

LANDSAT Follow-on Investigation 28 600

INVESTIGATION OF LANDSAT IMAGERY ON CORRELATIONS BETWEEN
ORE DEPOSITS AND MAJOR SHIELD STRUCTURES IN FINLAND

"Made available under NASA sponsorship
in the interest of early and wide dis-
semination of Earth Resources Survey
Program information and without liability
for any use made thereof."

by Viljo Kuosmanen

7.8 - 100.1.2
CR-155216

for P.I. Heikki V. Tuominen
Department of Geology
University of Helsinki
Snellmaninkatu 5
SF-00170 Helsinki 17
Finland

September 1977

Final Report

(E78-10012) INVESTIGATION OF LANDSAT IMAGERY ON CORRELATIONS BETWEEN ORE DEPOSITS AND MAJOR SHIELD STRUCTURES IN FINLAND Final Report, Jua. 1975 - Sep. 1977 (Helsinki Univ.) 59 p HC A04/MF A01	N78-10537 Unclas G3/43 00012
--	--

Ministry of Commerce and
Industry,
Finland

Aleksanterinkatu 10
SF-00170 Helsinki 17
Finland

Goddard Space Flight Center
Greenbelt, Maryland 20771



UNIVERSITY OF HELSINKI
DEPARTMENT OF GEOLOGY AND MINERALOGY
SNELLMANINKATU 5
PL 115, SF-00171 HELSINKI 17, FINLAND

Our ref.: HVT/th

25th Oct. 1977

NASA Scientific and
Technical Information Service
6571 Elkridge Landing Road
Linthicum, Maryland 21090
U.S.A.

Dear Sirs,

Enclosed please find a copy of the Final Report for
LANDSAT follow-on investigation '28 600 titled

"Investigation of LANDSAT Imagery on Correlations
between Ore Deposits and Major Shield Structures in
Finland".

Yours sincerely

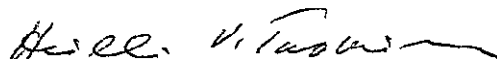

Heikki V. Tuominen
Principal Investigator

Encl. 1

LANDSAT Follow-on Investigation 28 600

INVESTIGATION OF LANDSAT IMAGERY ON CORRELATIONS BETWEEN
ORE DEPOSITS AND MAJOR SHIELD STRUCTURES IN FINLAND

by Viljo Kuosmanen

for P.I. Heikki V. Tuominen
Department of Geology
University of Helsinki
Snellmaninkatu 5
SF-00170 Helsinki 17
Finland

September 1977

Final Report

Original photography may be purchased from:
EROS Data Center

Sioux Falls, SD

Ministry of Commerce and
Industry,
Finland

Aleksanterinkatu 10
SF-00170 Helsinki 17
Finland

Goddard Space Flight Center
Greenbelt, Maryland 20771

**ORIGINAL CONTAINS
COLOR ILLUSTRATIONS**

1. TITLE PAGE

1. 28600	2. Final Report	3. Recipient's Catalog. No.
4. Title Investigation of LANDSAT Imagery on Correlations between Ore Deposits and Major Shield Structures in Finland		5. Report Date September 30, 1977
		6. Period Covered June 1975 - Sept. 1977
7. Principal Investigator Dr. Heikki V. Tuominen <i>etc</i>		8. No. of pages 53
9. Name and Address of Principal Investigator's Organization Dept. of Geology, Univ. of Helsinki Snellmaninkatu 5 SF-00170 Helsinki 17, Finland		10. Principal Investigator's Report No.
		11. GSEC Technical Monitor
12. Sponsoring Agency, Name and Address Ore-geological Commission of Northern Finland, Ministry of Commerce and Industry, Aleksanterinkatu 10 SF-00170 Helsinki 17, Finland		13. Key Words (Selected by P.I.) Landsat, Imagery, Lineament, Frequency, Ore deposit, Geology, Finland
14. Supplementary Notes Report Prepared by Viljo Kuosmanen, M.Sc. Department of Geology, Univ. of Helsinki Snellmaninkatu 5 SF-00170 Helsinki 17, Finland		
15. Abstract Several regional lineaments appear to correlate with the distribution of ore deposits and showings. Combined study of Landsat summer and winter mosaics and color composites of geological, geomorphological and geophysical maps makes the correlation more perceptible. The revealed pattern of significant lineaments in northern Finland is fairly regular. The most significant lineaments seen in Landsat mosaics are not detectable in single images. Ore exploration based on this network of lineaments is recommended.		

2 CONTENTS

	Page
1 Title page	1
2 Contents	2
3 List of illustrations, tables and plates	3
4 Preface	7
5 Introduction	9
6 Techniques	11
6.1 General	11
6.2 Data	11
6.2.1 LANDSAT imagery	11
6.2.2 Background data	17
6.3 Methods	17
6.3.1 Analog methods	17
6.3.2 Digital methods	20
7 Results	22
7.1 Component data	22
7.1.1 Lithologic units	22
7.1.2 Gravity map	26
7.1.3 Regional Landsat lineaments and other indications of geologic structures	28
7.2 Combined data	28
7.2.1 General	28
7.2.2 Enhanced and combined maps and pictures	30
7.2.3 Significant fracture zones	39
8 Conclusions	43
9 Publications, reports, etc.	45
10 Recommendations	45
11 References	47
12 Appendix	53

3 LIST OF ILLUSTRATIONS, TABLES AND PLATES

<u>Figures</u>		<u>Page</u>
Fig. 1.	Test sites of programs Nos. SR-580-3 and 28600.	12
Fig. 2.	Coverage of LANDSAT images used for the summer mosaic (identification in Table 1).	13
Fig. 3.	Coverage of LANDSAT images used for the winter mosaic (identification in Table 2).	15
Fig. 4.	Analog treatment of pictorial data to facilitate comparison of different maps and pictures.	17
Fig. 5.	Flow chart of the Fourier and <u>gradient</u> analysis.	21
Fig. 6.	Flow chart of the analog-digital rose-map analysis.	21
Fig. 7.	The two test sites of densitometric study of field objects. Corresponding Landsat images are indicated.	22
Fig. 8.	(a) Rose diagram map of the bog-and-water map of Finland.	25
	(b) Clusters of 'homogeneous' trend patterns of bogs and water courses. Mean rose diagrams on the left.	25

- Fig. 9. Wiener spectra (rotated 90° counter-clockwise), of Bouguer anomalies of northern (a) and central (b) Finland. 27
- Fig. 10. A color combination of the height contour map (red), edge enhanced aeromagnetic map (green) and bog-and-water map (blue) of northern Finland. The pink dots mark the locations of ore deposits and ore indications. The lineaments of this picture are sketched on the transparent overlay, Plate I (in the folder). 32
- Fig. 11. A color combination of the height contour map (red), edge enhanced aeromagnetic map (green) and bog-and-water map (blue) of southern Finland. 33
- Fig. 12. Landsat summer image mosaic over Finland. 34
- Fig. 13. Landsat winter image mosaic over Finland. 35
- Fig. 14. Location of the 'Main Sulfide Ore Belt'. The heavy line indicates the coverage of the optically filtered Bouguer anomaly map, Fig. 15. 37
- Fig. 15. Optically filtered Bouguer anomaly map. The arrows indicate some long lineaments extending across the 'Main Sulfide Ore Belt.' Location of the area is indicated in Fig. 14. 38

<u>Tables</u>	<u>Page</u>	
Table 1.	List of LANDSAT images accepted for summer mosaic (Coverage indicated in Fig. 2).	14
Table 2.	List of LANDSAT images accepted for winter mosaic (Coverage indicated in Fig. 3).	16
Table 3.	Characteristics of the map collection used. The maps and images indicated by 'x' are mosaics. Images indicated by '+' have been used as single pictures and mosaics.	18
Table 4.	The maps and their derivatives which were color-combined. The most informative combination is marked by X.	31
Table 5.	Trends, spacings and base-metal occurrences of the most significant fracture sets.	42

Plates (in the folder)

Plate I.	Relevant structures for ore prospecting in northern Finland (observed in program No. 28600).
Plate II.	Main block boundaries of northern Finland (observed in program No. SR-580-3).

Plate III Prominent lineaments in Landsat test
 areas of Finland.

Plate IV Ore deposits and showings.

Plate V , a) Schematic representation of fractures
 from Plate I. b) Theoretically estimated
 Wiener-spectrum of drawing (a).

4. PREFACE

The geologic Landsat follow-on program, Number 28600, discussed in the present report was a direct continuation of the earlier Landsat-1 program, Number SR-580-3. Both investigations were carried out in the Department of Geology of the University of Helsinki under the direction of P.I. Heikki V. Tuominen. The follow-on investigation was made during the years 1975-1977.

The financial sponsor of the work was the Ore-Geological Commission of Northern Finland appointed by the Ministry of Commerce and Industry. The Geological Survey of Finland, the exploration departments of the mining companies Outokumpu Oy and Rautaruukki Oy and the Geophysics Department of Oulu University assisted in the investigation.

Besides Viljo Kuosmanen, the project leader, the program staff consisted of Juha Karhu, Aimo Kuivamäki, Kimmo Niskanen, Kaj Österlund, Jorma Räsänen and Tapio Ruotoistenmäki. Many students as well as the personnel of the Department of Geology also took part in the work.

Jouko Talvitie acted as the co-investigator of the program. Discussions with Jussi Aarnisalo, the co-investigator of our Landsat-1 program, have proved useful to the author.

Aimo Mikkola kindly contributed his personal collection of ore data to our investigation. Simo Poso made available his densitometric measurements performed on common test sites in northern Finland. The Geodetic Institute of Finland delivered data on Bouguer anomalies in the test areas. The Ore Data File Project of Northern Finland gave additional information about base metal occurrences in northern Finland. The Photogrammetric Division of the Finnish National Board of Survey compiled the controlled LANDSAT mosaics over Finland. The Photographic Service Center of Helsinki University gave assistance in developing apodized filters for coherent optical data processing and in reproducing various photographs. The Computing Centre of Helsinki University gave advice on many statistical problems, and sponsored the ADP services.

The criticism by NASA on the draft of this report has been taken into account. We are also grateful to Jussi Aarnisalo, Gabor Gaál, Caj Kortman, Aimo Mikkola, Heikki Paarma and Jouko Talvitie for critical reading of the draft.

A sea-ice investigation in the Gulf of Bothnia was later added as a secondary discipline to the Landsat program No 28600. The results of this investigation are given briefly in the Appendix of the report.

5. INTRODUCTION

In the Baltic Shield, several types of important ore deposits and indications of ore appear to be distributed along or near major fracture zones. Owing to the glacial drift cover, shallow topography and great width of the zones (up to 50 km), these zones are not easily detected in the field by either ground or airborne methods. The purpose of the investigation was to examine the expected advantages of LANDSAT imagery in exploring these structures. The test areas for the study are located in the central part of the Shield.

Controversial opinions concerning correlations between lineaments and distribution of ore deposits have been expressed in recent years. For example, the papers of Kutina (1969, 1971), Heyl (1972) and Baker (1975) suggest the concept of a positive correlation, while Gilluly (1976) and Lattman (1976) come to the opposite conclusion. In the central part of the Baltic Shield, a positive correlation between the Landsat lineaments and distribution of ore mineralizations has been suggested by Tuominen and Aarnisalo (1976) as a result of their Landsat-1 investigation.

In Finland, the study of major geological structures through Landsat imagery has been carried out in two phases. In the Landsat-1 program (SR-580-3, Tuominen and Aarnisalo 1976),

the investigation ran from detailed information, such as aerial photographs, to Landsat imagery and other more regional data. In the Landsat follow-on program No. 28600, discussed in the present paper, the opposite procedure was followed. For observing the Landsat linears, and testing their significance, the comparative investigation of ground data was started from small-scale geophysical, geological and geomorphological maps. In both programs, primary attention was paid to northern Finland. In the follow-on phase, the so-called Main Sulfide Ore Belt (Kahma 1973), extending from Lake Ladoga northwest to the Gulf of Bothnia, was tentatively investigated.

6 TECHNIQUES

6.1 General

Satellite pictures reveal only the most superficial features. To extract from areas remodelled by glacial processes those features that are related to the bedrock geology, additional information of deeper extent is necessary. This means that in these conditions LANDSAT imagery provides only an extra "channel" to complement the map collection useful to a bedrock geologist. Therefore, to test the utility of the LANDSAT data, they were here treated as one component in a 'multichannel' system of numerous other maps.

6.2 Data

6.2.1 LANDSAT imagery

Landsat MSS images of Finland have been received since 1972. The test sites of the geological programs Nos. SR-580-03 and 28600 are indicated in Fig. 1. Figs. 2 and 3 show the coverage of sufficiently cloudless scenes. They are listed in Tables 1 and 2 respectively. The band-7 images of these scenes have been compiled to form mosaics of summer and winter pictures separately.

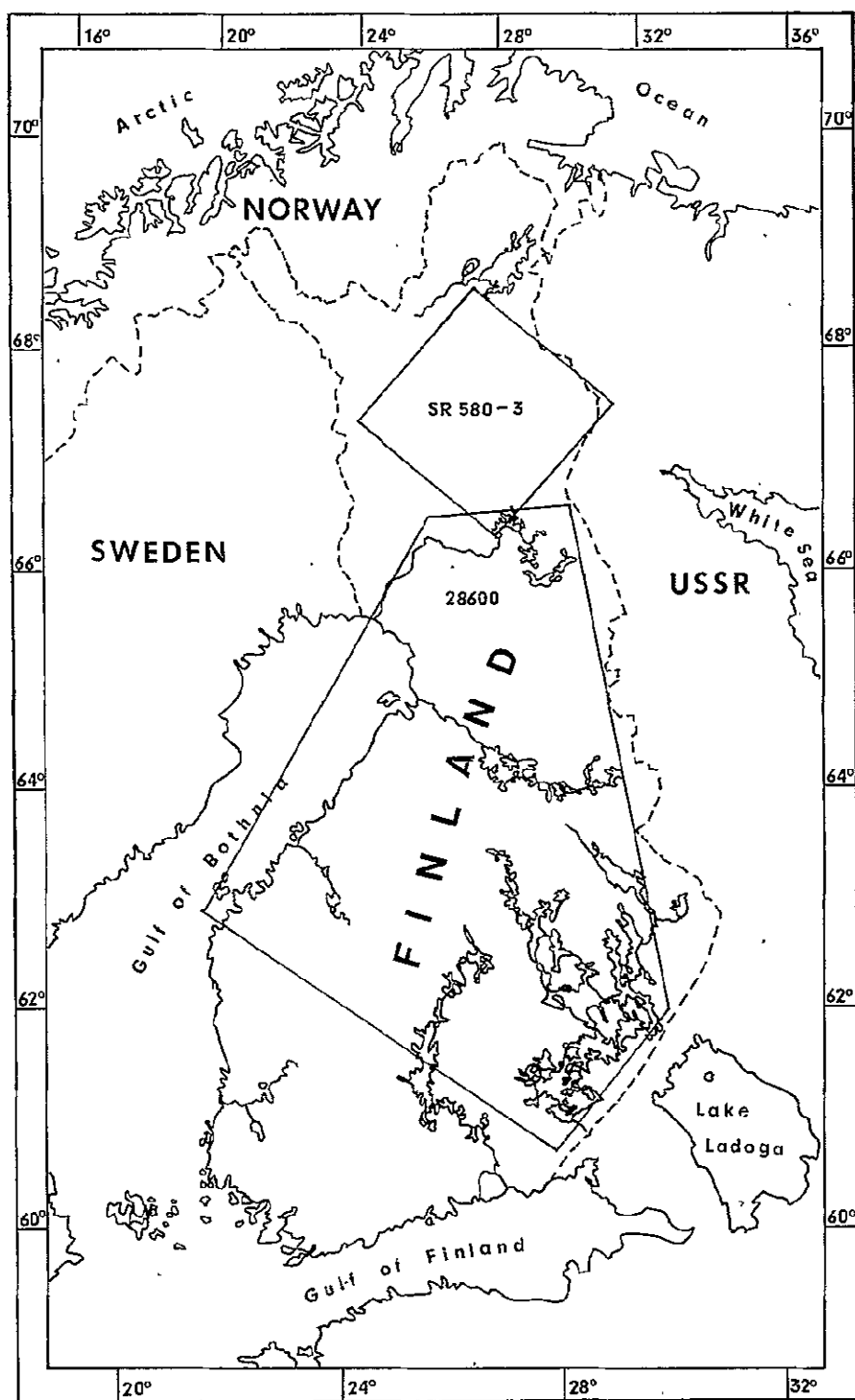

Fig. 1. Test sites of programs Nos. SR-580-3 and 28600.

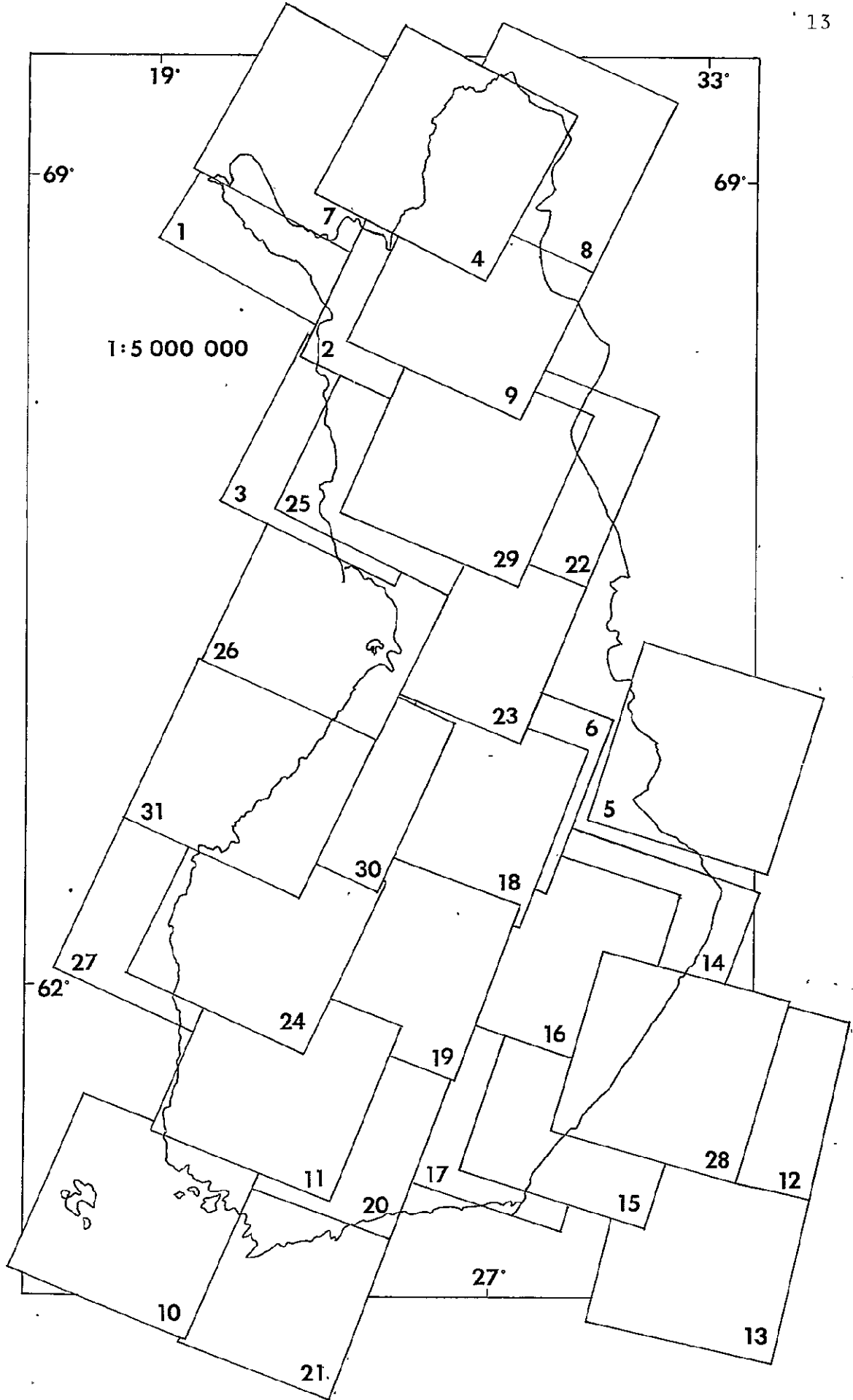

Fig. 2. Coverage of LANDSAT images used for the summer mosaic (identification in Table 1).

Number in Fig. 2	Image ID	Center	Date acquired
1	E-1006-09484	N68-54/E022-45	29 Jul -72
2	E-1039-09315	N68-05/E025-54	31 Aug -72
3	E-1039-09322	N66-46/E024-15	31 Aug -72
4	E-1040-09371	N69-25/E026-21	01 Sep -72
5	E-1050-08530	N64-08/E031-30	11 Sep -72
6	E-1053-09101	N64-05/E027-16	14 Sep -72
7	E-1330-09491	N69-32/E023-10	18 Jun -73
8	E-1362-09255	N69-24/E028-45	20 Jul -73
9	E-1362-09262	N68-06/E026-55	20 Jul -73
10	E-2051-09115	N60-05/E020-59	14 Mar -75
11	E-2086-09053	N61-22/E023-14	18 Apr -75
12	E-2098-08311	N61-13/E031-47	30 Apr -75
13	E-2098-08313	N59-50/E030-43	30 Apr -75
14	E-2136-08421	N62-28/E029-53	07 Jun -75
15	E-2136-08424	N61-06/E028-47	07 Jun -75
16	E-2137-08480	N62-28/E028-24	08 Jun -75
17	E-2137-08482	N61-05/E027-17	08 Jun -75
18	E-2139-08590	N63-45/E026-37	10 Jun -75
19	E-2139-08593	N62-25/E025-25	10 Jun -75
20	E-2139-08595	N61-02/E024-19	10 Jun -75
21	E-2139-09002	N59-39/E023-19	10 Jun -75
22	E-2158-09040	N66-40/E028-12	29 Jun -75
23	E-2158-09042	N65-20/E026-45	29 Jun -75
24	E-2159-09110	N62-38/E022-47	30 Jun -75
25	E-2160-09153	N66-40/E025-20	01 Jul -75
26	E-2160-09155	N65-20/E023-52	01 Jul -75
27	E-2160-09164	N62-38/E021-19	01 Jul -75
28	E-2171-08365	N61-26/E030-22	12 Jul -75
29	E-2537-09023	N66-41/E026-44	12 Jul -76
30	E-2537-09032	N64-00/E023-57	12 Jul -76
31	E-2538-09090	N63-59/E022-27	13 Jul -76

Table 1. List of LANDSAT images accepted for the summer mosaic
(Coverage indicated in Fig. 2)

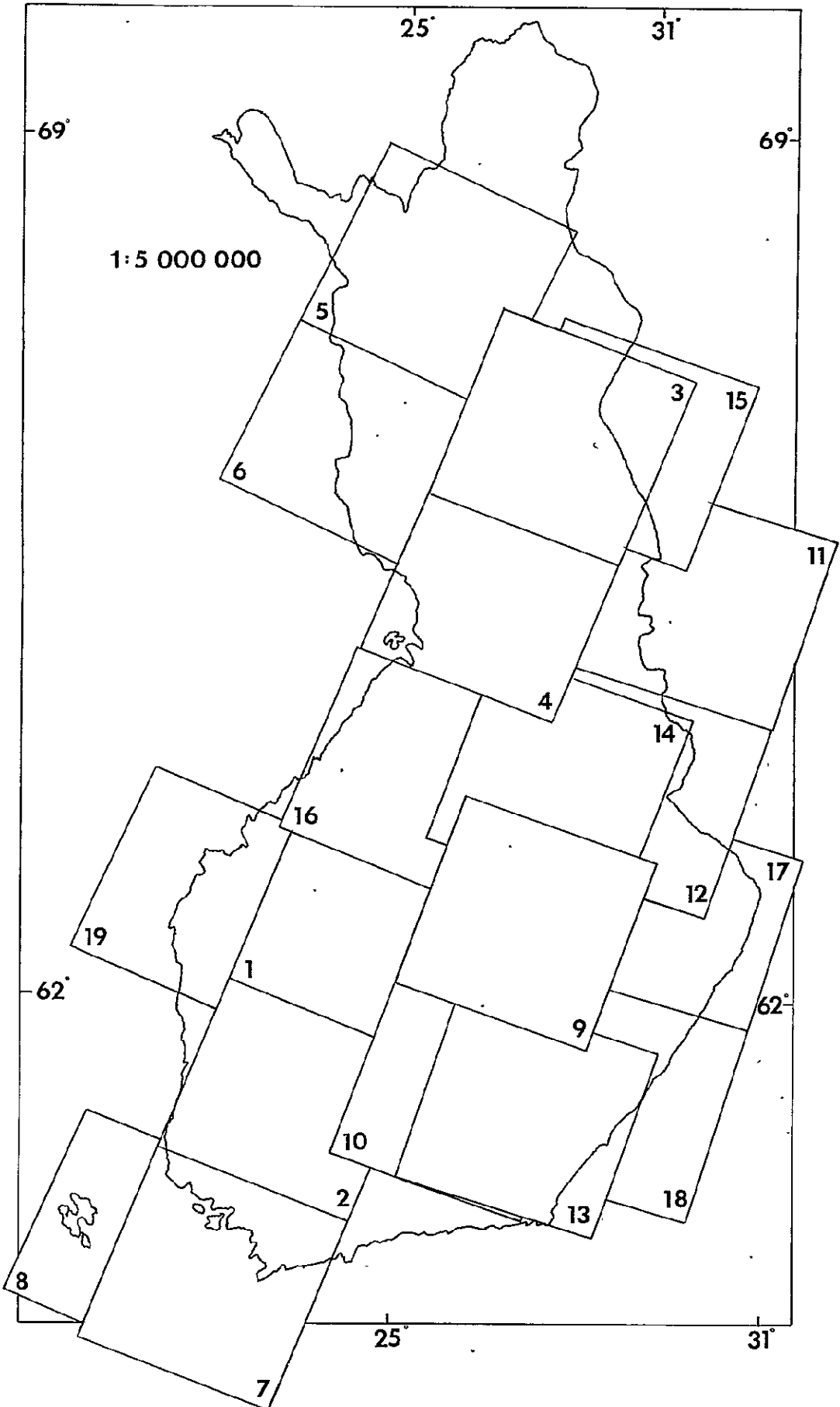

Fig. 3. Coverage of LANDSAT images used for the winter , mosaic (identification in Table 2).

Number in Fig. 3	Image ID	Center	Date acquired
1	E-1216-09172-7	N62-45/E024-26	24 Feb -73
2	E-1216-09174-7	N61-23/E023-17	24 Feb -73
3	E-1234-09161-7	N66-43/E028-3	14 Mar -73
4	E-1234-09164-7	N65-19/E026-51	14 Mar -73
5	E-1237-09330-7	N68-03/E025-40	17 Mar -73
6	E-1237-09333-7	N66-44/E024-02	17 Mar -73
7	E-2050-09061-7	N60-03/E022-27	13 Mar -75
8	E-2051-09115-7	N60-05/E020-59	14 Mar -75
9	E-2084-08534-7	N62-47/E027-18	16 Apr -75
10	E-2084-08541-7	N61-25/E026-69	16 Apr -75
11	E-2407-08434-7	N65-17/E039-56	4 Mar -76
12	E-2407-08440-7	N63-56/E029-37	4 Mar -76
13	E-2407-08445-7	N61-13/E027-17	4 Mar -76
14	E-2408-08494-7	N63-54/E028-03	5 Mar -76
15	E-2409-08544-7	N66-38/E029-33	6 Mar -76
16	E-2410-09011-7	N63-55/E025-22	7 Mar -76
17	E-2424-08381-7	N62-42/E029-57	21 Mar -76
18	E-2424-08384-7	N61-19/E028-50	21 Mar -76
19	E-2448-09115-7	N62-54/E021-35	14 Apr -76

Table 2. List of LANDSAT images accepted for the winter mosaic (coverage indicated in Fig. 3).

6.2.2 Background data

Numerous geological, geophysical and geomorphological maps were used in testing the geologic significance of the various features appearing in the LANDSAT imagery. Table 3 summarizes the characteristics of the data utilized in the present study. As the size range of the features recognizable on the satellite photographs is large, the background map information was studied on several scales.

6.3 Methods

6.3.1 Analog methods

The data collection was composed of color, halftone and binary maps and pictures. Nearly the same analog methods were applied to all of them. The scheme of the procedure is given in Fig. 4.

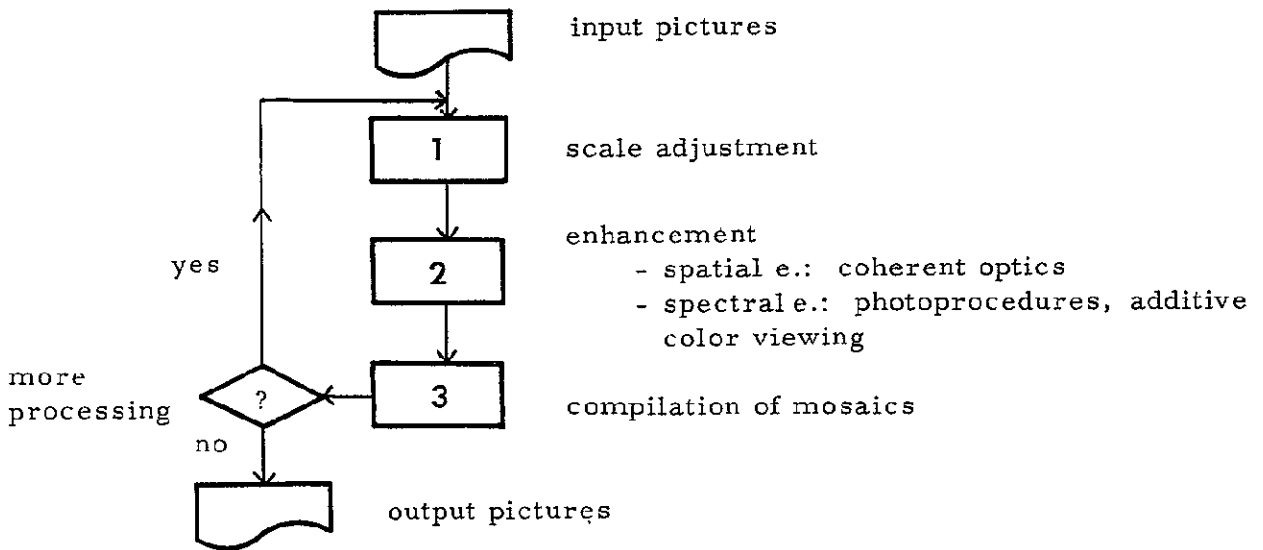

Fig. 4. Analog treatment of pictorial data to facilitate comparison of different maps and pictures.

Map/image	Scale	Unit size
1 Aeromagnetic map	1: 400 000 ^x	30 x 40 km ²
2 "	1:1 000 000 ^x	"
3 "	1:2 000 000 ^x	"
4 "	1:4 000 000 ^x	"
5 Bouguer anom. map	1: 400 000	all Finland
6 "	1:1 000 000	"
7 "	1:2 000 000	"
8 "	1:4 000 000	"
9 Height contour map	1: 400 000	120 x 160 km ²
10 "	1:1 000 000	all Finland
11 "	1:2 000 000	"
12 "	1:4 000 000	"
13 Bog-and-water map	1:1 000 000 ^x	"
14 "	1:2 000 000 ^x	"
15 "	1:4 000 000 ^x	"
16 Geologic bedrock map	1: 100 000	30 x 40 km ²
17 "	1: 400 000	120 x 160 km ²
18 "	1:1 000 000	all Finland.
19 "	1:2 000 000	"
20 Landsat images	1: 400 000	185 x 185 km ²
21 "	1: 500 000 ⁺	"
22 "	1:1 000 000 ⁺	"
23 "	1:2 000 000 ^x	"
24 "	1:4 000 000 ^x	"
25 "	1:5 000 000 ^x	"

Table 3. Characteristics of the map collection used. The maps and images indicated by 'x' are mosaics. Images indicated by '+' have been used as single pictures and mosaics.

a) Scale adjustment was made by reproducing films or plates of a suitable format (Fig. 4). Problems were encountered in making small ($\phi = 10-60$ mm) high-resolution input pictures of different sources on equal scales for coherent optical analysis and additive color viewing.

b) The following optical enhancement and copy techniques were used (Fig. 4):

- B & W enlarging, contact copying and reprography
- Additive color viewing (equipment: A/S Sigurd Sörum, Norway).
- Optical Fourier-transform analysis (equipment: optical filter IFP type F0-100).
- Enhancement of high-frequency information by photographic masking and coherent optical high-pass filtering.
- Enhancement of low-frequency information by photographic degrading and coherent optical low-pass filtering.
- Photographic B & W combinations of high contrast negatives and/or positives of different maps.

c) Separate LANDSAT image mosaics of band 7 were made for summer and winter:

- 1:500 000 and 1:1 000 000 uncontrolled mosaics were made by the author.
- 1:1 000 000 controlled and tone-corrected mosaics were compiled by the Finnish National Board Survey, Photogrammetric division.

d) The mosaics were reduced in scale, enhanced and combined with other data as indicated by the feedback-loop in Fig. 4.

6.3.2 Digital methods

The following background data were analyzed by ADP (UNIVAC-1108):

To distinguish between high- and low-frequency structural features, Fourier analysis and gradient enhancement were applied to the Bouguer anomaly map of northern Finland . (Kuosmanen 1975).

To test whether certain regional differences in the fracture patterns suggested by the Landsat-1 investigation (see p. 25) can be verified by other data, the trends of bogs and water courses were analyzed approximately in the way proposed by Golbraikh et al. (1966, 1968). It is a simplified method for recognition of spatial patterns: A hexagonal grid was used to take samples of circular units (480 pieces, $\phi = 30$ km) from the bog and water map. These samples were photographed on plates, and the strike frequencies per degree were extracted by coherent optics.

The results were digitized (Bendix/Datagrid Digitizer), normalized and drawn to a rose diagram map (Fig. 8a). A residual rose diagram was calculated for each sample by subtracting 31-term moving averages. The residuals were simplified, strike frequencies per 9 degrees were formed and unsupervisedly clustered in four groups to find areas of 'homogeneous' trend patterns (Fig. 8b).

The flow charts of the ADP procedures are shown in figures 5 and 6.

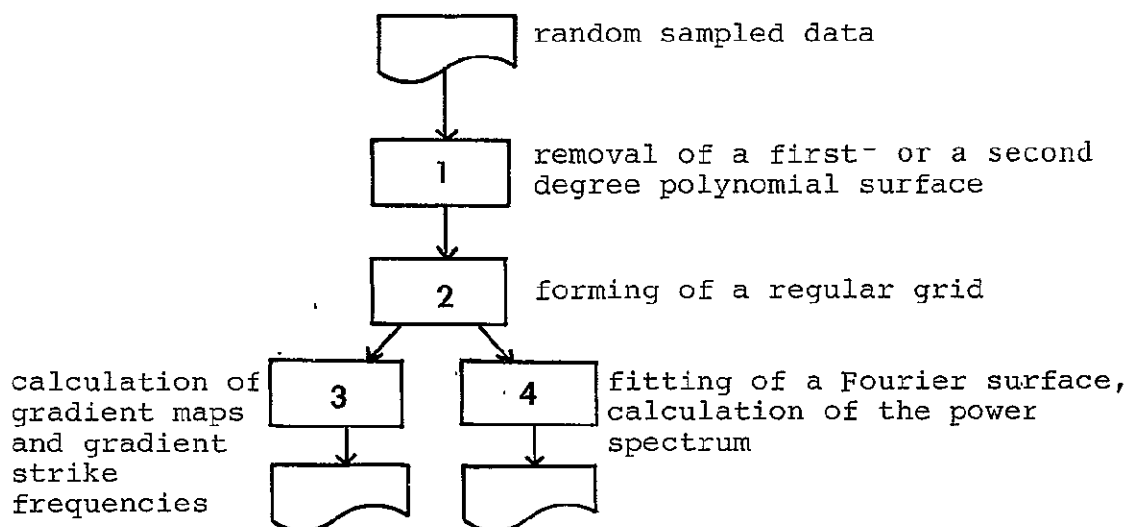

Fig: 5. Flow chart of the Fourier and gradient analysis.

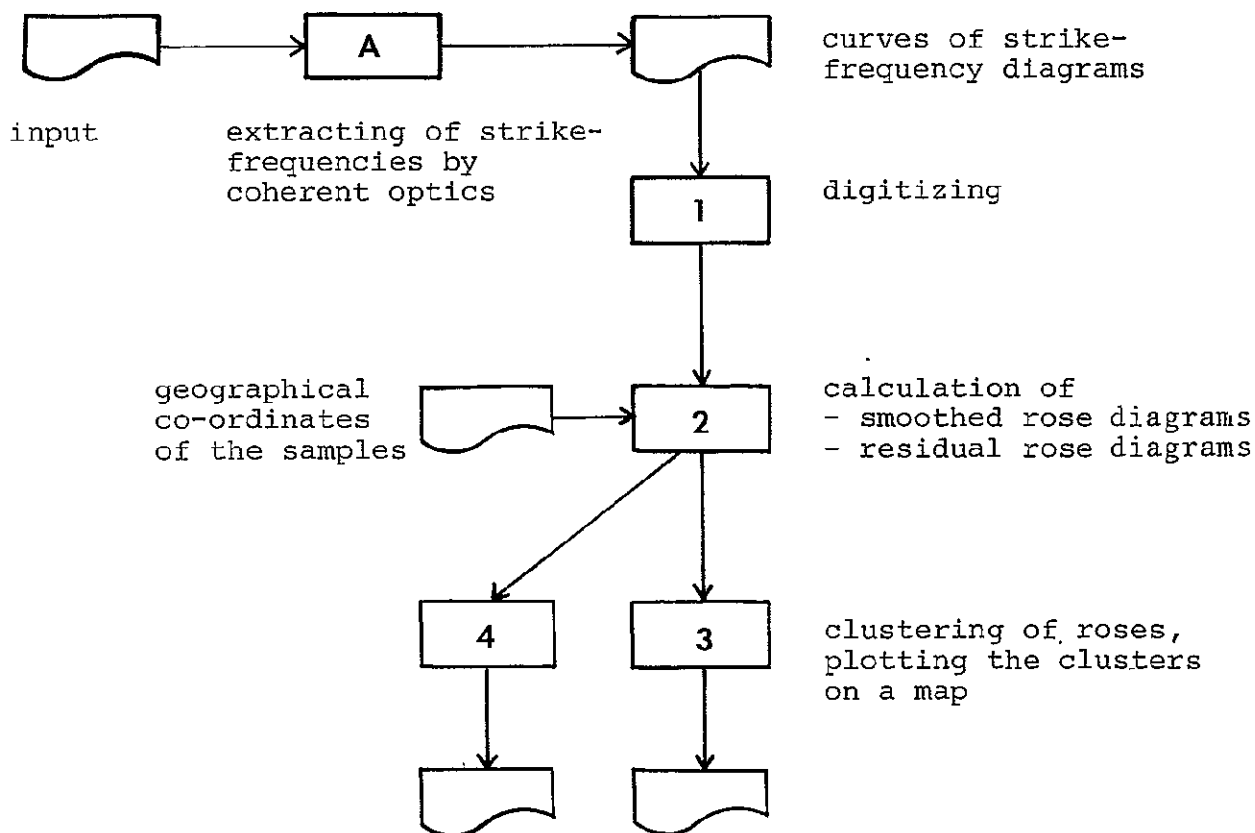

Fig. 6. Flow chart of the analog-digital rose-map analysis.

7 RESULTS

7.1 Component data

7.1.1 Graytones and textures as indicators of lithologic/ structural units

Kuivamäki (1977) analyzed the relationships between Landsat graytones and field objects. The graytones of two test sites $96 \times 16 \text{ km}^2$ each, Fig. 7., in northern Finland were digitized densitometrically. Field data concerning rock and soil types, vegetation and topographic features were recorded on 500 sub-areas ($100 \times 100 \text{ m}^2$) of each test site.

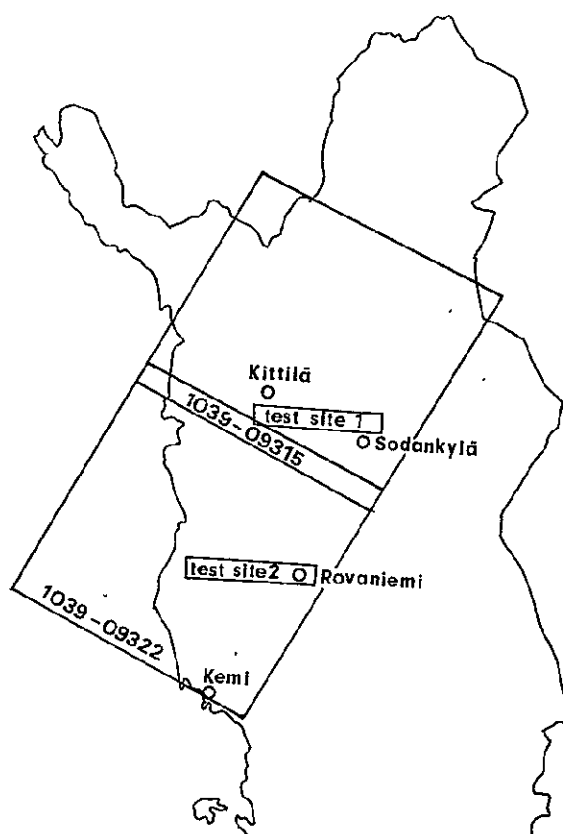

Fig. 7. The two test sites of densitometric study of field objects. Corresponding Landsat images are indicated.

In these test sites, the vegetation, soil cover and their humidity were found to control nearly all the spectral variation in the Landsat data. Because of climatic differences (differences in latitude, height, etc.) and density level gradients, no soil type has a uniform graytone on any band except locally; the graytones of these two test sites are different, but they are uniform within each single site.

The following types were interpreted with high confidence (indicated in percentages) by ADP:

- Well sorted dry gravel and sand. Vegetation: pine and reindeer lichen (83%).
- Fairly dry till with abundant ground vegetation and mixed forest (67%).
- Fairly dry peat covered by grass and hay (93%).
- Bare outcrops and blockfields (83%).

The densities of the Landsat images respond to changes in the quantity of trees of three major types in the following way:

- When the quantity of pine increases, the density of band 7 increases.
- When the quantity of birch increases, the density of band 7 decreases.
- When the quantity of spruce increases, the density of band 5 increases.

For the classification, bands 5 and 7 were generally the most useful except in the case of silt and peat, for which bands 4 and 6 were the best.

As regards the spectral data obtained from the drift-covered subareas, no influence of the bedrock type on the Landsat graytones was detectable. It is well known, however, that vegetational characteristics frequently vary with the type and relief configuration of the underlying bedrock. The corresponding differences in vegetation, which can hardly be recorded by ordinary mapping, are in many cases revealed by spatial graytone differences in Landsat imagery. For this reason, the foregoing results can be indirectly used in the interpretation of Landsat imagery for tectonic features.

Major lithologic units show up in many cases through specific image textures (Tuominen and Kuosmanen 1976). The textures were tentatively classified into eight groups: angulate, folded angulate, parallel, striated, radial, rectangular, annular and kettle holes (Parvis 1950). Best discernible in this way are areas of granitoids and schist belts.

According to the Landsat-1 investigation (Tuominen and Aarnisalo 1976 p. 55 and 83), the fracture trends and patterns of the main tectonic/lithologic units and blocks of northern Finland are different. The trend-pattern clusters of the bog-and-water map (p. 25 and Fig. 8.) are in a general agreement with this

ORIGINAL PAGE IS
OF POOR QUALITY

result. The mean rose diagrams (on the left of Fig. 8b) characteristic of the different clusters can be examined only qualitatively, i.e., the azimuth of a peak is more significant than its amplitude. The highest maxima generally represent those fractures which have been parallel or nearly parallel to the glacial flow.

It seem possible that these local (sample diameter ≈ 30 km) trend patterns are related to more regional fractures.

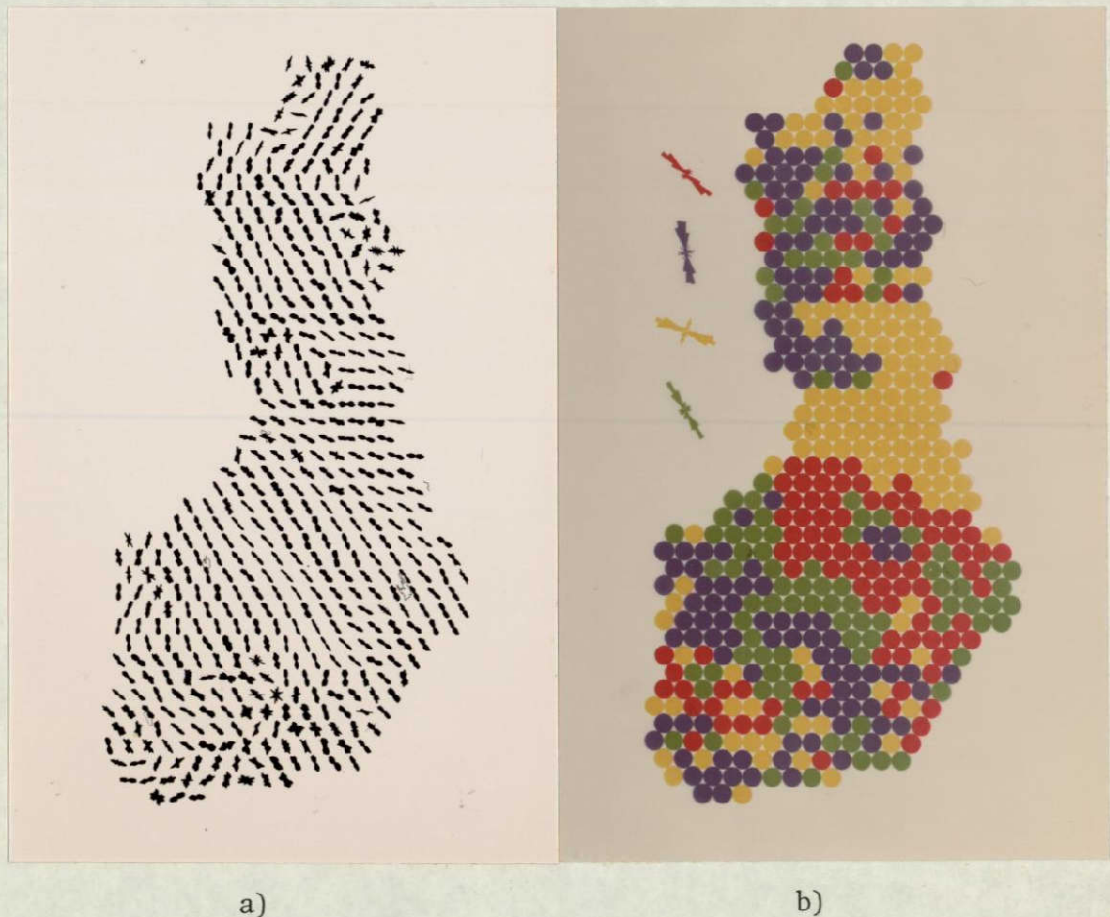

Fig. 8. (a) Rose diagram map of the bog-and-water courses of Finland.

(b) Clusters of 'homogeneous' trend patterns of bogs and water courses. Mean rose diagrams on the left.

7.1.2 Gravity map

The map of Bouguer anomalies of central and northern Finland was digitally separated into components of different spatial frequencies (see chapter 6.3.2). Certain prominent lineaments shown by these transformation maps confirm a number of the Landsat lineaments to be geologically significant.

A Fourier transformation of the Bouguer anomalies was made and it is here shown in a Wiener-spectrum form (Fig. 9), which reveals 'hidden' characteristics of the map and verifies some tectonic features (p. 40). The Wiener spectra (Fig. 9) indicate the azimuth (ϕ), frequency (f) and amplitude (A) of sine and cosine waves of the Fourier surface fitted to the original Bouguer-reduced gravity observations (cf. Agterberg 1974, pp. 363-403).

For example, if the map were built up of units, each representing a width of 35 km, which in this situation corresponds to a frequency of 8.6, the variation from this source would, in the spectra, lie near the broken arc lines (Fig. 9). A relation of this type is discernible in the spectrum of northern Finland (Fig. 9a), but not so distinct in that of central Finland (Fig. 9b). The Wiener spectra also imply that in most cases regional and local anomalies have different strikes (Kuosmanen 1975).

We cannot say exactly what geological features have determined the locations of the maxima in the Wiener spectra. However, there is a conspicuous relationship between these maxima and major shield fractures, as will be shown later (p. 40).

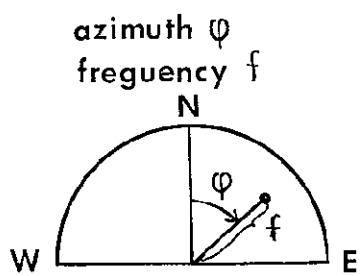
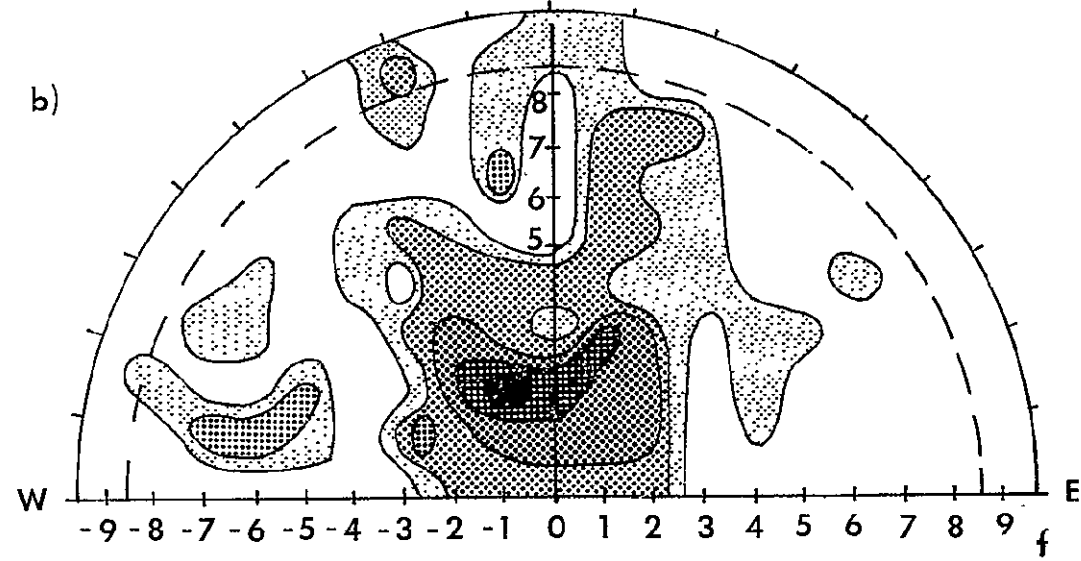
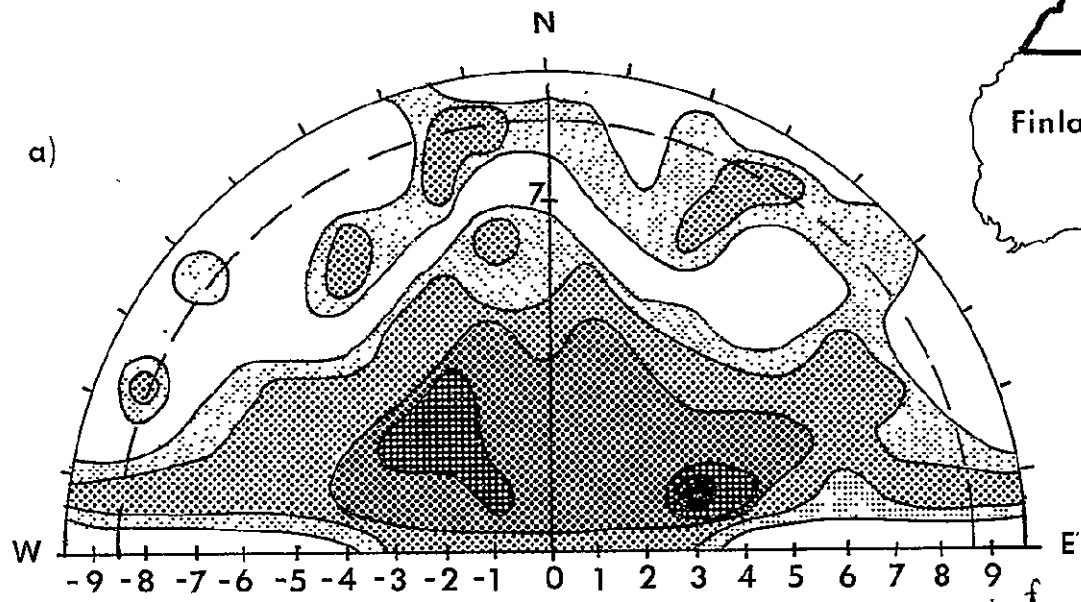
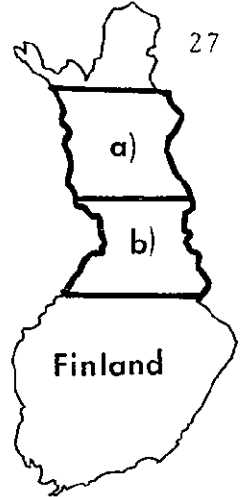

amplitude A (mgal)

	< 0.84		2.45 - 4.46
	0.84 - 1.10		4.46 - 6.32
	1.10 - 2.45		> 6.32

frequency 1 corresponds to a wavelength of 300 km
 " 5 " " " " " 60 "
 " 8.6 " " " " " 35 "

Fig. 9. Wiener spectra (rotated 90° counterclockwise) of Bouguer anomalies of northern (a) and middle (b) Finland.

7.1.3 Regional Landsat lineaments and other indications of geological structures

Uncontrolled (1:1 000 000) summer and winter mosaics were first used for finding regional lineaments (Tuominen and Aarnisalo 1976, plate III, Tuominen and Kuosmanen 1976, reports III and IV). After completion of the controlled mosaics, the lineaments found earlier were tested on them. This check-up caused only minor immediate changes. An additional significant set of lineaments, trending 15° - 27° , was observed only after having first been recognized from the color-composite map (Fig. 10).

The winter image mosaic was most useful in respect of regional lineaments. Owing to the low sun angle in the winter time, the lineaments approximately perpendicular to the azimuth of the sun (165°) appear enhanced.

Large folds, layering and circular units are also observable (Tuominen and Kuosmanen 1975, Räsänen 1975, Tuominen and Aarnisalo 1976).

7.2 Combined data

7.2.1 General

The Landsat data consist of a wide range of spatial frequencies. If the distribution of ore deposits is controlled by local structures, the images are useful because of relatively high

resolution. For the detection of more regional controlling structures, they provide a wide synoptic view.

Seismic investigations have revealed three (or four) layers of different density and variable thickness within the crust of the Baltic Shield (Kanestrøm 1971 p. 19, Penttilä 1972 p. 7), which may have reacted differently to deforming stresses. For this reason, it is possible that the strikes of some of the regional (deep) structures deviate from those of local (surface) structures. The deep structures, however, also have certain surficial traces (Tuominen et al. 1973 p. 206, Strömberg 1976 p. 234). Variation in those layers is seen as a variation in the respective spatial frequency components of geophysical and possibly also of geomorphological maps.

To understand the mutual relationships of deep-seated and surface structures, regional data were studied first and more local data were added stepwise to the investigation. It was found that the size and number of detected lineaments are highly dependent on the contents of spatial frequencies in the map information: Low frequencies give a few wide and long linears, while high frequencies give abundant tiny linears. After separation of the spatial frequency components of maps and pictures, the observation of a lineament becomes less controversial.

7.2.2 Enhanced and combined maps and pictures

The aim of the simultaneous viewing of maps and pictures is to perceive the indications of a certain geological structure from different data. The presence of such coinciding or complementing indications suggests that they come from existing geologic structures and are not accidental. Specifically, a linear visible in Landsat imagery only is probably not related to the bedrock geology.

To enhance the indications of structures of different magnitudes, most of the maps were first separated into components of different spatial frequencies. In Table 4, the low-frequency derivative is indicated above and the high-frequency derivative below each respective map. All possible combinations of every two or three maps (including the Landsat mosaics) were investigated by additive color viewing.

A combination (Fig. 10) of the height countour map, the edge-enhanced aeromagnetic map and the bog-and-water map (marked by X in Table 4) reveals a clear network of lineaments in northern Finland.

Nearly all the known ore deposits and ore indications seem to fit into this network (Fig. 10).

The lineaments of Fig. 10 are sketched in Plate I (in the folder) where those which are also seen in the Landsat mosaics are

1 Bouguer anomaly map		Fourier surface of 5x5 harmonic terms gradient map
2 Height contour map		degraded
3 Aeromagnetic map		degraded edge enhanced
4 Bog-and-water map		degraded edge enhanced
5 Bog map		
6 Landsat winter mosaic		
7 Landsat summer mosaic		

Explanations:



 = the map itself
 = a low-frequency derivative
of the map
 = a high-frequency derivative
of the map

Table 4. The maps and their derivatives which were color-combined. The most informative combination is marked by X.

ORIGINAL PAGE IS
OF POOR QUALITY

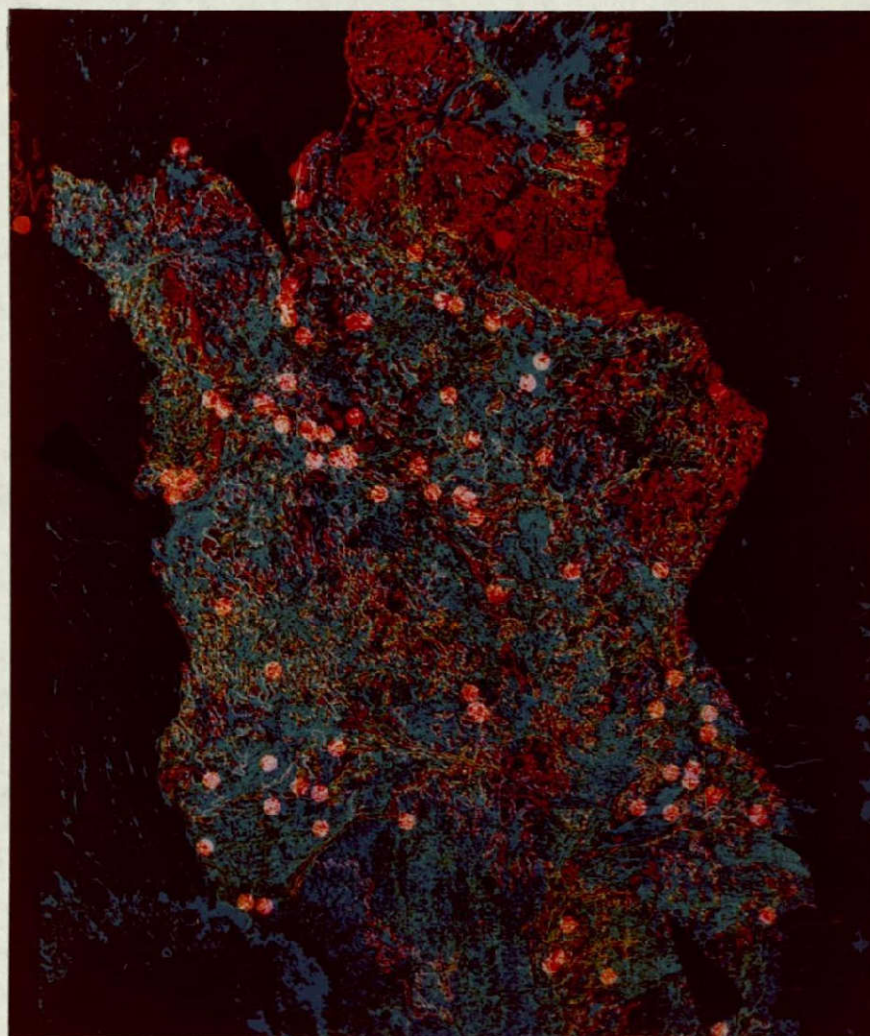

Fig. 10. A color combination of the height contour map (red), edge enhanced aeromagnetic map (green) and bog-and-water map (blue) of northern Finland. The pink dots mark the locations of ore deposits and ore indications. The lineaments of this picture are sketched on the transparent overlay, Plate I (in the folder).

ORIGINAL PAGE IS
OF POOR QUALITY

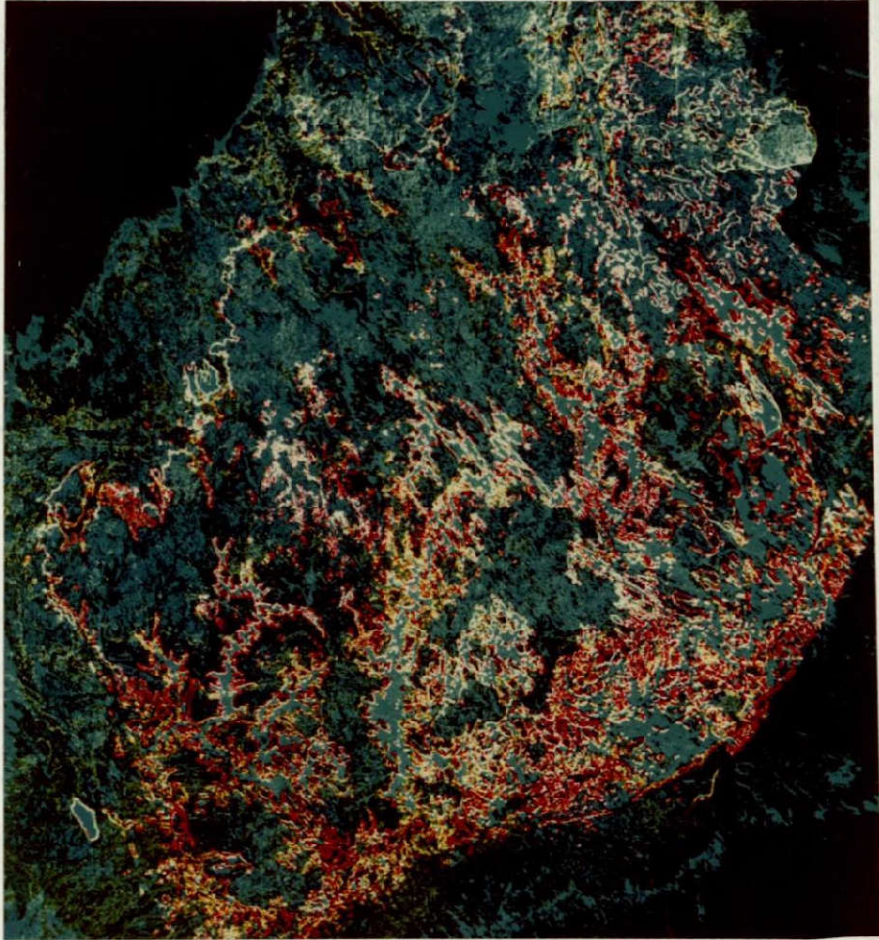
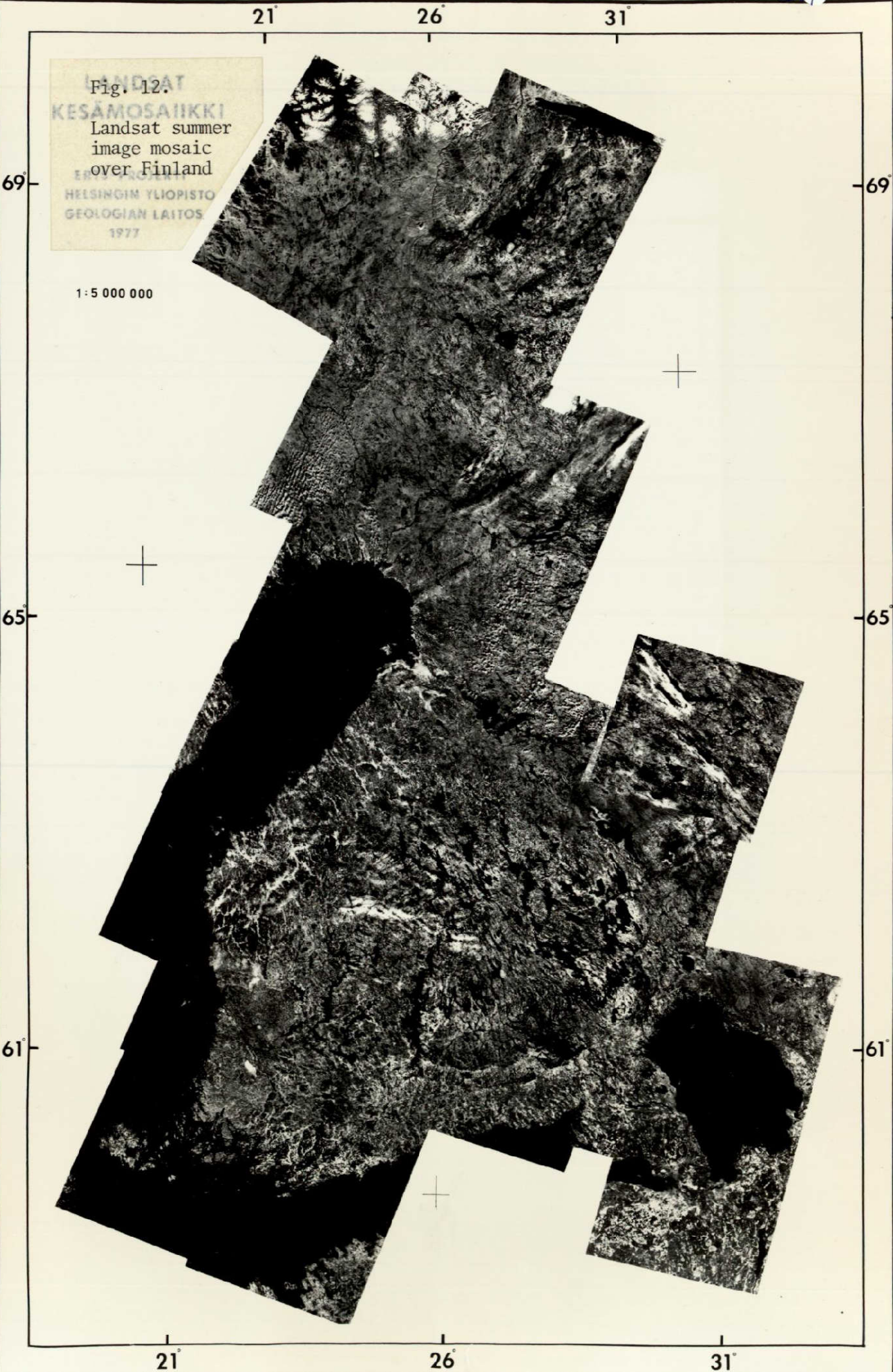
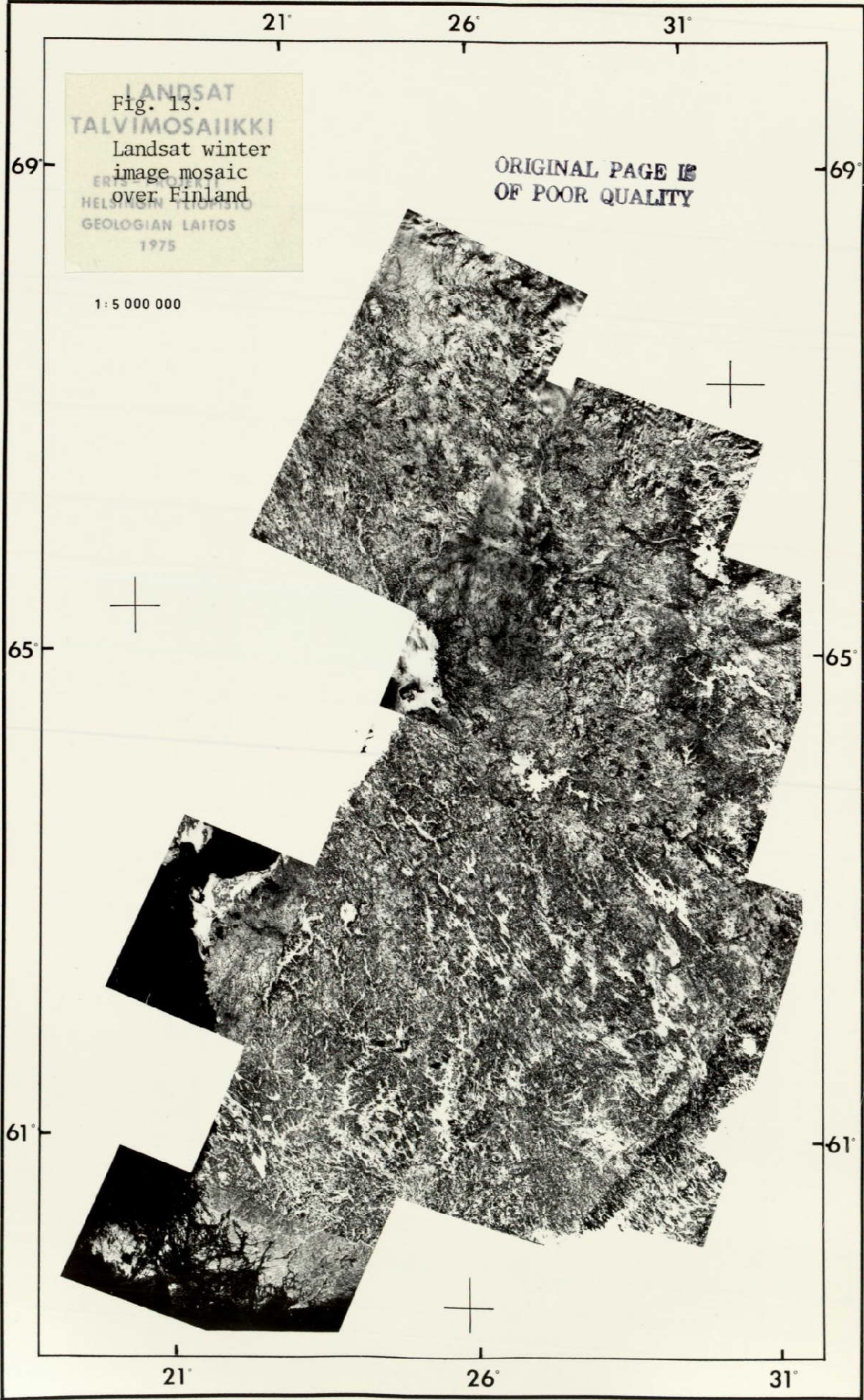

Fig. 11. A color combination of the height contour map (red), edge enhanced aeromagnetic map (green) and the bog-and-water map (blue) of southern Finland.

Fig. 12.
KESÄMOSAIIKKI
Landsat summer
image mosaic
over Finland
HELSINGIN YLIOPISTO
GEOLOGIAN LAITOS
1977

1:5 000 000





indicated by asterisks. Comparison with the Landsat mosaics (Figs. 12 and 13) is further illustrated by use of Plate III.

Some of the lineaments of northern Finland, in Fig. 10 and Plate I, have been described in previous literature (Härme 1961, Paarma 1963, Mikkola and Niini 1968, Tuominen et al. 1973, Vuorela 1973, Mikkola and Vuorela 1974, 1976, Kuosmanen 1975, Tuominen and Aarnisalo 1976, Aarnisalo 1977, Talvitie 1977). The azimuths of the subparallel lineaments are about 330° , 15° - 27° and 80° . Other directions, such as 290° , 300° - 315° and 45° - 55° , are also visible. The azimuths are expressed respective to the 26^{th} meridian East.

Plate II (in the folder) shows the main block boundaries interpreted during the Landsat-1 program (Tuominen and Aarnisalo 1976). Comparison of plates I and II shows the correlation between the results of both investigations, which, although partly based on the same material, were carried out independently and by a different technique.

The network obtained by a color combination of the respective maps and Landsat mosaics of southern Finland (Fig. 11 and Plate III below the broken line), is not as clear and systematic as that obtained for northern Finland. This applies, for instance, to the numerous lineaments of the so-called Main Sulfide Ore Belt (Fig. 14). This Precambrian 'geofracture' is nearly 100 km wide and extends from Lake Ladoga northwest across the Gulf of

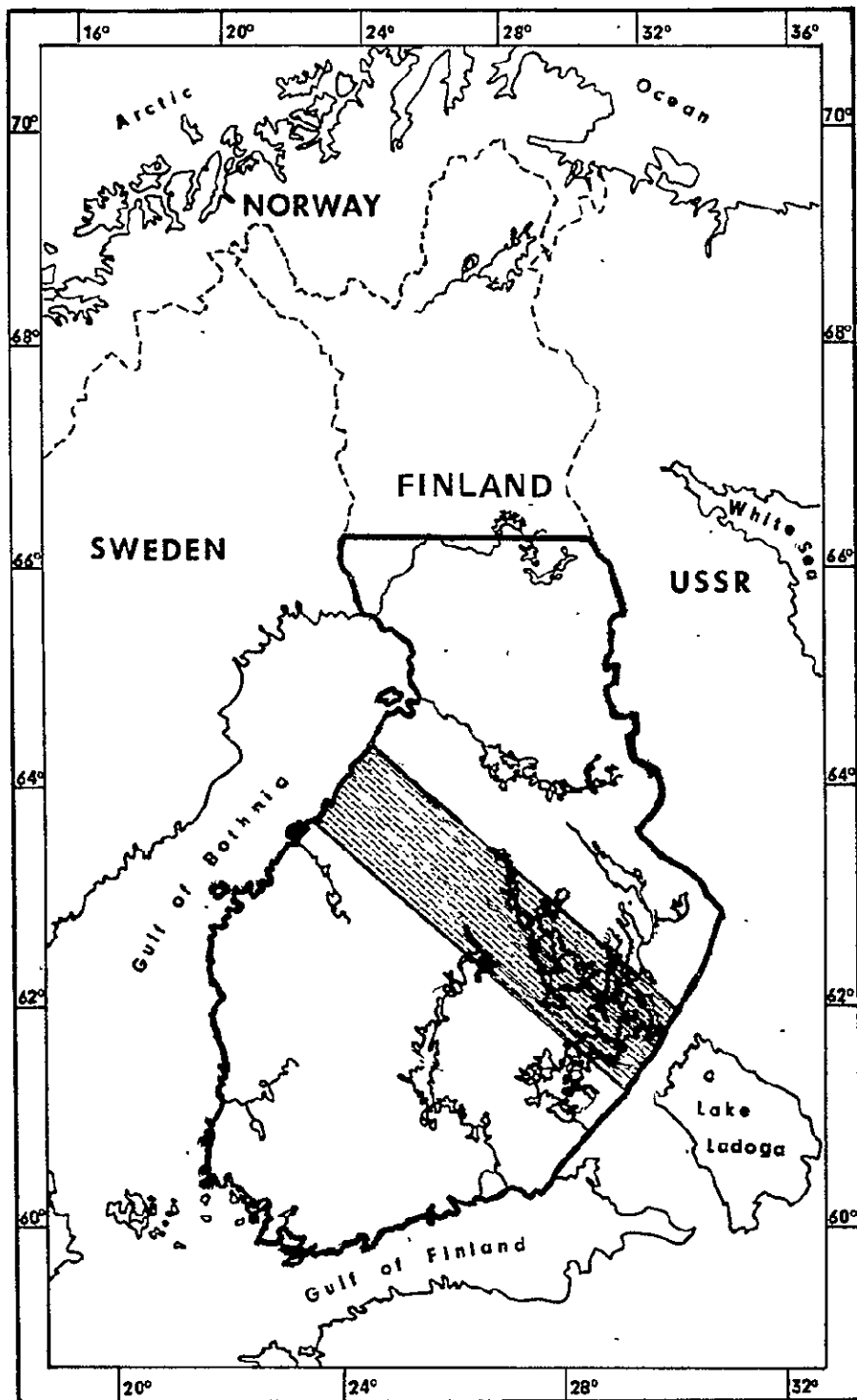

Fig. 14. Location of the Main Sulfide Ore Belt. The heavy line indicates the coverage of the optically filtered Bouguer anomaly map, Fig. 15.

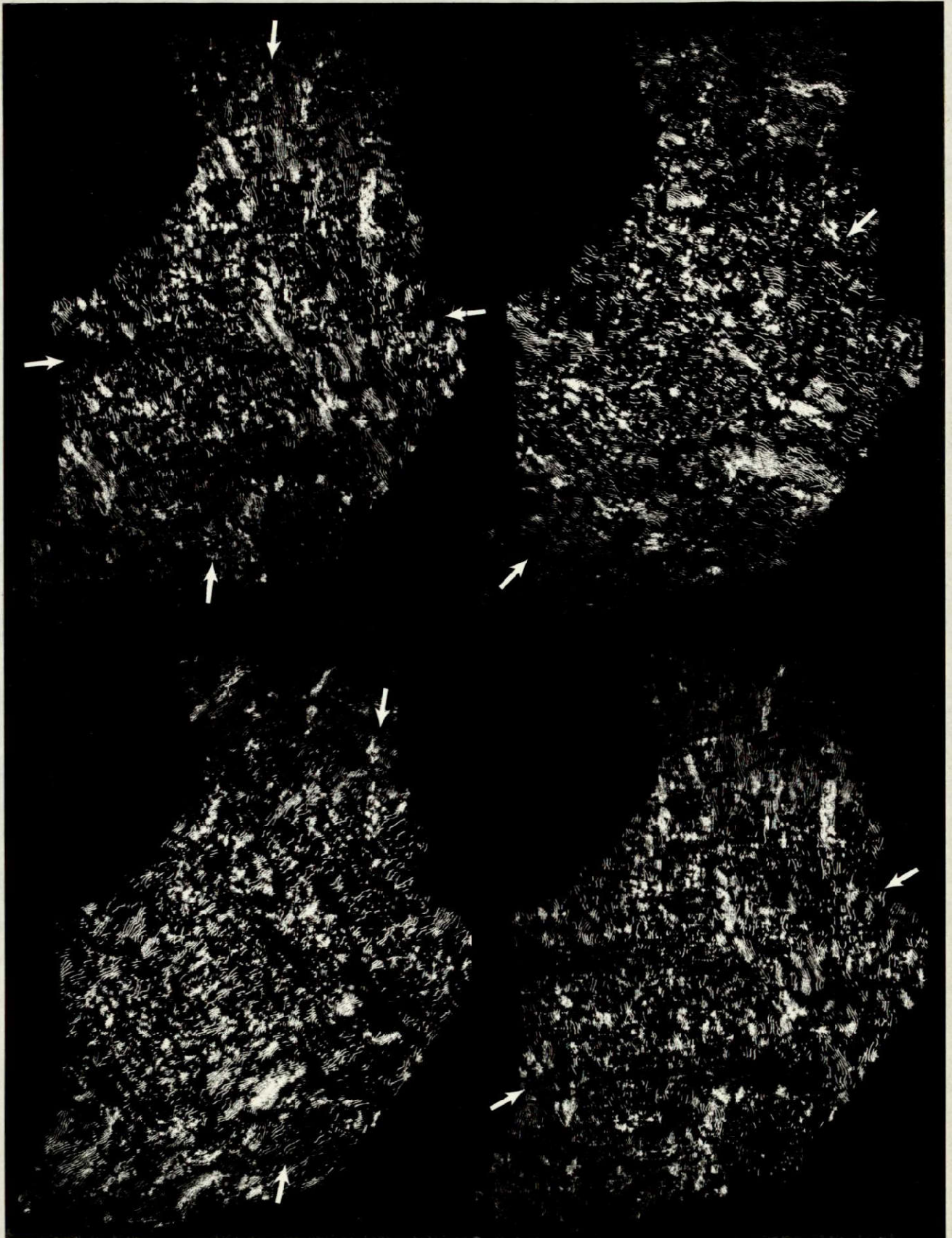

Fig. 15. Optically filtered Bouguer anomaly map. The arrows indicate some long lineaments extending across the Main Sulfide Ore Belt.

Bothnia to northern Sweden. The name owes to numerous Cu, Ni and other sulfide deposits contained in the belt. The geological nature of the belt has been discussed in a number of papers (e.g., Paarma and Marmo 1968, Mikkola and Niini 1968, Gaál 1972, Kahma 1973, Hietanen 1975, Talvitie 1975 and 1976, Mikkola and Vuorela 1976).

As the color combined maps did not give convincing evidence of the significance of the Landsat lineaments of southern Finland, they were investigated by other means. Coherent optical directional (90°) filtering was applied to the Bouguer anomaly map. This revealed a number of lineaments of southern Finland (Plate III) (cf. Tuominen and Kuosmanen 1976, report IV).

7.2.3 Significant fracture zones

In the present report the word 'fracture' means a narrow zone of intensive deformation.

The lineaments observed in the color-viewer combinations of different maps are 2-20 km wide and up to 300 km long. In the Landsat mosaics (Figs. 12 and 13) many of these lineaments are narrower and sharper, usually only 5 km or less wide, and therefore more readily observable. This does not, however, apply to all cases. In northern Finland, the important set of lineaments trending 15° - 27° (Plate I) was observed in the Landsat mosaics'

only after having first been recognized on the color-composite maps.

The lineaments of Plate III occur in both geophysical and geomorphological maps and mostly also in the Landsat mosaics. It is obvious, therefore, that they are real bedrock features, which hardly admit of any explanation other than being extensive fracture zones. Their surface manifestations are frequently topographic ramps and valleys. It is not impossible, however, that some of the lineaments may result from other kind of structures as, for instance, folds with horizontal axes.

The fracture zones of each subparallel set seem to appear at fairly constant intervals. A tendency of this sort is also supported by the distribution of the isolated maxima in the Wiener-spectrum of Bouguer anomalies (Fig. 9a). The relationship between the fracture net and the maxima of the Wiener-spectrum of Bouguer anomalies can be seen if the net (Plate I) is schematized (Plate Va) and its Wiener-spectrum estimated (Plate Vb). The solid circles in Plate Vb correspond, within certain deviation limits, to the existent network of semi-parallel fractures of Plate Va. It is probably not an accident that the maxima of the Wiener-spectrum (Plate Vb) of the existing fractures coincide with the natural maxima of the Wiener-spectrum (Fig. 9a) of Bouguer anomalies. The fit is seen by superposing Plate Vb on Fig. 9a. This result suggests that the fractures determine the pattern of gravity anomalies.

The letters A and B in Plate Vb indicate the possible frequencies of fractures subparallel to the single fractures A-A and B-B in Plate Va. These frequencies are suggested by maxima in the Wiener-spectrum of Bouguer anomalies (Fig. 9a) in the respective directions, 290° and 50° . Several lineaments which apparently result from these sets of fractures are visible in the Landsat mosaics. The letters C and D in Plate Vb show the locations of two significant peaks in the Wiener-spectrum of Bouguer anomalies. These peaks still await a structural explanation.

The intervals of subparallel fractures (Table 5, column 2) can be interpreted as block dimensions. Some of the blocks separated by these fracture sets have a tendency to show a characteristic color in Fig. 10. Many of the block boundaries coincide with the continuations of the second-order faults of Belyaev et al. (1976) on the Russian side.

In northern Finland, particularly, the known ore deposits and indications clearly occur along the lineaments of the fracture zones. This, of course, might result partly from a higher outcropping density along the related rams and valley slopes.

Some characteristics of the different fracture sets are given in Table 5. They have been derived from the map of prominent lineaments (Plate III), the map of ores and ore indications (Plate IV) and the Wiener-spectrum of Bouguer anomalies (Fig. 9a). Therefore Table 5 mainly concerns northern Finland. The

results are not contradictory to those obtained in the Landsat-1 program (Tuominen and Aarnisalo 1976).

Fracture trend	Intervals of subparallel fractures km	Associated base-metal occurrences
290°	35	Fe, Cu (Zn,Pb)
300°-315°	70 (or 35)	Fe, Ni (Cr), Cu (Zn,Pb)
330°	100 (or 50)	Fe, Cu (Zn,Pb)
15°-27°	30	Fe, Cu (Zn,Pb)
45°-55°	35	Fe, Cu (Zn,Pb), Ni (Cr)
80°	70 (or 35)	Fe, Ni (Cr)

Table 5. Trends, spacings and base-metal occurrences of the most significant fracture sets.

8 CONCLUSIONS

Landsat images provide a new tool for locating structures relevant to ore prospecting. However, the best results are obtained when images, preferably in the form of mosaics, are used together with geophysical, geological and geomorphological maps.

The imagery is useful for mapping vegetation, the Quaternary soil cover and their humidity. These features were found to control nearly all the graytones of the different bands. This investigation did not reveal whether the chemical composition of the bedrock affects these graytones.

Lithologically different bedrock units are best discriminated by image textures. This applies, particularly, to granitoids and schists.

Large faults, folds, layering and circular units are observable.

Analysis of spatial frequency components of maps and pictures makes it possible to differentiate between spatial components corresponding to deep or surface structures. In this way, observation of lineaments becomes less controversial. Connected to this, when Fourier-spectra are used instead of usual rose diagrams, the dimensions of the structures of different strikes also become estimated.

In northern Finland, the known ore deposits and showings are generally distributed along the major fracture zones revealed by lineaments in both Landsat mosaics and color-combined geological, geophysical and geomorphological maps. These fracture zones, which form a fairly regular network of lineaments trending 330° , $300^{\circ} - 315^{\circ}$, $15^{\circ} - 27^{\circ}$, 80° , 290° and $45^{\circ} - 55^{\circ}$, may be considered as reasonable targets for ore prospecting.

9 PUBLICATIONS, REPORTS, ETC.

The publications and reports covering the investigation period of program 28600 are indicated by an asterix (*) in the list of references.

10 RECOMMENDATIONS

- Developing further the classification of "large" (up to 30 km) texture samples of images and maps would be useful for discerning lithologic/structural units.
- Color mosaics over Finland ought to be compiled and studied by spectral and spatial filtration. This procedure will still give numerous valuable hints for detecting large folds, layering and circular units. They can, of course, be tested by combination with geophysical maps and geological data.
- Systematic map analysis, based on separation and recombination of spatial-frequency components of these maps, is recommended for development according to the principles set forth in this paper. Optical and digital Fourier analysis can be used for this purpose. By this method, the local anomalies emerge in relation to the regional anomalies, and therefore relationships between large and smaller structures, especially faults, become more comprehensible.

- A good application for the methods of this investigation is to use them in a detailed structural study of, for example, one major fracture zone of Finland. To accomplish this we recommend a combined study of map and image transformations, field observations and 3-4 seismic profiles across the zone. The Main Sulfide Ore Belt is possibly the most yielding in this respect. It is believed that here a careful structural study would reveal ore deposits of also deeper positions.

- In general, a consequential extension of the present investigation would be to compile field data to supplement the knowledge of the regional linear structures brought to light. Important tasks would be to explain the relationship of the metamorphic facies, formational setting, meso-scale tectonic elements and polyphase deformation to the deep faulting. In this work, Landsat data may be used as one 'channel' in a multi-component system of other maps.

11 REFERENCES

- Aarnisalo, J. (1977) Fracture patterns of Finnish Lapland.
In: Körtman, C. (editor) Fault tectonics in the eastern part of the Baltic Shield. Helsinki, (*)
- Aarnisalo, J., Mikkola, A.K. (1975) Fracture patterns of Finnish Lapland and their relation to ore deposits. Meeting of European Geological societies, Reading, U.K. Sept., 1975. Abstracts of keynote addresses and short communications. Univ. Reading. Reading, U.K. (*)
- Agterberg, F.P. (1974) Geomathematics. Elsevier.
- Baker, R.N. (1975) LANDSAT data: a new perspective for geology. Photogrammetric Engineering and Remote Sensing, Vol. 41, No. 10, 1233-1239.
- Belyaev, K., Proskuryakov, V., Korsakova, M., Rabinovich, Y., Zagorodny, V., Bylinski, R., Dolivo-Dobrovolski, A. (1976) The tectonic pattern of the eastern part of the Baltic Shield. In: Kortman, C. (editor) Fault tectonics in the eastern part of the Baltic Shield, Helsinki.
- Gaál, G. (1972) Tectonic control of some Ni-Cu deposits in Finland. 24th IGC, 1972 - Section 4.
- Gilluly, J. (1976) Lineaments - Ineffective guides to ore deposits. Economic Geology, Vol. 71, 1507-1514.

- Gol'braikh, I.G., Zabaluyev, V.V. and Mirkin, G.R. (1966)
Tectonic analysis of megajointing: A promising method
of investigating covered territories. International
Geology Review, 8, 9.
- Gol'braikh, I.G., Zabaluyev, V.V., Lastochkin, A.N., Mirkin,
G.R., Reinin, I.V. (1968) Morphostructural Methods for
the Tectonic Study of Covered Platform Oil and Gas Regions.
"NEDRA" Publishing House, Leningrad Division.
- Härme, M. (1961) On the Fault Lines in Finland. C.R. Soc.
geol. Finlande 33,25, 437-444.
- Heyl, A.V. (1972) The 38th parallel lineament and its relation-
ships to ore deposits. Economic Geology, 67, 879-894.
- Hietanen, A. (1975) Generation of potassium-poor magmas in
the northern Sierra Nevada and the Svecofennian of Finland.
Jour. Research U.S. Geol. Survey, 3, 6, 631-645.
- Kahma, A. (1973) The main metallogenic features of Finland.
Geol. Surv. Finland, Bull. 265.
- Kanestrøm, R. (1969) Seismic investigations of the crust and
upper mantle in Norway. Deep seismic sounding in northern
Europe, editor Andreas Vogel, Editorial Service, Swedish
Natural Science Research Council (NFR).

- Kuivamäki, A. (1977) Geologisten tekijöiden vaikutuksesta Landsat-kuvien harmaasävyihin. (On the correlation between geologic factors and greytones of Landsat imagery.) M.Sc. thesis, Arch. Dept. Geol., Univ. Helsinki. (★)
- Kuosmanen, V. (1975) Pohjois-Suomen Bouguer-anomaliat ja kallioperän suurrakenteet (Bouguer-anomalies and major bedrock structures in northern Finland) (in Finnish). M.Sc. thesis, Arch. Dept. Geol. Min., Univ. Helsinki. (★)
- Kutina, J. (1969) Hydrothermal ore deposits in the western United States: A new concept of structural control of distribution. *Science*, 165, 12, 1113-1119.
- Kutina, J. (1971) A contribution to the correlation of structural control of ore deposition between North America and Western Europe. *Proc. IMA-IAGOD Meetings "70"*, Tokyo, 70-75.
- Lattman, L.H. (1976) Remote sensing in mineral exploration from ERTS imagery. Abstract of paper read at GSFC, Greenbelt, Md. on Oct. 1976.
- Mikkola, A. and Niini, H. (1968) Structural position of ore bearing areas in Finland. *Bull. Geol. Soc. Finland* 40, 17-33.
- Mikkola, A. and Vuorela, P. (1974) Ore-bearing areas and linearity in Finnish bedrock. Abstract. XI. Nordiska Geologiska Vintermötet, Oulu/Uleåborg 1974 Jan. 3-5, B. Abstracts, program, deltagarlista och allmänna instruktioner. Univ. Oulu, Oulu.

- Mikkola, A. and Vuorela, P. (1976) Deep seated fractures and metallogeny of Finland. In: Kortman, C. (editor) Fault tectonics in the eastern part of the Baltic Shield, Helsinki.
- Nanyaro, J.T. (1975) On the geology and lineaments of northern Finnish Lapland, With special reference to the Lemmenjoki and Ivalo gold districts. M.Sc. thesis. Arch. Dept. Geol. Min., Univ. Helsinki. (*)
- Paarma, H. (1963) On the Tectonic Structure of the Finnish Basement, Especially in the Light of Geophysical Maps. Fennia 89, 1, 33-36.
- Paarma, H. and Marmo, V. (1961) Eräistä suurrakenteista Suomen geologiaan sovellettuina. Summary: On some large structures with an application into geology of Finland. Terra 73, 78-86.
- Paarma, H. and Talvitie, J. (1976) Deep fractures - Sokli Carbonatite. Dept. of geophysics, University of Oulu, Contribution no. 65. (*)
- Parvis, M. (1950) Drainage pattern significance in airphoto identification of soils and bedrocks. Photogram. Eng. 16, 387. (ref. Reeves et al. 1975 Terrain and minerals: assesment and evaluation. Manual of remote sensing II, p. 1106. Amer. Soc. Photogram).

- Penttilä, E. (1972) Crustal structure in Fennoscandia from seismological and gravimetric observations. Ann. Acad. Sci. Fenn., A. III, 110, 38 p.
- Räsänen, J. (1975) Etelä-Suomen kallioperäkarttojen ja Landsat kuvatekstuuriin visuaalinen vertailu (in Finnish). (Visual comparison of geological bedrock maps and Landsat image textures in southern Finland) In-house report for Landsat program 28600. Arch. Dept. Geol. Min., Univ. Helsinki. (*)
- Strömberg, A.G.B. (1976) A pattern of tectonic zones in the western part of the East European platform. Geologiska Föreningens i Stockholm Förhandlingar, Vol. 98, 22-243. Stockholm.
- Talvitie, J. (1971) Seismotectonics of the Kuopio region, Finland. Bull. Comm. géol. Finlande 283.
- Talvitie, J. (1975) Fractures, dynamic model and Ni-Cu mineralized basic intrusives in Central Finland. Geol. Surv. Finland, Report of investigation No. 10.
- Talvitie, J. (1976) Fracture zone of Ladoga - Bothnian Bay. Dept. of Geophysics, University of Oulu, Contribution No. 64. (*)
- Talvitie, J. (1977) Seismotectonics of northern Finland and the Fennoscandian Shield. Dept of Geophysics, University of Oulu, Contribution No. 82. (*)

- Tuominen, H.V. (1975) Investigation of LANDSAT-imagery on correlations between ore deposits and major shield structures in Finland. Quarterly progress report I., July 1975 - Sept. 1975. NASA-CR-145 752. (*)
- Tuominen, H.V. and Aarnisalo, J. (1976) Major crustal fractures in the Baltic Shield. Final report of program SR no. 580-03, NASA E77-10027. (*)
- Tuominen, H.V., Aarnisalo, J., Söderholm, B. (1973) Tectonic patterns in the central Baltic Shield. Bull. Geol. Soc. Finland, 45, 205-217.
- Tuominen, H.V., Kuosmanen, V. (1975) Investigation of LANDSAT-imagery on correlations between ore deposits and major shield structures in Finland. Quarterly progress report II, Oct. 1975 - Dec. 1975, NASA E76-10372. (*)
- Tuominen, H.V., Kuosmanen, V. (1976) Investigation of LANDSAT-imagery on correlations between ore deposits and major shield structures in Finland. Quarterly progress reports III-IV, Jan.-June 1976, NASA E76-10390. (*)
- Vuorela, P. (1973) Ruhjevyöhykkeet ja niiden suhde malmi-esiintymiin ja malmeihin Suomessa (Fracture zones and their relation to ore showings and deposits in Finland; in Finnish), 53 p. Ph.Lic. thesis. Arch. Dept. Geol. Min., Univ. Helsinki.

Appendix to Final report of the
Landsat Investigation No. 28600

Ice investigation in the Gulf of Bothnia

The Finnish-Swedish sea ice investigation project in the Gulf of Bothnia, called "Sea Ice 75", has been completed. For the part based on Landsat-2 data the program was included as a secondary discipline in the Landsat follow-on investigation no. 28600. The investigators report following:

"The information from LANDSAT-2 is of very good quality. The resolution is about 80 m which makes it possible to identify different ice parameters, such as large ice floes and leads. The areal coverage is good enabling large-scale mapping for ice forecasting. There are, however, severe restrictions in the availability of the LANDSAT information. It is obtained only 2-3 times every 18th day and only on request from NASA." (Blomquist et al. 1976 p. 19).

References

- Blomquist, Å., Pilo, C., Thomson, T. (1976) Sea Ice 75, Summary Report. Styrelsen vintersjöfartsforskning (Sjöfartsverket, Sverige; Sjöfartsstyrelsen, Finland), Forskningsrapport No. 16:9. Norrköping 1976.

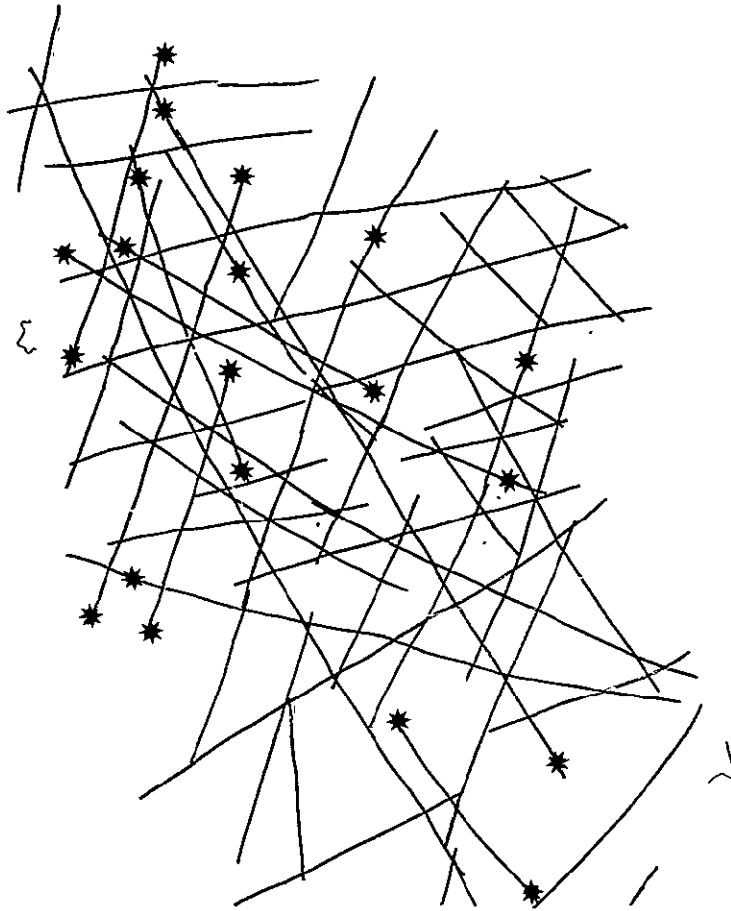

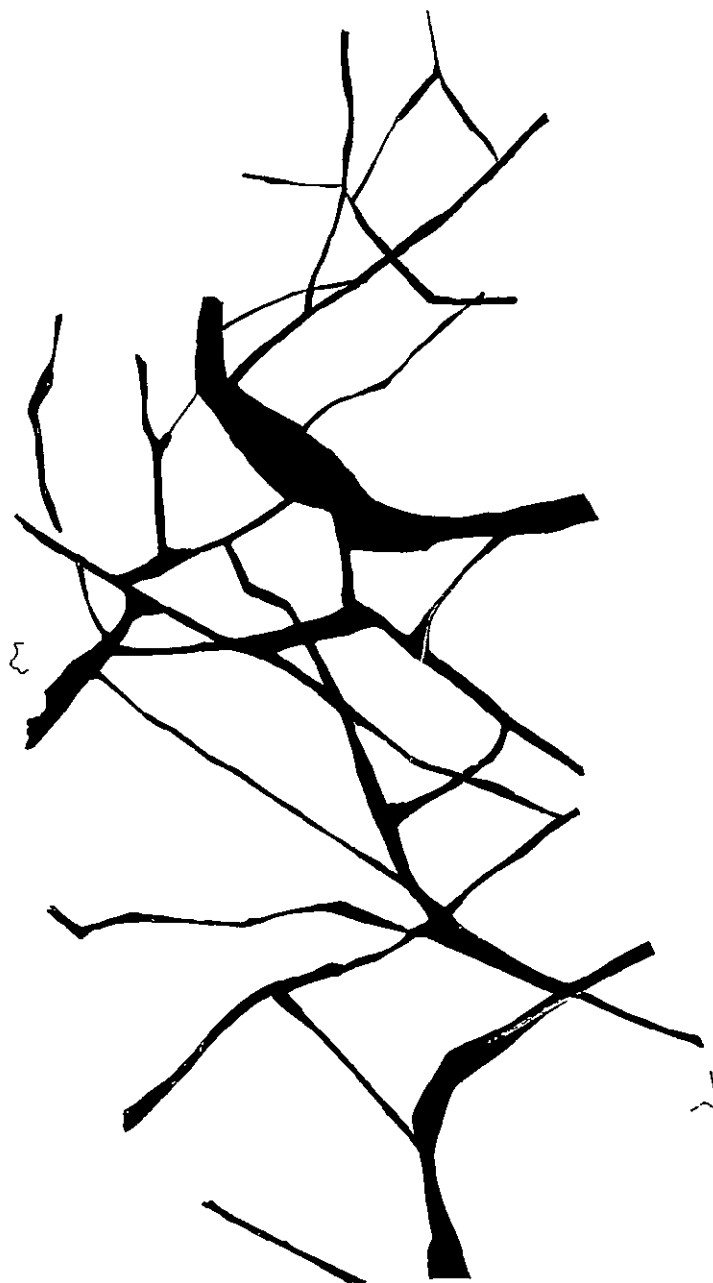

PROMINENT LINEAMENTS IN
LANDSAT TEST AREAS OF
FINLAND

OVERLAY MAP FOR LANDSAT MOSAICS
1:5 000 000

* LINEAMENTS OBSERVABLE
IN THE MOSAICS

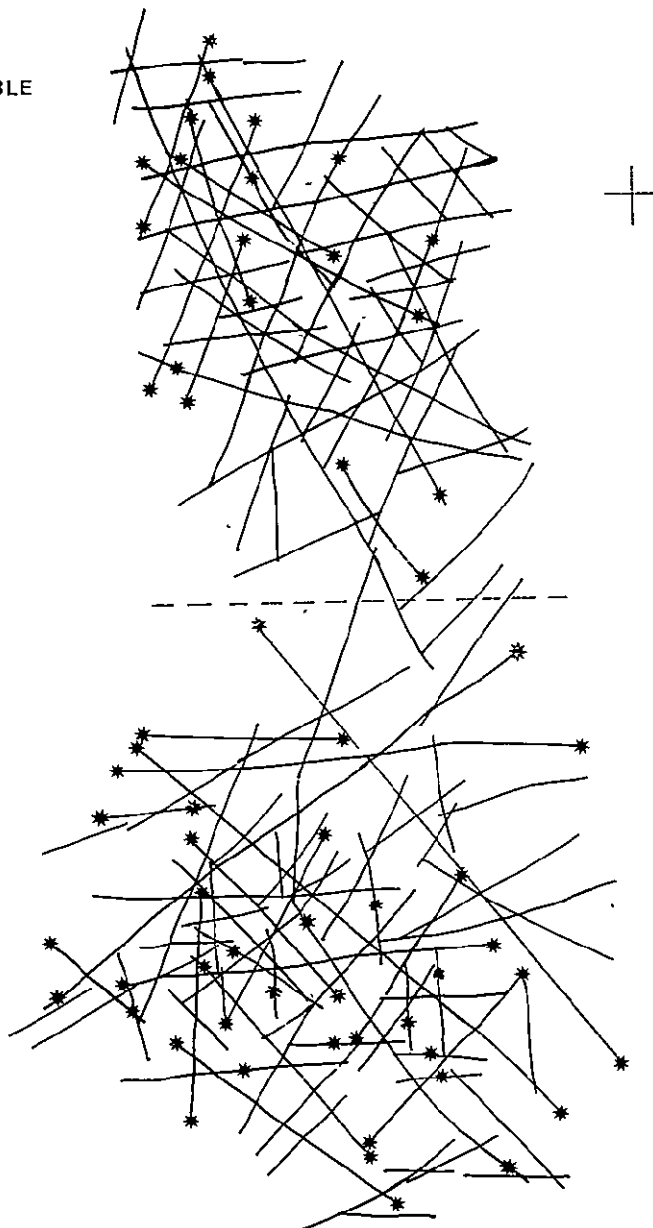

ORES AND ORE-SHOWINGS

1:5 000 000

- + Ni
- Fe
- ▲ Cu Zn Pb

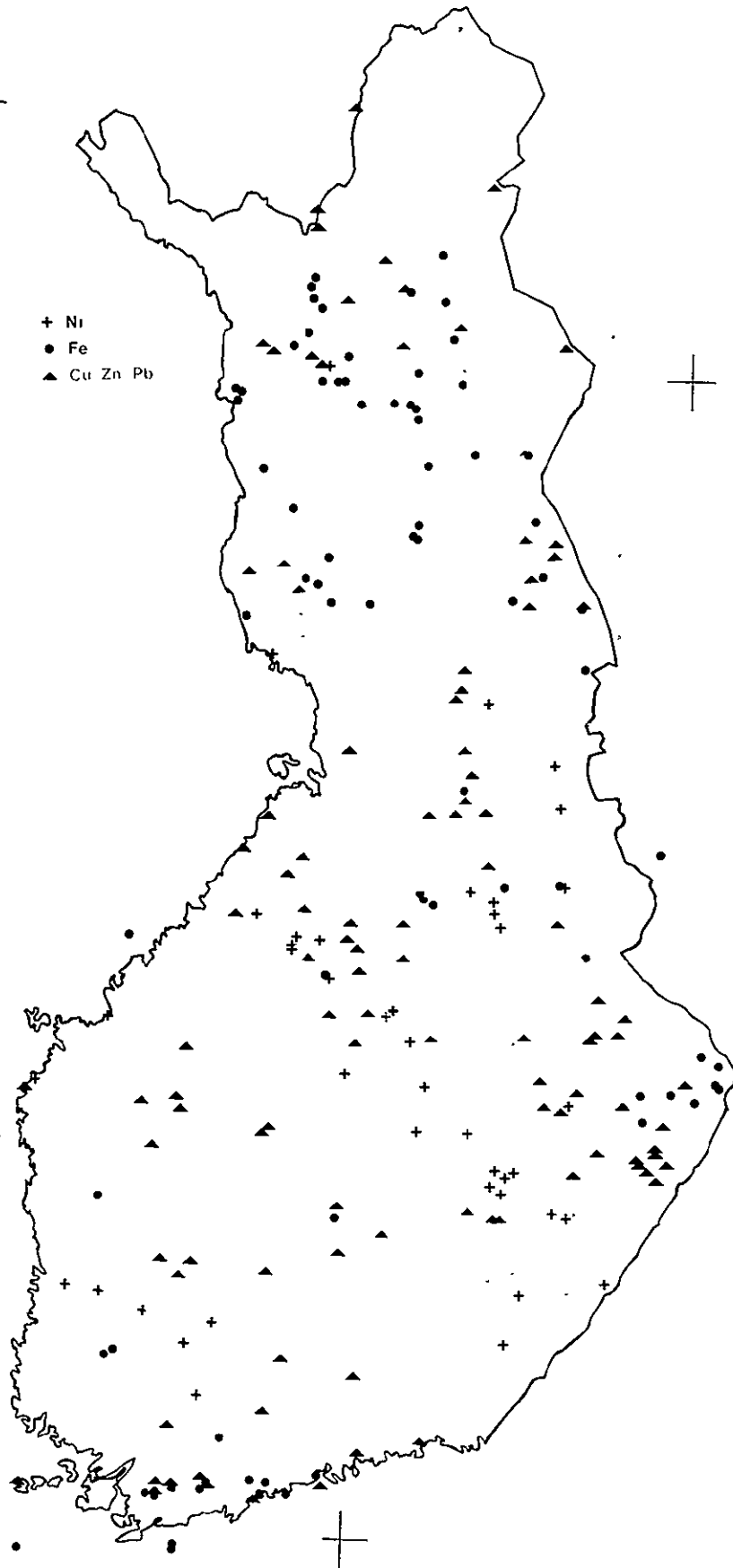

Tuomiinen, H.V and Kuosmanen, V. (1977) Investigation of LANDSAT imagery on correlations between ore deposits and major shield structures in Finland. Final report

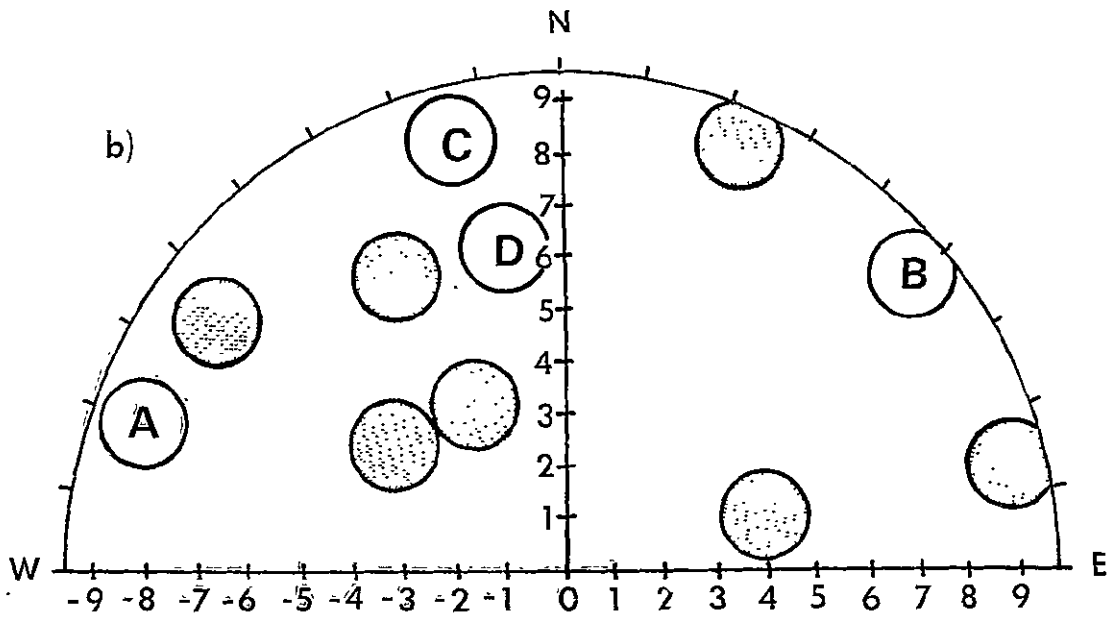
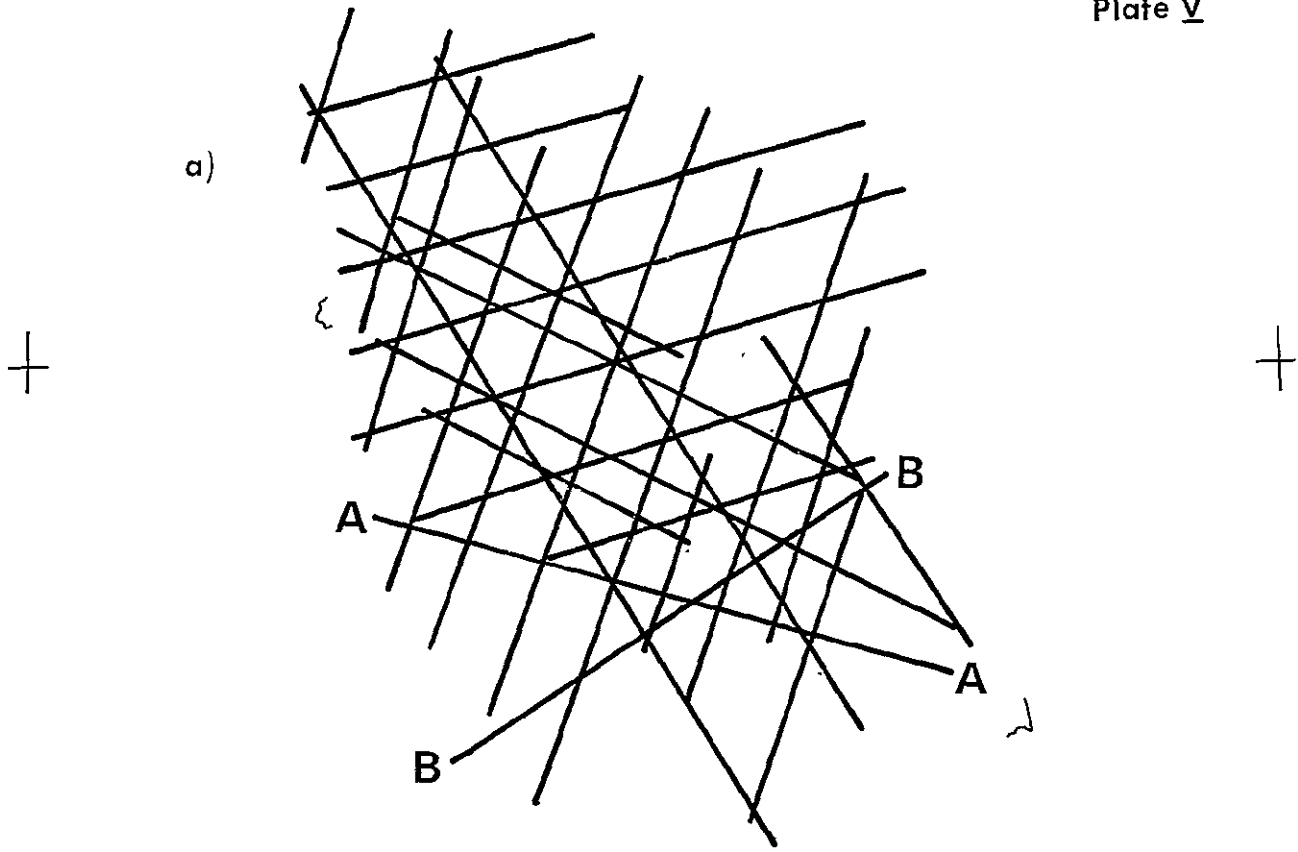

Tuominen, H. V. and Kuosmanen, V. (1977) Investigation of LANDSAT imagery on correlations between ore deposits and major shield structures in Finland. Final report.

PLATES, Please Film