

# The Main Peculiarities of the Processes of the Deformation and Destruction of Lunar Soil

A. K. Leonovich, V. V. Gromov, A. D. Dmitriyev,  
V. N. Penetrigov, and P. S. Semenov  
*A. I. Ioffe Leningrad Physical-Technical Institute  
Academy of Sciences, U.S.S.R.*

V. V. Shvarev  
*All-Union Scientific Research Institute  
of Optical-Physical Measurements, U.S.S.R.*

The main results of study of the physical and mechanical properties of lunar soil, obtained by laboratory study of samples returned from the Moon by Luna 16 and Luna 20, as well as by operation of the self-propelled Lunokhod 1 and Lunokhod 2 on the surface of the Moon, are analyzed in the report. All studies were carried out by single methods and by means of unified instruments, allowing a confident comparison of the results obtained.

The investigations conducted allowed the following values of the main physical-mechanical properties of lunar soil to be determined: in the natural condition the solid density corresponds to the porosity of 0.8; the modal value of the carrying capacity is 0.4 kg/cm<sup>2</sup>; adhesion is 0.04 to 0.06 kg/cm<sup>2</sup>; and the internal angle of friction is 20 to 25°.

The main mechanisms of deformation and destruction of the soil are analyzed in the report, and the relationships between the mechanical properties and physical parameters of the soil are presented.

The return to Earth of samples of lunar soil from different regions of the Moon's surface and the study of properties of the soil in the natural state permit a number of generalizations to be made about the processes of deformation and destruction of the lunar soil. One of the important results of studying the constitution, structure, and physical and mechanical properties of lunar soil has been the discovery of the relative uniformity of the particle size distribution. In addition, information has been gathered concerning the shapes and specific gravity of particles from various sections of the lunar surface. Irregularities in structure of the lunar surface and change in physical-mechanical properties of the lunar soil within broad limits may be explained, to a considerable extent, by different proportions of soil compaction. Despite certain differences in the physical and mechani-

cal properties of the soil obtained by different investigators, some general regularities that can be considered to be characteristic of lunar soil were revealed.

## Nature and Destruction of Lunar Soil Samples

The processes of destruction of lunar soil samples were investigated in a Coulomb apparatus, for two states of the soil: (1) extremely loose and (2) compacted to a density of 1.6 g/cm<sup>3</sup>.

The Coulomb apparatus is a small box which has transparent walls and a movable partition inside (ref. 1).

The soil in the loose state is deformed by lateral pressure, without formation of visible crags or slip lines (fig. 1a). If the deforma-

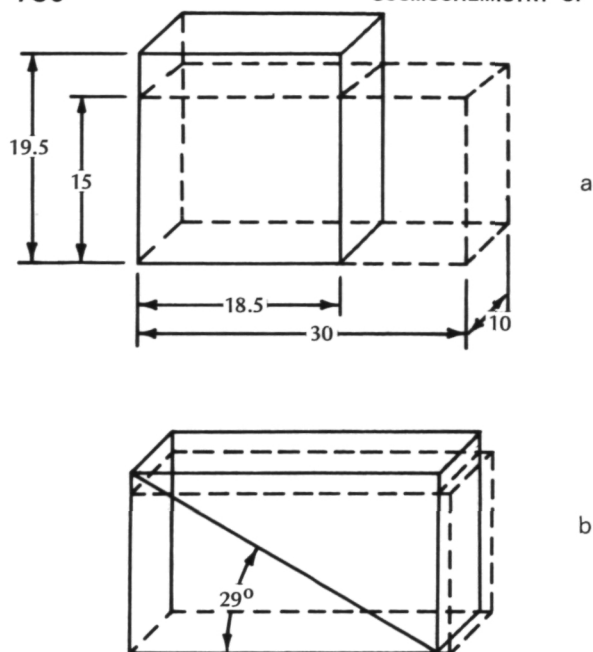

Figure 1.—Diagram of sample deformation: (a) loose state; (b) compacted state.

tion in the Coulomb instrument is considered as a biaxial compression, the coefficient of lateral expansion of the soil,  $\mu$ , and the coefficient of lateral pressure,  $\xi$ , can be calculated.

For Luna 16 and Luna 20 soil samples in the loose state, the following values were obtained:  $\mu = 0.44 - 0.45$ ;  $\xi = 0.78 - 0.82$ .

On application of lateral pressure to compacted soil, splitting of the sample occurred along a plane inclined to the principal stress by an angle of  $22^\circ$  for the Luna 16 sample and  $29^\circ$  for the Luna 20 sample (fig. 1b). These correspond to internal angles of friction of  $46^\circ$  and  $32^\circ$  (refs. 1 and 2).

## Strength Characteristics of Lunar Soil

The main strength indicators of fine-grain, weakly bound soils are the shear strength characteristics (ref. 3).

The shear strength of lunar soil samples was determined in a flat, single-shear instrument, by the supercompaction method.

Graphs of the shearing resistance, plotted in "shear stress"—"normal pressure" coordinates, are shown in figure 2, and the principal portion of them is described well by the Coulomb equation:

$$\tau = c + p \tan \phi \quad (1)$$

where  $\tau$  is the shear stress ( $\text{kg}/\text{cm}^2$ ),  $c$  is the corrected adhesion ( $\text{kg}/\text{cm}^2$ ),  $p$  is the normal shear pressure ( $\text{kg}/\text{cm}^2$ ), and  $\phi$  is the internal angle of friction.

The shear strength parameters depend to a great extent on the compaction pressure (fig. 3).

In the incoherent state, the soil has a negligible adhesion and internal angle of friction. In proportion to increasing compaction pressure, an increase in the internal angle of friction and initial adhesion occurs. This can be explained by an increase in the number of contacts between particles and an increase in the quantity of fused particles.

At compaction pressures over  $0.4 - 0.5 \text{ kg}/\text{cm}^2$ , the number of contacts increases negligibly, and the internal angle of friction and initial adhesion approach a certain steady-state value. Stabilization of the initial adhesion values, on the other hand, is also explained by the fact that, in the process of shear in the absence of normal pressure, decompaction of the soil takes place, and the mutual adhesion between particles decreases. With compaction pressure, decompaction of soil does not take place during shear, and, with pressures greater than a certain value, the soil is still more strongly compacted during shear. This phenomenon may explain the linear nature of the dependence of the normalized adhesion on the compaction pressure. The nature of the occurrence of additional compaction and decompaction of soil in shear tests is shown in figure 4. The following characteristic points can be distinguished in these curves:

1. Intersection with the normal pressure axis during shear, when the sample retains its volume in the shear process
2. Intersection with the vertical axis (magnitude of decompaction of the soil, in the absence of normal shear pressure)

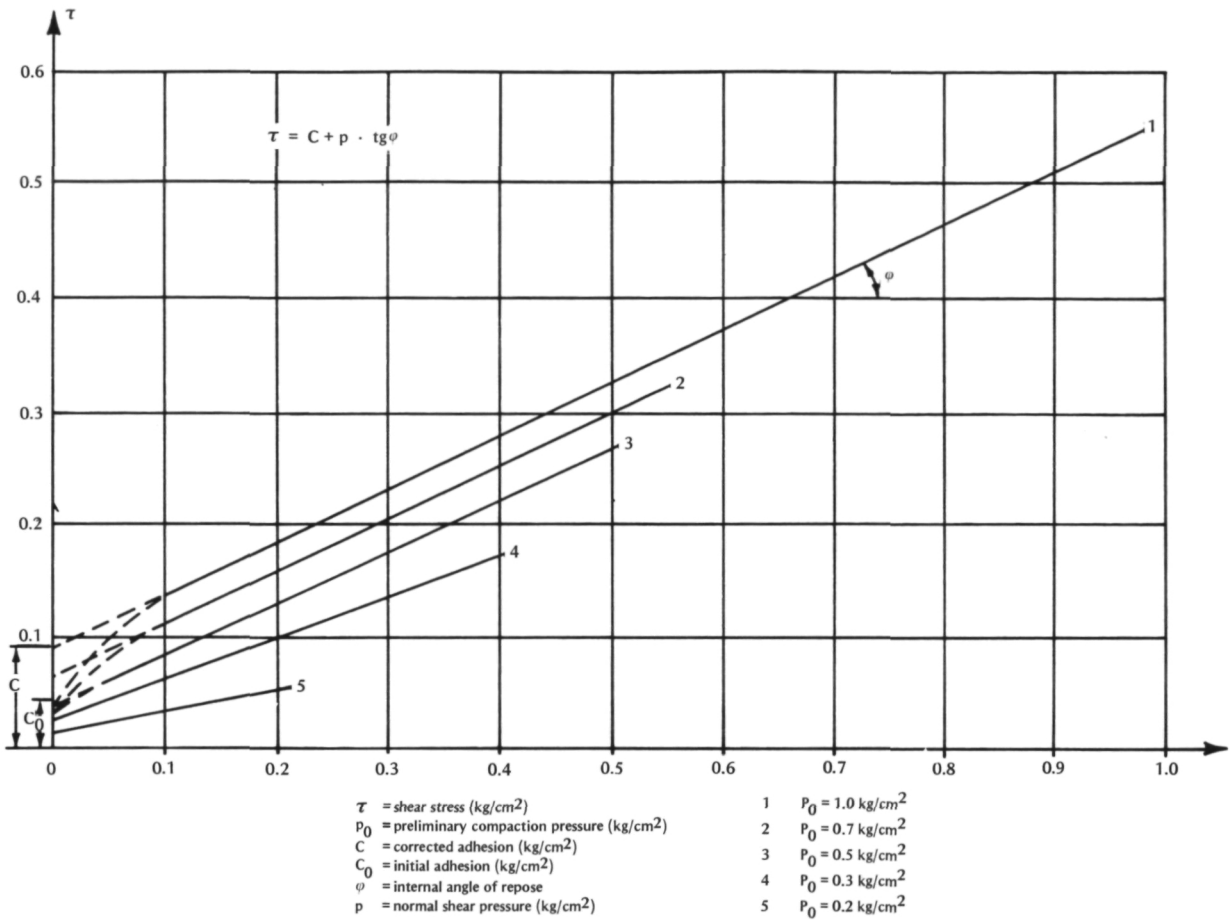

Figure 2.—Shear strength curves. For curve 1,  $p_0 = 1.0$ ; 2,  $p_0 = 0.7$ ; 3,  $p_0 = 0.5$ ; 4,  $p_0 = 0.3$ ; 5,  $p_0 = 0.2$ .

In the first case, it can be considered that the external normal pressure is equalized by an equivalent internal pressure in the soil, and, therefore, there is no additional change in volume of the soil. The magnitude of this pressure can be considered to be "critical" ( $p_c$ ) for a given state of the soil.

In the second case, the amount of soil decompaction in the absence of normal pressure indicates the degree of incoherence (decrease in soil porosity). The curve of decompaction versus compacting load is similar to the soil subsidence curve in compression compacting, and in this case the soil has a tendency to go to a state corresponding to an equivalent compaction pressure ( $p_b$ ).

The quantity  $p_c$  can be considered as the

equivalent internal pressure in the soil, which determines the force of adhesion and which is the residual stress from the compacting load. This stress is preserved if the internal normal pressure in the shear process is equal to or exceeds  $p_c$  for a given state of the soil. Otherwise, the soil will loosen, and the new state will correspond to a decreased value of  $p_c$ . In the absence of normal pressure in the shear process,  $p_c = p_b$ .

Analysis of the experimental data on shear strength has demonstrated that  $p_c$  depends linearly on compaction pressure, and  $p_b$  depends little on the degree of compaction of the soil and can serve as a certain characteristic value for determination of shear strength.

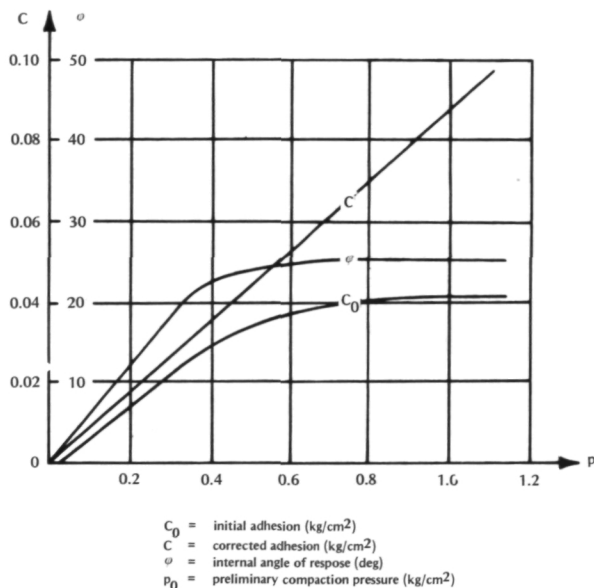

Figure 3.—Shear strength parameters as a function of load.

With the peculiarities revealed in the process of shear of lunar soil samples taken into account, the interconnection between shear stress and normal pressure can be represented in the following form (fig. 5):

$$\tau = C_0 + p \times \tan \phi + C_2 \quad (2)$$

where  $C_2$  is the supplementary value of the adhesion strengths determined by compaction of the soil (cross-hatched part of fig. 5). As is evident from this curve,  $C_2 = 0$  at  $p = 0$  and reaches its maximum value at pressures above the critical pressure. The following expression satisfies this condition of change in  $C_2$ :

$$C_2 = C - C_0) \times (1 - e^{-Kp}) \quad (3)$$

where  $K$  is an exponent (cm<sup>2</sup> × kg).

Then, the equation for determination of the shear strength will have the form:

$$\tau = C_0 + P \times \tan \phi + (C - C_0) \times (1 - e^{-Kp}) \quad (4)$$

The quantities  $C_0$  and  $C$  can be determined from  $p_b$  and  $p_c$ :

$$\begin{aligned} C_0 &= p_b \times \tan \phi \\ C &= p_c \times \tan \phi \end{aligned} \quad (5)$$

Taking this equation into account, (2) takes the following form:

$$\tau = \tan \phi \times [p_c - (p_c - p_b) \times e^{-Kp} + p] \quad (6)$$

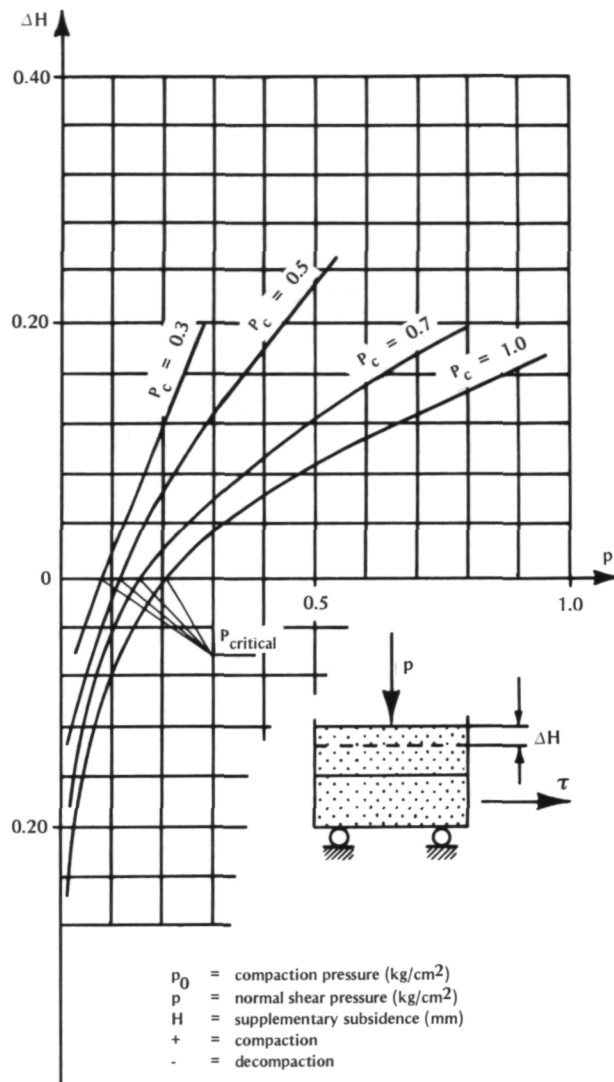

Figure 4.—Change in sample deformation during shear 1— $p_0 = 0.5$  kg/cm<sup>2</sup>; 2— $p_0 = 0.7$  kg/cm<sup>2</sup>; 3— $p_0 = 1.0$  kg/cm<sup>2</sup>.

Exponent  $K$  can be determined, on condition that, at  $p = p_c$ , the magnitude of the supplementary adhesion is sufficiently close to its maximum value. Practically, it can be considered that this condition is satisfied if the cofactor  $(1 - e^{-Kp}) = 0.9$ . Proceeding from this condition:

$$K = \frac{1}{\log e p_c} = \frac{2.3}{p_c} = \frac{2.3 \times \tan \phi}{C} \quad (7)$$

Then, formula (6) can be written in the following form:

$$\tau = C - (C - C_0) \times \exp \left[ -\frac{2.3 p \times \tan \phi}{C} + p \tan \phi \right]$$

or

$$\tau = \tan \phi [p_c - (p_c - p_b)] \times \exp \left[ -\frac{2.3 p \times \tan \phi}{C} + p \right] \quad (8)$$

Nonlinearity of the initial part of the shear strength curve leads to a considerable change in the internal angle of friction, determined from the tangent of the slope angle tangent to the shear strength curve.

For any point, the internal angle of friction will be

$$\tan \phi_i = \frac{d\tau}{dp} = \tan \phi \left[ (C - C_0) \times \frac{2.3}{C} \times \exp \left[ -\frac{2.3 p \times \tan \phi}{C} + 1 \right] \right] \quad (9)$$

The initial internal angle of friction, i.e., at  $p = 0$ , is

$$\tan \phi_0 = \tan \phi \times \left[ \left(1 - \frac{C_0}{C}\right) \times 2.3 + 1 \right] = \tan \phi \left[ \left(1 - \frac{p_b}{p_c}\right) 2.3 + 1 \right] \quad (10)$$

A comparison of the determination of  $\tan \phi_0$  by this formula and in the Coulomb instrument has shown that they coincide well,

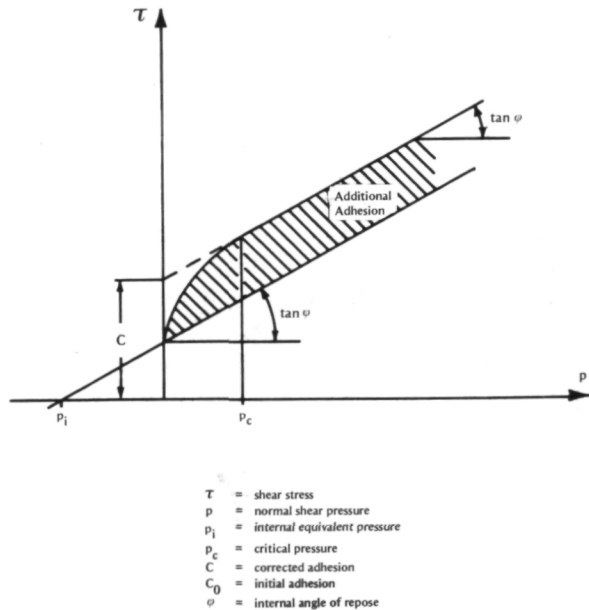

Figure 5.—Curve for determination of adhesion in soil.

which confirms the correctness of the previous conclusions as to the peculiarities of the development of processes of shear of the lunar soil.

Qualitative values of the shear strength parameters for the Luna 16 and Luna 20 samples are quite close to each other.

Similar results were also obtained for finely pulverized basalt, with a particle size composition close to that of the lunar soil.

### Peculiarities of Lunar Soil Deformation Processes

The most important deformation characteristics of soil, which have great scientific and applied importance, are

1. Compressibility
2. Process of intrusion of a die into the half-space of the soil.
3. Soil deformation in the shear process.

Compressibility of the lunar soil was studied on the samples returned by Luna 16 and Luna 20. The study was carried out on soil samples 6 cm<sup>3</sup> in size. The maximum value of the compaction pressure was 1 kg/cm<sup>2</sup>. The results of the tests are shown in figure 6. Analysis of the behavior of the com-

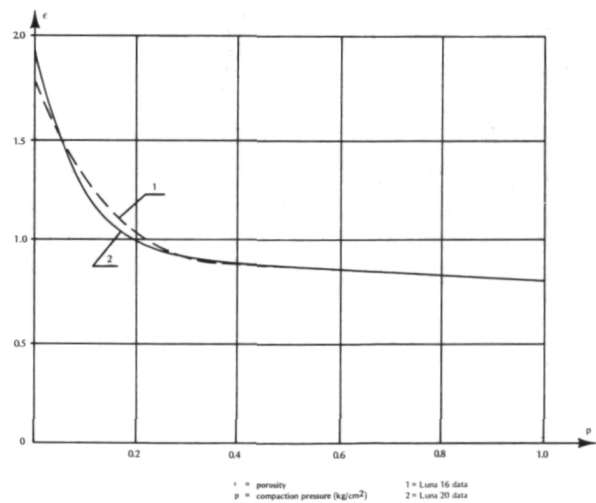

Figure 6.—Lunar soil compressibility curves: (1) from Luna 16 data; (2) from Luna 20 data.

pressibility curve permitted two soil compaction mechanisms to be distinguished.

In the initial stage of compression of the soil, a decrease in porosity takes place, mainly by means of displacement and more dense packing of the aggregates and particles. With further increase in load, destruction of the aggregates and displacement and compaction of the particles themselves begins; in this case, the load is transmitted in the bulk of the soil, through contacts between the particles. In the 0.5 to 1.0 kg/cm<sup>2</sup> compaction pressure range, the process of compacting the particles and increasing the number of contacts between them is basically completed; subsequent compaction of the soil takes place by means of destruction of the particles at their points of contacts with one another.

The lunar soil compressibility curve is approximated sufficiently well by the following formula:

$$\varepsilon = A \times e^{K_1 \times p} + B \times e^{-K_2 \times p} \quad (11)$$

$\varepsilon$  is the density;  $A$ ,  $B$ ,  $K_1$ , and  $K_2$  are constants. In this case,  $A + B = \varepsilon_0$  is the porosity of the maximally incoherent soil. The compaction coefficient,  $a$ , for any point on the compressibility curve described by equation (11), will equal:

$$a = \frac{d\varepsilon}{dp} = K_1 \times A \times e^{K_1 \times p} - K_2 \times B \times e^{-K_2 \times p} \quad (12)$$

In the maximally incoherent state (at  $p = 0$ ), the compaction coefficient equals

$$a_0 = -K_1 \times A - K_2 \times B$$

The modulus of deformation,  $E$ , from the decompression curve can be determined by the following formula:

$$E = \frac{1 + \varepsilon_0}{-K \times A \times e^{-K_1 \times p} - K_2 \times B \times e^{-K_2 \times p}} \left( 1 - \frac{2\xi^2}{1 + \xi} \right) \quad (13)$$

where  $\xi$  is the lateral pressure coefficient.

At small compaction pressures ( $< 0.5$  kg/cm<sup>2</sup>), formulas (11, 12, 13) can be simplified somewhat, if the second term in the formula is assumed to be constant. Then, for the compressibility curve we will have:

$$\varepsilon = \varepsilon_\infty + (\varepsilon_0 - \varepsilon_\infty) \times e^{-K_1 \times p} \quad (14)$$

where  $\varepsilon_\infty$  is a certain maximum value of the porosity in compaction.

We then obtain, for the compaction coefficients:

$$a_0 = -K_1 \times (\varepsilon_0 - \varepsilon_\infty) \quad \text{and} \quad a = a_0 \times (1 - p) \quad (15)$$

where  $D = \frac{\varepsilon_0 - \varepsilon}{\varepsilon_0 - \varepsilon_\infty}$  is the coefficient of relative density of the soil.

The modulus of deformation will equal:

$$E = \frac{1 + \varepsilon_0}{a_0 \times (1 - D)} \times f(\xi),$$

$$E = \frac{(1 + \varepsilon_0) \times e^{K_1 \times p}}{-K_1 \times (\varepsilon - \varepsilon_\infty)} \times f(\xi)$$

$$E = \frac{1 + \varepsilon_0}{-K_1 \times (\varepsilon - \varepsilon_\infty)} \times f(\xi)$$

where

$$f(\xi) = \left( 1 - \frac{2\xi^2}{1 + \xi} \right) \quad (16)$$

It is easy to develop the relationship of the main parameters of compressibility with degree of compaction of the soil, magnitude of the compaction pressure, and the physical state of the soil, from equations (13, 14, 15, 16).

In removing the compression load from a sample of soil in a compression instrument, its porosity is practically unchanged, since the recovery from deformation of the soil is low; on the average, it amounts to tenths of a percent of the residual formation.

With increase in load to the former value, additional subsidence of the soil takes place, the magnitude of which decreases in proportion to increase in compression pressure. A somewhat higher total deformation of the soil sample results than in a continuous increase in load. With repeated application of the load, additional soil subsidence decreases in proportion to the increase in the number of load cycles.

The small value of the recovery and additional subsidences in cyclic loading takes place with its first load and has a residual nature.

The carrying power of the lunar soil samples returned was determined by intrusion of

a die. The limiting size of the samples studied (with respect to the size of the die) allows consideration of the data obtained mainly as a qualitative characteristic of the die intrusion.

With intrusion into soil, which is in the maximally incoherent state, the die leaves a distinct impression, around which the soil surface is not deformed. The general nature of the deformation corresponds essentially to the process of local soil compaction. With increase in soil density, the resistance to intrusion of the die increases noticeably. The nature of the soil deformation also changes, a protrusion zone appears, and radial and concentric cracks appear around the die. Upon intrusion into highly compacted soil (weight by volume  $> 1.6 \text{ g/cm}^3$ ), the course of the

die subsidence curve changes and corresponds to deformation of the soil at the equilibrium maximum.

Values of the carrying power of the soil as a function of its weight by volume,  $\gamma$ , are presented in figure 7.

The carrying power was determined for the initial part of the intrusion curve, and it corresponds to the pressure on the die, at a subsidence equal to the diameter of the die.

A sharp increase in carrying power is observed, with increase in weight by volume above  $1.4$  to  $1.5 \text{ g/cm}^3$ .

The following characteristic sections can be distinguished in the "carrying power—weight by volume" curve. In regions of low soil compaction ( $\gamma < 1.4 \text{ g/cm}^3$ ), the main role in deformation of the soil is played by compressibility of the soil under the die. In strong compaction ( $\gamma > 1.6 \text{ g/cm}^3$ ), soil deformation takes place by means of general shear. At  $\gamma = 1.4\text{--}1.6 \text{ g/cm}^3$ , subsidence of the die is determined by compaction of the soil and local shears around the die.

Deformation of the lunar soil in shear tests is indicated in figure 8.

The shear stress reaches a maximum at a certain shear deformation value. A sharp

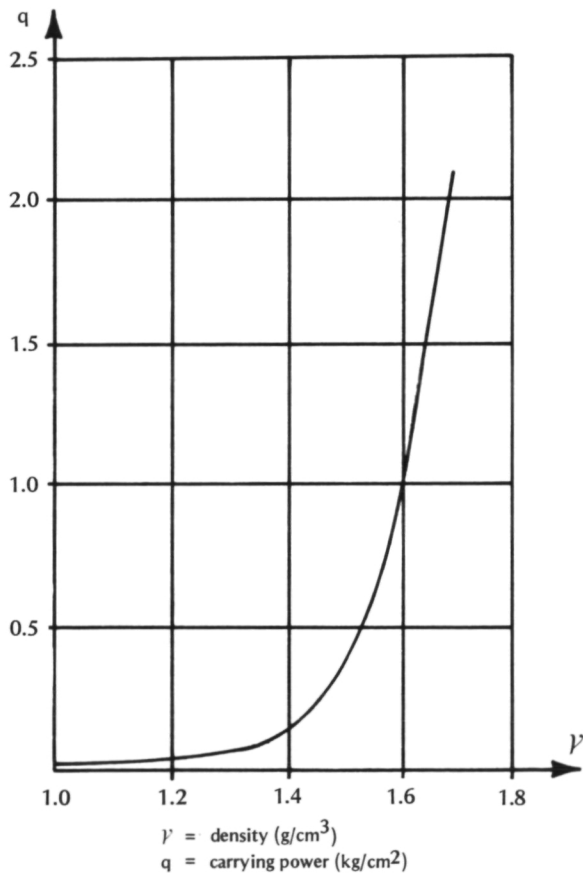

Figure 7.—Carrying power as a function of weight by volume.

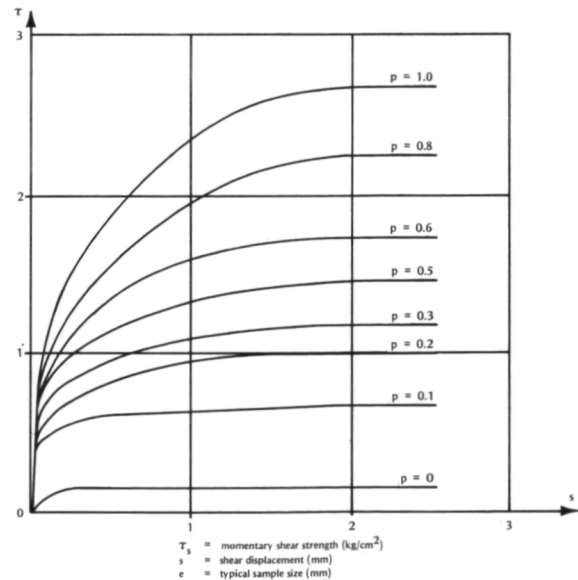

Figure 8.—Deformation of lunar soil in shear tests.

drop in the stress with increase in deformation does not occur, which is evidence of preservation of the relatively constant average value of the forces of adhesion in the soil. A decrease in shear stress is observed, only with a considerable increase in deformation, and is explained mainly by a decrease in cross section of the sample.

The increase in shear stress from displacement of the shear is approximated well by the exponential relationship

$$\tau_s = \varepsilon \times \left(\frac{s}{e}\right)^m \quad (17)$$

where  $\tau_s$  is the current shear strength (kg/cm<sup>2</sup>);  $\tau$  is the maximum shear strength (kg/cm<sup>2</sup>);  $s$  is the shear displacement (cm);  $e$  is the typical sample size; and  $m$  is an exponent.

## Mechanical Properties of Lunar Soil in its Natural State

The mechanical properties of soil on the lunar surface along the paths of Lunokhod 1 and Lunokhod 2 were determined on the basis of regular periodic measurements of the soil properties using a conical-lobe die (ref. 2). About 100 measurements were made in all, over a total path length of 47 km. The die penetrated into the soil up to 100 mm depth.

An averaged differential distribution curve of the carrying power of the soil along the courses is shown in figure 9. Experimental data on distribution of the mechanical properties of the lunar soil are quite well described by a shifter Rayleigh equation:

$$f(q) = 2\lambda \times (q - q_0) \times e^{-\lambda^2(q - q_0)^2} \quad (18)$$

where  $f(q)$  is the carrying power probability density;  $q$  is the value of the carrying power;  $q_0$  is the minimum value of the carrying power; and  $\lambda$  is the degree of nonuniformity of the soil properties.

The quantity  $q_0$  is determined to a considerable extent by the dimensions of the die and depth of penetration into the soil. With decrease in die dimensions,  $q_0$  also will decrease.

The parameters  $q_0$  and  $\lambda$  in equation (18) can be determined from the value of the

mathematical expectation and dispersion. The average values of these coefficients are  $q_0 = 0.08 - 0.1$  kg/cm<sup>2</sup> and  $\lambda = 3.0$  cm<sup>2</sup>/kg. The modal value of the carrying power was  $0.35 - 0.4$  kg/cm<sup>2</sup>.

The distribution of resistance to rotary shear is similar to the distribution of the carrying power. The modal value is  $0.045 - 0.055$  kg/cm<sup>2</sup>. A correlative dependence was developed between the carrying power ( $q$ ) and resistance to rotary shear ( $t$ ), of the type:

$$t = 0.029 - 0.2q$$

The correlation coefficient is 0.3, which indicates a relatively small functional interconnection of  $q$  and  $t$ . This can be explained by the fact that the carrying power is determined to a considerable extent by the internal angle of friction, which can change within broad limits for lunar soil, depending on the degree of compaction of the soil and the nature and magnitude of the external load.

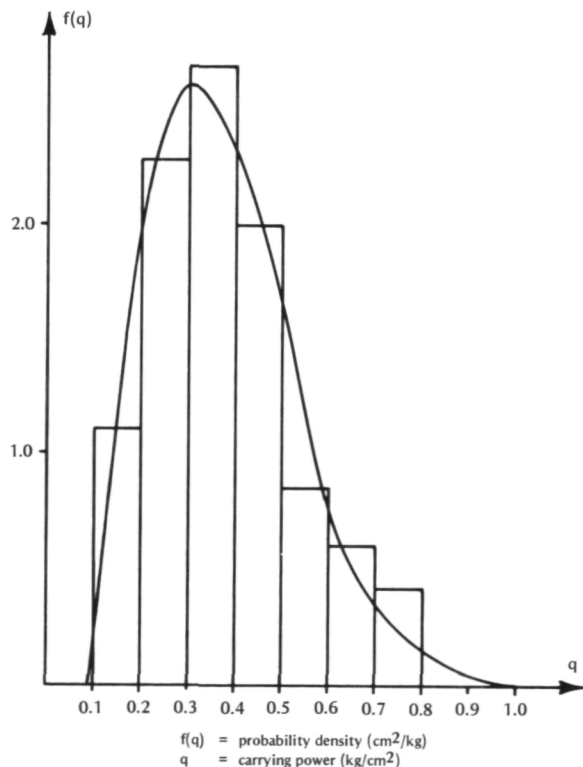

Figure 9.—Distribution of soil carrying power.



## Conclusion

Investigation of the processes of deformation and destruction of lunar soil has shown that its mechanical properties can change within broad limits, depending on the physical state of the soil. At the same time, not only the quantitative indicators change, but also the soil deformation mechanisms.

Soil in the maximally incoherent state has very low strength characteristics, and it has high compressibility. From the nature of the behavior of soil upon application of a load in this state, it approximates the properties of a compressed fluid, i.e., it has a small internal angle of friction, negligible adhesion, and a high coefficient of lateral pressure.

With compaction of the soil (a decrease in porosity), an increase in adhesion and internal angle of friction takes place, and the compressibility factor also decreases sharply.

With a porosity of 0.8 to 0.9, stabilization of the internal friction and compressibility parameters occurs. This is in good agreement with the fact that, if the soil compaction process is analyzed in the form of sums of two asymptotic processes, one of which determines the deformation of the soil by means of denser packing of the soil particles under the external pressure, the other characterizes the degree of destruction of the particles in their contact zones.

By the nature of the destruction, lunar soil with a porosity of 0.8 to 0.9 behaves like a solid, having considerable internal friction and appreciable bonding.

The mechanical properties of the lunar soil as it naturally occurs can change within considerable limits. However, the most likely (modal) value of the capacity is 0.35 to 0.4 kg/cm<sup>2</sup>. This is evidence of a considerable degree of compaction of the upper layers of the lunar soil as it occurs naturally. The degree of compaction of the soil was estimated from the correlative dependence between the porosity and carrying power, obtained on finely pulverized basalt, the particle size and

shapes of which were close to the average data on the lunar soil. A carrying power of 0.35 to 0.40 kg/cm<sup>2</sup> corresponds to a porosity of 0.9. This value is most likely for lunar soil as it occurs naturally.

Study of soil samples returned from various regions of the Moon as well as studies performed by Lunokhod 1 and Lunokhod 2, have shown that, despite significant differences in the geomorphological situation of the sections studied, the lunar soil obeys common regularities in the physical-mechanical characteristics. This allows one to assume the existence of a single mechanism of production and formation of the upper layer of the soil for a considerable part of the surface of the Moon.

Comparison of the data obtained with the results of study of the lunar soil in the Apollo and Surveyor programs has shown that significant differences are observed in a number of characteristics. Nevertheless, in terms of the physical indicators that have a definite effect on the mechanical characteristics, all samples studied are quite close together. The reason for the divergence apparently is a difference in methods of study. Therefore, to obtain comparable data, it is advisable to conduct studies of the soil by agreed upon methods, using standardized apparatus.

## References

1. GROMOV, V. V., A. K. LEONOVICH, A. D. DMITRIYEV et al., Mechanical Properties of Lunar Soil Samples Returned by the Luna 16 Automatic Station. *Kosmich. Issled.*, Vol. 9, No. 5, 1971.
2. LEONOVICH, A. K., V. V. GROMOV et al., Study of Physical-Mechanical Properties of a Lunar Soil Sample Returned by the Luna 20 Automatic Station and Along the Path of the Lunokhod 2 Self-Propelled Vehicle. *Report to the XXIV Congress IAF USSR, Baku, October 1973.*
3. ORNATSKAYA, N. V., *Soil Mechanics*, 1962.
4. LEONOVICH, A. K., V. V. GROMOV et al., Study of Mechanical Properties of Lunar Soil by the Lunokhod 1 Self-Propelled Vehicle. *Mobile Laboratory on the Moon: Lunokhod 1*, 1971.