

General Disclaimer

One or more of the Following Statements may affect this Document

- This document has been reproduced from the best copy furnished by the organizational source. It is being released in the interest of making available as much information as possible.
- This document may contain data, which exceeds the sheet parameters. It was furnished in this condition by the organizational source and is the best copy available.
- This document may contain tone-on-tone or color graphs, charts and/or pictures, which have been reproduced in black and white.
- This document is paginated as submitted by the original source.
- Portions of this document are not fully legible due to the historical nature of some of the material. However, it is the best reproduction available from the original submission.

(NASA-TM-73755) EXPERIMENTAL EVALUATION OF
PREMIXING-PREVAPORIZING FUEL INJECTION
CONCEPTS FOR A GAS TURBINE CATALYTIC
COMBUSTOR (NASA) 19 p HC A02/MF A01

N78-14313

Unclas
CSCL 20A G3/34 55253

EXPERIMENTAL EVALUATION OF PREMIXING - PREVAPORIZING FUEL INJECTION CONCEPTS FOR A GAS TURBINE CATALYTIC COMBUSTOR

Robert Tacina
National Aeronautics and Space Administration
Lewis Research Center
Cleveland, Ohio 44135

Work performed as part of a joint effort with
ENERGY RESEARCH AND DEVELOPMENT ADMINISTRATION
Division of Transportation Energy Conservation
Heat Engine Highway Vehicle Systems Program
Under Interagency Agreement EC-77-A-31-1011

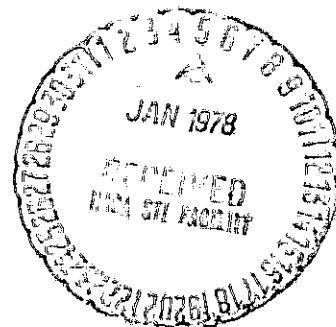

TECHNICAL PAPER to be presented at the
Winter Annual Meeting,
American Society of Mechanical Engineers
Atlanta, Georgia, November 27 - December 2, 1977

1. Report No NASA TM-73755	2. Government Accession No.	3. Recipient's Catalog No.	
4. Title and Subtitle EXPERIMENTAL EVALUATION OF PREMIXING- PREVAPORIZING FUEL INJECTION CONCEPTS FOR A GAS TURBINE CATALYTIC COMBUSTOR		5. Report Date August 1977	6. Performing Organization Code
		8. Performing Organization Report No E-9301	
7. Author(s) Robert Tacina		10. Work Unit No.	
9. Performing Organization Name and Address National Aeronautics and Space Administration Lewis Research Center Cleveland, Ohio 44135		11. Contract or Grant No.	
		13. Type of Report and Period Covered Technical Memorandum	
12. Sponsoring Agency Name and Address Energy Research and Development Administration Division of Transportation Energy Conservation Washington, D.C. 20545		14. Sponsoring Agency Code Report No. CONS/1011-19	
		15. Supplementary Notes This report was prepared under Interagency Agreement EC-77-A-31-1011.	
16. Abstract Experiments were performed to evolve and evaluate a premixing-prevaporizing fuel system to be used with a catalytic combustor for possible application in an automotive gas turbine. Spatial fuel distribution and degree of vaporization were measured using Jet A fuel. Three types of air-blast injectors, an air-assist nozzle and a simplex pressure atomizer were tested. Air swirlers with vane angles up to 30° were used to improve the spatial fuel distribution. The work was done in a 12-cm (4.75-in.) diameter tubular rig. Test conditions were: a pressure of 0.3 and 0.5 MPa (3 and 5 atm), inlet air temperatures up to 800 K (980° F), velocity of 20 m/sec (66 ft/sec) and fuel-air ratios of 0.01 and 0.025. Uniform spatial fuel distributions that were within ±10 percent of the mean were obtained. Complete vaporization of the fuel was achieved with airblast configurations at inlet air temperatures of 550 K (530° F) and higher. The total pressure loss was less than 0.5 percent for configurations without air swirlers and less than 1 percent for configurations with a 30° vane angle air swirler.			
17. Key Words (Suggested by Author(s)) Fuel injection systems Atomization Evaporation		18. Distribution Statement Unclassified - unlimited STAR Category 34 ERDA Category UC-96	
19. Security Classif. (of this report) Unclassified	20. Security Classif. (of this page) Unclassified	21. No. of Pages	22. Price*

EXPERIMENTAL EVALUATION OF PRE-MIXING-PREVAPORIZING FUEL INJECTION
CONCEPTS FOR A GAS TURBINE CATALYTIC COMBUSTOR

Robert Tacina
National Aeronautics and Space Administration
Lewis Research Center
Cleveland, Ohio 44135

ABSTRACT

Experiments were performed to evolve and evaluate a premixing-prevaporizing fuel system to be used with a catalytic combustor for possible application in an automotive gas turbine. Spatial fuel distribution and degree of vaporization were measured using Jet A fuel. Three types of airblast injectors, an air-assist nozzle and a simplex pressure atomizer were tested. Air swirlers with vane angles up to 30° were used to improve the spatial fuel distribution. The work was done in a 12-cm (4.75-in.) diameter tubular rig. Test conditions were: a pressure of 0.3 and 0.5 MPa (3 and 5 atm), inlet air temperatures up to 800 K (980° F), velocity of 20 m/sec (66 ft/sec) and fuel-air ratios of 0.01 and 0.025. Uniform spatial fuel distributions that were within ±10 percent of the mean were obtained. Complete vaporization of the fuel was achieved with airblast configurations at inlet air temperatures of 550 K (530° F) and higher. The total pressure loss was less than 0.5 percent for configurations without air swirlers and less than 1 percent for configurations with a 30° vane angle air swirler.

NOMENCLATURE

E	degree of vaporization = $\frac{(f/a)_v}{(f/a)_v + (f/a)_l}$
E/a	fuel-air ratio
(E/a) _{mean}	fuel-air ratio determined by inlet fuel flow divided by inlet airflow
P _{in}	inlet pressure
T _{in}	inlet air temperature
V	probe velocity at inlet
V _R	reference velocity, velocity based on inlet pressure, inlet temperature, and the area of the 12-cm (4.75-in.) diameter duct
w	fuel flow through probe
w _a	airflow through the probe at isokinetic velocity
w _a ¹	airflow through the probe

Subscripts:

iso	isokinetic
l	liquid
p	probe
v	vapor

INTRODUCTION

The use of combustors with lean premixed-prevaporized fuel-air mixtures has been shown to have the potential to keep NO_x levels low (1). Since NO_x is exponentially dependent on flame temperature, the use of a catalytic reaction has the potential to reduce NO_x levels even further by being able to completely react the fuel at temperatures below the flammability limit. Catalysis evaluation work being done at Lewis as described in references 2 to 4 has utilized vaporized propane. This paper describes the effort to develop a liquid fuel preparation system to be used with the catalytic combustor.¹ Uniform fuel distribution and complete vaporization are necessary for catalytic combustors since the substrates are currently limited to temperatures below 1800 K (2780° F), thus rich zones or liquid drops burning off the substrate could damage it. The development of such a fuel system would also have application to premixed-prevaporized combustors using homogeneous combustion.

Data on drop size from various types of fuel injectors and data on single droplet vaporization rates are plentiful. But only limited data has been published on spatial fuel distribution and vaporization rates of sprays. Such information is necessary for the development of a premixing-prevaporizing system for a gas turbine combustor. Using a multiple-orifice contrastream injector, vaporization rates of JP-5 sprays were measured in reference 5 and using a simple orifice contrastream injector, vaporization rates of isooctane sprays were measured in reference 6. In reference 7 the spatial fuel distribution and degree of vaporization were measured from simplex pressure atomizers using isooctane and No. 2 fuel oil as the fuel.

In this study spatial fuel distribution and vaporization data were taken with two types of airblast injectors, a simplex pressure atomizer and a

¹Work sponsored by Division of Transportation Energy Conservation, ERDA.

Sonicore fuel injector. Air swirlers with vane angles up to 30° were used to improve the spatial fuel distribution. Test conditions were: inlet air pressure, 0.3 and 0.5 MPa (3 and 5 atm); reference velocity, 20 m/sec (66 ft/sec); fuel-air ratios of 0.01 and 0.025; and air inlet temperatures from 450 K (350° F) to 800 K (980° F). The fuel was Jet A.

APPARATUS AND PROCEDURE

Test Rig

Figure 1 is a schematic of the test rig. The airflow rate was measured with a square-edged orifice. The air was heated up to 800 K (980° F) in a nonvibrating preheater. The fuel flow was measured by two turbine flowmeters in series. A temperature and pressure measurement was taken upstream of the fuel injector. The duct diameter was 10.2 cm (4.0 in.) upstream of the injector and 12 cm (4.75 in.) downstream. A 7.6-cm (3.0-in.) diameter inlet section was inserted upstream of the injector to increase the air velocity which improves fuel atomization. A diffuser was then inserted downstream of the injector.

Two sample collecting probes, 90° apart, were located 35.6 cm (14.0 in.) downstream of the fuel injector to sample the fuel-air mixture. The fuel-air ratio was determined by passing the mixture sample over a catalyst heated in an oven to 1030 K (1400° F) and then analyzing the products of combustion for carbon monoxide, carbon dioxide and unburned hydrocarbons. Carbon monoxide and carbon dioxide concentrations were measured on Beckman nondispersive infrared analyzers and unburned hydrocarbon concentrations were measured on a Beckman Flame Ionization Detector. The amount of unburned hydrocarbons and carbon monoxide measured was negligible because mixture ratios were always very lean. A temperature and pressure measurement was also taken at the 35.6-cm (14.0-in.) downstream station. The fuel-air mixture was enriched with hydrogen and burned downstream of the sampling probes. Water was injected to cool the exhaust products and a back pressure valve was used to control the rig pressure.

Injectors

Five fuel injectors were evaluated. They were a multiple-jet contrastream injector, a multiple-jet cross-stream injector, a splash-groove injector, a simplex pressure atomizer, and an air-assist atomizer. The first three types of injectors are airblast atomizers; that is, they rely on the relative velocity between fuel and air for atomization. The simplex pressure atomizer relies on fuel pressure for atomization. The air assist was a Hartman whistle-type that depends on a high velocity external airstream for atomization.

Multiple-jet injector. Two multiple-jet injectors are shown in Figures 2 and 3. Figure 2 shows an injector where the fuel was injected contrastream from eight orifices. The diameter of the orifices was 0.25 mm (0.010 in.) in diameter and the radial location could be varied. The multiple-jet cross-stream injector is shown in Figure 3. Twenty-eight orifices of 0.37 mm (0.015 in.) diameter were located so that each of the 28 orifices injects fuel into a space of approximately equal area. Larger diameters were used since the penetration was not important and the 0.25-mm (0.010-in.) diameter orifices would plug due to carbon buildup.

Splash-groove fuel injector. This injector was developed by Ingebo (8) and is shown in figure 4. A sketch showing the principal features of the injector is shown in figure 4(a). Fuel is injected through orifices into three grooved portions of the nozzle. The fuel splashes over the lips of each of the three grooves and is atomized by the airflow. Configurations used with the splash-groove injector consisted of 10.2 cm (4 in.) (fig. 4(b)) and 7.6 cm (3 in.) (fig. 4(c)) inlets, and the use of air swirlers (fig. 4(d)).

Simplex pressure atomizer. The simplex nozzle used was a Monarch 0.013 m³/hr (3.5 gal/hr), hollow cone spray, with a 70° cone angle. Configurations tested consisted of 10.2 cm (4 in.) inlet (fig. 5(a)), 7.6 cm (3 in.) inlet (fig. 5(b)), insertion of air swirlers upstream (fig. 5(c)) and spraying the fuel contrastream (fig. 5(d)) as compared to the previous configurations in which the fuel was sprayed downstream. The air swirler was located upstream of the nozzle so that when the fuel was sprayed downstream there would not be liquid fuel impinging on the swirler.

Sonicore nozzle. The air-assist nozzle was a Hartman whistle-type that is produced commercially by Sonic Development Corporation. The particular nozzle used was a Sonicore P/N 125 M-A. This nozzle (see fig. 6) uses an external air supply which provides a high velocity airstream for atomizing. As the airstream impinges upon the resonator cup, it produces strong local shock waves in the space between the nozzle and cap. Fuel is pumped or sucked into the airstream and the result is a cone-shaped spray pattern of finely atomized droplets. The external airstream had a supply pressure of 0.55 MPa (5.5 atm). Configurations tested consisted of a 7.6-cm (3.0-in.) inlet with and without the use of air swirlers.

Data Analysis

The sample collecting probes were used to determine the spatial fuel distribution and the degree of vaporization.

Spatial fuel distribution. The spatial fuel distribution was found by traversing the sample probe across the diameter of the duct. The fuel-air ratio was sampled isokinetically (at seven points) across the diameter of the duct with each probe. The fuel-air ratio in the plot is normalized using the fuel-air ratio determined from the inlet fuel flow divided by the inlet airflow.

Vaporization data. The degree of vaporization was determined by the spillover technique (5). This technique consists of varying the velocity through the probe above and below the isokinetic velocity and determining the degree of vaporization by the change in fuel-air ratio through the probe. The following analysis was used (see NOMENCLATURE):

$$\left(\frac{f}{a}\right)_p = \left(\frac{f}{a}\right)_i + \left(\frac{f}{a}\right)_v = \frac{w_f}{w_a} + \frac{w_v}{w_a} = \frac{w_f}{w_a} + \frac{w_v}{w_a} + \frac{w_v}{w_a} \quad (1)$$

If the degree of vaporization is uniform in the vicinity of the probe, then the vapor fuel-air ratio through the probe does not vary with velocity through the probe; that is

$$\frac{w_v}{w_a} = \text{constant} = \left(\frac{f}{a}\right)_{iso} \cdot E \quad (2)$$

w_p is assumed to be constant; that is, the streamlines of the liquid drops do not change with velocity through the probe

$$\frac{w_p}{w_a} = \left(\frac{l}{a}\right)_{l, iso} = (1 - E) \left(\frac{l}{a}\right)_{iso} = \text{constant} \quad (3)$$

$$\left(\frac{l}{a}\right)_p = (1 - E) \left(\frac{l}{a}\right)_{iso} \left(\frac{w_a}{w_p}\right) + E \left(\frac{l}{a}\right)_{iso} \quad (4)$$

In terms of velocity

$$\frac{w_a}{w_p} = \frac{V_{iso}}{V_p}, \quad V_{iso} = V_R \quad (5)$$

$$\frac{(l/a)_p}{(l/a)_{iso}} = (1 - E) \left(\frac{V_{iso}}{V_p}\right) + E \quad (6)$$

The fuel-air ratio through the probe was normalized by the fuel-air ratio determined by the inlet fuel flow divided by the inlet airflow.

$$\frac{(f/a)_p / (f/a)_{\text{mean}}}{(f/a)_{iso} / (f/a)_{\text{mean}}} = (1 - E) \left(\frac{V_{iso}}{V_p}\right) + E \quad (7)$$

$$E = \left[\frac{(f/a)_p / (f/a)_{\text{mean}}}{(f/a)_{iso} / (f/a)_{\text{mean}}} - \frac{V_{iso}}{V_p} \right] \left/ \left(1 - \frac{V_{iso}}{V_p} \right) \right. \quad (8)$$

Figure 7 is a typical plot. The degree of vaporization is 0.84; that is, 84 percent of the fuel has vaporized.

RESULTS AND DISCUSSION

The spatial fuel distribution, degree of vaporization, and pressure drop data will be discussed for the injector configurations tested. Data was taken at the following test conditions: inlet air temperature, 600 K (620° F), inlet air pressure, 0.3 and 0.5 MPa (3 and 5 atm); reference velocity, 20 m/sec (66 ft/sec); and fuel-air ratios of 0.010 and 0.025. If a satisfactory spatial fuel distribution was obtained, the inlet temperature was raised to 800 K (980° F) (facility maximum) with the other conditions the same. Lower inlet temperatures were used to obtain vaporization data.

Spatial Fuel Distribution

Multiple-jet injectors. The spatial fuel distribution obtained with the multiple-jet counterstream fuel injector (Fig. 2) is shown in figure 8. With the radial injection 1.9 cm from the wall (68 percent of the radius) the profile was center peaked. Moving the radial injection point to 1.3 cm from wall (78 percent of the radius) improved the distribution significantly. Decreasing the distance from the wall to 0.95 cm (84 percent of the radius) only slightly improved the distribution. At the radial injection distance of 1.3 and 0.95 cm the fuel distribution is within ± 20 percent of the average.

In figure 9 the spatial fuel distribution obtained with the multiple-jet cross-stream fuel injector (Fig. 3) is presented. Nearly uniform distribution was obtained, local values of fuel-air ratio were within ± 10 percent of the average value.

The mixing length was reduced from 39.4 cm (15.5 in.) to 25 cm (9.9 in.) and the fuel distribution obtained is plotted in figure 9(b). The distribution was not as uniform as that obtained using the longer length but still within ± 15 percent of the average.

Splash-groove fuel injector. The spatial fuel distribution for the splash-groove fuel injector is shown in figure 10. The profile obtained using the 12-cm (4.75-in.) inlet diameter was very fuel rich in the center. Reducing the inlet diameter to 7.6 cm (3.0 in.) improved the profile significantly. The profile became nearly uniform, within ± 10 percent, when a 15° vane angle air swirler was added. Increasing the vane angle to 30° also resulted in fuel-air distributions within ± 10 percent of the average value (see fig. 10(b)).

Simplex pressure atomizer. The spatial fuel distribution for the simplex pressure atomizer is shown in figure 11. The penetration of the fuel into the airstream was small since the fuel distribution was center peaked at the conditions tested and when an air swirler was not used. In contrast with the splash-groove results, the distribution was approximately the same with a 10.2 cm (4.0 in.) and 7.6 cm (3.0 in.) inlet. At the lower inlet air temperature of 450 K (350° F), the penetration was even less. The increase in air density with temperature seems to have a greater effect on penetration than the increased pressure drop across the nozzle (fuel pressure drop increases because the airflow has to increase to maintain the same velocity at the lower inlet air temperature and thus fuel flow has to increase to maintain the same fuel-air ratio).

Adding a 30° vane angle air swirler resulted in a more uniform profile (see fig. 11(a)). The distribution was within ± 15 percent of the average except there remained one quadrant in which the fuel-air ratio was high at the wall. This effect was more pronounced when a 15° vane angle air swirler was used. As the swirler was rotated the location of this rich zone would rotate. Only the fuel tube was unisymmetrical and there may have been some interaction between the swirler and fuel tube.

Spraying the fuel upstream or counterstream the profile was nearly uniform (within ± 10 percent of the average) using a swirler with 30° vane angles (see fig. 11(b)). The profile was still center peaked with the use of a 10° vane angle air swirler. The rich zone which was present when the fuel was sprayed counterstream was not present with upstream injection.

Sonicare fuel injector. The Sonicare fuel injector also had a center peaked fuel profile (see fig. 12) with the configuration (fig. 6) tested without an air swirler. With the addition of a 9° vane angle air swirler, the profile improved but was not symmetrical. Since the only thing that was not symmetrical was the fuel tube and air-assist tube, there must have been interaction between the tubes and the swirler. The profile improved when the swirler blade angle was increased to 12° and the fuel-air distribution was within ± 10 percent of the average when a 30° vane angle air swirler was used.

The mixing length was decreased from 35.6 cm (14.0 in.) to 24 cm (9.5 in.) and the results are presented in figure 12(b). The fuel-air distribution was within ± 15 percent of the average with a 24-cm mixing length.

Vaporization Data

The degree of vaporization was determined with the spill-over technique. The measurements were taken in the center of the duct and the injectors were tested without air swirlers.

The degree of vaporization as a function of inlet air temperature is shown in Figure 13 for the multiple-jet cross-stream injector, the splash-groove injector, the Sonicore nozzle, and the simplex nozzle. The multiple-jet cross-stream and splash-groove injectors gave the highest percent vaporized fuel, followed by the Sonicore and then the simplex nozzle. At an inlet air temperature of 500 K (440° F) the percent of fuel vaporized was 95 for the multiple-jet cross-stream injector, 94 for the splash-groove, 87 for the Sonicore, and 61 for the simplex nozzle.

Calculation of the mean drop size for the various injectors should indicate the relative rates of fuel vaporization. Drop size calculations were made for the following inlet conditions: reference velocity of 20 m/sec (66 ft/sec), pressure of 0.5 MPa (5 atm), inlet air temperature of 500 K (440° F), and fuel-air ratio of 0.01. For the airblast injectors (multiple-jet cross-stream and splash-groove) the Sauter mean drop size was calculated using the correlations of Nukiyama-Tanigawa (as given in ref. 9) to be 69 μ m and from Lorenzetti and Lefebvre (10) to be 71 μ m. For the simplex pressure atomizer the Sauter mean drop size was calculated to be between 60 and 100 μ m using the correlations given in reference 10. Using the correlation given in reference 11 for a simplex pressure atomizer the Sauter mean drop size came out to be 74 μ m. Data from the manufacturer indicates the drop size of the Sonicore nozzle to be less than 20 μ m.

The vaporization data, however, implies that the airblast configurations had the smallest initial drop sizes. A possible explanation is that the correlations for the airblast injectors were developed for atmospheric air pressure and at 0.5 MPa (5 atm) the drop size may be much smaller. The drop sizes of the Sonicore nozzle may have been smaller than the airblast injectors and still had lower vaporization rates. This is because the air for the air-assist was at ambient conditions and thus the drops were initially surrounded by air at a much lower temperature.

Vaporization data was taken at pressure levels of 0.3 and 0.5 MPa (3 and 5 atm). In Figure 14 the degree of vaporization using the multiple-jet cross-stream injector is plotted against inlet air temperature for the two pressures. The vaporization rates are higher at the higher pressure. At an inlet air temperature of 450 K there was about 7 percent more fuel vaporized at the higher pressure. Evidently, at these conditions, the effect of higher heat transfer rates at the higher pressure is greater than the higher partial pressures needed for vaporization.

Pressure Drop

At a reference velocity of 20 m/sec, an inlet air temperature of 600 to 800 K and an inlet pressure of 0.5 MPa (5 atm), the pressure drop from the injector to the sample probes was less than 0.5 percent of the inlet total pressure for the injectors tested without swirlers. With a 30° air swirler the pres-

sure drop was approximately 1 percent. For an automotive application it is desired to keep the combustor total pressure loss below 1 percent. A 2 percent pressure loss for the catalytic section seems impractical (3), so a 1 percent pressure drop for the fuel injector would be acceptable.

CONCLUDING REMARKS

Uniform spatial fuel distribution and a high degree of vaporization with acceptable total pressure loss were obtained at the conditions tested. At an air inlet temperature of 800 K, cool flame reactions were observed. Advanced automotive gas turbine cycles call for much higher combustor inlet temperatures and thus dwell time may have to be reduced to prevent autoignition of the fuel. For a catalytic combustor uniform velocity profiles would also be necessary. Velocity measurements were not made in this study. Nonuniform velocity profiles would be very likely to occur with configurations using air swirlers, especially as the vaporizer length is shortened.

Summary of Results

Several fuel injectors were tested for spatial fuel-air distribution, degree of fuel vaporized, and total pressure drop. The multiple-jet cross-stream fuel injector with 28 distributed fuel injection locations and a mixing length of 39.4 cm (15.5 in.) gave the best results. Fuel-air spatial distributions that were within ± 10 percent of the mean were obtained, 100 percent of the fuel was vaporized at an inlet air temperature of 600 K (620° F), and the pressure was less than 0.5 percent. A multiple-jet counterstream fuel injector with eight fuel injection locations and a mixer length of 39.4 cm (15.5 in.) had spatial fuel-air distributions within ± 20 percent of the mean.

With the splash-groove, Sonicore and simplex fuel injectors the fuel was injected from the center of the duct and center peaked profiles were obtained. The use of air swirlers improved the mixing so that fuel-air spatial distributions that were within ± 10 percent of the mean were obtained. The mixer lengths were 33 cm (13.0 in.) for the splash-groove, 34.8 cm (14.0 in.) for the Sonicore and 33.7 cm (13.2 in.) for the simplex. The use of air swirlers is not desired for a catalytic combustor, however, since non-uniform velocity profiles result, especially as the mixer length is decreased. The use of a 30° vane angle air swirler also increased the pressure drop from 0.5 to 1.0 percent. Of these injectors the splash-groove gave the best vaporization results (100 percent of the fuel vaporized at an inlet air temperature of 600 K (620° F)) and the simplex the poorest (80 percent at 600 K). The Sonicore vaporization results (96 percent at 600 K) would have been better if the air for the air-assist would have been preheated rather than at ambient temperature.

REFERENCES

- 1 Anderson, D. N., "Effect of Premixing on Nitric Oxide Formation," NASA TM X-68220, 1973.
- 2 Anderson, D. N., "Preliminary Results from Screening Tests of Commercial Catalysts with Potential Use in Gas Turbine Combustors. Part 1. Furnace Studies of Catalyst Activity," NASA TM X-71410, 1976.
- Anderson, D. N., "Preliminary Results from

Screening Tests of Commercial Catalysts with Potential Use in Gas Turbine Combustors. Part II. Combustion Test Rig Evaluation," NASA TM X-73412, 1976.

3 Anderson, D. N., "Emissions and Performance of Catalysts for Gas Turbine Catalytic Combustors," NASA TM X-73543, 1977.

4 Anderson, D. N., Tacina, R. R., and Mroz, T. S., "Catalytic Combustion for the Automotive Gas Turbine," NASA TM X-73589, 1977.

5 Foster, H. H. and Ingebo, R. D., "Evaporation of JP-5 Fuel Sprays in Air Streams," NACA RM55SR02, 1956.

6 Bahr, D. W., "Evaporation and Spreading of Isooctane Sprays in High-Velocity Air Streams," NASA RM53114, 1953.

7 Kennedy, J. B. and McVey, J. B., "An Experimental Study of Fuel Spray Vaporization Rates," in API The 11th JANNAF Combustion Meeting, Vol. 2, United Research Labs., East Hartford, Ct., pp. 387-406.

8 Ingebo, R. D. and Norgren, C. T., "Combustor Exhaust Emissions with Air Atomizing Splash-Groove Fuel Injectors Burning JET A and Diesel Number 2 Fuels," NASA TM X-3255, 1975.

9 Barnett, H. C. and Hibbard, R. E., "Basic Considerations in the Combustion of Hydrocarbon Fuels with Air," NACA Rept. 1300, 1957.

10 Lorenzetto, G. E. and Lefebvre, A. H., "Measurements of Drop Size on a Plain-Jet Airblast Atomizer," AIAA Paper No. 76-679, Palo Alto, Calif., 1976.

11 "Summarizing Combustion System Development Contaminated Fuel Program," GT-7756-R, AirResearch Mfg. Co., Phoenix, Ariz., June 1966.

**ORIGINAL PAGE IS
OF POOR QUALITY**

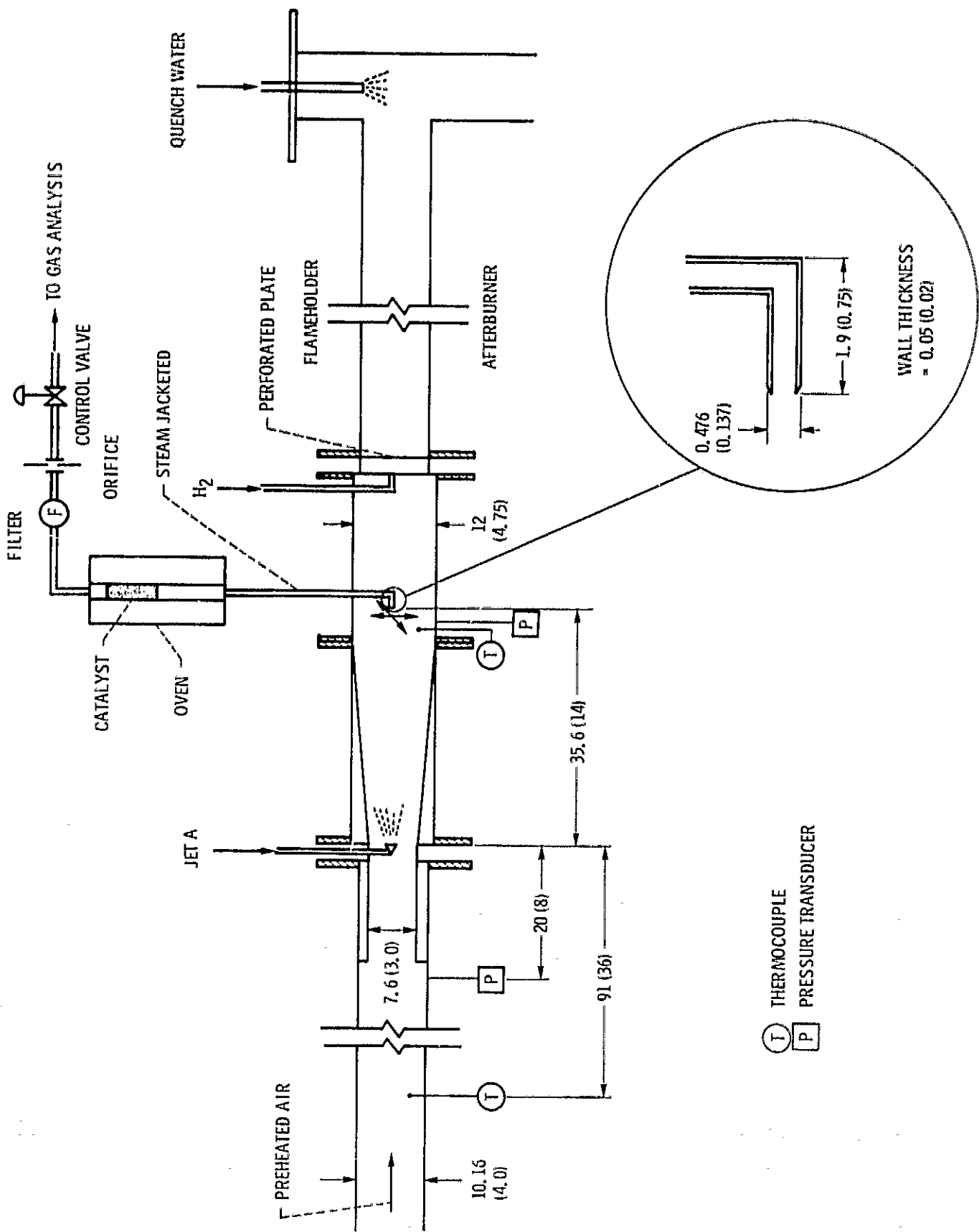

Figure 1 - Rig schematic. (Dimensions in cm (in.))

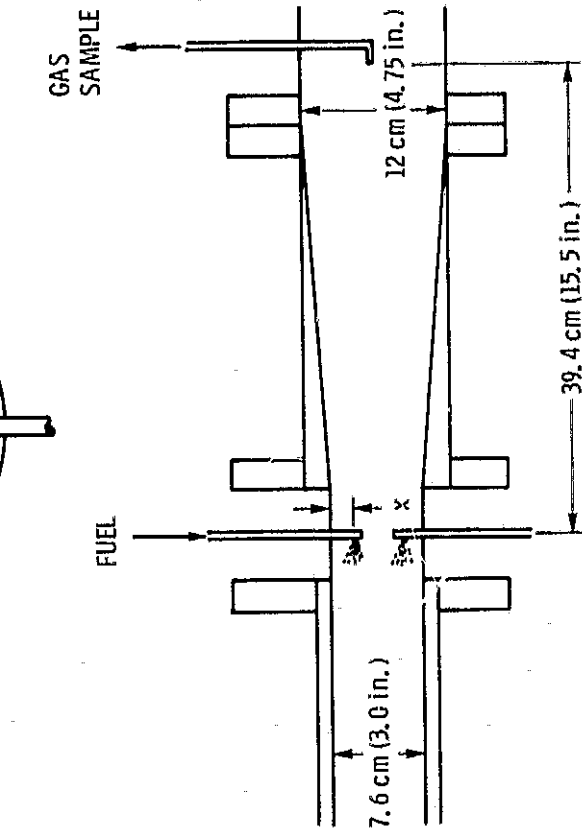
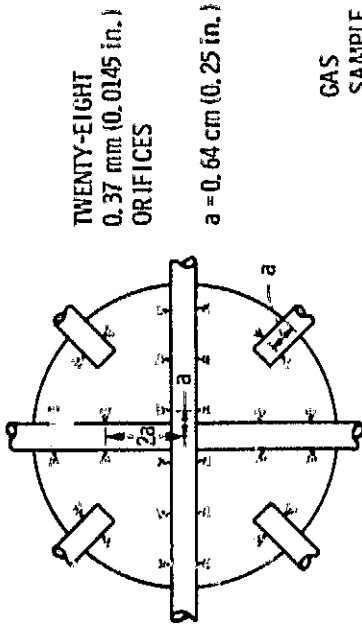
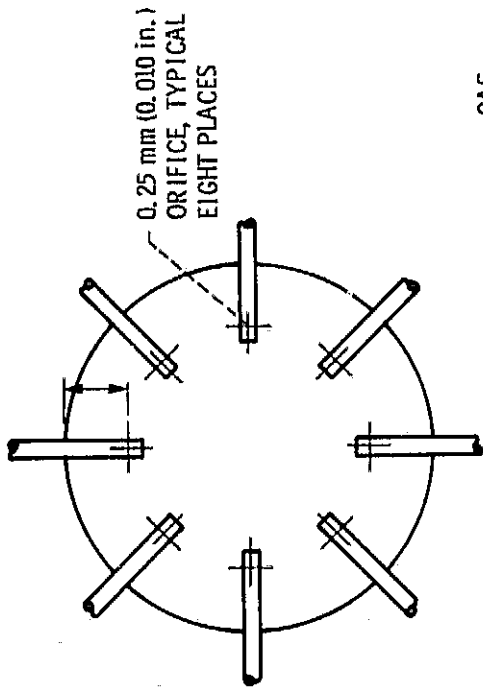

Figure 2 - Multiple-jet contra-stream fuel injector.

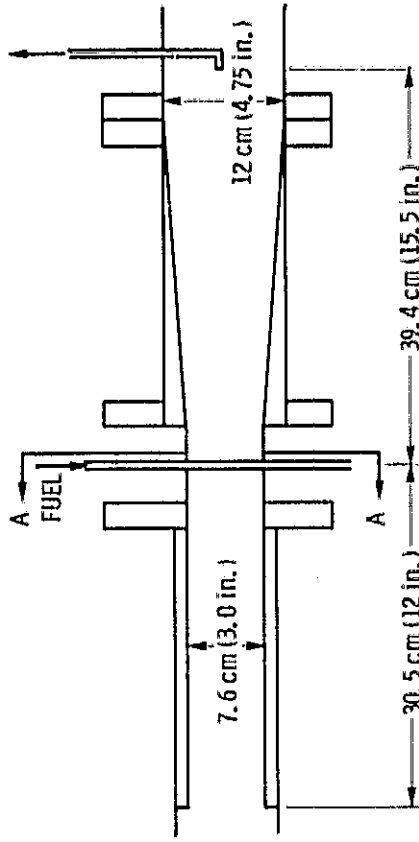
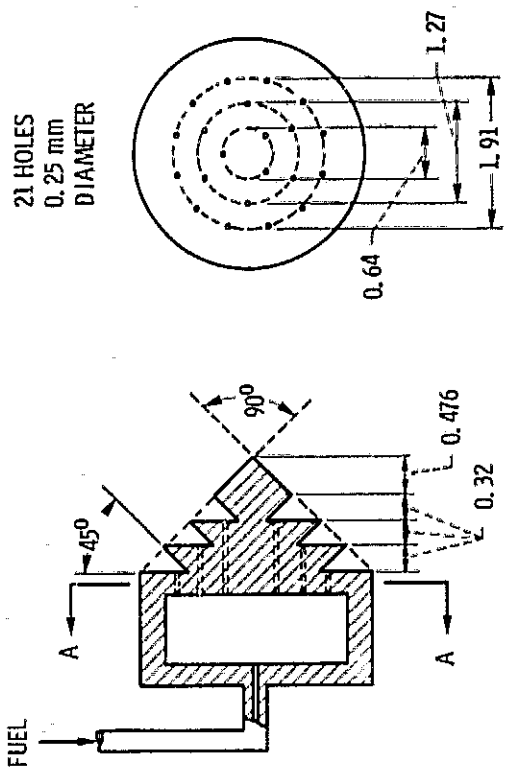
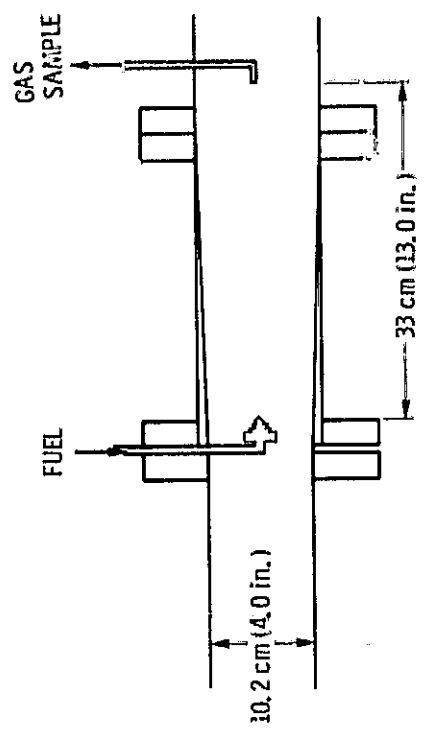

Figure 3 - Multiple-jet cross-stream injector, twenty-eight 0.37 mm (0.014 in.) holes, 7.6 cm (3.0 in.) inlet.



SECTION AA

(a) SPLASH-GROOVE INJECTOR.



(b) 10.2 cm (4.0 in.) INLET.

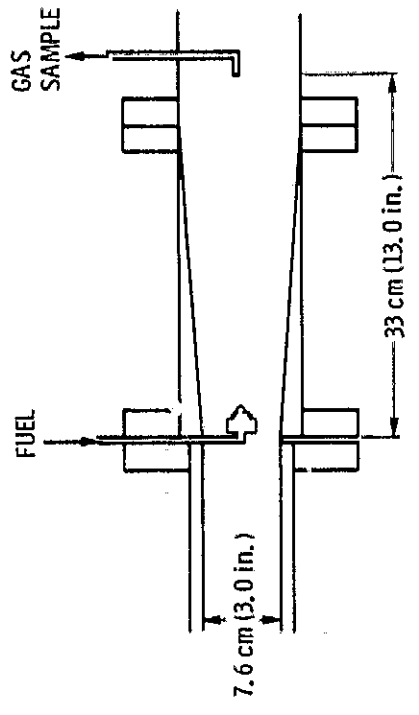
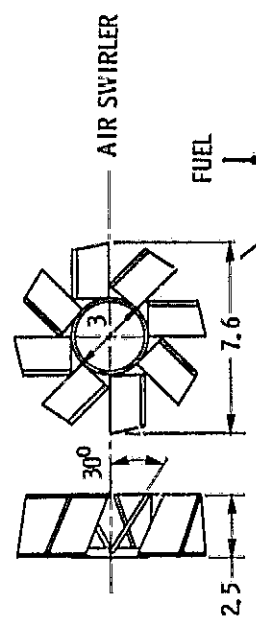

(c) 7.6 cm (3.0 in.) INLET.

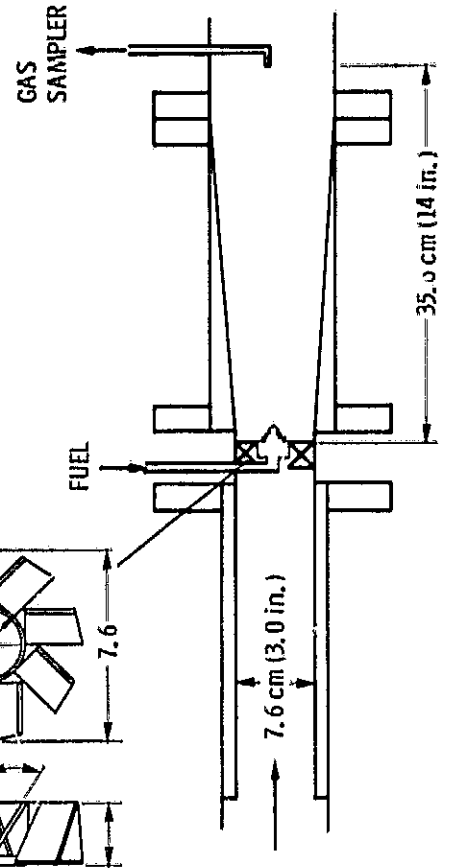

(d) 7.6 cm (3.0 in.) INLET, AIR SWIRLER.

Figure 4. - Splash-groove fuel injector.

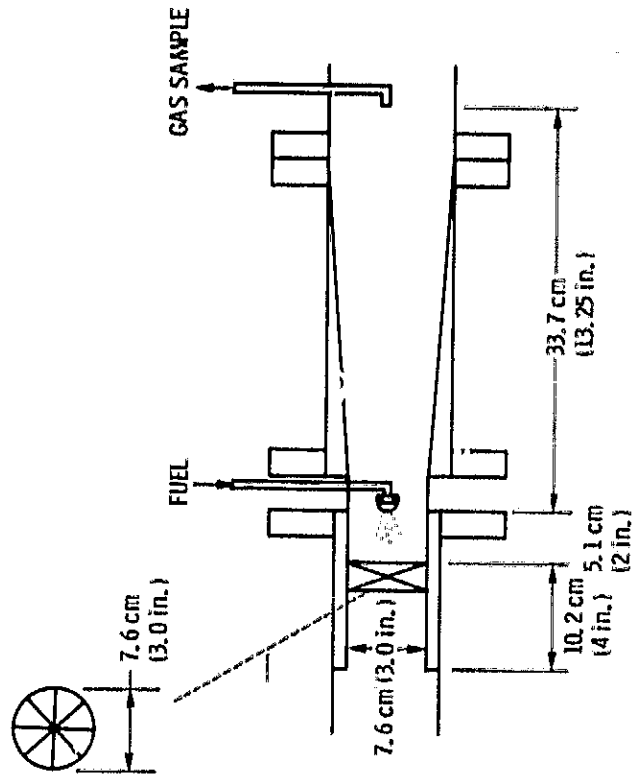
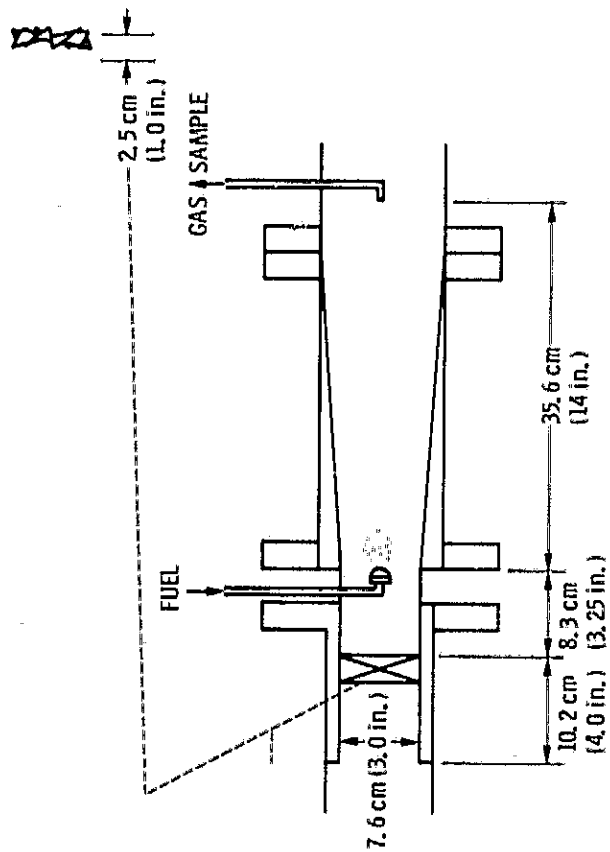
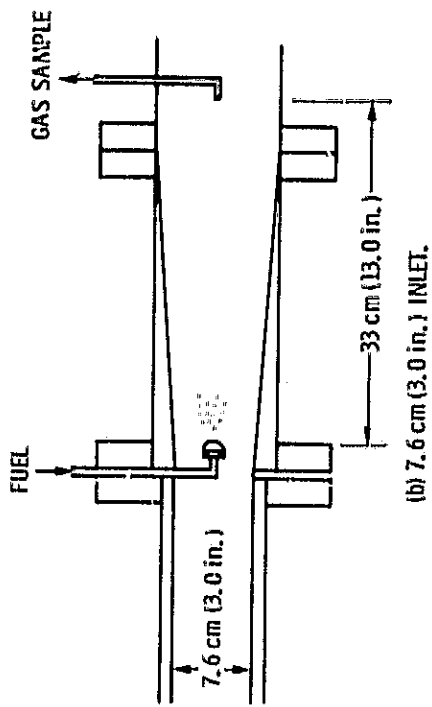
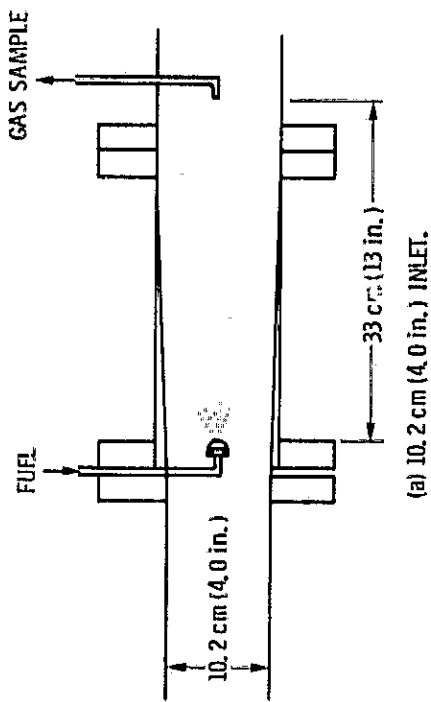

Figure 5. - Simplex pressure atomizer configurations.

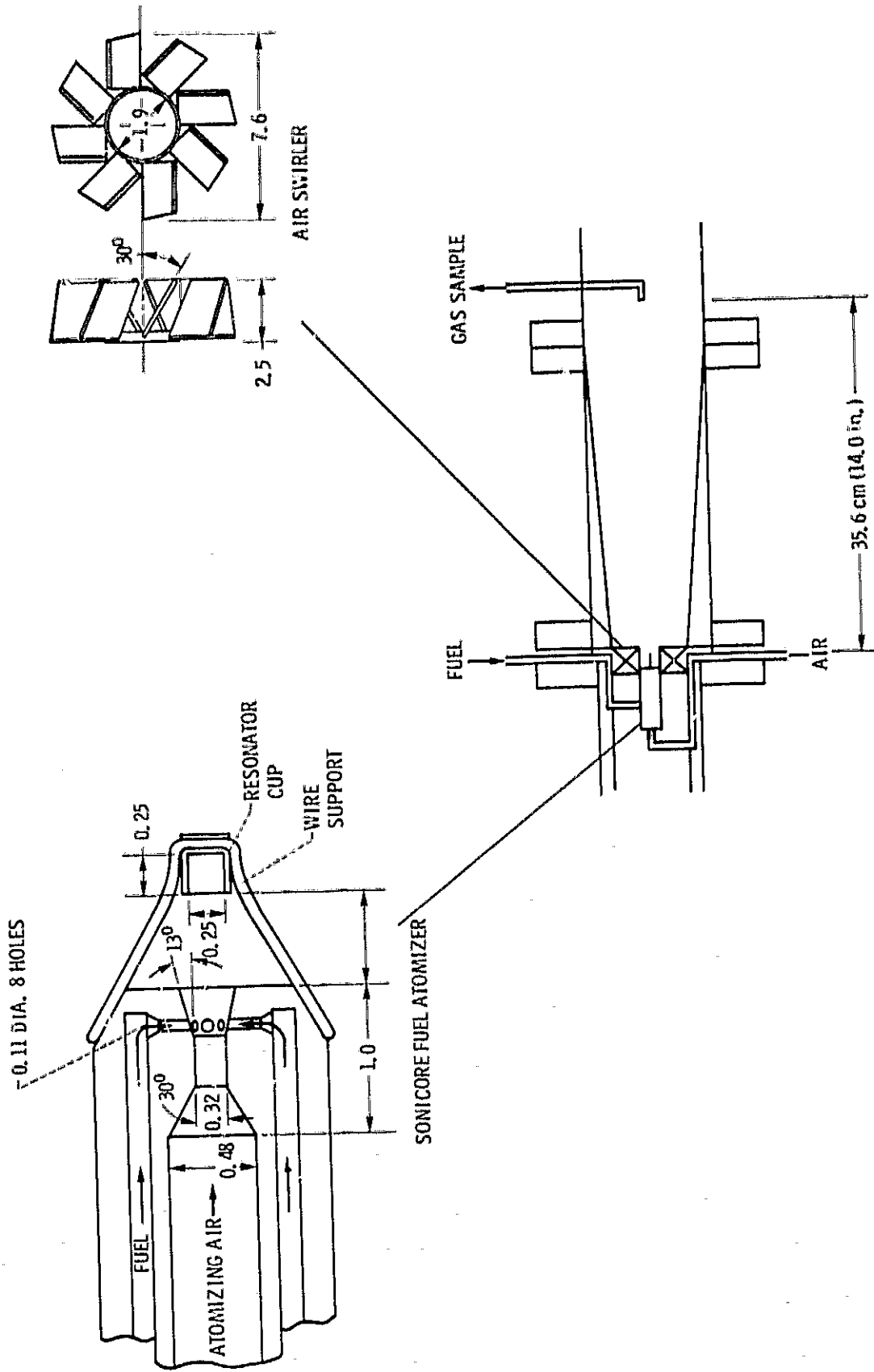

Figure 6. - Sonicore fuel atomizer and assembly.

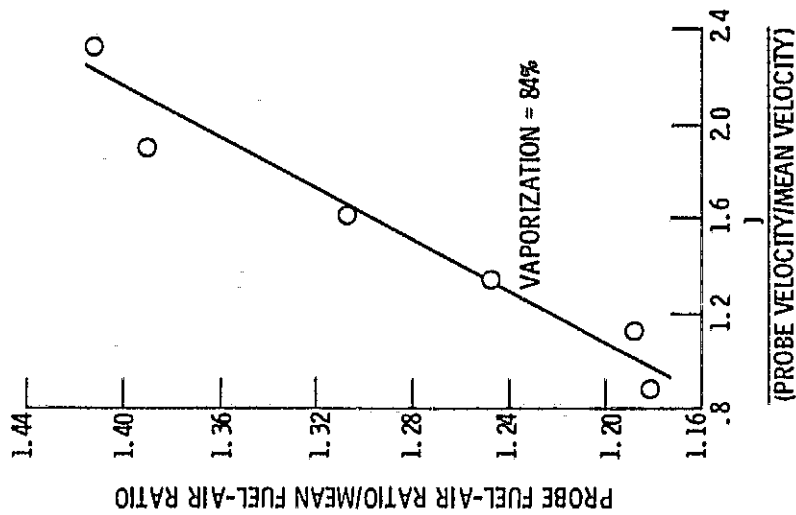

Figure 7. - Typical plot used to obtain degree of vaporization. Multiple-jet cross-stream injector, 29.5 cm vaporization length, $T_{in} = 444$ K (339° F), $V_p = 20$ m/s (66 ft/s), $P_{in} = 0.5$ MPa (5 atm), $f/a_{mean} = 0.010$.

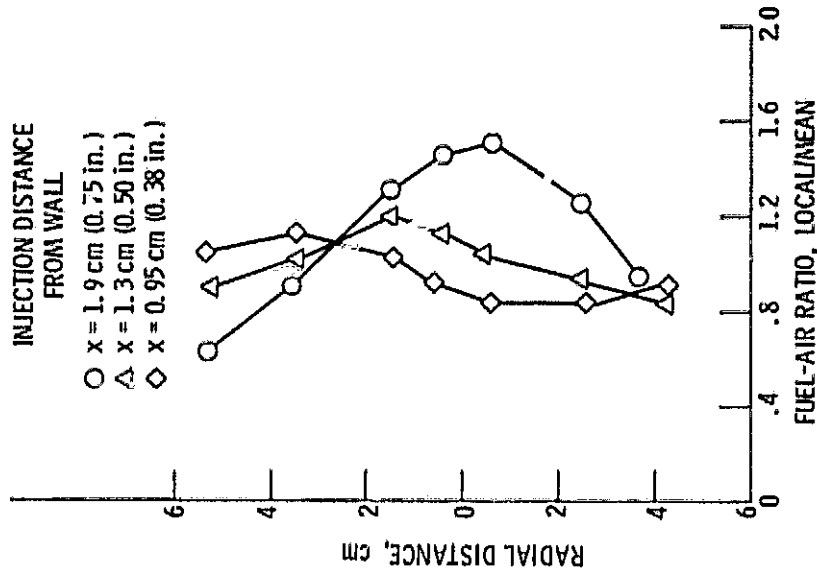

Figure 8. - Spatial fuel distribution, multiple-jet cross-stream fuel injector (see fig. 2). $T_3 = 600$ K (620° F), $V_R = 20$ m/s (66 ft/s), $P_3 = 0.5$ MPa (5 atm), $f/a = 0.010$.

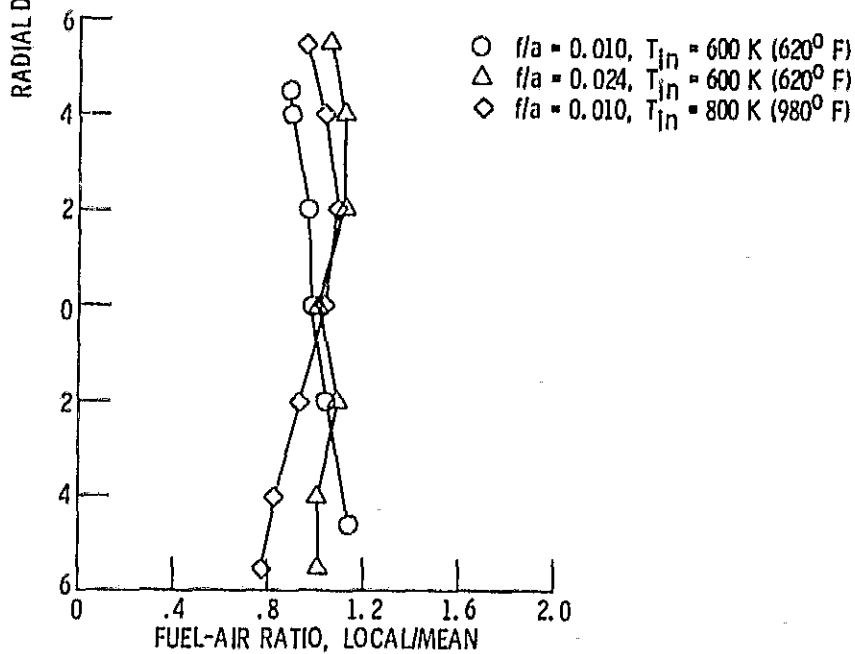
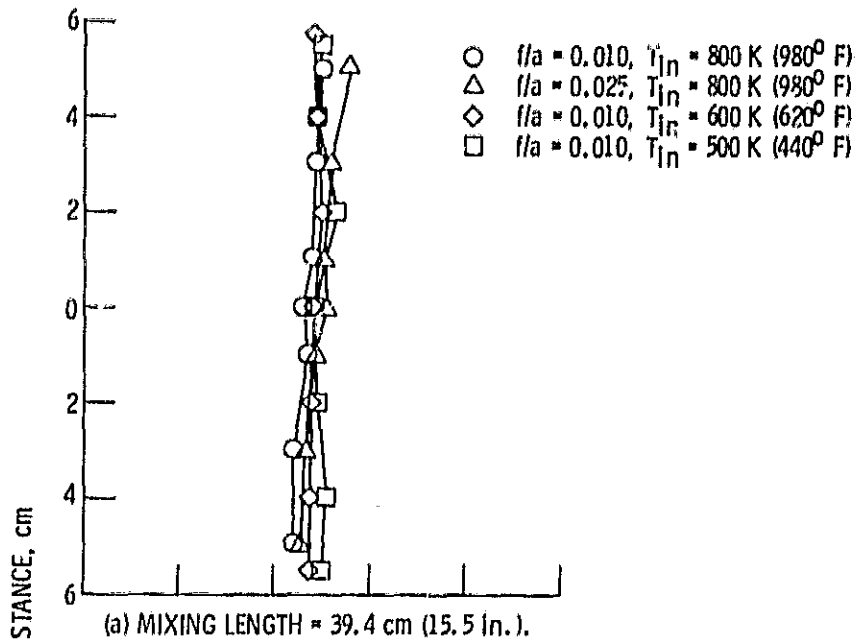

Figure 9. - Spatial fuel distribution, multiple-jet cross-stream injector
(see fig. 3). $V_R = 20$ m/s (66 ft/s), $P_{In} = 0.5$ MPa (5 atm).

E-9301

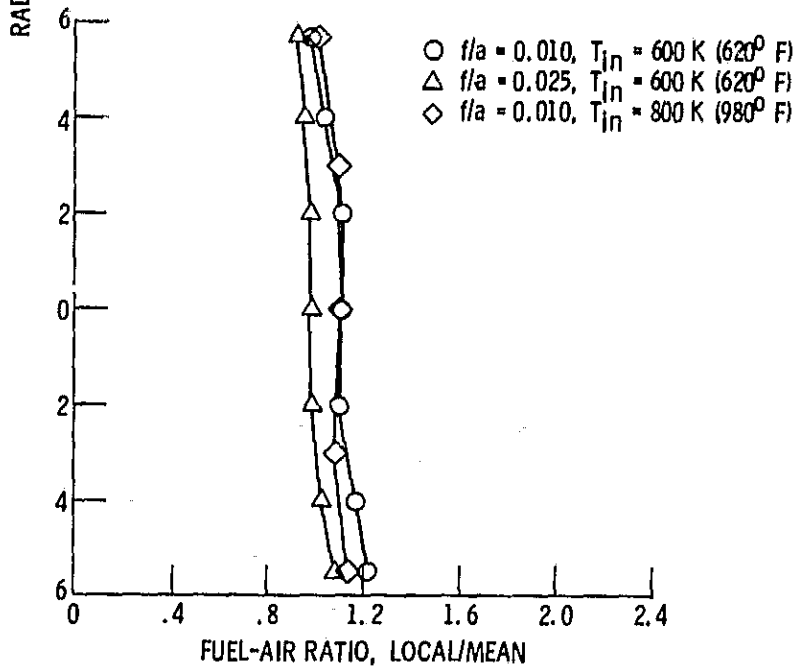
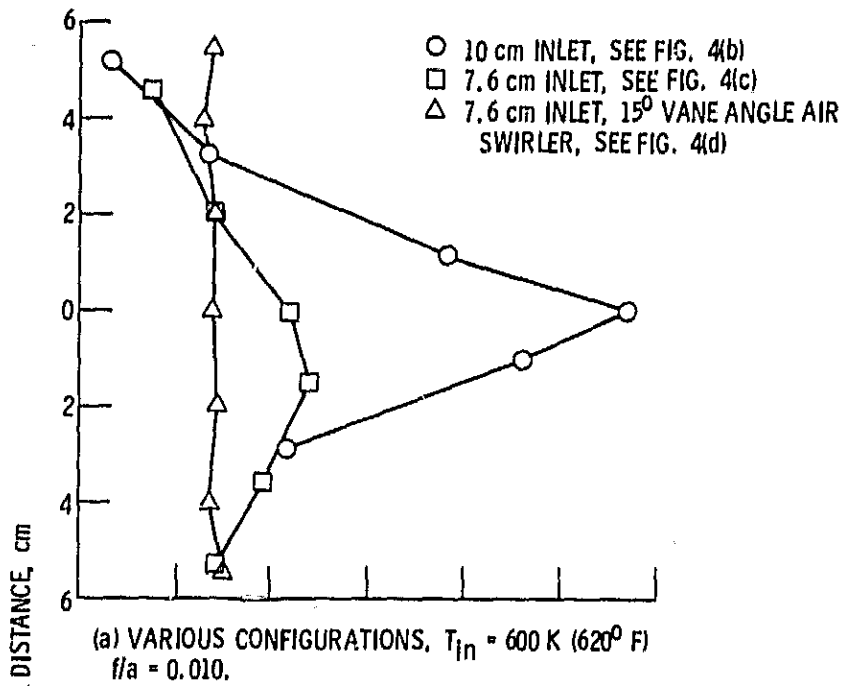

Figure 10. - Spatial fuel distribution, splash-groove fuel injector.

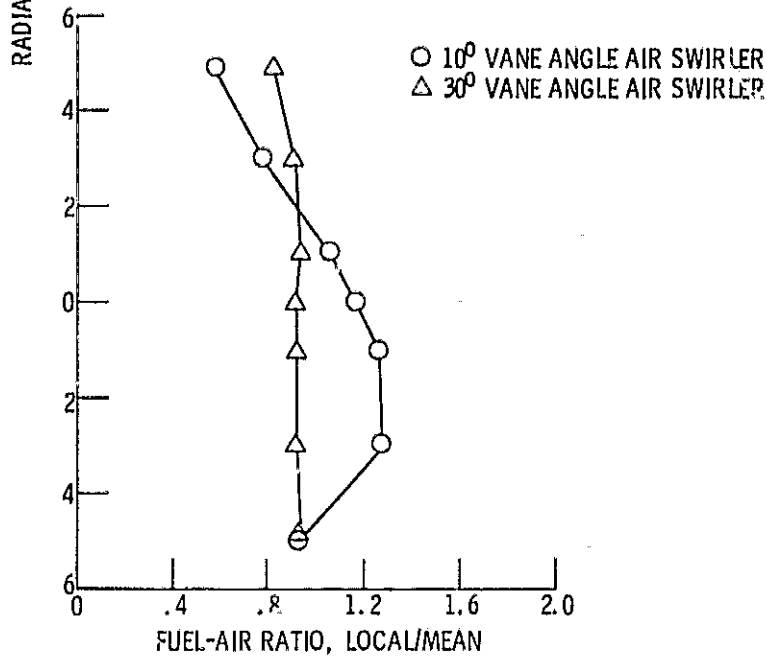
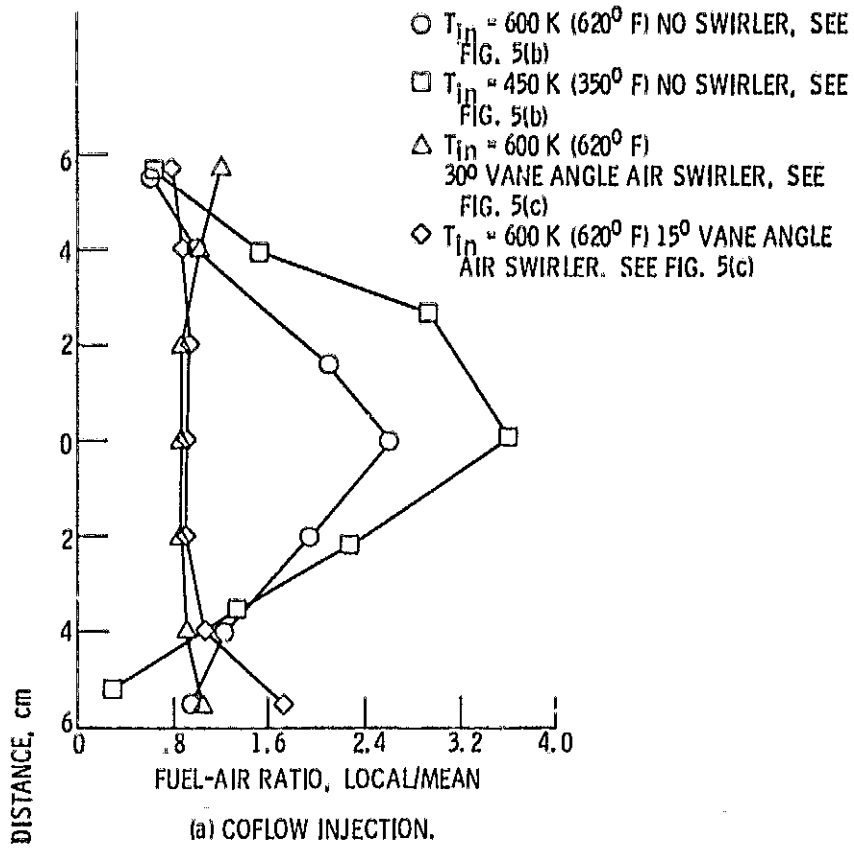

Figure 11. - Spatial fuel distribution, simplex pressure atomizer.

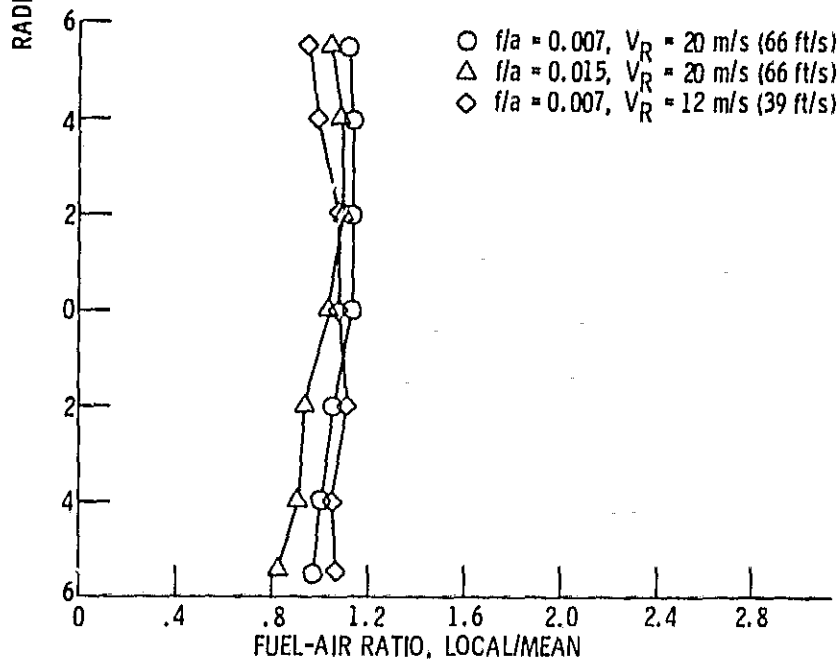
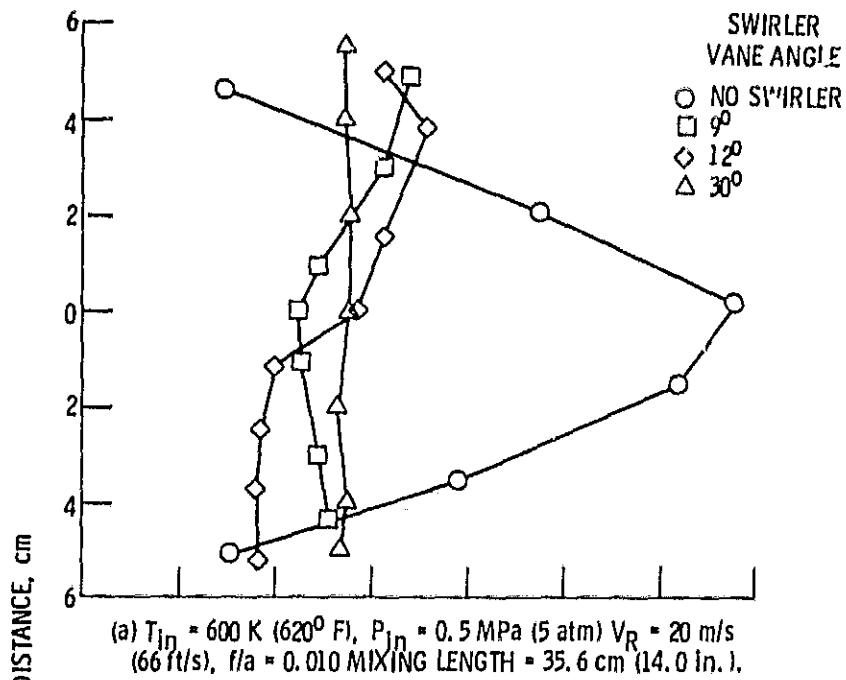

Figure 12. - Spatial fuel distribution, sonicore fuel nozzle, see fig. 6.

E-1301

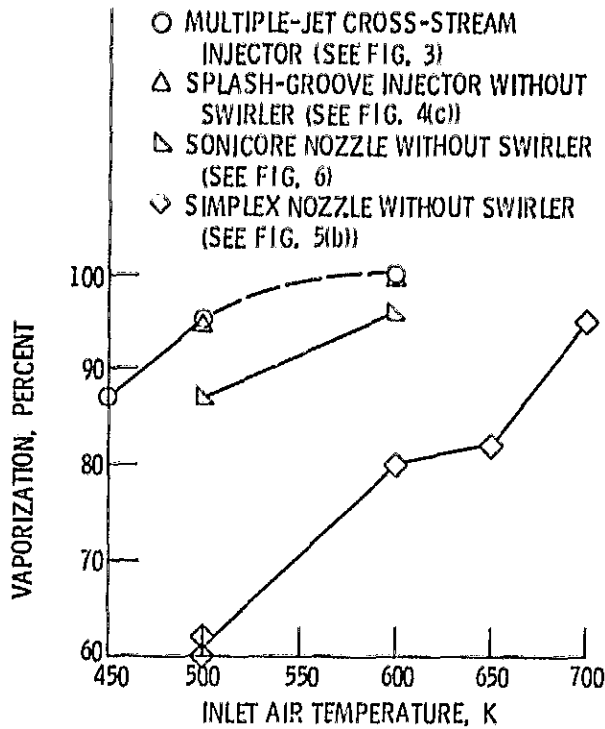

Figure 13. - Effect of inlet air temperature on degree of vaporization for various fuel injectors. Vaporization length nominally 36 cm, $V_R = 20$ m/s (66 ft/s), $P_{in} = 0.5$ MPa (5 atm), $f/a = 0.010$.

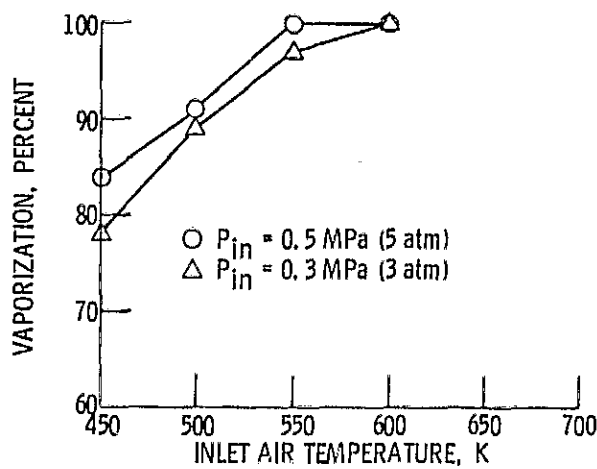

Figure 14. - Effect of inlet air temperature on degree of vaporization for the multiple-jet cross-stream injector at 0.3 MPa (3 atm) and 0.5 MPa (5 atm). Vaporization length = 29.3 cm, $V_R = 20$ m/s, $f/a = 0.010$.