

FINAL REPORT
TRADE-OFF STUDY
OF
DATA STORAGE TECHNOLOGIES

CONTRACT NAS5-24170

(NASA-CR-156672) TRADE-OFF STUDY OF DATA STORAGE TECHNOLOGIES Final Report (RCA Government and Commercial) A01	HC A07/MF CACL 09B	N78-16633 Unclas 03612
		G3/60

Prepared for:
NASA Goddard Space Flight Center
Greenbelt, Maryland 20771

Prepared by:
RCA/Government Communications Systems
Recording Systems
Camden, New Jersey 08100

REPRODUCED BY
**NATIONAL TECHNICAL
INFORMATION SERVICE**
U. S. DEPARTMENT OF COMMERCE
SPRINGFIELD, VA. 22161

BIBLIOGRAPHIC DATA SHEET

1. Report No.		2. Government Accession No.		3. Recipient's Catalog No.	
4. Title and Subtitle Final Report--Trade-Off Study Of Data Storage Technologies				5. Report Date Nov. 1977	
				6. Performing Organization Code	
7. Author(s) R. V. Kadyszewski				8. Performing Organization Report No.	
9. Performing Organization Name and Address RCA/Government Communication Systems Recording Systems Camden, New Jersey 08100				10. Work Unit No.	
				11. Contract or Grant No. NAS5-24170	
12. Sponsoring Agency Name and Address NASA/Goddard Space Flight Center Greenbelt, Md. 20771 (F. McCaleb)				13. Type of Report and Period Covered CR (Formal NASA Report)	
				14. Sponsoring Agency Code	
15. Supplementary Notes					
16. Abstract The need to store and retrieve large quantities of data at modest cost has generated the need for an economical, compact, archival mass storage system. Very significant improvements in the state-of-the-art of mass storage systems have been accomplished through the development of a number of magnetic, electro-optical, and other related devices. This study was conducted in order to do a trade-off between these data storage devices and the related technologies in, order to determine an optimum approach for an archival mass data storage system based upon a comparison of the projected capabilities and characteristics of these devices to yield operational systems in the early 1980's.					
17. Key Words (Selected by Author(s)) Trade-off study Archival mass storage system Transverse high density tape Optical disc				18. Distribution Statement	
19. Security Classif. (of this report) Uncl.		20. Security Classif. (of this page) Uncl.		21. No. of Pages	22. Price*

*For sale by the National Technical Information Service, Springfield, Virginia 22151.

FINAL REPORT
TRADE-OFF STUDY
OF
DATA STORAGE TECHNOLOGIES
CONTRACT NAS5-24170

NOVEMBER 1977

Prepared for:
NASA Goddard Space Flight Center
Greenbelt, Maryland 20771

Prepared by:
RCA/Government Communications Systems
Recording Systems
Camden, New Jersey 08100

ii

iii

preceding page blank

TABLE OF CONTENTS

SECTION		PAGE
1	INTRODUCTION.....	1-1
	1.1 General.....	1-1
2	STUDY OBJECTIVE.....	2-1
	2.1 General	2-1
3	TRADE-OFF STUDY SUMMARY.....	3-1
	3.1 General	3-1
	3.2 Conclusions.....	3-2
4	TECHNICAL APPROACH.....	4-1
	4.1 General.....	4-1
	4.2 Preliminary Trade-Off.....	4-1
	4.3 Transverse High Density Tape & Optical Disc Trade-Off.....	4-2
5	PRELIMINARY TRADE-OFF.....	5-1
	5.1 General.....	5-1
	5.2 Electron Beam Technology.....	5-2
	5.2.1 Electron Beam Devices.....	5-2
	5.2.2 Electron Beam Device Characteristics.....	5-2
	5.2.3 Electron Beam Technology Status.....	5-2
	5.2.4 Electron Beam Technology Application to Archival Data Storage.....	5-2
	5.3 Magnetic Bubble Technology.....	5-4
	5.3.1 Magnetic Bubble Memories.....	5-4
	5.3.2 Magnetic Bubble Memory Characteristics...	5-4
	5.3.3 Magnetic Bubble Technology Status.....	5-4
	5.3.4 Magnetic Bubble Technology Application to Archival Data Storage.....	5-4
	5.4 Magnetic Disc Technology.....	5-6
	5.4.1 Magnetic Disc Storage Devices.....	5-6
	5.4.2 Magnetic Disc Storage Devices Characteristics.....	5-6
	5.4.3 Magnetic Disc Technology Status.....	5-6
	5.4.4 Magnetic Disc Technology Application to Archival Data Storage.....	5-7
	5.5 Longitudinal High Density Tape Recorder Technology.....	5-8
	5.5.1 Longitudinal HDMR.....	5-8
	5.5.2 Longitudinal High Density Tape Recorder Characteristics.....	5-8

**ORIGINAL PAGE IS
OF POOR QUALITY**

TABLE OF CONTENTS (Continued)

SECTION		PAGE
	5.5.3 Longitudinal High Density Tape Recorder Technology Status.....	5-8
	5.5.4 Longitudinal High Density Tape Recorder Technology Application to Archival Data Storage.....	5-8
5.6	Transverse High Density Tape Recorder Technology.....	5-10
	5.6.1 Transverse High Density Tape Recorder.....	5-10
	5.6.2 Transverse High Density Tape Recorder Characteristics.....	5-12
	5.6.3 Transverse High Density Tape Recorder Technology Status.....	5-13
	5.6.4 Transverse High Density Tape Recorder Technology Application to Archival Data Storage.....	5-13
5.7	Optical Film Technology.....	5-14
	5.7.1 Optical Film Recording.....	5-14
	5.7.2 Optical Film Recording Characteristics...	5-14
	5.7.2.1 Photographic.....	5-14
	5.7.2.2 Deformable Medium.....	5-14
	5.7.3 Optical Film Recording Status.....	5-14
	5.7.3.1 Photographic.....	5-14
	5.7.3.2 Deformable Medium.....	5-14
	5.7.4 Optical Film Technology Application to Archival Data Storage.....	5-15
	5.7.4.1 Photographic.....	5-15
	5.7.4.2 Deformable Medium.....	5-15
5.8	Optical Disc Technology.....	5-16
	5.8.1 Optical Disc Recording.....	5-16
	5.8.2 Optical Disc Recording Characteristics...	5-21
	5.8.3 Optical Disc Technology Status.....	5-21
	5.8.4 Optical Disc Technology Application to Archival Data Storage.....	5-21
6	TRANSVERSE HIGH DENSITY TAPE & OPTICAL DISC TRADE-OFF.....	6-1
6.1	General.....	6-1

TABLE OF CONTENTS (Continued)

SECTION		PAGE
6.2	Technology Trade-Off.....	6-3
	6.2.1 Archival Storage Capacity.....	6-3
	6.2.2 Storage Capacity Risk Assessment.....	6-4
	6.2.3 Archival Transfer Rates.....	6-5
	6.2.4 Transfer Rates Risk Assessment.....	6-6
	6.2.5 Archival Transfer Rate Range.....	6-7
	6.2.6 Transfer Rate Range Risk Assessment.....	6-8
	6.2.7 Archival Access Time.....	6-9
	6.2.7.1 HDT Access Time.....	6-10
	6.2.8 Access Time Risk Assessment.....	6-11
	6.2.9 Archival Error Rate.....	6-12
	6.2.10 Error Rate Risk Assessment.....	6-13
	6.2.11 Archival Floor Space.....	6-14
6.3	Derived Archival System Parameters.....	6-15
	6.3.1 Channel Utilization.....	6-15
	6.3.2 Real Volumetric Packing Density.....	6-16
6.4	Operational Parameters.....	6-17
	6.4.1 Expected Failure Rate.....	6-17
	6.4.2 Difficulty of Repair.....	6-17
	6.4.3 Sensitivity of the Device or Storage Medium to the Environment.....	6-18
6.5	Archival Data Storage System Design.....	6-20
	6.5.1 Archival Data Storage System Configuration.....	6-20
	6.5.2 Archival Data Storage System-THDT.....	6-20
	6.5.3 Archival Data Storage System-OD.....	6-23
	6.5.4 Archival Data Storage System- Risk Considerations.....	6-23
6.6	Archival Data Storage System Considerations.....	6-25
	6.6.1 Archive Operational Considerations.....	6-25
	6.6.2 Archive Data Base Management Considerations.....	6-25
	6.6.3 Archive System Design Considerations.....	6-25
6.7	Archival Data Storage System Development Requirements.....	6-26
	6.7.1 Transverse High Density Tape Development Requirements.....	6-26
	6.7.2 Optical Disc Development Requirements....	6-26
6.8	Trade-Off Conclusions.....	6-27

~~ORIGINAL PAGE IS
OF POOR QUALITY~~

Preceding page blank

TABLE OF CONTENTS (Continued)

SECTION		PAGE
7	DEVELOPMENT PROGRAM OUTLINE TO DEMONSTRATE FEASIBILITY OF HIGH RISK ITEMS.....	7-1
7.1	General.....	7-1
7.2	Transverse High Density Tape Development Program.....	7-2
7.3	Optical Disc Development Program.....	7-4

LIST OF ILLUSTRATIONS

TABLE	PAGE
2-1 Data Archive Characteristics.....	2-1
4-1 Risk Assessment For Early 1980's Capabilities.....	4-2

FIGURE	PAGE
5-1 RCA Versabit High Density Recording System.....	5-11
5-2 Versabit Tape Format Recorded Data Track (ASA C98.6).....	5-12
5-3 Engineering Model of RCA OD System	5-17
5-4 RCA Optical Disc System.....	5-18
5-5 OD Record/Reproduce Signal Processing.....	5-20
5-6 Preliminary Trade-Off Conclusions.....	5-22
6-1 Archival Data Storage System.....	6-21
6-2 Archival Data Storage System--THDT.....	6-22
6-3 Archival Data Storage System--OD.....	6-24
7-1 Transverse HDT Development Program.....	7-3
7-2 Optical Disc Development Program.....	7-6

APPENDICES

A. ANALYSIS OF VARIABLE SPEED RECORDING & PLAYBACK WITH A TILTED-HEADWHEEL.....	A-1
B. RECENT ADVANCES IN MAGNETIC RECORDING OF DIGITAL DATA.....	B-1
C. HIGH DENSITY VIDEO RECORDING SYSTEM.....	C-1
D. OPTICAL VIDEO DISC FOR HIGH RATE DIGITAL DATA RECORDING.....	D-1

ORIGINAL PAGE IS
OF POOR QUALITY

SECTION I INTRODUCTION

I.I. GENERAL

The need to store and retrieve large quantities of data at modest cost has generated the need for an economical, compact, archival mass storage system. Very significant improvements in the state-of-the-art of mass storage systems have been accomplished through the development of a number of magnetic, electro-optical, and other related devices. This study was conducted in order to do a trade-off between these data storage devices and the related technologies in order to determine an optimum approach for an archival mass data storage system based upon a comparison of the projected capabilities and characteristics of these devices to yield operational systems in the early 1980's.

SECTION 2
STUDY OBJECTIVE

2.I. GENERAL

The objective of this study was to conduct a trade-off study comparing the various data storage technologies which are projected to yield operational devices and systems by the early 1980's which will meet the requirements listed in Table 2-1. The study shall result in a recommendation to NASA as to which of the various devices studied appear to be most suitable for an archival storage system in a quasi-operational environment similar to that in the NASA-Goddard Image Processing Facility.

TABLE 2-1
DATA ARCHIVE CHARACTERISTICS

System Configuration	Min.	Goal	Max.
Storage Capacity (BITS)	10^{14}	5×10^{14}	10^{15}
Transfer Rates-Max. (MB/S)	50	120	300
Transfer Rate Range	10:1	50:1	---
Access Time (Sec.)	200	100	50
Error Rate	10^{-7}	10^{-8}	---
Floor Space (M ²)	---	100	---

ORIGINAL PAGE IS
OF POOR QUALITY

SECTION 3

TRADE-OFF STUDY SUMMARY

3.1. GENERAL

Various Data Storage Technologies and devices were studied. These included:

Magnetic Devices

High Density Longitudinal Tape Recording

High Density Rotating Head Tape Recording

Magnetic Discs

Electro-Optical Devices

Optical Disc

Optical Photographic Film

Electron Beam Techniques

Solid State Techniques

Other Technologies

Parameters such as storage capacity, transfer rates, transfer rate ranges, access time, and error rate were considered for each of the devices studied. Minimum and maximum achievable values for each of the parameters were estimated and projected to include expected operational devices which should be available for implementation in the early 1980's.

Expected data characteristics were considered in order to derive Archival Mass Storage System parameters such as channel utilization and real volumetric packing density.

An operational analysis was conducted and a needs assessment was made. The NASA-Goddard Image Processing Facility was reviewed as being representative of an Archival Mass Storage facility. Operational parameters such as expected failure rates, difficulty of repair, and sensitivity of the device or the storage medium to the environment were reviewed.

The results of the study are recommendations to NASA as to which of the various devices studied appears to be most suitable for an Archival Storage System in a quasi-operational environment which is similar to that in the NASA-Goddard Image Processing Facility.

Also, an outline is presented for the additional research and development work needed to fully demonstrate the performance of the recommended devices.

3. 2. CONCLUSIONS

The results of the Preliminary Trade-off Study (See Figure 5-1) showed that the Electron Beam, Magnetic Bubble, Magnetic Disc, Longitudinal High Density Tape and Optical Film Technologies did not meet the Archival Data Storage System requirements and were not recommended for consideration for an Archival Data Storage System required for 1983 implementation. The Transverse High Density Tape and Optical Disc Technologies were shown to meet all or most of the Archival Data Storage System requirements. These technologies were recommended for further consideration as candidates for an Archival Data Storage System required for 1983 implementation.

The overall conclusions of the Trade-off study between the transverse high density tape technology and optical disc technology are that the transverse high density tape requires a lower risk development effort and at least a minimum configuration system is more readily implementable with existing equipment. The optical disc, however, is more amenable to the operational requirements of the Archival Data Storage System; but the overall development required is of a much higher risk. Listed below are some of the salient points of the conclusions.

TRANSVERSE HIGH DENSITY TAPE

- LOWER RISK DEVELOPMENT REQUIRED FOR SYSTEM
- SYSTEM EASILY IMPLEMENTABLE NOW AT MINIMUM CONFIGURATION
- PROVEN HARDWARE AVAILABLE AS A BASE
- LONG TERM MEDIUM STORAGE DEMONSTRATED
- SLOW DATA ACCESS
- DATA FILES NOT AS EASY TO HANDLE

OPTICAL DISC

- BETTER SUITED TO OPERATIONAL REQUIREMENTS
- FAST DATA ACCESS
- SEMI AUTOMATIC LOADING & SEQUENCING
- NO MECHANICAL CONTACT WITH MEDIUM DURING READ-WRITE
- HIGHER RISK DEVELOPMENT REQUIRED FOR SYSTEM
- NO HISTORY ON MEDIUM LIFE
- LIMITED HARDWARE DEMONSTRATED

The following sketches are conceptual configurations of an Archival Data Storage System utilizing the Transverse High Density Tape and the Optical Disc Technologies.

ARCHIVAL STORAGE
FOR 5×10^{14} BITS
(2084 $10\frac{1}{2}$ " REELS)

THDT #3
DATA RETRIEVAL
STAGING

THDT #2
DATA RETRIEVAL

THDT #1
DATA STORAGE

CONTROL CONSOLE
DATA INDEXING &
RETRIEVAL LOCATOR

ROOM
SIZE 2×100 M

ARCHIVAL DATA STORAGE SYSTEM - THDT

3-3

ORIGINAL PAGE IS
OF POOR QUALITY

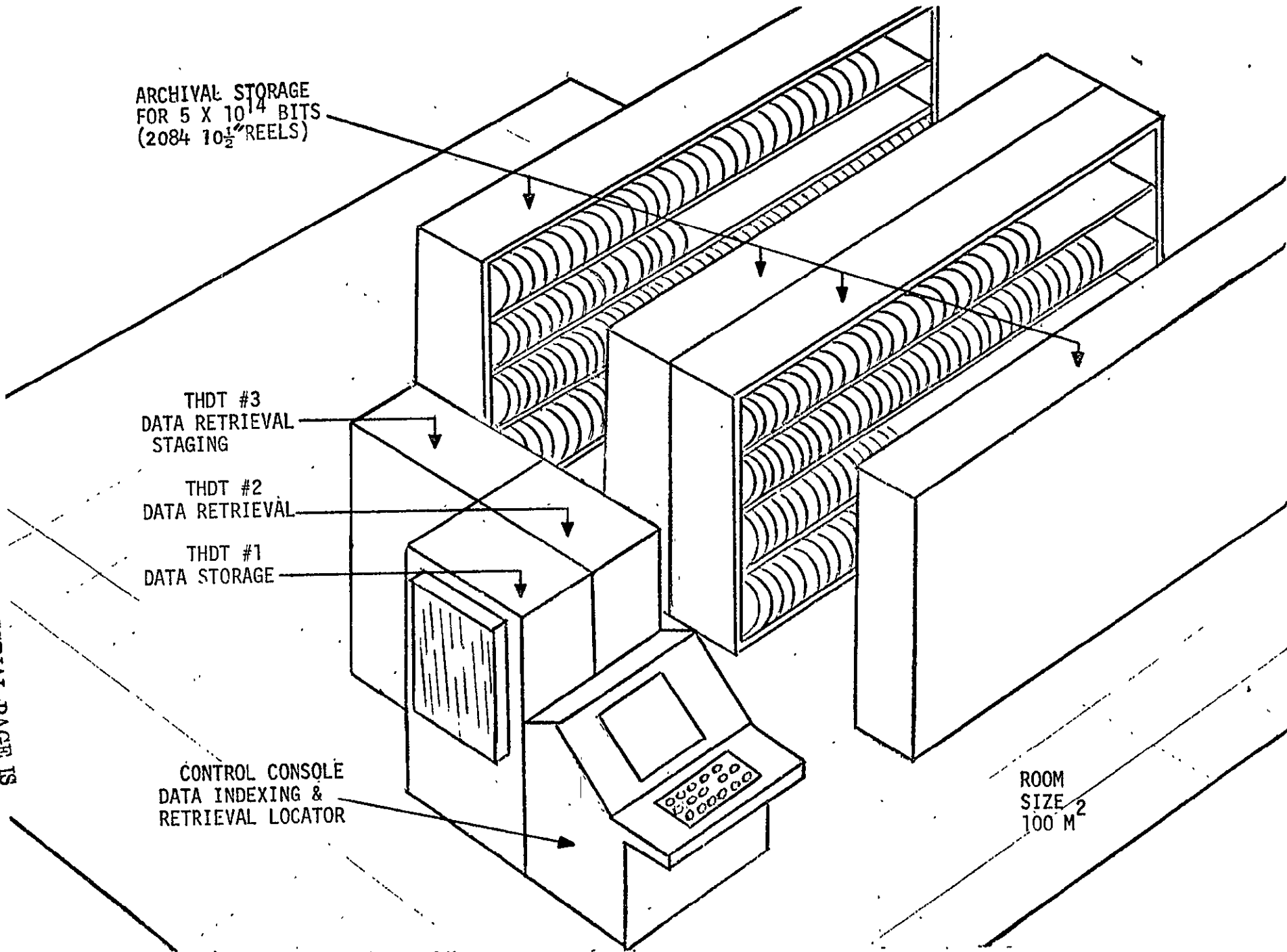

ARCHIVAL STORAGE
FOR 5×10^{14} BITS
(16700 12" DISCS)

OD #3
DATA
RETRIEVAL
STAGING

OD #2
DATA
RETRIEVAL

OD #1
DATA
STORAGE

CONTROL CONSOLE
DATA INDEXING &
RETRIEVAL LOCATOR

ROOM
SIZE
100 M²

ARCHIVAL DATA STORAGE SYSTEM - OD

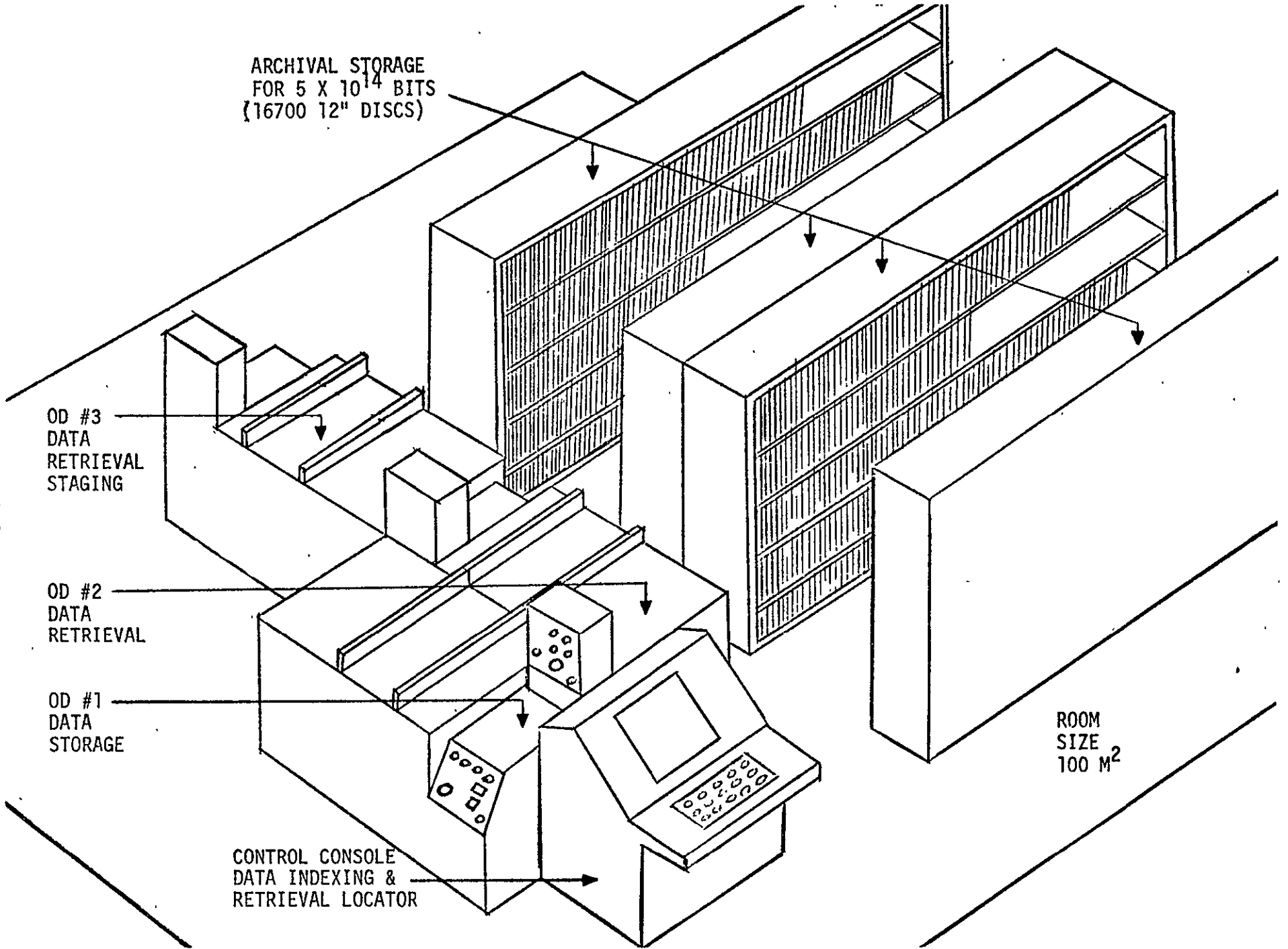

SECTION 4
TECHNICAL APPROACH

4. 1. GENERAL

At the present time, there are no systems specifically configured as Archival Storage Systems. However, there are devices and systems available which can, with proper implementation, form the basis of an Archival Storage System.

The candidate devices and systems which were considered in this study are:

Magnetic Devices

High Density Longitudinal Tape Recording

High Density Rotating Head Tape Recording

Magnetic Discs

Electro-Optical Devices

Optical Disc

Optical Photographic Film

Electron Beam Techniques

Solid State Techniques

Other Technologies

Considering the Data Archive characteristics as specified in Table 2 - 1, all but a few well known and firmly established technologies can be discounted as being viable approaches.

4. 2. PRELIMINARY TRADE-OFF

A Preliminary Trade-off of the various technologies was completed in order to narrow the field to those which are most significant as candidates for an Archival Data Storage System.

A brief description of each of the considered technologies is given. The technology characteristics, both present and projected, are reviewed for each of the technologies. The general present status for each of the technologies is then assessed. Finally, the application of each of the candidate devices and systems relative to the Archival System requirements is demonstrated in order to determine if it is a viable approach for an Archival Data Storage System required for 1983 implementation.

4. 3 . TRANSVERSE HIGH DENSITY TAPE AND OPTICAL DISC TRADE-OFF

A trade-off between the transverse high density tape (THDT) and the optical disc (OD) was conducted. The Data Archive characteristics listed in Table 2 - 1 were used as the main criterion for the trade-off. The estimated minimum achievable values for the transverse high density tape and optical disc characteristics were defined as those presently achievable with the current state of the technology and with the presently available equipment. The estimated maximum achievable values for the transverse high density tape and optical disc characteristics were defined as those projected as achievable in the early 1980's with minimal low risk advances in the state of the technology and realizable hardware advancements. An assessment of the risk involved in achieving the configuration goal characteristics in the early 1980's is given in Table 4 - 1.

TABLE 4-1

RISK ASSESSMENT FOR EARLY 1980's CAPABILITIES

RISK LEVEL	DEFINITION
I NO RISK	<ul style="list-style-type: none"> ● SYSTEMS AND/OR HARDWARE AVAILABLE AT PRESENT ● NO DEVELOPMENT REQUIRED
II LOW RISK	<ul style="list-style-type: none"> ● TECHNOLOGY EXISTS ● HARDWARE SYSTEMS HAVE BEEN DEMONSTRATED
III MEDIUM RISK	<ul style="list-style-type: none"> ● FURTHER ADVANCES IN TECHNOLOGY REQUIRED ● SOME SYSTEM ELEMENTS HAVE BEEN DEMONSTRATED ● HARDWARE DEVELOPMENT REQUIRED
IV HIGH RISK	<ul style="list-style-type: none"> ● ADVANCES IN THE STATE-OF-THE-ART REQUIRED ● NO HARDWARE OR SYSTEMS AVAILABLE AT PRESENT ● NO DEMONSTRATION OF CAPABILITIES HAVE BEEN MADE

System Parameters were derived for channel utilization and real volumetric packing density. Operational parameters such as expected failure rates, difficulty of repair and sensitivity of the device or storage medium to the environment were compared for each of the technologies.

An Archival Data Storage System design concept has been formulated. See Figure 6 - 1 for a block diagram of the system.

The major elements of the system are the administrative command and control system and the data base management system.

In order to eventually implement a system concept for an Archival Data Storage System, certain parameters were formulated as being important operational consideration, data base management configuration considerations, and Archival System design considerations.

The development requirements to improve the capabilities of both the transverse high density tape and optical disc units in order to meet the Archival Data Storage System's configuration goal in the early 1980's are outlined.

SECTION 5

PRELIMINARY TRADE-OFF

5. 1. GENERAL

A Preliminary Trade-Off of the various technologies was completed in order to narrow the field to those which are most significant as candidates for an Archival Data Storage System. The criterion for the trade-off was the following Archival System requirements:

System Configuration	Min.	Goal	Max.
Storage Capacity, BITS	10 ¹⁴	5 X 10 ¹⁴	10 ¹⁵
Transfer Rates, MBITS/SEC	50	120	300
Transfer Rate Range	10:1	50:1	---
Access Time, SEC.	200	100	50
Error Rate	10 ⁻⁷	10 ⁻⁸	---
Space Requirements, M ²	---	100	---

The candidate devices and systems which were considered in this study are:

Magnetic Devices

- High Density Longitudinal Tape Recording
- High Density Rotating Head Tape Recording
- Magnetic Discs

Electro-Optical Devices

- Optical Disc
- Optical Photographic Film

Electron Beam Techniques

Solid State Techniques

Other Technologies

The present and forecasted characteristics of each of the candidate devices and systems were reviewed along with the general present status of the related technology. The application of each of the candidate devices and systems relative to the Archival System requirements was demonstrated in order to determine if it was a viable approach for an Archival Data Storage System required for 1983 implementation.

ORIGINAL PAGE IS
OF POOR QUALITY

5. 2. ELECTRON BEAM TECHNOLOGY (Not recommended for Archival Storage)

5. 2. 1. ELECTRON BEAM DEVICES

High speed as well as high density characterized the electron beam memories. Basically, information is stored and read from a reversible action type target which is typically made of silicon dioxide. A high-resolution electron beam is used to store and retrieve data stored as electrostatic charges.

Storage tubes with capacities ranging from 128 kilobits to 32 megabits have been developed. Systems employing the electron beam devices consist of an array of storage tubes connected in parallel.

Access time to block of data in these systems ranges from 5 microseconds to 30 microseconds and depends on the capacity of the storage tube. Once a specific block of data has been accessed, an additional 0.5 microseconds is required for each particular bit accessed.

5.2.2. ELECTRON BEAM DEVICE CHARACTERISTICS

CAPACITY, MBITS/TUBE --- 32, FORECAST 100
TRANSFER RATE, MBITS/SEC. --- 10, FORECAST 100
ACCESS TIME
TO BLOCK OF DATA --- 10's OF MICROSECONDS
TO READ OUT DATA --- 10 ^{THS} OF MICROSECONDS/BIT
NON VOLATILE (FOR A LIMITED PERIOD OF MONTHS)
PARALLEL OPERATION OF STORAGE TUBES
COST --- .02¢/BIT

5.2.3. ELECTRON BEAM TECHNOLOGY STATUS

LIMITED DEVELOPMENT EFFORT --- PRIMARILY MICRO-BIT & G. E.
MICRO-BIT --- SYSTEM 7000, 18 PARALLEL TUBES
4 MBITS/TUBE
72 MBITS CAPACITY
G. E. --- BEAMOS SYSTEM, 32 MBITS/TUBE
10 MBITS CAPACITY
VOLUME/STORAGE TUBE --- 2 TO 3 FT. ³
POWER/STORAGE TUBE --- 250 WATTS

4. ELECTRON BEAM TECHNOLOGY APPLICATION TO ARCHIVAL DATA STORAGE

ARCHIVAL STORAGE CAPACITY GOAL --- 5×10^{14} BITS
FOR 10^8 BITS/TUBE, THE SYSTEM REQUIRES 5×10^6 TUBES
FOR 250 WATTS/TUBE, THE SYSTEM REQUIRES 1.25×10^6 TUBES
FOR 2 FT ³ /TUBE, THE SYSTEM REQUIRES 10^7 FT ³
FOR .02¢/BIT, THE SYSTEM COSTS $\$10^{11}$
EVEN FOR .0002¢/BIT, THE SYSTEM COSTS $\$10^9$

The optimistic projection for operating systems employing this technology is in the 1980 to 1985 time period. There is presently no operational or environmental data compiled for these systems. The storage decay time for greater than one year is not acceptable. A very high risk development effort is required to meet the defined goals for the Archive Data Storage System.

The Electron Beam Technology is not recommended for consideration for an Archival Data Storage System required for 1983 implementation.

5. 3. MAGNETIC BUBBLE TECHNOLOGY (Not recommended for Archival Storage)

5. 3. 1. Magnetic Bubble Memories

Magnetic bubble memories are nonvolatile high density solid-state devices. Packing densities of 100K bits/chip have been developed. These memories operate in an asynchronous mode and require no refresh or standby power. Data access time is in the 1 to 5 msec range with data rates of 100 to 500 KHz.

5. 3. 2. Magnetic Bubble Memory Characteristics

SOLID STATE DEVICES NON VOLATILE NO STAND-BY POWER REQUIRED CAPACITY, MBITS/CHIP --- PRESENT .1, 1987 10 TRANSFER RATE, MBITS/SEC --- PRESENT .1 to 10, 1990's 10 TO 100 STORAGE DENSITY, MBITS/IN ² --- PRESENT 2, 1985-1990 10 TO 100 ACCESS TIME, MSEC --- PRESENT 1 TO 5, 1985-1990 .1 TO 1 POWER/CHIP, WATTS --- .1 TO .5 COST/BIT -- .2¢, 1985 - 1990 .001¢.

5. 3. 3. 'MAGNETIC BUBBLE TECHNOLOGY STATUS

HEAVILY SUPPORTED DEVELOPMENT EFFORT ACTIVE FIELD OF STUDY SINCE 1967 EMPHASIS ON APPLICATIONS NOW SERVICED BY MAG. DISC & MAG. DRUM MEMORIES NOT IN VOLUME PRODUCTION NO MANUFACTURING EXPERIENCE TO PROVE RELIABILITY SAMPLE MEMORY MODULES AVAILABLE RELEASED PRODUCTS FROM TI INCLUDE: MODEL 765 PORTABLE MEMORY TERMINAL MODEL 763 MEMORY SEND-RECEIVE TERMINAL

5. 3. 4. MAGNETIC BUBBLE TECHNOLOGY APPLICATION TO ARCHIVAL DATA STORAGE

ARCHIVAL STORAGE CAPACITY GOAL --- 5×10^{14} BITS FOR .1 MBIT/CHIP, THE SYSTEM REQUIRES 5×10^9 CHIPS FOR 100 CHIPS/CARD, THE SYSTEM REQUIRES 5×10^7 CARDS FOR 25 CARDS/19"W X 12"H NEST, THE SYSTEM REQUIRES 2×10^6 NESTS FOR 5 NESTS/6'H RACK, THE SYSTEM REQUIRES 4×10^5 RACKS FOR 2.2 FT ² (21"W X 15"D)/RACK, THE SYSTEM REQUIRES 8.8×10^5 FT ² (8178M ²) ARCHIVAL SPACE REQUIREMENT GOAL --- 100M ² (1076 FT ²) FOR .1 WATT/CHIP, THE SYSTEM REQUIRES 5×10^5 KW FOR .2¢/BIT, THE SYSTEM COSTS $\$10^{12}$ EVEN FOR .001/BIT, THE SYSTEM COSTS $\$5 \times 10^9$
--

ORIGINAL PAGE IS
OF POOR QUALITY

There is presently no operating or lifetime experience available for these systems. A high risk, long term development effort is required to meet the defined goals for the Archive Data Storage System.

The magnetic bubble technology is not recommended for consideration for an Archival Data Storage System required for 1983 implementation.

5. 4. MAGNETIC DISC TECHNOLOGY (Not recommended for Archival Storage)

5. 4. 1. MAGNETIC DISC STORAGE DEVICES

Magnetic disc storage devices are generally classified into two categories, fixed head and moving head. The recording media used in both categories is either rigid magnetic discs or floppy discs. Typically, the floppy discs are used almost exclusively with movable head disc system whereas the rigid discs are used with drum and fixed head disc systems as well as movable head disc systems.

Fixed head rigid disc systems have access times ranging from 2 to 20 msec while moving head rigid disc systems have access times ranging from 20 to 80 msec. Floppy discs on moving head systems have access times one order of magnitude greater and are typically in the range of 400 msec.

Moving head disc systems generally have a capacity between 10^7 and 10^9 bytes while the capacity of drum and fixed head discs is between 10^6 and 10^8 bytes.

A number of broad functional categories must be considered for each type of disc system. These categories include read/write mechanisms, recording techniques, control interfaces, memory systems, packaging, and performance.

5.4.2 MAGNETIC DISC STORAGE DEVICE CHARACTERISTICS

STORAGE CAPACITY, MBITS/DISC	---	FLEXIBLE DISC	3.2
		RIGID CARTRIDGE DISC	400
		DISC PACK	2540
TRANSFER RATE, MBITS/SEC	---	DISC PACK	9.6
ACCESS TIME	---	30 MILLISECONDS	
ERROR RATE	---	10 ⁻⁹	
POWER REQUIREMENTS	---	1.2 KVA/DRIVE (DISC PACK)	
		1 KVA/CONTROLLER	
COST	---	.005¢/BIT	
SPACE REQUIREMENTS	---	4.5 FT. ² /DRIVE (DISC PACK)	
		7.5 FT. ² /CONTROLLER	

5.4.3 MAGNETIC DISC TECHNOLOGY STATUS

TECHNOLOGY WELL DEVELOPED
FLEXIBLE & RIGID DISC SYSTEMS AVAILABLE
ACTIVE FIELD OF STUDY SINCE 1950'S
MANY COMPETITIVE COMPANIES
SYSTEMS WITH 1.6×10^{11} BITS OF STORAGE PRESENTLY AVAILABLE
PRESENTLY LITTLE INCENTIVE TO BUILD HIGHER CAPACITY SYSTEMS
INTEGRATED MAGNETIC HEADS WILL INCREASE DISC DENSITY

5.4.4 MAGNETIC DISC TECHNOLOGY APPLICATION TO ARCHIVAL DATA STORAGE

ARCHIVAL STORAGE CAPACITY GOAL --- 5×10^{14} BITS
FOR 1.6×10^{11} BITS/SYSTEM (MAX. AVAILABLE SIZE), THE
SYSTEM REQUIRES 64 DISC PACK DRIVES AND 1 CONTROLLER
FOR 2.5×10^9 BITS/DISC PACK, THE SYSTEM REQUIRES
 2×10^5 DISC PACKS
FOR 2×10^5 DISC PACKS STORED 5 HIGH (16"D X 16"W),
THE SYSTEM REQUIRES 7.1×10^4 FT.² (660M²)
ARCHIVAL SPACE REQUIREMENT GOAL --- 100M² (1076 FT.²)
FOR 1.2 KVA/DISC PACK DRIVE, THE SYSTEM REQUIRES
76.8 KVA
FOR .005¢/BIT, THE SYSTEM COST $\$2.5 \times 10^{10}$

The magnetic disc packs are designed to interface with a Host CPU.
They are primarily intended to be used with on-line interactive systems.

The magnetic disc technology is not recommended for consideration for
an Archival Data Storage System required for 1983 implementation.

**ORIGINAL PAGE IS
OF POOR QUALITY**

5. 5. LONGITUDINAL HIGH DENSITY TAPE RECORDER TECHNOLOGY

(Not recommended for Archival Storage)

5. 5. 1. Longitudinal HDMR

Longitudinal high density multitrack recording techniques employ ultra high track density longitudinal heads. Track densities of more than 80 tracks per inch yielding an area packing density of over 2×10^6 BITS/IN.² with an in-track density of 25,000 BITS/IN. have been achieved. A two inch, 164 track HDMR operating at 30 IPS records at the same data rate as a 28 track IRIG version operating at 120 IPS but requires only 2/3 of the in-track density. This provides a more reliable head-to-tape interface and increased tape utilization.

5.5.2 Longitudinal High Density Tape Recorder Characteristics

TRANSFER RATE, MBITS/SEC. ---	240, PROJECTED	600
STORAGE CAPACITY, MBITS/IN ² --	2, PROJECTED	5
TRACK DENSITY, TRACKS/IN ---	60, PROJECTED	100
TAPE SPEED, IN/SEC. ---	100	
BIT ERROR RATE ---	2×10^{-6} , PROJECTED	10^{-8}

5.5.3 Longitudinal High Density Tape Recorder Technology Status

DEMONSTRATED 70 TRACKS/IN DENSITY
DEMONSTRATED 2 MBITS/SEC/CHANNEL
WELL ESTABLISHED TECHNOLOGY BASE
LONG TERM HISTORY OF OPERATIONAL & RELIABILITY CHARACTERISTICS

5.5.4 Longitudinal High Density Tape Recorder Technology Application to Archival Data Storage

ARCHIVAL STORAGE CAPACITY GOAL ---	5×10^{14} BITS
FOR 4.6×10^5 MBITS/9600' REEL (2 MBITS/IN ²), THE	
SYSTEM REQUIRES 1086 REELS OF STORAGE	
FOR 3" WIDTH/STORED REEL AND 4 ROWS OF STORAGE (3" X 16" X 16")	
THE SYSTEM REQUIRES 150 FT. ² (14M ²)	
ARCHIVAL SPACE REQUIREMENT GOAL ---	100M ² (1076 FT. ²)
THE ESTIMATED SYSTEM COST IS	$\$3 \times 10^6$

Development effort is required to meet the Archival Data Storage System goals as defined. This development would improve the capability for:

FASTER START - STOP TIME
INCREASED TAPE SPEED
INCREASED SHUTTLE SPEED
INCREASED STORAGE DENSITY
INCREASED TRACK DENSITY

The Longitudinal High Density Tape Recorder Technology was initially recommended for consideration for an Archival Data Storage System required for 1983 implementation. This was primarily due to the high packing density and the high data rate (300MB/Sec.) requirements. However, this technology was eventually excluded because the 300 MB/Sec. requirement was considered unrealistic because of the additional complexity and cost that would be required.

5.6. TRANSVERSE HIGH DENSITY TAPE RECORDER TECHNOLOGY

(Recommended for Archival Storage)

5.6.1. Transverse High Density Tape Recording

Transverse high density recording techniques employ rotating heads which record data across the width of the tape. The tape width is guided in a 90° arc in the area of the rotating head. As the servo controlled rotating head rotates 90°, data is recorded across the width of the tape. As the head leaves the edge of the tape, a second head located on the headwheel 90° from the first head arrives at the opposite side of the tape to begin recording a second line of data. Each head pass is a complete independent event. A quadruplex system employs 4 heads on the headwheel. The longitudinal tape motion is just sufficient so that a line of data across the tape does not overlap the preceding one. The recording scheme is essentially a single channel of serial data time multiplexed between 4 rotating heads. All input and output data is completely buffered. Since the transverse scan decouples the data from the longitudinal tape motion, tape flutter and time base errors are eliminated. Also, this decoupling allows varying data rates to be accommodated.

The RCA VERSABIT High Density Recording System, which is in a state of rapid performance improvement, is shown in Figure 5-1. This tape system has one reel of tape capacity of about 3×10^{11} bits with BER of about 5×10^{-7} .

VERSABIT uses a tape format which has become the standard format for worldwide use in TV, radar, wideband, ELINT and digital applications. The auxiliary (longitudinal tracks) and transverse track format is shown in Figure 5-2. The VERSABIT utilization of the "video" track is also shown in Figure 5-2.

VERSABIT blocks 2^{14} or 16,384 data bits on each head scan (swipe) across the tape (at 10,000 bpi, 2^{14} bits of data transfer for every 90° of head rotation). These 16,384 data bits are placed in the center 1.6 inches of the tape. The actual signal burst recorded is 1.8 inches long. The 12 percent overlap provides an overhead capability which is used for data scan framing purposes. Approximately 5 percent is allocated as header/preamble and the remaining 7 percent is allocated to Error Detection and Correction (EDAC). Data is therefore transferred in 2^{14} bit blocks with associated overhead bits. Each block is independently reproduced and one block has no effect on another's performance. Decoupling the recorder internal characteristics from the outside world makes the interface straightforward.

The VERSABIT system easily accommodates varying data rates because the input/output data rates are fully decoupled from the record/play data transfer rates by the RAM. The heads always transfer data at the highest rates of recorder operation. This provides constant BER at all data IN/OUT rates. For lower data record/reproduce rates the record/reproduce duty cycle is reduced from 100 percent to a percentage proportional to the data rate reduction.

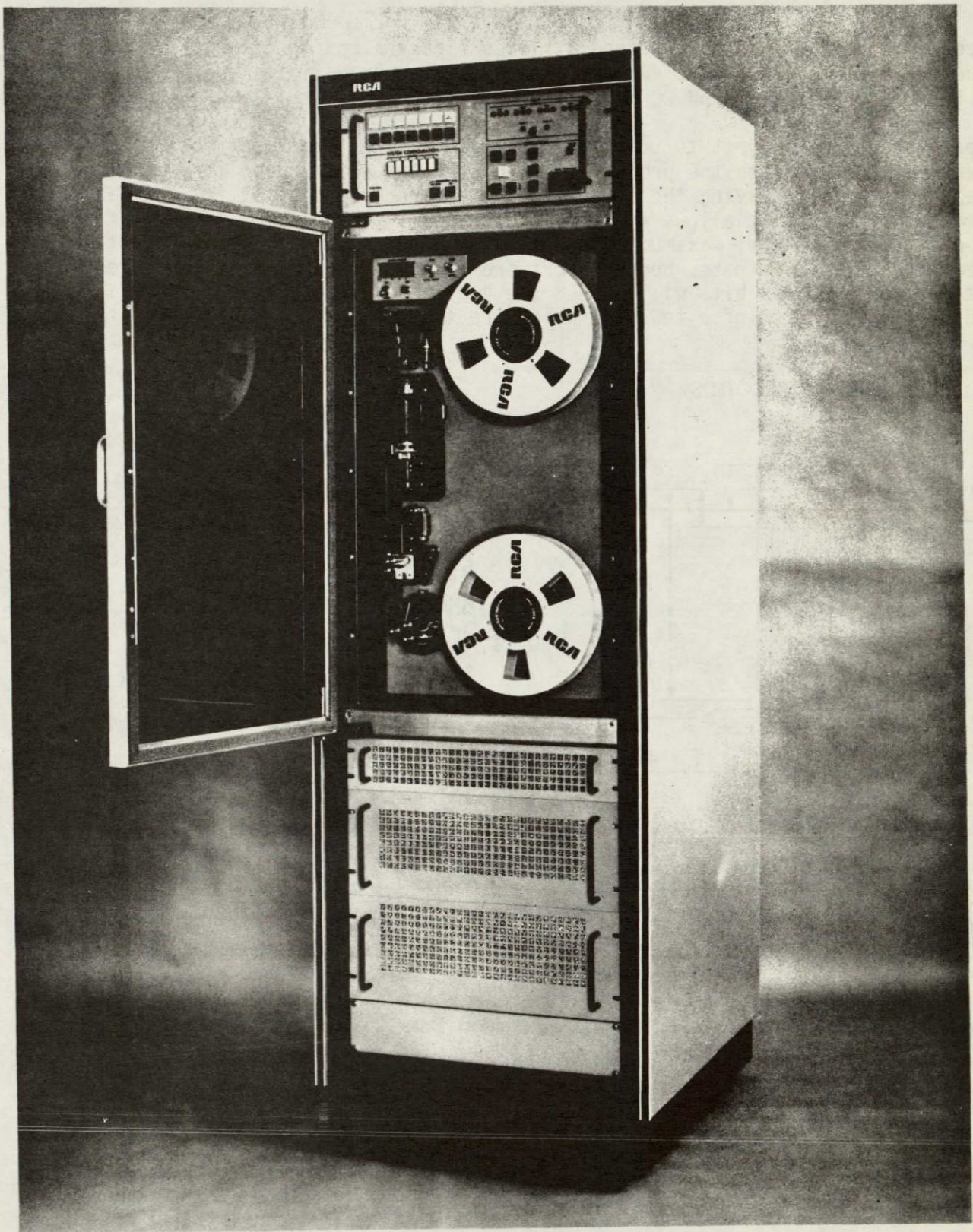
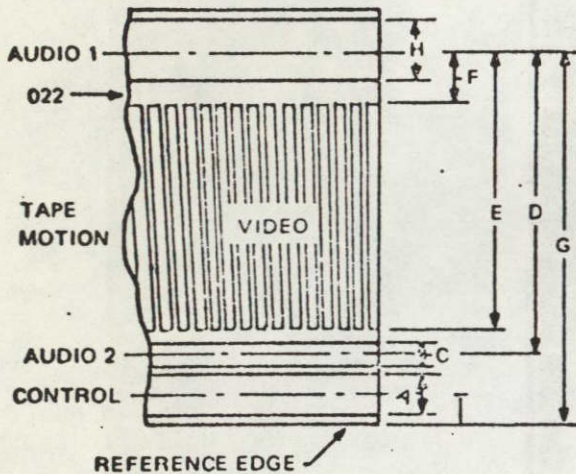

Figure 5-1. RCA VERSABIT High Density Recording System

The recorder speed-up/slow-down method utilizes binary steps in data rate and head duty cycle. Six ranges cover a 40:1 data rate range. Rate limits are arbitrarily set at 500 kilobits/second and 20 megabits/second per channel.

All tape systems are subject to some long dropouts due to tape imperfections or damage. VERSABIT circumvents the problem of long dropouts which cause long bursts of data error by interleaving the data before it is recorded. That is, they are recorded in an order that allows a burst error of up to 512 bits on tape to affect only 4 data bits in a row, maximum, making them correctable with a 4 bit burst EDAC. This technique also eliminates burst errors from VERSABIT when EDAC is not used. Dropouts longer than 512 bits will exceed the 4-bit EDAC capacity, but are still reduced to a short burst of a few bits which are tolerable to many host systems.

POSITION OF RECORDS
ASA C-98.6



151 BITS LOCK-UP
591 BITS HEADER
16,384 BITS DATA
1,408 BITS EDAC
151 BITS SCAN TOLERANCE

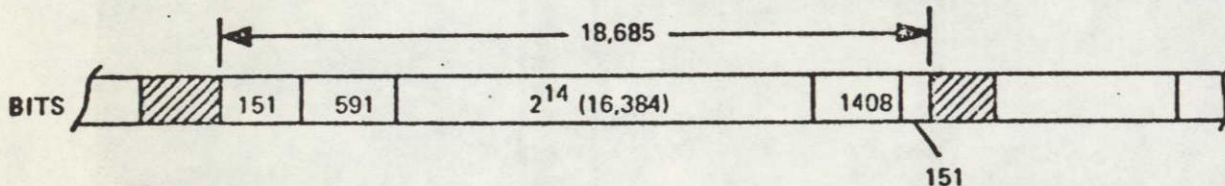

Figure 5-2. VERSABIT Tape Format Recorded Data Track (ASA C98.6)

5.6.2 Transverse High Density Tape Recorder Characteristics

CAPACITY, MBITS/2" X 9600' REEL	---	4.8 X 10 ⁵ , 1980-85	---	9.6 X 10 ⁵	
TRANSFER RATE, MBITS/SEC.	----	.6 → 40, 1980-85	----	100	
ERROR RATE	---	10 ⁻⁵ ,	1980-85	----	10 ⁻¹¹
				(WITH 100%) (REDUNDANCY)	
STORAGE DENSITY, MBITS/IN ²	----	2,	1980-85	----	4

5.6.3 Transverse High Density Tape Recorder Technology Status

HEAVILY SUPPORTED DEVELOPMENT EFFORT BY A FEW COMPANIES
LONG TERM HISTORY OF OPERATIONAL & RELIABILITY CHARACTERISTICS
DELIVERED PRODUCTION UNITS IN USE
DEMONSTRATED FEASIBILITY OF PROJECTED CHARACTERISTICS
INDUSTRY STANDARD FOR IMAGE RECORDING

5.6.4 Transverse High Density Tape Recorder Technology Application to Archival Data Storage

ARCHIVAL STORAGE CAPACITY GOAL --- 5×10^{14} BITS
For 4.8×10^{11} BITS/REEL, THE SYSTEM REQUIRES 1042 REELS
FOR 3" WIDTH/STORED REEL AND 4 ROWS OF STORAGE (3" X 16" X 16")
THE SYSTEM REQUIRES 87 FT.2 (8.1M²)
ARCHIVAL SPACE REQUIREMENT GOAL --- 100M² (1076 FT.2)
The estimated system cost is \$106

Development effort is required to meet the Archival Data Storage System goals as defined. This development would improve the capability for:

INCREASED STORAGE DENSITY
INCREASED DATA RATE
IMPROVED ERROR RATE
HIGH SPEED SEARCH

The Transverse High Density Tape Recorder Technology is recommended for consideration for an Archival Data Storage System required for 1983 implementation.

5. 7. OPTICAL FILM TECHNOLOGY (Not recommended for Archival Storage)

5. 7. 1. Optical Film Recording

The optical film recording process is basically divided into two categories, photographic and deformable medium. Both are thick film recording techniques and require processing of the film. The photographic process uses a light sensitive emulsion whereas the deformable medium employs a thermal deformation technique.

5. 7. 2. Optical Film Recording Characteristics

5. 7. 2. 1. Photographic

WET FILM PROCESS
STORAGE DENSITY, MBITS/IN² -- 100 (DEMONSTRATED)
TRANSFER RATE, MBITS/SEC --- 40

5.7.2.2. Deformable Medium

NON CONTACT RECORDING
ANALOG DATA ON THICK FILM
STORAGE DENSITY, MBITS/IN² --- 30
TRANSFER RATE, MBITS/SEC ---- 200

5.7.3 Optical Film Recording Status

5.7.3.1 Photographic

LIMITED DEVELOPMENT EFFORT
THICK FILM RECORDING --- 3 MIL
BASIC ERROR RATE --- 10⁻⁵, 10⁻⁷ WITH ERROR CORRECTION
HARRIS SYSTEM --- 5 MBITS/IN² DENSITY ($\frac{1}{60}$ OF DEMONSTRATED)

5.7.3.2 Deformable Medium

LIMITED DEVELOPMENT EFFORT
THICK FILM RECORDING ---- 5 MIL
BASIC ERROR RATE --- 10⁻⁴
HONEYWELL HOLOGRAPHY SYSTEM --- *30 MBITS/IN² DENSITY
200 MBITS/SEC. TRANSFER RATE

*Objective Specification

5.7.4 Optical Film Technology Application to Archival Data Storage

5.7.4.1 Photographic

SPECIAL HANDLING REQUIRED FOR UNDEVELOPED FILM
GOOD TEMP. & HUMIDITY CONTROL REQUIRED FOR MEDIUM STORAGE
NOMINAL MEDIUM STORAGE LIFE --- 2 TO 20 YRS.

A Long Term Development Program is Required For:

SCRATCHING & FILM PEELING PREVENTION
LONG TERM STORAGE STABILITY
FILM PACKAGING & HANDLING

5.7.4.2 Deformable Medium

SPECIAL CLEANLINESS REQUIREMENTS FOR FILM HANDLING
NON LINEAR TRANSFER CHARACTERISTICS
ANALOG RECORDING

A Long Term Development Program is Required For:

MEDIUM MATERIALS
FILM PACKAGING & HANDLING
PROCESSING

The Optical Film Technology is Not Recommended For Consideration For
an Archival Data Storage System Required For 1983 Implementation

ORIGINAL PAGE IS
OF POOR QUALITY

5. 8. OPTICAL DISC TECHNOLOGY (RECOMMENDED FOR ARCHIVAL STORAGE)

5. 8. 1. Optical Disc Recording

The Optical disc recording has a high data density and a high data transfer rate as is required to meet the archival data storage requirements. This basic system's function applies to both an analog or digital storage system. The recording disc is placed on a turntable supported by a high precision air bearing. The rotational speed of the turntable is servo controlled by the motor servo electronics. This part of the system compares the tachometer output (rotational velocity) to a reference from the control mode logic and drives the motor to equalize the two. Recording is accomplished by exposing the disc to the modulated radiation from a laser. The laser beam is focused onto the disc to form a very small series of spots (determined by modulation). The optical system has a very short depth of focus and therefore requires constant repositioning of the focusing lens to keep the laser spot focused onto the microscopically uneven disc surface. The position of the laser spot on the disc is determined by the position of the track mirror and a spiral or circular track can be traced. This provides for recording both continuous or single frame (one frame per disc revolution) information. During playback the laser power is reduced and the illumination level to the disc is held constant. Since the recorded information is in a series of slots (determined by laser modulation), information is impressed through some form of coding. In the case of analog video, information is put on by using an FM coding scheme. Information is recorded on the OD as a two-level signal (binary coded). This is due to the fact that recording is accomplished by removing material on the disc by the "write" laser. Thus, the basic signal format is binary in nature.

The engineering model of the RCA Optical Disc System is shown in Figure 5-3. Figure 5-4 shows a block diagram of the RCA Optical Disc System. It has a high data density and a high data transfer rate as is required to meet the archival data storage requirements. This basic system functional diagram applies to both an analog or digital storage system. The record disc, which is a proprietary development of RCA Corporation, is placed on a turntable supported by a high precision air bearing. The rotational speed of the turntable is servo controlled by the motor servo electronics. This part of the system compares the tachometer output (rotational velocity) to a reference from the control mode logic and drives the motor to equalize the two.

Recording is accomplished by exposing the disc to the modulated radiation from the laser. This radiation is passed through beam-forming optics and directed towards the disc by the track mirror. The laser beam is focused onto the disc to form a very small series of spots (determined by modulation).

The optical system has a very short depth of focus and therefore, requires constant repositioning of the focusing lens to keep the laser spot focused onto the microscopically uneven disc surface. The focus servo accomplishes this task by sensing the distance between the focus lens and the disc surface and then driving a transducer to maintain this fixed distance.

5-17

ORIGINAL PAGE IS
OF POOR QUALITY

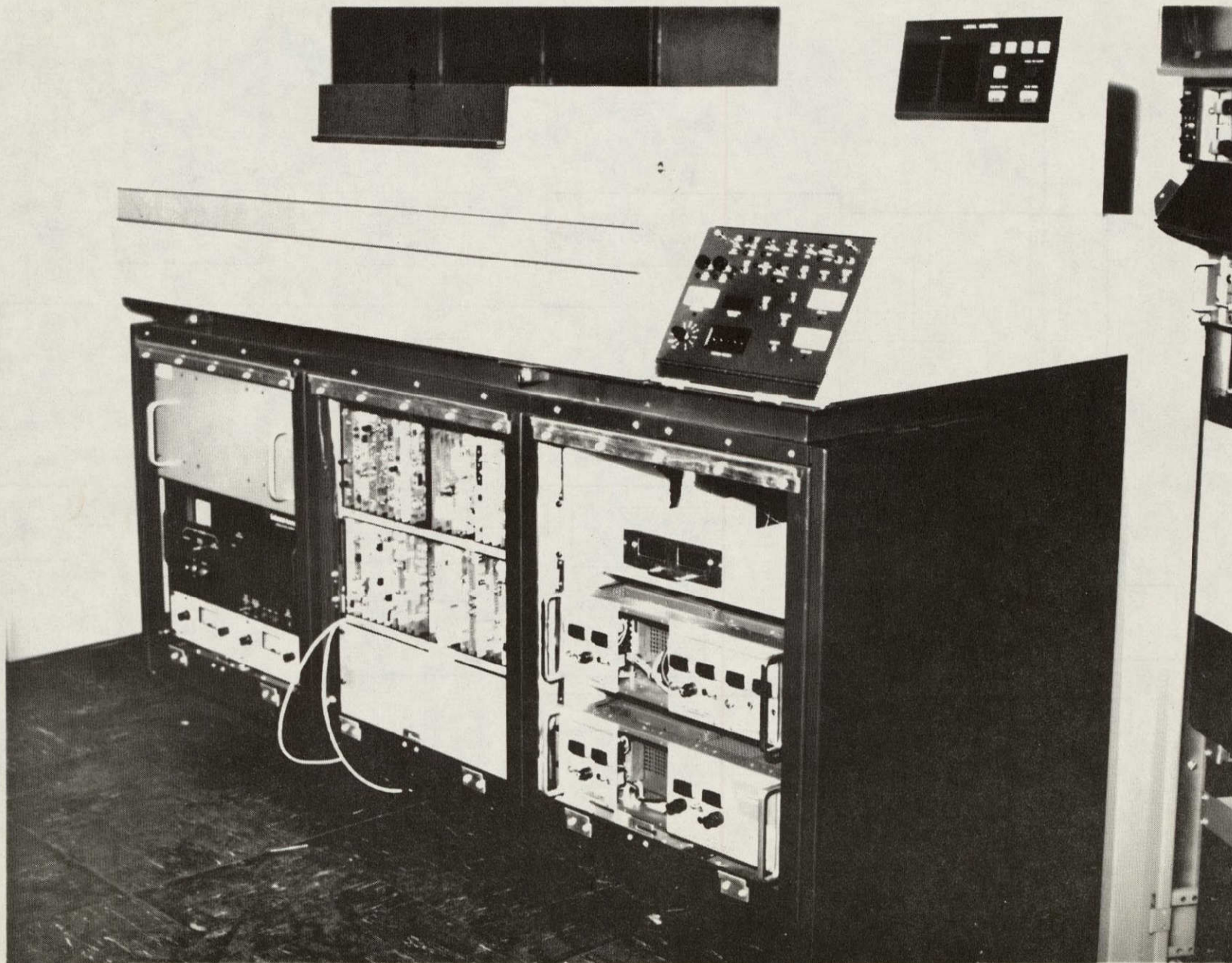

Figure 5-3. Engineering Model of RCA OD System.

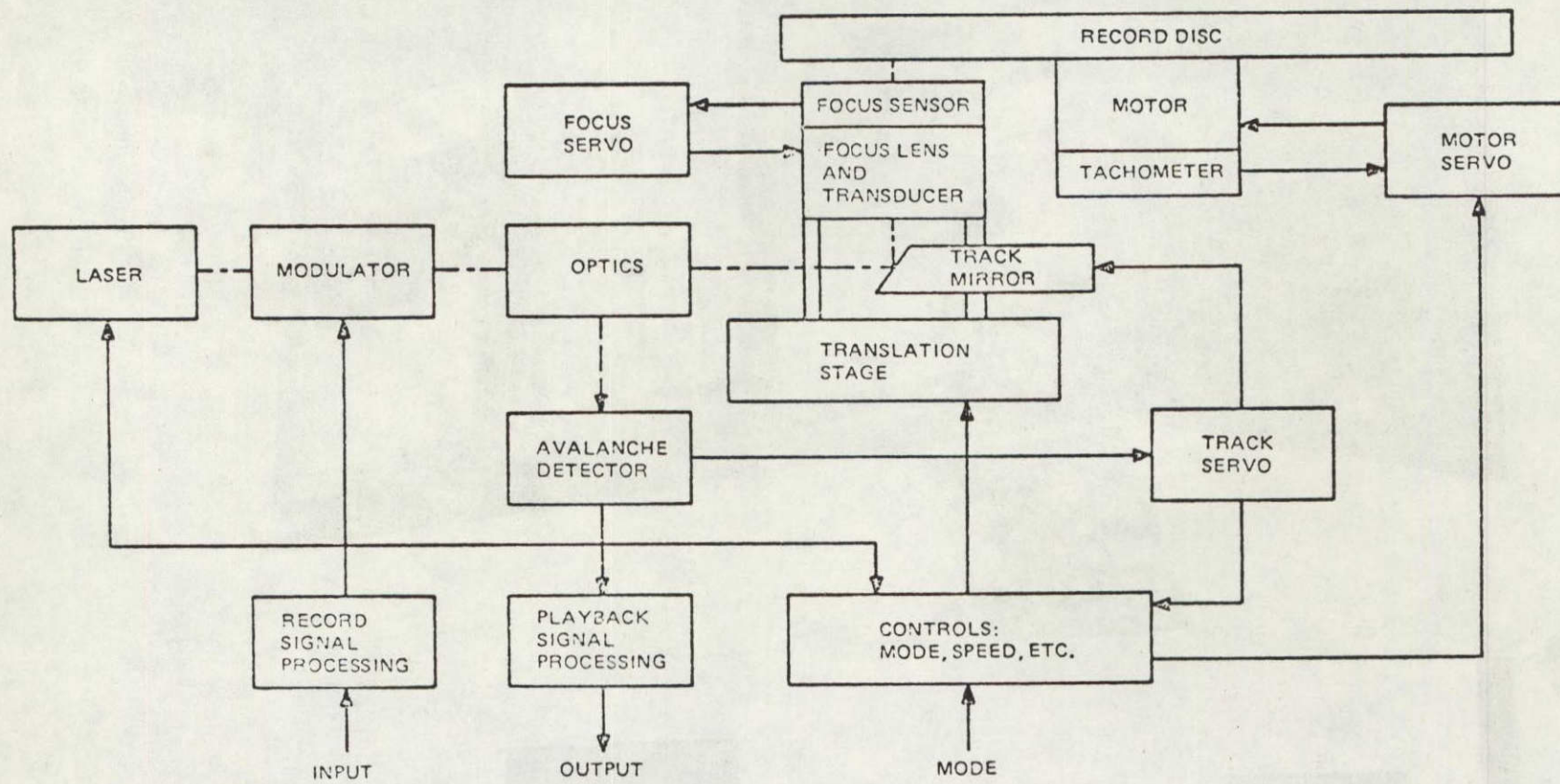

Figure 5-4. RCA Optical Disc System

The next step in the signal processing is to add in error detection and correction information. This step is most important in digital recording systems where bit error rates (BER) of up to 10^{-7} are desired. Analog video systems are inherently redundant in information content and do not require such a low BER. Consequently, EDAC is not usually required in video systems although some form of dropout compensation is commonly employed in such systems.

The next step in the signal processing is to encode the information for recording onto the OD. A number of encoding formats have been developed which should be examined for applicability to the OD system. Some of these require the addition of timing information to ensure proper decoding upon playback. The encoding portion of the system can also be set up to feed the data into the disc on a number of parallel tracks. The number of tracks used here can be different than that used in the demultiplexing and EDAC part of the signal processing.

Retrieving information recorded on a disc involves performing the inverse of the processing used for recording. Information read out of the tracks is first decoded to yield the base input information with EDAC bits. Timing information obtained during playback is fed back to the disc drive to adjust rotational speed for optimum readout. The EDAC circuitry checks the information out of the decoder and corrects the errors within the capability of the EDAC code. Finally, the signals out of the EDAC circuitry are stripped of the EDAC bits and fed to the multiplexer for recombination into the original input data format.

This basic configuration is applicable to both analog and digital recording; the particular portions of the system which are selected depend upon the desired performance characteristics.

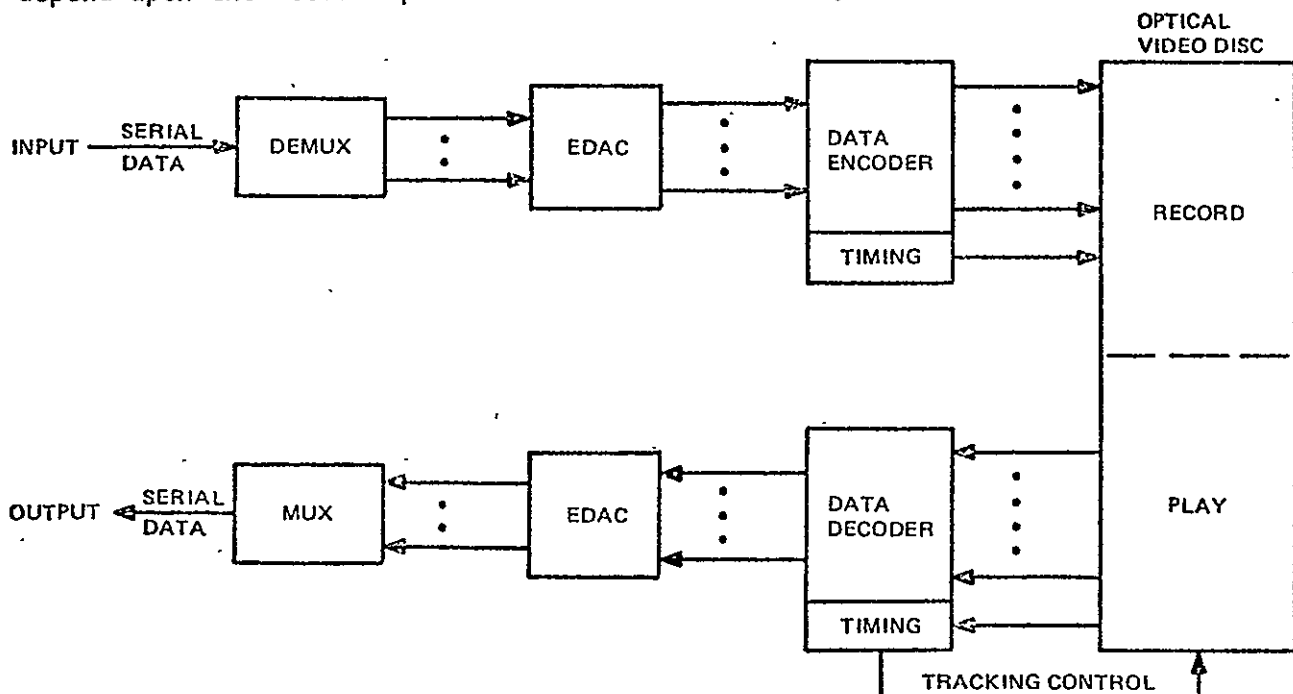

Figure 5-5. OD Record/Reproduce Signal Processing

5.8.2 Optical Disc Recording Characteristics

CAPACITY, MBITS/12" DISC --- 3×10^4 , PROJECTED 6×10^4 (2 SIDES)
TRANSFER RATE, MBITS/SEC. --- 20 PROJECTED 200
FREQUENCY RESPONSE, MHZ --- 0 TO 35, PROJECTED 100
BASIC ERROR RATE --- 10^{-5} , 10^{-8} WITH ERROR CORRECTION
SIGNAL TO NOISE RATIO --- 10^5
ACCESS TIME --- .1 SEC. + DISC LOADING TIME
ANALOG AND/OR DIGITAL DATA STORAGE

5.8.3 Optical Disc Technology Status

HEAVILY SUPPORTED DEVELOPMENT EFFORT BY A FEW
COMPANIES FOR COMMERCIAL APPLICATION
DEMONSTRATION SYSTEMS AVAILABLE
FLEXIBLE THIN DISC MEDIUM
2 SIDE RECORDING
ANALOG & DIGITAL DATA INTERMIXED
NON CONTACT (OPTICAL) RECORDING & PLAY BACK
NO EXTENSIVE HISTORY ON MEDIUM LIFE -- OD'S CAN BE
MADE INERT IN A REASONABLE STORAGE ENVIRONMENT
HIGH RESOLUTION SERVO CONTROL SYSTEM REQUIRED
DISC COST --- \$10

5.8.4 Optical Disc Technology Application to Archival Data Storage

ARCHIVAL STORAGE CAPACITY GOAL ---- 5×10^{14} BITS
FOR 3×10^{10} BITS/DISC (SINGLESIDE), THE SYSTEM
REQUIRES 1.67×10^4 DISCS
FOR 1/4" WIDTH/STORED DISC AND 5 ROWS OF STORAGE
(1/4 X 14 X 14), THE SYSTEM REQUIRES 18 FT². (1.7M²)
ARCHIVAL SPACE REQUIREMENT GOAL --- 100M² (1076 FT²)
THE STORAGE MEDIUM COST, AT \$10/DISC IS \$167,000

Development Effort is Required to Meet the Archival Data Storage
System Goals as Defined. This Development Would Improve The
Capability for:

FLEXIBLE & RIGID MEDIUM MATERIALS
2 SIDE RECORDING
MULTI-LAYER RECORDING
STORAGE CAPACITY, 10^{11} BITS/12" DISC

ORIGINAL PAGE IS
OF POOR QUALITY

The Optical Disc Technology is Recommended for Consideration for
an Archival Data Storage System Required for 1983 Implementation

TECHNOLOGY	RECOMMENDED		REASONS
	YES	NO	
ELECTRON BEAM		X	HIGH COST, EXCESSIVE PWR. & SPACE REQUIREMENTS $\$10^{11}$ 10^6 KW 10^7 FT ³
MAG. BUBBLE		X	HIGH COST, EXCESSIVE PWR. & SPACE REQUIREMENTS $\$10^{12}$,5 X 10^6 KW 8 X 10^4 M ²
MAG DISC		X	HIGH COST, CPU REQUIRED, EXCESSIVE SPACE REQUIREMENTS $\$2.5 \times 10^{10}$ 7 X 10^3 M ²
LONGITUDINAL HDT		X	MEETS ALL SYSTEMS' NEEDS, SYSTEM HDWR DEMONSTRATED, LOW RISK DEVELOPMENT EFFORT REQUIRED
TRANSVERSE HDT	X		MEETS MOST SYSTEMS' NEEDS, SYSTEM HDWR AVAILABLE VERY LOW RISK DEVELOPMENT EFFORT REQUIRED
OPTICAL FILM		X	SPECIAL HANDLING REQUIRED, LIMITED TECHNOLOGY BKGND. VERY HIGH RISK DEVELOPMENT REQUIRED
OPTICAL DISC	X		MEETS MOST SYSTEMS' NEEDS, SYSTEM HDWR DEMONSTRATED LOW RISK DEVELOPMENT EFFORT REQUIRED

FIGURE 5 - 6

PRELIMINARY TRADE-OFF CONCLUSIONS

SECTION 6

TRANSVERSE HIGH DENSITY TAPE & OPTICAL DISC TRADE-OFF

6. 1. GENERAL

A Trade-Off study between the transverse high density tape (THDT), the optical disc (OD) technologies was conducted. The criterion for the Trade-Off was the following Archival System requirements:

SYSTEM CONFIGURATION	MIN.	GOAL	MAX.
STORAGE CAPACITY, BITS	10^{14}	5×10^{14}	10^{15}
TRANSFER RATES, MBITS/SEC.	50	120	300
TRANSFER RATE RANGE	10:1	50:1	---
ACCESS TIME, SEC.	200	100	50
ERROR RATE	10^{-7}	10^{-8}	---
SPACE REQUIREMENTS, M ²	----	100	---

For each of the above requirements, an assessment of the risk involved in achieving the Archival System configuration goal was made for both of the technologies. The following are the risk levels and a definition of each:

RISK LEVEL	DEFINITION
I NO RISK	<ul style="list-style-type: none"> ● SYSTEMS AND/OR HARDWARE AVAILABLE AT PRESENT
II LOW RISK	<ul style="list-style-type: none"> ● NO DEVELOPMENT REQUIRED ● TECHNOLOGY EXISTS
III MEDIUM RISK	<ul style="list-style-type: none"> ● HARDWARE SYSTEMS HAVE BEEN DEMONSTRATED ● FURTHER ADVANCES IN TECHNOLOGY REQUIRED ● SOME SYSTEM ELEMENTS HAVE BEEN DEMONSTRATED
IV HIGH RISK	<ul style="list-style-type: none"> ● HARDWARE DEVELOPMENT REQUIRED ● ADVANCES IN THE STATE-OF-THE-ART REQUIRED ● NO HARDWARE OR SYSTEMS AVAILABLE AT PRESENT ● NO DEMONSTRATION OF CAPABILITIES HAVE BEEN MADE

In addition, system parameters were derived for channel utilization and volumetric packing density. Operational parameters such as failure rates, difficulty of repair and sensity of the device or storage medium to the environment were compared for both of the technologies.

An Archival Data Storage System design concept has been formulated. A block diagram of the system as well as examples of the system implemented with each of the technologies is presented. Parameters considered essential for operational considerations, data base management configuration considerations and Archival System design considerations were formulated.

Development requirements are defined for improving the capabilities of both the transverse high density tape and optical disc units to meet the Archival Data Storage System's requirement goal for the early 1980's implementation.

The overall conclusions of the Trade-Off study shows that the transverse high density tape technology offers a low risk development approach to meet the Archival Data Storage System requirements. A minimum configuration system is implementable using existing hardware. However, the operational requirements are not satisfied in the best way possible because of the large data file size and the resulting slow data access. The optical disc technology offers ideal characteristics for the operational requirements by its fast data access capability, non-contact read-write operations and its capability for easily accommodating semi-automatic loading and sequencing of data files. However, the optical disc technology offers a higher risk development approach to meet the Archival Data Storage System requirements. There is no history on medium life and very little hardware has been demonstrated.

6.2 TECHNOLOGIES TRADE-OFF

6.2.1 ARCHIVAL STORAGE CAPACITY

ARCHIVE REQUIREMENT

CONFIGURATION	MIN.	GOAL	MAX.
NO. OF BITS	10^{14}	5×10^{14}	10^{15}

Reels of 2" Tape	PRESENTLY ACHIEVABLE				TRANSVERSE HDT
	14"D	208	1042	2084	
	10-1/2"D	416	2084	4168	
	PROJECTED 1980'S				
	14"D	104	512	1042	
	10-1/2"D	208	1024	2084	

No. of 12" Discs	PRESENTLY ACHIEVABLE	3300	16700	33400	*OPTICAL DISC
	(1 SIDE 2" TRACK)				
	PROJECTED 1980'S	1000	5000	10000	
	(2 SIDE 4" TRACK)				

*EXTRAPOLATED FROM PRESENT ANALOG CAPABILITY

ORIGINAL PAGE IS
OF POOR QUALITY

6.2.2 STORAGE CAPACITY RISK ASSESSMENT

ARCHIVE REQUIREMENT GOAL --- 5×10^{14} BITS IN $100M^2$

TRANSVERSE HDT

2×10^6 BITS/IN²,
2" WIDE TAPE

REEL D	FT./REEL	BITS REEL X 10^{11}	REELS/ 5×10^{14} BITS	FLOOR SPACE M ²
14	9600	4.8	1042	25
12	7200	3.6	1389	33
10-1/2	4800	2.4	2084	50
8	2400	1.2	4168	100
PRODUCTS ON THE MARKET WITH THIS CAPABILITY --- RCA VERSABIT				RISK LEVEL I

OPTICAL DISC

10^9 BITS/IN²,
1 SIDE RECORDING

DISC D	RECORDING AREA	BITS DISC X 10^{11}	DSCS/ 5×10^{14} BITS	FLOOR SPACE M ²
12	Annular Ring 2"	.3	16700	25

RISK AREAS FOR INCREASED DISC STORAGE CAPACITY IN ORDER TO REDUCE NO. OF DISCS

MULTIPLE TRACK RECORDING	RISK LEVEL IV
2 SIDED RECORDING	RISK LEVEL III
INCREASE OF RECORDING AREA	RISK LEVEL III

6.2.3 ARCHIVAL TRANSFER RATES

ARCHIVE REQUIREMENT

CONFIGURATION	MIN.	GOAL	MAX.
MEGABITS/SEC.	50	120	300

PRESENTLY ACHIEVABLE		40	
PROJECTED 1980'S		100	

TRANSVERSE HDT

PRESENTLY ACHIEVABLE		40	
PROJECTED 1980'S		200	

OPTICAL DISC*

*EXTRAPOLATED FROM PRESENT ANLOG CAPABILITY OF 20 MHZ.

ORIGINAL PAGE IS
OF POOR QUALITY

6.2.4 TRANSFER RATES RISK ASSESSMENT

ARCHIVE REQUIREMENT GOAL -----120 MB/S

TRANSVERSE HDT

40 MB/S

RISK AREAS FOR INCREASED TRANSFER RATE

INCREASED PACKING DENSITY	
(BITS/UNIT TRACK LENGTH	RISK LEVEL III
INCREASED NO. OF HEADS/WHEEL	RISK LEVEL III
HIGHER HEAD WHEEL SPEED	RISK LEVEL II (a)

- (a) HEAD wheel speed increases from 152 RPS to 305 RPS have been successfully demonstrated on the RCA Versabit

NOTE: HELICAL SCAN SYSTEM BEING DEVELOPED FOR

>80 MB/S USING 1 IN. TAPE

*OPTICAL DISC

40 MB/S

RISK AREAS FOR INCREASED TRANSFER RATE

HIGHER DISC SPEED	RISK LEVEL III
MULTIPLE TRACK RECORDING	RISK LEVEL IV
MULTIPLE HEAD DESIGN	RISK LEVEL III
RECORD & PLAYBACK DIGITAL DATA	RISK LEVEL II TO III

*EXTRAPOLATED FROM PRESENT ANALOG CAPABILITY OF 20 MHZ.

6. 2. 5. ARCHIVAL TRANSFER RATE RANGE

ARCHIVE REQUIREMENT

CONFIGURATION	MIN.	GOAL	MAX.
RANGE RATIO	10:1	50:1	---
PRESENTLY ACHIEVABLE	18:1 40 TO 2.2 MB/S 5 RANGES		TRANSVERSE HDT
PROJECTED (1980's)	64:1 100 TO 1.5 MB/S 8 RANGES		
PRESENTLY ACHIEVABLE	18:1		OPTICAL DISC
PROJECTED 1980's	50:1		

ORIGINAL PAGE IS
OF POOR QUALITY

6.2.6 TRANSFER RATE RANGE RISK ASSESSMENT

ARCHIVE REQUIREMENT GOAL --- 50:1

TRANSVERSE HDT

18:1

RISK AREAS FOR INCREASED TRANSFER RATE RANGE

ADDITIONAL RANGES (EACH RANGE 2:1 RATIO)	RISK LEVEL II (a)
WIDER DYNAMIC RANGE FOR ELECTRONICS	RISK LEVEL II (a)
WIDER DYNAMIC RANGE FOR MECHANISM	RISK LEVEL II (a)
MORE COMPLEX TIMING & CONTROL FUNCTIONS	RISK LEVEL III

- (a) ADDITIONAL RANGES (6) AND WIDER DYNAMIC RANGES (40:1) HAVE SUCCESSFULLY BEEN DEMONSTRATED ON THE RCA VERSABIT.

OPTICAL DISC

18:1

RISK AREA FOR INCREASED TRANSFER RATE RANGE

DISC SPEED CONTROL & REGULATION	RISK LEVEL III
MULTISPEED SERVO SYSTEM	RISK LEVEL III
WIDER DYNAMIC RANGE FOR ELECTRONICS	RISK LEVEL III
WIDER DYNAMIC RANGE FOR MECHANISM	RISK LEVEL III
MORE COMPLEX TIMING & CONTROL FUNCTIONS	RISK LEVEL III

6. 2. 7. ARCHIVAL ACCESS TIME

ARCHIVE REQUIREMENT

CONFIGURATION	MIN.	GOAL	MAX.
SEC.	200	100	50

Worst Case Access Requirements
(From Data Request to Storage of File)

_____ 10^9 BITS/RECORD _____
_____ 2 ADJACENT RECORDS/REQUEST _____

ORIGINAL PAGE IS
OF POOR QUALITY

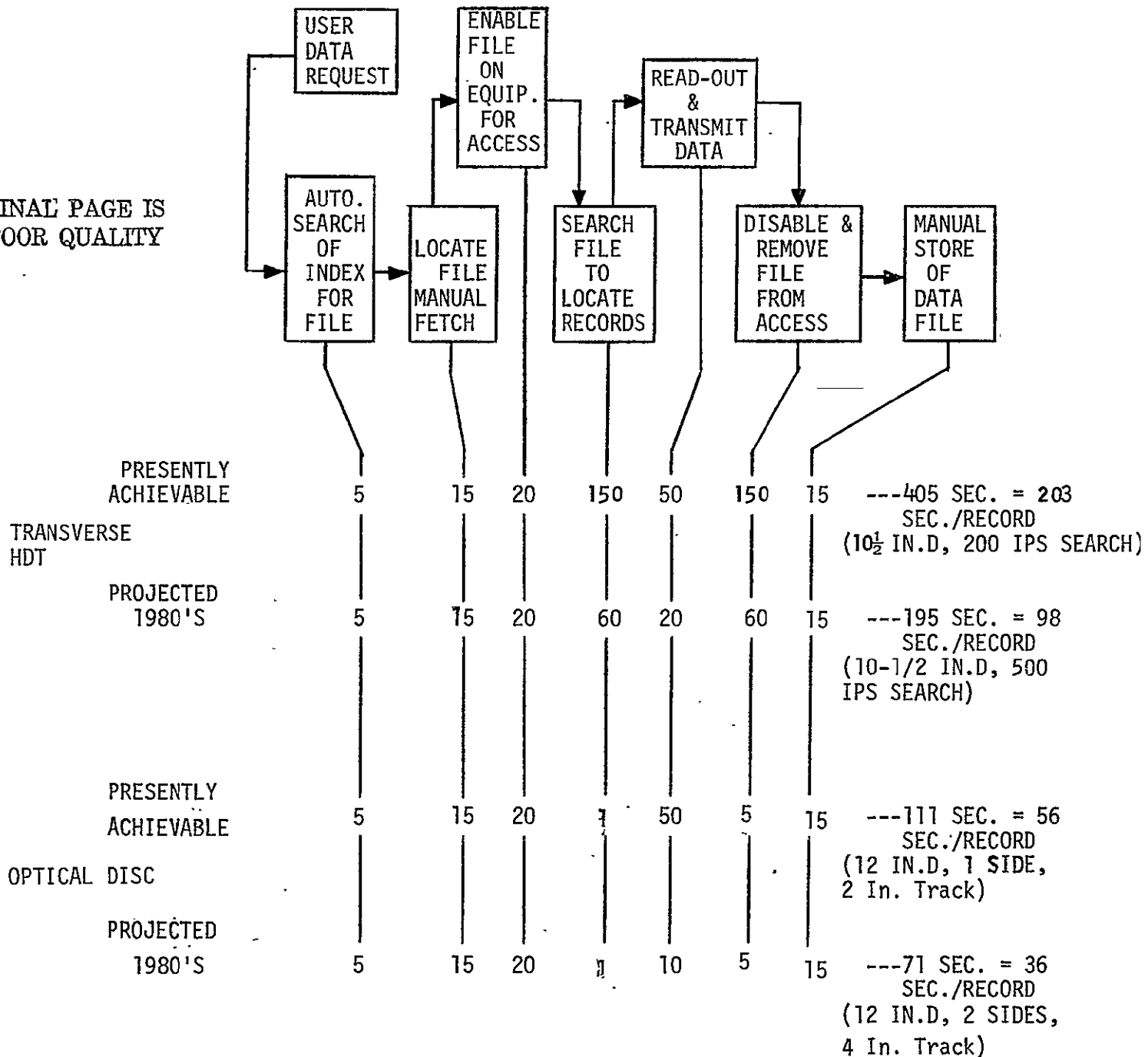

6. 2. 7. 1 HDT ACCESS TIME

Influencing Factors for Determining Ideal Tape Search Speed to Meet Archival Requirements

ACCESS TIME IS FOR WORST CASE REQUIREMENTS.
(FROM DATA REQUEST TO STORAGE OF FILE).

10^9 BITS/RECORD
2 ADJACENT RECORDS/REQUEST

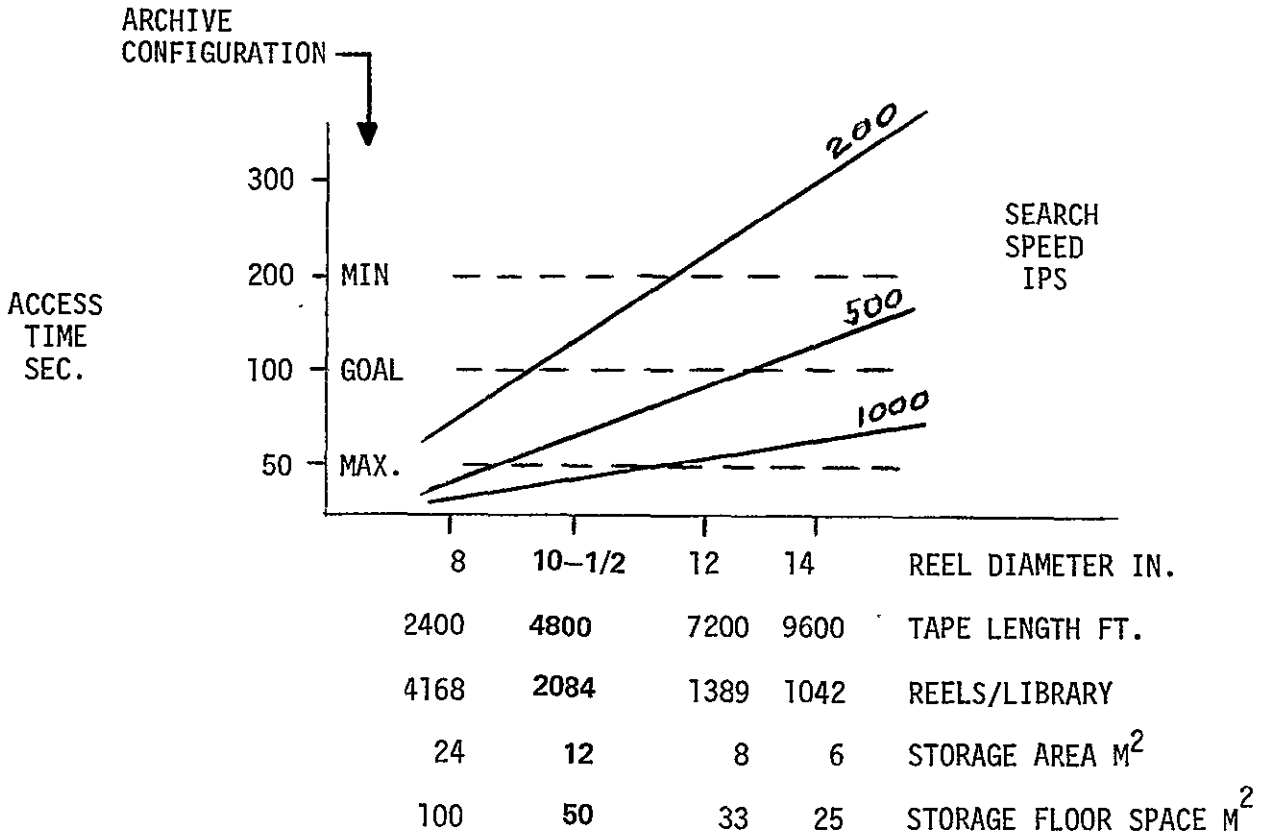

6. 2. 8 ACCESS TIME RISK ASSESSMENT

ARCHIVE REQUIREMENT GOAL -----100 SEC.

WORST CASE ACCESS REQUIREMENTS

(FROM DATA REQUEST TO STORAGE OF FILE)

10^9 BITS/RECORD

2 ADJACENT RECORDS/REQUEST

TRANSVERSE HDT

353 SEC/RECORD

14" D REELS, 9600 FR., 4.8×10^{11} BITS/REEL, 200 IPS SEARCH

RISK AREAS FOR REDUCED ACCESS TIME

HIGHER SEARCH SPEED	RISK LEVEL II(a)
MORE SOPHISTICATED SERVO CONTROL SYSTEM	RISK LEVEL II(a)
SEARCH TRACK WITH WIDE DYNAMIC RANGE READ CAPABILITIES	RISK LEVEL II(a)
BETTER TAPE HANDLING CHARACTERISTICS (VACUUM BINS)	RISK LEVEL III(b)
FASTER START/STOP CAPABILITIES	RISK LEVEL II(b)
SMALLER REEL SIZE	RISK LEVEL I(b)

- (a) 100 IPS Servo Controlled Tape Search Capabilities with side Dynamic Range Read Capabilities Demonstrated on the Ampex Terabit.
- (b) Capabilities of Ampex Terabit include vacuum bin tape handling for faster start/stop operations and 10-1/2 in. Reels

OPTICAL DISC

56 SEC/RECORD

12" D. DISC, 3×10^{10} BITS/DISC

FAST ACCESS DEMONSTRATED ON RCA OPTICAL DISC SYSTEM. RISK LEVEL I

ORIGINAL PAGE IS
OF POOR QUALITY

6. 2. 9. ARCHIVAL ERROR RATE

ARCHIVE REQUIREMENT

CONFIGURATION	MIN	GOAL	MAX
ERROR RATE	10 ⁻⁷	10 ⁻⁸	---

PRESENTLY ACHIEVABLE	10 ⁻⁸ WITH EDAC		
PROJECTED 1980's	10 ⁻¹¹ WITH EDAC & REDUNDANCY		

TRANSVERSE
HDT

PRESENTLY ACHIEVABLE	10 ⁻⁸ *		
PROJECTED 1980's	WITH EDAC 10 ⁻¹¹ WITH EDAC & REDUNDANCY		

OPTICAL
DISC

* EXTRAPOLATED FROM PRESENT ANALOG CAPABILITY OF 10⁻⁵ & SNR = 50 DB

6. 2 . 10. ERROR RATE RISK ASSESSMENT

ARCHIVE REQUIREMENT GOAL ----- 10^{-8}

TRANSVERSE HDT

PRESENT CAPABILITIES

BASIC BER ---- 10^{-6}	RISK LEVEL I(a)
WITH EDAC ---- 10^{-8}	RISK LEVEL I(a)

- (a) EDAC FOR BURST ERROR CORRECTION (SINGLE 4 BIT BURST EDAC) BUILT & TESTED FOR RCA VERSABIT

OPTICAL DISC

PRESENT CAPABILITIES*

BASIC BER ---- 10^{-5}	RISK LEVEL II(a)
WITH EDAC ---- 10^{-8}	RISK LEVEL III

- (a) ANALOG BER OF 10^{-5} DEMONSTRATED FOR SNR = 50 DB ON RCA OPTICAL DISC SYSTEM

*EXTRAPOLATED FROM PRESENT ANALOG CAPABILITY & SNR = 50 DB

ORIGINAL PAGE IS
OF POOR QUALITY

6. 2. 11. ARCHIVAL FLOOR SPACE

ARCHIVE REQUIREMENT

ENTIRE SYSTEM	GOAL
FLOOR SPACE - M ²	100
PRESENTLY ACHIEVABLE	ARCHIVE (TAPE) STORAGE - 50 M ² EQUIPMENT FLOOR SPACE - 10 M ² Total - 60 M ² (2 X 10 ⁶ BITS/IN ²)
PROJECTED 1980's	ARCHIVE (TAPE) STORAGE - 25 M ² EQUIPMENT FLOOR SPACE - 10 M ² Total - 35 M ² (4 X 10 ⁶ BITS/IN ²)
PRESENTLY ACHIEVABLE	ARCHIVE (DISC) STORAGE - 25 M ² EQUIPMENT FLOOR SPACE - 12 M ² Total - 37 M ² (1 SIDE, 3 X 10 ¹⁰ BITS/DISC)
PROJECTED 1980's	ARCHIVE (DISC) STORAGE - 8 M ² EQUIPMENT FLOOR SPACE - 12 M ² Total - 20 M ² (2 SIDE, 10 ¹¹ BITS/DISC)

TRANSVERSE
HDT

OPTICAL
DISC

6. 3. DERIVED ARCHIVAL SYSTEM PARAMETERS

System parameters are derived for the transverse high density tape and the optical disc technologies relative to the Archival Data Storage System requirements. The derived parameters include channel utilization and real volumetric packing density.

6. 3. 1. CHANNEL UTILIZATION

TRANSVERSE HDT - Basically a single or dual channel device. Parallel input/output data channels are fully buffered and data is transferred in serial form between the tape and the buffers. Therefore, the channel utilization for this device is inherently 100%. Using this device, channel utilization becomes a system parameter and is dependent upon the transfer rate of the device and the system operational specifications for the Archival Data Storage System.

QUADRUPLEX - 1 CHANNEL OCTAPLEX - 2 CHANNEL MULTI-CHANNEL PARALLEL INPUTS & OUTPUTS FULLY BUFFERED INPUT & OUTPUT INTERFACE SERIAL DATA RATE BETWEEN TAPE & BUFFERS

OPTICAL DISC - Basically a single channel-device with good potential for simultaneous multi-channel capability. Parallel input/output data channels are fully buffered and data is transferred serially between the disc and the multi-channel input/output data buffers. Therefore, this device has an inherent channel utilization of 100%. Using this device in its present configuration, channel utilization becomes a system parameter and is dependent upon the device transfer rate and the system operational specifications for the Archival Data Storage System.

SINGLE CHANNEL TWO HEADS - ONE READ/WRITE, ONE READ ONLY SERIAL INPUT/OUTPUT DATA RATE MULTI-TRACK CONFIGURATION

ORIGINAL PAGE IS
OF POOR QUALITY

6. 3. 2. REAL VOLUMETRIC PACKING DENSITY

TRAVERSE HDT

$$\text{VOLUMETRIC DENSITY} = \frac{\text{AREA DENSITY}}{\text{THICKNESS}}$$

AREA DENSITY (BITS/IN ²)	TAPE THICKNESS (IN.)	VOLUMETRIC DENSITY (BITS/IN. ³)
10 ⁶	1.25 X 10 ⁻³	8 X 10 ⁸
2 X 10 ⁶	1.25 X 10 ⁻³	16 X 10 ⁸
2 X 10 ⁶	1.25 X 10 ⁻³	32 X 10 ⁸

OPTICAL DISC

$$\text{VOLUMETRIC DENSITY} = \frac{\text{AREA DENSITY}}{\text{DISC THICKNESS}} \times \text{NO. OF SIDES}$$

AREA DENSITY (BITS/IN ²)	DISC THICKNESS (IN.)	NO. OF SIDES	VOLUMETRIC DENSITY (BITS/IN. ³)
10 ⁹	.125	1	8 X 10 ⁹
10 ⁹	.125	2	16 X 10 ⁹

6. 4. OPERATIONAL PARAMETERS

Operational parameters such as expected failure rates, difficulty of repair and sensitivity of the device or storage medium to the environment are compared for both the traverse high density tape and optical disc technologies.

6. 4. 1. EXPECTED FAILURE RATE

TRANSVERSE HDT --- The mechanisms used in the tape transports are similar to those in use for at least the past 10 years. A good history on the life and continued improvement of these mechanisms has improved the reliability considerably. The circuitry, both analog and digital, which is employed is based on standard well developed techniques to ensure good reliability.

MTBF	≥ 2000 HRS.
RELIABILITY	> 20 YEARS OF USEFUL LIFE
HEADLIFE	> 600 HRS.

OPTICAL DISC ---The mechanisms used in the optical disc devices are not all that different from those employed in magnetic disc units and elsewhere. The continued improvement over the years of these mechanisms has made them very reliable. The circuitry used in the optical disc devices is not unique and employs standard components and proven design techniques. Therefore, although the optical disc device does not have much of a history, it is expected to have reliability characteristics comparable to those for the magnetic tape devices.

MTBF	2000 HRS. (EST.)
RELIABILITY	NO HISTORICAL DATA, EXPECTED TO PROVIDE > 20 YEARS OF USEFUL LIFE.

6.4. 2. DIFFICULTY OF REPAIR

TRANSVERSE HDT ----- The tape transports and associated electronics are constructed from standard type parts and the assemblies and circuits are well established and in general are thoroughly understood by service personnel.

MTTR	< 1 HR. USING RECOMMENDED SPARES
MAINTAINABILITY	- NO SPECIAL TOOLS REQUIRED, MAINTAINED BY ELECTRONIC TECH.

ORIGINAL PAGE IS
OF POOR QUALITY

OPTICAL DISC -----Although the presently constructed units are essentially configured as laboratory models, it is expected that the production versions will be similar in construction technique and parts usage as other related devices such as magnetic tape units and magnetic disc units.

MTTR	< 1 HR. (EST.) USING RECOMMENDED SPARES
MAINTAINABILITY -	NO SPECIAL TOOL REQUIRED, MAINTAINED BY ELECTRONIC TECH.

6.4. 3. SENSITY OF THE DEVICE OR STORAGE MEDIUM TO THE ENVIRONMENT

TRANSVERSE HDT ---Both the equipment and the recording medium must be considered for the environmental factors. An equipment storage environment is generally acceptable over an extremely wide range of temperature and humidity conditions provided that they are non-condensating. The operating environmental conditions are more restrictive and the limits are dictated by the operating environment required by the recording medium. Typically, the equipment and the medium should be stabilized within these limits for at least 24 hours prior to recording data or playing back previously recorded data. The storage environment for the medium is the most restrictive. Long term history on magnetic tape storage substantiates the fact that, if the storage environment for magnetic tape is maintained within the narrow recommended limits, the life of the medium and the integrity of the stored data could virtually be extended indefinitely provided proper physical handling precautions are observed.

EQUIPMENT:	OPERATING LIMITS	NON OPERATING LIMITS
	TEMPERATURE 5 ⁰ TO 40 ⁰ C	-20 TO + 71 ⁰ C
	HUMIDITY 20% TO 70 %	0 TO 100%
MEDIUM:	IDEAL FOR ARCHIVAL STORAGE	
	TEMPERATURE 18.3 ⁰ TO 23.9 ⁰ C	
	HUMIDITY 45% TO 55%	

OPTICAL DISC ----Since the existing equipment is not in final production configuration and the recording medium has not been standardized or finalized, the environmental considerations must be extrapolated. The equipment is expected to be similar in construction and operation as other electronic/electro-mechanical equipment such as magnetic tape and magnetic disc units. Therefore, the equipment operating and non operating environmental limits should fit within those required for the magnetic tape units. The materials being considered and currently being used for the recording medium exhibit characteristics of long term storage stability when maintained within the restrictive environmental limits as specified for magnetic tape storage.

EQUIPMENT: (EXPECTED)	OPERATING LIMITS	NON OPERATING LIMITS
	TEMPERATURE 5° TO 40° C HUMIDITY 20% TO 70%	-20° TO 71°C 0 TO 100%
MEDIUM: (ESTIMATED)	SIMILAR TO STORAGE REQUIREMENTS OF MAG. TAPE	
	TEMPERATURE 18.3° TO 23.9°C HUMIDITY 45% TO 55%	

ORIGINAL PAGE IS
OF POOR QUALITY

6. 5. ARCHIVAL DATA STORAGE SYSTEM DESIGN

An Archival Data Storage System design concept has been formulated. Example implemented systems utilizing the transverse high density tape and the optical disc technologies are configured for the data Archive requirements.

6. 5. 1. Archival Data Storage System Configuration

A general system configuration for the Archival Data Storage System is shown in Figure 6 - 1. The major system elements are the administrative command and control system and the data base management system.

Administrative Command and Control System -- Provides operator interface for Archival storage of new input data and Archival retrieval for customer data requests. A microprocessor comprises the heart of this system and provides for automatic control of the data base management system. An index and directory section provides for the up-dated, on-line location of all data stored in the Archival Mass Storage System.

Data Base Management System -- Provides for the data input interfacing and control, the data base storage, and the data output interface and control. The data base storage section consists of the storage/retrieval hardware and equipment, the storage medium and the medium storage facility. The input/output interface and control sections consist of the input/output controllers which interface the input/output data communications and contain the hardware and equipment for channel selection, data buffering and input/output formatting.

6. 5. 2. Archival Data Storage System -- THDT. A system configuration for the Archival Data Storage System employing the transverse high density tape technology is shown in Figure 6 - 2. Some of the characteristics of this system configuration are as follows:

ROOM SIZE --- 100M ²
ARCHIVE (TAPE) STORAGE --- 50M ²
EQUIPMENT FLOOR SPACE --- 10M ²
ARCHIVE STORAGE CAPACITY -- 5 X 10 ¹⁴ BITS (2084 10½" REELS)
THDT #1 --- DATA STORAGE, INPUTS FROM HDTR
THDT #2 --- DATA RETRIEVAL, OUTPUTS TO HDTR
THDT #3 --- DATA RETRIEVAL STAGING, TAPE DECK ONLY, SWITCHABLE WITH THDT #2.
CONTROL CONSOLE --- DATA INDEXING & RETRIEVAL LOCATOR

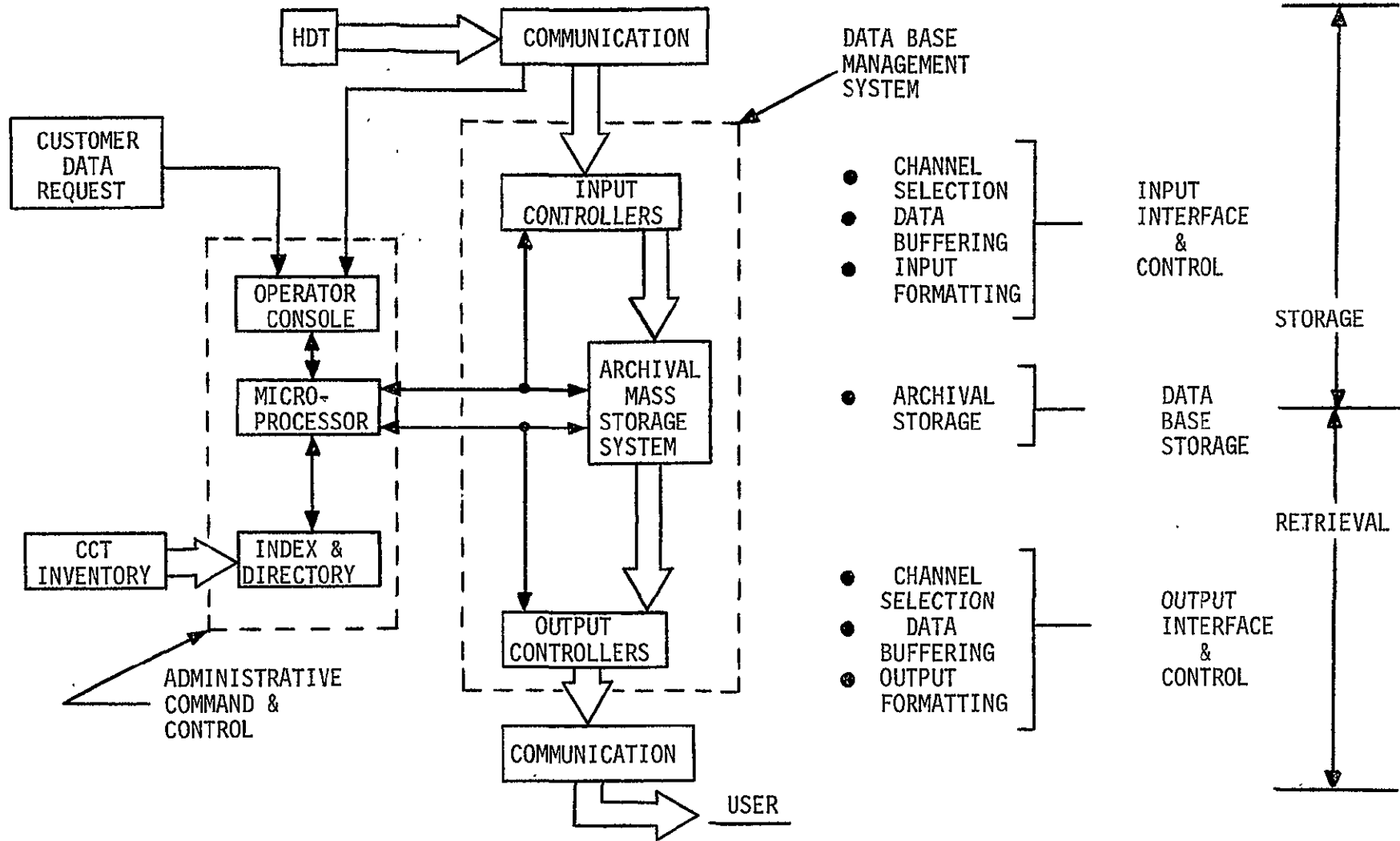

Figure 6 - 1

ARCHIVAL DATA STORAGE SYSTEM

ARCHIVAL STORAGE
FOR 5×10^{14} BITS
(2084 $10\frac{1}{2}$ " REELS)

THDT #3
DATA RETRIEVAL
STAGING

THDT #2
DATA RETRIEVAL

THDT #1
DATA STORAGE

CONTROL CONSOLE
DATA INDEXING &
RETRIEVAL LOCATOR

ROOM
SIZE 2
100 M

6 - 22

FIGURE 6 - 2
ARCHIVAL DATA STORAGE SYSTEM - THDT

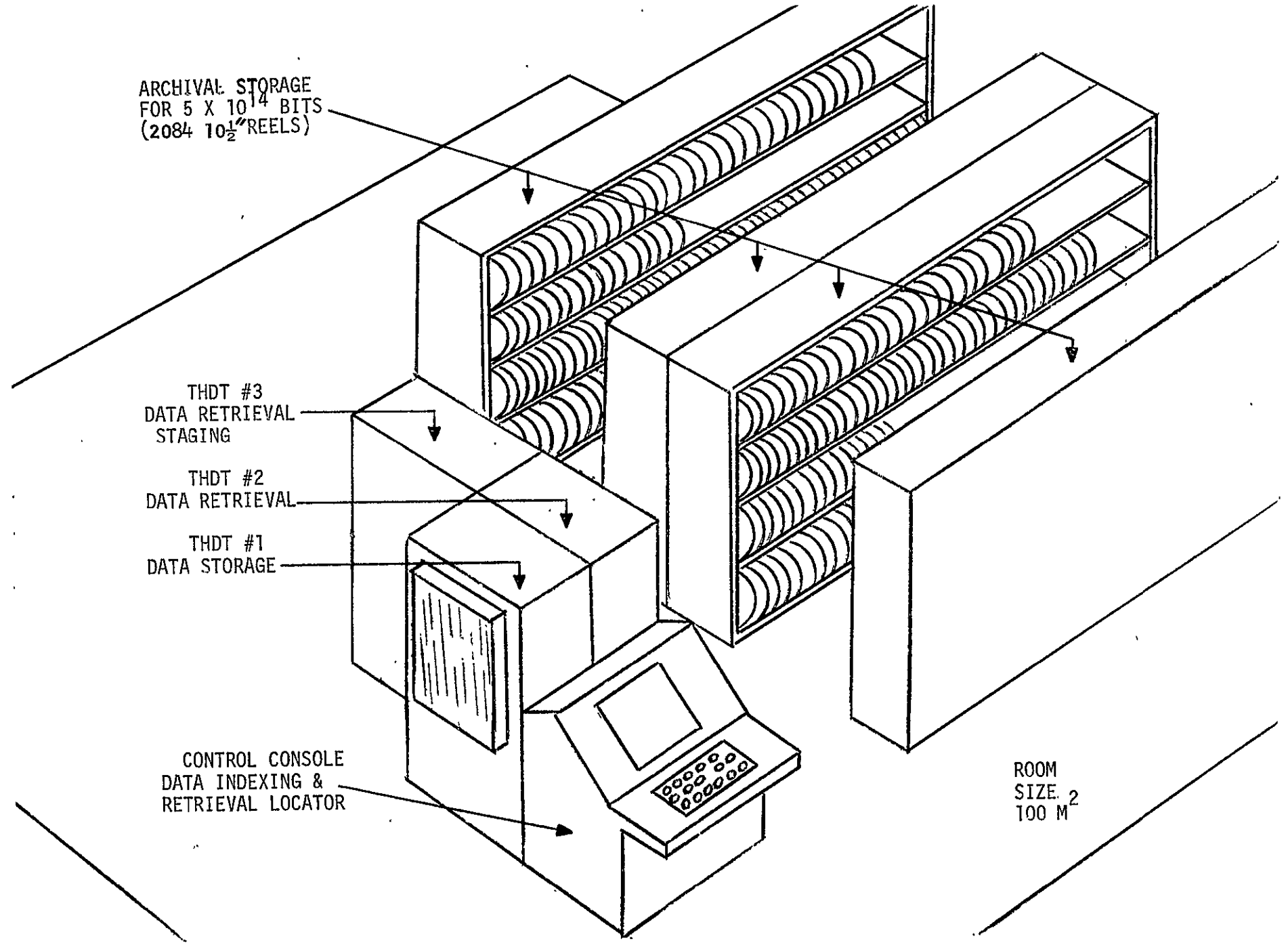

6. 5. 3. Archival Data Storage System --OD. A system configuration for the Archival Data Storage System employing the optical disc technology is shown in Figure 6 - 3. Some of the characteristics of this system configuration are as follows:

ROOM SIZE --- 100 M ²
ARCHIVE (DISC) STORAGE --- 25M ²
EQUIPMENT FLOOR SPACE --- 12M ²
ARCHIVE STORAGE CAPACITY --- 5 X 10 ¹⁴ BITS(1.67 X 10 ⁴ 12" DISCS)
OD #1 --- DATA STORAGE, INPUT FROM HDTR
OD #2 --- DATA RETRIEVAL, OUTPUTS TO HDTR
OD #3 --- DATA RETRIEVAL, STAGING UNIT, SWITCHABLE WITH OD #2
CONTROL CONSOLE --- DATA INDEXING & RETRIEVAL LOCATOR

6. 5. 4. Archival Data Storage System -- Risk Considerations. All elements of the Archival Data Storage system excluding the Archival Mass Storage System elements can be existing, well documented elements of proven design with high reliability characteristics. However, the selection of the technology to implement the Archival Mass Storage System (transverse high density tape or optical disc) will influence the selection, arrangement and interfacing of all other system elements. Therefore, at least the following factors should be given consideration in order to minimize the overall system configuration risks.

DATA BASE MANAGEMENT SYSTEM

INTERFACE & CONTROL CHANNEL SELECTION DATA BUFFERING DATA FORMATTING

ADMINISTRATIVE COMMAND & CONTROL

OPERATOR CONSOLE MICROPROCESSOR CONTROLLER INDEX & DIRECTORY
--

ORIGINAL PAGE IS
OF POOR QUALITY.

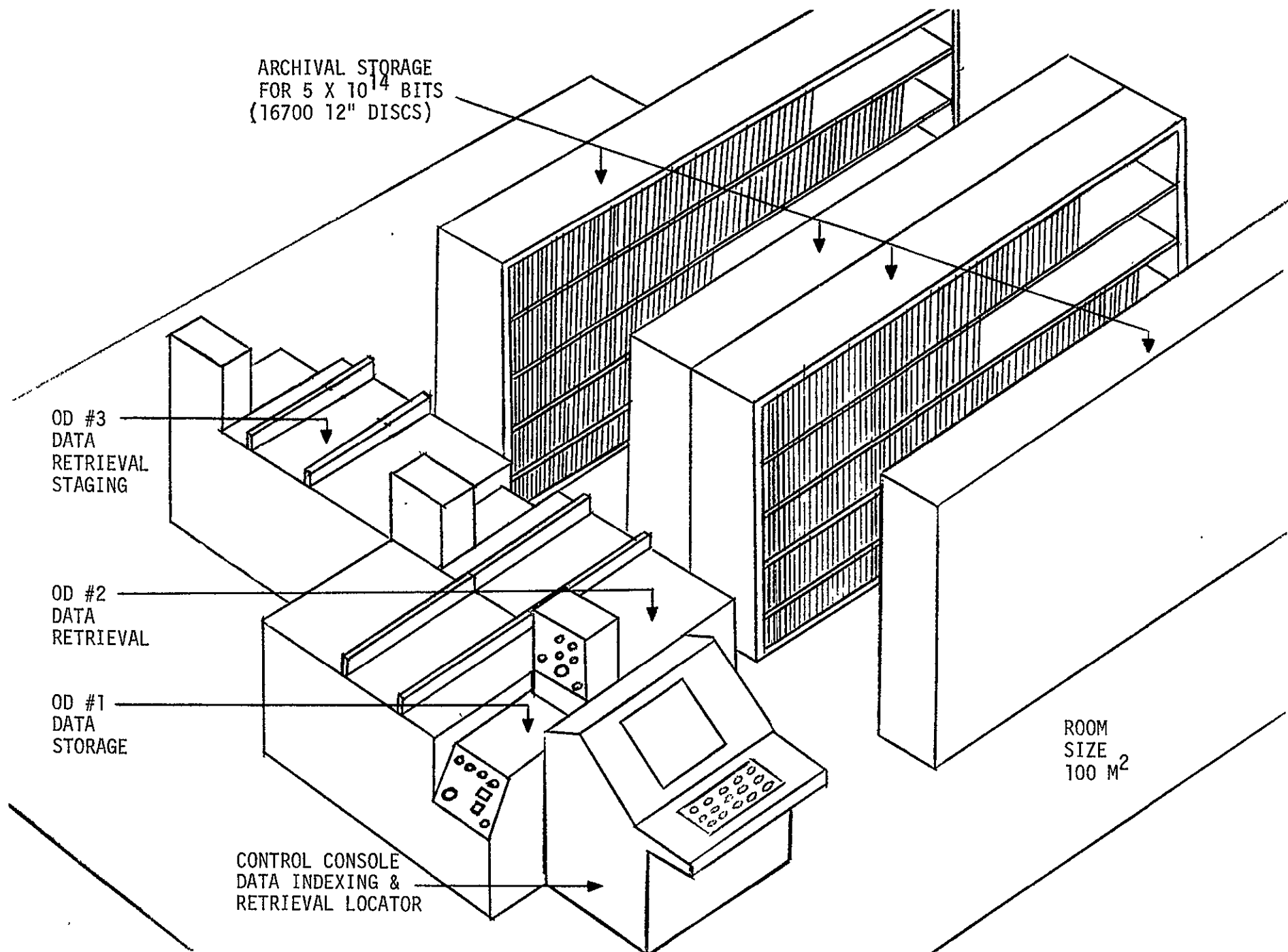

6 - 24

FIGURE 6 - 3
ARCHIVAL DATA STORAGE SYSTEM - OD

6. 6. ARCHIVAL DATA STORAGE SYSTEM CONSIDERATIONS

Prior to finalizing an overall Archival Data Storage System design, the operational mode of the system must be established, the data base management requirements must be formulated and the Archival system design requirements must be specified. Determinations for at least the following considerations must be made.

6. 6. 1. ARCHIVAL OPERATIONAL CONSIDERATIONS

SIMULTANEOUS DATA STORAGE & RETRIEVAL
DATA RETRIEVAL STAGING
MANUAL/AUTOMATIC DATA RETRIEVAL
VARIABLE LENGTH DATA FILES
SIMULTANEOUS MULTIPLE REQUEST SERVICE
DATA RETRIEVAL REQUEST BATCHING

6. 6. 2. ARCHIVE DATA BASE MANAGEMENT CONSIDERATIONS

NUMBERS OF REQUESTS VS. DATA AGE
INTERFILING DATA REQUESTS
STORAGE FORMATTING
HARDWARE/SOFTWARE RELATIONSHIP
INPUT/OUTPUT COMMUNICATIONS INTERFACING
OPERATOR INTERFACE & CONTROL

6. 6. 3. ARCHIVE SYSTEM DESIGN CONSIDERATIONS

NUMBER OF PARALLEL INPUT/OUTPUT CHANNELS
FILE LENGTH VS. ACCESS TIME
FILE LENGTH VS. REQUEST FREQUENCY (DATA AGE)
DATA BUFFERING REQUIREMENTS
CUSTOMER/ARCHIVE INTERFACE
NEW DATA FILE AVAILABILITY

ORIGINAL PAGE IS
OF POOR QUALITY

6. 7. ARCHIVAL DATA STORAGE SYSTEM DEVELOPMENT REQUIREMENTS

In order to meet the Archival Data Storage System requirements goal for implementing a system in the early 1980's, certain development effort would be required for either the transverse high density tape technology or optical disc technology.

6. 7. 1. TRANSVERSE HIGH DENSITY TAPE DEVELOPMENT REQUIREMENTS

Depending upon the overall system design specifications, at least the following areas of development for the transverse high density tape technology are considered important in achieving the system requirements goal.

HIGH SPEED SEARCH CAPABILITIES --- 1000 IPS INCREASED DATA RATE --- 100 MBPS REEL SWITCHING CAPABILITY --- COMMON ELECTRONICA/DUAL DRIVES AUTOMATIC TAPE LOADING CAPABILITY INTERFACE & STAGING ELECTRONICS

6. 7. 2. OPTICAL DISC DEVELOPMENT REQUIREMENTS

Depending upon the overall system design specifications, at least the following areas of development for the optical disc technology are considered important in achieving the system requirements goal.

INCREASED DATA RATE --- 100 MBPS TWO SIDED RECORDING CAPABILITY INCREASED ANNULAR RECORDING AREA --- 4 IN. VARIABLE RPM CAPABILITY --- 50:1 RANGE AUTOMATIC LOADING CAPABILITY INTERFACE & STAGING ELECTRONICS

6. 8 . TRADE-OFF CONCLUSIONS

Based upon this trade-off study between the transverse high density tape technology and the optical disc technology relative to the Archival Data Storage System requirements, the following conclusions can be made. The transverse high density tape requires a lower risk development effort and at least a minimum configuration system is more readily implementable with existing equipment. The optical disc, however, is more amenable to the operational requirements of the Archival Data Storage System; but the overall development required is of a much higher risk. Listed below are some of the salient points of the conclusions.

TRANSVERSE HIGH DENSITY TAPE

LOWER RISK DEVELOPMENT REQUIRED FOR SYSTEM
SYSTEM EASILY IMPLEMENTABLE NOW AT MINIMUM CONFIGURATION
PROVEN HARDWARE AVAILABLE AS A BASE
LONG TERM MEDIUM STORAGE DEMONSTRATED
SLOW DATA ACCESS
DATA FILES NOT AS EASY TO HANDLE

OPTICAL DISC

SOMEWHAT BETTER SUITED TO OPERATIONAL REQUIREMENTS
FAST DATA ACCESS
SEMI AUTOMATIC LOADING & SEQUENCING
NO MECHANICAL CONTACT WITH MEDIUM DURING READ-WRITE
HIGHER RISK DEVELOPMENT REQUIRED FOR SYSTEM
NO HISTORY ON MEDIUM LIFE
LIMITED HARDWARE DEMONSTRATED

SECTION 7

DEVELOPMENT PROGRAM OUTLINE TO DEMONSTRATE FEASIBILITY OF HIGH RISK ITEMS

7. 1. GENERAL

Since both the transverse high density tape and optical disc technologies are significant candidates for a viable approach in achieving an Archival Data Storage System as characterized by Table 2 - 1, a development program to demonstrate feasibility of the high risk items is outlined for each.

7. 2. TRANSVERSE HIGH DENSITY TAPE DEVELOPMENT PROGRAM

The characteristic of the transverse high density tape which is most critical in meeting the requirements for the Archival Data Storage system is the data access time. The factors contributing to the data access time are the loading of the tape, the search of the tape for the data record and the reading and transmitting of the data record. Of these, the most time consuming is the tape search.

The following initial development program outline is proposed to increase the capabilities and demonstrate the feasibility of the transverse high density tape to meet the requirements goal of the Archival Data Storage system to be implemented in the early 1980's.

TAPE SEARCH -- Design a tape search system which will search a file (14 IN. D., 9600 FT.) to locate a data record in a maximum average time of 60 seconds.

TAPE LOADING -- Design an automatic tape threading capability which will automatically thread the tape on the machine and bring the tape up to search speed within 20 seconds after initiating.

TAPE SWITCHING -- Design a tape switching capability which will allow at least two tape transport mechanisms to be operated from one set of electronics which can be switched between them.

DATA TRANSFER RATE -- Design an improved data transfer rate which will provide capabilities of transferring 100 MEGA-BITS/SECOND. Schemes which may be employed include; increasing the headwheel speed, increasing the number of heads/headwheel and increasing the BITS/unit transverse track length.

INTERFACE AND STAGING ELECTRONICS -- Design the necessary electronics which will provide the interface and staging capability required for: highspeed tape search, automatic tape threading, tape reel switching and highspeed data transfer rates.

A schedule for the design and feasibility demonstration of the increased capability of the transverse high density tape and the long term follow-on program for eventual system implementation is given in Figure 7-1. The initial development program is estimated to be completed in the first 12 month period.

SPECIFIC ACCOMPLISHMENTS	1Y	2Y	3Y	4Y
<u>FEASIBILITY OF HIGH RISK ITEMS</u>				
<u>DESIGN</u>				
Tape Search System	X-----X			
Automatic Tape Threading	X-----X			
Tape Reel/Electronics Switching	X-----X			
Data Transfer Rate	X-----X			
Interface & Staging Electronics	X-----X			
<u>DEMONSTRATE FEASIBILITY</u>				
Tape Search System	X-----X			
Automatic Tape Threading	X-----X			
Tape Reel/Electronics Switching	X-----X			
Data Transfer Rate	X-----X			
Interface & Staging Electronics	X-----X			
<u>DESIGN DOCUMENTATION & REPORT</u>		X-----X		
<u>PROTOTYPE BRASSBOARD OF IMPROVED CAPABILITIES</u>		X-----X		
<u>ARCHIVAL STORAGE SYSTEM IMPLEMENTATION</u>			X-----X	

7-3

ORIGINAL PAGE IS
OF POOR QUALITY

FIGURE 7-1
TRANSVERSE HDT DEVELOPMENT PROGRAM

7. 3. OPTICAL DISC DEVELOPMENT PROGRAM

Although the optical disc is inherently digital in nature, all the digital characteristics and capability of the optical disc have thus far been extrapolated from the present demonstrated analog capability. Initially, the feasibility of recording and playing back of digital data will be demonstrated. Then, the feasibility of meeting the Archival goals for storage capacity, transfer rates, transfer rate range, access time and error rate will be demonstrated for digital data. Concurrently, development of the optical disc medium will be continued so that projected life characteristics can be demonstrated as early as possible.

The following initial development program outline is proposed to increase the capabilities and demonstrate the feasibility of the optical disc to meet the requirements goal of the Archival Data Storage System to be implemented in the early 1980's.

Record and Play Back Digital Data -- Design the necessary recording and play back circuitry which can modify the present analog capability in order to demonstrate the feasibility of recording and playing back digital data.

Storage Capacity -- Design digital data storage capabilities to provide 10^9 BITS/IN² on one side of a 12 inch disc utilizing the outer 2 inch annular area of the disc. Demonstrate a storage capacity of 3×10^{10} BITS/Disc. Demonstrate capability of two sided recording, increased recording area and multiple wave length recording.

Data Transfer Rate -- Design an improved data transfer rate which will provide capabilities of transferring digital data at 100 MEGA-BITS/Second. Schemes which may be employed include; increasing the disc speed, multiple head recording/play back and multiple track recording.

Data Transfer Rate Range -- Design a variable digital data transfer rate capability. A range ratio goal is 50:1. Demonstrate a basic range ratio of 18:1.

Access Time -- Demonstrate a basic access time on the order of a few seconds from the initiation of the search to locate a data record to the initiation of the read-out of that record.

Error Rate -- Demonstrate a basic BIT error rate of 10^{-5} . Design an error detection and correction (EDAC) circuit which will provide a BIT error rate of 10^{-8} .

Optical Disc Medium -- Select feasible materials for flexible and rigid disc medium. Conduct short term environmental tests. Conduct accelerated life tests. Demonstrate recording and play back capabilities. Determine handling quality and other physical characteristics.

Disc Loading -- Design a semi-automatic system which will provide for discs loading/unloading on the optical disc recorder/player.

Interface & Staging Electronics -- Design the necessary electronics which will provide the interface and staging capability required for: high speed data search, variable transfer rates and semi-automatic disc loading/unloading.

A schedule for the design and feasibility demonstration of the basic and increased capabilities of the optical disc and the long term follow-on program for eventual system implementation is given in Figure 7-2. The initial development program is estimated to be completed in the first 18 month period.

ORIGINAL PAGE IS
OF POOR QUALITY

SPECIFIC ACCOMPLISHMENT	1Y	2Y	3Y	4Y	5Y
<u>FEASIBILITY OF HIGH RISK ITEMS</u>					
<u>DIGITAL CAPABILITY DEMONSTRATION</u>	*-----*				
<u>DESIGN</u>					
Storage Capacity	*-----*				
Data Transfer Rate	*-----*				
Data Transfer Rate Range	*-----*				
Access Time	*-----*				
Error Rate	*-----*				
Disc Loading	*-----*				
Interface & Staging Electronics	*-----*				
<u>DISC MATERIALS TEST & EVALUATION</u>	*-----*				
<u>DEMONSTRATE FEASIBILITY</u>					
Storage Capacity	*-----*				
Data Transfer Rate	*-----*				
Data Transfer Rate Range	*-----*				
Access Time	*-----*				
Error Rate	*-----*				
Disc Loading	*-----*				
Interface & Staging Electronics	*-----*				
<u>DEMONSTRATE DISC MATL. CHARACTERISTICS</u>	*-----*				
<u>DESIGN DOCUMENTATION & REPORT</u>	*-----*				
<u>PROTOTYPE BRASS BOARD OF IMPROVED CAPABILITIES</u>					
<u>MEDIUM CHARACTERISTICS DEFINITION & REFINEMENT</u>	*-----*				
<u>ARCHIVAL STORAGE SYSTEM IMPLEMENTATION</u>					
<u>MEDIUM LIFE CHARACTERISTICS & TESTS</u>	*-----*				

FIGURE 7-2
OPTICAL DISC DEVELOPMENT PROGRAM

APPENDIX A

ANALYSIS OF VARIABLE SPEED RECORDING AND PLAYBACK WITH A TILTED-HEADWHEEL

1.0 INTRODUCTION

Consider the tape/tape-head geometry situation shown in Figure 1. The tape passes over the head assembly at a longitudinal velocity V_L and this head rotates such that the tangential linear velocity at the edge is V_T . So long as V_L and V_T are fixed, the transverse video tracks assume a fixed tilted aspect on the tape in the manner shown in Figure 2. The angle of tilt for a particular recording situation is given by:

$$\theta = \tan^{-1} \left(\frac{V_T}{V_L} \right) \quad (1)$$

If playback (in a normal transverse readout mode) under different conditions from recording occurs, the route of the playback head over the tape will differ from that which occurred during recording and the stored information will not be properly retrieved. With appropriate modification of the system geometry, in particular, by testing the headwheel relative to the tape longitudinal axis, playback at rates other than the record rate can be achieved with no degradation of the recorded information. Figure 3 illustrates how this can be accomplished.

- a. Shows the normal record mode. The headwheel axis of rotation is parallel to V_L . As a result of this process, the recorded tracks on the flattened tape are straight lines. On the tape as it passes over the headwheel, the tracks are apparently curved when viewed head-on in the manner shown.
- b. Shows what happens when the tape recorded at linear velocity V_L and played back at V_P . In this case the playback process, when $V_P < V_L$, attempts to read tracks which differ from those recorded at the higher speed, and readout of data is unacceptable.
- c. Shows that the situation in b. can be rectified to yield an acceptable readout if the tape head wheel is tilted. Tilting has the effect of running the tape through at an apparently higher longitudinal velocity.

It is the purpose of the discussion below to quantify the extent to which tapes can be recorded and played back at different speeds.

The statements in b. and c. also apply if a speedup rather than a slowdown occurs. In this case $V_P > V_L$. The tilt, of course, must occur in the opposite direction.

ORIGINAL PAGE IS
OF POOR QUALITY

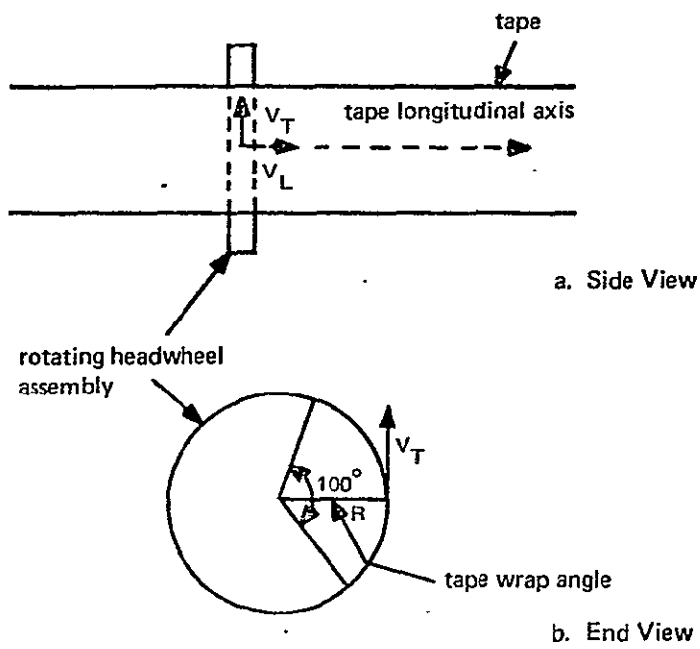

Fig. 1. Tape/Tapehead Geometry.

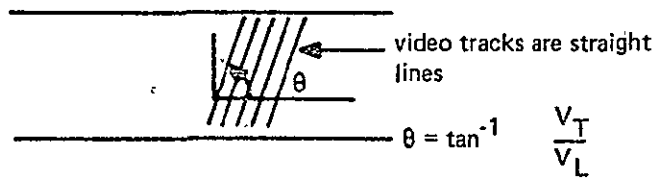

Fig. 2. Format of Recording on Tape.

ORIGINAL PAGE IS
OF POOR QUALITY A-3

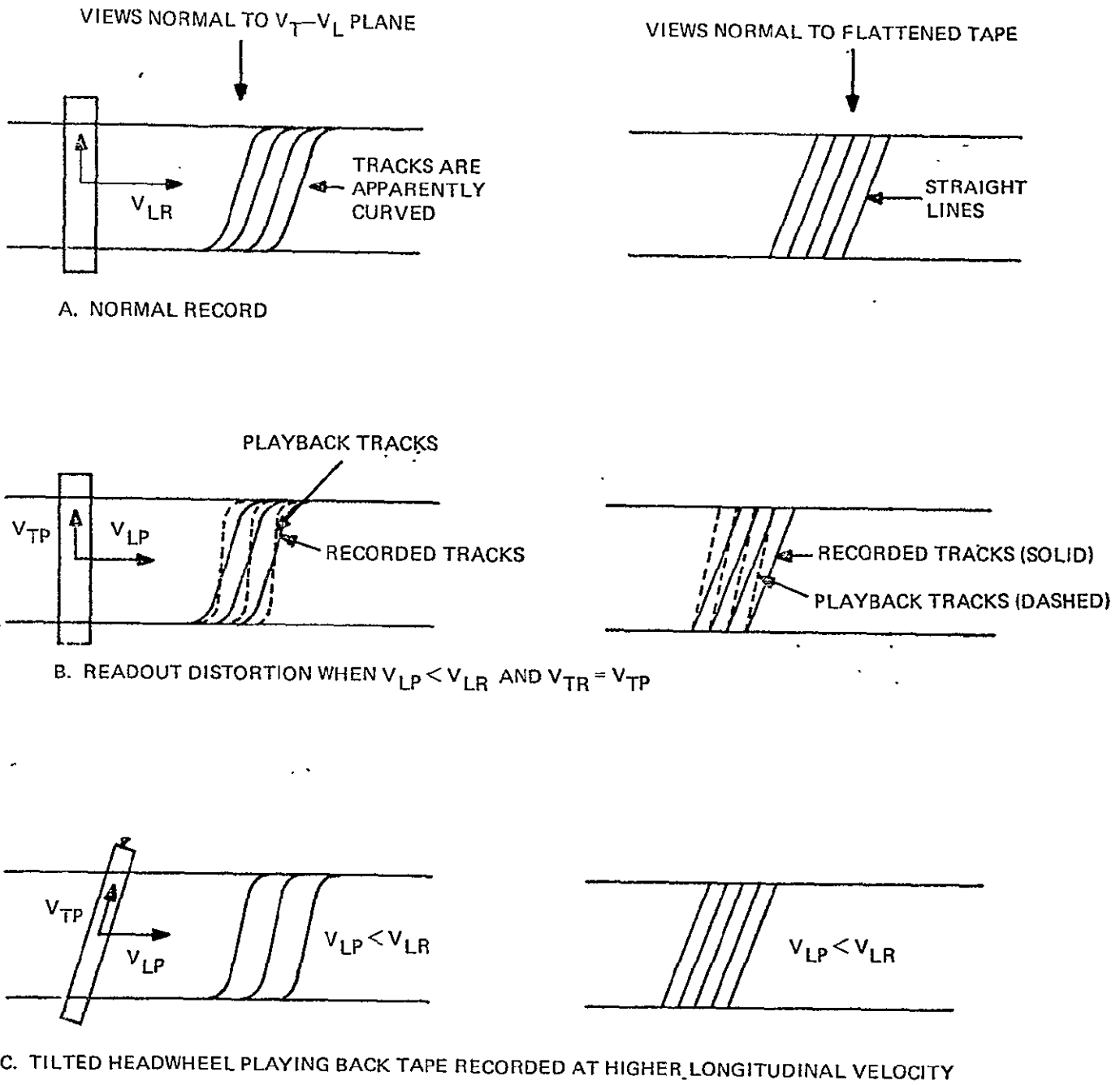

Fig. 3. Tilted Headwheel Reproduction.

2.0 TILTED HEADWHEEL PLAYBACK

Consider the diagram of Figure 4 which illustrates tape moving in the direction V_{LR} past a tilted headwheel positioned as shown.

Coordinate X and Y, originating at the tape center longitudinal axis, describe positions of a point on the headwheel projected into a plane P which is tangent to the tape surface at its center. V_{LR} , the longitudinal recording velocity, is in this plane. In terms of the parameters shown,

$$X_p(Y_p, t) = V_{LR} t + d \cos \theta \quad (2)$$

$$Y_p(t) = d \sin \theta$$

where: X_p, Y_p are coordinates in the plane defined above

θ = tilt angle referred to V_{LR}

d = position of recording head on headwheel

t = time

The parameter d is time dependent according to the rule:

$$d = R \sin(W_R t) \quad (3)$$

where R is the headwheel radius, and W_R is the angular velocity of the headwheel during recording. Using (3), (2) can be rewritten as:

$$X_p = V_{LR} t + R \sin W_R t \cos \theta \quad (4)$$

$$Y_p = R \sin W_R t \sin \theta$$

Determination of t from the second of this pair of equations as

$$t = \frac{1}{W_R} \sin^{-1} \left(\frac{Y_p}{R \sin \theta} \right) \quad (5)$$

ORIGINAL PAGE IS
OF POOR QUALITY

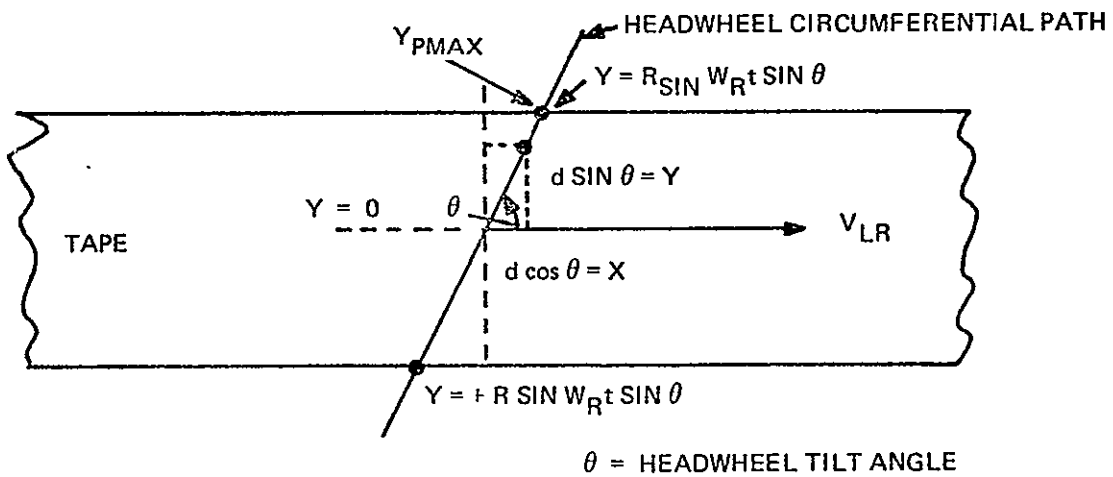

Fig. 4. Tilted Headwheel Playback.

allows writing X_p as a function of Y_p as:

$$X_p = \frac{V_{LR}}{W_R} \sin^{-1} \left(\frac{Y_p}{R \sin \theta} \right) + Y_p \operatorname{ctn} \theta \quad (6)$$

This equation is useful in expression of tracking users.

Consider now how a tracking error can be evaluated. In the case where $\theta = 90^\circ$ which corresponds to a "vertical" headwheel, eq 6 assumed the form

$$X_p = \frac{V_{LR}}{W_R} \sin^{-1} \left(\frac{Y_p}{R} \right) \quad (7)$$

The $\theta = 90^\circ$ case is always assumed to occur during recording. It is known that this type of recording generates a straight line on the tape during the record process. When the headwheel is tilted, equation 6 states that a constant proportional to $\operatorname{ctn} \theta$ is added to the X_p coordinate and that the slope of the line on the tape is modified by a constant amount. The line still remains a straight line.

The tracking error as measured on the tape in the X direction (along the direction of the tape) can be expressed as the difference between the $\theta = 90^\circ$ version of equation (6) and the more generalized version of the same equation although these are defined in the plane tangent to the tape at its center. This arises because of the equality of the X coordinate value on both the curved tape and the straight flat tape. Thus

$$X_p = X_T \quad (8)$$

where $X_p = X$ value in plane tangent to tape center

$X_T = X$ value on flat tape.

The X tracking error will be defined as δX_p , where:

$$\delta X_p = \delta X_T$$

δX_p is written:

$$\delta X_p = \frac{V_{LR}}{W_R} \sin^{-1} \left(\frac{Y_p}{R} \right) - \frac{V_{LP}}{W_{LP}} \sin^{-1} \left(\frac{Y_p}{R} \right) - Y_p \operatorname{ctn} \theta \quad (9)$$

where: V_{LP} = longitudinal playback velocity

W_P = tapehead angular velocity during playback

When $\theta \approx 90^\circ$, a useful inversion of (9) is

$$\text{ctn } \theta \approx \frac{1}{Y_P} \left(\frac{V_{LR}}{W_R} - \frac{V_{LP}}{W_P} \right) \sin^{-1} \left(\frac{Y_P}{R} \right) - \frac{\delta X_P}{Y_P} \quad (10)$$

If a value of Y_P is selected and other parameters are known, a value for θ is defined for a given acceptable tracking error δX_P . In particular, if $Y_P = Y_{P \text{ max}}$ is selected, the preferred value of θ can be chosen from equation (10) since δX_P is a monotonic function of Y_P over the range of interest. (Typically $Y_{P \text{ max}}$ is on the order of 0.7 inch and $R \approx 1$ inch).

An example will now illustrate how a tracking error is calculated using equation (9).

$$\text{Let: } W_R = W_P = (2\pi) 305 \text{ s}^{-1}$$

$$R = 1 \text{ inch}$$

$$V_{LR} = 10 \text{ inches} \cdot \text{s}^{-1}$$

$$Y_{P \text{ max}} = 0.766 \text{ inches (assumes } 100^\circ \text{ tape wrap)}$$

As recorded, the straight line tracks on the tape slope at an angle α given by

$$\alpha = \tan^{-1} \frac{V_T}{V_L}$$

$$\text{Now } V_T = W_R R = (1 \text{ in}) (305 \text{ s}^{-1}) (2\pi)$$

$$\text{Thus } \alpha = \tan^{-1} \frac{(2\pi) (305) \text{ in} \cdot \text{s}^{-1}}{10 \text{ in} \cdot \text{s}^{-1}} \text{ and the tape tracks slope at an angle of } 89.70^\circ.$$

For illustrative purposes, assume that playback at one-half the record speed requires the value of the playback tilt angle to be selected as $1/2 (90^\circ - 89.70^\circ) = 0.015^\circ$.

The playback tilt angle is thus

$$\theta = 89.70^\circ + 0.015^\circ = 89.85^\circ$$

The headwheel is tilted in the direction of the slope of the lines. Now, $\delta X_P = \delta X_T$ can be computed from equation 9.

$$\delta X_T = \frac{V_{LR}}{W_R} \sin^{-1} \left(\frac{Y_P}{R} \right) - \frac{V_{LP}}{W_P} \sin^{-1} \left(\frac{Y_P}{R} \right) - Y_P \operatorname{ctn} \theta$$

$$\delta X_T = \frac{10 \text{ in. s}^{-1}}{2\pi(305) \text{ s}^{-1}} \sin^{-1} \left(\frac{Y_P}{1 \text{ in}} \right) - \frac{5 \text{ in. s}^{-1}}{2\pi(305) \text{ s}^{-1}} \left(\frac{Y_P}{1 \text{ in}} \right) - Y_P (0.002618)$$

At $Y_{\max} = 0.766 \text{ in.}$,

$$\sin^{-1} (0.766) \approx 50^\circ = 0.8726 \text{ radians.}$$

Thus

$$\begin{aligned} \delta X_T &= 0.00522 && (0.8726) \\ &- 0.00261 && (0.8726) \\ &- (0.766) && (0.002618) \\ \delta X_T &= 0.00028 \text{ inches} \end{aligned}$$

This value is used within a typical allowable tracking error by a factor of 4. It still, however is a non-zero error, indicating that a preliminary choice of tilting by an angle proportional to the record to playback speed ratios is not optimum.

Consider now optimization of the tilt angle by using equation (10). Let the optimum tilt angle θ_0 be defined as

$$\theta_0 = \operatorname{ctn}^{-1} \left\{ \frac{1}{Y_P} \left(\frac{V_{LR}}{W_R} - \frac{V_{LP}}{W_P} \right) \sin^{-1} \left(\frac{Y_P}{R} \right) - \frac{\delta X_{P\min}}{Y_P} \right\}$$

ORIGINAL PAGE IS
OF POOR QUALITY

Let the tracking error at $Y_{\max} = \delta X_{P\min} = 0$ inch be specified

At $Y_P = Y_{P\max}$ then,

$$\begin{aligned} \theta_o &= \text{ctn}^{-1} \left\{ \frac{1}{0.766} \left(\frac{10 \text{ in. s}^{-1}}{2\pi(305)\text{s}^{-1}} - \frac{5 \text{ in. s}^{-1}}{2\pi(305)\text{s}^{-1}} \right) \sin^{-1} \frac{Y_P}{R} \right\} \\ &= \text{ctn}^{-1} \left\{ 1.3054 \left(\frac{5}{2\pi(305)} \right) \frac{50}{57.3} \right\} \\ &= \text{ctn}^{-1} 0.002972 \\ \theta &= 89.8297^\circ \end{aligned}$$

It is seen that this optimum angle θ_o is very close the tilt angle selected by the rule of tilting by an angle equal to half the angle of the recorded video tracks.

An illustration of the range of variation in tracking error with angle is shown in Figure 5. Significance of the + and - signs are lead and lag of the playback head position relative to the recorded tracks ($\delta x = \text{recorded line position} - \text{playback head track position}$). It is seen that a + 0.0005 inch tracking error range is achieved by allowing an angular tolerance of 0.08° .

3.0 RECORD AND PLAYBACK WITH THE VERSABIT SYSTEM

The above analysis will now be applied to the Versabit system operating in the various modes of playback and record in order to establish the requirements for headwheel tilting.

First, consider the basis for requiring the headwheel to tilt. The need arises because the recording and playback processes utilize continuously variable linear tape speeds (V_{LR} and V_{LP}) and headwheel rotation rates $\frac{W_R}{2\pi}$ and $\frac{W_P}{2\pi}$.

Without the compensation offered by tilted headwheel reproduction, the recorded data could not be reproduced properly.

Details of record characteristics are shown in Figure 6. There are six regions defined by binary decrements of the maximum record data rate of 20 Mb. s^{-1} . Corresponding to each of these regions, there is a continuous range of headwheel rotation speeds from 152.5 r. s^{-1} to 305 r. s^{-1} . The longitudinal tape speed V_{LR} also varies continuously with frequency in the manner shown.

ORIGINAL PAGE IS
OF POOR QUALITY

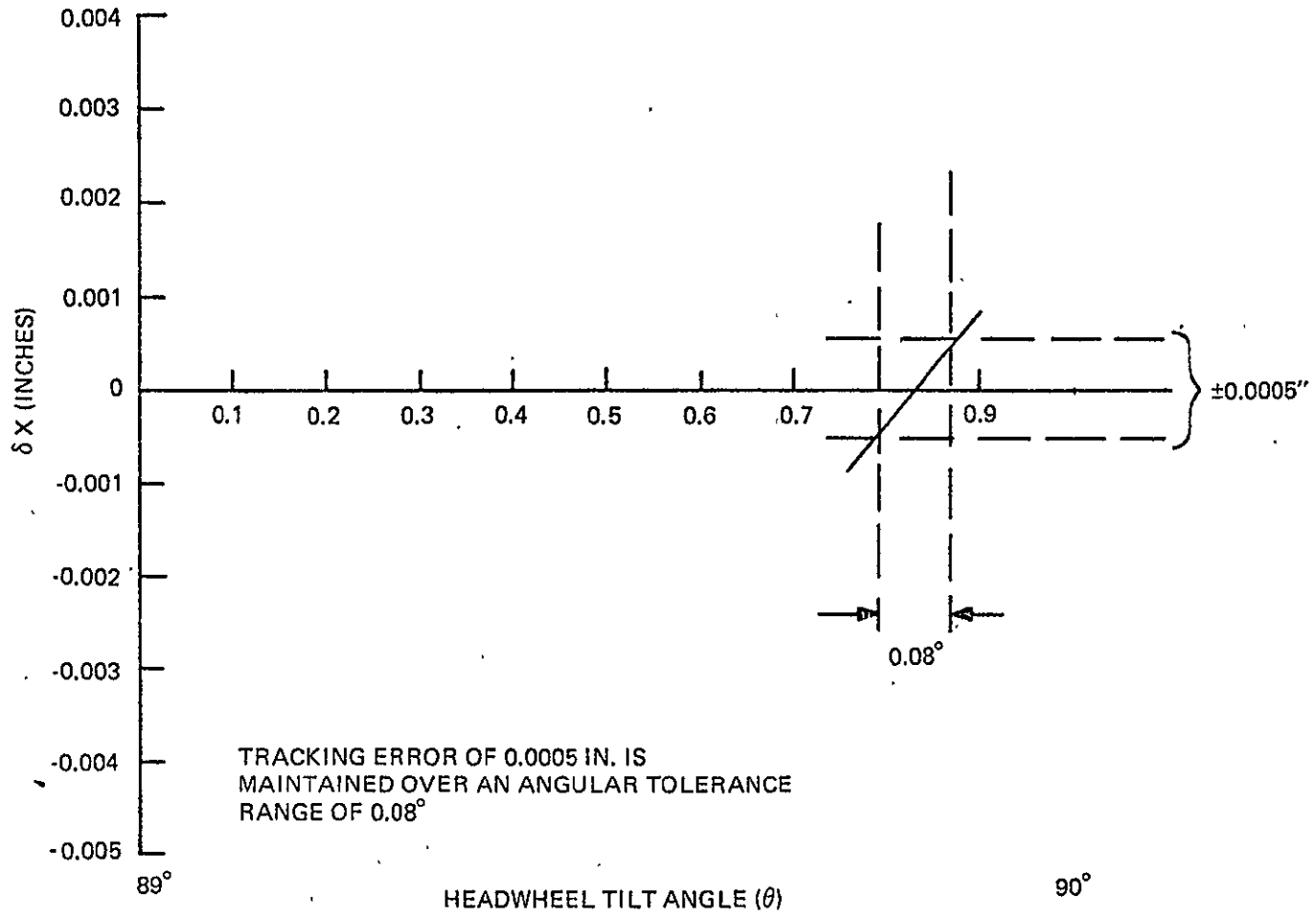

Fig. 5. Tracking Error vs. Tilt Angle.

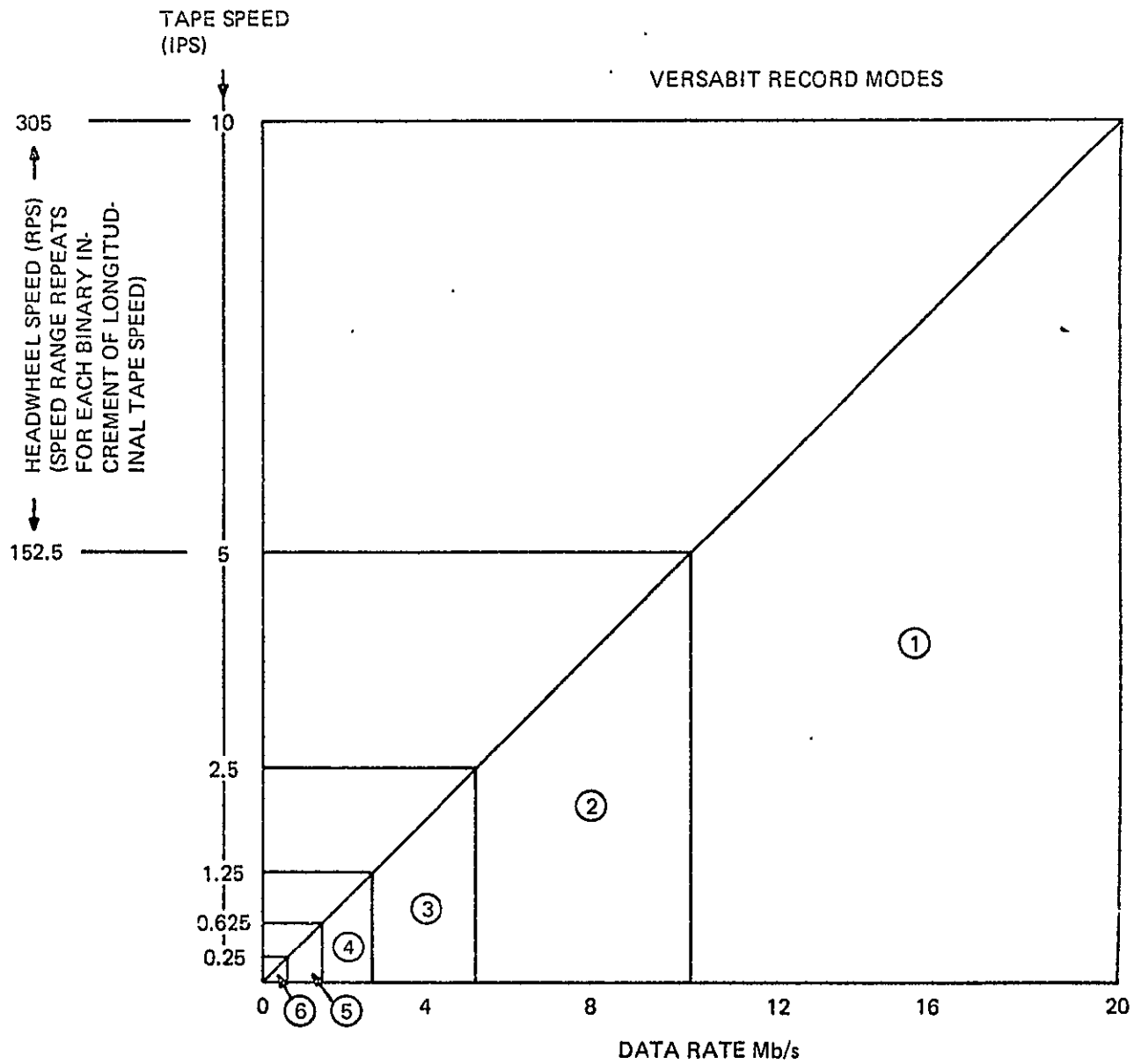

Fig. 6. Recording parameters V_{LR} and $W_R/2\pi$ as functions of data rate.

Playback characteristics are shown in Figure 7. Similar variability of linear speed V_{LP} is shown as is a 2 to 1 variation of W_P over a binary decrement of the data rate. The A, B and C regions are those covered in the actual machine by three different plug-in modules.

An investigation of headwheel tilting must consider two aspects of the problem; first, the extent to which the headwheel must tilt under any set of operating conditions, and second, the allowable granularity of the tilt adjustment. Both can be considered by using equation 10 derived above in two different ways. Equation 10 will be reproduced here for reference.

$$\text{ctn } \theta = \frac{1}{Y_P} \left(\frac{V_{LR}}{W_R} - \frac{V_{LP}}{W_P} \right) \sin^{-1} \left(\frac{Y_P}{R} \right) - \frac{\delta X_P}{Y_P} \quad (10)$$

If $\delta X_P = 0$ for a given set of conditions, an optimized value for θ can be obtained. If $\delta X_P = \pm$ (allowable tracking error), a range for θ over which acceptable tracking occurs can be determined.

Before proceeding, consider how the headwheel panel must be adjusted to achieve a given tilt angle. See Figure 8. The panel is adjusted by raising one end of the panel a height h above a reference portion where the tape head is exactly perpendicular to the tape longitudinal direction. Examination of Figure 8 shows that:

$$h = l \sin B \quad (11)$$

where h = elevation height

l = distance between pivot point and point of elevation measurement

B = tilt angle (horizontally referred)

In terms of vertically referred angle θ used in equation 10,

$$h = l \cos \theta \quad (12)$$

Equivalently

$$h = l \sin \theta \text{ ctn } \theta \quad (13)$$

and, as long as $\theta \approx 90^\circ$, a condition which occurs for all cases of interest,

$$h \approx l \text{ ctn } \theta \quad (14)$$

Using equations 14 and 10, the angle of tilt, and the height of the headwheel panel adjustment can be determined.

ORIGINAL PAGE IS
OF POOR QUALITY

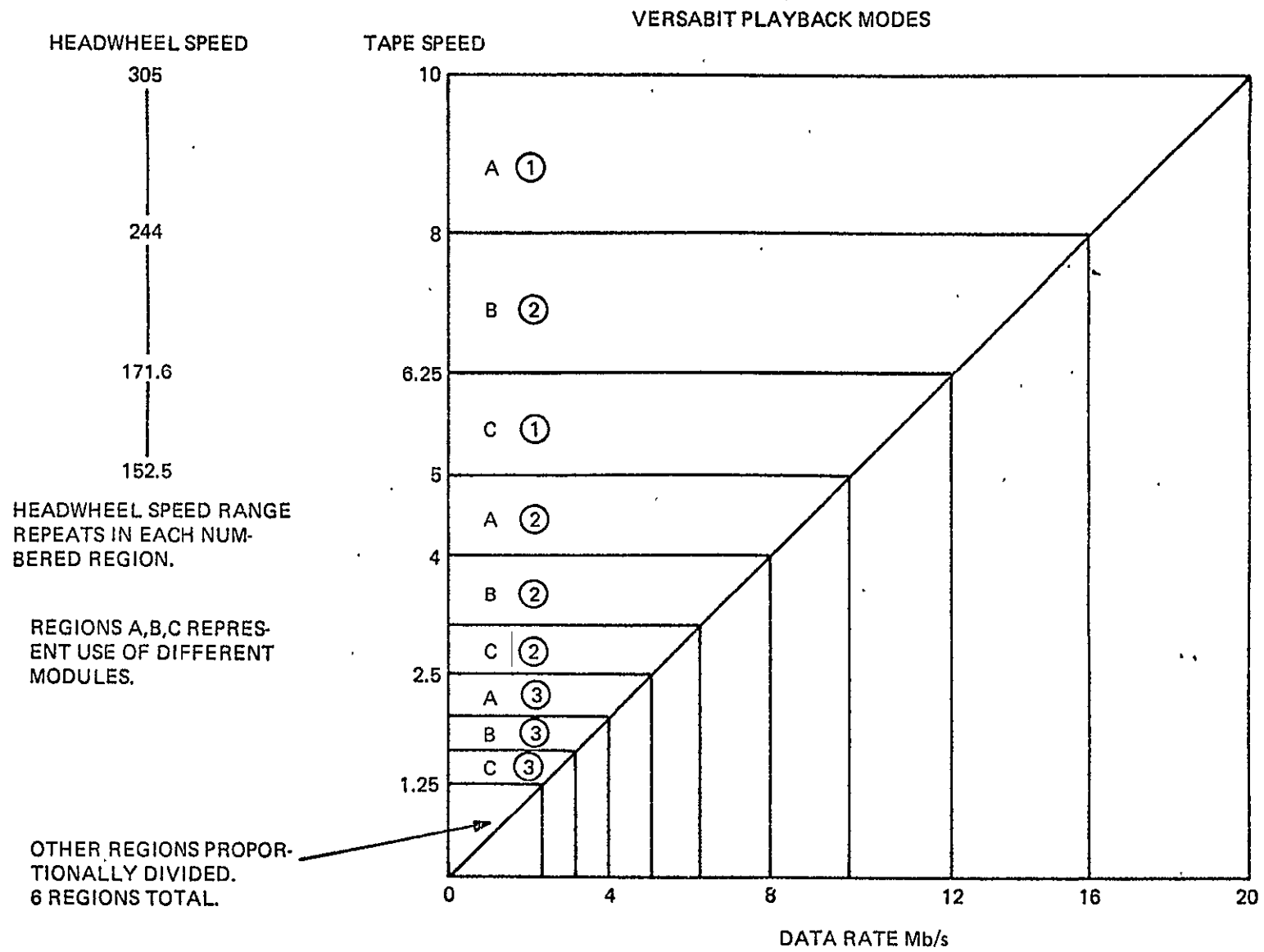
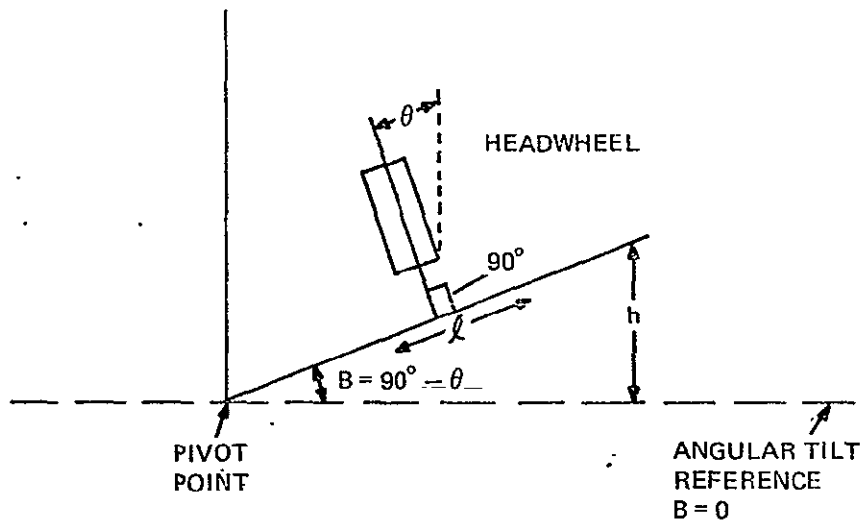

Fig. 7. Playback Parameters V_{LP} and W_P as functions of data rate.



ORIGINAL PAGE IS
OF POOR QUALITY

Fig. 8. Tilted headwheel panel geometry.

Consider now analysis of the Versabit system in its various modes. Figure 9 shows a particularly useful combined representation of the recording and playback parameters. An important feature of this representation is the illustration that for each of the regions of interest:

$$\frac{V_{LR}}{W_R} = \text{constant} \tag{15}$$

$$\frac{V_{LP}}{W_P} = \text{constant}$$

Examination of equation 10 shows that when these ratios are constant over specified regions, only one value of headwheel angle tilt will suffice to properly reproduce data recorded anywhere within one region by playing back with V_{LP} and W_P properties particular to any selected playback region.

Constancy of the V_L parameters in the various regions thus makes it possible to completely specify tilt angle requirements as a function of data rate by analyzing the tilt requirements necessary to reproduce data recorded in the region 10 to 20 Mb/s in any other region of interest.

Specifically, consider a recording made such that $W_R = 2\pi(305)s^{-1}$ and $V_{LR} = 10 \text{ in. s}^{-1}$. Using these values and the parameters:

$$Y_{Pmax} = 0.766 \text{ inch for } 100^\circ \text{ tape wrap}$$

$$R = 1 \text{ inch}$$

It is possible to write the tilt angle (or equivalently, its cotangent) for any playback region as:

$$\text{ctn } \theta = \frac{1}{Y_P} \left(\frac{V_{LR}}{W_R} - \frac{V_{LP}}{W_P} \right) \sin^{-1} \left(\frac{Y_P}{R} \right)$$

$$\text{ctn } \theta = \frac{1}{0.766} \left(\frac{10 \text{ in. s}^{-1}}{2 (305)s^{-1}} - \frac{V_{LP}}{W_P} \right) (0.8725) \tag{16}$$

$$\text{ctn } \theta = 1.139 \left(0.00522 - \frac{V_{LP}}{W_P} \right)$$

$$\text{ctn } \theta = 0.00594 - 1.139 \frac{V_{LP}}{W_P}$$

ORIGINAL PAGE IS
OF POOR QUALITY

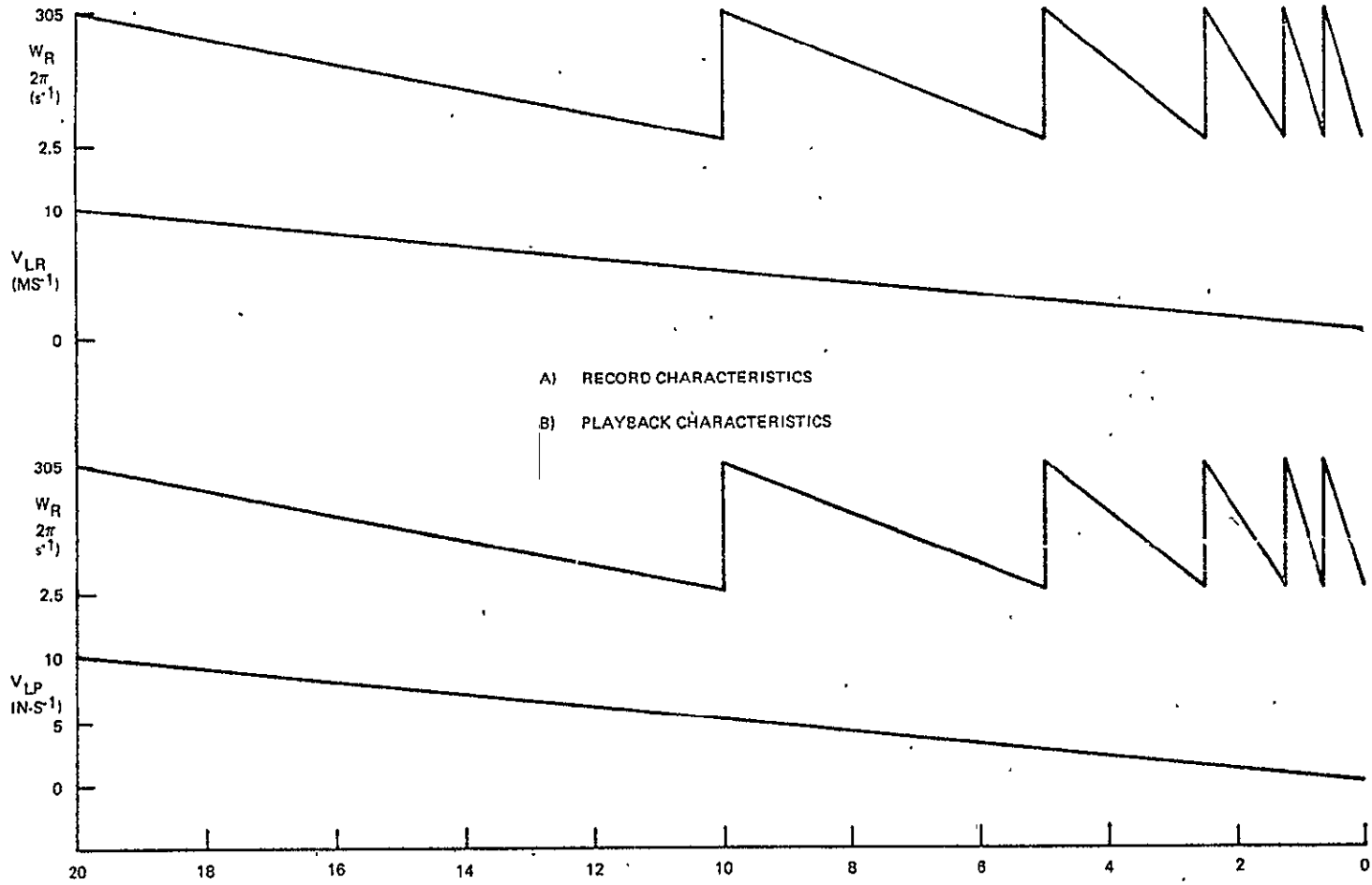

Fig. 9. Velocity Modes During Record And Playback.

when appropriate values are specified for V_{LP} and W_P . Examination of Figure 9 shows that a particularly useful set of pairs of these values are those shown in Table I. These values occur at each of the "step" transitions between the various regions. Table II summarizes the calculations for the appropriate tilt angle between the regions. Shown with the actual angle is a tolerance which allows for a total (record and playback) maximum tracking error of ± 0.001 inch. These tilt angle tolerances are calculated by using equation 16 in the full form

$$\text{ctn } \theta = 0.00594 - 1.139 \frac{(V_{LP})}{(W_P)} - \frac{\delta X}{Y_P}$$

where δX , the allowable error assumes the values ± 0.0005 . 1/2 mil is allowed for recording error and 1/2 mil is allowed for a playback error.

The last column also shows the required elevation per unit length of the headwheel panel to achieve the required headwheel angle tilt.

Figure 10 is a graphical presentation of Table II data. The headwheel tilt angle and the panel tilt per unit length are specified as functions of the data rate. It is readily seen that:

- the nominal excursion of tilt angle for 0 to 20 Mb.s⁻¹ data rate is 0.35°.
- discrete steps in θ are required when there is a large disparity in record and playback data rates.
- in regions 4, 5, and 6 (corresponds to $0 < \text{data-rate} < 2.5 \text{ Mb.s}^{-1}$) tolerances greatly relieve the angle shift requirement. If tracking is very good, no angle tilt adjustment will be needed.

TABLE I. REPRESENTATIVE PLAYBACK PARAMETERS

Region	$V_{LP}(\text{in. s}^{-1})$	$\left(\frac{W_P}{2\pi}\right)\text{s}^{-1}$
1	10	305
2	5	305
3	2.5	305
4	1.25	305
5	0.625	305
6	0.25	305

TABLE II. ANGULAR TILT REQUIREMENTS

Data Recorded in Region 1,
Playback in

Region	Calculated Value $\text{ctn } \theta$	Headwheel Tilt Angle θ	Upper and Lower Limits on θ	Headwheel Panel Elevation Present Length h/l
1	0	90°	$\theta_{\min} = 89.9626^\circ$	0
2	0.00297	89.8298°	$\theta_{\max} = 89.8672^\circ$ $\theta_{\min} = 89.7924^\circ$	0.00297
3	0.00445	89.7447°	$\theta_{\max} = 89.7821^\circ$ $\theta_{\min} = 89.707^\circ$	0.004455
4	0.00519	89.7022°	$\theta_{\max} = 89.7399^\circ$ $\theta_{\min} = 89.6653^\circ$	0.0051
5	0.00556	89.6809°	$\theta_{\max} = 89.7186^\circ$ $\theta_{\min} = 89.6441^\circ$	0.00556
6	0.00579	89.6683°	$\theta_{\max} = 89.7056^\circ$ $\theta_{\min} = 89.6309^\circ$	0.00579

ORIGINAL PAGE IS
OF POOR QUALITY

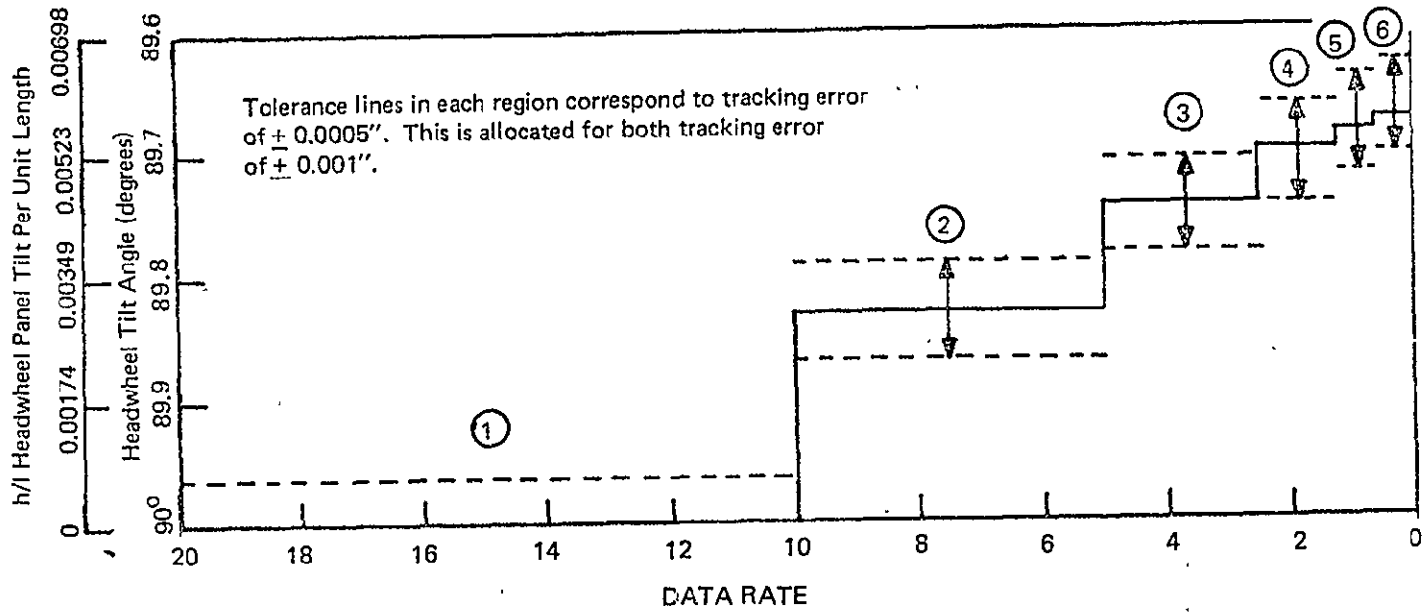

Fig. 10. Headwheel Angle Tilt Requirements As Function of Data Rate.

RECENT ADVANCES IN MAGNETIC RECORDING OF DIGITAL DATA

By O.E. Bessette

High Density digital recording on magnetic tape is discussed in terms of bit area density, bit linear density and track density. It can be shown that the present linear bit packing density capability is within 2:1 of the technology limit whereas the present track packing density capability is less than 1/10 of the present technology limit.

Two approaches to increase track density are cited; fixed head recording for data rates up to 1 Gigabit/second and rotary head recording for rates up to 40 Megabits/second. Rotary head hardware is described which presently yields over one million bits per square inch (MBPI²) and has been verified to over 5 MBPI²[1], with a projected yield of over 2 Terabits on a 10-1/2-inch reel of tape.

This paper primarily describes recent advances in rotary head techniques. The fixed head developments (RCA HDMR) are described more fully in references [2] [3].

Recording Systems
Government Communications Systems
Camden, New Jersey

Presented at:

International Telemetry Conference (ITC)
Sept. 28-30, 1976. Los Angeles, California



Oliver E. Bessette, Leader, Recording Systems, Government Communications Systems RCA, Camden, N.J., received the BSEE in 1958 from the Worcester Polytechnic Institute. He has 12 years of hardware and system engineering experience in design and development of 6 MHz wideband elint/commint recording systems for spacecraft, portable and fixed site applications—specializing in head-tape interface and signal processing.

Since 1970, Mr. Bessette has been the principal investigator and design group leader in development of two high rate digital recording technologies, 80 tracks/inch fixed head and 200 tracks/inch rotary head systems. He has published several papers, has a patent on a magnetic head, and is a member of the IEEE group on magnetics.

INTRODUCTION

Applications for large digital memories (typically image data bases) operating at variable transfer rates from 1 megabit/second to 1 gigabit/second have spurred the development of higher density magnetic tape systems. Typical storage requirements of 10^{11} to 10^{13} bits or record times of several minutes at over 240 megabits/second require area and volume packing densities far beyond that available with standard instrumentation recorders or solid state devices. Fast access and reusable medium make magnetic tape more operational and less expensive than optical film.

Magnetic Head technology is approaching the bits/inch (BPI) limit of available magnetic tape, but is far from the tracks/inch (TPI) limit. As a trade-off, TPI vs BPI shows a distinct advantage to increasing TPI. Present systems operate at head-tape separation and particle sizes which are near limiting, and at wave lengths where tape self demagnetization and write field gradients limit the magnetic moment of each bit on tape.

HIGH DENSITY DATA RECORDING

High Density Digital Recording on Magnetic Tape is NOT just high bits/inch. It is high bits/square inch (BPI^2) and high bits/cubic inch (BPI^3).

The literature and most studies on high bit packing density have been heavily weighted to increase Linear Bit Density. But, Area and Volume Packing Densities are extremely important in High Data Rate Systems and in Long Record Time or Data Archival Systems.

HIGH RATE RECORDING

To achieve high data rates, high density recording and high head-tape speed is needed. Figure 1 shows that High Rate recording needs high bits/inch (BPI) and high tracks/inch (TPI). The status and limit of BPI and TPI are indicated.

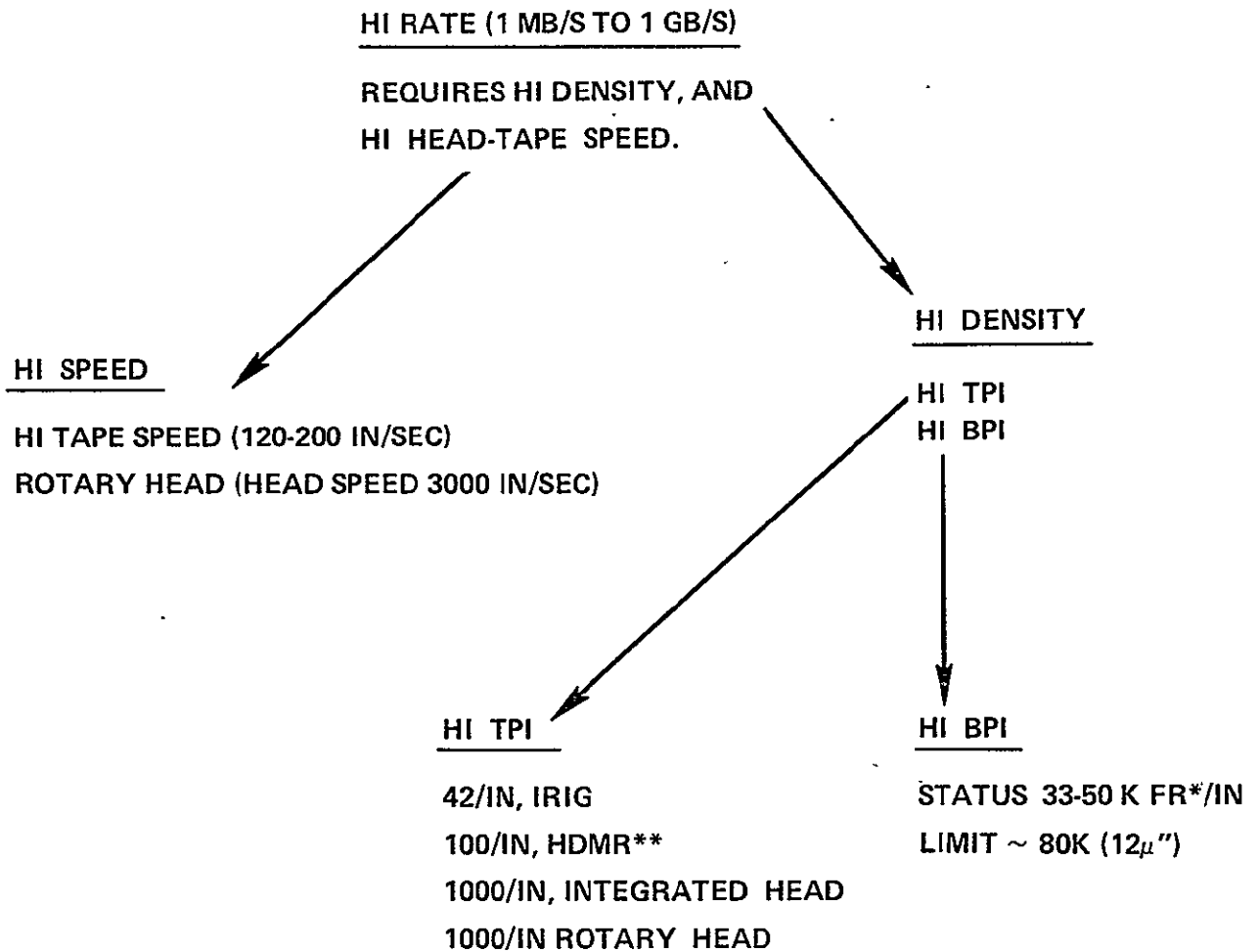

ORIGINAL PAGE IS
OF POOR QUALITY

*FR, FLUX REVERSAL
**HDMR, RCA DEVELOPED HIGH DENSITY MULTITRACK RECORDING

Figure 1. High Rate Recording

PACKING DENSITY LIMITS

Figure 2 shows the packing density limits of fixed head systems in terms of BPI, TPI and BPI^2 ($BPI^2 = TPI \times BPI$). Present recording systems have achieved a status of 50 per cent of the potential BPI but only 10 per cent of the potential TPI and 5 per cent of the potential BPI^2 . At 50K BPI and 120 inches/second the channel rate is 6 megabits/second. This channel rate times the TPI limit is 12 gigabits/second, as an outside limit for 2-inch tape.

Figure 3 shows the packing density limits for Rotary Head systems, specifically the quadruplex transverse scanning technique. Present rotary head systems have achieved a status of 50 per cent of the potential BPI but only 5 per cent of the potential TPI and 1 per cent of the potential BPI^2 . The channel rate limit is not a function of BPI or head-tape speed. It is limited by the frequencies and timing tolerances in the read/write process to about 50 megabits/second. This rate can be achieved at 1000 inches/second and 50K BPI, at 3000 inches/second and 17K BPI or any inbetween combination. A 2-channel recorder would yield a 100 megabit/second system.

SYSTEM LOSSES AT HIGHER BPI

A severe loss of performance is observed at higher BPI which stems partly from the fact that the data must be transferred to/from the tape via magnetic transducers across an "air gap". This air gap is the effective separation of head and tape and is never zero because it is limited by the surface roughness of both the head and tape; debris on the head or tape surfaces; holes, scratches or other damage to the head or tape surface; tape tension losses or serious perturbations; and aerodynamic "floating" incurred at high tape speeds. This performance loss is due to the spatial field reduction caused by the physical separation of the transducer and storage medium. This loss is the well known 54 dB/wavelength. Since BPI is inversely proportional to wavelength, the signal loss involved is very large at high BPI for even small separations. The surface roughness of the tape alone is in the order of 6×10^{-6} inches (for quality tape) not including oxide protuberances caused by clumping of the mix during coating. For example, at 33 KBPI, NRZ DATA is 16,500 cycles/inch or 66×10^{-6} inch/cycle.

<u>BPI*</u>	<u>TPI</u>	<u>BPI²</u>
LIMITED BY TAPE	LIMITED BY HEAD TECHNOLOGY	(@ 50 KBPI)
PARTICLE SIZE AND DISTRIBUTION	42/IN IRIG	2 x 10 ⁶
RECORD DEMAGNETIZATION	100/IN HDMR	5 x 10 ⁶
SURFACE IRREGULARITIES	1000/IN INTEGRATED HEADS	50 x 10 ⁶
50K IS > 50% OF 80K	10% OF POTENTIAL	5% OF POTENTIAL

CHANNEL RATE LIMIT: 50 KBPI x 120 IN/S = 6 MB/S

*FLUX REVERSAL'S (FR) PER INCH IS USED AS A BASE FOR COMPARISON

Figure 2: Packing Density Limits — FIXED HEADS

ORIGINAL PAGE IS
OF POOR QUALITY

	<u>BPI (FR/IN)</u>	<u>TPI</u>	<u>BPI²</u>
STATUS	10K TO 20K	133	1 TO 2 x 10 ⁶
LIMIT	~ 50,000	> 2000	~ 10 ⁸
	50% OF POTENTIAL	5% OF POTENTIAL	1% OF POTENTIAL

CHANNEL RATE LIMIT: 50 MB/S (1000 IN/S x 50 KBPI OR 3000 IN/S x 17 K BPI).
TWO CHANNELS ARE EASILY IMPLEMENTED YIELDING A TECHNIQUE
LIMIT OF 100 MBPS.

Figure 3. Packing Density Limits — ROTARY HEAD (Quadruplex)*

*Quadruplex, term used for transverse scan recording with four heads on headwheel.

C-2

At 54 dB/66 x 10⁻⁶ inches, the surface roughness causes a nominal signal loss of 4.9 dB. Tape imperfections of 15 x 10⁻⁶ inches are common which cause an additional 12 dB of loss. Record demagnetization effects are the second major loss area which reduces the available magnetic moment of each bit on tape as the BPI is increased. For these and other loss factors, higher BPI yields diminishing returns rather quickly. Reliability is reduced due to lower signal levels (less level margin to drop outs).

BPI VS. TPI

For any given moderately high BPI system, a 2:1 increase in packing density will cost at least 18 dB of S/N margin the BPI way and only 3 dB the TPI way. Figure 4 illustrates the relative gain/loss in system signal to noise ratio (S/N) when the track width (W) is varied or the wavelength (BPI) is varied. The conclusion one must make is that in a BPI vs TPI trade-off, the performance improvements are weighted toward TPI increase and BPI decrease. For any given system, 1/2 the BPI and 2X the TPI equals better performance.

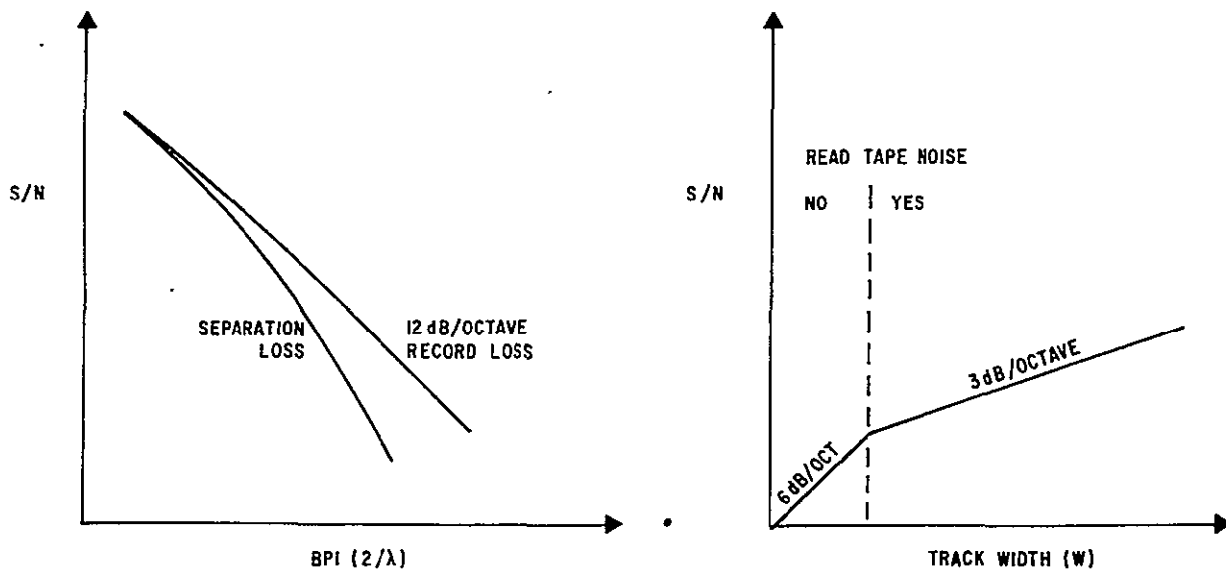

Figure 4. Relative Gain Loss Values

The scale factors of the head-tape interface limit the BPI performance (one bit per flux reversal is assumed) to about 80 KBPI. The scale factors which are limiting BPI (mostly due to the tape itself) are: head-tape separation; tape imperfections; tape magnetic particle size (typically 12 microinches), distribution and self demagnetization fields; bit width to length ratio (25×10^{-3} and 30×10^{-6} inches at 28 TPI and 33 KBPI) and; head gap length to depth ratio (smaller gaps require shallower pole-face depths which are more difficult to achieve and have a short head life).

TPI is presently limited not by the magnetic tape, but by head construction technology. Recent advances in TPI have proven the worth of this approach as opposed to the high BPI approach. IBM 3330 disc drives operate at 400 TPI and 4,000 BPI at 40 micro-inch fly height. The Winchester system is 480 TPI and CDC is testing 600 TPI. The RCA video disc is 5,555 TPI. All of these systems have excellent BER by instrumentation/telemetry standards. The success of this approach is illustrated in Table 1. High TPI requires improved tape tracking requirements, but this has yet to prove limiting in any system and several techniques are easily applied to tape.

High density (TPI) magnetic heads require new technology to replace the discrete IRIG/audio head style. The RCA HDMR^[2,3] heads are one technology that has achieved over 100 TPI using unitized metal head construction to address 200 to 2,000 Mb/s record rates. Other companies are pursuing integrated magnetic head technology for goals of 1000 TPI at disc rates (<8 Mb/s).

DIRECT SOLUTIONS TO HIGH BPI²

Our analysis thus far indicates that lower BPI (longer wavelength) and higher track densities will yield a higher BPI². Attempts to increase wavelength at high data rates fall into two categories: 1) increase the number of tracks, and 2) increase the tape speed. Both categories are briefly discussed below. However, attempts to increase tape speed quickly lead to complicated tape transport problems, inefficient tape utilization, and operational problems.

ORIGINAL PAGE IS
OF POOR QUALITY

TABLE 1. SCALE FACTOR LIMITS

	KBPI (KFR/in)	Tracks per Inch	MBPI ²	d (u'')	Separation Loss dB	BIT 1 (u'')	Size W (u'')	Square- ness Factor (W/l)	Part Count per BIT (p/l)	P/l Loss Factor
IRIG (Present)	33	28	0.9	10	9 dB	30	25x10 ³	833	2.5	2 dB
HDMR (Present)	25	80	2.0	10	7 dB	40	8x10 ³	200	3.3	1 dB
3330 Disc (Updated)	4	400	1.6	40	4 dB	250	2.5x10 ³	10	12.5	0 dB
IRIG (Development)	50	28	1.4	10	14 dB	20	25x10 ³	1,250	1.7	4 dB
Rotary Head (Present)	10	133	1.3	10	3 dB	100	5x10 ³	50	8.5	0 dB
Rotary Head (Development)	10	266	2.6	10	3 dB	100	2.5x10 ³	25	8.5	0 dB
Rotary Head (Future)	10	533	5.3	10	3 dB	100	1.25x10 ³	12	8.5	0 dB

Tape particle size (p) of 12×10^{-6} inches assumed.

1. Increase the Number of Tracks. For very high data rates (100-1000 megabits/second) a High Density Multitrack Recording (HDMR) fixed head longitudinal recording technique was developed by RCA. The HDMR head shown is Figure 5 in 164 tracks on 2-inch tape and operates at 2 megabits/second at 80 inches per second. The system performance is therefore over 300 megabits/second at 25 KBPI and 2×10^6 BPI². This system is currently being developed by NASA for Space Shuttle application. Figure 6 shows the NASA 240 megabits/second HDMR breadboard system which is scheduled for demonstration by the end of 1976. Features of this system are; only one adjustment per channel, and hybrid and LSI (future) electronics. A study contract for AN/UPD-X flight recording was recently completed for the Air Force Avionics Labs. Figure 7 shows the flight recorder and ground reproducer systems configured for 200 to 400 megabits/second application.

2. Increase the Tape Speed. Aside from partial success with the Newell Drive technique, High Density digital longitudinal recording is limited to the 120 to 180 inch/second tape speed range. Higher speeds are presently unreliable. Many years ago, a unique approach to high tape speed was developed by Ampex and RCA for TV recording. If the tape can't be moved fast enough, move the head! Rotary head recording

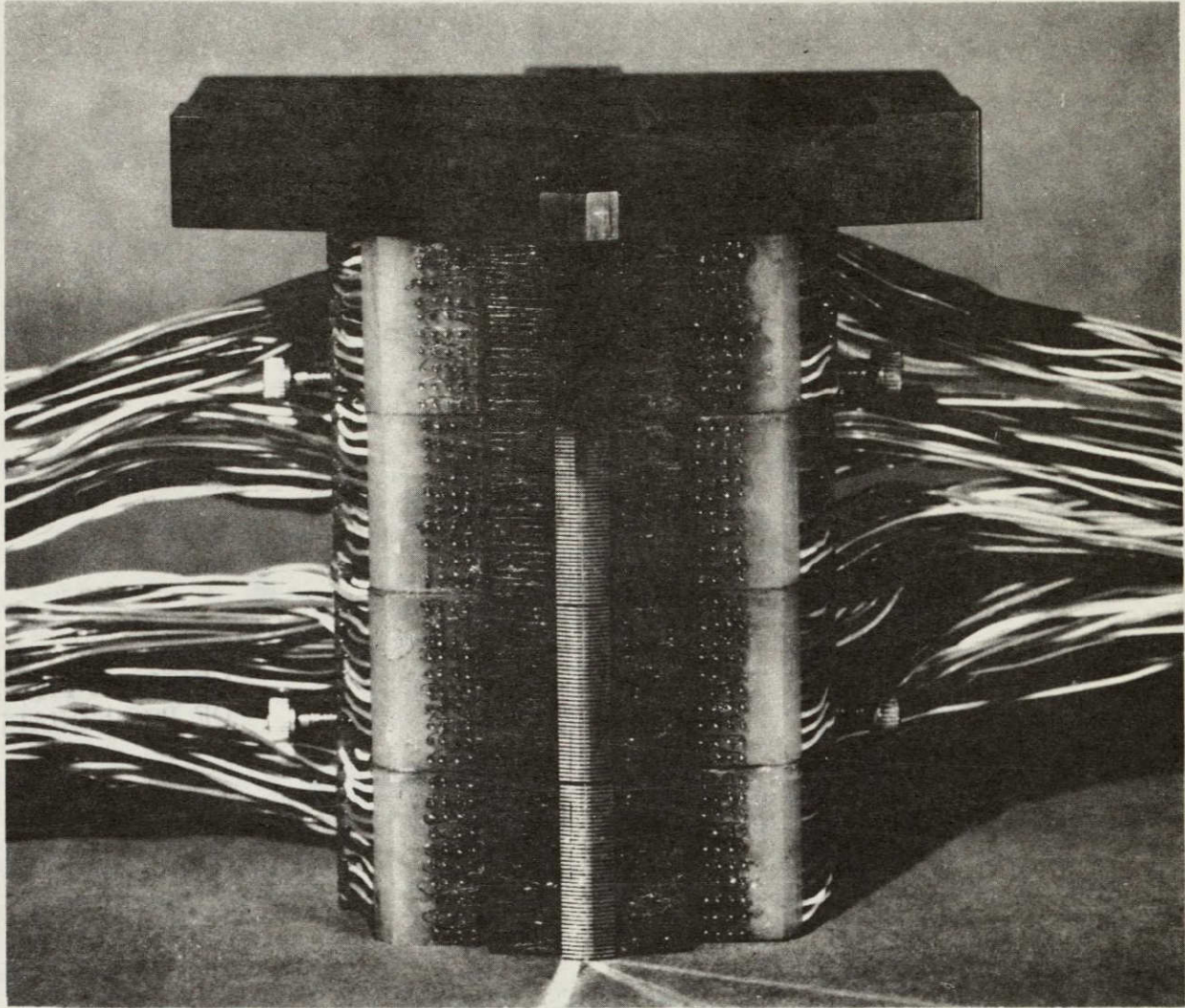
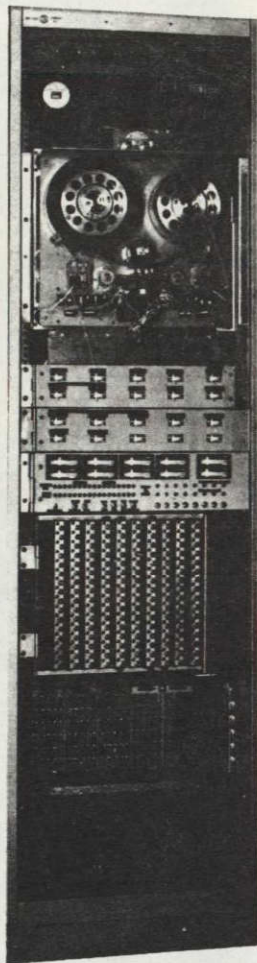

Figure 5. 164-Track High Density Multichannel Recording Head

came into being and is now available in two basic forms; transverse recording and helical recording.* Transverse recording rotates the head at 90° to the tape motion and therefore the longitudinal tape motion has nothing to do with the fundamental performance of the channel. The first practical system developed with this technique is called "quadruplex recording" because 4 heads are mounted at 90° intervals around a wheel. This minimizes the required tape wrap arc around the heads to 90° and allows a very practical mechanical configuration. A tape guide is used to hold the tape in this

*Another approach described in the literature (segmented helical scan) is partially equivalent to transverse scan but still retains most of the characteristics of helical scan.



ORIGINAL PAGE IS
OF POOR QUALITY

Figure 6. 240 Megabits/Second Breadboard System

arc configuration and provides further advantages in head-to-tape interface control uniformity and reliability. One disadvantage of quadruplex is that four heads optimally require four channels of record/play transfer electronics. Helical scan recorders were developed because they only need one or two channels of record/play transfer electronics and can use standard longitudinal tape, making them seemingly less costly units^[4]. The helical scan, however, does not decouple the data channel from the longitudinal tape motion. This results in a system which has most of the disadvantages of both rotary head systems and longitudinal systems.

A FIELD PROVEN TECHNIQUE AT 133 TRACKS/INCH

Transferring TV data at 1560 inch/second on 0.010 and 0.005 inch tape tracks was standardized over 15 years ago. The standard ASA C98.6 tape format was developed

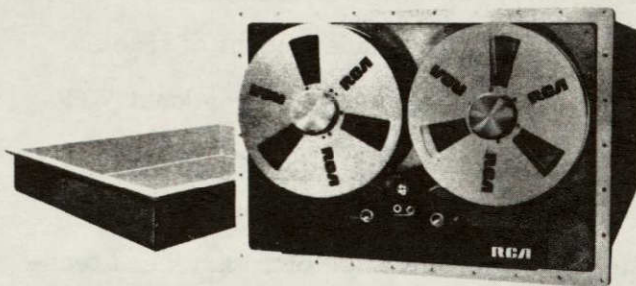

FLIGHT UNIT

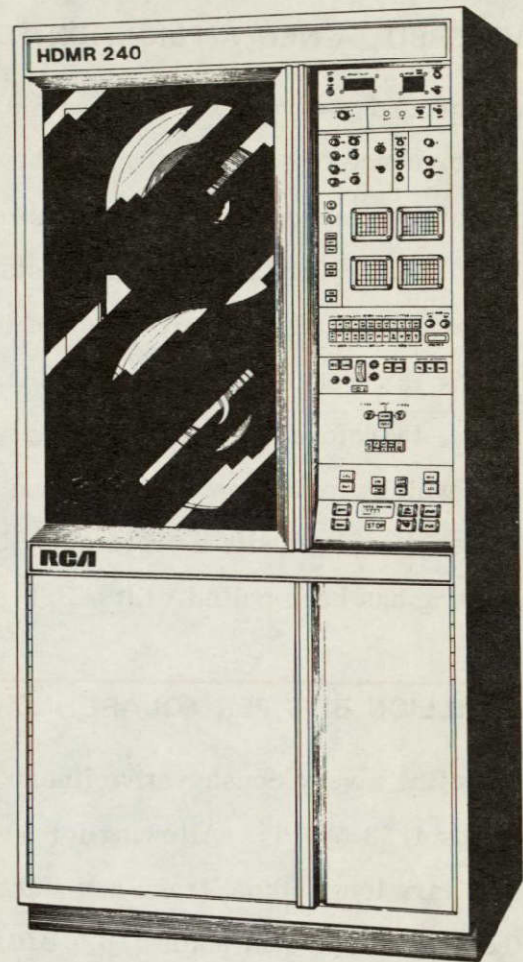

GROUND UNIT

ORIGINAL PAGE IS
OF POOR QUALITY

Figure 7. HDMR System Configurations

and field proven by thousands of recorders and millions of heads. Many equipment types are presently available. The present VTR equipment transfers signals on/off tape over an FM bandwidth from 500 kHz to 16 MHz frequency spectrum. Government applications of this device have extended this range up to 40 MHz and down to 50 kHz to capture special signals and to interface with computers for automatic processing and analysis. Full remote computer control is used, as well as cartridge tape loads. Head life averages well over 500 hours and over 1000 hours when operated as recommended.

These quadruplex recorders operate reliably at head speeds over 3000 inch/second; however the optimum speed range is in the 1000 to 2000 inch/second range. For over 15 years, quadruplex recorders have been continuously improved to the point where they are among the most reliable information storage devices obtainable.

VERSABIT; A NEW APPLICATION FOR AN OLD STANDARD

A standard quadruplex VTR uses a 0.005 inch track width and yields an FM channel performance of 45 dB pp/rms. The channel performance readily accommodates a 20 megabits/second spectrum with more signal-to-noise margin than is available in other High Density Digital Recording systems. The track width is independent of track spacing, and a large percentage of the tape can be used. A standard Broadcast VTR yields 133 tracks/inch, which is conservative for rotary head recording. This technique, therefore, provides both increased head to tape speed and increased tracks/inch which yields very efficient tape utilization. The application of rotary head techniques combined with a proprietary buffering scheme to high density digital data recording has been called VERSABIT.

1 MILLION BITS PER SQUARE INCH

Selecting a very conservative linear packing density of 10,000 BPI at 133 tracks/inch yields 1.33 MBPI². Allowing for an internal timing track, a time code track, an auxiliary longitudinal track and additional tape allocation for internal recorder use, the 2-inch tape still holds 1.0 MBPI² effective packing density, or 5 times that of standard instrumentation High Density Digital Recording System^[5]. The fact that VERSABIT uses 2 inch tape and High Density Digital Recording uses 1 inch tape is an added 2:1 advantage in tape length required for a specific record time. The end result is that VERSABIT will record at 12 inches/second what High Density Digital Recording records at 120 inches/second. . . . a 10:1 advantage while maintaining a conservative 10K BPI linear bit packing density.

LESS TAPE TO BUY AND STORE

Archiving and recycling needs have a large impact on life cycle operational and tape costs. At 10⁶ BPI² VERSABIT saves 5:1 in tape costs and storage room, or you can carry tape for a 5:1 longer mission. Other operational costs are also significantly reduced.

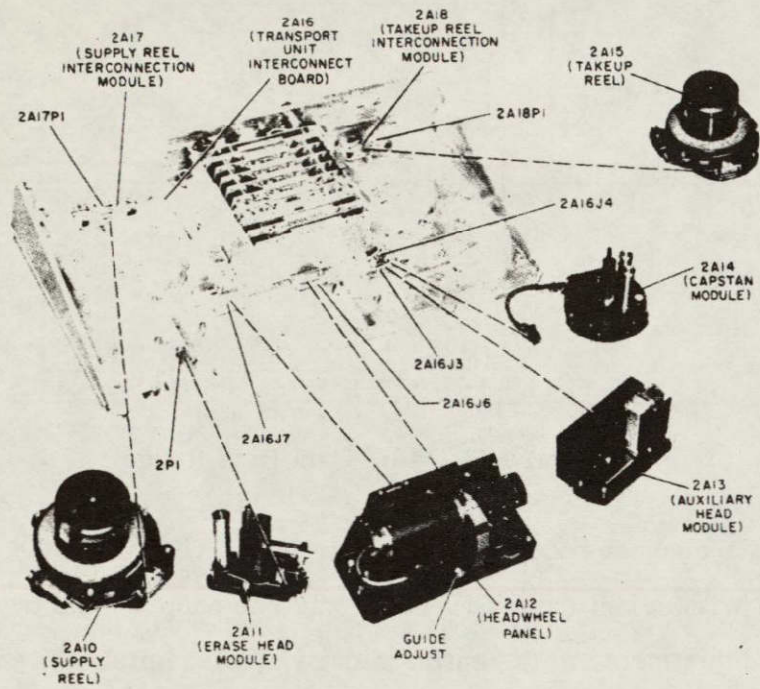

Figure 12. MIL-E-5400 Transport Sub-Assemblies

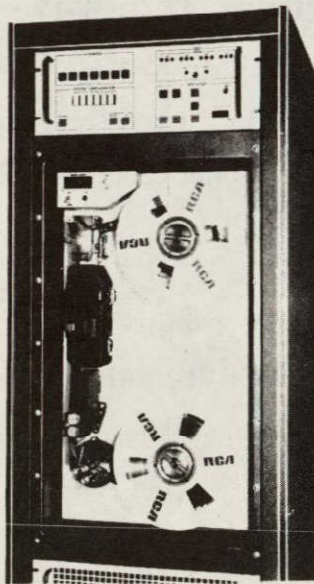

Figure 13. VERSABIT Recorder

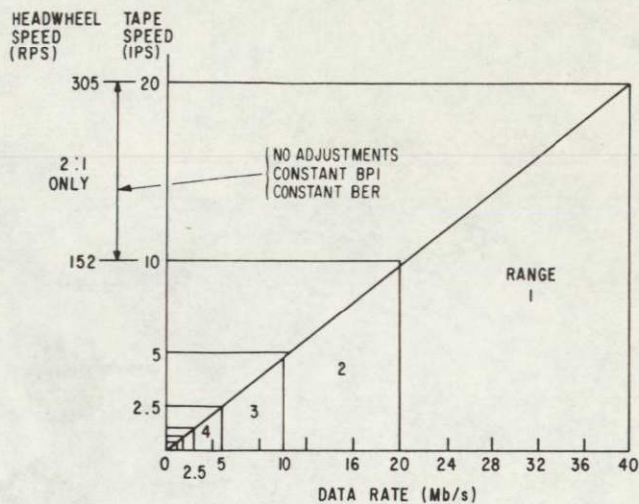

Figure 11. 40:1 Data Rate Range

VERSABIT is a 1-channel recorder which eliminates DEMUX/MUX to get in and out of the recorder with serial data. There is only one encoder and two decoders, and only four field adjustments in the entire recorder, all digital data processing is done in three modules and all the data record/reproduce processing is done in four modules.

The control and servo system is contained in one drawer. These are identical modules as used in the MIL-E-5400 ADVISER - AN/USH-17 recorder. The tape transport is the ADVISER transport. It has one uncomplicated base plate with the six prealigned plug-in mechanical modules shown in Figure 12. Three screws and one plug remove the reel assembly, erase assembly, etc. Assembly replacement time is 4.1 minutes. No alignment required.

VERSABIT has full remote control capability. This coupled with the elimination of all operator knobs (Figure 13) makes VERSABIT an easy to operate push-button recorder. It can even be made a computer peripheral!

VERSABIT PERFORMANCE

The data in Figure 14 shows that the capstan servo can be mistracked ± 20 percent of the standard VERSABIT track width without a significant change in BER. Both the standard 5 Mil track (133 tracks/inch) and 2-1/2 Mil track (266 tracks/inch) are shown.

ORIGINAL PAGE IS
OF POOR QUALITY

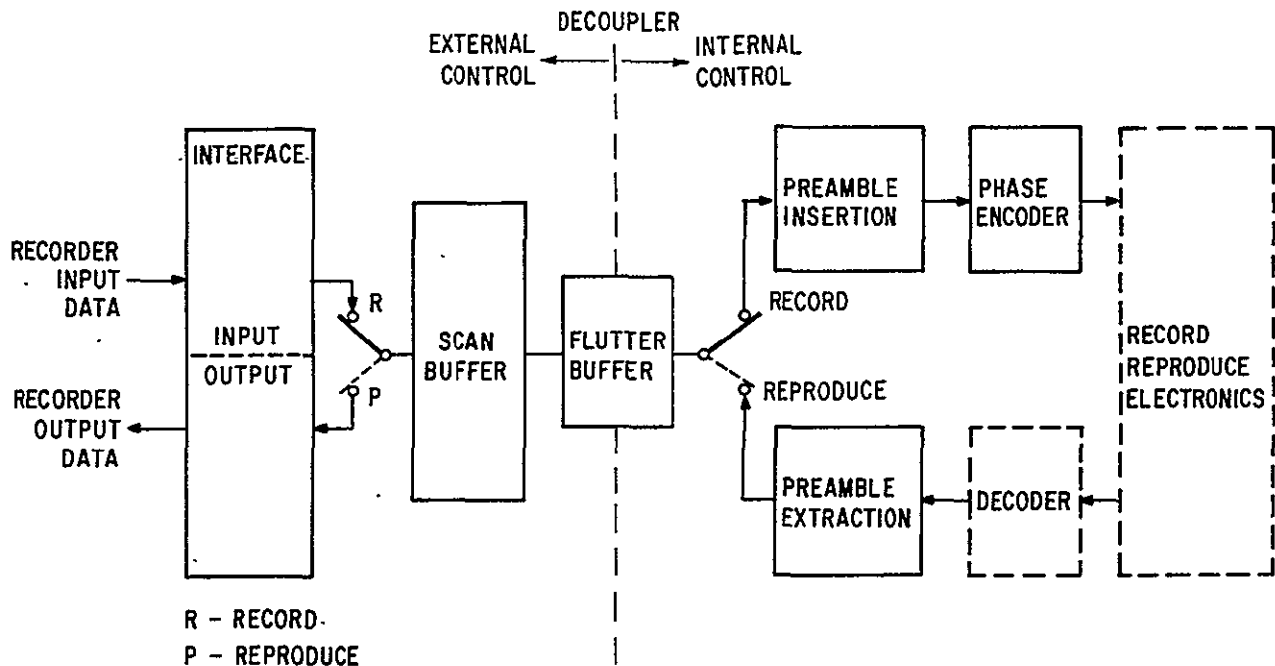

Figure 10. Data Processing Block Diagram

REPRODUCE . The off-tape digital data bursts from the decoder module correspond to the preamble word and data block (16,834 bits) as formatted in the record mode. The preamble recognition circuitry synchronizes the flutter buffer to the data in an ordered fashion. The flutter buffer removes all time base error between the off-tape scan clock and the reference clock. Taking data from the flutter buffer, the scan buffer reconstructs a single data stream at the selected data rate (scan clock rate divided by 2^{N-1} where N is the selected data rate range). Conversion of data and clock to the proper recorder output is accomplished by the interface module.

There are no analog circuits in the record circuitry. There are no equalizers to adjust.

DATA TRANSFER DECOUPLED FROM TAPE TRANSPORT

The transverse scan technique inherently decouples the data from longitudinal tape flutter or time base error. Longitudinal jitter has no effect on the transverse channel signal zero crossings.

ORIGINAL PAGE IS
OF POOR QUALITY

POSITION OF RECORDS
ASA C-98.6

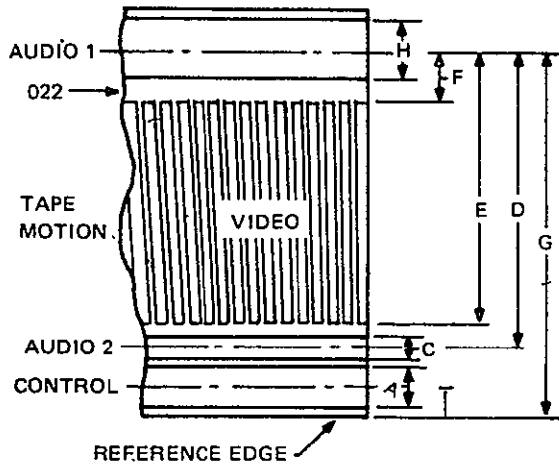

151 BITS LOCK-UP
591 BITS HEADER
16,384 BITS DATA
1,408 BITS EDAC
151 BITS SCAN TOLERANCE

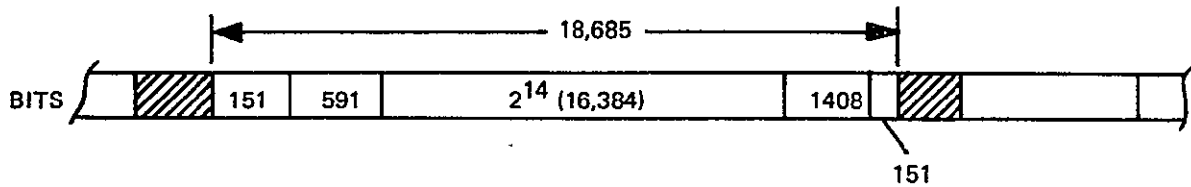

Figure 8. VERSABIT Tape Format Recorded Data Track (ASA C98.6)

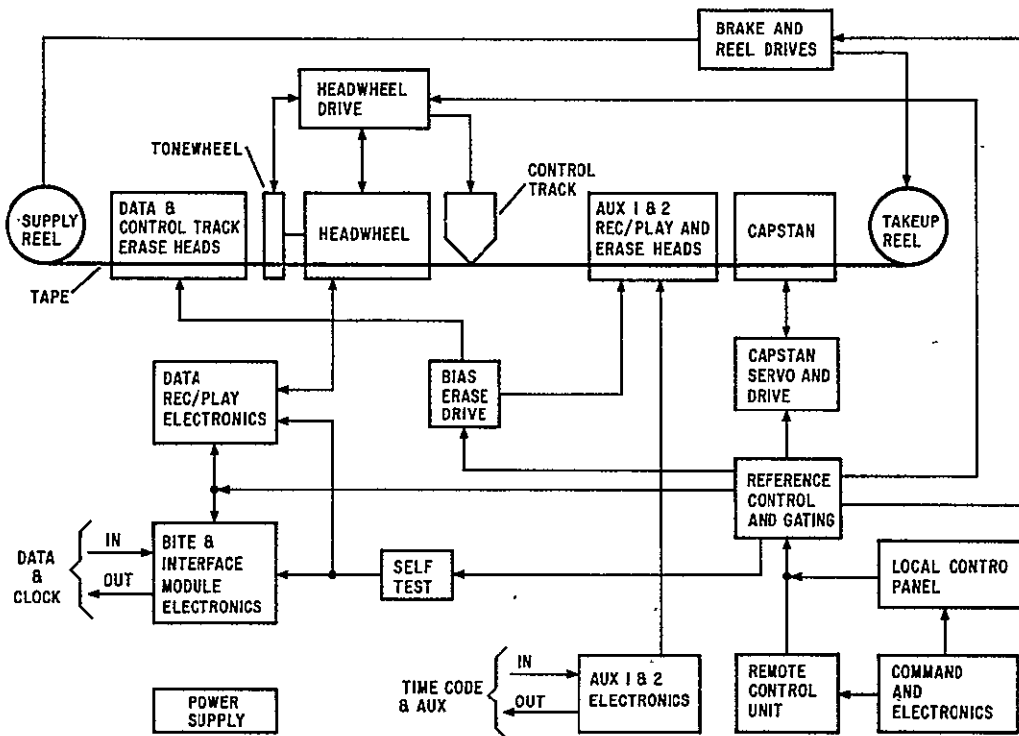

Figure 9. VERSABIT Simplified Block Diagram

ORIGINAL PAGE IS
OF POOR QUALITY

VERSABIT TAPE FORMAT

VERSABIT uses a tape format which has become the standard format for worldwide use in TV, radar, wideband, ELINT and digital applications. The auxiliary (longitudinal tracks) and transverse track format is shown in Figure 8. The VERSABIT utilization of the "video" track is also shown in Figure 8.

VERSABIT blocks 2^{14} or 16,384 data bits on each head scan (swipe) across the tape (At 10,000 BPI, 2^{14} bits of data transfer for every 90° of head rotation). These 16,384 data bits are placed in the center 1.6 inches of the tape. The actual signal burst recorded is 1.8 inches long. The 12 percent overlap provides an overhead capability which is used for data scan framing purposes. Approximately 5 percent is allocated as header/preamble and the remaining 7 percent is allocated to Error Detection And Correction (EDAC). Data is therefore transferred in 2^{14} bit blocks with associated overhead bits. Each block is independently reproduced and one block has no effect on another's performance. Decoupling the recorder internal characteristics from the outside world makes the interface straightforward.

VERSABIT SYSTEM DESCRIPTION

Figure 9 is a simplified system block diagram.

The task of transferring digital data between the VERSABIT user and the record/reproduce subsystem is accomplished by the data processor (Figure 10).

RECORD Recorder input data is received by the interface module and is subsequently loaded into the scan buffer memory for temporary storage. Depending upon the recorder range, data is read from the scan buffer into the flutter buffer where non-coherent requests for scans of data are processed. Each rotating magnetic head requests a 16,384-bit data block preceded by a preamble word when it attains the proper angular rotational position as determined by a tonewheel pulse. The preamble word will be used to identify the data block in the playback mode. Prior to recording, the data is converted from the NRZ format to the enhanced delay modulation code for optimum record/reproduce transfer.

WE FOUR QUALITY

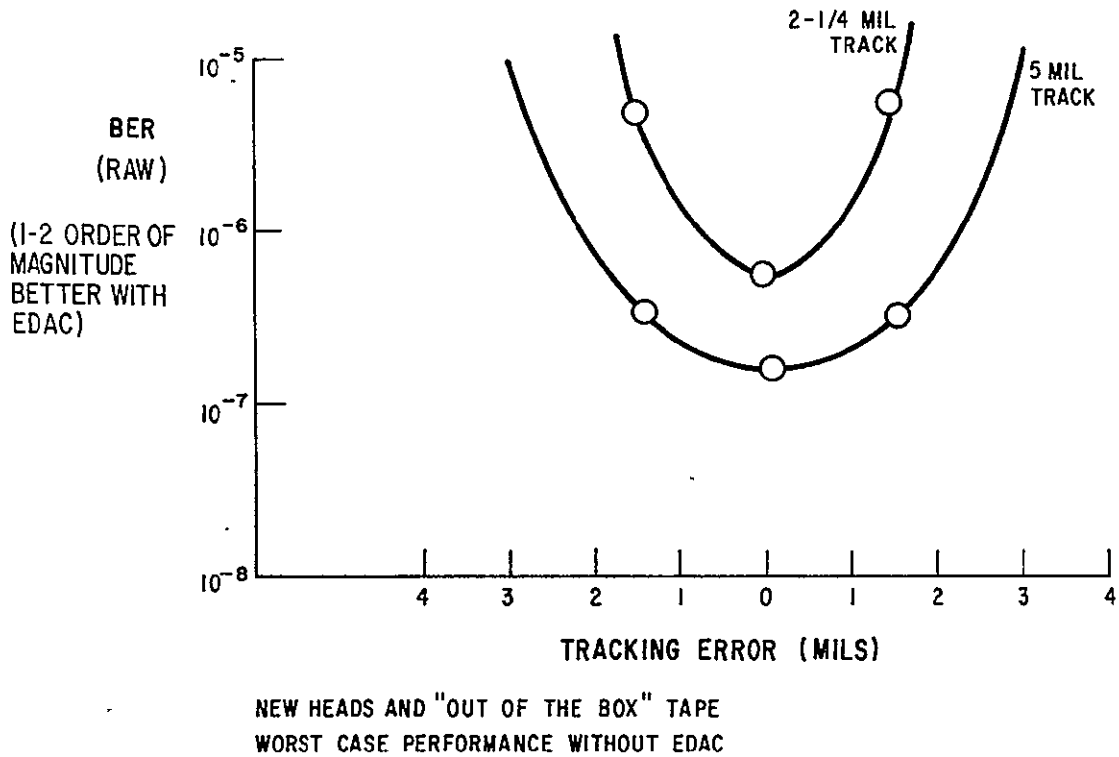

Figure 14. BER Vs. Tracking

ECAC VS S/N MARGIN

All tape systems operate with considerably more channel S/N than the decoder needs for adequate performance (Figure 15). This margin allows use of imperfect tape. The S/N overhead required to achieve a low BER is quit large. If Error Detection and Correction (EDAC) is used, less S/N margin is required, allowing the system packing density to be increased. As long as the EDAC overhead doesn't cancel out the packing density gains, you come out ahead on tape efficiency. If the packing density gain allowance is applied to BPI, the large (>18) dB/octave loss factors allow only modest gains. If the packing density gain is applied to tracks/inch, the gain can be much more striking, because the total track width losses are only 3 dB/octave.

TAPE DROPOUTS

There are two general types of tape dropouts, typical and long. Typical tape dropouts (Figure 16A) are conical in shape with no bottom dwell and typically are 1-5 mils

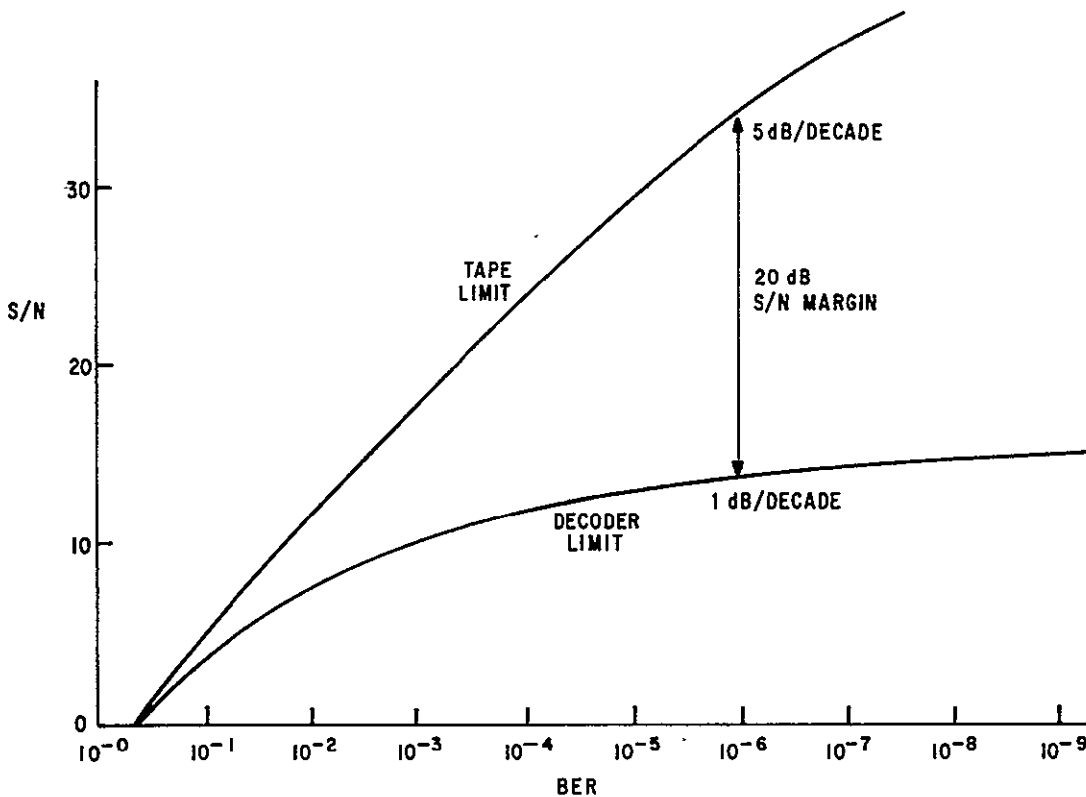
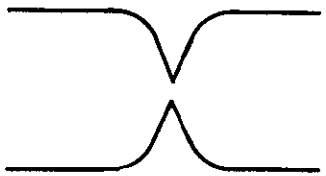

Figure 15. S/N Margin

at -20 dB. Because of this, the dropout rate due to typical dropouts improves at lower signal threshold levels. Long dropouts (Figure 16B) are severe with bottom dwell and typically are 10-40 mils at -20 dB.

Tape which has seen considerable service will exhibit a large increase in small dropouts (1-2 mils) but no change is noticed on the long dropouts for they are generally gross manufacturing defects in the tape as opposed to debris, stipples, and damage which account for the majority of typical dropouts.



OCCURRENCES INCREASE WITH TAPE USE

Figure 16A. Typical Dropout

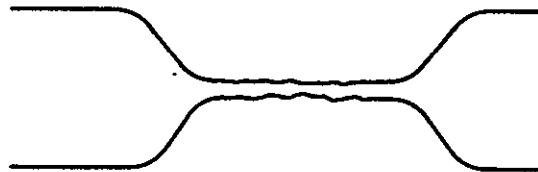

NO INCREASE IN OCCURRENCES WITH TAPE USE

Figure 16B. Long Dropout

DROP OUT SIZE DISTRIBUTION

Data was taken on distribution of dropout size (Figure 17A). At -20 dB, occurrence of tape dropouts was predominant at 3 mils and closely followed a χ^2 distribution for condition $M=5$ [6]. The dropout rate (percent occurrence X size) versus size (Figure 17B) showed that the largest contribution to drop out rate (or probability of error P_e) was at 13 mils.

Statistics obtained from 3300 dropouts show that 99.9 percent of all dropouts were less than 51 mils or 510 bits at 10,000 BPI.

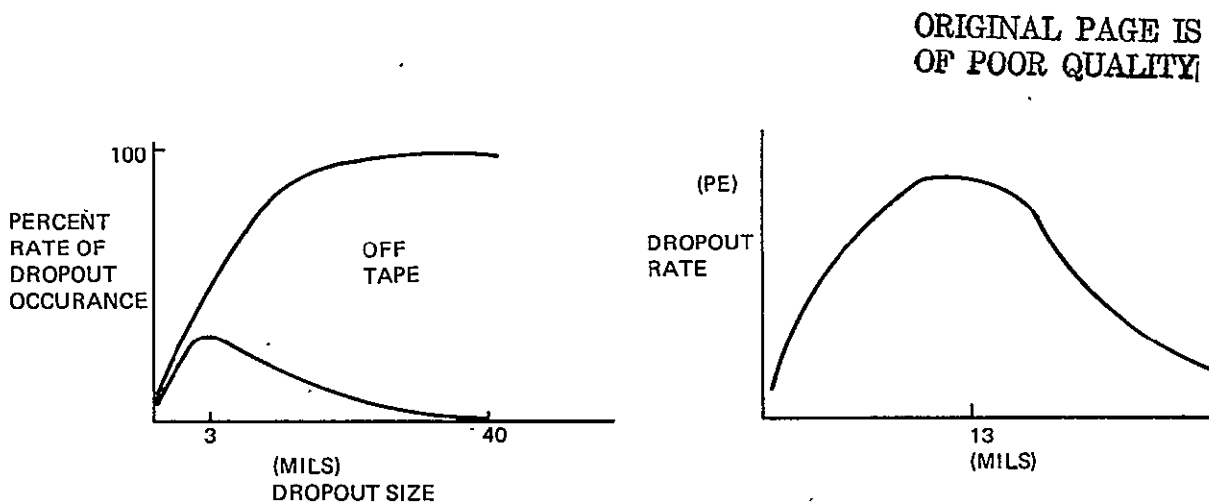

Figure 17A. A Rate of Occurrence Versus Size of Dropouts

Figure 17B. Bit Dropout Rate Versus Size of Dropout

ELIMINATING BURST ERRORS

All tape systems are subject to some long dropouts due to tape imperfections or damage. VERSABIT circumvents the problem of long dropouts which cause long bursts of data error by interleaving the data before it is recorded. That is they are recorded in an order that allows a burst error of up to 512 bits on tape to affect only 4 data bits in a row, maximum, making them correctable with a 4 bit burst EDAC (Figure 18).

This technique also eliminates burst errors from VERSABIT when EDAC is not used.

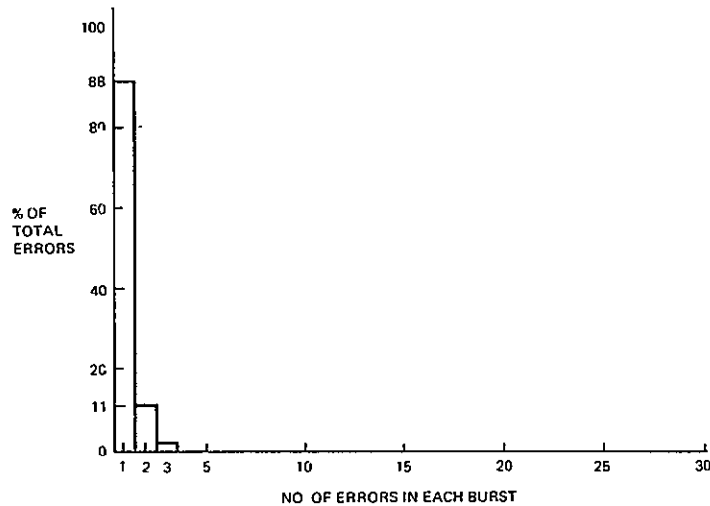

Figure 18. Rate of Occurrence Versus Size of Dropouts After Interleaver

Dropouts longer than 512 bits will exceed the 4-bit EDAC capacity, but are still reduced to a short burst of a few bits which are tolerable to many host systems.

HIGHER PERFORMANCE TAPES

The most recent advances in the VERSABIT technique are with 2.5 mil tracks (266 tracks/inch) and higher performance video tapes. The present VERSABIT system uses standard 3M400 video tape. Other video tapes are available which allow increased performance at twice the packing density.

To obtain knowledge for prediction of system performance versus tape types and track width, tape dropout profiles (Figure 19) were taken on two standard video tapes, 3M400 and 3M361. Signal dropout rate was measured versus threshold level setting of the dropout detector. These data show the effect of system performances versus S/N margin where S/N margin is the difference between tape S/N and decoder threshold S/N at any given dropout rate.

HIGHER BPI³ SYSTEM

When the dropouts are relatively steep sided (dB/mil), the dropout rate is nominally equal to the probability of error (Pe) which is related to BER by a factor of 2:1 (BER = 0.5 Pe).

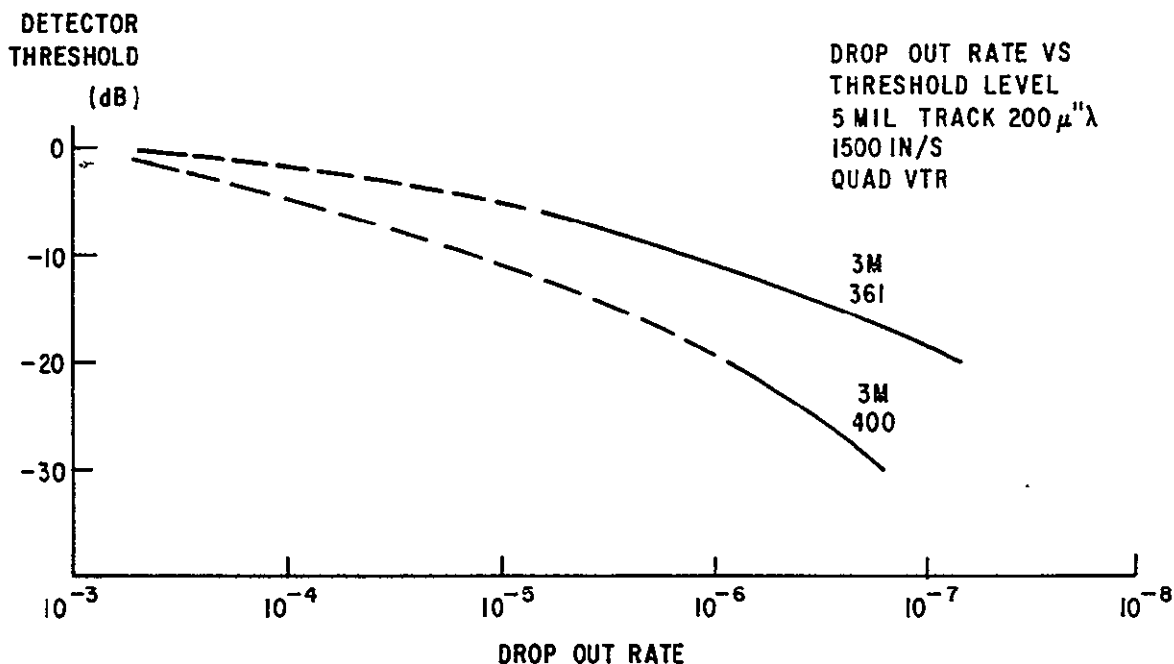

Figure 19. Dropout Rate vs Threshold Level

For a decoder threshold S/N at -20 dB, the standard VERSABIT dropout rate is approximately 10^{-6} (and the BER is about 5×10^{-7}). Use of the higher performance tape (Figure 19) yields a 10:1 improvement in dropout rate or 9 dB of S/N margin over the present system. At 3 dB loss per half-track width, the track width can now be reduced to 1/8 the present 5 mil or to 0.625 mils (1,600 tracks/inch) and still maintain 10^{-6} BER. Preliminary tests with 10, 5 and 2.5 mil tracks confirm this assertion (VERSABIT units with 2.5 mil tracks (2×10^6 BPI²) are now being built.)

An additional advantage to the 361 class of tapes is that they are available in 0.8 mil total thickness. For the next generation of VERSABITS, the area density can be as high as 10^4 BPI \times 1.6×10^3 TPI or 1.6×10^7 BPI² and the volume packing density 2×10^{10} BPI³. For a standard 10-1/2 inch reel of 2-inch tape (1.6 inch used) the storage capability is 2.4×10^{12} bits/reel (nearly 2-1/2 terabits). This is a record time of 33 hours at 20 megabits/second on a 10-1/2 inch reel of standard video tape.

ORIGINAL PAGE IS
OF POOR QUALITY

CONCLUSION

The development of a one reel of tape multi-terrabit mass memory system in a one rack configuration (Figure 20) is close at hand. The applications and performance of such a system is summarized in Table 2.

TABLE 2. VERSABIT APPLICATION AND PERFORMANCE SUMMARY

<u>Applications</u>	<u>Performance</u>
● Mass Data Storage	● Reads Tape Noise at all Transfer Rates
● Fast Access	● 2:1 Transfer Rate Limit
● Rate Change	● 40:1 In/Out Rate Range
● Block Data Transfer	● LO BPI - HI BPI ²
● Cartridge System	● 1 or 2 Channels
● Computer Control	● EDAC
● Space, Air, Ground, Sea	● Search at 200 MB/S

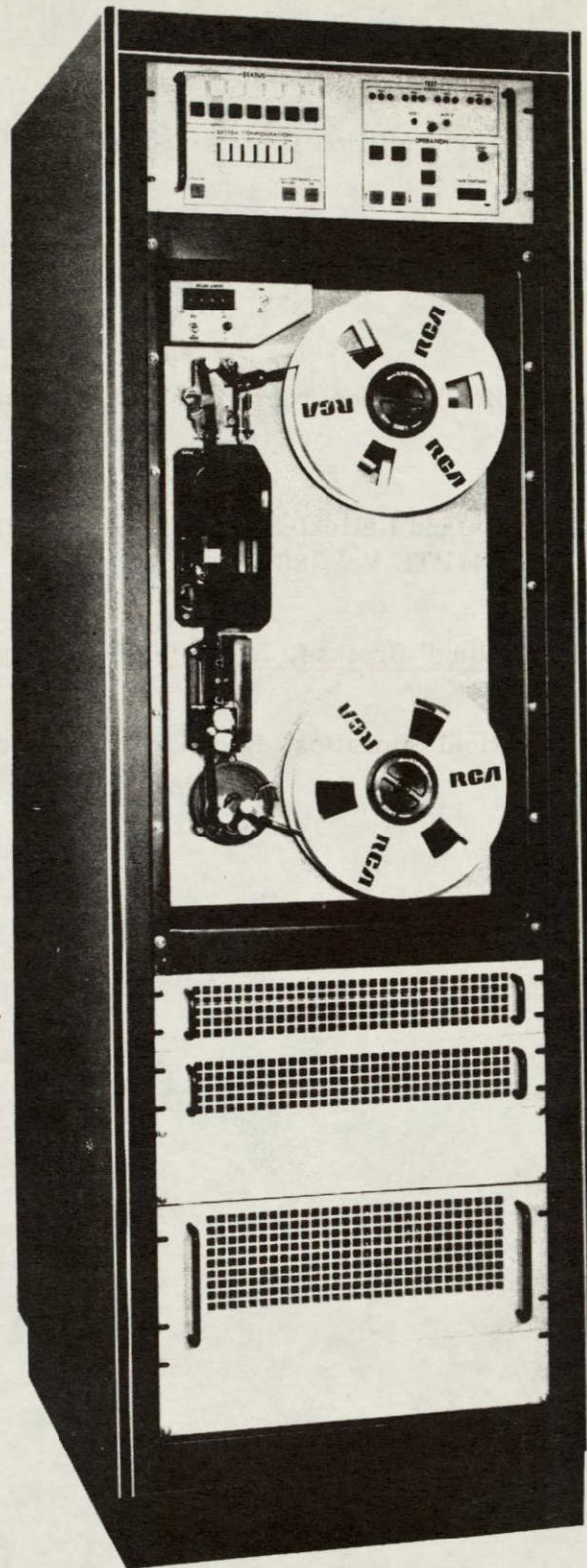

ORIGINAL PAGE IS
OF POOR QUALITY

Figure 20. VERSABIT High Density Recording System

REFERENCES

- [1] "Digital Data Recording at Five Million Bits per Square Inch" Thompson, C.R., Waring, J.L. ITC '75
- [2] "A High Capacity, High Data Rate Instrumentation Tape Recorder System" Bessette, O.E., ITC '73
- [3] "NASA Standard Spacecraft Tape Recorder" A.M. Burke and F.L. Putzrath, ITC '76
- [4] "An Analysis of Quadruplex and Helical-Scan Video Recording" Grever, J.L. Feb. 1974 Journal of the SMPTE Vol. 83
- [5] "High Density Data Recording" Breikss, I.P., IEEE Spectrum, May 1975
- [6] "Introduction to Mathematical Statistics" Hoel, P.G. 2nd Edition, 1954, Wiley pp 166-7, 216

The Research and Engineering News Digest

RCA at the 1976 NAB Convention . . . On the following pages are described some of the equipment and systems exhibited by Broadcast Systems at the 1976 National Association of Broadcasters Convention held recently in Chicago, Ill.

High-Density Video Recording System

One of the highlights at NAB was a demonstration of RCA's new method of high-density video recording that combines laser and optical technologies to make it possible to store as many as 10,000 TV pictures on a single, 12-inch disc. The method demonstrated is distinct from the RCA "SelectaVision" VideoDisc system which uses a capacitance pickup technology especially developed for home use.

The technology demonstrated for broadcasters is a joint development by research and development teams at RCA Laboratories and Commercial Communications Systems Division. In the demonstration, RCA engineers used laboratory-built equipment under minicomputer control to show how the stored TV pictures can be randomly accessed and displayed in a fraction of a second.

Neil Vander Dussen, Division Vice President, Broadcast Systems, said the developmental system can store one frame of TV information in only 0.003 square inch. "Contrast this space usage with today's standard video recording method for broadcasting which requires one square inch of magnetic tape for each frame. The improvement in packing density is 300 times," Mr. Vander Dussen said.

While the NAB demonstration covered only still pictures, the RCA technology also is capable of recording motion, from film, video tape, or live sources. Some years in the future, a TV station could broadcast an entire day's programs from disc recordings.

In making a recording, the demonstration equipment employs a medium power laser, modulated by an electro-optic modulator which is focused to a very fine spot on the disc, spinning at 1,800 revolutions per minute. The disc has a special thin-film coating

which, when affected by the laser, provides a permanent recording of a single TV frame in one revolution of the disc.

Movement along the disc radius is accomplished by a mechanical actuator, permitting rapid access to the approximate location of the desired recorded track. Precise location is possible through an electronic servo system to deflect the laser beam.

The demonstration equipment operates two laser stations, one positioned either to record or playback while the other is simultaneously reproducing information from other tracks. In a broadcast situation, continuous output, therefore, is practical.

The system's minicomputer keeps track of the pictures in storage and controls the preparation of picture sequences for broadcasting. Stored pictures can be identified by number or name, and the computer will handle up to 16 alphanumeric identification characters per picture.

While the system is "on the air" its computer memory can be interrogated as to what pictures are in the file. The system also will call up and display on demand all pictures in a given category, such as U.S. presidents, sports, etc.



Lee Hedlund, RCA project engineer, loads company's developmental video recording system that is capable of storing 10,000 TV pictures on a one-inch band of the disc.

Optical Video Disc Recorder

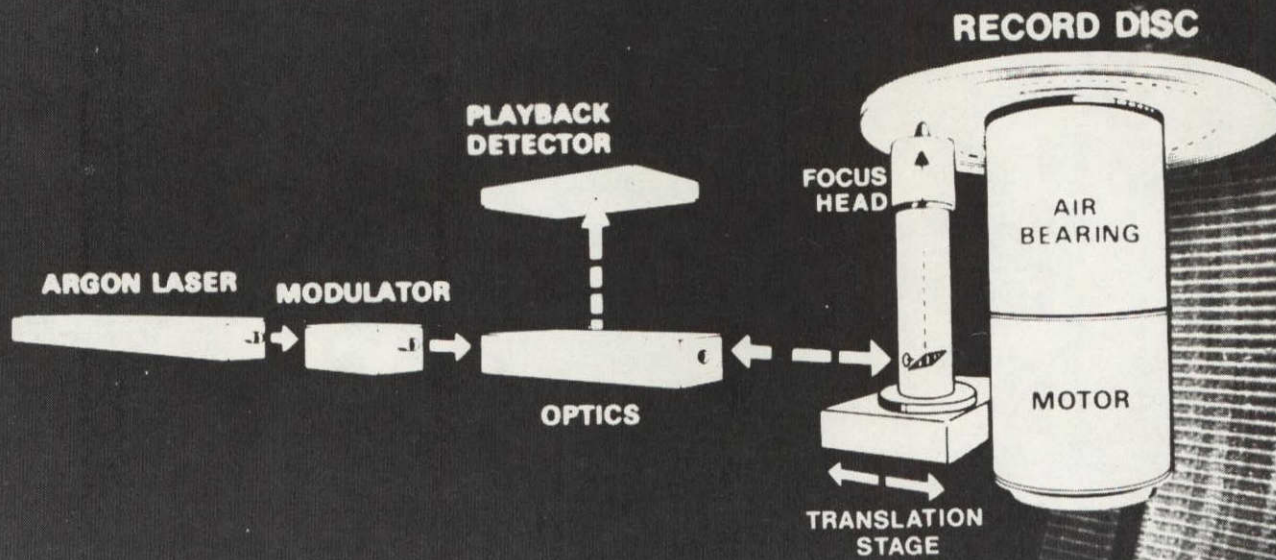

ORIGINAL PAGE IS
OF POOR QUALITY

ORIGINAL PAGE IS
OF POOR QUALITY

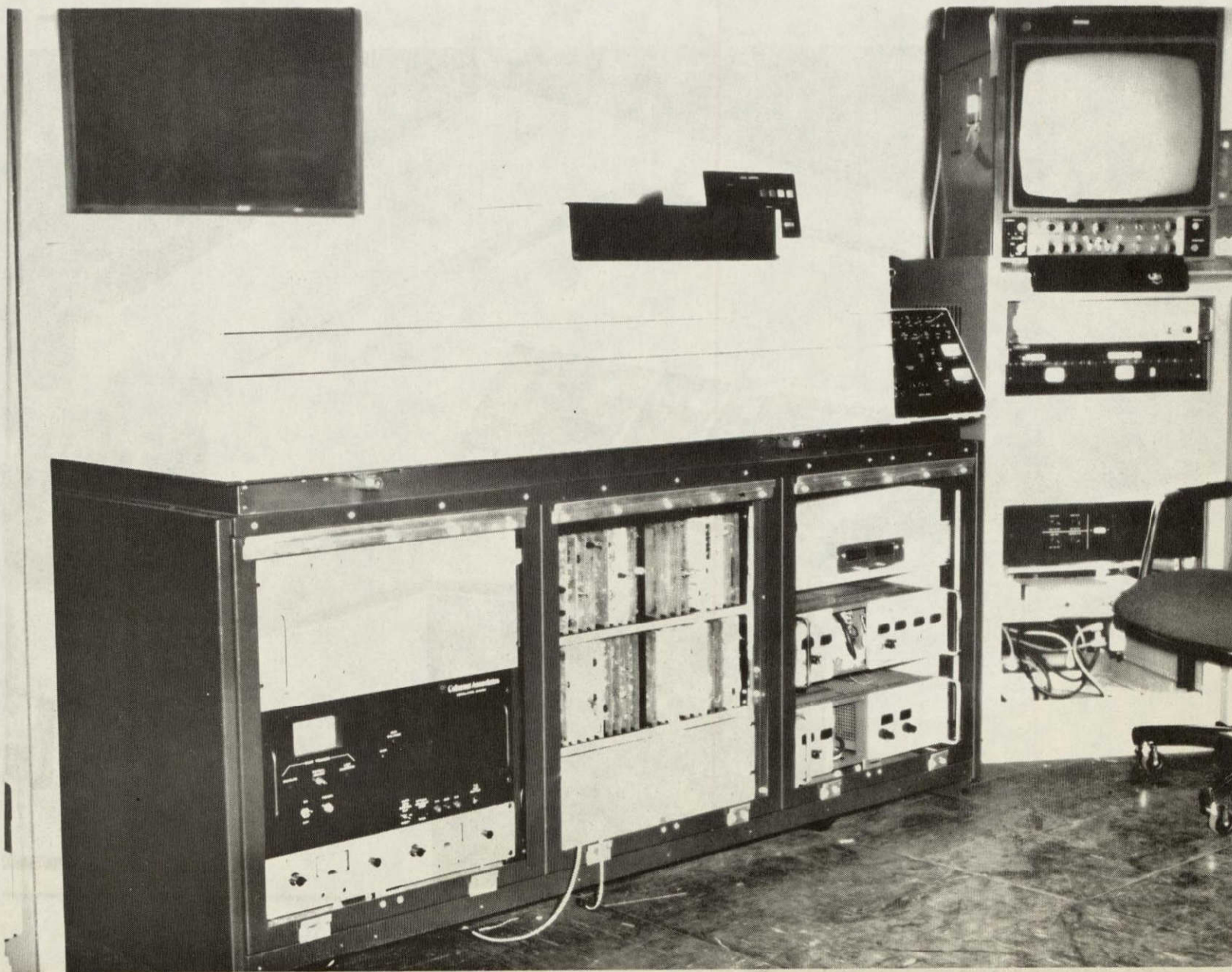

RCA OD System - Engineering Model

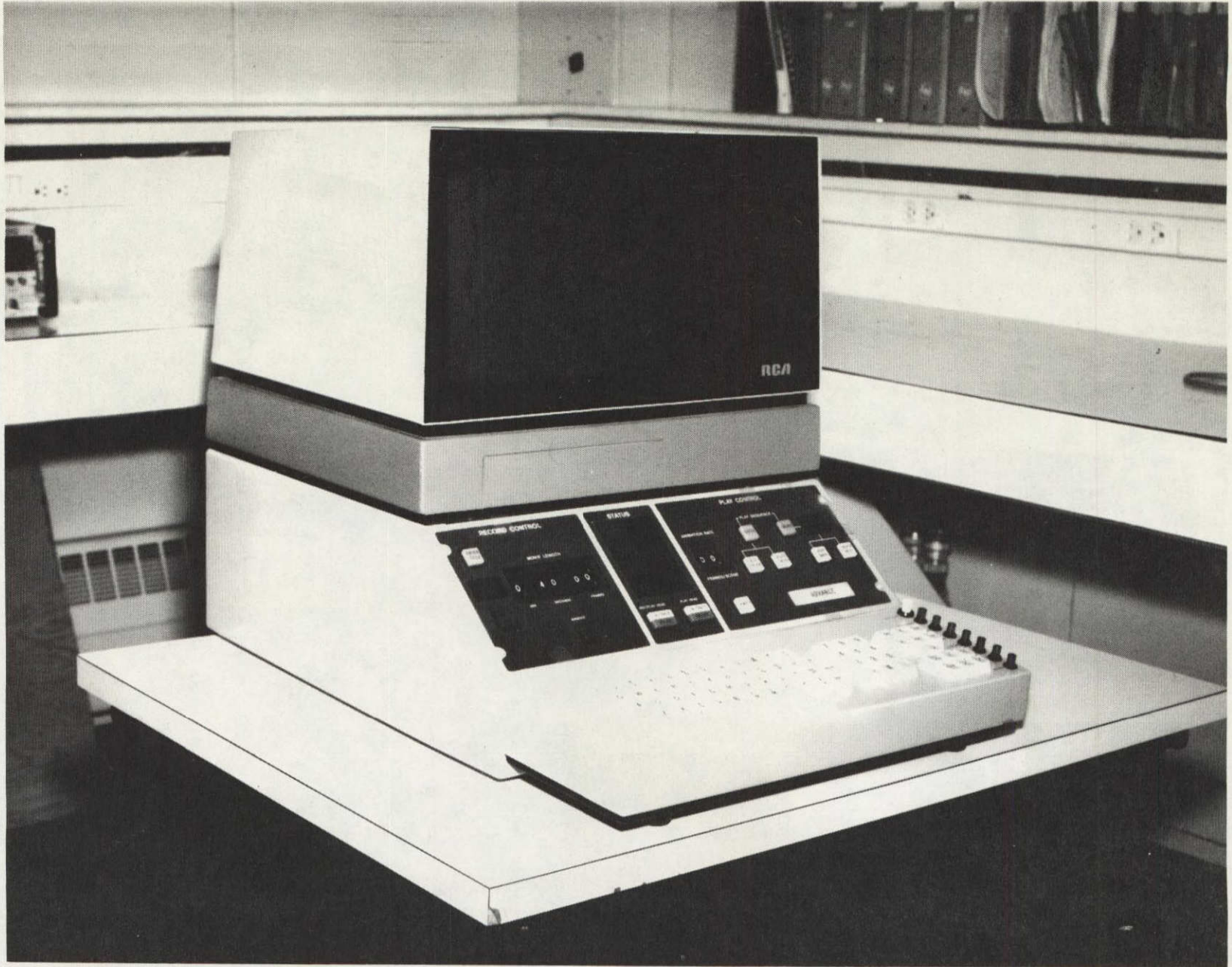

RCA OD System - Control Console

NO. 10011
ORIGINAL
1/17/50
05/12/57

ORIGINAL PAGE IS
OF POOR QUALITY

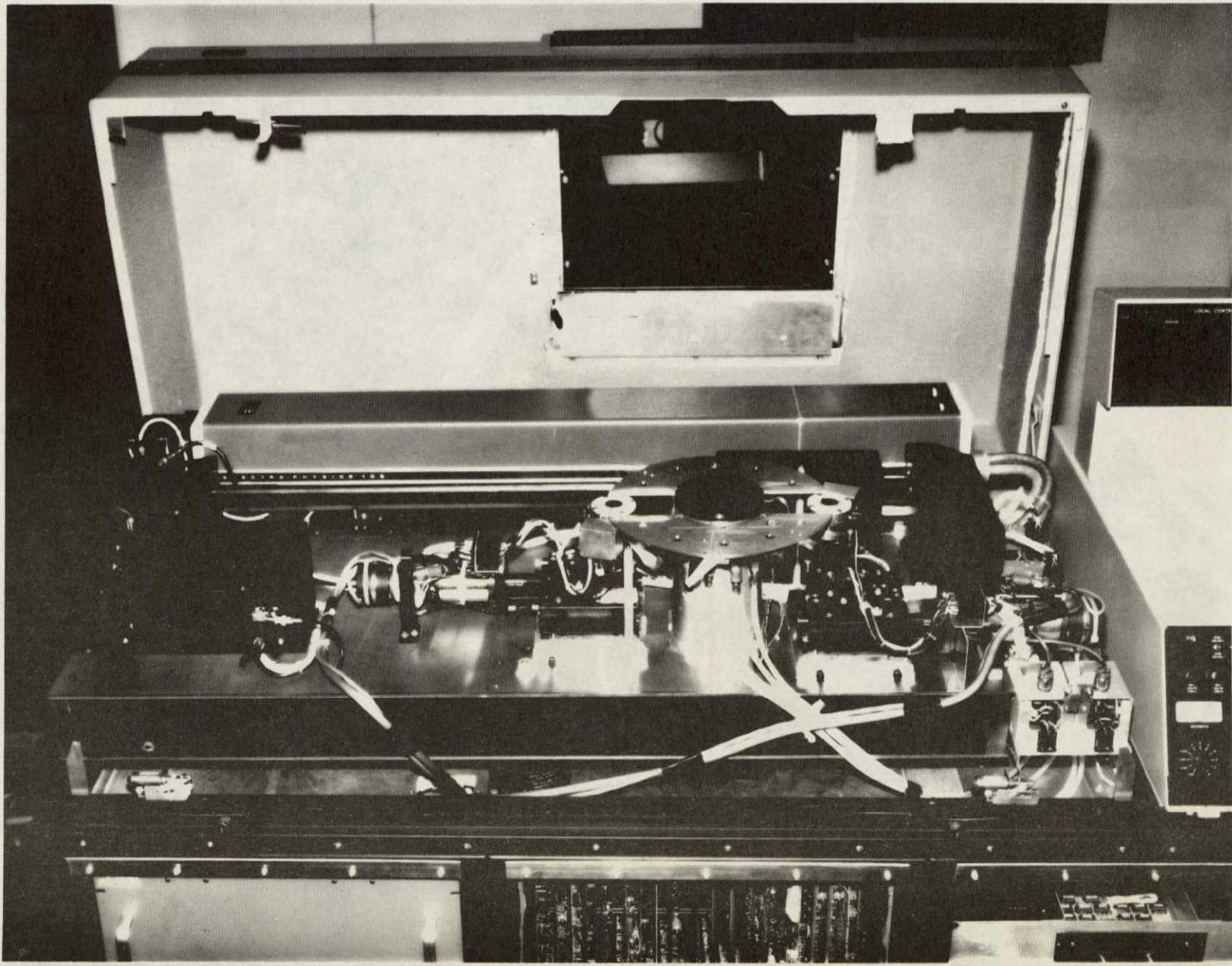

RCA OD System - Mechanism

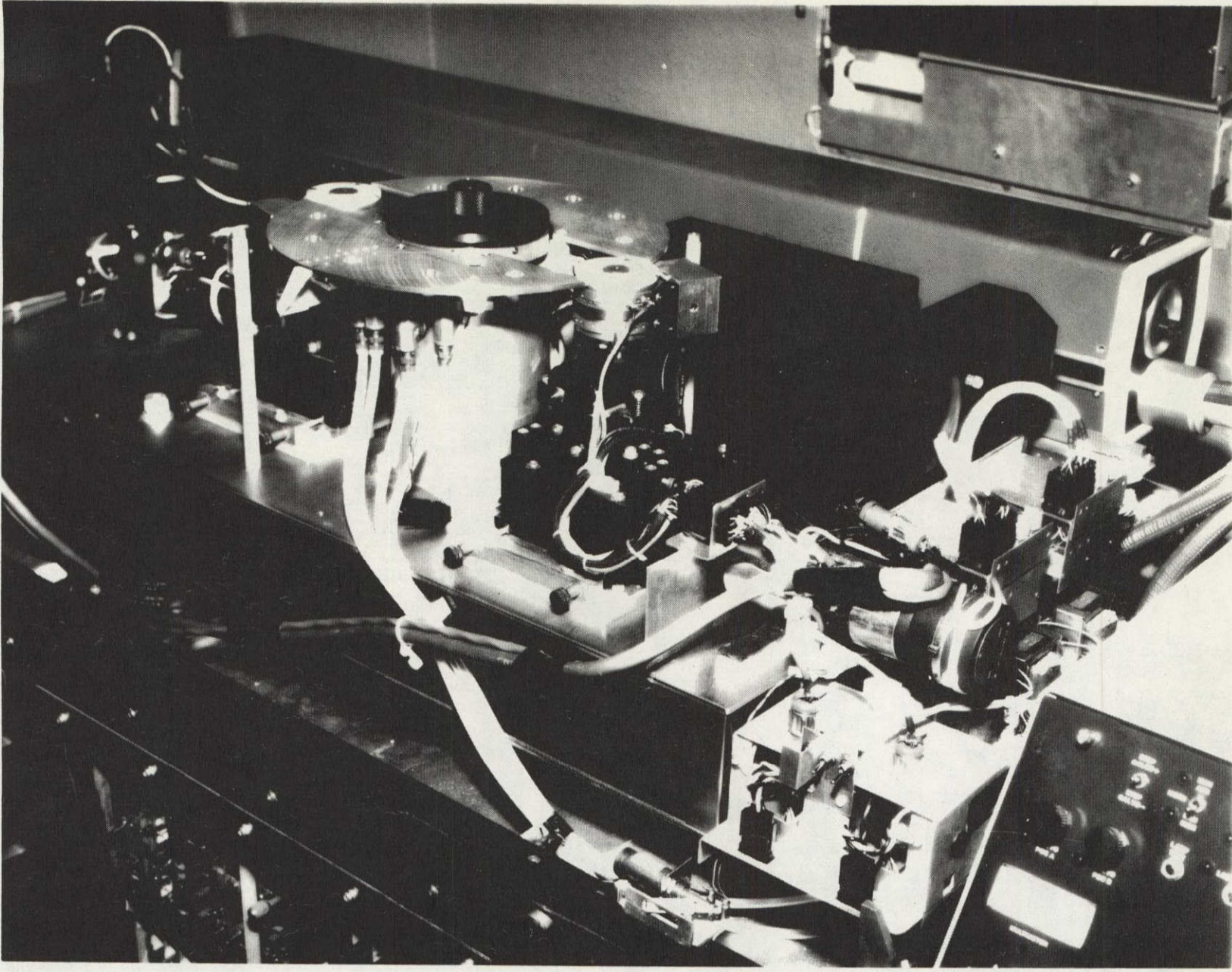

ORIGINAL PAGE IS
OF POOR QUALITY

RCA OD System - Mechanism

TABLE 1. COMPARISON OF RCA VIDEO DISC SYSTEMS

Parameter	Home Entertainment	Optical Video Disc
Record	Electron Beam	Laser Beam
Media Processing	Master-Stamp	None
Playback	Mechanical (capacitive)	Laser Beam
Bandwidth	3 MHz	5 MHz + 30 MHz
Signal-to-Noise Ratio	40 dB	50 dB
R/MIN	450	1800 (nominal)
Playing Time	One Hour.	30 Minutes
Stop Action	No	Yes
Tracking	Mechanical (grooves)	Servoed Galvanometer
Focus Control	None	Servoed Lens

TABLE 2. USES AND ADVANTAGES OF RCA OPTICAL VIDEO DISC TECHNIQUE

USES	ADVANTAGES
<ul style="list-style-type: none"> ● TV Recording (50 dB, 30 minutes/disc) ● Continuous Video (analog 30 MHz potential) ● High Data Rate Digital (200 Mb/s) ● Mass Data Store (10^{11} bits/disc) ● Electronic Newspaper 	<ul style="list-style-type: none"> ● Rapid Access to Data (<1 second within disc) ● Disc Info Can Be Updated ● Storage Media Cost Savings ● Compatible with Automation ● Single Frame or Continuous

RCA has been pursuing further development of the OVD system for both the high-quality video and digital-data storage applications. The RCA Laboratories, Princeton, NJ, have both company-sponsored and Government-supported programs for improving video disc material. The RCA Advanced Technology Laboratories in Camden, NJ, has assembled the OVD record/playback system shown in Figure 2 to explore digital-data storage and other Government needs.

OVD System Description

The system functional diagram (Figure 1) applies to both analog and digital storage systems. The record disc is placed on a turntable which is supported by a high-precision air bearing. Recording is accomplished by exposing the disc to the modulated laser radiation, which is passed through beam-forming optics and directed towards the disc by the track mirror. The laser beam is focused onto the disc to form a series of very small spots, whose spatial relationships are determined by modulation.

Since the optical system has a very short depth of focus, constant repositioning of the focusing lens is required to keep the laser spot focused onto the microscopically uneven disc surface. The focus servo accomplishes this task by sensing the distance between the focus lens and the disc surface and then driving an objective lens mounted on a speaker type coil to maintain this fixed distance.

The position of the laser spot on the disc is determined by the position of the track mirror. This position during record is determined by the motor-driven translation stage. The control logic can move the translation stage so that either a spiral or a circular track can be traced.

During playback the laser power is reduced by changing its operating mode, and the illumination level to the disc is held constant by the optical modulator. Light reflected from the recorded disc passes back through the focus lens, track mirror, and optics to the avalanche photodetector.

Here again the translation stage is used to determine what portion of the record is played back. The translation stage provides control of the readout laser's position on the disc to the nominal track position. Since the tracks were not recorded as perfect circles, a small amount of disc runout occurs as a result of removing and imperfectly replacing the disc. Finer tracking control is obtained by a dither track servo, which wobbles the track mirror to modulate the position of the readout laser beam. This wobbling introduces modulation into the detected return signal, and is used to close the loop and to keep the optics aligned to the center of the recorded track.

The record and playback signal-processing electronics determine the storage format and the type of information that is stored. Since the recorded information is in a series of spots (determined by laser modulation), information is coded by variations in the local arrangement of the spots. In the case of analog video, information is impressed by an FM coding scheme.

Optical System

The optical system for the experimental testbed is illustrated in Figure 3. In the record mode, the modulator and focus servo functions are used, but the tracking galvanometer and avalanche detector are not. The laser beam, modulated by an acousto-optic modulator, passes through a half-wave plate which is rotated to select the signal amplitude for recording. The beam then passes through the polarizing beamsplitter and a quarter-wave plate.

The modulated laser beam is expanded so that it can fill the focus lens and then reflect from the mirror mounted on the tracking galvanometer. The beam passes through the focus lens and is focused on the record surface. Focus is maintained by the capacitive sensing focus servo.

During playback, the modulator is held at fixed drive to keep the laser output at a constant level. The focus servo holds the record in focus, and the tracking galvanometer is used to follow the track. The avalanche detector detects the light reflected from the record and then provides the electrical playback signal. The quarter-wave plate and the polarizing beamsplitter form a combination that has the property that light passing through the polarizing beamsplitter and quarter-wave plate and reflected at the right side of Figure 3 (without any induced change of polarization in reflection) will be wholly reflected to the avalanche detector on its return. Thus, during playback where a lower light amplitude is employed, the laser beam follows the same path to the record as in the record mode. Light reflected from the record is collected and collimated by the focus lens. It passes back through the optical system to the avalanche detector, and the electrical signal generated is passed to the playback electronics.

Digital-Data Recording

Use of the optical video disc system for recording digital information requires the optimum selection of modulation, coding format, and error detection and correction (EDAC) codes. Information is recorded on the OVD as a two-level signal (binary coded), due to the fact that recording is accomplished by using the "write" laser to remove material from the disc. The recorded signals are formed in a series of spots of varying length and spacing. Therefore, pulse coding must be employed to efficiently store information on the disc, and a complementary form of decoding must be used to recover the information during playback.

Figure 4 is a block diagram of the general signal processing that would be used in recording and playing back digital data on the optical video disc. Serial input information must first be buffered to accommodate nonsynchronous data entry and then formatted into appropriate data blocks. The buffering handles both asynchronous data and data rates lower than the maximum rate of the OVD. Data blocking and the addition of appropriated header information facilitate organizing the data into convenient segments for addressing and error control.

The next step in the signal processing adds error detection and correction information. This step is most important in digital recording systems where bit error rates (BER) of 10^{-7} and lower are desired.

The objective of EDAC is to recover the original input data even though in the process of recording, storing and/or reading the data, various undesired changes have been made in the data. In record mode, check bits are added to the data and the resulting information is redistributed with respect to itself. In some EDAC systems a 1000-to-1 improvement in BER can be achieved with check bits comprising only a 10% overhead.

The next step in the signal processing encodes the information for recording onto the OVD. Several encoding formats have been developed which we are currently examining for applicability to the OVD system. Some formats require the addition of timing information to ensure proper decoding

ORIGINAL PAGE IS
OF POOR QUALITY

upon playback. The encoding portion of the system can also be set up to feed the data into the disc on parallel tracks. The number of tracks used here can be different than that used in demultiplexing and EDAC.

Retrieving information recorded on a disc involves performing the inverse of the processing used for recording. Information read out of the tracks is first decoded to yield the basic input information with EDAC bits. Timing information obtained during playback is fed back to the disc drive to adjust rotational speed for optimum readout. The EDAC circuitry checks the information out of the decoder and corrects the errors within the capability of the EDAC code. Finally the signals out of the EDAC circuitry are stripped of the EDAC bits and fed to the multiplexer for recombination into the original input data format.

Modulation and Coding

Selection of the data format which is optimum for high density, high data rate, and low BER requires determining certain characteristics of the basic record/playback mechanism. Figure 5 is a plot of relative output vs. frequency for the RCA-proprietary optical video disc. The solid curve represents the theoretical response (on the basis of system physical and optical parameters), and the data points represent test measurements. The curve is for a disc rotational speed of 30 r/s. Higher speed will produce wider bandwidths but not necessarily with a one-to-one correspondence.

The signal-to-noise characteristics of the optical video disc are also important parameters to be factored into a system design. Present discs exhibit exceptionally high SNR of about 50 dB. These measurements were made by using an FM recording scheme, with the carrier at 9 MHz and a video bandwidth of 6 MHz. Disc speed was 30 r/s, and the SNR was measured at the demodulator output. Some measurements have been made by using a 20-MHz carrier, and results indicate an SNR higher by about 3 dB. Since the record noise is essentially in the form of jitter in the edge definition of the recorded slot, it has the triangular shape characteristic of FM systems. The SNR directly out of the disc has not been characterized, but observations of output signals indicate an edge jitter of less than 1 ns peak to peak. The disc noise does increase at low frequencies so it is not desirable to use a modulation scheme which requires dc or low-frequency response.

In our work at RCA, we are investigating coding approaches to identify the optimum scheme. The encoding techniques which appear most applicable are PSK, PAM-FM, multi-track NRZ, and delay modulation. Although the scope of this paper does not permit thorough discussion of tradeoffs, it is appropriate to describe some of the important features of the leading candidate: multilevel phase-shift keying.

Figure 6 shows both the time-domain pulse waveshape and the frequency spectrum of a 4-bit PSK code. In this approach, the incoming data is split into groupings of 4 sequential bits and encoded into one of 16 phases of the basic carrier. In the examples shown, the data rate is 50 Mb/s, the carrier is at 12.5 MHz, and the phase deviation (keying range) is about ± 1 radian. The spectrum of such a waveform extends to 25 MHz, as shown in the frequency plot of the sidebands. Thus, a 25-MHz response off the disc is required to incorporate this approach.

The signal-to-noise considerations are also shown in Figure 6. To achieve a BER of 10^{-5} an SNR of 4 to 1 is required for binary PSK. Taking into account the deviation and the multiple levels requires an additional SNR of 48 to 1. Thus, an overall SNR of 192 to 1 (about 46 dB) is required when the 4-bit PSK approach is used. Since the RCA disc has more than 50 dB SNR, it would appear that there is a good fit when this scheme is used. Further analysis and tests are required to verify our selection.

We are concerned about developing the optimum coding scheme because it will ultimately lead to a system having the highest bit-packing density and the lowest cost/bit. We believe that eventually a cost of 10^{-8} cent/bit is possible for the OVD storage medium.

Conclusion

The ultra-high packing density, wide bandwidth, and high signal-to-noise capability of the RCA optical disc, coupled with its potential for ease of handling and instant record and playback, have

made the system attractive for many information storage applications. The effort to develop the techniques necessary for high data rate digital recording is just starting. Our research is concentrating on how to make best use of the disc's unique properties of signal-to-noise and packing density. We see the high data rate application paving the way for other uses of the OVD, such as mass data archives, electronic newspapers, expanded memory for mini- and microprocessors, as well as the traditional role of the OVD as a television device.

References

1. R. A. Bartolini, H. A. Wrakliem, and B. F. Williams, Opt. Eng. 15, 99 (1976).
2. A. E. Bell, R. A. Bartolini, A. Bloom, and F. W. Spury, Optical Soc. of Am. Annual Meeting, Toronto, Canada, Oct. 1977.

ORIGINAL PAGE IS
OF POOR QUALITY

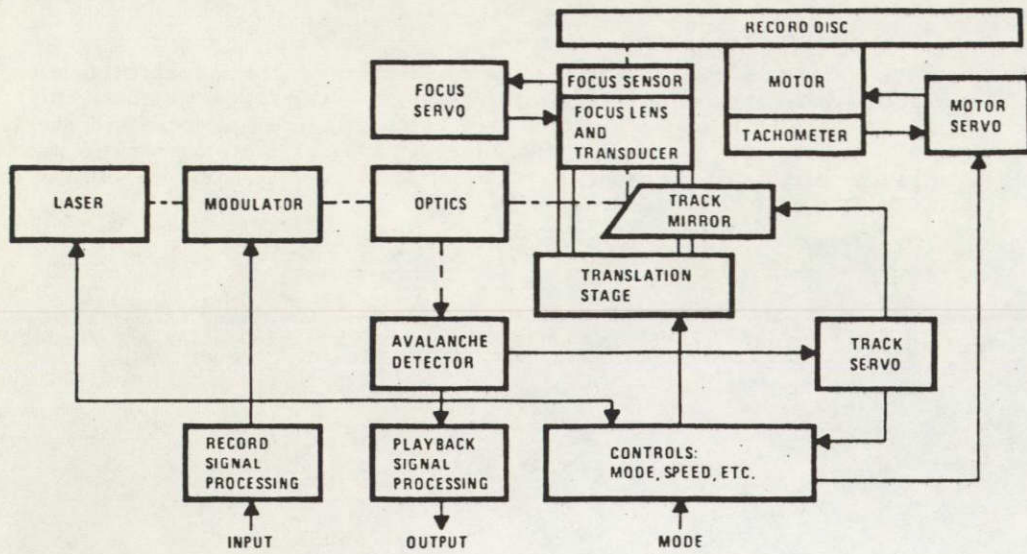

Figure 1. RCA optical video disc system.

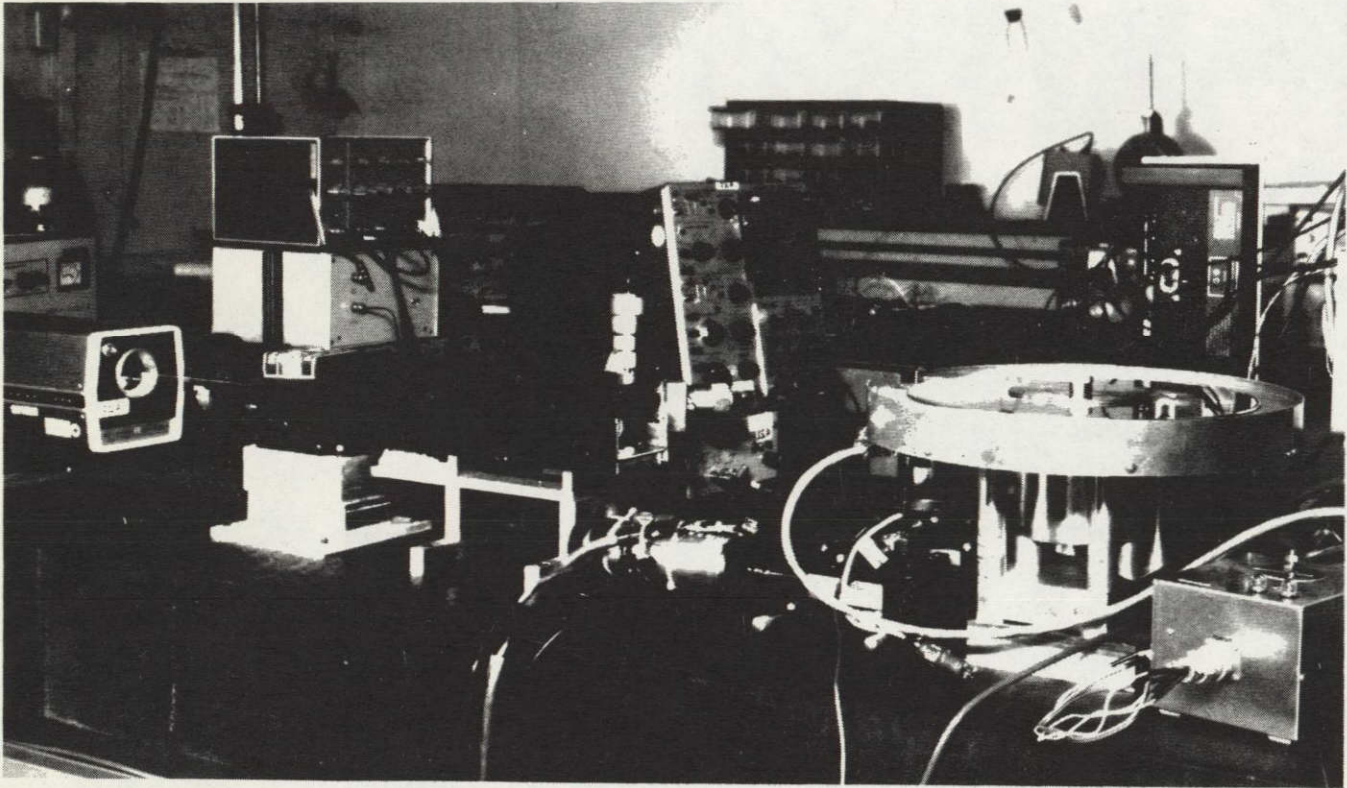

Figure 2. Experimental OVD setup.

ORIGINAL PAGE IS
OF POOR QUALITY

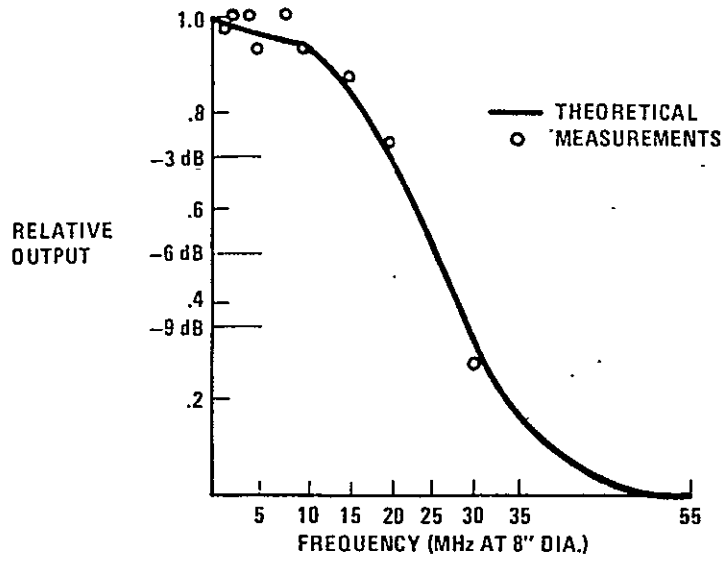

Figure 5. Frequency response of RCA OVD.

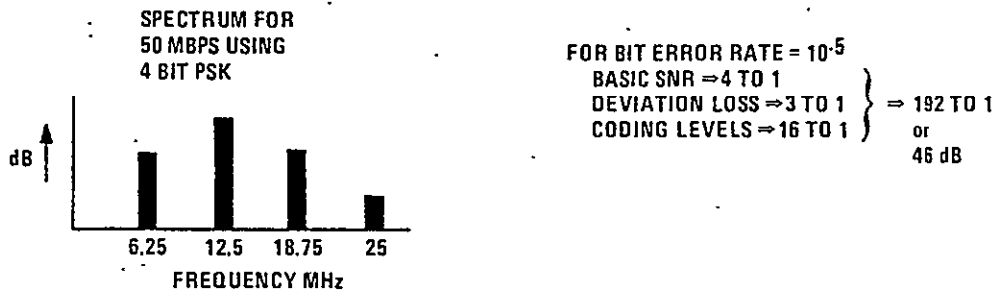

Figure 6. Multilevel coding considerations.