

(NASA-TM-73762) BASELINE TESTS OF THE EVA N78-17939
CONTRACTOR ELECTRIC PASSENGER VEHICLE (NASA)
57 p HC A04/MF A01 CSCI 13F

Unclas
G3/85 04464

BASELINE TESTS OF THE EVA CONTACTOR ELECTRIC PASSENGER VEHICLE

John M. Bozek, Henry B. Tryon, and Ralph J. Slavik
National Aeronautics and Space Administration
Lewis Research Center
Cleveland, Ohio 44135

November 1977



Prepared for
DEPARTMENT OF ENERGY
Division of Transportation Energy Conservation
Under Interagency Agreement EC-77-A-31-1011

NOTICE

This report was prepared to document work sponsored by the United States Government. Neither the United States nor its agent, the United States Energy Research and Development Administration, nor any Federal employees, nor any of their contractors, subcontractors or their employees, makes any warranty, express or implied, or assumes any legal liability or responsibility for the accuracy, completeness, or usefulness of any information, apparatus, product or process disclosed, or represents that its use would not infringe privately owned rights.

1 Report No NASA TM-73762	2 Government Accession No	3 Recipient's Catalog No	
4 Title and Subtitle BASELINE TESTS OF THE EVA CONTACTOR ELECTRIC PASSENGER VEHICLE	5 Report Date November 1977	6 Performing Organization Code	
	7 Author(s) John M. Bozek, Henry B Tryon, and Ralph J. Slavik	8 Performing Organization Report No E-9481	
9 Performing Organization Name and Address National Aeronautics and Space Administration Lewis Research Center Cleveland, Ohio 44135	10 Work Unit No	11 Contract or Grant No	
	12 Sponsoring Agency Name and Address Department of Energy Division of Transportation Energy Conservation Washington, D.C. 20545	13 Type of Report and Period Covered Technical Memorandum	14 Sponsoring Agency Code Report No. CONS/1011-7
	15 Supplementary Notes Prepared under Interagency Agreement EC-77-A-31-1011.		
16 Abstract The EVA Contactor four-door sedan is an electric passenger vehicle manufactured by Electric Vehicle Associates, Valley View, Ohio It was tested at the Dynamic Science Test Track in Phoenix, Arizona, between January 31 and March 16, 1977. The tests are part of an Energy Research and Development Administration (ERDA) project to characterize the state-of-the-art of electric vehicles. The EVA Contactor performance test results are presented in this report. The EVA Contactor is a four-passenger Renault 12 that has been converted to an electric vehicle. It is powered by 16 series-connected 6-volt electric vehicle batteries through a four-step contactor controller actuated by a foot accelerator pedal. The controller changes the voltage applied to the separately excited DC motor. The braking system is a vacuum-assisted hydraulic braking system. Regenerative braking was also provided			
17 Key Words (Suggested by Author(s)) Electric vehicle; Car; Test and evaluation; Battery	18 Distribution Statement Unclassified - unlimited STAR Category 85 DOE Category UC -96		
19 Security Classif (of this report) Unclassified	20 Security Classif (of this page) Unclassified	21 No of Pages 55	22 Price* A04

The Electric and Hybrid Vehicle Program was conducted under the guidance of the then Energy Research and Development Administration (ERDA), now part of the Department of Energy.

BASELINE TESTS OF THE EVA CONTACTOR

ELECTRIC PASSENGER VEHICLE

John M. Bozek, Henry B. Tryon, and Ralph J. Slavik
Lewis Research Center

SUMMARY

The EVA Contactor, a four-door sedan, is an electric passenger vehicle manufactured by Electric Vehicle Associates, Valley View, Ohio. It was tested at the Dynamic Science Test Track in Phoenix, Arizona, between January 31 and March 16, 1977. The tests are part of an Energy Research and Development Administration (ERDA) project to characterize the state-of-the-art of electric vehicles. The EVA Contactor performance test results are presented in this report.

The EVA Contactor is a four-passenger Renault 12 that has been converted to an electric vehicle. It is powered by 16 series-connected 6-volt electric vehicle batteries through a four-step contactor controller actuated by a foot accelerator pedal. The controller changes the voltage applied to the separately excited DC motor. The braking system is a vacuum-assisted hydraulic braking system. Regenerative braking was also provided.

All tests were run at the gross vehicle weight of 1700 kilograms (3750 lbm). The results of the tests are as follows:

Test speed or driving schedule		Type of test							
		Range		Road power		Road energy		Indicated energy consumption	
		km	mile	kW	hp	MJ/km	kWh/mile	MJ/km	kWh/mile
40	25	76.3	47.5	3.5	4.7	0.30	0.13	1.5	0.65
56	35	57.3	35.6	6.3	8.4	40	18	1.6	70
72	45	42.0	26.1	^a 10.4	^a 13.9	^a 52	^a 1.16	2.1	92
	^b	53.3	33.1	-----	-----	-----	-----	1.8	82
	^c	52.1	32.4	-----	-----	-----	-----	1.7	77
	^b	45.0	28.0	-----	-----	-----	-----	1.7	.75
	^c	35.2	23.2	-----	-----	-----	-----	2.3	1.07

^aExtrapolated data.

^bWith regenerative braking.

^cWithout regenerative braking.

The EVA Contactor was able to accelerate from 0 to 32 kilometers per hour (0 to 20 mph) in 8.8 seconds and from 0 to 48 kilometers per hour (0 to 30 mph) in 15.4 seconds.

ORIGINAL PAGE IS
OF POOR QUALITY

Measurements were made to assess the performance of the vehicle components. The performance was as follows:

Charger efficiency over a complete87 to 92
charge cycle, percent	
Battery efficiency with 37-percent60
overcharge, percent	
Controller efficiency, percent	>95
Motor efficiency at constant speed, percent.82 to 85

INTRODUCTION

The vehicle tests and the data presented in this report are in support of Public Law 94-413 enacted by Congress on September 17, 1976. The law requires the Energy Research and Development Administration (ERDA) to develop data characterizing the state-of-the-art of electric and hybrid vehicles. The data so developed are to serve as a baseline (1) to compare improvements in electric and hybrid vehicle technologies, (2) to assist in establishing performance standards for electric and hybrid vehicles, and (3) to help guide future research and development activities.

The National Aeronautics and Space Administration (NASA), under the direction of the Electric and Hybrid Research, Development, and Demonstration Office of the Division of Transportation Energy Conservation of ERDA, has conducted track tests of electric vehicles to measure their performance characteristics and vehicle component efficiencies. The tests were conducted according to ERDA Electric and Hybrid Vehicle Test and Evaluation Procedure, described in appendix E of reference 1. This procedure is based on the Society of Automotive Engineers (SAE) J227a procedure (ref. 2). Seventeen electric vehicles have been tested under this phase of the program, 12 by NASA, 4 by MERADCOM, and 1 by the Canadian government.

The assistance and cooperation of Warren Harhay, the president of Electric Vehicle Associates, is greatly appreciated. The Energy Research and Development Administration provided funding support and guidance during this project.

U.S. customary units were used in the collection and reduction of data. The units were converted to the International System of Units for presentation in this report. U.S. customary units are presented in parentheses. The parameters, symbols, units, and unit abbreviations used in this report are listed here for the convenience of the reader.

Parameter	Symbol	SI units		U.S. customary units	
		Unit	Abbrevia- tion	Unit	Abbrevia- tion
Acceleration	a	meter per second squared	m/s ²	mile per hour per second	mph/s
Area	---	square meter	m ²	square foot; square inch	ft ² , in ²
Energy	---	megajoule	MJ	kilowatt hour	kWh
Energy consumption	E	megajoule per kilometer	MJ/km	kilowatt hour per mile	kWh/mile
Energy economy	---	megajoule per kilometer	MJ/km	kilowatt hour per mile	kWh/mile
Force	P	newton	N	pound force	lbf
Integrated current	---	ampere hour	Ah	ampere hour	Ah
Length	---	meter	m	inch; foot; mile	in., ft, ---
Mass, weight	W	kilogram	kg	pound mass	lbm
Power	P	kilowatt	kW	horsepower	hp
Pressure	---	kilopascal	kPa	pound per square inch	psi
Range	---	kilometer	km	mile	---
Specific energy	---	megajoule per kilogram	MJ/kg	watt hour per pound	Wh/lbm
Specific power	---	kilowatt per kilogram	kW/kg	kilowatt per pound	kW/lbm
Speed	V	kilometer per hour	km/h	mile per hour	mph
Volume	---	cubic meter	m ³	cubic inch, cubic foot	in ³ , ft ³

OBJECTIVES

The objectives of the tests were to measure maximum speed, range at constant speed, range over stop-and-go driving schedules, maximum acceleration, gradeability, road energy consumption, road power, indicated energy consumption, battery charger efficiency, battery characteristics, controller efficiency, and motor efficiency for the EVA Contactor electric passenger vehicle.

TEST VEHICLE DESCRIPTION

The EVA Contactor is a converted Renault 12 propelled by a direct-current (DC) series-wound electric motor and powered by 16 series-connected 6-volt electric vehicle batteries. The EVA Contactor is an experimental, one-of-a-kind vehicle built to evaluate the capabilities of a sophisticated contactor control system. It is not intended for production or general use by the public. A four-step contactor speed controller, actuated by a foot throttle, changes the voltage applied to the separately excited DC motor through battery switching. Logic elements in the speed controller also provide field weakening or strengthening by varying the voltage applied to the field. Variable voltage provides better vehicle speed control and enhances its regenerative braking capability. The vehicle is shown in figure 1 and described in detail in appendix A.

The 110/240-volt, alternating-current (AC) single-phase battery charger on board the vehicle charges both the electric vehicle battery and the accessory battery. The vehicle manufacturer specified 6 to 12 hours to completely recharge a fully discharged electric vehicle battery, but for the track tests a longer period was used to assure complete recharging. Regenerative braking was provided on this vehicle. The controller and front battery pack are shown in figure 2.

INSTRUMENTATION

The EVA Contactor was instrumented to measure the vehicle speed and range; the current and voltage of one of the four battery subpacks; the motor current, voltage, and speed; the temperatures of the motor frame and battery case; and the battery current and voltage during charge. Most of these data were telemetered to a central instrumentation facility, where they were recorded on magnetic tape. The telemetry system is described in appendix B.

A schematic diagram of the electric power circuit with the instrumentation sensors is shown in figure 3. A Nucleus Corporation Model NC-7 precision speedometer (fifth wheel) was used to measure vehicle velocity and distance traveled. Auxiliary equipment used with the fifth wheel included a Model ERP-X1 electronic pulser for distance measurement, a Model NC-PTE pulse totalizer, a Model ESS/E expanded-scale speedometer, and a programmable digital attenuator. The fifth wheel was calibrated before each test by rotating it on a constant-speed, fifth-wheel calibrator drum mounted on the shaft of a synchronous AC motor. The accuracy of the distance and velocity readings was within ± 0.5 percent of the readings. Distance and velocity were recorded on magnetic tape through the telemetry system.

The integrated battery current was measured for one of the four battery subpacks with a current shunt and an on-board current integrator. It was recorded manually after each test. The current integrator is a Curtis Model SHR-C3 current integrator and was calibrated periodically to within ± 1 percent of reading.

Motor current, motor voltage, and motor speed were measured to determine motor performance. A 500-ampere current shunt was used to measure motor current. Motor shaft speed was measured by means of a light-reflecting photoelectric sensor that detects the passage of a strip of reflecting paint on the flywheel. These measurements were telemetered and recorded on magnetic tape. Temperatures on the motor and on both the front and rear battery packs were

monitored and continuously recorded on magnetic tape during the tests. In addition, battery electrolyte temperatures and specific gravities were measured manually before and after the tests.

Power for the fifth wheel and current integrator was provided from an automotive 12-volt starting, lighting, and ignition (SLI) battery. A Tripp Lite 500-watt DC/AC inverter provided the AC power. The power for the telemetry system was obtained from a battery power pack described in appendix B.

All instruments were calibrated periodically. The integrators and strip-chart recorders were calibrated with a Hewlett-Packard Model 6920 B meter calibrator, which has an accuracy of 0.2 percent of reading and a usable range of between 0.01 and 1000 volts.

The current and voltage into the battery and the energy into the battery charger were measured while the battery was being recharged after each test. The current and voltage to the battery were recorded on a Honeywell 195 Electronik two-channel strip-chart recorder. The current was measured with a 500-ampere current shunt in all the tests. The energy delivered to the charger was measured with a General Electric 1-50A single-phase residential kilowatt-hour meter.

TEST PROCEDURES

The tests described in this report were performed at the Dynamic Science Test Track, a two-lane, 3.22-kilometer (2-mile) asphalt track located in Phoenix, Arizona. A complete description of the track is given in appendix C. When the vehicle was delivered to the test track, the pretest checks described in appendix D were conducted. The first test was a formal shakedown to familiarize the driver with the operating characteristics of the vehicle, to check out all instrumentation systems, and to determine the vehicle's maximum speed. All tests were run in accordance with ERDA Electric and Hybrid Vehicle Test And Evaluation Procedure ERDA-EHV-TEP (appendix E of ref. 1) at the gross weight of the vehicle, 1700 kilograms (3750 lbm). Braking and traction tests were not conducted. Failure of the vehicle and the battery charger necessitated an early termination of the test program.

Handling tests were omitted at the request of ERDA.

ORIGINAL PAGE 45
OF POOR QUALITY

Range Tests at Constant Speed

The vehicle speed for the highest constant-speed range test was determined during checkout tests of the vehicle. It was specified as 95 percent of the minimum speed the vehicle could maintain on the test track when it was traveling at full power. This speed was 72 kilometers per hour (45 mph) for the EVA Contactor.

Range tests at constant speeds were run at 40, 56, and 72 kilometers per hour (25, 35, and 45 mph). The speed was held constant within ± 1.6 kilometers per hour (1 mph), and the test was terminated when the vehicle could no longer maintain 95 percent of the test speed.

Range Tests under Driving Schedules

Schedule B and C cycle tests shown in figure 4 were run on this vehicle, with and without the regenerative system operative. A complete description of the cycle tests is given in appendix E of reference 1. A special instrument, called a cycle timer, was developed at the Lewis Research Center to assist in accurately running these tests. Details of the cycle timer are given in appendix D. The cycle tests were terminated when the cruise speed could not be attained in the time required under maximum acceleration.

Acceleration and Coast-Down Tests

The maximum acceleration of the vehicle was measured on a level road with the battery fully charged and 40 and 80 percent discharged. Four runs, two in each direction, were conducted at each of the three states of charge. Depth of discharge was determined from the number of ampere-hours removed from the batteries. Acceleration runs were made on the southern straight section of the track, and coast-downs on the northern straight section (appendix B, fig. B-1). Coast-down data were taken after the acceleration test with the transmission in neutral and with fully charged batteries in order to start the coast-down run from the maximum attainable vehicle speed.

Charger Efficiency Tests

Charger efficiency was measured. A residential kilowatt-hour meter was used to measure input power to the charger by counting rotations of the disk and applying the meter manufacturer's calibration factor. The charger output power was determined by multiplying the average value of current by the average value of voltage. Residential kilowatt-hour meters are calibrated for sinusoidal waves

only. The error in measuring input power depends on the wave shape and may be as high as 5 percent. The method of determining output power is correct only when either the voltage or the current is a constant during each charging pulse. The battery voltage does change during each charging pulse, which introduces a small error. The current shunts used to measure current are inaccurate for pulsing current. The error depends on frequency and wave shape and may exceed 10 percent.

TEST RESULTS

During the maximum acceleration tests performed on February 11, 1977, the vehicle failed after the first seven range tests had been completed. The repairs and modifications to increase reliability that were made by the vehicle manufacturer after this failure substantially reduced the performance of the vehicle. These modifications included redesign and upgrading of the motor field control circuit and replacement of the DC traction motor. Four additional range tests and a maximum acceleration test were performed after these repairs. After these additional tests had been completed, further degradation in vehicle performance was noted during two later range tests. It appears that the substantial overcharge and resultant heating of the batteries caused this degradation. At this point, March 31, 1977, the test program was terminated.

The results of the 13 range tests that were performed are shown in table I. Three categories of vehicle performance are noted in the table: Mark I, and original vehicle; Mark II, the vehicle after circuit redesign and motor replacement; and Mark III, the Mark II vehicle after battery degradation.

Data are presented in table I for the three separate vehicle performance categories. There is a substantial degradation in both constant-speed range and schedule C range between the Mark I and Mark III vehicle results. Changes in the time at which the transmission gears shifted were also noted from the first (Mark I) to the later (Mark II) maximum acceleration tests. The Mark II vehicle remained in first and second gear longer than did the Mark I vehicle.

The test results presented in the body of this report are limited to those tests performed with the Mark I vehicle, except where noted. In general, these tests were performed between January 31 and March 11, 1977. Appendix E contains a brief discussion of test results from the Mark II and Mark III vehicles.

Range

A total of seven range tests were performed on the Mark I vehicle: one each at constant speeds of 40, 56, and 72 kilometers per hour (25, 35, and 45 mph); two schedule B tests, one with and one without the regenerative braking operative; and two schedule C tests, one with and one without the regenerative braking operative. The range of the Mark I varied from 76.4 kilometers (47.5 miles) at a constant speed of 40 kilometers per hour (25 mph) to 42 kilometers (26.1 miles) at 72 kilometers per hour (45 mph). The effect of regenerative braking was minimal during the schedule B tests, increasing the range from 52.1 kilometers (32.4 miles) to 53.3 kilometers (33.1 miles). Regenerative braking increased the range during the schedule C tests by 21 percent, from 37.3 kilometers (23.2 miles) to 45 kilometers (28 miles).

The maximum speed of the vehicle was measured during the checkout tests. It is defined as the average speed that could be maintained on the track under full power. The measured maximum speed was 80 kilometers per hour (50 mph) for this vehicle. This differs from the maximum speed used in the range tests.

Maximum Acceleration

The maximum acceleration of the vehicle was determined with the battery fully charged. Because of the failure of vehicle components during the maximum acceleration tests, the 40- and 80-percent-discharge conditions were not run. Vehicle speed as a function of time is shown in figure 5 and table II. The vehicle accelerated to 32 kilometers per hour (20 mph) in 8.8 seconds and to 48 kilometers per hour (30 mph) in 15.4 seconds. The average acceleration \bar{a}_n was calculated for the time period t_{n-1} to t_n , where the vehicle speed increased from V_{n-1} to V_n , from the equation

$$\bar{a}_n = \frac{V_n - V_{n-1}}{t_n - t_{n-1}}$$

and the average speed of the vehicle \bar{V} from the equation

$$\bar{V} = \frac{V_n + V_{n-1}}{2}$$

Acceleration as a function of vehicle speed is shown in figure 6 and table II. The initial acceleration was 1.1 meters per second squared (2.5 mph/sec) at 16 kilometers per hour (10 mph) and 0.55 meter per second squared (1.2 mph/sec) at 48 kilometers per hour (30 mph).

Gradeability

The maximum specific grade, in percent, that a vehicle can climb at an average vehicle speed \bar{V} was determined from maximum acceleration tests by using the equations

$$G = 100 \tan (\sin^{-1} 0.1026 \bar{a}_n) \quad \text{for } \bar{V} \text{ in km/h}$$

in SI units

or

$$G = 100 \tan (\sin^{-1} 0.0455 \bar{a}_n) \quad \text{for } \bar{V} \text{ in mph}$$

in U.S. customary units

where \bar{a}_n is average acceleration in meters per second squared (mph/sec). The maximum grade the EVA Contactor can negotiate as a function of speed is shown in figure 7 and table II. The vehicle can negotiate a 12.2-percent grade at a low speed of 16 kilometers per hour (10 mph); the grade decreases to 5.2 percent at 48 kilometers per hour (30 mph).

Road Energy Consumption

Road energy is a measure of the energy consumed per unit distance in overcoming the vehicle's aerodynamic and rolling resistance plus the energy consumed in the differential drive shaft and the portion of the transmission rotating when in neutral. It was obtained during coast-down tests, when the differential was being driven by the wheels, and thus may be different from the energy consumed when the differential is being driven by the motor. Figure 8 shows vehicle speed as a function of time during coast down from a maximum speed of 72 kilometers per hour (44.5 mph). The data are also presented in table III.

Road energy consumption E_n was calculated from the following equations:

$$E_n = 2.78 \times 10^{-4} W \frac{V_{n-1} - V_n}{t_n - t_{n-1}}, \text{ MJ/km}$$

or

$$E_n = 9.07 \times 10^{-5} W \frac{V_{n-1} - V_n}{t_n - t_{n-1}}, \text{ kWh/mile}$$

where

W vehicle mass, kg (lbm)

V vehicle speed, km/h (mph)

t time, s

The results of the road energy calculations are shown in figure 9 and table IV. The road energy varied from 0.221 megajoule per kilometer (0.0986 kWh/mile) at 12.9 kilometers per hour (8 mph) to 0.488 megajoule per kilometer (0.218 kWh/mile) at 68.1 kilometers per hour (42.3 mph).

Road Power Requirements

Road power is a measure of the vehicle's propulsion power that is required to overcome aerodynamic and rolling resistance plus the power losses from the differential, the drive shaft, and a portion of the transmission. The road power P_n required to propel a vehicle at various speeds was also determined from the coast-down test data. The following equations were used:

$$P_n = 3.86 \times 10^{-5} W \frac{V_{n-1}^2 - V_n^2}{t_n - t_{n-1}}, \text{ kW}$$

or

$$P_n = 6.08 \times 10^{-5} W \frac{V_{n-1}^2 - V_n^2}{t_n - t_{n-1}}, \text{ hp}$$

ORIGINAL PAGE IS
OF POOR QUALITY

The results of road power calculations are shown in figure 10 and table IV. The road power decreased from 9.22 kilowatts (12.3 hp) at 68.1 kilometers per hour (42.3 mph) to 0.79 kilowatt (1.05 hp) at 12.9 kilometers per hour (8.0 mph).

Indicated Energy Consumption

The vehicle's indicated energy consumption is defined as the energy required to recharge the battery after a test, divided by the vehicle range achieved during the test, where the energy is the input to the battery charger.

The energy input to the battery charger was measured with a residential kilowatt-hour meter after each range test. Some overcharge of the battery was usually required in order to assure that all battery cells were fully charged and that the pack was equalized. The reported energy usage may be higher than would be experienced with normal vehicle field operation. The indicated energy consumption and the calculated values of overcharge for seven range tests are shown in table V. The overcharge, in six of the seven tests, was substantially higher than the 10-percent overcharge desired for low energy consumption. The energy consumption was corrected to a value corresponding to a 10-percent overcharge by assuming a direct linear relationship between the energy out of the charger and the capacity restored to the battery. The results of this correction are shown in the last two columns of table V.

COMPONENT PERFORMANCE AND EFFICIENCY

Battery Charger

The EVA Contactor electric-vehicle-battery charger is an SCR charger that charges in the following sequence: (1) constant current initially, (2) constant voltage with current taper during the intermediate phase, and (3) low constant current until the charging is terminated by the operator. The input power required is 110 to 220 volts AC single phase. A 110-volt AC tap is available to operate a 12-volt charger that supplies DC power to power relays and to charge two 12-volt SLI batteries. These batteries power the controller and the vehicle accessories. The power relays put the electric vehicle battery system in a 96-volt configuration for charging.

The efficiency of the charger was calculated by using readings from a residential energy meter (kWh meter), which measured power input, and from the multiplication of average DC current and voltage on the DC side of charger. During

the efficiency test, the 12-volt charger was powered by means of a separate 110-volt AC line. The power efficiency of the electric vehicle battery portion of the charger was determined to be 92 percent during the first few hours of charging and 85 percent during the last few hours. The 12-volt charger required 6.8 percent of the input charger power during the first few hours of charging and 16 percent during the last few hours. The overall power efficiency of the charger, which includes the power to the 12-volt charger and the electric vehicle batteries, is 92 percent during the first few hours of charging and 87 percent during the last few hours.

The mean power efficiency, which is assumed to be equivalent to the energy efficiency of the charger, is 88.5 percent for the electric vehicle portion and 89.5 percent for the full charger, including energy to power the 12-volt charger. Possible errors in the measurements are discussed in the section INSTRUMENTATION.

The total amount of energy that is delivered to the battery depends not only on the charger efficiency, but also on the mechanism used to terminate the charge. The EVA Contactor charging system will continue to charge the electric vehicle battery and the SLI batteries at reduced currents until the charge is terminated manually. Consequently, the amount of energy that is delivered to the electric vehicle battery is largely determined by the judgment of the operator. During the track tests the battery was purposely overcharged to assure that all the cells were fully charged.

Battery

Manufacturer's data. - The battery supplied with the EVA Contactor was made up of ESB Incorporated Exide or Willard EV-106 electric vehicle batteries. The EV-106 is a 6-volt, three-cell battery rated to deliver 75 amperes for 106 minutes to a voltage cutoff of 1.75 volts per cell at a temperature of 25° C (77° F). Battery characteristics as supplied by the battery manufacturer are shown in table VI.

The battery manufacturer's discharge data are presented in figures 11 and 12. Discharge current and voltage as a function of the length of time the battery is able to deliver this current is shown in figure 11. The battery can deliver 10 amperes for 20 hours (200 Ah) or 250 amperes for 0.37 hour (92.5 Ah). At a discharge current of 10 amperes, the mean cell voltage was 2.0 volts; at a discharge current of 250 amperes, the mean cell voltage dropped to 1.5 volts during the discharge period. The battery's rated capacity

is about 15 percent lower than the capacity shown in figure 11.

Specific power as a function of the specific energy available from a three-cell battery is shown in figure 12. At a low specific power of 2 watts per kilogram the available energy was 0.15 megajoule per kilogram (41.7 Wh/kg). At a higher specific power of 40 watts per kilogram the available energy decreased to 0.052 megajoule per kilogram (14.6 Wh/kg). At the manufacturer's rated discharge rate of 75 amperes, which is equivalent to 14 W/kg, the available specific energy was 0.096 megajoule per kilogram (26.7 Wh/kg).

Battery acceptance. - Prior to the track tests the battery supplied by the vehicle manufacturer was checked for terminal integrity as specified in appendix E of reference 1.

The 300-ampere battery terminal integrity test was run with a resistor load bank. Two tests were performed. The first test produced high terminal temperatures. After the battery terminals were cleaned, a second test produced acceptable terminal temperatures. The battery voltage quickly dropped to 79.5 volts and 77.0 volts for the first and second tests, respectively, when it was discharged at a current of 300 amperes, and remained close to these levels throughout the test (fig. 13). At the end of the test, the terminal temperature as measured by temperature-sensitive tape was less than 82° C (180° F). As this was less than 60 degrees Celsius above ambient temperature, the battery was within specifications.

The battery capacity check specified in appendix E of reference 1 was not run. Instead track test results were used to evaluate the battery. During the first two constant-speed tests the battery delivered 155 ampere-hours at the 1.9-hour rate and 131 ampere-hours at the 1.0-hour rate, respectively. As both test results were within the criterion established for accepting the battery (i.e., 80 percent of the rated capacity, which in this case is 106 Ah at the 1.77-h rate), the battery was acceptable.

Battery performance at constant vehicle speed. - During the constant-speed road tests the current and voltage were continually monitored in one of the four battery subpacks (fig. 3). Each subpack contains four 6-volt batteries, with a nominal subpack voltage of 24 volts. The EVA Contactor vehicle speed controller is designed to remove equal amounts of energy from the four battery subpacks. Therefore, it was assumed that the time-averaged powers and

currents for each battery subpack were equal. Total power, and current for the full battery pack were calculated by multiplying the measured values by four.

The average current and the average power delivered by the full battery pack (all four battery subpacks) are shown in figures 14 and 15 and table VII for the constant-speed range tests. All tests, including those run after the vehicle modifications, are shown. The average battery power was 6.5 to 7.2 kilowatts during the 40-kilometer-per-hour (25-mph) range test and 15.3 to 16.0 kilowatts during the 72-kilometer-per-hour (45-mph) range test. The average battery currents were 74 to 82 amperes and 177 to 182 amperes, respectively, for these tests.

Battery performance at maximum acceleration. - Battery performance during a maximum acceleration test is shown in figure 16 and table VIII. The transmission gear (first, second, and third) that the vehicle was in is also shown in figure 16. The battery current, voltage, and power displayed are for one of the four 24-volt battery subpacks.

General battery performance. - Battery data are shown in table IX for 10 vehicle tests. The electrolyte specific gravities ranged from 1.290 to 1.300 for the fully charged battery and from 1.110 to 1.197 for the fully discharged battery. The ampere-hour overcharge varied from 9 percent to 50 percent.

The battery temperature had a tendency to increase from ambient at the start of a test to about 10 degrees Celsius above ambient at the end of a test.

Charging and battery efficiency. - One battery charging phase was fully analyzed to determine battery efficiency. This charge followed the 40-kilometer-per-hour (25-mph) constant-speed test on January 31, 1977.

The battery charger output voltage, current, and power are presented in figures 17 and 18 as a function of time.

Total energy input to the battery during charging was 22.4 kilowatt-hours; the energy removed during the 40-kilometer-per-hour (25-mph) range test was 13.4 kilowatt-hours (7.2 kW times 1.89-h test time). The battery energy efficiency is therefore 60 percent. The ampere-hour overcharge was 37 percent for this test (table IX). A more desirable overcharge would be 10 percent. Correcting to a 10 percent overcharge caused the battery energy efficiency to increase to about 75 percent.

Controller

The speed controller in the EVA Contactor is basically a contactor controller. Armature voltage is varied in discrete steps of 24, 48, 72, and 96 volts through appropriate series and paralleling of the four 24-volt battery subpacks. The effects of an unbalanced battery pack in the 72-volt step are minimized by alternating the battery subpacks that are being heavily discharged. In addition to battery switching to control speed, the speed controller contains logic components that control motor field excitation. These logic components weaken or strengthen the motor field depending on the current level in the motor armature or the amount of regenerative braking desired.

The eight possible configurations of the contactor speed controller and the resultant motor armature and field voltages are shown in table X. Also shown are the mechanisms that actuate the contactor speed controller. The maximum heat dissipation in the contacts is 120 watts, and 250 watts is required from the two SLI batteries to operate the speed controller. Considering only the 120 watts being dissipated in the contacts, the power efficiency of the controller is 98 percent. When the 250-watt loss provided by the SLI batteries is included, the power efficiency of the controller drops to 95 percent.

Motor

The motor used in the EVA Contactor is a separately excited DC motor. The motor was built to EVA specifications. Data on the machine are limited to bench test data with the motor operating in a shunt configuration at 72 volts. At full load the power efficiency was 82 percent. At twice full load, the efficiency increased to 85 percent. Locked motor current was 1722 amperes at 365 newton-meters (269 lb-ft) of torque. These data are for the motor used in the Mark I vehicle. The Mark II vehicle motor had a redesigned field and thus the data may not apply.

VEHICLE RELIABILITY

The EVA Contactor's operating time before the track tests was insufficient to shake down the vehicle. As a result many failures occurred during the early testing. This required replacement of the original components with similar units of higher capacity. One vehicle failure required redesign and upgrading of the motor field circuit and replacement of the original motor with an upgraded version. Eventually, the testing of the vehicle had to be terminated before all scheduled tests were completed because of possible battery degradation and lack of time.

The first major failure occurred before any actual testing. The field circuit contained components that were overloaded. The circuit was replaced with a higher capacity circuit and testing was begun on January 28, 1977. An attempt at maximum acceleration testing (2/11/77), which demands maximum performance of all components, resulted in a failure of the vehicle. At this point the vehicle manufacturer redesigned the logic in the controller and replaced the motor with the upgraded version. Four range tests and a maximum acceleration test were then performed. It was noted during this period (3/16/77 to 3/21/77) that the performance of the vehicle had degraded. In addition, during this period, numerous charger failures delayed tests and resulted in substantial battery overcharge and heating. The remaining two range tests (3/30/77 to 3/31/77) exhibited substantial degradation in vehicle performance.

APPENDIX A

VEHICLE SUMMARY DATA SHEET

- 1.0 Vehicle manufacturer Electric Vehicle Associates
Valley View, Ohio
- 2.0 Vehicle EVA Contactor (Renault 12 conversion)
- 3.0 Price and availability on request
- 4.0 Vehicle weight and load
- | | | |
|-----|--------------------------------|----------------------------|
| 4.1 | Curb weight, kg (lbm) | <u>1430 (3150)</u> |
| 4.2 | Gross vehicle weight, kg (lbm) | <u>1700 (3750)</u> |
| 4.3 | Cargo weight, kg (lbm) | <u>limited trunk space</u> |
| 4.4 | Number of passengers | <u>4 places</u> |
| 4.5 | Payload, kg (lbm) | <u>limited</u> |
- 5.0 Vehicle size
- | | | |
|-----|---|---------------------------------------|
| 5.1 | Wheelbase, m (in.) | <u>2.44 (96.0)</u> |
| 5.2 | Length, m (in.) | <u>4.42 (174.0)</u> |
| 5.3 | Width, m (in.) | <u>1.64 (64.5)</u> |
| 5.4 | Height, m (in.) | <u></u> |
| 5.5 | Head room, m (in.) | <u>0.95 (37.5)</u> |
| 5.6 | Leg room, m (in.) | <u>0.72 (28.5)</u> |
| 5.7 | Frontal area, m ² (ft ²) | <u></u> |
| 5.8 | Road clearance, m (in.) | <u></u> |
| 5.9 | Number of seats | <u>2 bucket, front; 1 bench, rear</u> |
- 6.0 Auxiliaries and options
- | | | |
|-----|-------------------------------------|--|
| 6.1 | Lights (number, type, and function) | <u>4 head; 2 tail; 1 backup;</u>
<u>4 side; 2 brake; hazard flasher; dome</u> |
|-----|-------------------------------------|--|

ORIGINAL PAGE IS
OF POOR QUALITY

6.2 Windshield wipers 2, on front windshield

6.3 Windshield washers yes

6.4 Defroster from heater

6.5 Heater gasoline

6.6 Radio yes

6.7 Fuel gage no

6.8 Amperemeter yes

6.9 Tachometer no

6.10 Speedometer yes

6.11 Odometer yes

6.12 Right- or left-hand drive left

6.13 Transmission 3-speed automatic

6.14 Regenerative braking yes

6.15 Mirrors rearview (inside and outside)

6.16 Power steering no

6.17 Power brakes yes

6.18 Other _____

7.0 Battery

7.1 Propulsion battery

7.1.1 Type and manufacturer lead-acid golf car EV-106;
ESB Incorporated

7.1.2 Number of modules 16

7.1.3 Number of cells 48

7.1.4 Operating voltage, V 24, 48, 72, 96 (switchable)

7.1.5 Capacity, Ah 132.5 (106 min at 75 A)

7.1.6 Size of each module, m (in.) height, 0.248 (9.75);
width, 0.178 (7.0); length, 0.260 (10.25)

7.1.7 Weight, kg (lbm) 472 (1040)

7.1.8 History (age, number of cycles, etc.) new, less than
10 cycles

7.2 Auxiliary battery

7.2.1 Type and manufacturer lead acid (2)

7.2.2 Number of cells 6 per battery

- 7.2.3 Operating voltage, V 12
- 7.2.4 Capacity, Ah 95
- 7.2.5 Size, m (in.) height, 0.22 (9.0); width, 0.11 (4.5);
length, 0.50 (19.5)
- 7.2.6 Weight, kg (lbm) 16.3 (36) per battery

8.0 Controller

- 8.1 Type and manufacturer contactor; Electric Vehicle Associates
- 8.2 Voltage rating, V 24, 48, 72, and 96
- 8.3 Current rating, A 200
- 8.4 Size, m (in.) height, 0.3 (12); width, 0.15 (6);
length, 0.45 (18)
- 8.5 Weight, kg (lbm) 17.2 (38)

9.0 Propulsion motor

- 9.1 Type and manufacturer separately excited DC; Electric
Vehicle Associates
- 9.2 Insulation class F
- 9.3 Voltage rating, V 120
- 9.4 Current rating, A 200 (2-h rating)
- 9.5 Horsepower (rated), kW (hp) _____
- 9.6 Size, m (in) diameter, 0.2 (8.0); length, 0.48 (19)
- 9.7 Weight, kg (lbm) 68 (150)
- 9.8 Speed (rated), rpm 3650 (4300 max.)

10.0 Battery charger

- 10.1 Type and manufacturer SCR; EVA Battery Marshall
- 10.2 On- or off-board type on board
- 10.3 Input voltage required, V 208/240
- 10.4 Peak current demand, A 30
- 10.5 Recharge time, h 6 - 8

ORIGINAL PAGE IS
OF POOR QUALITY

10.6 Size, m (in.) 0.15 (6.0); 0.18 (7.0); 0.30 (12.0)

10.7 Weight, kg (lbm) 13.3 (25.0)

10.8 Automatic turnoff feature optional

11.0 Body

11.1 Manufacturer and type Renault 12, 4 door

11.2 Materials steel

11.3 Number of doors and type 4

11.4 Number of windows and type 6; glass

11.5 Number of seats and type 2 bucket, front; 1 bench, rear

11.6 Cargo space volume, m³ (ft³)

11.7 Cargo space dimensions, m (ft)

12.0 Chassis

12.1 Frame

12.1.1 Type and manufacturer unitized with subframe;
Groupe Renault

12.1.2 Materials steel

12.1.3 Modifications battery-retaining members added

12.2 Springs and shocks

12.2.1 Type and manufacturer coil springs, front and rear;
Renault shocks, front; TRW shocks, rear

12.2.2 Modifications

12.3 Axles

12.3.1 Manufacturer Renault

12.3.2 Front independent

12.3.3 Rear live axle

12.4 Transmission

12.4.1 Type and manufacturer 3-speed automatic; Renault

- 12 4.2 Gear ratios 2.44; 1.44; 1.00
-
- 12 4.3 Driveline ratio 3.65 (final drive)
-
- 12.5 Steering
- 12.5.1 Type and manufacturer rack and pinion
-
- 12.5.2 Turning ratio 20
-
- 12.5.3 Turning diameter, m (ft) 10 (32.8)
-
- 12.6 Brakes
- 12.6.1 Front power-assist disk, hydraulic
-
- 12 6 2 Rear power-assist drum, hydraulic
-
- 12 6 3 Parking mechanical, on rear wheels
-
- 12.6.4 Regenerative yes
-
- 12 7 Tires
- 12.7.1 Manufacturer and type Michelin radial
-
- 12.7.2 Size 155SR13ZX
-
- 12.7.3 Pressure, kPa (psi):
- Front 220 (32)
-
- Rear 220 (32)
-
- 12.7.4 Rolling radius, m (in.) 0.28 (11.02)
-
- 12.7.5 Wheel weight, kg (lbm):
- Without drum
-
- With drum
-
- 12.7.6 Wheel track, m (in.):
- Front
-
- Rear
-
- 13.0 Performance
- 13.1 Manufacturer-specified maximum speed (wide-open throttle), km/h (mph)
88 (55)
-
- 13.2 Manufacturer-recommended maximum cruise speed (wide-open throttle),
km/h (mph) 60 (38)
-
- 13 3 Tested at cruise speed, km/h (mph) 40.2 (25); 56.3 (35);
72.4 (45)
-

ORIGINAL PAGE IS
OF POOR QUALITY

APPENDIX B

DATA ACQUISITION

Data acquired from the test vehicle are conditioned onboard the vehicle and transmitted to the Data Acquisition Center where they are demodulated and recorded on magnetic tape (fig. B-1).

The following paragraphs provide a detailed description of system components. Instrumentation calibration procedures and test procedures relative to the data acquisition system are also described.

Signal Conditioning Equipment

The signal conditioning equipment has a modular or building-block configuration. The basic building block is the remote signal conditioning module (RSCM), which consists of all the necessary functions required to take the basic transducer information and store it on magnetic tape. Each RSCM handles 14 data channels.

Internally, the RSCM consists of all the necessary components required to signal condition, modulate onto Inter-Range Instrumentation Group (IRIG) constant-bandwidth frequency-modulated (FM) channels, and transmit a transducer output signal to a remote tape recorder. Figure B-2 is the system diagram defining this RSCM.

The signal conditioning amplifiers in the front end of the RSCM provide suitable gain and balance to normalize all transducer outputs into common formats and to drive the voltage-controlled oscillators (VCO's). Each amplifier has a built-in, isolated bridge power supply regulated at 5.0 volts DC that negates loading effects from other transducers and changes in output due to supply battery variations. This power supply is used either alone, divided down by 0.1-percent metal film resistors, or in series with other supplies to provide a highly accurate and stable voltage insertion calibration of the entire system, channel by channel.

The VCO's convert analog voltages to a frequency-modulated unbalanced signal. The center frequencies of the VCO's are set at values defined by IRIG 106-71 for constant-bandwidth channels (Table B-1). The +2.5-volt outputs from the amplifier provide +100-percent deviation of the VCO's. Using a mix of A and B channels provides an optimum combination of data frequency response, resolution, percentage of deviation, and channel density in

each multiplex.

The system is designed to provide 1000-hertz data channel bandwidth on all A channels and 2000-hertz channel bandwidth on all B channels. The 14 VCO outputs are mixed onto a common bus which provides the output signal to be recorded. An external 28-volt battery is used to power the RSCM.

Each RSCM weighs under 9 kilograms (20 lbm) and covers approximately 390 square centimeters (60 in²) of floor space. All input and output connections and final adjustments are accessible from the top of the module.

System Accuracy

Table B-2 represents the system errors for the data acquisition system. The values are taken from the component specifications. As there are several information conversions through the system, there was an attempt to translate the specifications into a "common error domain." Each device in the system has a set of parameters that represent its performance in a particular region of the multidimensional space (e.g., an accelerometer converts an acceleration into a voltage (actually an energy conversion) with some nonlinearity of information conversion). There is a conversion from analog voltage to frequency with a corresponding nonlinearity in the VCO. The tape recorder has to handle the information mechanically with high accuracy because a change in tape speed represents a change in frequency which, in turn, represents a change in the original analog voltage.

Tape Recorders

The tape recorder has 14 IRIG-compatible channels, with the recording channels individually controlled so that multiple recording passes may be made on the same tape. Capstan speed accuracy of 0.01 percent is obtained by use of a tape speed compensator system while flutter is held to 0.22 percent. Time base and dynamic skew are 0.5 and 25 microseconds, respectively.

APPENDIX C

DESCRIPTION OF VEHICLE TEST TRACK

The test track used to conduct the tests described in this report is located in Phoenix, Arizona. The track is owned and operated by Dynamic Science, a subsidiary of Talley Industries.

The test track is a paved, continuous two-lane, 3.2-kilometer- (2-mile-) long oval with an adjacent 40 000-square-meter (10-acre) skid pad. The inner lane of the track is not banked and was used for all cycle tests and all constant-speed tests of 56 kilometers per hour (35 mph) or under. The outer lane has zero lateral acceleration at 80 kilometers per hour (50 mph) and was used for tests over 56 kilometers per hour (35 mph). An elevation survey of the track is shown in figure C-1. Average grade is 0.66 percent on the northern straight section and 0.76 percent on the southern straight section. The surface of the track and skid pad is asphaltic concrete with a dry locked-wheel skid number of 82 and a wet locked-wheel skid number of 71.

Wet and dry braking-in-turn tests were conducted on the skid pad. Wet recovery tests were conducted on the test track after driving through the wet-brake water trough located near the northern straight section of the track. Both 20- and 30-percent grades are available for parking brake tests.

APPENDIX D

VEHICLE PREPARATION AND TEST PROCEDURE

Vehicle Preparation

When a vehicle was received at the test track, a number of checks were made to assure that it was ready for performance tests. These checks were recorded on a vehicle preparation check sheet, such as the one shown in figure D-1. The vehicle was examined for physical damage when it was removed from the transport truck and before it was accepted from the shipper. Before the vehicle was operated, a complete visual check was made of the entire vehicle including wiring, batteries, motor, and controller. The vehicle was weighed and compared with the manufacturer's specified curb weight. The gross vehicle weight (GVW) was determined from the vehicle sticker GVW. If the manufacturer did not recommend a GVW, it was determined by adding 68 kilograms (150 lbm) per passenger plus any payload weight to the vehicle curb weight.

The wheel alignment was checked, compared, and corrected to the manufacturer's recommended alignment values. The battery was charged and specific gravities taken to determine if the batteries were equalized. If not, an equalizing charge was applied to the batteries. The integrity of the internal interconnections and the battery terminals was checked by drawing either 300 amperes or the vehicle manufacturer's maximum allowed current load from the battery through a load bank for 5 minutes. If the temperature of the battery terminals or interconnections rose more than 60 degrees Celsius above ambient, the test was terminated and the terminal was cleaned or the battery replaced. The batteries were then recharged and a battery capacity check was made. The battery was discharged in accordance with the battery manufacturer's recommendations. To pass this test, the capacity must be within 20 percent of the manufacturer's published capacity at the published rate.

The vehicle manufacturer was contacted for his recommendations concerning the maximum speed of the vehicle, tire pressures, and procedures for driving the vehicle. The vehicle was photographed head-on with a 270-millimeter telephoto lens from a distance of about 30.5 meters (100 ft) in order to determine the frontal area.

Test Procedure

Each day, before a test, a test checklist was used. Two samples of these checklists are shown in figure D-2.

The first item under driver instructions on the test checklist is to complete the pretest checklist (fig. D-3).

Data taken before, during, and after each test were entered on the vehicle data sheet (fig. D-4). These data include

- (1) Average specific gravity of the battery
- (2) Tire pressures
- (3) Fifth-wheel tire pressure
- (4) Test weight of the vehicle
- (5) Weather information
- (6) Battery temperatures
- (7) Time the test was started
- (8) Time the test was stopped
- (9) Ampere-hours out of the battery
- (10) Fifth-wheel distance count
- (11) Odometer readings before and after the tests

The battery charge data taken during the charge cycle were also recorded on this data sheet. These data include the average specific gravity of the battery after the test, the kilowatt-hours and ampere-hours put into the battery during the charge, and the total time of the charge.

To prepare for a test, the specific gravities were first measured for each cell and recorded. The tire pressures were measured and the vehicle was weighed. The weight was brought up to the GVW by adding sandbags. The instrumentation was connected, and power from the instrumentation battery was applied. All instruments were turned on and warmed up. The vehicle was towed to the starting point on the track. If the data were being telemetered, precalibrations were applied to both the magnetic tape and the oscillograph. The fifth-wheel distance counter and ampere-hour integrator counter were reset to zero, and thermocouple reference junctions were turned on. The test was started and was carried out in accordance with the test checklist. When the test was terminated, the vehicle was brought to a stop and the post-test checks were made in accordance with the post-test

checklist (fig. D-5). The driver recorded on the vehicle data sheet the time, the odometer reading, the ampere hour integrator reading, and the fifth-wheel distance reading. The post-calibration steps were then applied to the magnetic tape and the oscillograph. At the end of the test, weather data were recorded on the vehicle data sheet. All instrumentation power was turned off, the instrumentation battery was disconnected, and the fifth wheel was raised. The vehicle was then towed back to the garage, the post-test specific gravities were measured for all cells and the vehicle was placed on charge.

After the test, the engineer conducting the test completed a test summary sheet (fig. D-6). This data sheet provides a brief summary of the pertinent information received from the test. Another data sheet, the engineer's data sheet (fig. D-7), was also filled out. This data sheet summarizes the engineer's evaluation of the test and provides a record of problems, malfunctions, changes to instrumentation, etc., that occurred during the test.

Weather data. - Wind velocity and direction and ambient temperature were measured at the beginning and at the end of each test and every hour during the test. The wind anemometer was located about 1.8 meters (6 ft) from the ground near the southern straight section of the track. The ambient temperature readings were taken at the instrumentation trailer near the west curve of the track. During most of the test period the winds were variable and gusty.

Determination of maximum speed. - The maximum speed of the vehicle was determined in the following manner. The vehicle was fully charged and loaded to gross vehicle weight. After one warmup lap, the vehicle was driven at wide-open throttle for three laps around the track. The minimum speed for each lap was recorded and the average was calculated. This average was called the vehicle maximum speed. This speed takes into account track variability and maximum vehicle loading. This quantity was then reduced by 5 percent and called the recommended maximum cruise test speed.

Cycle timer. - The cycle timer (fig. D-8) was designed to assist the vehicle driver in accurately driving SAE schedules B, C, and D. The required test profile is permanently stored on a programmable read-only memory (PROM), which is the heart of the instrument. This profile is continuously reproduced on one needle of a dual-movement analog meter shown in the figure. The second needle is connected to the output of the fifth wheel and the driver

"matches needles" to accurately drive the required schedule.

One second before each speed transition (e.g., acceleration to cruise or cruise to coast), an audio signal sounds to forewarn the driver of a change. A longer duration audio signal sounds after the idle period to emphasize the start of a new cycle. The total number of test cycles driven is stored in a counter and can be displayed at any time with a pushbutton (to conserve power).

ORIGINAL PAGE IS
OF POOR QUALITY

APPENDIX E

PERFORMANCE OF EVA CONTACTOR

MARK II AND MARK III

During the attempt to run a maximum acceleration profile on the original vehicle, a fuse blew and various components in the field controller failed. These components were replaced with upgraded versions, the field control was redesigned, and new field windings were installed in the motor before testing was resumed. The vehicle, which we now designated Mark II, underwent four range tests. The results of these tests are shown in table I. Maximum acceleration tests were also performed at various depths of battery discharge.

There was no apparent difference in the performance of the Mark I and Mark II vehicles during the constant-speed tests. Yet the distance traveled during the schedule C test with regenerative braking was substantially longer with the Mark I vehicle than with the Mark II vehicle, 45 kilometers (28 miles) and 30 kilometers (18.6 miles), respectively. Comparing the maximum acceleration test data for the Mark I and Mark II vehicles revealed another change. Though both vehicles were able to accelerate to 48 kilometers per hour (30 mph) in about the same time, 14.1 seconds for the Mark I and 15.5 seconds for the Mark II, the shift points were drastically different. The Mark I vehicle shifted at 9.5 and 16 seconds; the Mark II vehicle shifted at 6.3 and 11.3 seconds.

The data obtained from the maximum acceleration tests on the Mark II vehicle are presented in figures E-1 to E-3 and tables E-1 to E-3.

REFERENCES

1. Sargent, Noel B.; Maslowski, Edward A.; Soltis, Richard F.; and Schuh, Richard M.: Baseline Tests of the C. H. Waterman DAF Electric Passenger Vehicle. NASA TM-73757, 1977.
2. Society of Automotive Engineers, Inc.: Electric Vehicle Test Procedure - SAE J227a. Feb. 1976.

TABLE I - SUMMARY OF TEST RESULTS FOR EVA CONDUCTOR

(a) SI units

Vehicle	Test date	Test condition (constant speed, km/h; or driving schedule)	Wind velocity, km/h	Temper- ature, °C	Range, km	Cycle life, number of cycles	Current out of batteries, Ah	Current into batteries, Ah	Energy into charger, MJ	Indicated energy consumption, MJ/km	Remarks
Mark I	1/31/77	40	5	17	76.4	—	155	213	111	1.5	
	2/1/77	56	14	14	57.3	—	131	156	89.6	1.6	
	2/2/77	72	10	16	42.0	—	111	165	86.5	2.1	
	2/3/77	B ^a	16	18	53.3	152	167	182	97.2	1.8	
	2/4/77	B ^b	11	18	52.1	163	166	203	89.6	1.7	
	2/5/77	C ^a	5 - 24	18	45.1	95	154	181	75.2	1.7	
	2/6/77	C ^b	5	8	37.3	66	132	174	89.3	2.39	Charger failed
Mark II	3/18/77	C ^a	11	18	29.9	53	99	104	—	—	Redesigned field control, new motor; heavy over- charge, hot batteries
	3/19/77	56	3 - 8	20	55.5	—	124	126	56.2	1.0	Charger malfunction
	3/20/77	72	8	19	37.0	—	82	138	54.0	1.5	
	3/21/77	40	0 - 16	22	80.9	—	148	—	—	—	Charger malfunction
Mark III	3/30/77	C ^b	6 - 13	13	23.0	39	82	99	67.0	2.9	Charger malfunction
	3/31/77	72	0 - 5	13	27.0	—	71	72	—	—	Charger malfunction

(b) U.S. customary units

Vehicle	Test date	Test condition (constant speed, mph; or driving schedule)	Wind velocity, mph	Temper- ature, °F	Range, miles	Cycle life, number of cycles	Current out of batteries, Ah	Current into batteries, Ah	Energy into charger, kWh	Indicated energy consumption, kWh/mile	Remarks
Mark I	1/31/77	25	3	63	47.5	—	155	213	30.9	0.65	
	2/1/77	35	9	58	35.6	—	131	156	24.9	.70	
	2/2/77	45	6	60	26.1	—	111	165	24.0	.92	
	2/3/77	B ^a	10	64	33.1	152	167	182	27.0	.82	
	2/4/77	B ^b	7	64	32.4	163	166	203	24.9	.77	
	2/5/77	C ^a	3 - 15	65	28.0	95	154	181	20.9	.75	
	2/6/77	C ^b	3	47	23.2	66	132	174	23.8	1.07	Charger failed
Mark II	3/18/77	C ^a	7	65	18.6	53	99	104	—	—	Redesigned field control, new motor, heavy over- charge, hot batteries
	3/19/77	35	2 - 5	68	34.5	—	124	126	15.6	0.45	Charger malfunction
	3/20/77	45	5	67	23	—	92	138	15.0	.65	
	3/21/77	25	0 - 10	72	50.3	—	148	—	—	—	Charger malfunction
Mark III	3/30/77	C ^b	4 - 8	55	14.3	39	82	99	18.6	1.30	Charger malfunction
	3/31/77	45	0 - 5	55	16.8	—	71	72	—	—	Charger malfunction

^aWith regenerative braking

^bWithout regenerative braking

TABLE II. - MAXIMUM ACCELERATION AND GRADEABILITY OF EVA

CONTACTOR AT FULL BATTERY CHARGE

Vehicle speed		Time to reach designated vehicle speed, s	Vehicle acceleration		Gradeability, percent
km/h	mph		m/sec ²	mph/sec	
1.5	0.9	0.7	0	0	0
3.5	2.2	1.6	.94	2.10	9.7
5.5	3.4	2.0	1.29	2.89	13.4
7.5	4.6	2.4	1.26	2.81	13.0
9.5	5.9	2.9	1.17	2.62	12.1
11.5	7.1	3.4	1.14	2.55	11.8
13.5	8.4	3.9	1.06	2.37	10.9
15.5	9.6	4.4	1.10	2.46	11.3
17.5	10.9	4.9	1.23	2.76	12.8
19.5	12.1	5.3	1.24	2.78	12.8
21.5	13.3	5.8	1.14	2.55	11.8
23.5	14.6	6.3	1.03	2.31	10.6
25.5	15.8	6.9	.98	2.20	10.1
27.5	17.1	7.5	.96	2.15	9.9
29.5	18.3	8.0	.93	2.09	9.6
31.5	19.6	8.6	.87	1.95	9.0
33.5	20.8	9.3	.81	1.82	8.4
35.5	22.0	10.0	.79	1.77	8.2
37.5	23.3	10.7	.78	1.73	8.0
39.5	24.5	11.4	.75	1.68	7.7
41.5	25.8	12.2	.68	1.52	7.0
43.5	27.0	13.1	.61	1.36	6.2
45.5	28.3	14.0	.58	1.29	5.9
47.5	29.5	15.0	.55	1.24	5.7
49.5	30.8	16.1	.49	1.09	5.0
51.5	32.0	17.3	.41	.91	4.2
53.5	33.2	18.8	.37	.82	3.7
55.5	34.5	20.4	.31	.70	3.2
57.5	35.7	22.4	.26	.59	2.7
59.5	37.0	24.6	.23	.52	2.4
61.5	38.2	27.2	.24	.55	2.5
63.5	39.5	29.3	.28	.62	2.8
65.5	40.7	31.2	.27	.60	2.8
67.5	41.9	33.4	.24	.54	2.5
69.5	43.2	35.9	.21	.47	2.2
71.5	44.4	38.7	.18	.40	1.8
73.5	45.7	42.2	.15	.33	1.5
75.5	46.9	46.2	.11	.55	1.1
77.5	48.2	53.0	.07	.16	.7
79.5	49.4	61.6	.06	.14	.6

TABLE III. - DECELERATION

TIMES FOR EVA CONTACTOR

Vehicle speed		Time, s
km/h	mph	
72.0	44.5	0
64.4	40.0	7.0
57.9	36.0	14.0
48.3	30.0	25.9
41.8	26.0	35.2
32.2	20.0	50.9
25.7	16.0	63.2
16.9	10.0	83.4
9.7	6.0	97.2
0	0	123.9

TABLE IV. - ROAD ENERGY CONSUMPTION AND ROAD
POWER REQUIREMENT OF EVA CONTACTOR

Vehicle speed		Road energy consumed		Road power required	
km/h	mph	MJ/km	kWh/mile	kW	hp
68.1	42.3	0.488	0.218	9.22	12.3
61.1	38.0	.434	.194	7.37	9.83
53.1	33.0	.383	.171	5.64	7.52
45.1	28.0	.327	.146	4.09	5.45
37.0	23.0	.291	.130	2.99	3.99
29.0	18.0	.248	.111	2.00	2.67
20.9	13.0	.225	.101	1.31	1.75
12.9	8.0	.221	.99	.79	1.05
4.8	3.0	.171	.76	.23	.31

TABLE V. - ENERGY CONSUMPTION OF EVA CONTACTOR

Test speed or driving schedule		Amount of overcharge, percent	Indicated energy consumption		Corrected energy consumption ^a	
km/h	mph		MJ/km	kWh/mile	MJ/km	kWh/mile
40	25	37	1.45	0.65	1.16	0.52
56	35	19	1.57	.70	1.45	.65
72	45	47	2.06	.92	1.54	.69
B ^b		9	1.83	.82	1.86	.83
B ^c		22	1.72	.77	1.54	.69
C ^b		17	1.68	.75	1.59	.71
C ^c		27	2.39	1.07	2.08	.93

^aEnergy consumption corresponding to 10-percent overcharge.

^bWith regenerative braking.

^cWithout regenerative braking.

ORIGINAL PAGE IS
OF POOR QUALITY

TABLE VI. - EV-106 BATTERY CHARACTERISTICS

Length, m (in.)	0.26 (10.375)
Width, m (in.)	0.18 (7.188)
Height, m (in.)	0.28 (11.219)
Weight, kg (lbm):	
Dry.	21.4 (47.2)
Wet.	29.5 (65.1)
Electrolyte content, liters (qt).	6.2 (6.6)
Life (laboratory), number of cycles	400 - 450
Fully charged specific gravity.	1.280
Number of plates per cell	19

TABLE VII. - BATTERY PERFORMANCE FOR EVA CONTACTOR

Vehicle	Vehicle speed		Battery current, A	Battery power	
	km/h	mph		kW	hp
Mark I	40	25	82	7.2	9.6
	56	35	118	9.9	13.2
Mark II	40	25	74	6.5	8.7
	56	35	128	10.8	14.4
	72	45	177	15.3	20.4
Mark III	72	45	182	16.0	21.3

TABLE VIII. - BATTERY PERFORMANCE DURING MAXIMUM ACCELERATION TEST OF EVA CONTACTOR AT FULL BATTERY CHARGE

Gradeability, percent	Current, A	Voltage, V	Power, kW
0	268.6	21.4	5.7
1.1	293.6	21.1	6.2
1.8	320.6	20.7	6.6
2.5	351.3	20.3	7.1
2.8	379.8	20.0	7.6
2.4	230.1	22.0	5.1
3.2	264.9	21.6	5.7
4.2	307.0	21.0	6.4
5.7	348.8	20.4	7.1
6.2	386.4	19.9	7.7
8.2	285.1	21.4	6.1
9.0	319.8	20.9	6.7
9.9	374.7	20.1	7.5
10.7	413.7	19.5	8.1

TABLE IX. - BATTERY TEST DATA SUMMARY FOR EVA CONTACTOR

Test date	Test speed or driving schedule		Current into battery, Ah	Current out of battery, Ah	Battery overcharge (in Ah), percent	Electrolyte specific gravity		Battery temperature, °C	
	km/h	mph				Before test	After test	Before test	After test
1/31/77	40	25	213	155	37	1.360	1.137	-----	31 - 42
3/21/77	40	25	---	148	--	1.298	1.127	30 - 33	39 - 44
2/1/77	56	35	156	131	19	1.300	1.157	-----	-----
3/19/77	56	35	---	124	--	1.290	1.152	20 - 22	25 - 30
2/2/77	72	45	165	112	47	1.300	1.186	-----	30 - 35
3/20/77	72	45	138	92	50	1.293	1.197	25 - 29	30 - 35
2/3/77	B ^a		182	167	9	1.300	1.110	26 - 30	-----
2/4/77	B ^b		203	166	22	↓	1.110	28 - 32	-----
2/5/77	C ^a		181	154	18	↓	1.119	32 - 36	38
2/6/77	C ^b		---	137	--	↓	1.150	34	36

^aWith regenerative braking.

^bWithout regenerative braking.

TABLE X. - CONTROLLER OPERATION FOR EVA CONTACTOR

Operating mode	Configuration	Armature voltage, v	Field voltage, ^a v	Actuating mechanism
Acceleration and constant-speed operation	1	12	24	Key switch (idle position) Foot pedal ↓
	2	24	24	
	3	48	48	
	4	48	24	
	5	72	48	
	6	96	48	
Regenerative braking operation	7	-24	24	Foot off accelerator Brake applied and transmission downshifted to second gear
	8	-24	36	

^aIf armature current is greater than 200 A, field voltage increases by 12 V. If armature current is less than 150 A, field voltage is as shown.

TABLE B-1. - CONSTANT-BANDWIDTH CHANNELS

IN EACH REMOTE SIGNAL-CONDITIONING

MODULE FOR EVA CONTACTOR

IRIG ^a constant- bandwidth channel	Center frequency, kHz	Deviation, kHz
1A	16	+2
2A	24	↓
3A	32	
4A	40	
5A	48	
6A	56	
7A	64	
8A	72	
9A	80	
11B	96	
13B	112	↓
15B	128	
17B	144	
19B	160	

TABLE B-2. - DIRECT-CURRENT AMPLITUDE ACCURACY

Transducer	Parameter	Accuracy, percent
DC voltage	Tolerance	±0.4
Calibration resistors	Tolerance	±.1
Amplifier	Nonlinearity	±.5
Voltage-controlled oscillator	Nonlinearity	±.25
Recorder	Speed inaccuracy	±.01
Data demodulator	Nonlinearity	±.1

TABLE E-1. - ACCELERATION TIMES FOR EVA CONTACTOR

(MARK II)

Vehicle speed		Amount of discharge, percent		
km/h	mph	0	40	80
		Time to reach designated vehicle speed, s		
0	0	0	0	0
2.0	1.2	.4	.4	.6
4.0	2.5	.7	.7	.9
6.0	3.7	1.0	.9	1.2
8.0	5.0	1.2	1.1	1.4
10.0	6.2	1.5	1.4	1.7
12.0	7.5	1.6	1.7	2.0
14.0	8.7	1.9	1.9	2.3
16.0	9.9	2.1	2.2	2.7
18.0	11.2	2.6	2.6	3.1
20.0	12.4	3.0	3.0	3.6
22.0	13.7	3.4	3.6	4.2
24.0	14.9	3.9	4.2	4.8
26.0	16.2	4.5	4.9	5.7
28.0	17.4	5.2	5.6	6.7
30.0	18.7	5.9	6.4	7.9
32.0	19.9	6.5	7.1	8.8
34.0	21.1	7.2	7.0	9.8
36.0	22.4	8.8	8.7	10.9
38.0	23.6	8.8	9.6	12.0
40.0	24.9	9.6	10.7	13.3
42.0	26.1	10.5	11.8	14.6
44.0	27.4	11.7	13.0	16.2
46.0	28.6	12.8	14.5	18.2
48.0	29.8	14.1	16.3	20.6
50.0	31.1	15.7	18.4	24.0
52.0	32.3	17.2	20.2	27.6
54.0	33.6	18.7	22.0	38.4
56.0	34.8	20.4	23.7	33.4
58.0	36.1	22.0	26.0	36.9
60.0	37.3	23.8	28.4	40.9
62.0	38.5	25.9	31.4	45.1
64.0	39.8	28.2	34.5	----
66.0	41.0	31.0	38.2	----
68.0	42.3	34.2	----	----
70.0	43.5	38.1	----	----
72.0	44.8	42.2	----	----

TABLE E-2. - ACCELERATION CHARACTERISTICS FOR EVA CONTACTOR

(MARK II)

Vehicle speed		Amount of discharge, percent					
km/h	mph	0		40		80	
		Vehicle acceleration					
		m/s ²	mph/s	m/s ²	mph/s	m/s ²	mph/s
0	0	0	0	0	0	0	0
2.0	1.2	1.85	4.14	1.61	3.60	1.26	2.81
4.0	2.5	2.19	4.91	2.24	5.01	1.89	4.22
6.0	3.7	2.22	4.97	2.57	5.75	2.35	5.26
8.0	5.0	2.23	5.00	2.39	5.34	2.23	5.00
10.0	6.2	2.58	5.78	2.09	4.68	1.94	4.33
12.0	7.5	2.56	5.72	2.04	4.56	1.80	4.02
14.0	8.7	2.23	5.00	2.04	4.57	1.68	3.75
16.0	9.9	1.92	4.28	1.72	3.86	1.52	3.39
18.0	11.2	1.38	3.09	1.39	3.10	1.19	2.65
20.0	12.4	1.32	2.96	1.16	2.59	.99	2.21
22.0	13.7	1.13	2.54	.98	2.19	.90	2.02
24.0	14.9	1.08	2.41	.85	1.90	.75	1.67
26.0	16.2	.90	2.00	.77	1.73	.61	1.37
28.0	17.4	.77	1.72	.72	1.60	.53	1.18
30.0	18.7	.84	1.87	.75	1.68	.53	1.20
32.0	19.9	.84	1.88	.77	1.73	.58	1.29
34.0	21.1	.79	1.77	.58	1.53	.53	1.19
36.0	22.4	.73	1.64	.63	1.41	.51	1.14
38.0	23.6	.67	1.49	.57	1.27	.47	1.05
40.0	24.9	.65	1.45	.53	1.18	.43	.95
42.0	26.1	.56	1.24	.49	1.09	.39	.87
44.0	27.4	.48	1.08	.41	.91	.31	.70
46.0	28.6	.46	1.02	.34	.76	.25	.56
48.0	29.8	.38	.85	.29	.64	.20	.44
50.0	31.1	.36	.81	.29	.66	.16	.36
52.0	32.3	.37	.84	.31	.68	.18	.40
54.0	33.6	.35	.79	.31	.70	.19	.43
56.0	34.8	.34	.75	.29	.65	.17	.39
58.0	36.1	.33	.73	.24	.53	.15	.33
60.0	37.3	.29	.65	.21	.47	.14	.30
62.0	38.5	.25	.57	.18	.41	.12	.26
64.0	39.8	.22	.49	.16	.37	----	----
66.0	41.0	.19	.41	.13	.29	----	----
68.0	42.3	.16	.36	----	----	----	----
70.0	43.5	.14	.31	----	----	----	----
72.0	44.8	.11	.24	----	----	----	----

TABLE E-3. - GRADEABILITY OF EVA CONTACTOR

(MARK II)

Vehicle speed		Amount of discharge, percent		
km/h	mph	0	40	80
		Gradeability, percent		
0	0	0	0	0
2.0	1.2	19.3	16.7	13.0
4.0	2.5	23.1	23.6	19.7
6.0	3.7	23.4	27.3	24.9
8.0	5.0	23.5	25.2	23.5
10.0	6.2	27.5	22.0	20.2
12.0	7.5	27.1	21.4	18.7
14.0	8.7	23.5	21.4	17.5
16.0	9.9	20.0	18.0	15.7
18.0	11.2	14.3	14.4	12.3
20.0	12.4	13.7	12.0	10.2
22.0	13.7	11.7	10.1	9.3
24.0	14.9	11.1	8.7	7.7
26.0	16.2	9.2	8.0	6.3
28.0	17.4	7.9	7.4	5.4
30.0	18.7	8.6	7.7	5.5
32.0	19.9	8.7	8.0	5.9
34.0	21.1	8.1	7.0	5.4
36.0	22.4	7.5	6.5	5.2
38.0	23.6	6.8	5.8	4.8
40.0	24.9	6.7	5.4	4.4
42.0	26.1	5.7	5.0	4.0
44.0	27.4	5.0	4.2	3.2
46.0	28.6	4.7	3.5	2.6
48.0	29.8	3.9	2.9	2.0
50.0	31.1	3.7	3.0	1.6
52.0	32.3	3.8	3.1	1.8
54.0	33.6	3.6	3.2	2.0
56.0	34.8	3.5	3.0	1.8
58.0	36.1	3.3	2.4	1.5
60.0	37.3	3.0	2.1	1.4
62.0	38.5	2.6	1.9	1.2
64.0	39.8	2.3	1.7	----
66.0	41.0	1.9	1.3	----
68.0	42.3	1.6	----	----
70.0	43.5	1.4	----	----
72.0	44.8	1.1	----	----

38

ORIGINAL PAGE IS
OF POOR QUALITY

C-77-224A

Figure 1. - EVA Contactor electric passenger vehicle on Dynamic Science Test Track.

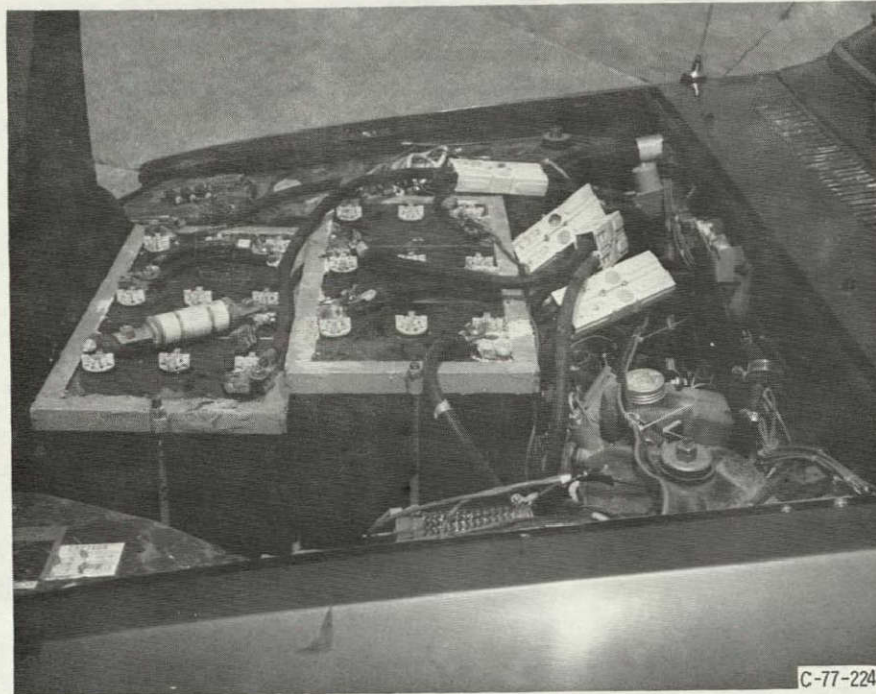

C-77-2242

Figure 2. - View under hood of EVA Contactor showing front battery pack.

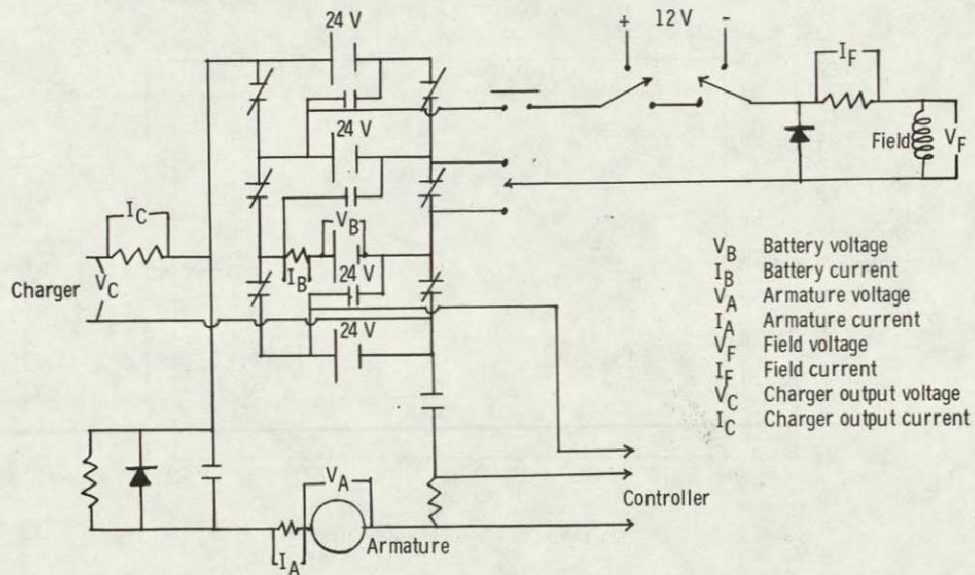
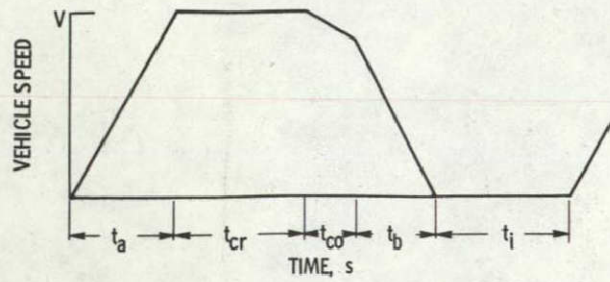

Figure 3. - Schematic diagram of EVA Contactor power circuit and instrumentation.



TEST PARAMETER	SAE SCHEDULES		
	B	C	D
MAX. SPEED, V, mph	20	30	45
ACCEL. TIME, t_a , s	19	18	28
CRUISE TIME, t_{cr}	19	20	50
COAST TIME, t_{co}	4	8	10
BRAKE TIME, t_b	5	9	9
IDLE TIME, t_i	25	25	25

Figure 4. - SAE J227a driving cycle schedules.

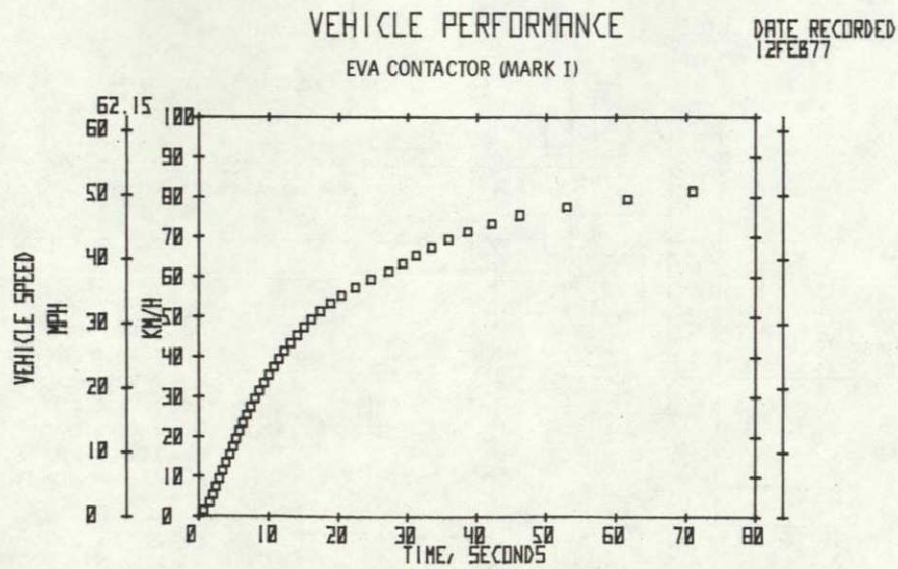

Figure 5. - Vehicle acceleration.

ORIGINAL PAGE IS
OF POOR QUALITY

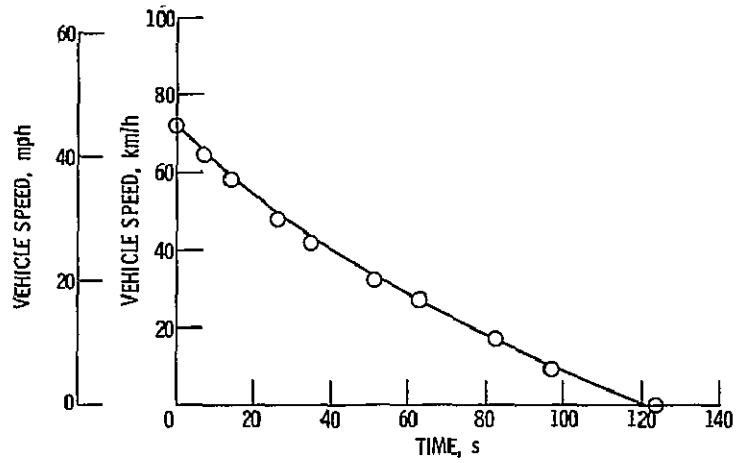

Figure 8. - Deceleration times for EVA Contactor.

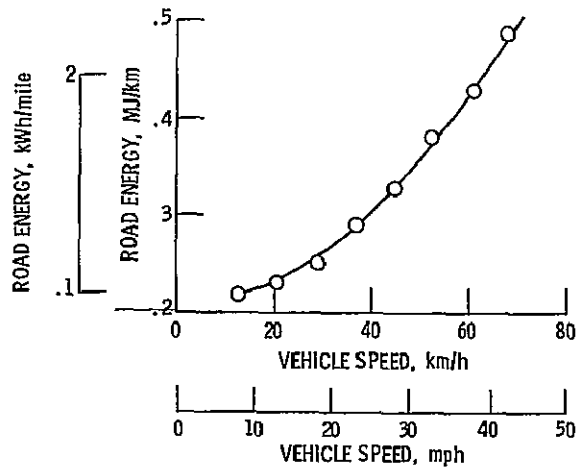

Figure 9. - Road energy as a function of speed for EVA Contactor.

ORIGINAL PAGE IS
OF POOR QUALITY

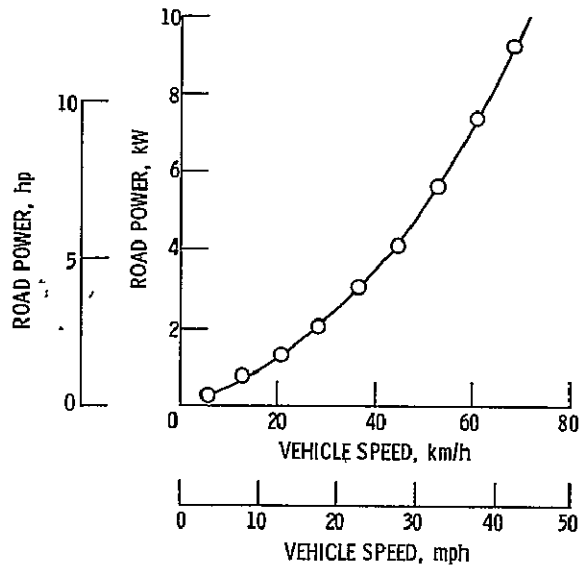

Figure 10 - Road power as a function of speed for EVA Contactor

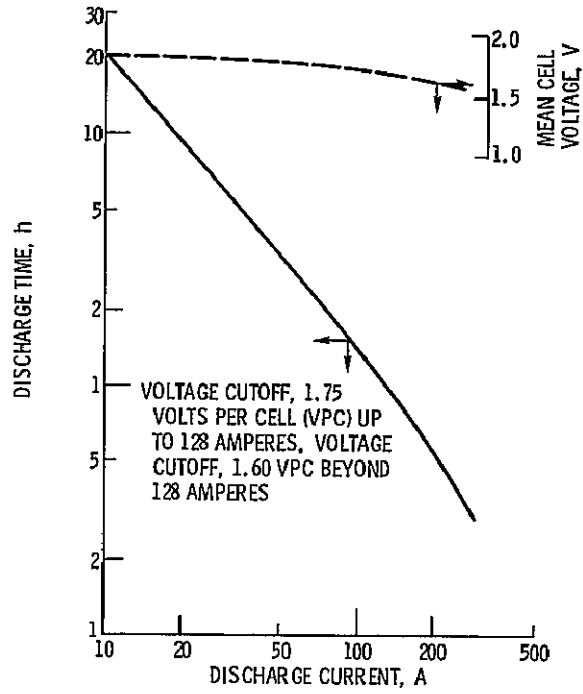

Figure 11, - Battery discharge characteristics for EVA Contactor

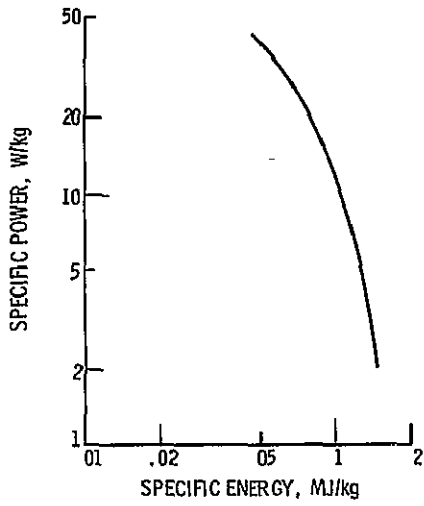

Figure 12 - Battery energy/power relationship for EVA Contactor

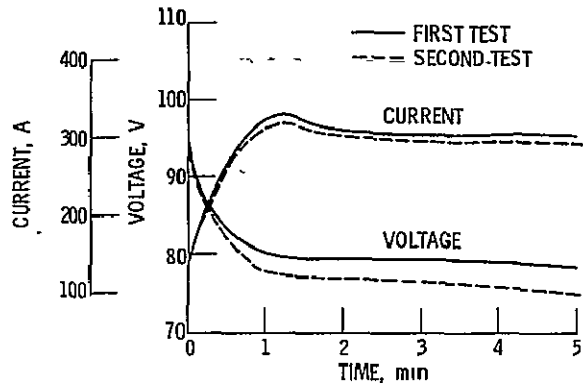

Figure 13 - Battery 300-ampere terminal test for EVA Contactor

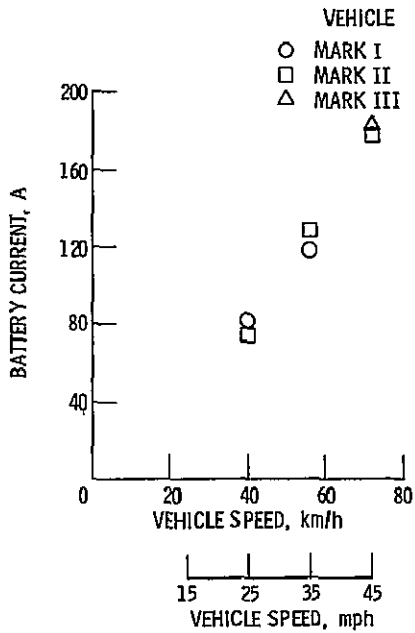

Figure 14. - Battery current at constant speed for EVA Contactor,

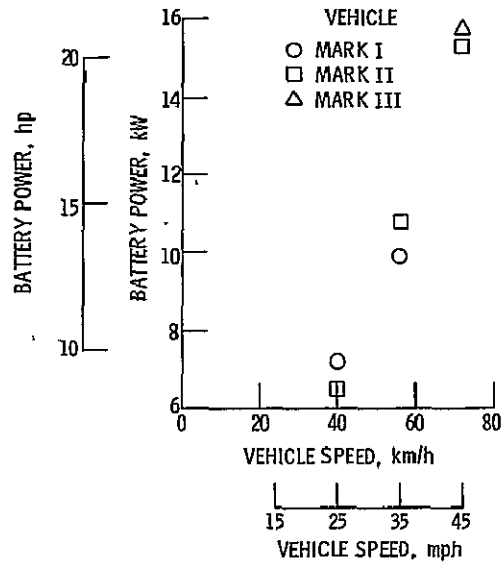

Figure 15. - Battery power at constant speed for EVA Contactor

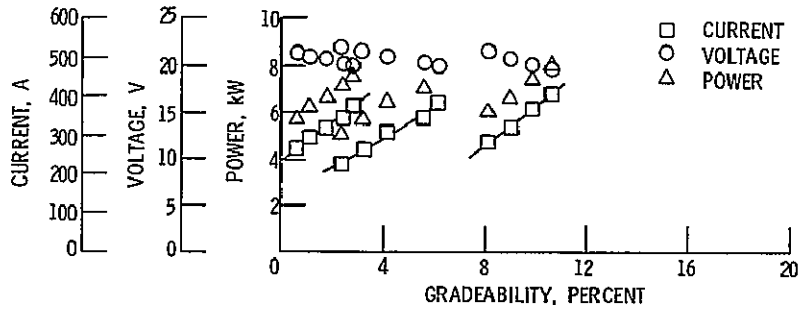

Figure 16 - Battery output during acceleration for EVA Contactor at full battery charge Test date, February 12, 1977

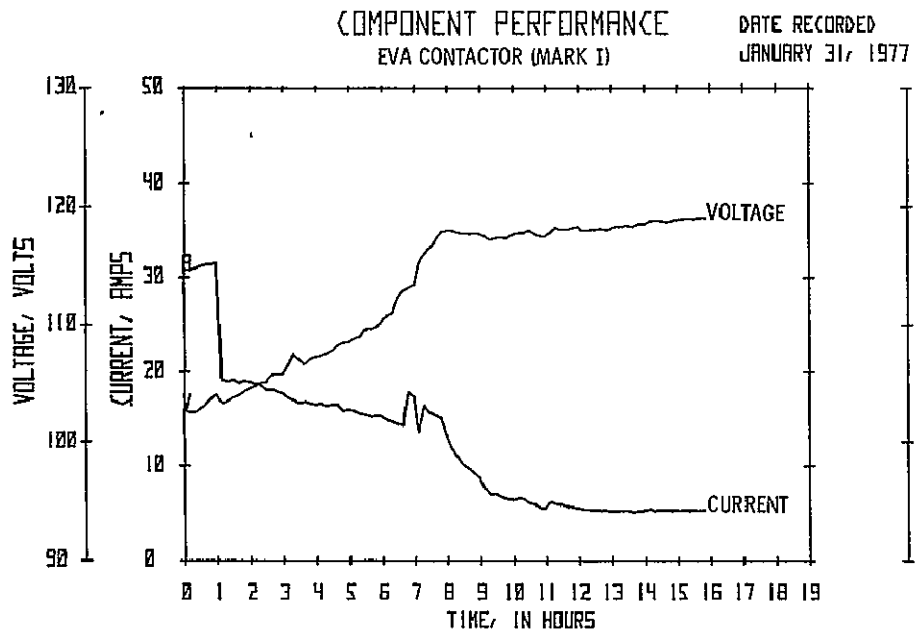

Figure 17. - Battery charger output current and voltage

COMPONENT PERFORMANCE

EVA CONTACTOR

(MARK I)

DATE RECORDED
JANUARY 31, 1977

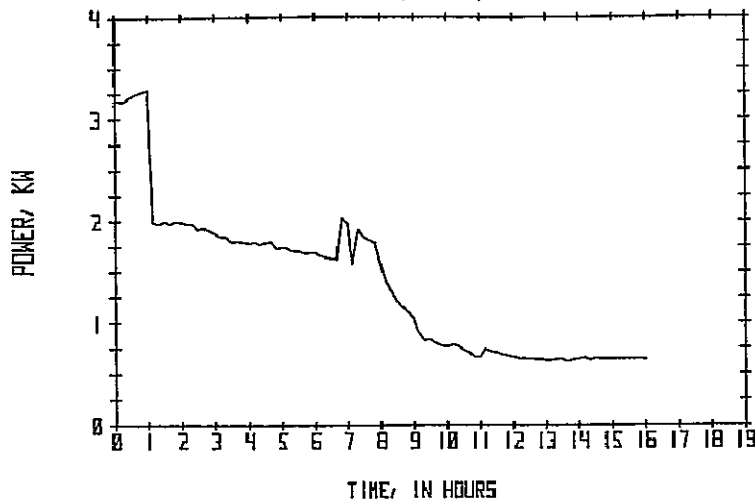

Figure 18 - Battery charger output power

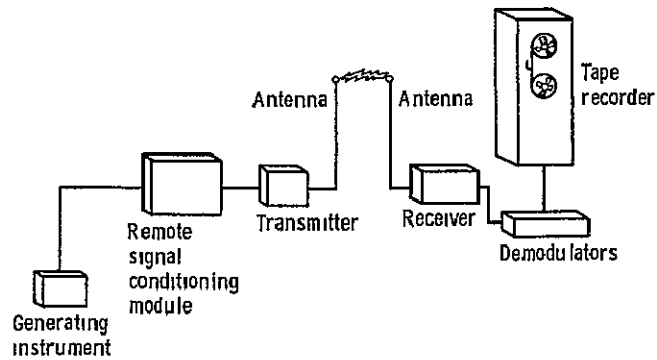

Figure B-1, - Data acquisition system schematic

ORIGINAL PAGE IS
OF POOR QUALITY.

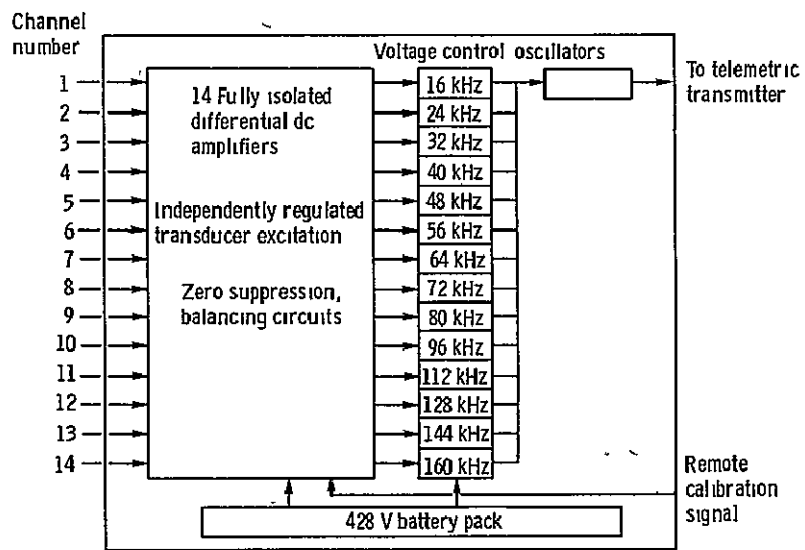

Figure B-2 - Remote signal conditioning module diagram

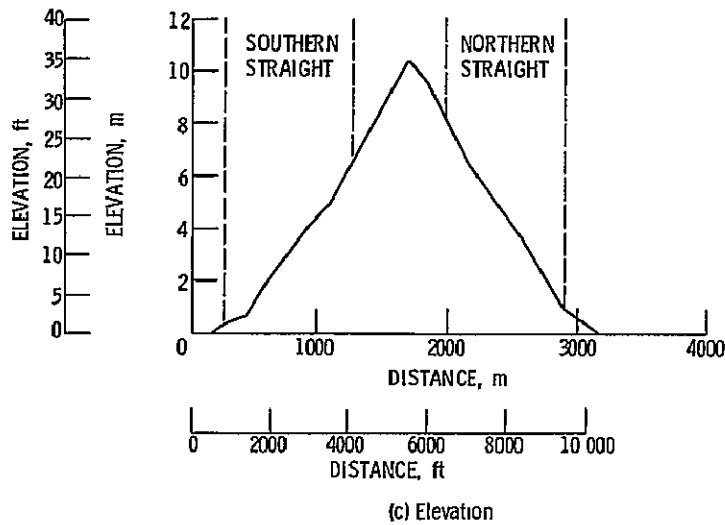
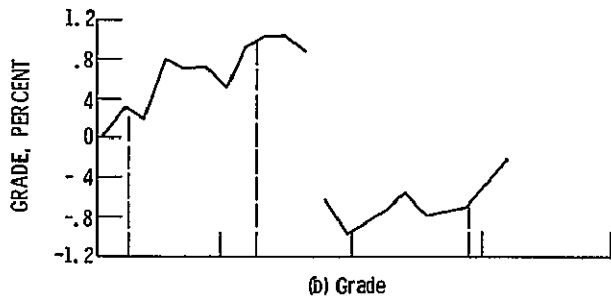
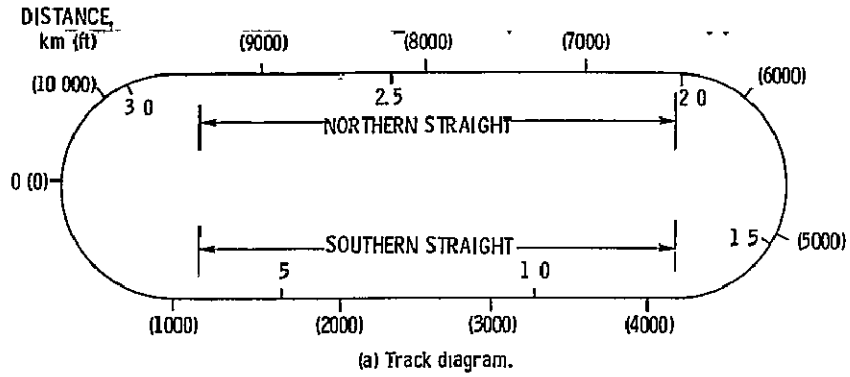

Figure C-1. - Characteristics of Dynamic Science Test Track, Phoenix, Arizona

1	Vehicle _____
2	Date received _____
3	Checked for damage - date _____
4	Wheel alignment - date _____
5	Battery checked and equalized - date _____
6	Curb weight determined, lbm _____ Date _____
7	Gross vehicle weight, lbm _____
8	300-Ampere test - date _____
9	Manufacturers recommendations
	Maximum speed, mph _____
	Tire pressures, psi Front _____, Rear _____
	Driving procedures _____

Figure D-1 - Vehicle preparation check sheet

Vehicle _____, _____ mph range test, _____ gear

Driver Instructions

- 1 Complete pretest checklist
- 2 While on track recheck
Integrator - light on, in "operate" position, zeroed
Speedometer - set on _____ mph center
Distance - on, reset, lighted
Attenuator - on, reset, lighted
- 3 At signal from control center accelerate moderately to _____ mph
- 4 Maintain _____ ±1 mph with minimal accelerator movement
- 5 When vehicle is no longer able to maintain _____ mph, brake moderately to full stop.
- 6 Complete post-test checklist and other documentation.

Recording:

1. Set oscillograph zeros at	<u>Channel</u>	<u>Zero, in</u>
	3	3 0
	4	4 5
	6	5 0
	10	7 5
	12	1 1
	13	1.2
	14	2.0

- 2 Record all channels on magnetic tape Check inputs at beginning of test to verify recording
- 3 Run cals on all channels
- 4 Remove all channels from oscillograph except 3 and 4
- 5 Start recording 15 s before start of test at oscillograph speed of 0.1 in/s and tape speed of _____ in/s.
- 6 After 15 min into test connect channels 6, 10, 12, 13, and 14 to oscillograph and record a burst at 100 in/s while vehicle is in chopper mode
- 7 Remove channels 6, 10, 12, 13, and 14 from oscillograph and continue test at 0.1 in/s with channels 3 and 4 only.
- 8 Document all ambient conditions at beginning, once every hour, and at the end of the test Items recorded shall include temperature, wind speed and direction, significant wind gusts, and corrected barometric pressure

(a) Constant-speed test

Figure D-2, - Test checklists.

ORIGINAL PAGE IS
OF POOR QUALITY

Vehicle _____, _____ cycle test, _____ gear

Driver Instructions.

1. Complete pretest checklist.
2. While on track recheck
 - Integrator - light on, in "operate" position, zeroed
 - Speedometer - set on _____ mph center
 - Distance - on, reset, lighted
 - Attenuator - on, reset, selector on 100
 - Cycle timer - verify scheduled timing with stop watch
3. At signal from control center, perform cycle test using cycle timer as basis for determining length of each phase of performance cycle. Use programmed stop watch as backup device. Cycle consists of
 - Accelerate to _____ mph in _____ s
 - Cruise at _____ mph for _____ s
 - Coast for _____ s
 - Brake to complete stop in _____ s
 - Hold in stop position for _____ s

Repeat entire cycle until vehicle is unable to meet acceleration time. Moderately brake to a complete stop.
4. Complete post-test checklist and other documentation.

Recording.

1. Record all channels on magnetic tape at _____ in/s. Check all channels to verify input at beginning of test
2. Record speed and distance on oscillograph at _____ in/s.
3. Start recording data 15 s before beginning test.
4. Document ambient conditions at beginning, once every hour, and at the end of the test. Items recorded shall include temperature, wind speed and direction, significant wind gusts, and corrected barometric pressure.

φ) Driving cycle test

Figure D-2. - Concluded.

1. Record specific gravity readings after removing vehicle from charge, and disconnect charger instrumentation. Fill in charge data portion of data sheet from previous test. Add water to batteries as necessary, recording amount added. Check and record 5th wheel tire pressure and vehicle tire pressure.
2. Connect. (Connect alligator clips to instrumentation battery last)
 - (a) Inverter to instrument battery
 - (b) Integrator input lead
 - (c) Integrator power to inverter
 - (d) Starred (*) 5th wheel jumper cable
 - (e) Cycle timer power and speed signal input cables. Check times
 - (f) Spin up and calibrate 5th wheel
3. Record test weight - includes driver and ballast with 5th wheel raised.
4. Turn on:
 - (a) Inverter, motor speed sensor, thermocouple reference junctions, integrator, and digital voltmeter. Set integrator on "Operate"
 - (b) Fifth wheel readout and switching interface units (2). (Select distance for expanded scale range)
5. Tow vehicle onto track with 5th wheel raised
 - Precalibrations
 - Tape data system
 - Oscillograph
 - Reset
 - 5th wheel distance
 - Ampere-hour meter
 - Thermocouple readout switches on "Record"
 - Turn on thermocouple reference junctions
 - Lower 5th wheel. Set hub loading
6. Be sure data sheet is properly filled out to this point. Check watch time with control tower.
7. Proceed with test

Figure D-3. - Pretest checklist.

Vehicle _____	Battery system _____
Test _____	Date _____
Track data.	
Driver _____	Navigator _____
Average pretest specific gravity _____	
Open-circuit voltage, V _____	
Tire pressure before test, psi	
Right front _____	Left front _____ Right rear _____ Left rear _____
Tire pressure after test, psi	
Right front _____	Left front _____ Right rear _____ Left rear _____
Fifth-wheel pressure, psi _____ (calibrated, _____ psi)	
Weather	Initial During test Final
Temperature, °F	_____
Wind speed, mph	_____
Wind direction	_____
Pressure, in. Hg	_____
Battery temperature, °F	Before _____ After _____
Motor temperature, °F	Before _____ After _____
Time Start _____	Stop _____
Odometer reading, miles	Start _____ Stop _____
Current out, Ah _____	Current in (regenerative), Ah _____
Fifth wheel _____	
Basis for termination of tests _____	
Charge data	
Average post-test specific gravity _____	
Open-circuit voltage, V _____	
Charger used _____	
Charger input voltage, V _____	
Battery temperature, °F	Before charge _____ After charge _____
Power, kWh	Start _____ End _____ Total _____
Time Start _____	End _____
Total charge time, min _____	
Current input, Ah _____	
Average specific gravity after charge _____	
Approval _____	

Figure D-4 - Track and charge data.

1. Record time immediately at completion of test. Turn off key switch.
2. Complete track data sheet:
 - (a) Odometer stop
 - (b) Ampere-hour integrator
 - (c) 5th wheel distance
 - (d) Read temperature
 - (e) Calibrate data system
 - (f) Record weather data
3. Turn off inverter, thermocouple reference junctions.
4. Disconnect 12-volt instrument battery red lead
5. Raise 5th wheel
6. Tow vehicle off track
7. Start charge procedure (specific gravities).
8. Check specific gravity on instrument battery. If less than 1.220, remove from vehicle and charge to full capacity
9. Check water level in accessory batteries. Add water as necessary.

Figure D-5. - Post-test checklist

Vehicle _____	Test _____	Date _____
Test conditions		
Temperature, °F _____	Wind speed, mph _____	at _____
Barometer reading, in. Hg _____, Other _____		
Test results:		
Test time, h _____		
Range, miles _____		
Cycles _____		
Current out of battery, Ah _____		
Current into battery, Ah _____		
Charge time, h _____		
Power into battery, kWh _____		
Magnetic tape:		
No _____, Speed, in/s _____		
Comments _____		

Figure D-6 - Test summary sheet

Vehicle _____	Test _____	Date _____
Engineer _____		
Reason for test (checkout, component check, scheduled test, etc) _____		
Limitation on test (malfunction, data system problem, brake drag, etc) _____		
Changes to vehicle prior to test (repair, change batteries, etc) _____		
Other comments _____		
Evaluation of test:		
Range, miles _____		
Current out, Ah _____		
Current in, Ah _____		
Power in, kWh _____		
Energy consumption, kWh/mile _____		
Was planned driving cycle followed? _____		
General comments _____		

Figure D-7. - Engineer's data sheet

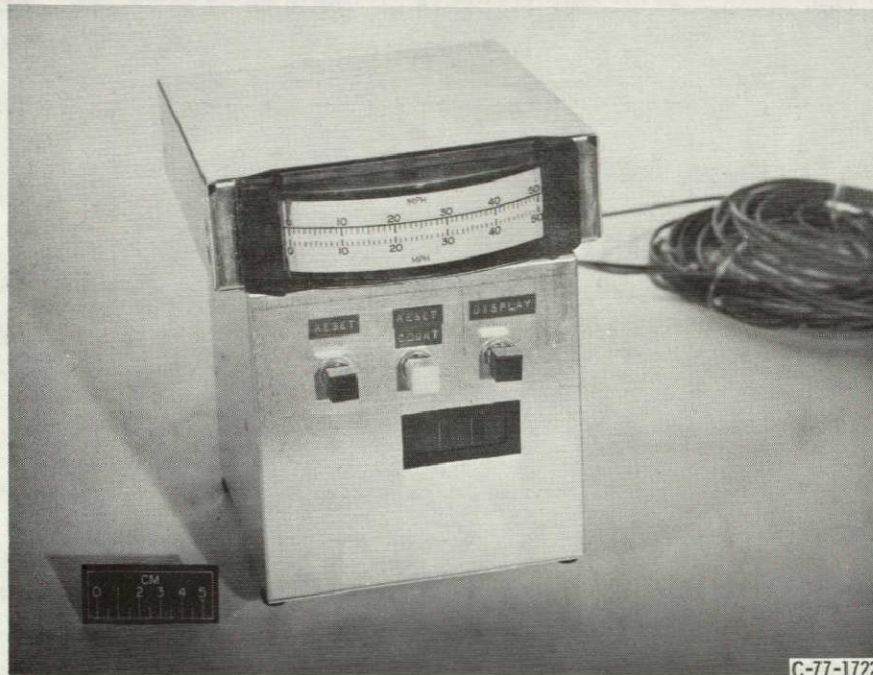

C-77-1722

Figure D-8. - Cycle timer.

□=20% DISCHARGE
 X=40% DISCHARGE
 H=80% DISCHARGE

VEHICLE PERFORMANCE
 EVA CONTACTOR (MARK II)

DATE RECORDED
 APRIL 15, 1977

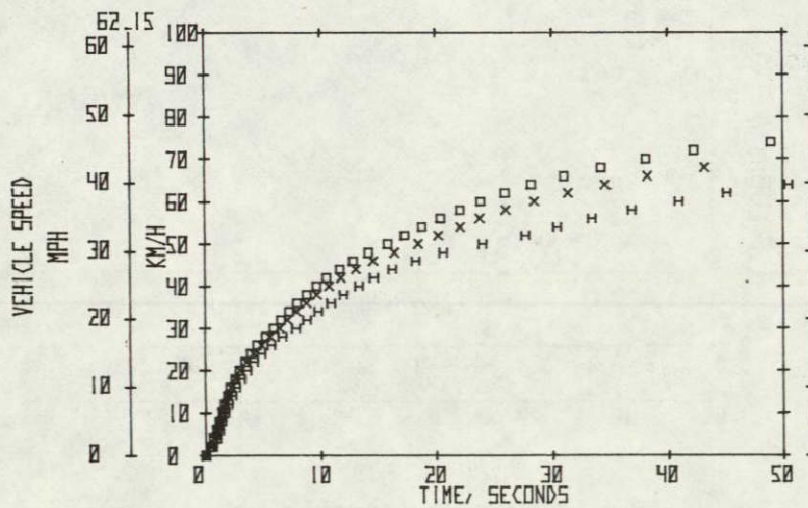

Figure E-1. - Vehicle acceleration.

ORIGINAL PAGE IS
 OF POOR QUALITY.

O=2X DISCHARGE
 X=40X DISCHARGE
 H=80X DISCHARGE

VEHICLE PERFORMANCE
 EVA CONTACTOR (MARK II)

DATE RECORDED
 APRIL 15, 1977

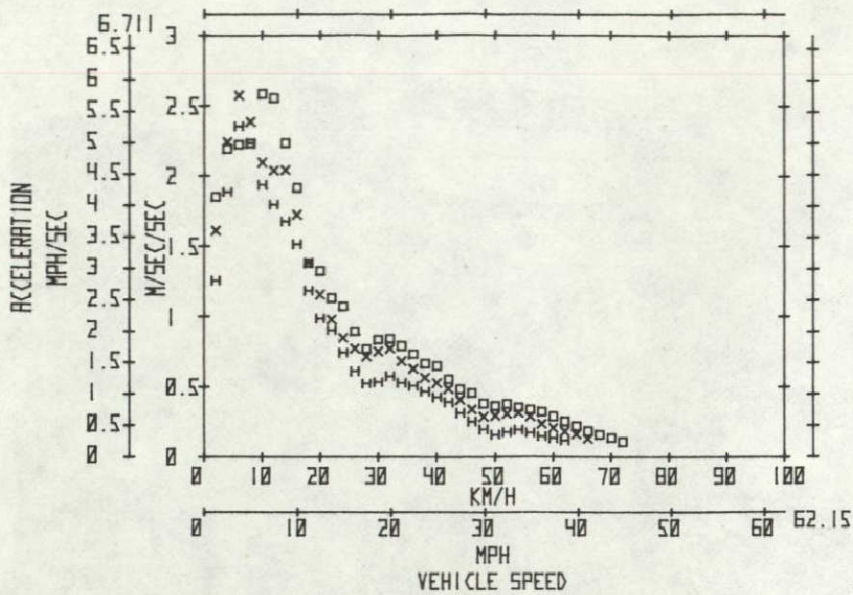

Figure E-2. - Acceleration as a function of speed.

O=2X DISCHARGE
 X=40X DISCHARGE
 H=80X DISCHARGE

VEHICLE PERFORMANCE
 EVA CONTACTOR (MARK II)

DATE RECORDED
 APRIL 15, 1977

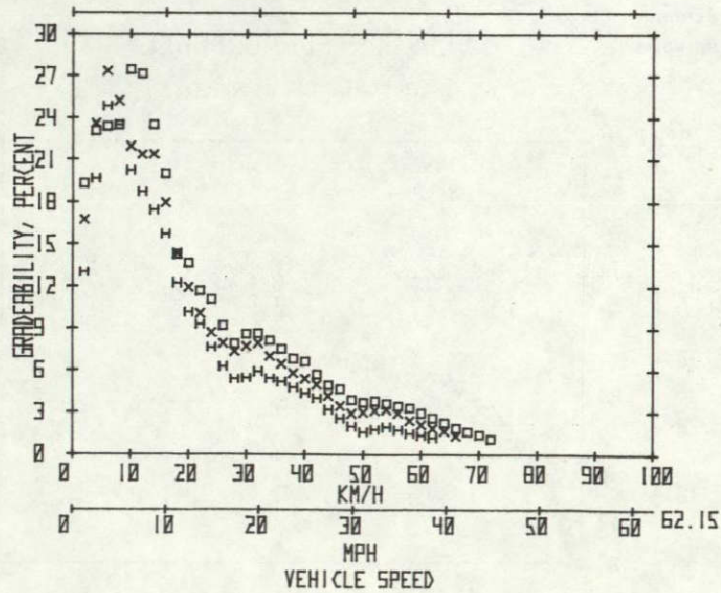

Figure E-3. - Gradeability as a function of speed.

NATIONAL AERONAUTICS AND SPACE ADMINISTRATION
WASHINGTON, D C 20546

OFFICIAL BUSINESS
PENALTY FOR PRIVATE USE \$300

SPECIAL FOURTH-CLASS RATE
BOOK

POSTAGE AND FEES PAID
NATIONAL AERONAUTICS AND
SPACE ADMINISTRATION
451



POSTMASTER

If Undeliverable (Section 158
Postal Manual) Do Not Return
