

# NASA TECHNICAL MEMORANDUM

NASA TM X-64755

Revision A

(NASA-TM-x-64755-Rev-A) GUIDELINES FOR THE  
SELECTION AND APPLICATION OF TANTALUM  
ELECTROLYTIC CAPACITORS IN HIGHLY RELIABLE  
EQUIPMENT (NASA) 68 p HC A04/MF A01

N78-18311

Unclas  
05713

CSCS 09A G3/33

## GUIDELINES FOR THE SELECTION AND APPLICATION OF TANTALUM ELECTROLYTIC CAPACITORS IN HIGHLY RELIABLE EQUIPMENT

By Dr. A. M. Holladay  
Electronics and Control Laboratory

January 31, 1978

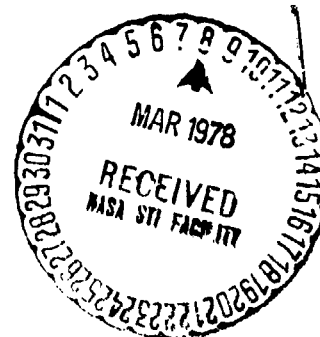

NASA

*George C. Marshall Space Flight Center  
Marshall Space Flight Center, Alabama*

TECHNICAL REPORT STANDARD TITLE PAGE

1. REPORT NO. NASA TM X-64755, Revision A	2. GOVERNMENT ACCESSION NO.	3. RECIPIENT'S CATALOG NO.	
4. TITLE AND SUBTITLE Guidelines for the Selection and Application of Tantalum Electrolytic Capacitors in Highly Reliable Equipment		5. REPORT DATE January 31, 1978	6. PERFORMING ORGANIZATION CODE
		8. PERFORMING ORGANIZATION REPORT #	
7. AUTHOR(S) Dr. A. M. Holladay		10. WORK UNIT NO.	
9. PERFORMING ORGANIZATION NAME AND ADDRESS George C. Marshall Space Flight Center Marshall Space Flight Center, Alabama 35812		11. CONTRACT OR GRANT NO.	
		13. TYPE OF REPORT & PERIOD COVERED Technical Memorandum	
12. SPONSORING AGENCY NAME AND ADDRESS National Aeronautics and Space Administration Washington, D. C. 20546		14. SPONSORING AGENCY CODE	
		15. SUPPLEMENTARY NOTES Prepared by Electronics and Control Laboratory, Science and Engineering	
16. ABSTRACT <p>This document supersedes NASA TM X-64755, dated February 1, 1973. It presents guidelines for the selection and application of three types of tantalum electrolytic capacitors in current use at MSFC in the design of electrical and electronic circuits for space flight missions. In addition, the guidelines supplement requirements of existing Military Specifications used in the procurement of capacitors. A need exists for these guidelines to assist designers in preventing some of the recurring, serious problems experienced with tantalum electrolytic capacitors in the recent past. The three types of capacitors covered by these guidelines are: solid (CSR09 and 13), wet foil (CLR25, 27, 35, and 37), and tantalum cased wet slug (CLR79).</p>			
17. KEY WORDS		18. DISTRIBUTION STATEMENT Unclassified - Unlimited	
19. SECURITY CLASSIF. (of this report) Unclassified	20. SECURITY CLASSIF. (of this page) Unclassified	21. NO. OF PAGES 68	22. PRICE NTIS

## TABLE OF CONTENTS

	Page
I. GENERAL .....	1
A. Purpose .....	1
B. Types of Tantalum Capacitors and Applicable Military Specifications .....	1
C. Applicable Documents .....	2
D. Definitions/Discussions of Terms .....	2
E. General Selection Guidelines .....	8
F. Preferred Applications Guidelines .....	9
G. Recommended Failure Rate Levels .....	11
H. Recommended Temperature Ranges .....	11
I. Hermetic Seals .....	11
J. General Electrical Characteristics .....	12
K. Dielectric Absorption .....	12
L. Tantalum Capacitor Packs .....	14
M. Mounting .....	15
N. Destructive or Failure Analysis of Wet Types .....	15
O. Construction .....	16
F. Control of Forward and Reverse Voltage on Wet Types ..	16
Q. Barometric Pressure .....	17
R. Radiation .....	17
S. Series-Parallel Applications .....	17
II. SOLID TANTALUM CAPACITORS .....	18
A. Construction .....	18
B. Applications at Different Frequencies .....	19
C. Applications at Different Temperatures .....	21
D. Permissible ac Voltage and Current .....	23
E. Temperature Rise Limitation Due to ac Ripple .....	28
F. Dielectric Protection .....	28
G. Self-Generated EMF .....	34
H. Reverse Bias .....	34

## TABLE OF CONTENTS (Concluded)

	Page
III. WET FOIL TANTALUM CAPACITORS . . . . .	35
A. Construction . . . . .	35
B. Applications at Different Frequencies and Temperatures . . . . .	36
C. Permissible ac Ripple . . . . .	41
D. Temperature Rise Limitation Due to ac Ripple . . . . .	41
E. Dielectric Protection . . . . .	41
F. Vibration Protection . . . . .	45
IV. TANTALUM CASED WET SLUG TANTALUM CAPACITORS . . . . .	47
A. Construction . . . . .	47
B. Applications at Different Frequencies and Temperatures . . . . .	48
C. Permissible ac Ripple . . . . .	53
D. Dielectric Protection . . . . .	54
E. Surge Tolerance . . . . .	54
F. Protection from Hydrogen Pressure . . . . .	55
G. Voltage Derating . . . . .	58
H. Spike Protection . . . . .	58

## LIST OF ILLUSTRATIONS

Figure	Title	Page
1.	Capacitors and phase relations . . . . .	4
2.	Equivalent circuit of a capacitor . . . . .	6
3.	RMS values of some common waveforms . . . . .	7
4.	Typical dielectric absorption of solid-electrolyte tantalum capacitors at 25°C . . . . .	14
5.	Construction features — solid tantalum electrolytic capacitor . . . . .	18
6.	Capacitance versus frequency for typical solid tantalum capacitors at 25°C . . . . .	19
7.	Typical curves of impedance versus frequency at various temperatures for solid tantalum 47 $\mu$ F, 35 V capacitors . . . . .	20
8.	Dissipation factor versus frequency for typical solid tantalum capacitors at 25°C . . . . .	21
9.	Typical curves of impedance, capacitance, and ESR versus temperature for 330 $\mu$ F, 6 V capacitors . . . . .	22
10.	Typical curves of impedance, capacitance, and ESR versus temperature for 68 $\mu$ F, 20 V capacitors . . . . .	22
11.	Typical curves of impedance, capacitance, and ESR versus temperature for 6.8 $\mu$ F, 35 V capacitors . . . . .	23
12.	Typical curves of impedance, capacitance, and ESR versus temperature for 47 $\mu$ F, 35 V capacitors . . . . .	23
13.	Permissible ripple voltage versus capacitance and ambient temperature at 120 Hz (style CSR13) . . . . .	24

## LIST OF ILLUSTRATIONS (Continued)

Figure	Title	Page
14.	Permissible ripple voltage versus capacitance and frequency at 25°C (style CSR13) . . . . .	25
15.	Maximum permissible ripple voltage as a function of frequency for case size A (style CSR13) . . . . .	26
16.	Maximum permissible ripple voltage as a function of frequency for case size B (style CSR13) . . . . .	26
17.	Maximum permissible ripple voltage as a function of frequency for case size C (style CSR15) . . . . .	27
18.	Maximum permissible ripple voltage as a function of frequency for case size D (style CSR13) . . . . .	27
19.	DC leakage current versus applied voltage for solid tantalum capacitor . . . . .	30
20.	Failure rate versus temperature. . . . .	31
21.	Maximum recommended voltage spikes for solid tantalum capacitors . . . . .	33
22.	Construction features — wet foil tantalum capacitor. . . . .	35
23.	Effect of frequency on capacitance of typical foil type tantalum capacitors at 25°C . . . . .	36
24.	Impedance curves for tantalum foil capacitors at 25°C . . . . .	37
25.	Tantalum foil impedance correction factors for capacitance up to 2 $\mu$ F . . . . .	37
26.	Tantalum foil impedance correction factors for capacitance of 2 to 50 $\mu$ F. . . . .	38

## LIST OF ILLUSTRATIONS (Continued)

Figure	Title	Page
27.	Tantalum foil impedance correction factors for capacitance of 50 $\mu$ F and over . . . . .	38
28.	Typical curves of impedance with frequency at various temperatures for 200 $\mu$ F, 6 V plain foil capacitors . . . . .	38
29.	Typical curves of impedance, capacitance, and ESR with temperature for 26 $\mu$ F, 100 V polarized etched foil capacitors . . . . .	39
30.	Effect of frequency on dissipation factor of foil type tantalum capacitors . . . . .	40
31.	Typical curve of the ratio of dc leakage current at rated voltage versus temperature for foil tantalum capacitors . . . . .	40
32.	Maximum allowable ripple voltage and current for styles CLR25, 27, 35, and 37 foil capacitors at 60 Hz . . . . .	42
33.	Correction factor for maximum allowable ripple current and voltage versus frequency for tantalum foil capacitors . . . . .	43
34.	Correction factor for maximum allowable ripple voltage versus temperature for tantalum foil capacitors . . . . .	43
35.	Typical effects of applied dc voltage on failure rate of foil capacitors . . . . .	44
36.	Typical effects of temperature on failure rate of foil capacitors . . . . .	44

## LIST OF ILLUSTRATIONS (Continued)

Figure	Title	Page
37.	Maximum recommended voltage spikes for foil tantalum capacitors . . . . .	45
38.	Construction features — tantalum cased wet slug tantalum capacitor . . . . .	47
39.	Effects of temperature on capacitance of CLR79 capacitors (T2 case) . . . . .	48
40.	Effects of temperature on capacitance of CLR79 capacitors (T3 case) . . . . .	49
41.	Effects of temperature on capacitance of CLR79 capacitors (T4 case) . . . . .	49
42.	Typical curves of impedance with frequency at various temperatures for wet slug 560 $\mu$ F, 6 V capacitors . . . . .	50
43.	Typical curves of impedance with frequency at various temperatures for wet slug 25 $\mu$ F, 125 V capacitors . . . . .	50
44.	Effects of frequency on ESR of wet slug capacitors of various ratings . . . . .	51
45.	Typical curves of ESR as a function of temperature for capacitors of various ratings . . . . .	52
46.	Effects of applied dc voltages on dc leakage of CLR79 capacitors . . . . .	52
47.	Typical T1 case temperature rise as a function of ripple current . . . . .	53
48.	Typical T2 case temperature rise as a function of ripple current . . . . .	53



## LIST OF ILLUSTRATIONS (Concluded)

Figure	Title	Page
49.	Typical T3 case temperature rise as a function of ripple current . . . . .	54
50.	Typical T4 case temperature rise as a function of ripple current . . . . .	54
51.	Effects on capacitance and dc leakage of current-surge tests on CLR79 capacitors . . . . .	55

TECHNICAL MEMORANDUM 64755

Rev. A

GUIDELINES FOR THE SELECTION AND APPLICATION  
OF TANTALUM ELECTROLYTIC CAPACITORS  
IN HIGHLY RELIABLE EQUIPMENT

I. GENERAL

A. Purpose

The purpose of this document is to provide guidelines which supplement requirements of existing Military Specifications (MIL-SPEC) for tantalum capacitors used in space flight missions. These guidelines are intended to optimize the selection and application of these capacitors in space electronic hardware.

B. Types of Tantalum Capacitors and Applicable  
Military Specifications

<u>Type</u>	<u>Style/ Rating</u>	<u>Military Specification</u>
Solid Tantalum	CSR09 (6 to 75 V)	MIL-C-39003/2
Solid Tantalum	CSR13 (6 to 75 V)	MIL-C-39003/1
Polarized Etched Foil	CLR25 (15 to 150 V)	MIL-C-39006/1
Nonpolarized Etched Foil	CLR27 (15 to 150 V)	MIL-C-39006/2
Polarized Plain Foil	CLR35 (15 to 300 V)	MIL-C-39006/3
Nonpolarized Plain Foil	CLR37 (15 to 300 V)	MIL-C-39006/4
Tantalum Cased Wet Slug	CLR79 (6 to 125 V)	MIL-C-39006/22

Note: MIL-C-39006 covers established reliability styles. Obsolescent MIL-C-3965 covers similar styles for replacement purposes only. These specifications give capacitance tolerances, temperature ranges, etc. Solid tantalum chip style capacitors styles CWR02-08 are omitted from this document. They are included in MIL-C-55365 and in Section 803 of MIL-STD-198D.

## C. Applicable Documents

<u>Military Specification</u>	<u>Title</u>
MIL-C-39003	Capacitors, Fixed, Electrolytic (Solid Electrolyte) Tantalum, Established Reliability, General Specification For
MIL-C-39006	Capacitors, Fixed, Electrolytic (Nonsolid Electrolyte) Tantalum, Established Reliability, General Specification For
MIL-STD-198D	Capacitors, Selection and Use of (November 8, 1976)
MIL-HDBK-217B	Reliability Prediction of Electronic Equipment (September 20, 1974)

## D. Definitions/Discussions of Terms

1. AC Ripple — The alternating current superimposed on the dc bias on a capacitor.

2. Ambient Temperature — The average temperature of the medium (air, liquid, etc.) surrounding an object.

3. Capacitance — The coulombs per volt which a capacitor can store. It is usually expressed in microfarads ( $10^{-6}$  F) or picofarads ( $10^{-12}$  F).  $C = Q/V$ . Capacitance is proportional to dielectric constant and area, but is inversely proportional to thickness; i.e.,

$$C = \frac{K \times A}{t}$$

A capacitor has a capacitance of 1 F if it can store 1 C of charge ( $6.24 \times 10^{18}$  electrons) with a potential of 1 V across its plates.

4. Capacitance Reactance ( $X_c$ ) — The nonheating impedance component of the capacitor when ac flows; i.e.,

$$X_c = \frac{1}{2\pi fC}$$

It is to be noted that as the frequency changes the capacitance also changes (decreases as frequency increases); therefore,  $X_c$  does not change linearly with frequency.

5. Capacitor — An electrical/electronic part that stores/discharges electrical charges. In its simplest form it consists of two conducting surfaces separated by a dielectric.

6. Dielectric — The "insulator" between two or more conducting plates of a capacitor. In the tantalum capacitor it is amorphous  $Ta_2O_5$ . The dielectric is not the electrolyte. It preferably has a highly polar structure with high breakdown voltage.

7. Dielectric Absorption — The delay of flow of charges into and out of a capacitor caused by the inertia of dipoles in the dielectric in an electrostatic field, resulting in a decrease in effective capacitance.

8. Dielectric Constant — The ratio of the coulombs per volt (capacitance) which a capacitor of a given plate area and a dielectric of given thickness can store and the coulombs per volt which can be stored by a capacitor of the same dimension with a dielectric of vacuum with the same thickness. Dielectric constants for most capacitors range from approximately 1 to 15 000. The dielectric constant for  $Ta_2O_5$  is approximately 28. Its value depends upon the dipolarity of the dielectric material (molecules, crystals, etc.) under given conditions, and should not be confused with breakdown voltage.

9. Dielectric Strength — The maximum voltage that a dielectric can withstand without rupturing. The value depends on the type of material, temperature, conditions of test, etc.

10. Dissipation Factor (DF) — A measure of the efficiency or power loss of a capacitor. The DF is expressed mathematically as

$$DF = \tan \theta = \frac{ESR}{X_c}$$

where  $\theta$  is the difference between the phase angle and 90 deg. In a perfect capacitor, the current leads the voltage by 90 deg. Since there is no perfect capacitor, the lead is less than this, especially in electrolytics. The larger the capacitance, the higher the frequency, and the colder the capacitor, the higher the DF reading. The power factor (PF) is expressed mathematically as

$$\sin \theta = \frac{ESR}{Z}$$

and is virtually the same as DF up to 15 percent (Fig. 1).

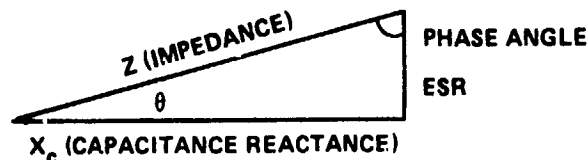

Figure 1. Capacitors and phase relations.

11. Electrolyte — The medium through which charges are conducted to and from the dielectric interfaces. There are two types of electrolytes: "solid," made of  $MnO_2$  from the pyrolysis of  $Mn(NO_3)_2$ ; and "wet," made from various liquids. Common wet electrolytes for tantalum capacitors are sulfuric acid (40 to 50 percent, sometimes gelled with finely divided  $SiO_2$ ), lithium chloride (for devices below 60 working volts), and organic solvent/inorganic salt combinations. "Depolarizing" agents are sometimes added to help suppress hydrogen formation on the cathode during operation.

12. Energy Storage — The amount of energy stored or discharged from a capacitor is usually expressed in joules or microjoules. The expression defining this value in joules is:

$$J = \frac{1}{2} CV^2 = \frac{QV}{2} ,$$

where C is in farads. For microjoules,

$$\mu J = \frac{1}{2} CV^2 ,$$

where C is in microfarads. It is to be noted that time is not a factor in these equations, and the joule value does not depend upon the rate of discharge; i. e.,

$$1J = 1 \text{ watt-seconds} .$$

13. Equivalent Series Resistance (ESR) — The total resistance a capacitor offers to the flow of ac. ESR decreases with increasing frequency and temperature up to a point. ESR is the "heating component" or "copper loss" in a capacitor which produces heat ( $I^2R$  loss) when ac flows. In the tantalum capacitor, the chief contributor to ESR is the resistance of the electrolyte. The least resistive electrolyte is  $MnO_2$  in the solid capacitor; the next least resistive is sulfuric acid, then lithium chloride, and then various organic solvent/inorganic salt solutions. Equivalent series resistance is expressed mathematically as

$$ESR = X_c \tan \theta = Z \sin \theta$$

Figure 2 shows where ESR occurs in the equivalent circuit of a capacitor.

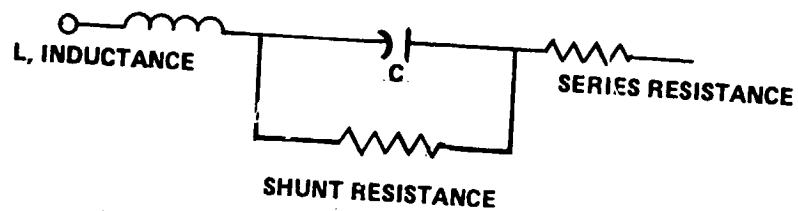

Figure 2. Equivalent circuit of a capacitor.

14. Impedance — Total opposition offered to the flow of alternating or pulsating current measured in ohms. As shown in Figure 2, impedance is the vector sum of ESR and  $X_c$ . As frequency increases,  $X_c$  decreases and  $X_L$  (inductance reactance) increases. At some frequency, the  $X_c$  and  $X_L$  terms cancel out. Then, ESR and Z are equal and the capacitor resonates and appears as a resistor in the circuit. Impedance is expressed mathematically as

$$Z = \sqrt{ESR^2 + (X_c - X_L)^2}$$

15. Insulation Resistance (IR) — Direct current resistance between two conductors which are separated by an insulator. A capacitor's IR can be measured between the two terminals (which also gives dc leakage) and between one or more terminals and the case insulation sleeve. IR is expressed in megohms or megohm-microfarads and dc leakage is expressed in microamperes.

16. Peak ac/Root Mean Square (RMS) — The peak voltage measured from the center of the sine wave to the top. RMS applies to voltage or current, and for a sine wave equals 0.7 of the peak voltage or current. For an alternating square wave, it is the same as the peak voltage or current. Various waveforms are given in Figure 3, and the conversion of peak to RMS, and vice versa. The recommended ratings for sine wave application may be extended to other waveforms by solving for the equivalent RMS voltage of the waveform in question. The appropriate formulas are given in Figure 3.

17. Permissible ac Ripple — The maximum RMS ac voltage or current that may be applied to a capacitor under certain prescribed conditions. A capacitor may be operated with an impressed ripple (ac) voltage, provided all the following requirements are met:

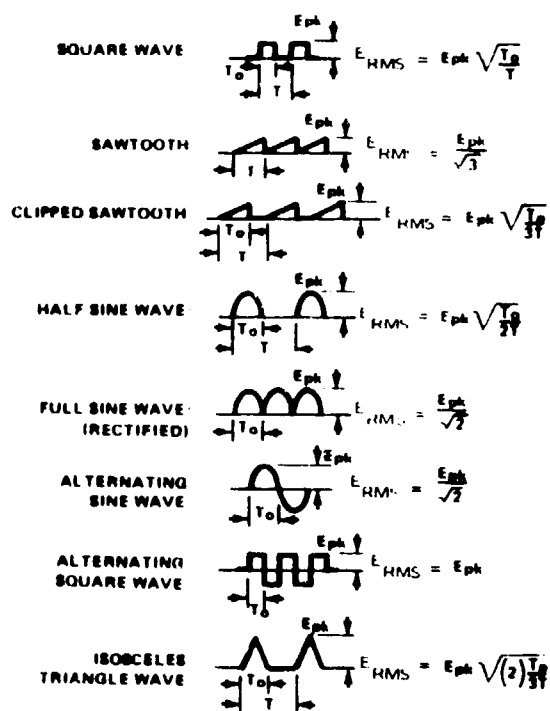

Figure 3. RMS values of some common waveforms.

- The sum of peak ac voltage and dc polarizing voltage (if any) does not exceed the rated voltage.
- For polarized styles, sufficient dc polarizing voltage is applied to prevent polarity reversal at any point.
- The heat dissipation limits of the capacitor are not exceeded.

The maximum permissible ripple voltage may be determined from the calculated permissible ripple current, or conversely, using the following equation:

$$I_{ac} = E_{ac} 2\pi f C 10^{-6}$$

where

$$I_{ac} = \text{amperes ac (RMS)}$$

$$E_{ac} = \text{volts ac (RMS)}$$



$f$  = frequency (Hz)

$C$  = capacitance ( $\mu\text{F}$ ).

This formula is based on  $X_c$  rather than  $Z$ , and is therefore approximate.

18. Plates — The conducting surfaces of a capacitor adjacent to the dielectric. One or more plates are positive, and one or more are negative. The plate may be tantalum foil, a tantalum slug (made of sintered tantalum grains), tantalum case, or other materials for the cathode. Technically, a wet tantalum electrolytic has two capacitors in series. On the anode, the positive plate is tantalum and the cathode is the electrolyte; on the cathode, the positive plate is the electrolyte and the cathode is the case for the slug type and the case and foil for the foil type. For the solid tantalum, the anode is the slug and the cathode is  $\text{MnO}_2$  adjacent to the  $\text{Ta}_2\text{O}_5$  dielectric. The effective series capacitance is the product of the anode and cathode capacitance divided by the sum of the two.

19. Spike — A momentary sharp increase and then decrease in voltage/current in a circuit (synonymous with transient).

## E. General Selection Guidelines

1. Determine circuit parameters, such as steady-state dc voltage, peak dc voltage, peak ac current, waveform (pulse width, repetition rate and rise time, etc.) steady-state ac ripple, and frequency. Oscillograms are recommended.

2. Determine environmental operating conditions of the circuit: (a) maximum-minimum operating ambient temperatures, (b) shock, (c) vibration, (d) humidity, and (e) temperature cycling.

3. Select a capacitor type from F in terms of the previously mentioned operating requirements and guidelines in this document.

4. Gather and review the following technical data from vendor and specs on the selected capacitor: (a) capacitance and tolerance, (b) capacitance change over the operating temperature, (c) dissipation factor, (d) DF change over the

operating temperature, (e) ESR and its change with operating temperature, (f) dc leakage and its change with temperature, (g) insulation resistance, (h) permissible ac voltage and current at operating frequency, and (i) permissible temperature rise due to ac ripple.

5. Verify that the proposed capacitor is optimum for the application. If not, repeat the selection process. Given the previously mentioned information, the applications engineer can usually select the proper capacitor with confidence. He may indeed find that he cannot use an electrolytic capacitor.

## F. Preferred Applications Guidelines

Generally, tantalum electrolytics are used in applications requiring high capacitance per unit volume and weight, with large tolerances. Such applications include blocking, filtering, bypassing, coupling, and energy storage. When used in phase shifting circuits, the DF must be taken into consideration. Their use in pulsing and raw ac applications should be cautious and subject to verification experiments for the particular application. These capacitors are preferred to other types in applications requiring long life and high reliability.

Following are some general guidelines in selecting capacitors for certain applications. The rationale for these guidelines will be presented later in this report.

1. Solid Tantalum (CSR09 and 13). The solid tantalum (CSR09 and 13) capacitors are preferred for the following applications:

- a. Circuits which deliver less than 0.33 A to a shorted capacitor.
- b. Circuits that do not generate spikes and which, in turn, are not sensitive to scintillations produced by "self-healing" of the capacitor.
- c. Circuits with steady-state peak voltages less than 45 V (up to 85°C).
- d. Circuits which are not sensitive to electromotive force (EMF) generated by the capacitor.

e. Low temperature applications in which high ESR is intolerable and minimum changes in capacitance, DF, and impedance are desired.

f. High vibration and shock applications (up to 100 g-RMS).

2. Wet Foil Type (CLR25, CLR27, CLR35, and CLR37). These foil capacitors are the most versatile of the tantalum electrolytics since they are available in polar and nonpolar forms and plain and etched foil (up to 300 V). However, they generally have higher dc leakage, DF, and volume per microfarad-volt than do the slug types, and have less stable frequency and temperature characteristics.

The foil type capacitors are preferred for the following applications:

a. Circuits with the possibility of reverse voltage above 3 V (use nonpolar types).

b. Operating voltages greater than those that can be tolerated by solid or wet slug tantalums (see voltage ratings under each type).

c. Applications with relatively low vibration levels (below 65 g-RMS).

d. Applications in which fairly large changes in capacitance with temperature and high ESR, especially at cold temperatures, can be tolerated.

e. Circuits which can tolerate relatively high dc leakage, in the micro-ampere range. (When used for low-frequency coupling in transistor or vacuum tube circuits, high dc leakage can cause improper positive bias to be applied across the grid circuits, or excessive base, emitter, or collector currents. It should be noted that dc leakage may increase drastically as temperature increases.)

f. Nonpolar types are primarily suitable for ac applications or where dc voltage reversals occur, such as in tuned low-frequency circuits, phasing of low voltage ac motors, in computer circuits in which dc voltage reversal occurs, or in servo systems.

3. Tantalum Cased Wet Slug (CLR79). The tantalum cased wet slug (CLR79) capacitor is preferred for the following applications:

- a. High ripple current applications such as in power supply and bus filtering.
- b. Low dc leakage applications, such as timing circuits.
- c. Circuits which produce spikes and transients.
- d. High in-rush current applications, such as input filtering.
- e. Applications requiring up to 3 V reverse bias.

Note: Wet slug capacitors using cathode cases other than tantalum are not recommended for flight purposes.

## G. Recommended Failure Rate Levels

Failure rate levels P, R, and S (0.1, 0.01, and 0.001 percent/1000 h failure rate respectively, all at a 60 percent confidence level) are recommended. Failure rates L and M are not recommended.

### Rationale

Failure rate levels L and M do not include sufficient test data or offer enough evidence of product maturity for high reliability space hardware. Failure modes are opens, shorts, intermittents, and parameter drift (capacitance, ESR, impedance, and dc leakage).

## H. Recommended Temperature Ranges

These electrolytic capacitors can operate safely over a range of -55 to 125°C. Because of hermetic seals, these capacitors should operate at 85°C for at least 10 000 h at full rated voltage without serious deterioration. Derating is required above 85°C.

## I. Hermetic Seals

It is recommended that all tantalum capacitors be hermetically sealed.

## Rationale

Nonsolid (wet) electrolyte tantalums may lose electrolyte in the vacuum of space or on Earth. These electrolytes are corrosive and will attack other components on the PC board and may cause high dc leakage. Solid electrolytic capacitors which are not hermetically sealed can absorb moisture prior to launch and can subsequently deteriorate in space due to parameter drifts. These hermetic seals also permit virtually no limit to thermal cycling, and with no fear of electrolyte leakage.

## J. General Electrical Characteristics

1. To minimize inductance effects at higher frequencies, the use of slug type capacitors rather than foil types is recommended.
2. Maximum applied steady-state dc voltage should be no more than 60 percent of rated dc voltage at the respective temperatures up to 85°C and from 85°C to 125°C. The greater the derating, along with the use of physically smaller units, the more likely the following benefits will be achieved:
  - a. Lower dc leakage due to thicker oxide dielectric.
  - b. Lower ESR and DF.
  - c. Lower production of gaseous hydrogen on wet types.
  - d. Greater stability of dc leakage, ESR, DF,  $\mu F$ , and Z over the operating temperature range.
  - e. Better tolerance to spikes and transients due to a thicker oxide.

## K. Dielectric Absorption

It is recommended that the design engineer understand the effects of dielectric absorption on capacitance changes at different frequencies and the effects of residual charges on the capacitor that may affect the circuit.

### Rationale

Dielectric absorption (already defined) is an unfortunate characteristic of all capacitors. It is probably the least understood of capacitor problems. Dipoles in the dielectric require a finite time to orient themselves to the applied field. They also have certain relaxation moments and do not return to their previous orientation the moment the field is removed. Therefore, the charging or discharging of a capacitor is never complete, but is asymptotic. Electrons tend to behave in the dielectric as though some were "free," and others "bound." The practical result of this phenomenon is that as the frequency of the ac increases the electrons appear to be more and more bound, or "absorbed," and capacitance decreases. However, since ESR (the heating component) decreases as frequency increases, design engineers would do well to select frequencies for power supplies in the 10 to 20 kHz range rather than at lower frequencies, even though there is capacitance loss. The engineer must constantly bear in mind that the rating of capacitance, DF, ESR, and impedance are based on measurements taken at 120 Hz, and that these parameters may vary considerably from the 120 Hz reading when measured at other frequencies. Dielectric absorption is often a major factor in this variation.

Another manifestation of dielectric absorption is the reluctance of the dielectric to give up its charges and, consequently, the reappearance of potential across a capacitor after it has been charged, then shorted, and the short removed. This characteristic may be important in such applications as remote timing circuits, triggering systems, and phase shift networks. The curves of Figure 4 were generated by charging two solid tantalum capacitors at full rated voltage for 1 h, discharging through a dead short for 1 min, and then measuring voltage recovery with a high-impedance electrometer at the intervals shown on the curves. At higher temperatures, the curves shift to the left and the amplitude is less, but the shape is the same. If charge time is shorter, discharge time is longer, or charging voltage is less; then, the amplitude of the curves is reduced, but the shape and relative position are practically unaffected.

In interpreting this curve, one must be careful not to confuse dielectric absorption with internal EMF of the capacitor. Both forces are present, especially in the solid tantalum.

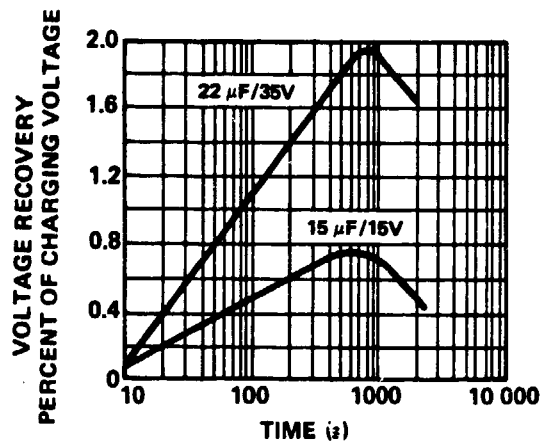

Figure 4. Typical dielectric absorption of solid-electrolyte tantalum capacitors at 25°C.

Thus, overall dielectric absorption depends upon (1) the structure and character of the dielectric, (2) amplitude of the charging voltage, (3) charging time, (4) elapsed time between discharge and time of measurement, and (5) temperature. As one would suspect, the dielectric absorption in a vacuum is zero, and is practically zero when air is the dielectric.

## L. Tantalum Capacitor Packs

These packs consist of several individual capacitors, solid or wet, connected in series/parallel, and usually embedded in epoxy in a hermetic case. Typically, they are used in filter applications where large capacitance values are required. The following recommendations are made:

1. Preferably, individual units should be hermetically sealed.
2. The internal temperature of the pack should be determined for the particular ac load.
3. The packs should be potted into an easily replaceable module.

### Rationale

1. Leaking electrolyte may cause high dc leakage, production of hydrogen, high internal pressure, and even rupture of the case (in case of wet types). If nonhermetic units are used, all anode connections should be made of heavy tantalum wire or ribbon, which would "form" in case of contact with electrolyte and thus minimize dc leakage. The use of CLR79 capacitors provides maximum CV product per unit volume, low dc leakage, and overall high reliability. In all cases the pack must be hermetically sealed.

2. The plastic encapsulant in the package does not dissipate heat well, and the applications engineer should know the internal temperature. This can be determined by inserting a thermistor or thermometer into the center of the pack while the plastic is molten and conducting the test after the plastic sets.

3. Sometimes all the packs are potted into a module for massive filtering purposes. If a pack fails, it is difficult to remove it by depotting. Therefore, potting should be done in such a way as to reduce cost and effort in making a retrofit.

## M. Mounting

It is recommended that capacitors be mounted in such a manner that the body and not the lead wires are subjected to stresses such as vibration and shock.

### Rationale

The lead wires are relatively small and may break during flight stresses. Also, they are encased in glass at least on one end, and stresses on the glass may shatter it and permit electrolyte to leak. Thus, plastic or band body mounting is recommended.

## N. Destructive or Failure Analysis of Wet Types

It is recommended that the capacitors be opened with care during any analysis.



### Rationale

The electrolyte may be under some pressure; therefore, it may squirt out and contact personnel or equipment and cause damage because of its corrosive nature. Generally, the electrolyte for tantalum slugs has approximately a 40 percent concentration of sulfuric acid. For foil types, a commonly used electrolyte consists of dimethylformamide/ethylene glycol as solvents, with some salt such as potassium thiocyanate.

No single detection method is adequate for all electrolytes; therefore, the composition of each electrolyte must be determined and effective testing methods devised. If it is known that the electrolyte is acidic, then blue litmus paper moistened in deionized water is an effective and sensitive test for detecting the presence of acid. However, care must be exercised to ensure that foreign substances such as soldering fluxes and body acids are not present, as this would result in a false positive test. If the electrolyte is neutral (pH 7) or its composition is unknown, a fine leak test per MIL-STD-202 may be used to check hermeticity of the case and a possible leakage of the electrolyte.

## O. Construction

In all types of tantalum capacitors, the anode riser wire should extend not more than 0.25 in. beyond the glass seal, and the external lead welded to the riser should be of adequate length to permit bending, insertion, and soldering in a PC board without compromising the weld integrity.

## P. Control of Forward and Reverse Voltage on Wet Types

It is recommended that voltage derating be used as stated under each type as a reliability consideration. It is also recommended that forward and reverse biases not exceed the rated levels.

### Rationale

Hydrogen gas may form on one of the electrodes, build up internal pressure, and cause the device to explode. This can be hazardous to both personnel and equipment.

## Q. Barometric Pressure

Since these capacitors are hermetically sealed and do not operate at high voltage, there is no problem in operating them in the vacuum of space. They will also tolerate pressures above 1 atm (29.9 in. of Hg or 760 mm), depending on size of case. The smaller cases tolerate a higher pressure, and the solid tantalum will withstand a higher crush strength than will the wet types. Generally, these capacitors will withstand at least 10 atm without a problem.

## R. Radiation

Electrolytics may undergo parameter changes from either ionizing or burst radiation, depending on dosage. The dielectric can be weakened, and dc leakage may rise as a result of bombardment. Unfortunately, tantalum itself has a heavy nucleus and can absorb neutrons readily. Therefore, caution is urged in using these capacitors in radiation fields (including solar flares) on space missions. Teflon parts used inside the capacitor also undergo marked degradation when bombarded with radiation, especially in the presence of oxygen.

## S. Series-Parallel Applications

If capacitors are hooked in series to permit higher voltage application, a shunt resistor should be hooked across each unit to prevent the capacitor with the lowest dc leakage from having the dc voltage across it too high. For parallel application in which the total capacitance equals the sum of the individual capacitances, two precautions should be observed. First, the rules regarding dc voltage and ac ripple levels given in Paragraph I.D Item 17 should be observed as in the case of individual units. Furthermore, the connecting leads of the parallel network should be large enough not to increase ESR and DF.

## II. SOLID TANTALUM CAPACITORS

The following recommendations and comments apply to all solid (CSR) type tantalum electrolytic capacitors.

### A. Construction

Figure 5 shows the construction features of a solid tantalum electrolytic capacitor.

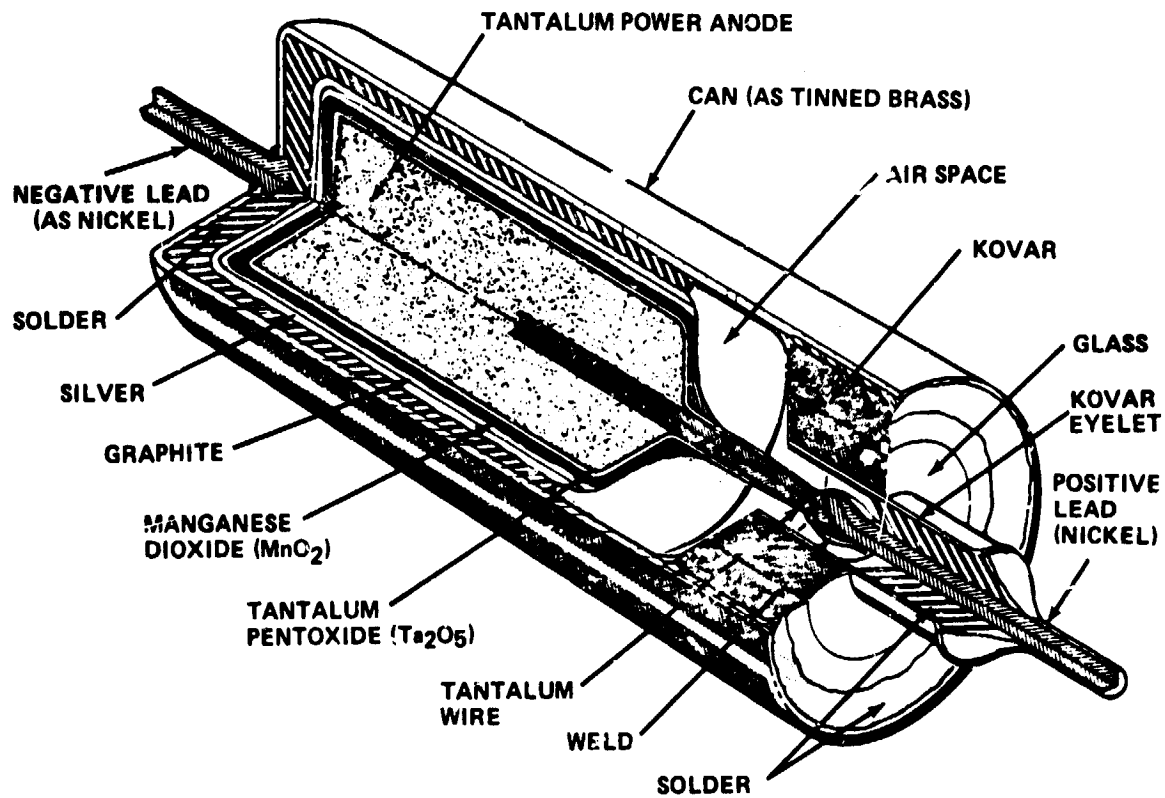

Figure 5. Construction features — solid tantalum electrolytic capacitor.

## B. Applications at Different Frequencies

It is recommended that the design and applications engineer determine the minimum electrical parameters required for the given frequency and, after studying the following curves, select the optimum capacitor type and rating for that application.

### Rationale

The rationale is given for each of the following parameters. Overall the solid tantalum capacitor is the most stable of the electrolytics with respect to changes in electrical parameters at different frequencies. Even so, some changes do occur, and the following curves of typical ratings should be studied as a guideline to selecting specific ratings of these capacitors for given applications. It should be noted that the values of electrical parameter rating are based on measurements made at room ambient and at 120 Hz, and that deviations appear under other conditions. Furthermore, it should be noted that these deviations are rarely if ever linear with frequency change.

1. Capacitance. Figure 6 shows the relative stability of capacitance with respect to frequency changes.

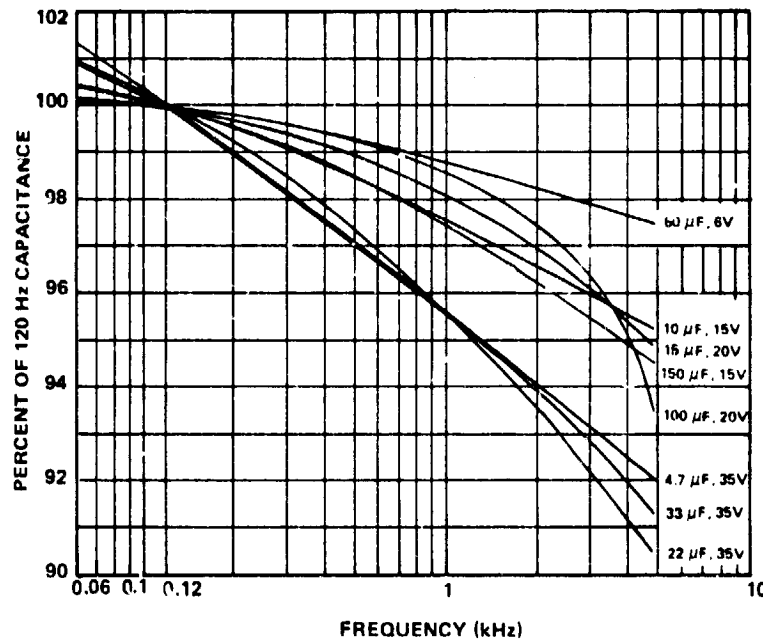

Figure 6. Capacitance versus frequency for typical solid tantalum capacitors at 25°C.

2. Impedance. Impedance is the hypotenuse of the vector triangle shown in Figure 1, and therefore changes as either  $X_c$  or ESR changes. Figure 7 shows that it consistently decreases as the frequency increases to 100 kHz, and then begins to increase. The trough of the curve is almost wholly resistive, and beyond 100 kHz the capacitor functions more as an inductor. The applications engineer must be cautious not to use electrolytics beyond 50 kHz.

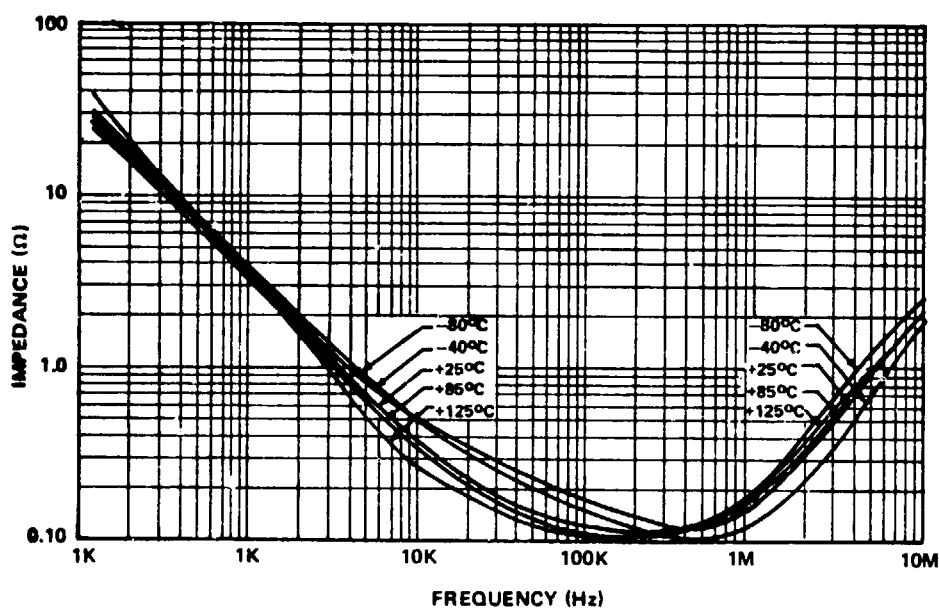

Figure 7. Typical curves of impedance versus frequency at various temperatures for solid tantalum 47  $\mu$ F, 35 V capacitors.

3. Equivalent Series Resistance. Typically, the ESR of solid tantalums is among the lowest of electrolytics. Its change with frequency is similar to the curves shown for impedance in Figure 7. This means that the design engineer can filter more amperes of ac at high frequency than at low frequency, since low ESR affords less  $I^2R$  loss.

4. Dissipation Factor. As shown in Figure 8, DF increases with frequency. Note that the small units have smaller changes. Design engineers should avoid the common error in thinking that DF produces heat, and that therefore filter circuits should be at low frequency to enjoy low DF. This is

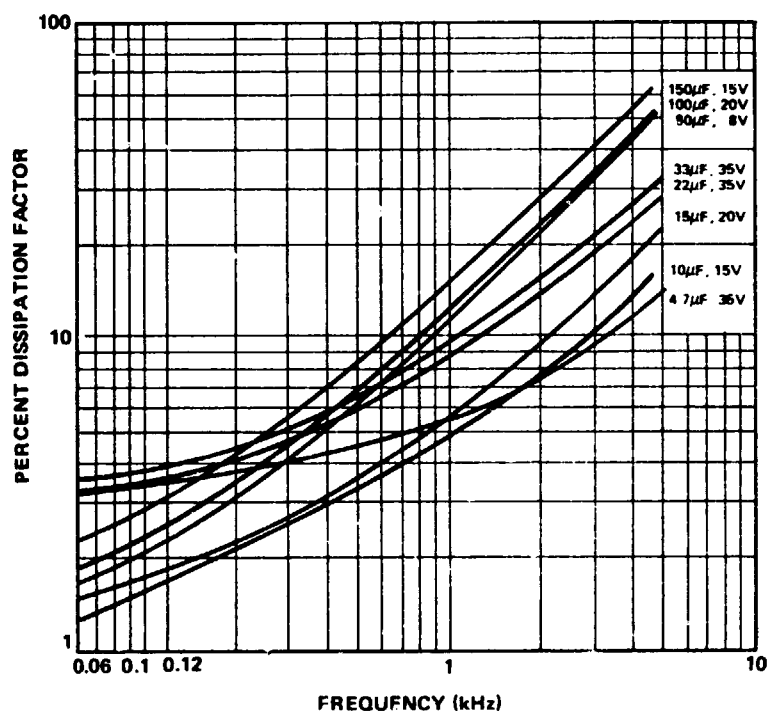

Figure 8. Dissipation factor versus frequency for typical solid tantalum capacitors at 25°C.

true for ESR, but not for DF. Recall that DF is a derived factor, namely,  $ESR/X_c$ . The rate of change of ESR is less than that for  $X_c$ : i.e., it decreases more slowly than does  $X_c$  as frequency increases. Hence, DF increases as frequency increases. This increase in DF with frequency should be taken into account in its effects on phase shifting. It should also be remembered that  $X_c$  changes nonlinearly with frequency since  $X_c = 1/2 \pi fC$ , and that change in frequency not only changes in the equation, but C also, in a nonlinear fashion.

### C. Applications at Different Temperatures

It is recommended that the design and applications engineer determine the temperature and temperature range over which the circuit will operate, and on the basis of the following data select the optimum capacitor rating and type for that application.

## Rationale

This recommendation is made for two reasons: (1) the change in electrical parameters experienced as temperature changes, and (2) the increase in failure rate as temperature increases.

Temperature variations affect capacitor parameters primarily because of changes in conductivity of the electrolyte and the changes in dielectric constant.

In addition to their relative stability over a wide range of frequency, the solid tantalums are also relatively stable over a wide temperature range with respect to capacitance and DF, but less so for ESR, and even less so for dc leakage. All parameters fare well at low temperatures because the solid electrolyte is a semiconductor and does not depend on ionic conduction as do the wet electrolytes. Therefore, one would expect ESR and related parameters to remain fairly stable.

Cold temperatures reduce ionization and ionic mobility of the wet types; therefore, one would expect the solid tantalums to exhibit rather outstanding temperature characteristics. The somewhat unpredictable values for ESR are doubtless caused by the changes in the contact resistance of the many interfaces in this capacitor and not necessarily to changes in the  $MnO_2$  itself.

1. Impedance, Capacitance, and Series Resistance. Typical curves of impedance, capacitance, and ESR versus temperature are shown in Figures 9 through 12.

Figure 9. Typical curves of impedance, capacitance, and ESR versus temperature for 330  $\mu F$ , 6 V capacitors.

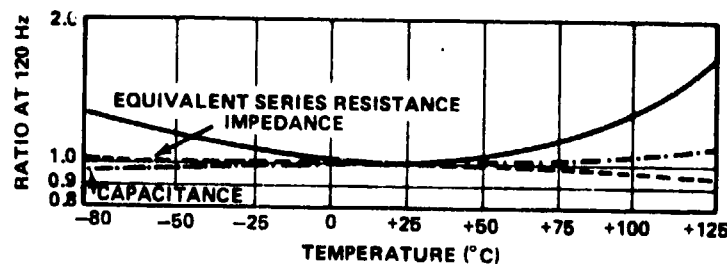

Figure 10. Typical curves of impedance, capacitance, and ESR versus temperature for 68  $\mu F$ , 20 V capacitors.

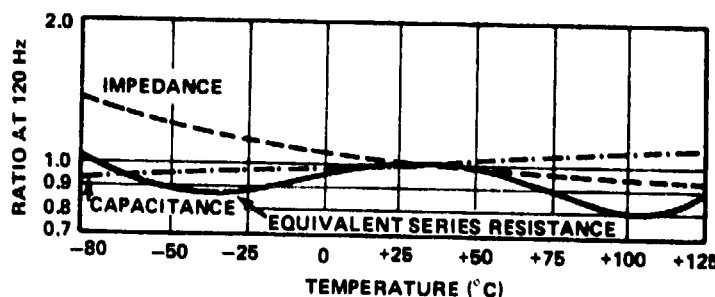

Figure 11. Typical curves of impedance, capacitance, and ESR versus temperature for 6.8  $\mu\text{F}$ , 35 V capacitors.

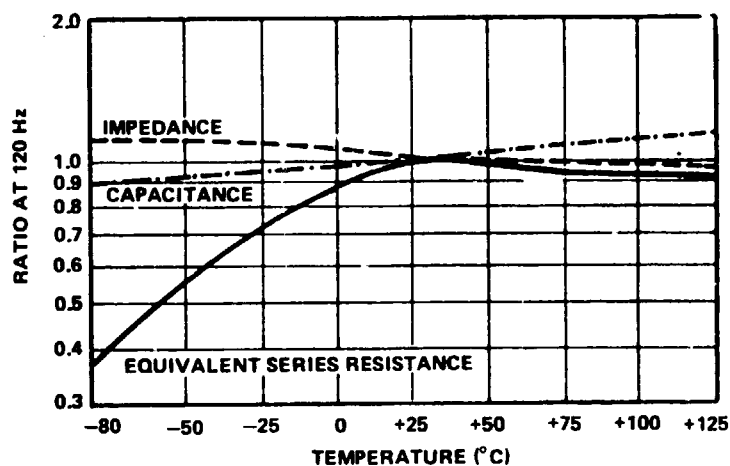
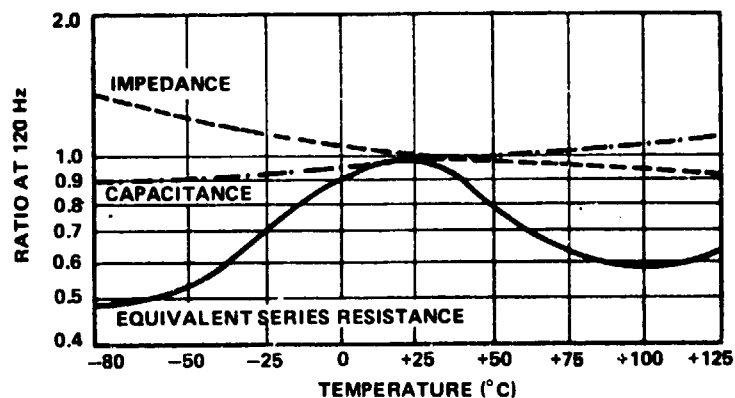

Figure 12. Typical curves of impedance, capacitance, and ESR versus temperature for 47  $\mu\text{F}$ , 35 V capacitors.



2. DC Leakage. Unfortunately, higher temperatures cause dc leakage to increase rapidly; consequently, its value may be fifty times as much at 125 $^{\circ}\text{C}$  as it is at room ambient. These values vary from capacitor to capacitor and depend upon the integrity of the  $\text{Ta}_2\text{O}_5$ . Not only is this true, but dielectric puncture and catastrophic failure are much more likely to occur at elevated temperatures. The engineer may largely circumvent these problems by derating the steady-state dc voltage (Paragraph II, F).

#### D. Permissible ac Voltage and Current

It is recommended that the applications engineer determine the peak and steady-state ac voltage and current which the capacitor in each application will experience and select from the following curves a capacitor which meets the requirements.



## Rationale

The solid tantalum capacitor is essentially a dc device and is not as well suited to handling ac as are the wet types. Applications in which the capacitor is subjected to repetitive charge/discharge cycles (especially where the source impedance is low) can produce severe stress on the dielectric. Energy storage and pulse forming applications often fall into this category, as do filter networks in which the superimposed ac ripple may be excessive. Figures 13 through 18 can serve as guidelines in these applications.

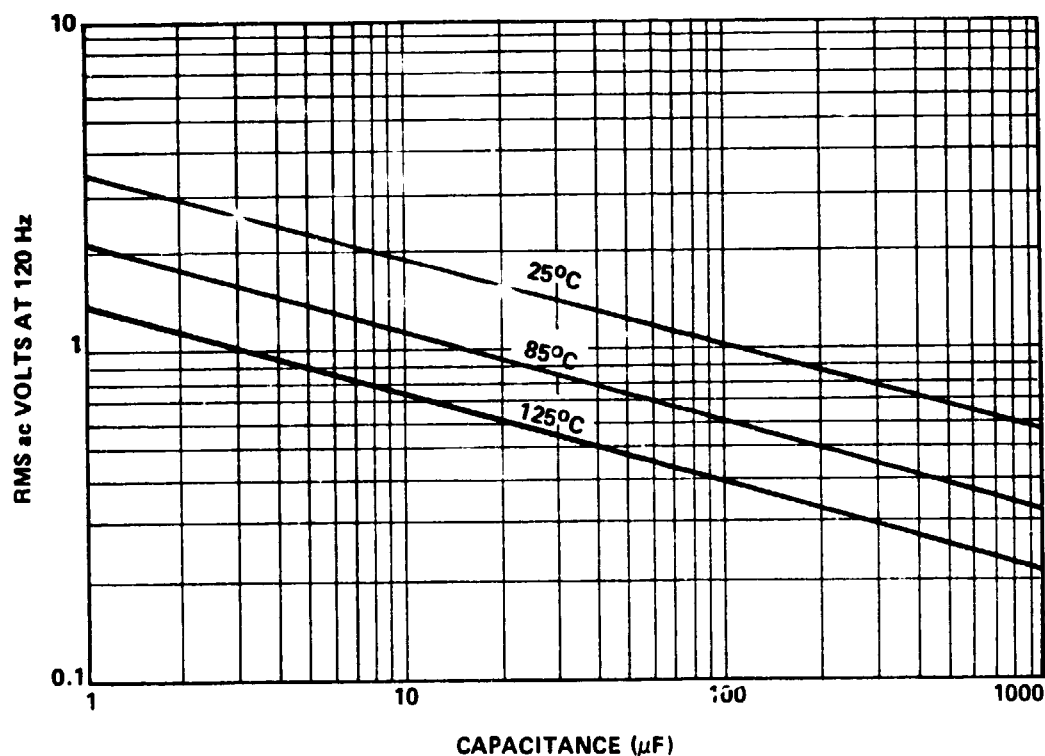

Figure 13. Permissible ripple voltage versus capacitance and ambient temperature at 120 Hz (style CSR13).

As previously stated, the reason that the capacitor can carry more ac ripple current at high frequency is because the ESR is less, and therefore  $I^2R$  loss is less. However, a small capacitor is proportionately a better heat sink per microfarad-volt than is a larger capacitor because of the relatively great surface area exposed to the ambient.

In all cases, the guidelines for limiting ac ripple previously stated in Paragraph I.D item 17 must be met.

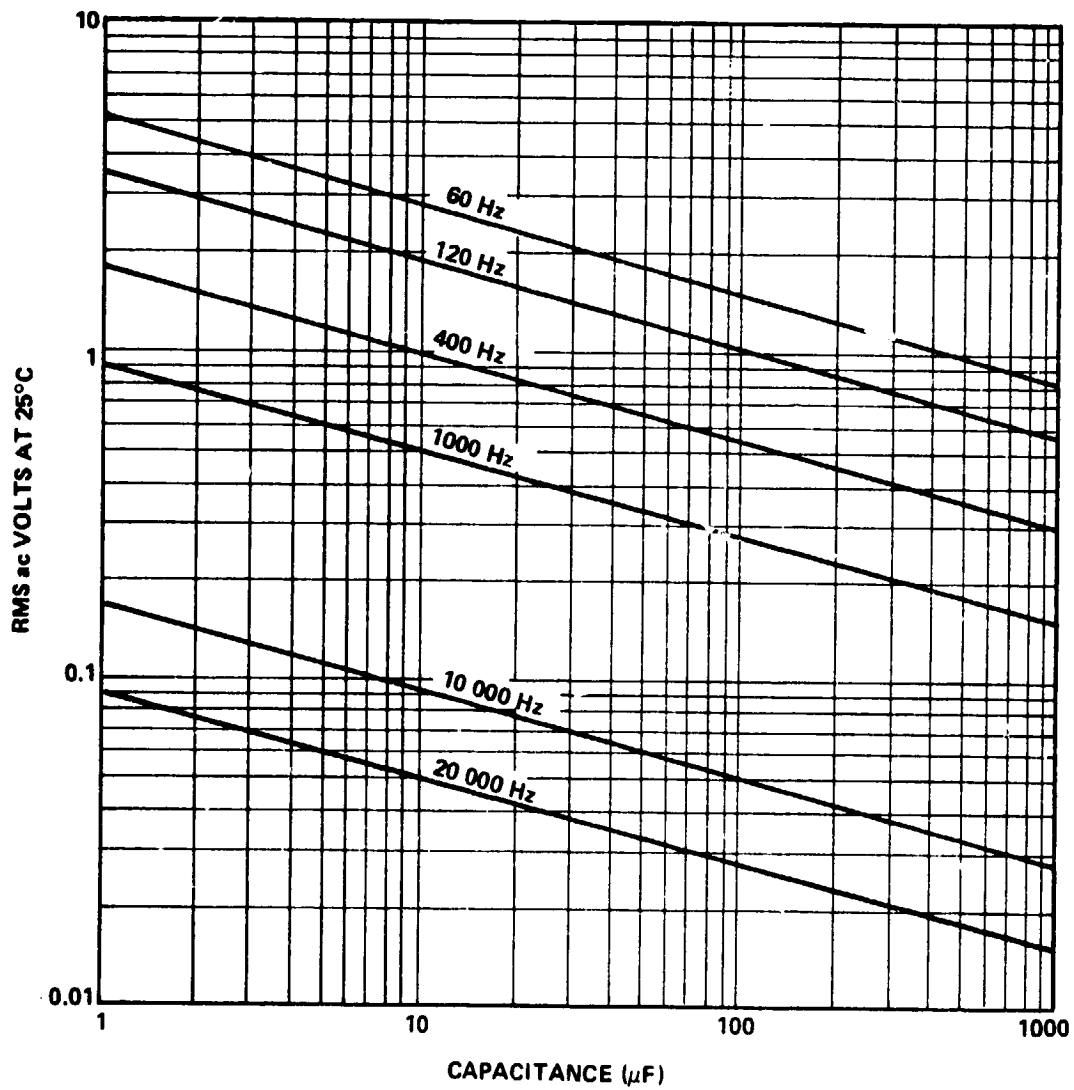

Figure 14. Permissible ripple voltage versus capacitance and frequency at 25°C (style CSR13).

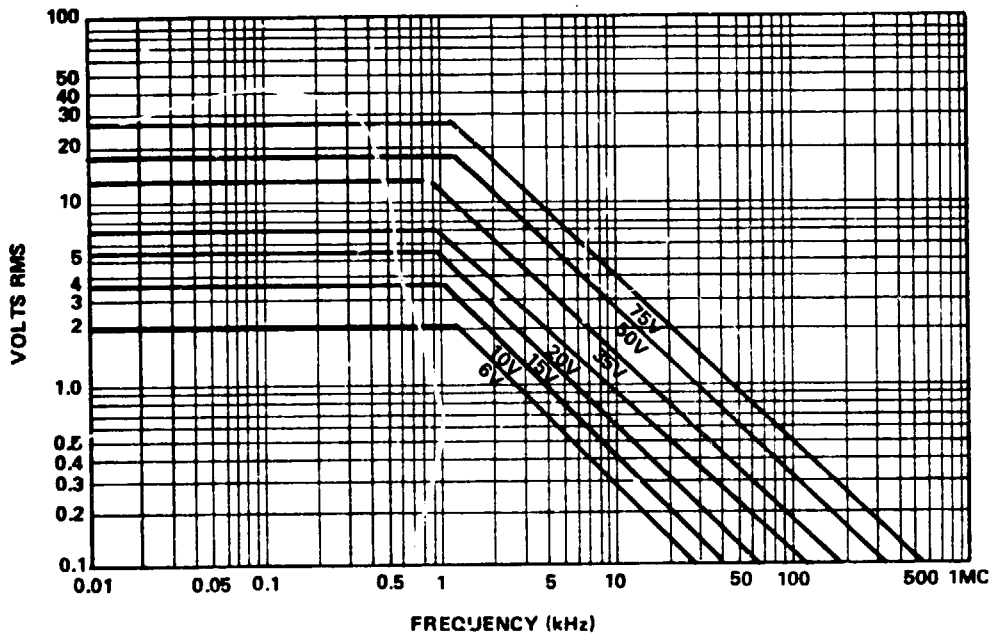

Figure 15. Maximum permissible ripple voltage as a function of frequency for case size A (style CSR13).

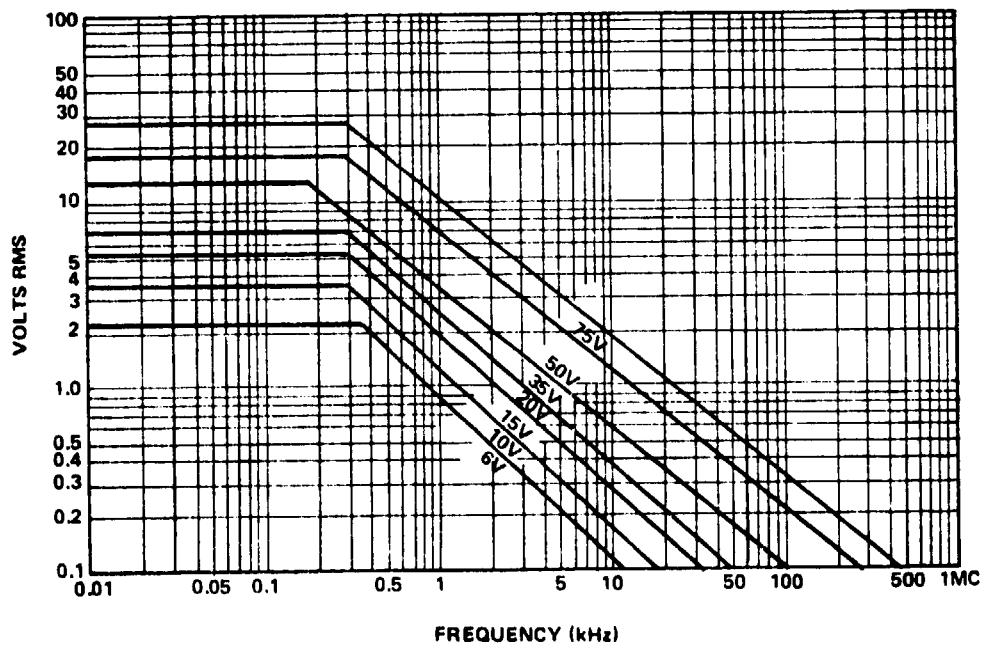

Figure 16. Maximum permissible ripple voltage as a function of frequency for case size B (style CSR13).

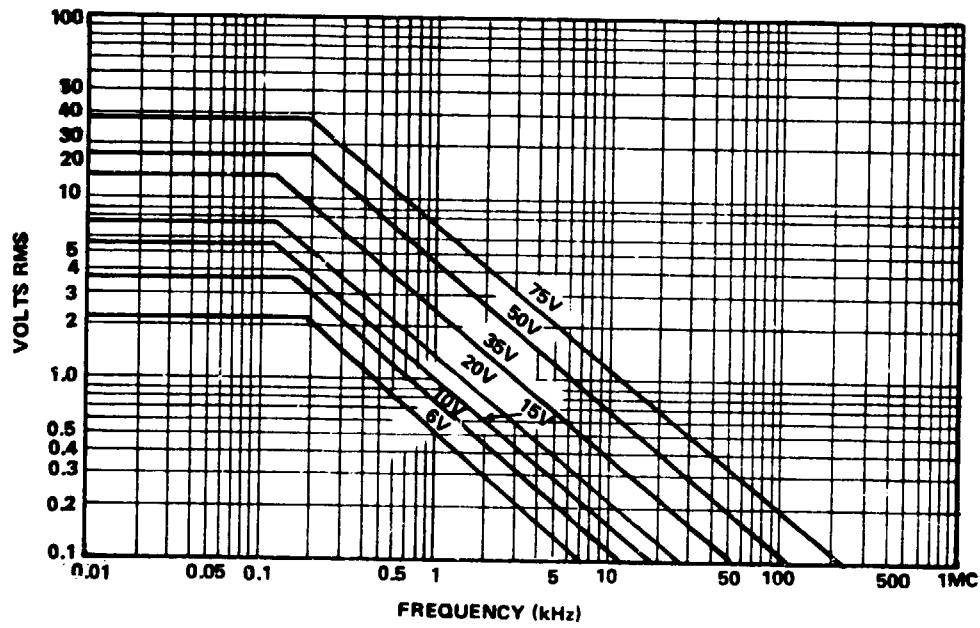

Figure 17. Maximum permissible ripple voltage as a function of frequency for case size C (style CSR13).

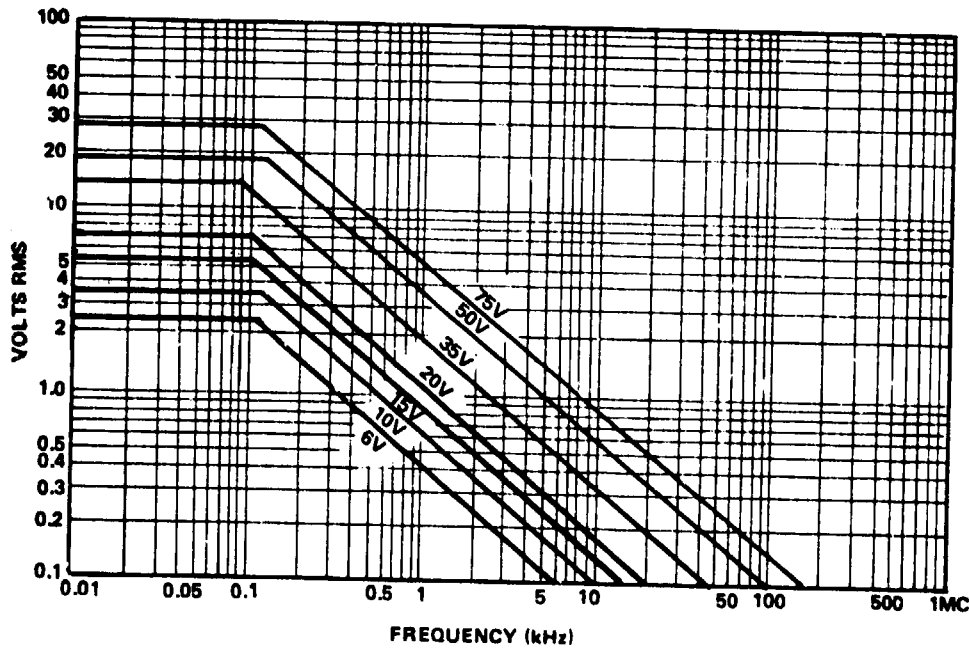

Figure 18. Maximum permissible ripple voltage as a function of frequency for case size D (style CSR13).

## E. Temperature Rise Limitation Due to ac Ripple

Temperature rise due to self-heating should be limited to 5°C. It is further recommended that when capacitors must be operated at conditions outside the MIL-SPEC recommendations, the temperature rise be measured in the actual application.

### Rationale

The rate of degradation is a function of temperature. The maximum rise of 5°C above the ambient has been chosen as an economic compromise. Heating is the result of  $I^2R$  losses, where the current component (I) is from repetitive charge-discharge cycles or ac ripple voltages and is, therefore, a function of the waveform (Paragraph I. F item 17); and the resistance component (R) is the ESR, which decreases with increasing frequency. Cooling is a function of case size and conduction and convection paths. Generally, convection paths are not available in space applications.

## F. Dielectric Protection

It is recommended that the solid tantalum capacitor not be used in applications in which a high inrush of current can occur (such as in the input capacitor of power supply filters) and that necessary measures be taken to protect the dielectric from puncture or other deterioration.

### Rationale

Every electronic part seems to have an "Achilles heel." For the solid tantalum capacitor, the paramount problem is that its dielectric is prone to deterioration and even puncture during "turn-on" or high inrush of current. Unlike the wet types, the solid is especially susceptible to failure due to high dc leakage or shorts due to dielectric deterioration caused by current surges.

The primary failure mode is a catastrophic short due to dielectric puncture. The failures are somewhat unpredictable with respect to both steady-state voltage and spikes (particularly the latter). A discussion of three steps which can alleviate this problem is given in the following paragraphs.

1. Select Appropriate Capacitor. Select capacitors which are rated under 75 Vdc because the  $Ta_2O_5$  dielectric is "formed" electrolytically on the tantalum at 2 to 4 times rated voltage to give added protection to it during pyrolysis of the  $Mn(NO_3)_2$  to produce the  $MnO_2$  coat. There is a limit to the forming voltage of any metal before scintillations occur. When tantalum is formed in phosphoric acid, as it usually is, these scintillations begin to appear above approximately 250 V, depending on temperature, concentration of the acid, purity of tantalum powder in the slug, current density, etc. Thus, since each scintillation creates an irreversible malignancy in the dielectric, care should be exercised to prevent it. For these reasons, slugs formed above 250 V (and rated above 75 V) should not be used in space hardware.

2. Derate Voltage and Temperature. Applied voltage should not exceed 60 percent of the rated voltage at 85°C and 125°C. As an example, for a capacitor rated at 75 Vdc (the highest voltage recommended), the maximum applied voltage should be 45 Vdc up to 85°C and 30 Vdc from 85°C to 125°C. If higher voltages are required for a particular application, the use of a foil or wet slug capacitor is recommended.

This derating achieves three desirable ends. First, it automatically lowers the limit on ac ripple; second, it decreases the steady-state stress on the dielectric; and third, it makes puncture due to spikes less likely. If the dielectric were perfectly homogeneous, derating would be less urgent. But, it should be understood that when pyrolysis of  $Mn(NO_3)_2$  occurs, quite corrosive oxides of nitrogen are produced, and these gases weaken the dielectric in spots at 250°C. These pinpoint defects are not entirely removed when the slugs are "rehealed" in electrolyte after pyrolysis. Scintillations may occur at these points during subsequent processing or in use. To aggravate this situation is the fact that  $MnO_2$  is a semiconductor, and is less forgiving of spikes and higher voltages than are the wet electrolytes, especially at higher temperatures. Figures 19 and 20 show how dc leakage and failure rate increase greatly as temperature and voltage increase. Temperature has a profound effect on dc leakage and failure rate as shown in Figures 19 and 20. Insofar as possible, means should be used to operate the capacitor at moderate temperatures. This may mean heat sinking, cooling by forced air, distribution of parts on the PC board to avoid proximity to hot devices such as power transistors, careful control of ac ripple levels, and related measures.

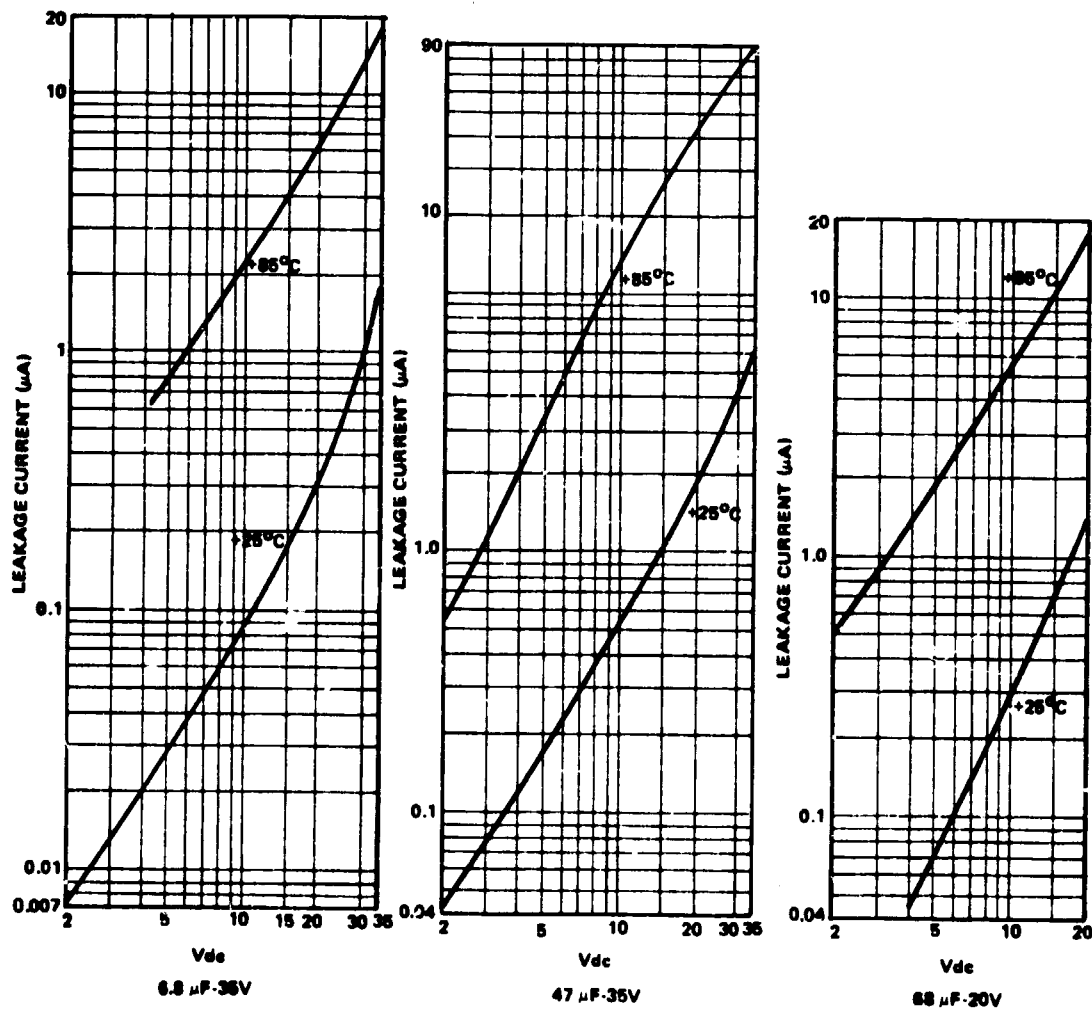

Figure 19. DC leakage current versus applied voltage for solid tantalum capacitor.

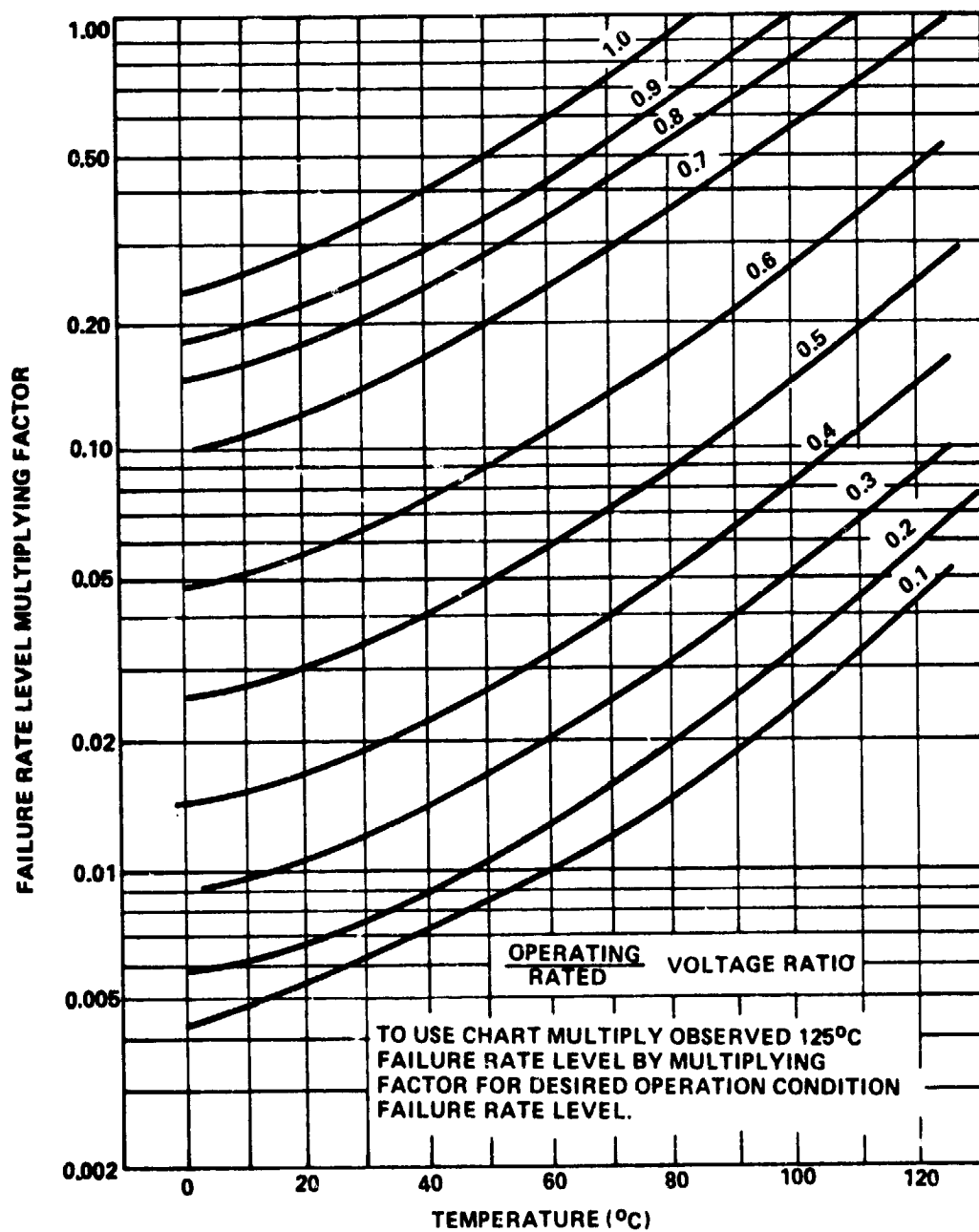

Figure 20. Failure rate versus temperature.



3. Provide Spike Protection. Special attention should be given to protecting these capacitors against spikes. This problem is especially serious during switch-on of loads and for capacitor lots not surge current screened for early failure.

The LC voltage overshoot typically lasts less than 0.5 ms, may reach 50 percent above steady-state voltage, and may approach twice the steady-state voltage with low series impedance. Solid tantalums are so susceptible to dielectric puncture due to this overshoot voltage that they should be used in such applications only when low temperature stability considerations require it, and then with adequate protection and derating. Conservative design suggests that we assume an infinite current source at turn-on, and that the overshoot voltage at turn-on be no more than 80 percent of the rated working voltage of the capacitor at the respective temperature, using sine wave. Rated working voltage may be in either the forward or reverse direction. Series impedance, voltage derating, or both may be used to achieve spike protection. If the capacitor has been idle for some time, the dipoles in the dielectric are randomly oriented. They have finite relaxation moments and orientation moments. Therefore, when the voltage is suddenly applied across the dielectric, the defects in it become particularly vulnerable to rupture. This becomes even more likely if the  $dV/dt$  or  $dI/dt$  is high; i. e., the wavefront is steep. While experimental data are scarce to quantify the failure rate with respect to waveform, voltage level, and duration, it is advised that if the wavefront is steeper than a sine wave, or if the duration of the spike exceeds 0.5 ms, the voltage overshoot should proportionately be less than the 80 percent rating recommended for the sine wave. As Figure 21 shows, this derating should be greater at 125°C.

The applications engineer should make an oscillogram of the circuit where the capacitor is located and then apply the curves for protection.

Another approach to protect the solid tantalum capacitor from spikes is to provide series impedance. A series resistor helps to attenuate spikes as well as to limit current in case of dielectric puncture. Thin or weak spots sometimes exist in the  $Ta_2O_5$  dielectric.  $MnO_2$  is deposited on the  $Ta_2O_5$  to serve as the second capacitor plate. If, when a voltage punctures the  $Ta_2O_5$ , the current flow and resultant heat are limited, the semiconductor  $MnO_2$  may be changed to  $Mn_2O_3$ . Since  $Mn_2O_3$  is a fair insulator, the capacitor is partially self-healing. However, if the current is not limited, the amorphous  $Ta_2O_5$  may overheat at a point defect, change to a crystalline conductor, and form a high leakage path or a permanent short. Most manufacturers perform a voltage conditioning

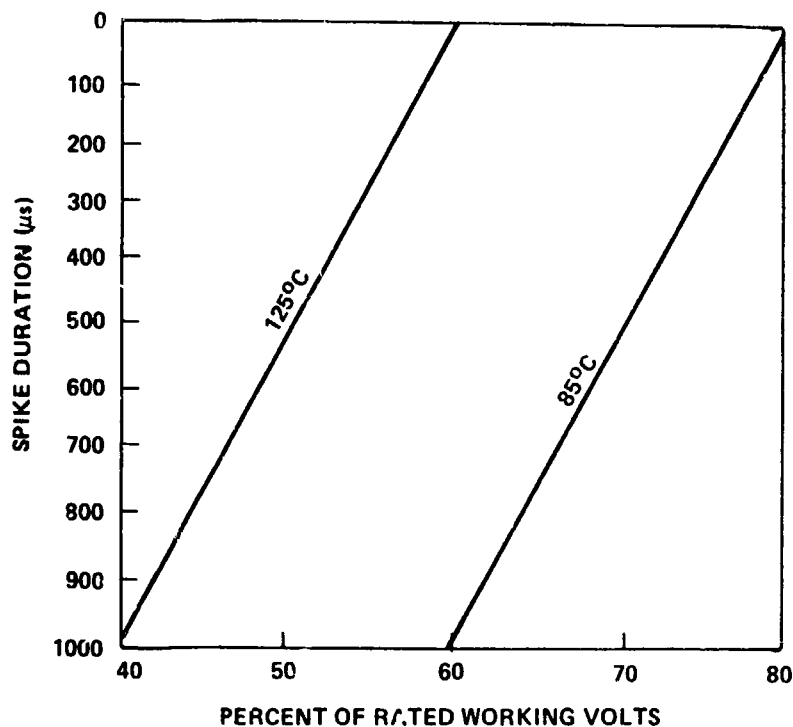

Figure 21. Maximum recommended voltage spikes for solid tantalum capacitors.

screen to detect and remove marginal capacitors. Reliability studies show that there are more failures for surviving capacitors, when the burn-in circuit is current limited and self-healing takes place, than for capacitors surviving burn-in on a circuit delivering 10 A or more to "blow" the marginal capacitors. The probability of inducing further defects, or aggravating those already present, is increased as the spike voltage and duration increase.

While solid tantalums are not recommended for circuits which produce spikes, if for some reason these capacitors must be used, adequate series impedance should be used, especially if the capacitors have not been surge current screened. A series impedance of 3  $\Omega$ /V (steady-state) up to 30 V, and 6  $\Omega$ /V above 30 V is recommended in such cases. Since design engineers are usually reluctant to use such series impedances in filter circuits, this recommendation suggests that filter capacitors be of the wet types rather than solid tantalum.

## G. Self-Generated EMF

Maximum values of self-generated EMF should be determined for various types of capacitor at elevated temperatures.

### Rationale

A solid tantalum capacitor has the following material interfaces: tantalum,  $Ta_2O_5$ ,  $Mn_2O_3$ , carbon, silver, solder, and plated steel or brass can. With this series of different materials, there will be galvanic couples that can generate voltages. These voltages may result in a self-generated voltage at the terminals, sometimes as high as 1 V. In high impedance circuits, such as vacuum tube grids, these voltages may interfere with proper circuit performance.

## H. Reverse Bias

It is recommended that peak reverse bias be limited to 15 percent of the derated forward voltage at 25°C operating ambient, 10 percent at 55°C, and 5 percent at 85°C.

### Rationale

It has been found experimentally that the dielectric can withstand these reverse voltages at these temperatures. Above these voltages the dielectric may rupture.

### III. WET FOIL TANTALUM CAPACITORS

The following recommendations and comments apply to wet foil tantalum capacitors, types CLR25, 27, 35, and 37 (Fig. 22)

#### A. Construction

Figure 22 shows the construction features of a wet foil tantalum capacitor.

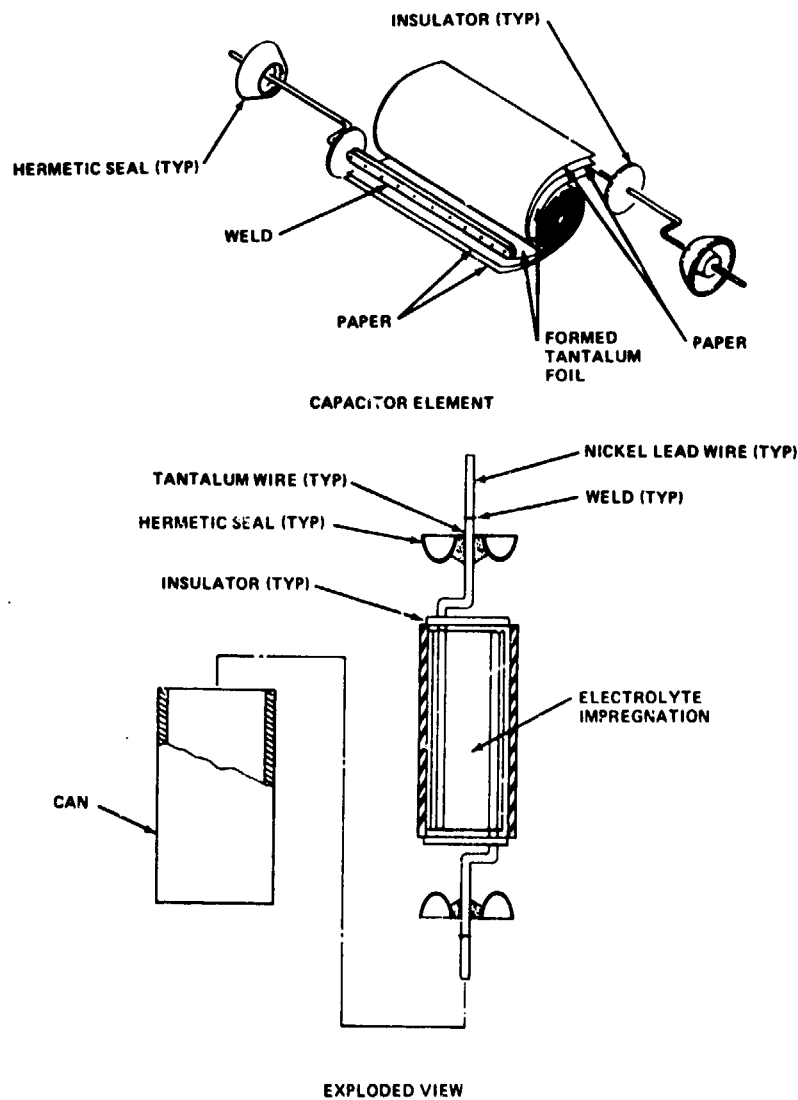

Figure 22. Construction features — wet foil tantalum capacitor.

## B. Applications at Different Frequencies and Temperatures

It is recommended that the design engineer determine the acceptable changes in electrical parameters for a given application and, after studying the following curves, select a capacitor that best meets the requirements at specified frequencies and temperatures.

### Rationale

Foil type capacitors undergo considerable change in parameters as frequency and temperature change. The engineer should remember that capacitance values are measured at 120 Hz.

1. Capacitance. Figure 23 shows the effect of frequency on capacitance of typical foil type tantalum capacitors at 25°C.

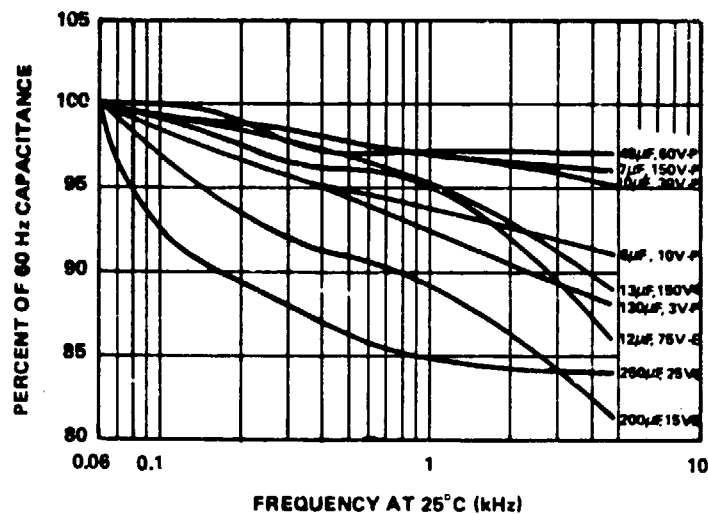

Figure 23. Effect of frequency on capacitance of typical foil type tantalum capacitors at 25°C.

2. Impedance. Figure 24 shows change of impedance with frequency for various capacitance values over the range from 60 Hz to 100 MHz. The trough occurs in the 10 to 500 kHz range, with an inductive increase in impedance at

the higher frequencies. Figures 25 through 28 illustrate size and temperature correction factors to be applied to the impedance value obtained from Figure 24. Since ESR increases significantly at low temperatures, these correction factors must be taken into consideration in design. Note that impedance at  $-55^{\circ}\text{C}$  at a given frequency may be several times the  $25^{\circ}\text{C}$  value. In general, one can say that foil types change more in electrical parameters as frequency and temperature change than do slug types. This is due primarily to the less conductive electrolytes used and to the inductive effects of the foil winding. For example, capacitance change with temperature is positive and ranges from  $-20$  to  $-40$  percent at  $-55^{\circ}\text{C}$  to an increase of  $10$  to  $50$  percent at  $125^{\circ}\text{C}$ .

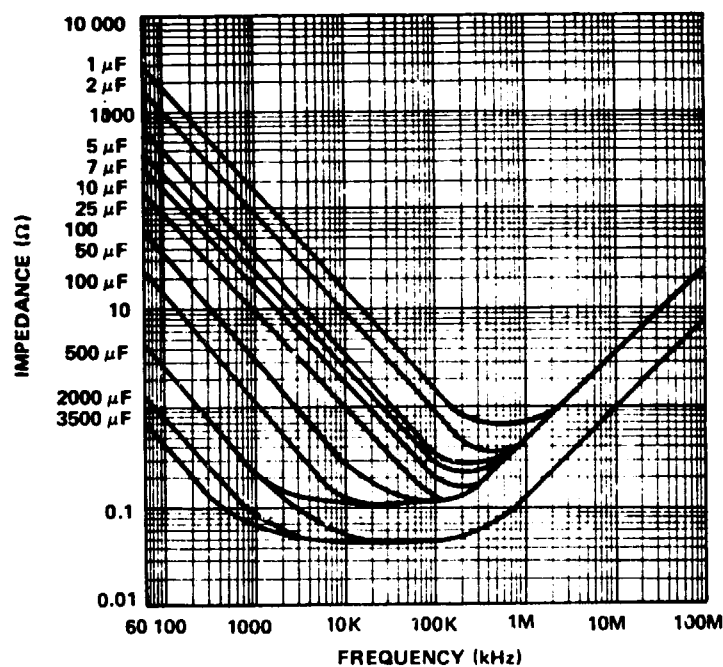

Figure 24. Impedance curves for tantalum foil capacitors at  $25^{\circ}\text{C}$ .

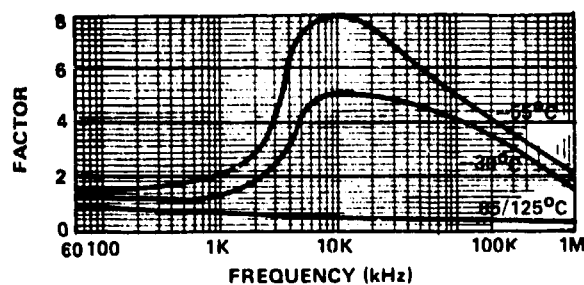

Figure 25. Tantalum foil impedance correction factors for capacitance up to  $2\ \mu\text{F}$ .

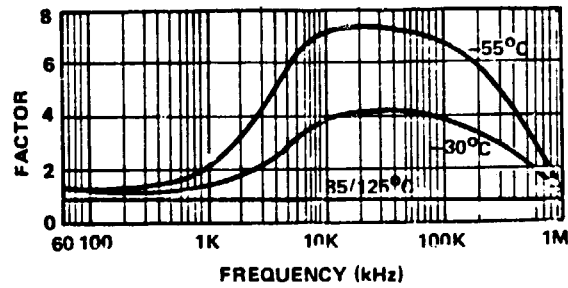

Figure 26. Tantalum foil impedance correction factors for capacitance of 2 to 50  $\mu$ F.

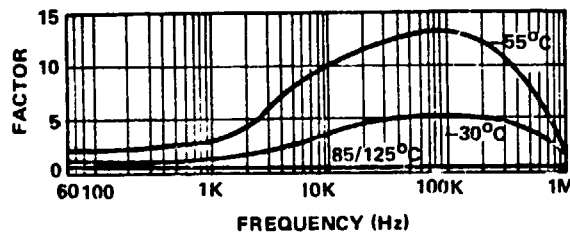

Figure 27. Tantalum foil impedance correction factors for capacitance of 50  $\mu$ F and over.

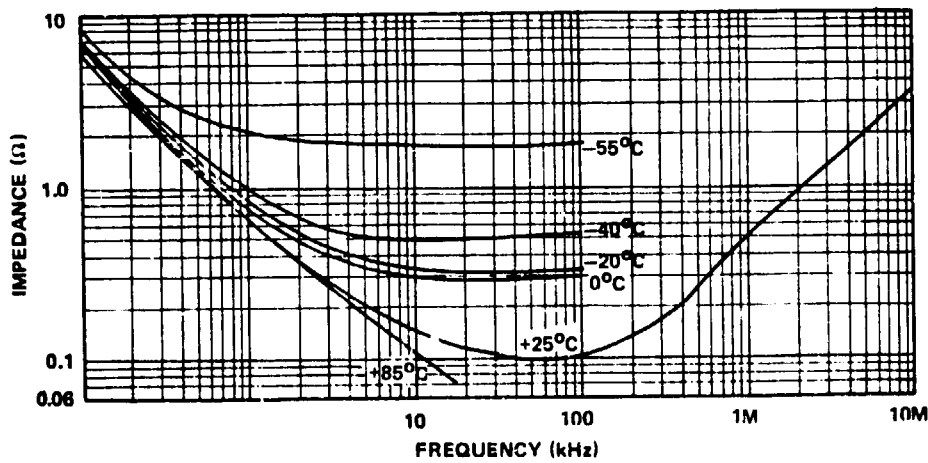

Figure 28. Typical curves of impedance with frequency at various temperatures for 200  $\mu$ F, 6 V plain foil capacitors.

3. Equivalent Series Resistance. As shown in Figure 29, ESR increases rapidly at temperatures below 0°C. This naturally affects impedance, DF, and capacitance.

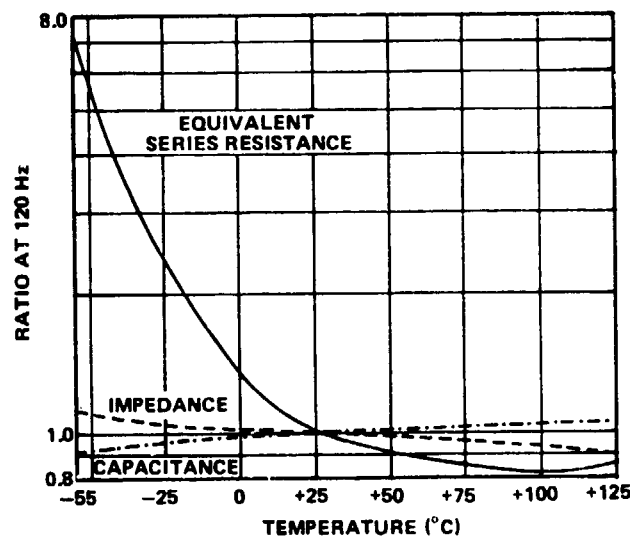

Figure 29. Typical curves of impedance, capacitance, and ESR with temperature for 26  $\mu$ F, 100 V polarized etched foil capacitors.

4. Dissipation Factor. DF increases rapidly with frequency, especially for the higher capacitance values, mainly because of the time decrease in capacitive reactance relative to the more constant value of ESR. Figure 30 depicts these DF changes.

5. DC Leakage. Leakage current of foil tantalums is in the microampere category and ranges from less than 1 to 100  $\mu$ A or more, depending on electrical rating, type of construction, and temperature.

Leakage current, as in all tantalum types, is the result of minute faults in the dielectric film. These faults tend to be self-healing under applied voltage; consequently, leakage current will normally decrease exponentially with life.

Leakage current is roughly proportional to applied voltage up to the maximum dc voltage rating.



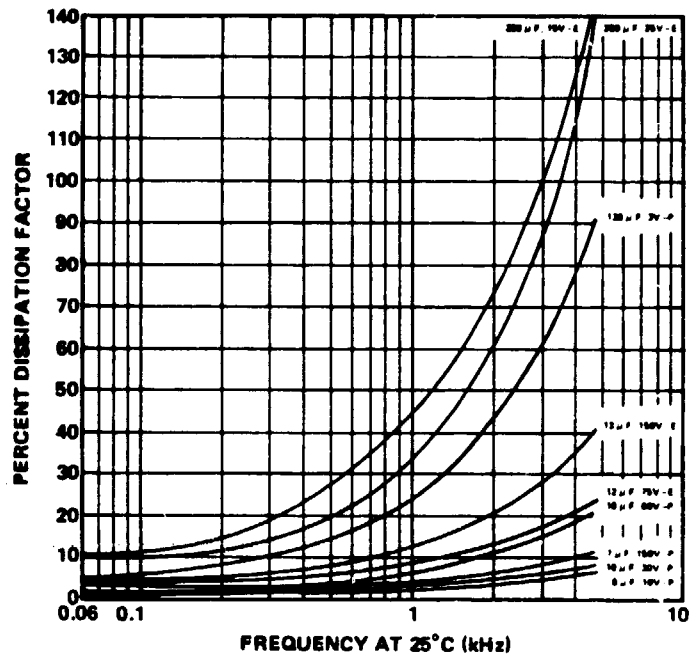

Figure 30. Effect of frequency on dissipation factor of foil type tantalum capacitors.

Leakage current increases rapidly with temperature as shown in Figure 31. Note that leakage at 125°C is approximately 30 times the room temperature value. In general, dc leakage for foil type capacitors is somewhat higher than for comparable ratings in slug types.

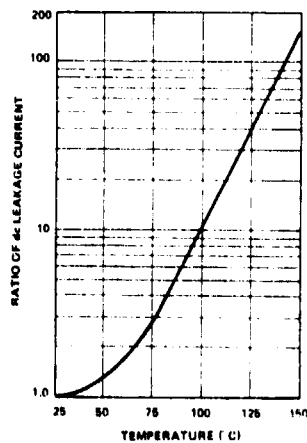

Figure 31. Typical curve of the ratio of dc leakage current at rated voltage versus temperature for foil tantalum capacitors.

### C. Permissible ac Ripple

It is recommended that the curves in Figures 32, 33, and 34 be used in selecting a foil capacitor for use in ac ripple applications.

Since foil type capacitors can be made nonpolar quite easily (thus permitting as much reverse bias as forward bias), the question often arises as to whether they may be used in ac applications without any dc bias. While test data are rather scarce for this application, it may be said in general that raw ac may be applied to these nonpolar capacitors if proper derating of voltage is followed. It is suggested that in such unusual applications the design engineer contact the vendor for advice. The engineer should provide information on waveform, temperature ranges, peak and RMS voltages and current, duty cycles, corona, etc.

### D. Temperature Rise Limitation Due to ac Ripple

Follow the same recommendations as for solid tantalums in Paragraph II. E.

### E. Dielectric Protection

It is recommended that voltage surges not exceed the rated voltage at the respective temperature, and that for critical space applications the steady-state voltage be derated to 60 percent of rated voltage at the respective temperature (as stated in Paragraph I. J).

#### Rationale

While wet type tantalums tolerate higher voltages and voltage spikes better than do the solids, they too can experience dielectric puncture. Figures 35 and 36 show that the failure rate of these capacitors is a function of applied voltage and temperature. These are typical curves. They show that the failure rate increases sharply when the applied voltage is above 70 percent of rated voltage. While the increasing failure rate with temperature shown in Figure 36 may be attributed to loss of electrolyte in non-hermetically sealed capacitors, causing degradation of electrical parameters, it is a well known fact that elevated temperatures degrade the dielectric ( $Ta_2O_5$ ) and may cause high dc leakage or eventual dielectric rupture and shorts.

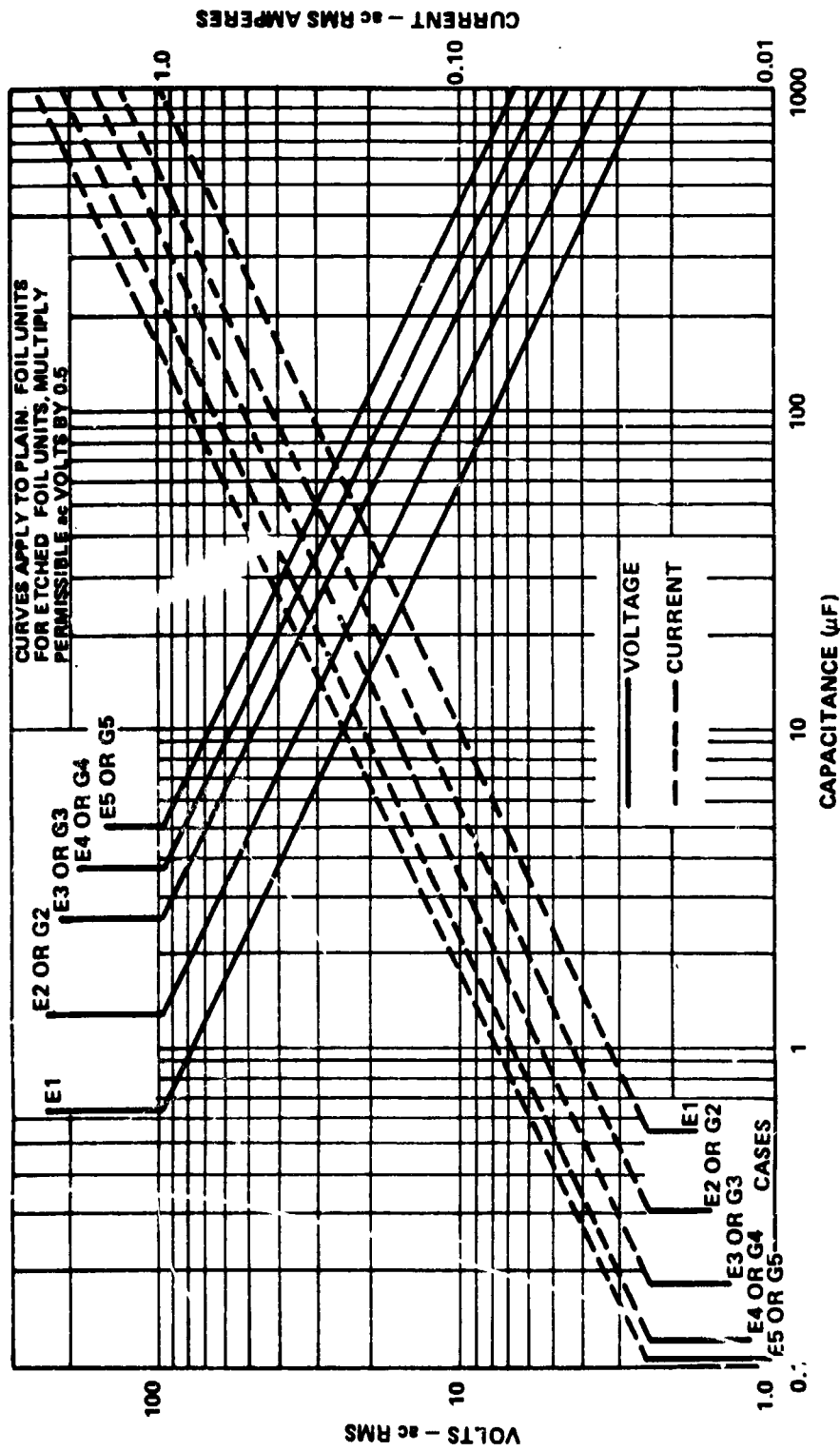

Figure 32. Maximum allowable ripple voltage and current for styles CLR25, 27, 35, and 37 foil capacitors at 60 Hz.

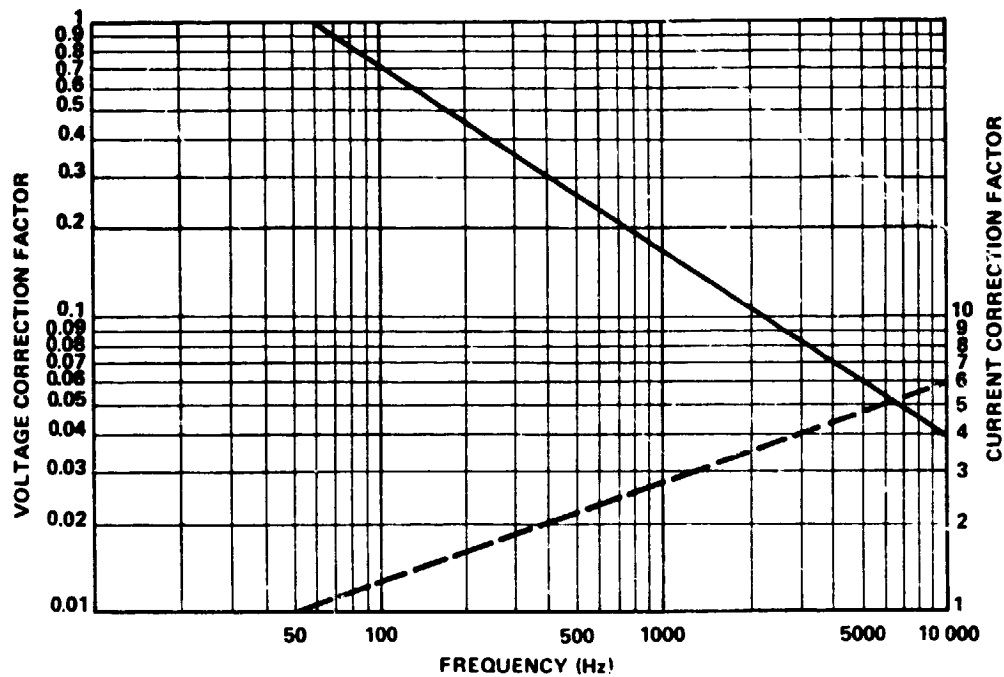

Figure 33. Correction factor for maximum allowable ripple current and voltage versus frequency for tantalum foil capacitors.

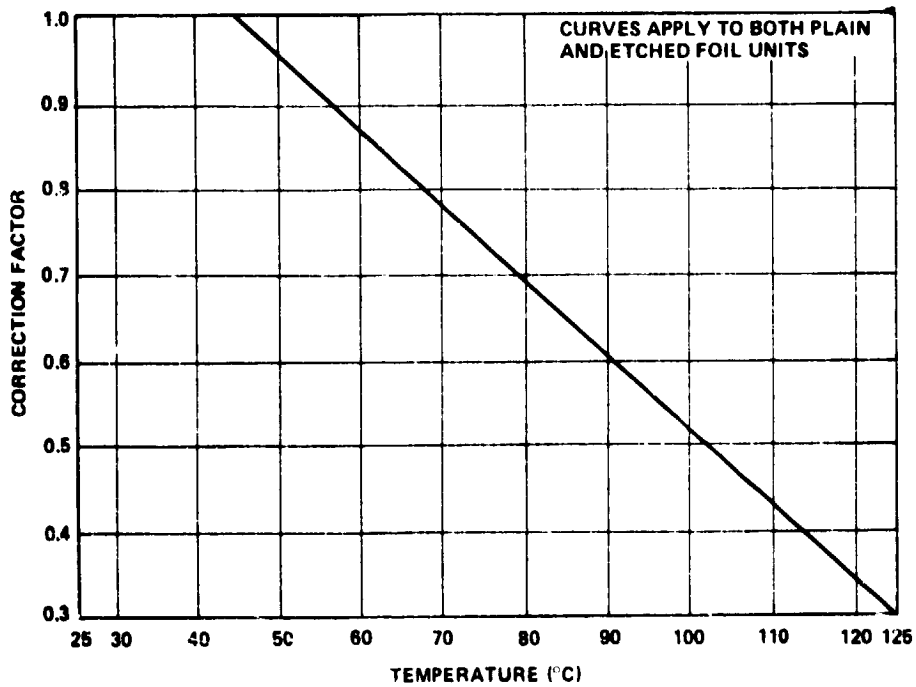

Figure 34. Correction factor for maximum allowable ripple voltage versus temperature for tantalum foil capacitors.

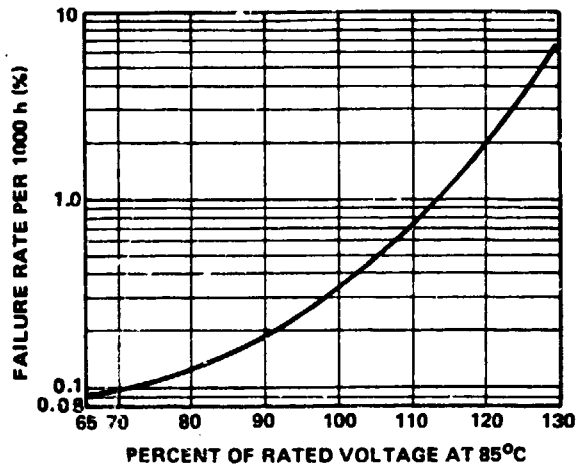

Figure 35. Typical effects of applied dc voltage on failure rate of foil capacitors.

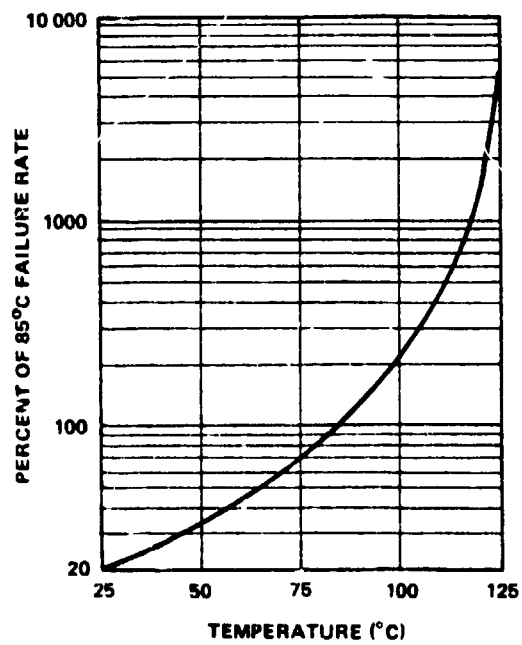

Figure 36. Typical effects of temperature on failure rate of foil capacitors.

The curves shown in Figure 37 are recommended to protect the foil type capacitors from spikes of various durations. Of course, as in the case of any dielectric, the steeper the wavefront of the spike the more likely it is to puncture the dielectric.

See Paragraph II. F. 3 for a discussion of LC voltage overshoots in switching applications.

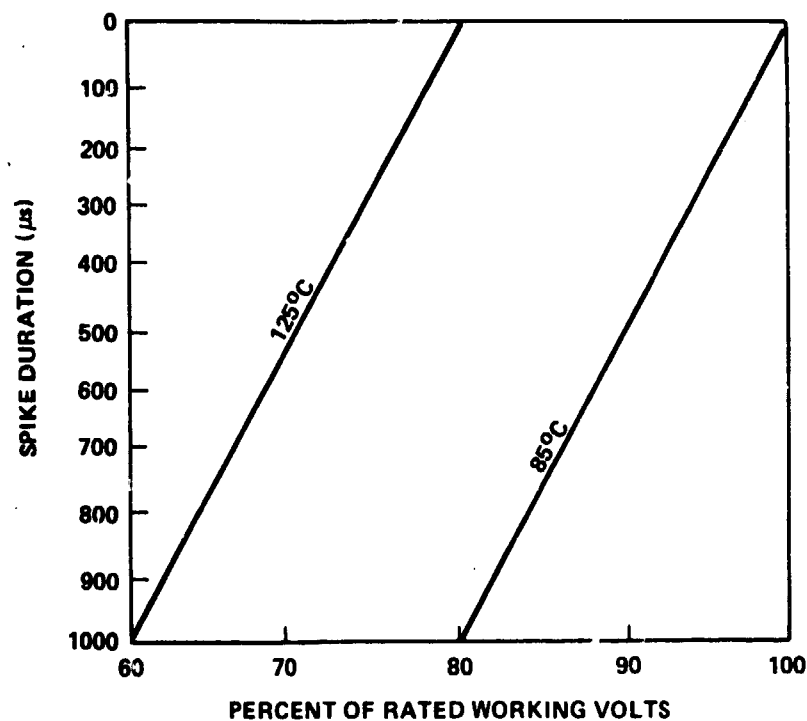

Figure 37. Maximum recommended voltage spikes for foil tantalum capacitors.

## F. Vibration Protection

It is recommended that these capacitors not be used in applications in which vibration levels exceed 65 g<sub>RMS</sub> random.

### Rationale

The windings in the capacitor case should not fit too tightly lest the foil puncture the paper separators and cause a short. Therefore, unlike the slug types in which the solid is solder encased and the wet slug is firmly held by deflon "spiders," the foil capacitor cannot tolerate high vibration because of the loose fit of the winding in the case. Capacitors can be made to tolerate higher vibration levels by using grommets in each end.

## IV. TANTALUM CASED WET SLUG TANTALUM CAPACITORS

The following recommendations apply for all tantalum cased wet slug tantalum capacitors, type CLR79 (Fig. 38).

### A. Construction

Figure 38 shows the construction features of a tantalum cased wet slug capacitor.

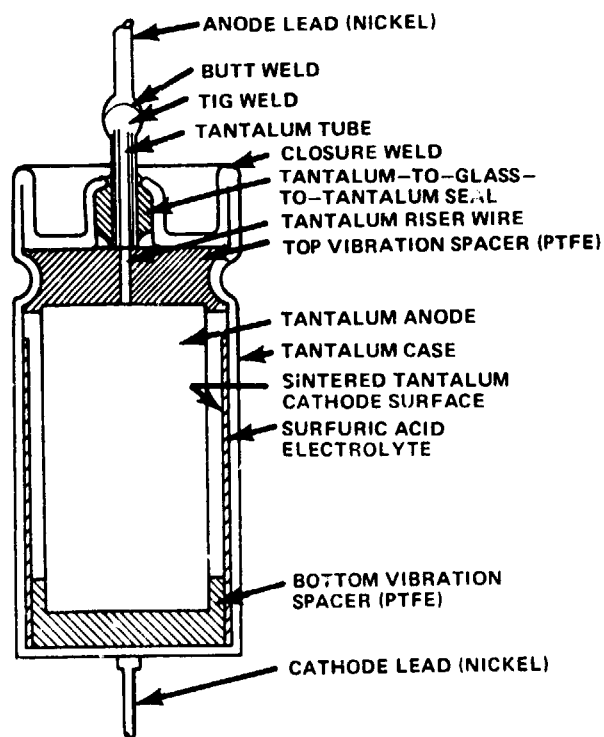

Figure 38. Construction features — tantalum cased wet slug tantalum capacitor.

This CLR79 type has been developed and qualified in the 1975-76 time frame to overcome deficiencies in the silver-cased CLR65 such as silver migration, imperfect seals, and no reverse bias capability. The tantalum cathode may be either a sintered tantalum powder liner or a powder coat sintered to (and integral with) the case.



## B. Applications at Different Frequencies and Temperatures

It is recommended that the design engineer determine the acceptable changes in electrical parameters for a given application under different frequency and temperature conditions, and select the wet slug capacitor that best meets the requirements, based on information given by the following curves.

### Rationale

Wet slug capacitors undergo some change in electrical parameters (as do the older silver-cased units) as frequency and temperature change. Generally, these changes are not as severe as for etched foil capacitors, but are slightly greater than for the solids. Again, the engineer should remember that ratings are measured at 120 Hz.

1. Capacitance. Figures 39, 40, and 41 show that capacitance values decrease at low temperatures, and that the changes are greatest with high capacitance units and least with low capacitance units. Thus, the largest case (T4) units exhibit the greatest changes.

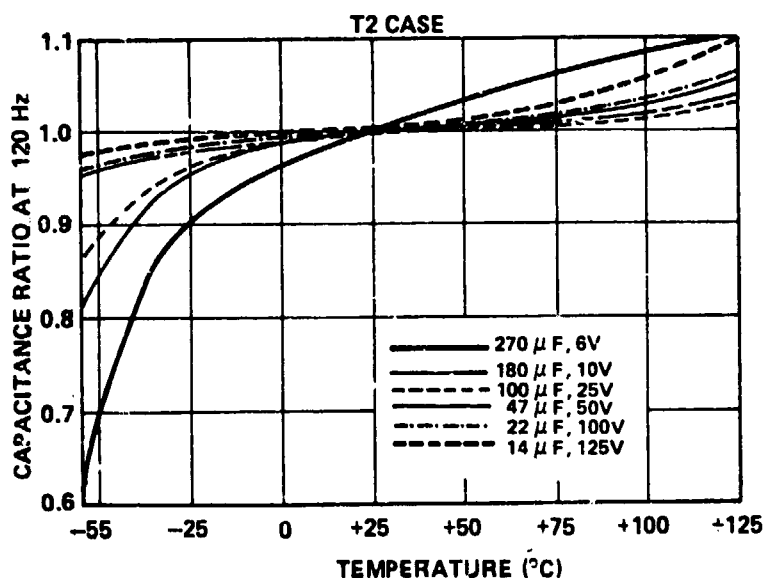

Figure 39. Effects of temperature on capacitance of CLR79 capacitors (T2 case).

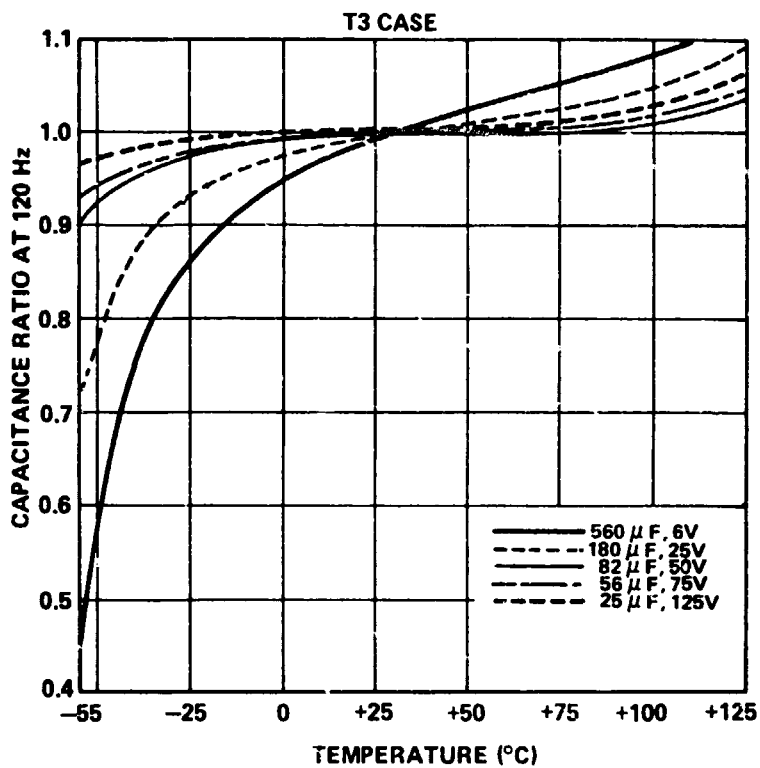

Figure 40. Effects of temperature on capacitance of CLR79 capacitors (T3 case).

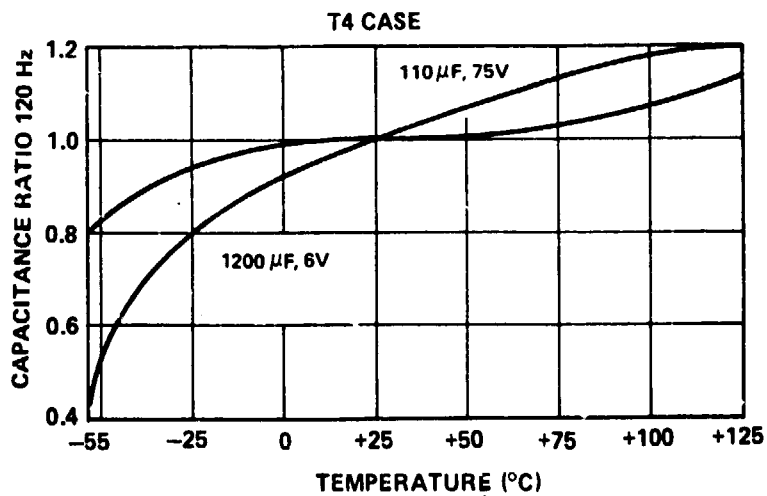

Figure 41. Effects of temperature on capacitance of CLR79 capacitors (T4 case).

2. Impedance. Figures 42 and 43 show that impedance changes with frequency- and temperature variations follow the same pattern as do those for other capacitor types; however, the wet slug types can tolerate higher frequencies with smaller changes in impedance than can the foils and about the same as for the solids.

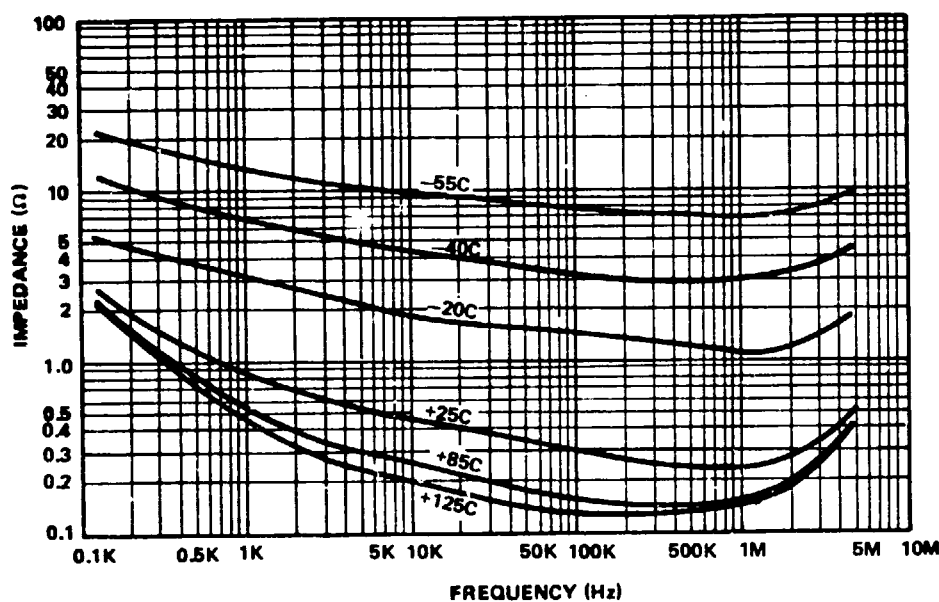

Figure 42. Typical curves of impedance with frequency at various temperatures for wet slug 560  $\mu$ F, 6 V capacitors.

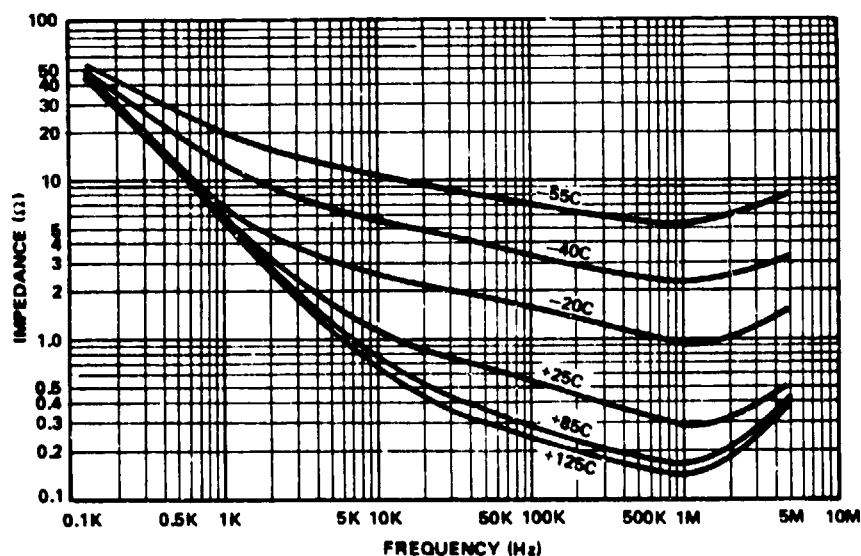

Figure 43. Typical curves of impedance with frequency at various temperatures for wet slug 25  $\mu$ F, 125 V capacitors.

3. Equivalent Series Resistance. Reduction of ESR with increase in frequency is shown in Figure 44, and decrease in ESR with higher temperatures and increase at lower temperatures is shown in Figure 45.

4. DC Leakage. Values for dc leakage are virtually the same as for the older CLR65 silver-cased types. These values increase greatly with temperature and voltage. Increases in dc leakage with temperature are similar to those shown for foil capacitors in Figure 31. Increases of dc leakage with applied dc voltage are shown in Figure 46.

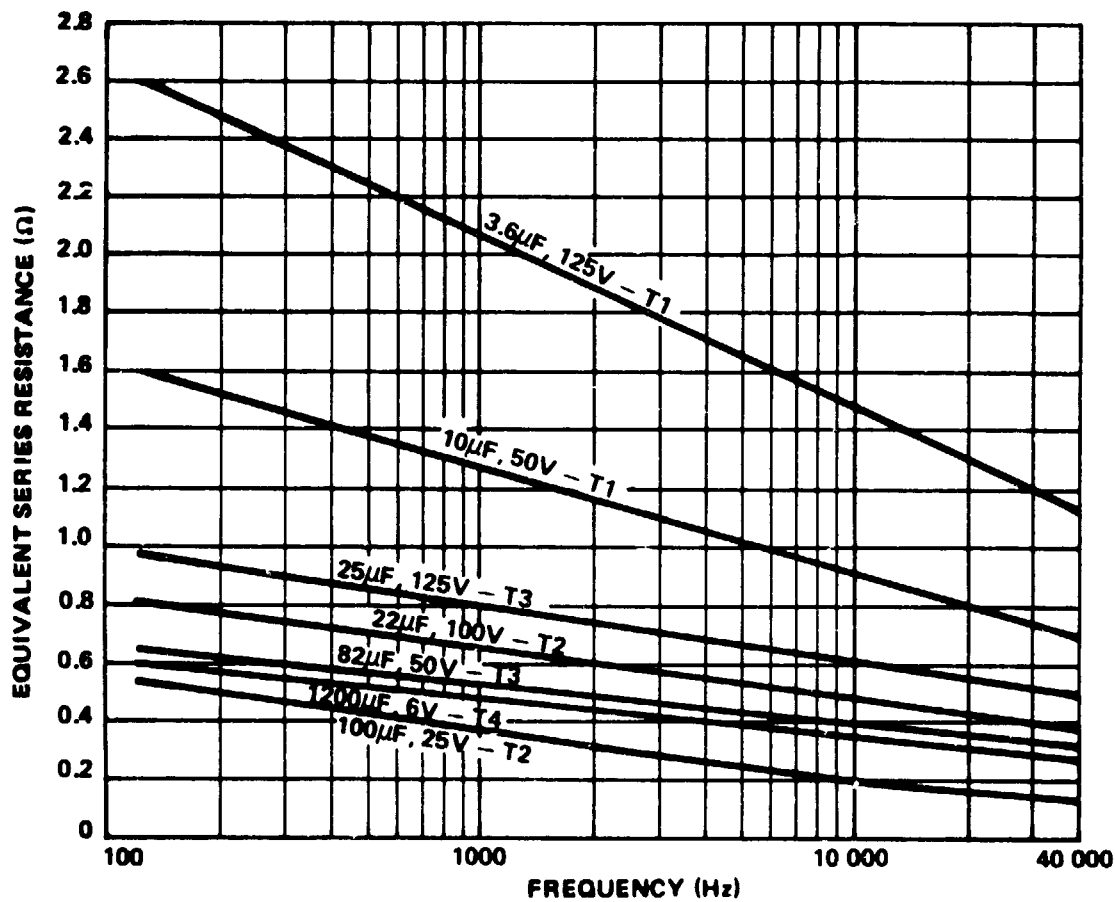

Figure 44. Effects of frequency on ESR of wet slug capacitors of various ratings.

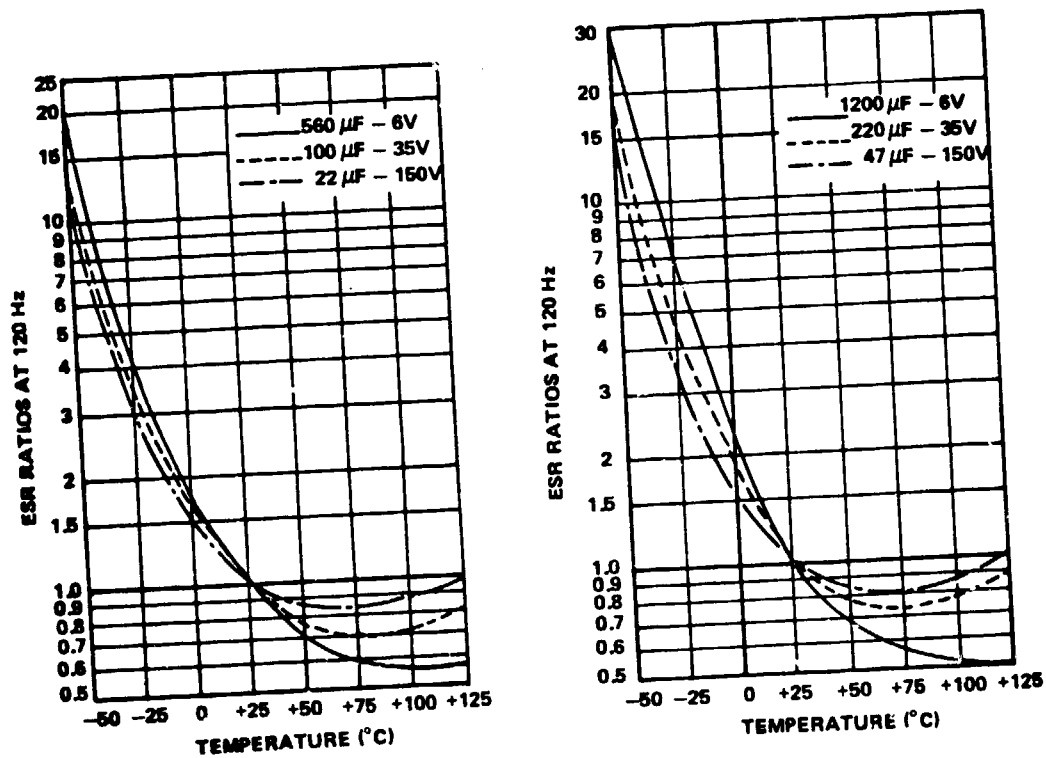

Figure 45. Typical curves of ESR as a function of temperature for capacitors of various ratings (the 150 V capacitor is not standard).

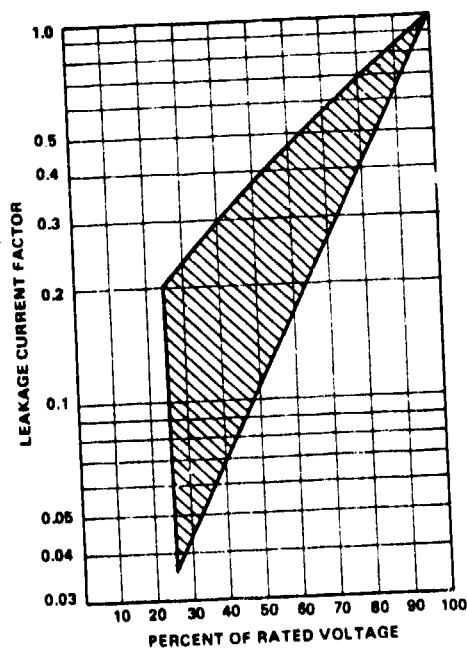

Figure 46. Effects of applied dc voltages on dc leakage of CLR79 capacitors.

### C. Permissible ac Ripple

It is recommended that the following curves be used in selecting a wet slug capacitor for ac ripple application.

#### Rationale

The all-tantalum capacitor is well adapted for use in ac applications such as filtering. Even so, the design engineer must know the frequency, temperature range, peak and RMS voltage and current, and related data to select the capacitor rating best suited to the application.

The curves shown in Figures 47 through 50 should be followed when determining the temperature rise to be expected for each case size at different ac ripple levels (120 Hz and 40 kHz, respectively) with a base temperature at ambient.

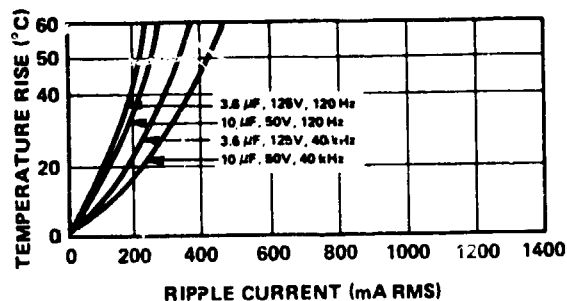

Figure 47. Typical T1 case temperature rise as a function of ripple current.

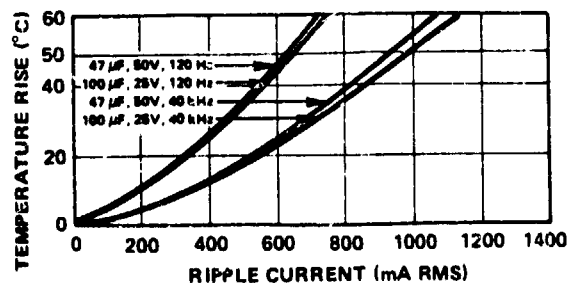

Figure 48. Typical T2 case temperature rise as a function of ripple current.

REPRODUCIBILITY OF THE ORIGINAL PAGE IS POOR

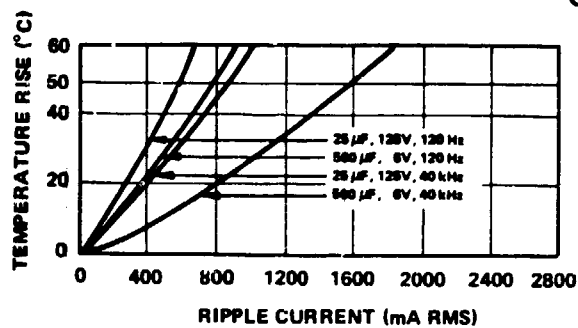

Figure 49. Typical T3 case temperature rise as a function of ripple current.

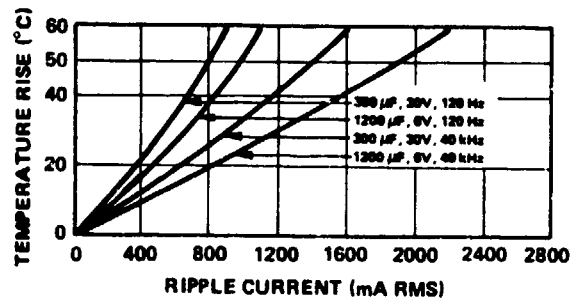

Figure 50. Typical T4 case temperature rise as a function of ripple current.

## D. Dielectric Protection

It is recommended that the spike derating curve used in Paragraph III.E for foils also be used for wet slug capacitors.

### Rationale

Although the wet slug capacitors have the best tolerance to transients and spikes, for high reliability applications they should have some protection. This in effect permits a spike to have a voltage between the full rated voltage and the 60 percent derated voltage recommended for all these capacitors.

## E. Surge Tolerance

It is recommended that these all-tantalum capacitors be used in applications where substantial voltage and current surges are used.

Rationale

Voltage and current surges are to be expected in many circuits, such as during turn-on or turn-off of power supplies. These all-tantalum capacitors do not have a silver whisker problem, they can tolerate up to 3 V reverse bias and can therefore withstand a "ringing" circuit well. Tests show that they can also tolerate surges well. The curves in Figure 51 show changes in capacitance and dc leakage after the capacitor was subjected to 100 000 surge-current cycles of 100 A, 0.5 s charge and 0.5 s discharge through a resistance of 0.3  $\Omega$  from a bank of very low ESR capacitors of 100 000  $\mu\text{F}$ . The typical value of capacitance change was 1.6 percent decrease, and the dc leakage improved.

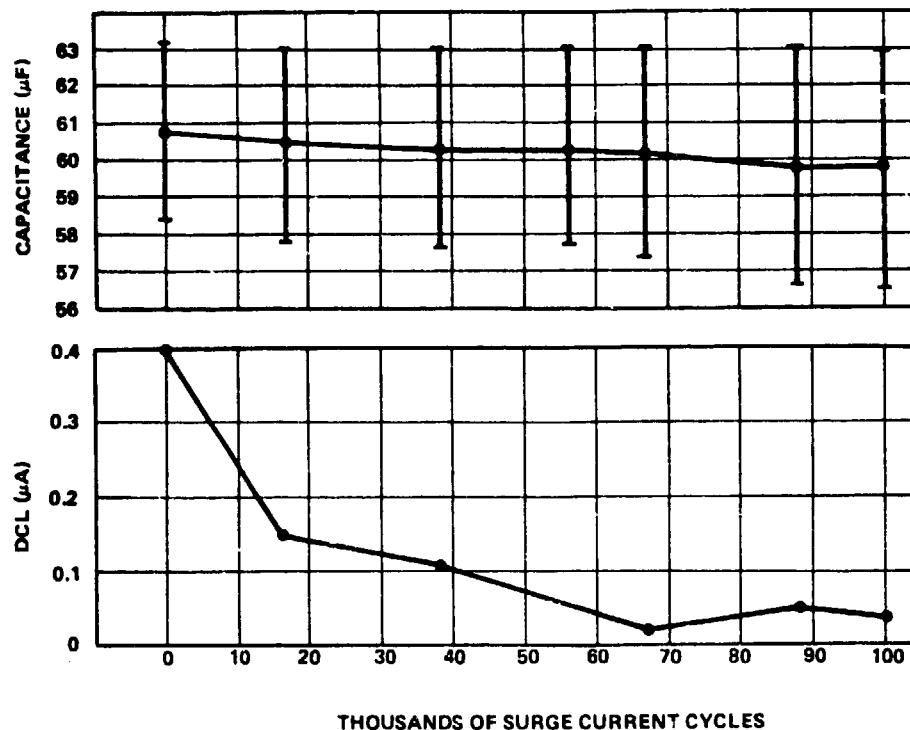

Figure 51. Effects on capacitance and dc leakage of current-surge tests on CLR79 capacitors.

F. Protection from Hydrogen Pressure

Voltage levels should be limited on these capacitors lest too much hydrogen be produced and the capacitor explode.



## Rationale

Hydrogen gas can be produced electrolytically on the anode or cathode by excessive ac ripple or dc voltage. Increases in pressure caused by heating from ripple currents will reverse when the ripple current decreases. Pressure increases due to the electrochemical liberation of hydrogen caused by the dc leakage current are cumulative. Therefore, it is desirable to know how long it will take before excessive pressure due to hydrogen accumulation is reached.

In an electrochemical system, hydrogen is produced at the cathode. The maximum amount that can be formed is limited by Faraday's law of electrolysis. The passage of 2 Faradays (96 500 C each) of charge generates 1 mole of hydrogen. From this, the amount of hydrogen generated in a given capacitor can be calculated. Additionally, the magnitude of the pressure reached is reduced because of adsorption of hydrogen by the tantalum.

Tantalum, like palladium, adsorbs gaseous hydrogen. The amount of hydrogen adsorbed decreases with increasing temperature, but in the temperature range from room temperature to 100°C, 1 gm-atom of tantalum (181 gm) will adsorb approximately 0.75 gm-atom (0.75 gm) of hydrogen. Using this information, the calculation of the amount of hydrogen that will be adsorbed by the tantalum is

$$\begin{aligned} 2 \text{ Faradays} &= 193\,000 \text{ A-s (C)} \\ &= 53.6 \text{ A-h} \\ &= 53.6 \times 10^6 \mu\text{A-h.} \end{aligned}$$

Now, 1 mole of hydrogen at 0°C and 760 mm Hg is equal to 22 400 cc by volume or 2.0 gm by weight. Therefore,  $53.6 \times 10^6 \mu\text{A-h}$  will generate 2 gm of hydrogen.

Since a T2 case-size, tantalum-cased wet slug capacitor contains 3 gm of tantalum at its cathode, then it will adsorb

$$\frac{3 \text{ gm Ta}}{181 \text{ gm Ta}} \times 0.75 \text{ gm H}_2 = 0.013 \text{ gm H}_2 \quad .$$

The amount of hydrogen generated by the dc leakage current is:

1 mole H<sub>2</sub> for 2 Faradays charge

2 gm H<sub>2</sub> for  $53.6 \times 10^6 \mu\text{A-h}$

$3.73 \times 10^{-8}$  gm H<sub>2</sub> for  $1 \mu\text{A-h}$ .

Therefore, the charge required to saturate the tantalum in a T2 case size unit with hydrogen is:

$$\begin{aligned} \frac{0.013 \text{ gm H}_2 \text{ (for saturation)}}{2.0 \text{ gm H}_2 \text{ (1 mole)}} \times 53.6 \times 10^6 \mu\text{A-h (per mole)} \\ = 0.338 \times 10^6 \mu\text{A-h (for saturation)} \\ = 38.6 \mu\text{A-years} \end{aligned}$$

Similarly, assuming tantalum weights for case sizes as follows, the charge required to saturate the tantalum with hydrogen will be:

<u>Case</u>	<u>Tantalum</u>	<u>Charge</u>
T2	3 gm	38 $\mu\text{A-years}$
T3	5.5 gm	70 $\mu\text{A-years}$
T4	6.9 gm	88 $\mu\text{A-years}$

Because of the low dc leakage current in these capacitors, there is no need to compute hydrogen pressure accumulation after adsorption is complete since this point will never be reached.

Furthermore, silver does not adsorb hydrogen nor does it react with it. There has been long and extensive experience with hermetically-sealed silver-cased units, and they have been shown to be safe. Obviously, a tantalum-case

capacitor, which has the capability of adsorbing hydrogen even at room temperature, is even less likely to have problems because of hydrogen generation. While tantalum embrittles with hydrogen, this is not a danger due to the small amounts of gas produced.

### G. Voltage Derating

The voltage applied to these capacitors shall not exceed 60 percent of the rated voltage at 85°C and 125°C, respectively. (The 125°C rated voltage is 67 percent of 85°C rated voltage.)

#### Rationale

The maximum rated voltage at 85 and 125°C is 125 and 82 V, respectively, per MIL-C-39006/22. Data tend to show that operation of these devices above 125 V with the present design using sulfuric acid electrolyte may cause dielectric deterioration.

### H. Spike Protection

Use the same curve as for foils, namely Figure 37.

APPROVAL

GUIDELINES FOR THE SELECTION AND APPLICATION  
OF TANTALUM ELECTROLYTIC CAPACITORS  
IN HIGHLY RELIABLE EQUIPMENT

By Dr. A. M. Holladay

The information in this report has been reviewed for security classification. Review of any information concerning Department of Defense or nuclear energy activities or programs has been made by the MSFC Security Classification Officer. This report, in its entirety, has been determined to be unclassified.



A. M. HOLLADAY  
Staff, Electronics Development Division

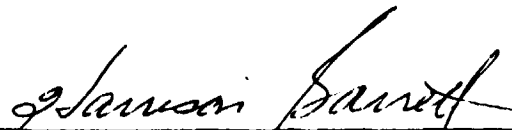

HARRISON GARRETT  
Chief, Electronics Development Division



F. BROOKS MOORE  
Director, Electronics and Control Laboratory