

NASA TECHNICAL MEMORANDUM

NASA TM-75081

PRINCIPLE CHARACTERISTICS OF THE
NATIONAL EARTH OBSERVATION SATELLITE,
PROJECT SPOT

M. Cazenave, et.al.

(NASA-TM-75081) PRINCIPLE CHARACTERISTICS
OF THE NATIONAL EARTH OBSERVATION SATELLITE.
PROJECT SPOT (National Aeronautics and Space
Administration) 36 p HC A03/MF A01 CSCL 22A

N78-18492

Unclas

G3/43 05477

Translation of "Caracteristiques Principales du Satellite National
D'Observation De La Terre, PROJECT SPOT," Centre National D'Etudes
Spaciales, Paris, France, Centre Spatial de Toulouse
Document CST/D863, 31 October 1977, pp. 1-30

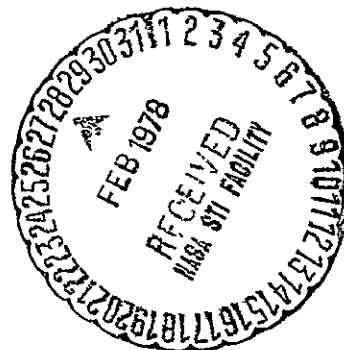

NATIONAL AERONAUTICS AND SPACE ADMINISTRATION
WASHINGTON, D.C. 20546 JANUARY 1978

1. Report No. NASA TM-75081		2. Government Accession No.		3. Recipient's Catalog No.	
4. Title and Subtitle PRINCIPLE CHARACTERISTICS OF THE NATIONAL EARTH OBSERVATION SATELLITE--PROJECT SPOT				5. Report Date January 1978	
				6. Performing Organization Code	
7. Author(s) M. Cazenave, et.al.				8. Performing Organization Report No.	
				10. Work Unit No	
9. Performing Organization Name and Address TRANSEMANANTICS, INC. 1901 Pennsylvania Ave., NW, #407 Washington, DC 20006				11. Contract or Grant No. NASW-2792	
				13. Type of Report and Period Covered Translation	
12. Sponsoring Agency Name and Address National Aeronautics and Space Administration Washington, DC 20546				14. Sponsoring Agency Code	
				15. Supplementary Notes Translation of "Caracteristiques Principles du Satellite National D'Observation De La Terre--PROJECT SPOT," Centre National D'Etudes Spatiales, Paris, France, Centre Spatial de Toulouse, Document CST/D863, 31 October 1977, pp. 1-30	
16. Abstract This report contains information about the meeting of the Economic and Social Committee held recently. This meeting examined the programs and means currently being implemented by France in the field of space politics. The study took into consideration new directions in the field of space research and industry which could bring about fast results. This was prompted by man's desire to insure rational resource management of his planet and by man's awareness of the definite contribution that space observation can make to this field of research. Through discussion, the Economic and Social Committee has approved the plan for creating an earth observation satellite. Included in this report is a detailed discussion of the principle characteristics of this earth observation satellite. It is outlined to include the objectives, the orbit, characteristics and operations of the platform, maintenance, attitude measurement, the power available and many other characteristics of this project satellite.					
17. Key Words (Selected by Author(s))			18. Distribution Statement Unclassified-Unlimited		
19. Security Classif. (of this report) Unclassified		20. Security Classif. (of this page) Unclassified		21. No. of Pages 33	22.

NATIONAL CENTER FOR SPACE STUDY
TOULOUSE SPACE CENTER

PRINCIPLE CHARACTERISTICS
OF THE NATIONAL EARTH OBSERVATION SATELLITE

PROJECT S P O T

Document approved by:

Chief, Division of Earth Observation	M. Cazenave
Leader of the Project SPOT Systems	
Group	M. Courtois
Platform Project Head	C. Guionnet
Payload Project Head	A. Mizzi
Chief, Department of Earth Exploration,	
Program Office	G. Weill
Director, Toulouse Space Center	J. C. Husson

Document CST/D/863, October 31, 1977

PRINCIPLE CHARACTERISTICS
OF THE NATIONAL EARTH OBSERVATION SATELLITE

PROJECT S P O T

1 - Introduction

/2.

An Economic and Social Committee which met September 19 and which was presided over by the Prime Minister examined the programs and means currently being implemented by France in the field of space politics.

The study took into consideration new directions in the field of space research and industry which could bring about fast results. One of these directions is prompted by man's desire to insure rational resource management of his planet and by man's awareness of the definite contribution that space observation can make to this field of research. This concerns a readily evident anxiety on the part of the developed countries desiring within their own boundaries to make rational use of ocean potential relying on a detailed knowledge of the available resources and on an overall and systematic use of the ocean potential. However, this also concerns those countries that have recently entered the industrial age and desire to discover rapidly and reliably the possibilities of their soil and their sub-soil which as yet have been poorly studied.

This is why the Economic and Social Committee has /3. approved the plan for creating an earth observation satellite pointing out that the characteristics and details for carrying out the program will have to be delayed for two months.

The goal of this report is to set forth the principle characteristics of this earth-observation satellite which was essentially the ^{sub}subject of a detailed discussion in the report published by the National Center for Space Study in March 1977 under the title: Report on the Phase A Study - Test System for the Earth Observation Satellite.

This report with 1800 pages of studies consists of the following volumes:

- volume 1 - System Analysis and Development Plan
- volume 2 - Multimission Platforms, Platform Conception
- volume 3 - Multimission Platform, Sub-Systems
- volume 4 - First Mission Payload
- volume 4a - First Mission Payload (continued)
- volume 5 - Means of Dependence and Obtaining an image

This report is available at the Toulouse Space Center. One can consult it at the main office of the National Center for Space Study.

Following cooperation with the European Space Agency, some minor modifications have been made on the platform since that date to improve some of the operations. The fourth solar panel which one will find in the plans, is not pictured in those of March 1977.

2 - General Idea of the SPOT System

/4.

2.1 - General Idea of the SPOT System

The general objectives of the earth observation satellite are varied: exploration of the planet's resources, detection and prediction of natural phenomena in the fields of climatology and oceanography, surveillance of natural phenomena, etc.

Space remote sensing has a particularly fruitful use in carrying out these missions which form a part of research, study and diverse experimental programs. This variety of purposes which are proposed for the instrument should be adaptable and encompass a variety of missions.

The idea of SPOT was conceived in this context, one of the essential elements of which, the satellite, includes a polyvalent platform which is capable of carrying payloads for different types of missions. The European launcher Ariadne is completely compatible with the multi-purpose platform of this type.

The main theme for the first mission is territorial utilization (evaluation of resources, identification and prediction of harvests, updating inventories, etc.).

The corresponding payload consists of two high-resolution instruments which permit taking multispectral pictures in the visible spectrum. It also includes the means for on board image data recording as well as the appropriate remote measuring system.

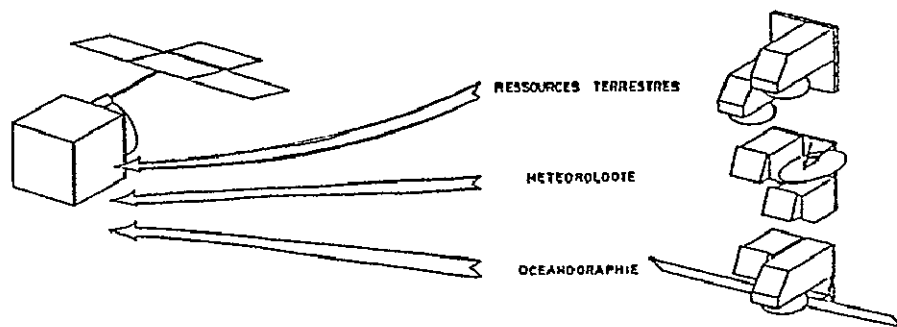

Figure 1. Concept of the Foundation
 Standard platform
 Specific payload of the mission
 - terrestrial resources
 - meteorology
 - oceanography

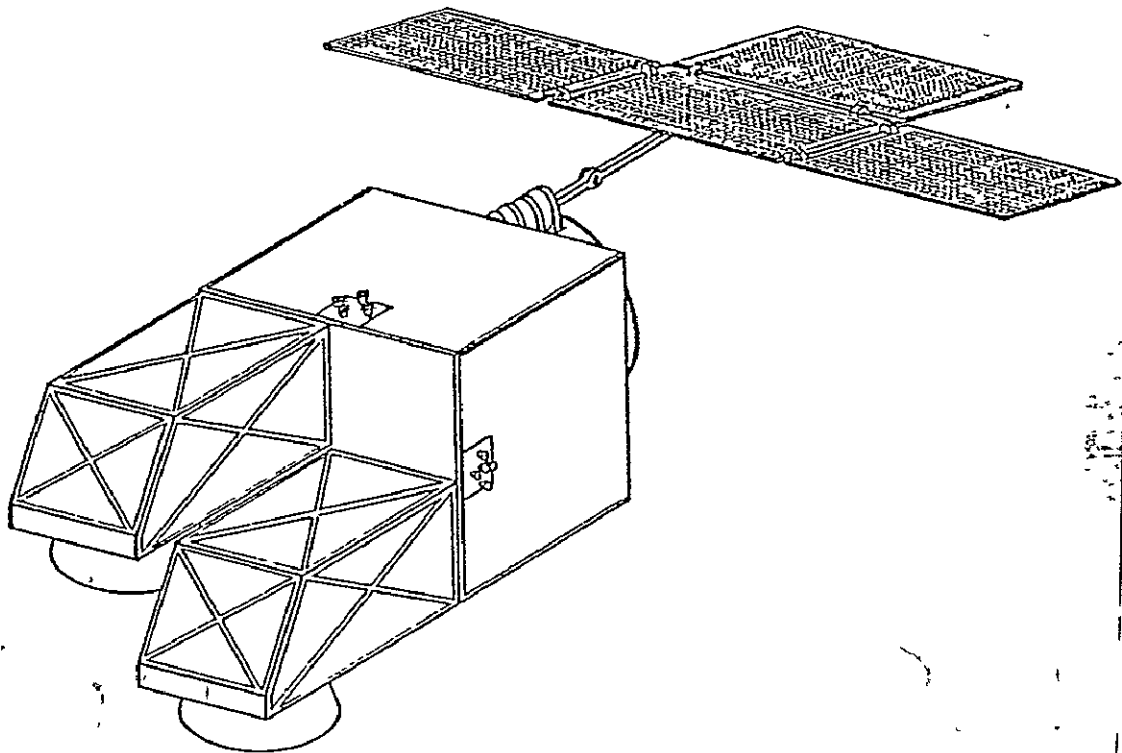

Figure 2. Platform with two high visible resolution instruments

By taking into account the technical requirements involved in the missions anticipated, it was possible to study the SPOT system, to determine its design and to demonstrate its feasibility.

/6.

The repeatability of the observations, the width of the trajectories to the earth, the recovery, the resolution to the earth, the duration of visibility of the stations are the characteristic parameters which are the object of elaborate research.

The multipurpose platform is operable at altitudes of 600-1200 kilometers and at a local time between 8 and 16 hours at an ascending or descending node; the orbit phase is controlled. The platform is also useful for other types of payloads (observation in the spectrum, in infrared, or in the domain of microwaves); the interfacing of the platform, the payload as well as the attitude control have been particularly studied to allow this polyvalence. The architecture of the platform improves the modular design which permits the reuse of the object at the least cost with the least amount of delay of most of the materials developed for the first application.

The multipurpose platform includes auxiliary systems which insure the essential functions of controlling the circular, heliosynchronous orbit, of controlling the attitude (with the necessary precision to produce a quality picture per specifications), of managing a program of activity on board,

of remote measuring, heat control, power and correct n direction of the solar generator. A sub-system to collect data from beacons located around the world or in the air is installed on board. This permits a complete observation by simultaneously processing the "true earth" data.

2.2. Technical characteristics of the standard platform:

The following table presents the performance data of /7. the platform and the areas of its applicability.

Designation	Area of Applicability	Remarks
<u>Orbit</u>		
. type	circular helio-synchronous	Phases for anticipated orbits. The satellite passes strictly above the same point at the end of Q days
. altitude	600-1200 kilometers	
. local time ascending or descending node	8-16 hours, local	
. slopes	the conditions	98.6°
. period	of the circularity, the helio-synchronization, phase, determine	Example 101 mn.
. number of orbits per day		for 14.3
. average duration of visibility by one ground station	all of the parameters of the orbit as soon as the altitude is given	H=809 km. 500 s.
. number of passes per day in visibility by one station		5 to 6 13 days

(table continued)

. Q repetition rate	phase orbit	
. <u>Life duration</u>	two years	
. total <u>mass</u> of of the platform	290 kg. without propellants	100 kg. allowance for possible additional apparatus
. permissible pay- load mass	650 kg.	instruments + recorders + remote measuring payload

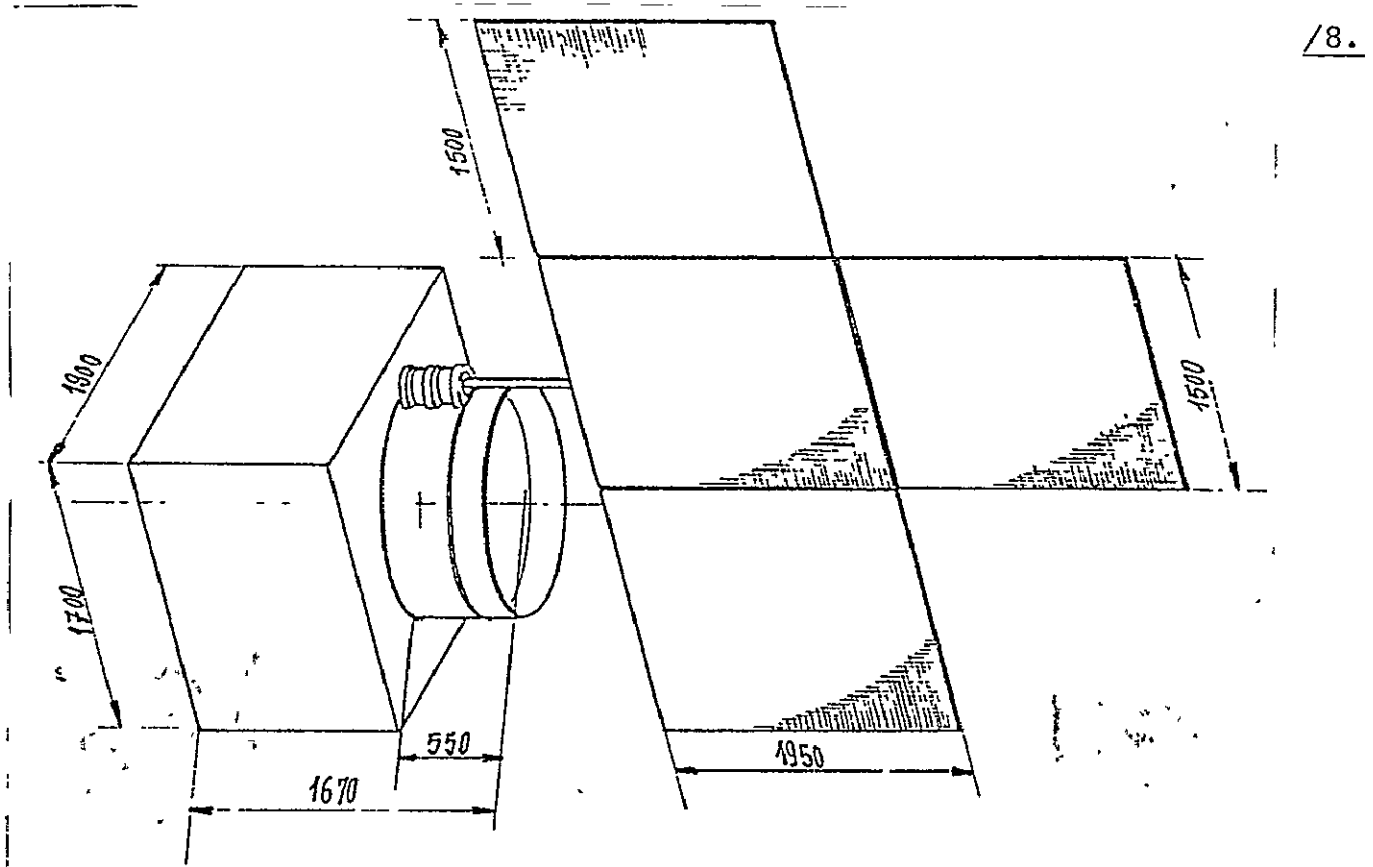

Figure 3. Dimensions of the platform (in millimeters)

Designation	Area of Application	Remarks
<u>Electric power</u> supplied by a solar generator	up to 1200 W at the beginning of its life	Depending on the mission. For an altitude of 800 km. 1030 W. at the end of its life
<u>Remote control - Remote Measuring</u> frequency TC TM transmission power output TM	2025/2120 MHz 2200/2300 MHz ≤ 5W ≈ some kilobits/s	
<u>Attitude control precision</u>	0.15 rolling pitch angle	
angular speed	roll $3 \cdot 10^{-4} \frac{\circ}{s}$ lacing $5 \cdot 10^{-4} \frac{\circ}{s}$ pitch $1.5 \cdot 10^{-3} \frac{\circ}{s}$	outside perturbations internal high frequency
<u>Attitude restoration</u>	the angles are measured on board with a precision of 0.11° to 3σ	

Designation	Area of Application	Remarks

<u>Localisation of the platform</u>		
<ul style="list-style-type: none"> type of measure 	Distance measure Band S (2 Ghz)	attention, the localisation of the points on the ground depends on those of the platform but also on the attitude restoration
<ul style="list-style-type: none"> accuracy of the prediction for 24 hours 	2500 meters along the orbit 500 meters in the two other directions	
<ul style="list-style-type: none"> accuracy in the resulting restoration for all 24 hours 	200 meters	following the three directions and without a control point on the ground

<u>Data Collection</u>		
<ul style="list-style-type: none"> reception frequency 	400 MHz	
<ul style="list-style-type: none"> retransmission to the ground 	by slave remote measuring and/or image remote measuring	application to be determined as a function of the mission

<u>Possibilities of dual launches by the Ariadne rocket</u>		
	Spot + "the little satellite"	
	2 Spot if payload height is limited to one meter	2 x 3.2 m ³ available above the instrument case levels

2.3 - Detailed discussion of the operations of the platform /10.

The platform was designed for various earth observation missions and is equipped with a set of parameters which characterize its operations as well as its usual type of application.

These areas, achieved by a set of examined compromises at the systems level, are not limited by inflexible barriers: if a particular mission overlaps the operations connected with other missions, the results would have to be examined in detail, and the performances would have to be modified to apply to another field.

2.3.1 - The orbit:

The platform is destined to be placed in heliosynchronous circular orbits at an altitude between 600 and 1200 kilometers.

- heliosynchronous because the photographs of the same scene taken at different periodic times correspond to some identical illuminations of the territory flown over.
- in a 600-1200 kilometer range which offers the best possibilities for global covering and for high resolution required by the earth observation missions.
- moreover, the phased orbits allow the platform to fly over the same point at the end of a certain period of several days.

Note: Lower orbits can be planned. Increased atmospheric friction can result in difficulties at the system level of pointing and can cause excessive propellant consumption: at 600 kilometers the period between two rectifications is one week, at 500 kilometers it would be two days (maximum solar activity). Some possibilities of assuring orbits lower than 600 kilometers exist with definite lessening of the performance level.

2.3.2. - Adjustment, maintenance of orbit and attitude. /11.

The sub-system for attitude and orbit control is indispensable in achieving and maintaining a heliosynchronous orbit, generally phased.

The precision of the injection of the Ariadne rocket on the maintained orbits is 0.2° inclination and 8 kilometers over the half major axis. The sub-system attitude and orbital control is adjustable and can maintain an orbit with an accuracy of 0.01° angle of inclination and 50 meters over the half major axis.

- this sub-system insures two functions: /12.

- . reaching and maintaining the orbit,
- . reaching and maintaining the attitude.

- 60 kilograms of propellant are on board, 15

kilograms are consumed when the nominal orbit is attained.

2.3.3. - The pointing

The desire to take pictures of the earth requires a particular orientation of the platform. The requirements of the "geometric quality" of the pictures are expressed, for those that concern the pointing or attitude control, by

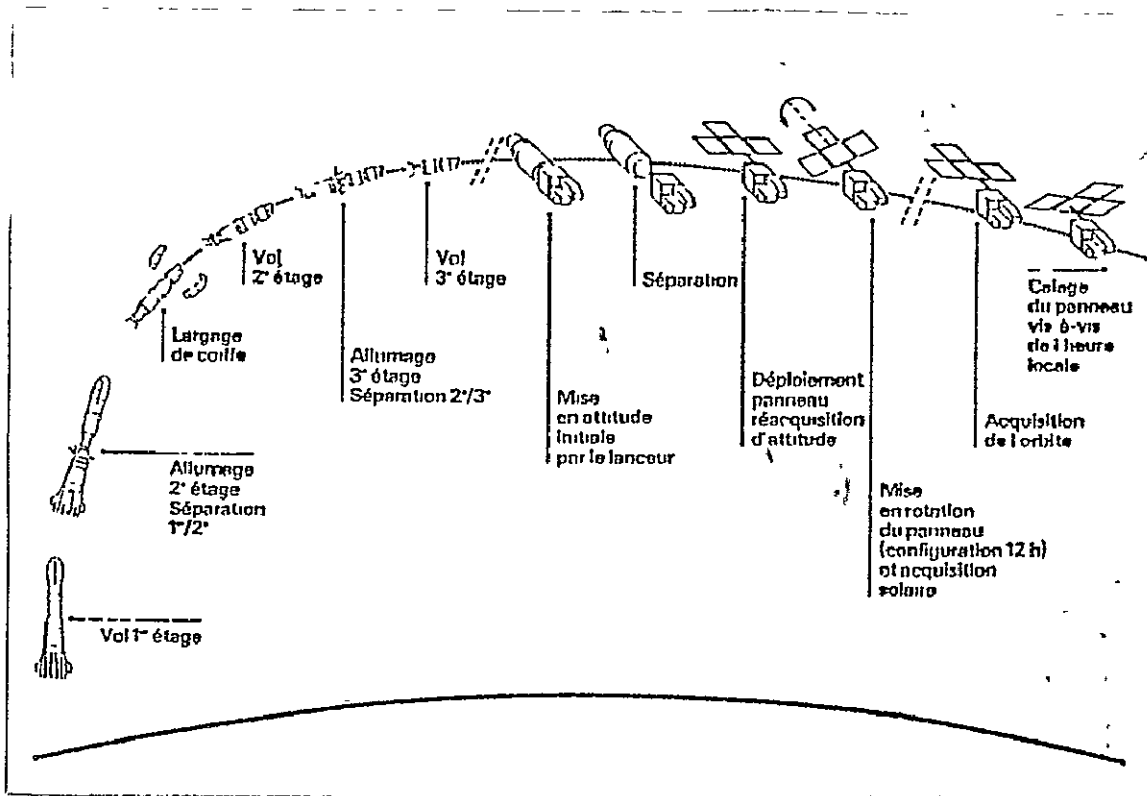

Figure 4. Püt into orbit by the Ariadne rocket since Kourou (Guyana Space Center)

Being put into orbit and sequence for attaining the attitude

1st flight stage; firing, 2nd stage, separation; dropping the nose cone; 2nd flight stage; firing, 3rd stage separation; 3rd flight stage; put into initial orbit by the rocket; separation; deployment of the attitude correction panel; put into rotation of the panel (12 o'clock position) and solar acquisition; reaching orbit; panel adjustment for local time.

by the relations between the angles and the rolling speed, the lacing and pitching. The principle function of the attitude control is to maintain, during the picture-taking phase, the angles and their variation speed within the narrow limits resulting from these relations.

The operations indicated in the preceding table (paragraph 2.2.) are obtained from existing technologies or in the course of qualification and correspond to the requirements of a set of observation missions.

2.3.4! - Attitude measurement

It is insured to within a tenth of a degree (1,400 meters to the ground for an altitude of 800 kilometers) to 3σ .

For some instruments, and in particular for the hyperfrequency payloads requiring a very exact attitude correction on the ground, the measurements of the angles on board can be improved by adding additional devices (a stellar sensor), an integral part of the payload.

2.3.5.--- Available power.

The power is applied to the craft by a solar generator permanently oriented towards the sun.

The available surface for solar cells measures 11.7 m^2 which yields a maximum power of 1200 W at the beginning of its life and 1030 W at the end of its life at an altitude of 800 kilometers.

The power consumption of the standard platform is approximately 300W on the average.

/13.

The modular design of the power system furnishes a maximum power of of 2 kW per payload for approximately 10 min. per orbit each day. Night operation is of course possible on available power depending on the mode of operation (for example 1.5 kW in 10 minutes).

As an example, 2 kW permits the simultaneous operation of two different optical instruments and of a lateral radar as well as those of the recording devices or of the transmission of a payload of this type.

2.3.6. - Remote measuring - remote control - on-board management

. Slave remote measuring transmits data relative to the platform. Contrary to the payload remote measure, the demand for this data is small, on the order of several kilobits per second.

It transmits on the S band (2200 - 2300 MHz) through a helicoidal antenna, with a transmission power of several watts.

The remote control is realized on Band S (2025 - 2120 MHz) and acts on the function of the platform.

It is the access channel from the ground to the satellite, mainly in order to program the computer so that it corresponds to the time-lag on the satellite. The programming can be done each time the satellite passes within sight of the mission control.

- . The remote control can be direct, at real time, for particular operations, mainly at the beginning of the orbital cycle, when the satellite is visible from the earth station.
- . An on-board computer controls the operations of all satellite functions:
 - it adapts the controls of the sub-systems of the platform to different configurations, /14.
 - it generates the remote control formats adapted to the necessary controls during the different operation stages,
 - it programs the activity of the payload and manages the platform/payload interface.

2.3.7. Placing of the platform.

The placing of the platform is maintained by a distance measuring system operating on the S band.

The performances permit for a twenty-four hour period a precision of 2500 meters along the orbit and 500 meters in the two other directions.

A posteriori, the handling of the information collected permits obtaining a restitution precision of the orbital characteristics of 200 meters for the entire twenty-four hour period.

2.3.8. Information collection

The system for collecting information from the ground beacon functions according to the Argos system principle developed at the National Center for Space Study, which will be used on the American satellites Tiros-N beginning in

1978.

Data on board is collected at a frequency of 400 MHz. The data are retransmitted to the earth on the slave-remote measurement system and/or on the payload remote measuring system.

2.3.9. Satellite mass

The platform mass is 490 kilograms without propellants, 550 kilograms with propellants.

It is designed to accommodate, if necessary, the slave elements (batteries, supplementary equipment...) with a limit of 100 kilograms, which yields a maximum mass of 590 kilograms without propellants.

The structure of the platform is designed to accommodate /15. a payload with a total mass less than or equal to 650 kilograms. The total mass of the satellite can then be 1300 kilograms.

Note: These masses permit us to plan double-launchings, keeping in mind the performances of the Ariadne rocket:

- either launching Spot mounted on a "small" satellite different from the Spot satellite,,

- or in a case when one would like to launch simultaneously to Spot models, limiting the height of the payload above the framework of the placing (payload/platform interface) to 1 meter for each satellite. This is equivalent to 3.2 m³ available for each payload and one ton for the both payloads for one orbit less than 800 kilometers,

Of course, one must develop a structure which includes the first /16. satellite and carries the second with an adapted separation system.

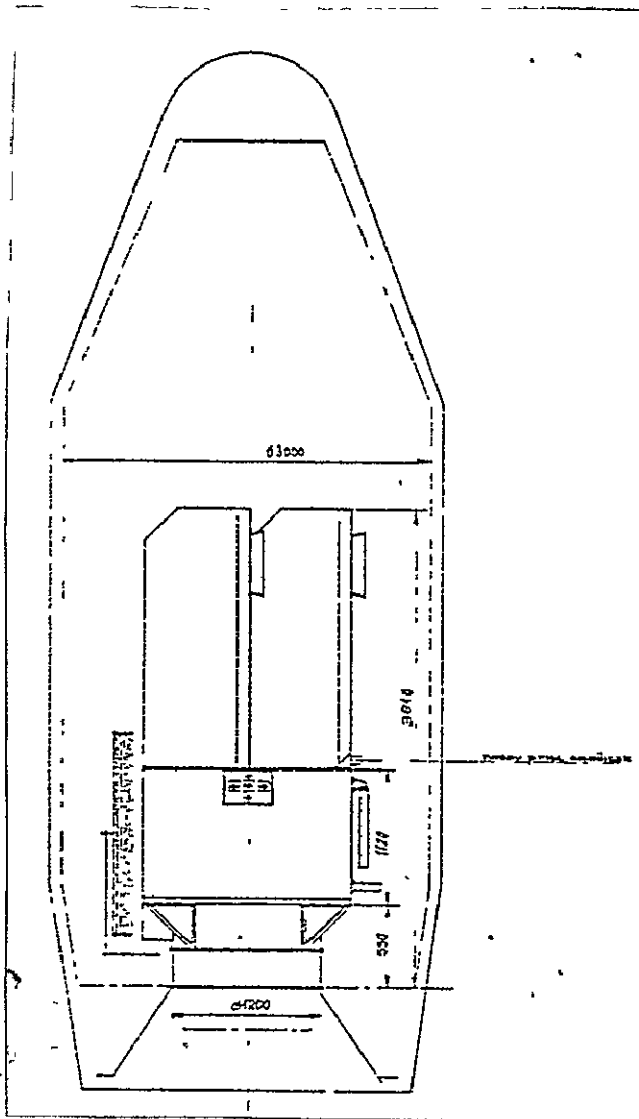

Figure 5. Spot satellite 15.
with two high resolution
instruments on the nose
cone of the Ariadne rocket.

2.4. Platform capabilities

/16.

The entire mission as provided for in the objectives for observing the earth at an average altitude can be completed by the standard Spot platform. Of course, this mission is subject to certain conditions.

If a particular mission fails to satisfy one or another condition, it is necessary to conduct a separate study. The National Center for Space Study can conduct this study quickly in response to the request of the user.

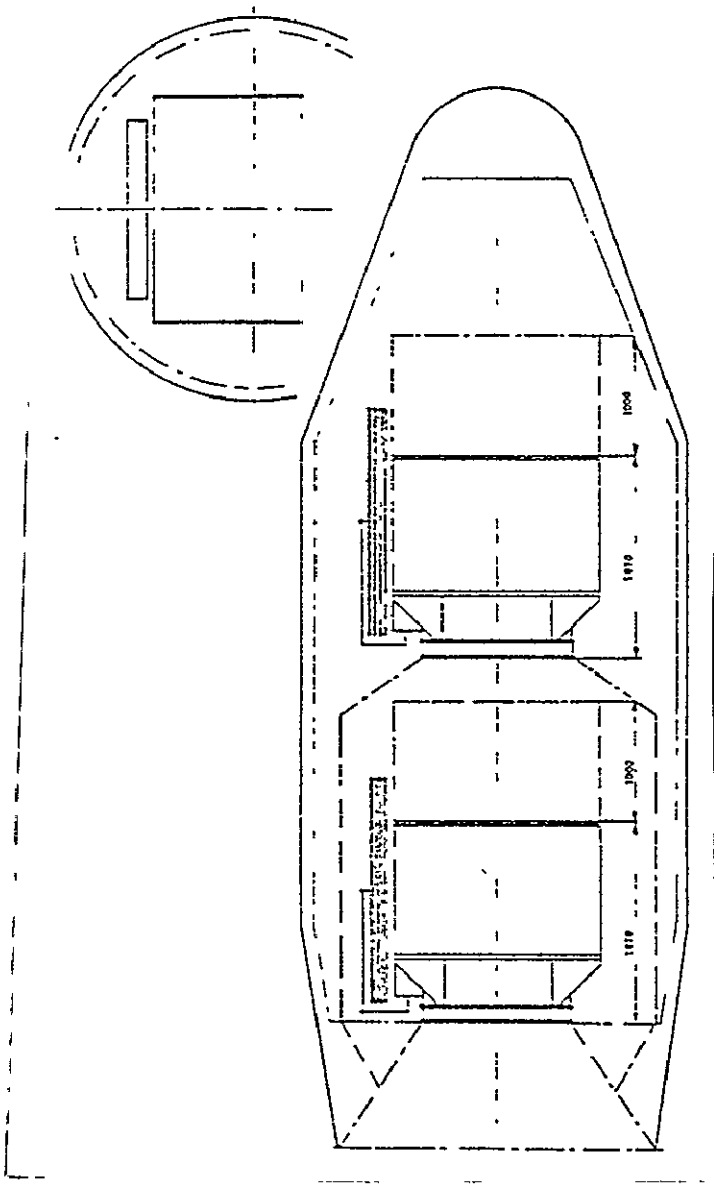

Figure 6. Two Spots in the configuration for a double launching.

3. Payload of the first mission

/17.

The first payload of the national earth observation satellite consists of:

- two identical high visible resolution instruments,
- a recording device on board which permits taking pictures from any point, outside of the visibility of the picture receiving station,
- a transmitting unit for remote measuring imagery.

3.1. High visible resolution instrument

This very ambitious instrument, for the needs of space

resolution, requires a new type of fitting to break through the limits of the mechanical scanning system of utilized to this day. This technique is called push-broom scanning.

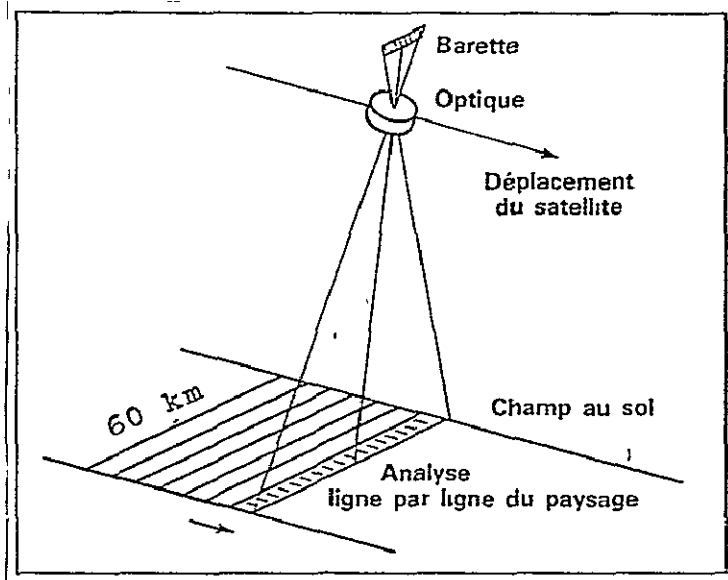

Figure 7. Illustration of the push-broom scanning technique.

The essential characteristic of this device is to effect picture taking without any mobile piece (a scanning mirror, shutter or modulator disc).

This is achieved by using an unusual type of scanning by /18. today's standards:

- the formation of an image line results from the presence of a line of detectors in the focal plane of the instrument,
- the succession of the lines of the image result from the movement of the satellite on its orbit. An additional advantage of this type of scanning technique is that the efficiency of the picture taking* is close to 100% in

construction".

*The efficiency of the picture taking is measured by the relation between the time devoted to the effective acquisition of useful data and the total time of the scanning cycle.

This technique based on the utilization of power-transfer detector rods consisting of 1728 sensitive elements* of 13 microns combines two considerable interests:

- a time for maximum placing on each point of passage,
- great mechanical simplicity which also has the advantage of furnishing an excellent geometric quality of images, by construction (see photography)

*Note: on the high visible resolution, 4 rods of 1728 points will be implanted by the spectral band. Some regroupings are equivalent to 3000 points (26 μ) or 6000 points (13 μ).

The high visible resolution instrument has two principle modes of operation, which, for an orbital altitude of approximately 800 kilometers, consists of the following characteristics:

Space resolution (aimed at the nadir)	Multispectral mode	Panchromatic mode
	20 meters	10 meters
Width of the image or field of view	60 km.	60 km.
Number of spectral bands	3 or 4	1
Width of the spectral bands	\geq 50nm	\geq 400 nm
Amount of information to be transmitted (code 7 bits)	21 or 28 Mb/s	28 Mb/s

In their construction, the rods corresponding to the multispectral mode of operation are implanted with precision such that on the ground one is able to make the /19. measurements taken correspond to the different lengths of the wave to 0.2 close elements (4 meters).

This very exacting operation for the construction of the instrument is necessary to permit the interpretations utilizing the multispectral character of the data.

3.2. General characteristics of the image

The quality of the images obtained can be defined in the following terms:

- geometric quality,
- radiometric quality.

The criteria for geometric quality includes the defects in the elements of the system, that is:

- the rotation of the earth during the picture taking,
- error in pinpointing the position of the satellite at the moment of the picture taking,
- error in the aiming due to the tolerance on the stabilization of the vehicle,
- the geometric defects of the picture-taking instrument, properly so called.

However, in the evaluation of the geometric quality one takes into consideration the corrections which can be made on the ground by a standard preprocessing limited to corrections at the level of one "line" of the image.

The geometric quality is expressed by the precision of the absolute positioning and by the local distortion of the image.

For the first Spot mission the characteristics consist of the following:

- precision of the absolute positioning: 800 meters (1σ)
- global distortion of the image: <1%

Obviously, if one uses a more elaborate process, particularly utilizing the coordinates of a certain number of points of the ground control, the geometric quality of the image can be improved to an important extent.

The geometric quality can be simply defined as the /20. smallest variation in the detectable reflectance from one zone to another of the image.

For the first Spot mission it is better than 0.5% for three of the four spectral bands envisaged in the multispectral mode.

3.3. Different operational modes for the first payload /22.

3.3.1. - Resolution and spectral bands

Each of the two high visible resolution instruments, independent of and at the discretion of the user, can be used following one of the two following operational modes:

- either with a resolution of 20 meters in the multispectral mode,
- or with a resolution of 10 meters in the panchromatic mode.

3.3.2. - Field and angle of sight

REPRODUCIBILITY OF THE
ORIGINAL PAGE IS POOR.



For a satellite altitude of approximately 800 kilometers, the repeatability of the systematic global covering would be 13 days or more for latitudes greater than 56°.

The repeatability of global covering increases at lower latitudes and reaches 27 days at the equator.

At latitudes below 56°, one can obtain the same repeatability of 13 days but only for regions 1115 kilometers wide located at any point of the globe.

b) experimental mode

The aim of this operational mode is to observe the same zone at different angles in order to obtain a stereoscopic view or a stereoradiometric view of the landscape.

On Spot I this mode will only be experimental in the sense that it will be tried, the performances of the nominal solution will not be guaranteed, particularly the quality of the image.

There are three solutions to be studied. The choice will be final in 1977, by comparing their performances and their respective technical difficulties.

b.1: Stereoscopy from orbit to orbit

/24.

This solution consists of observing a zone from two different angles during the course of two different orbits.

One cannot hope to make observations from one orbit to the next because this would result in prohibitive angles of incidence for the access mirrors of the instruments: on the order of 55°. To the contrary, acceptable, reasonable angles of incidence (approximately 23°) associated with a wise orbital choice will permit a reduction of approximately

4 days in the worse case (equatorial zone), the space of time between two orbits on which the stereoscopic observation of a particular zone will be carried out.

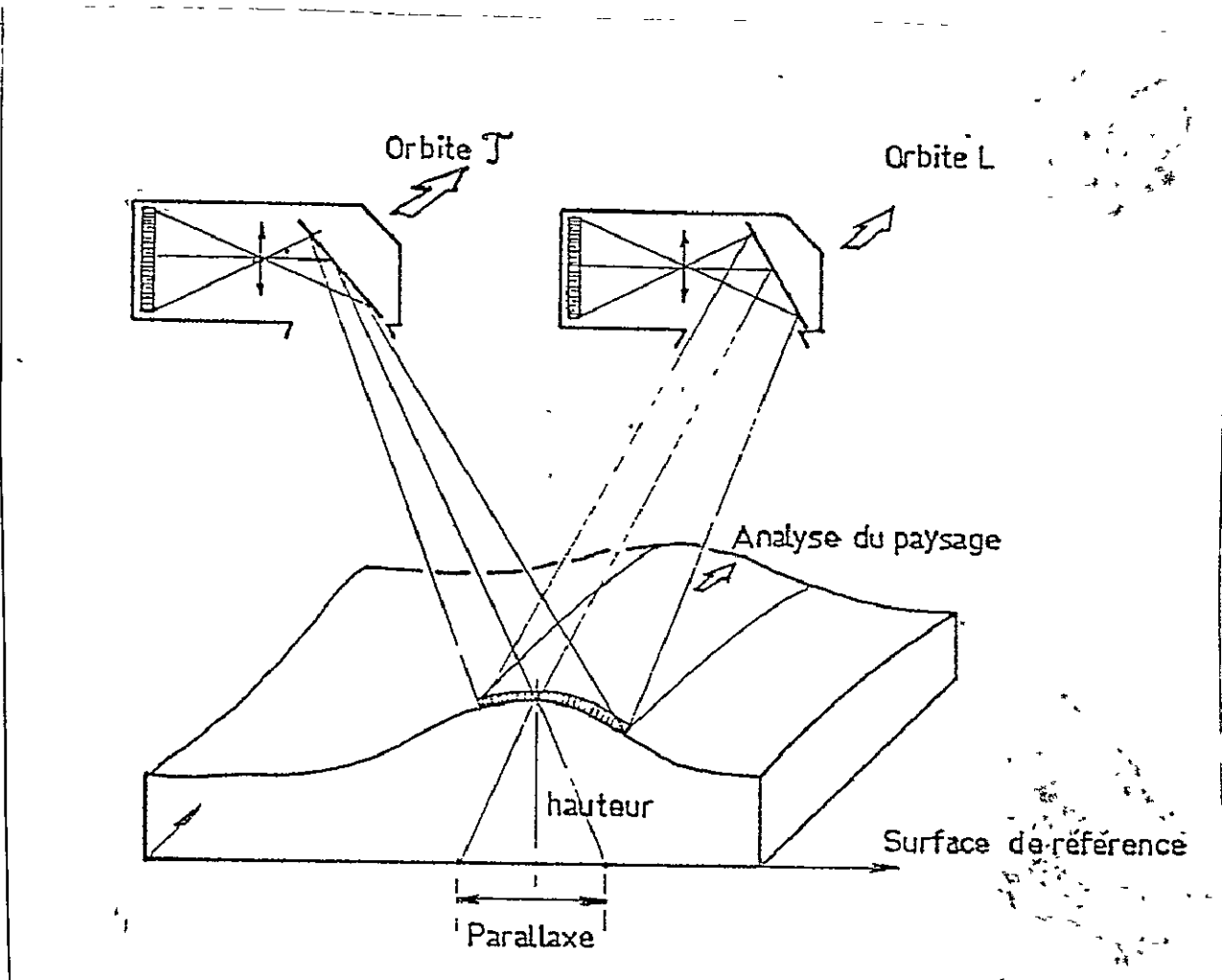

Figure 8. Principle of stereoscopy from two different orbits.
Orbit T, orbit L; analysis of the landscape; height, parallax, reference surface.

b.2. stereoscopy during the course of the same orbit /25.

The solution consists of observing the same zone with the same instrument, first from the front, then from the rear, during the course of the same orbit. The access mirror of this instrument would have one degree leeway in the direction of the path. The mirror of the second instrument

retains the same characteristics of the nominal solution, i.e. it would have one degree leeway in the transverse direction.

This solution presents some problems:

- the field of one of the two instruments losing its degree of leeway in the transverse direction, the possibilities of global exploration become less effective,
- the two instruments are no longer identical,
- the redundancy of using these two instruments is reduced.

b.3. a variation of the preceding solution

It consists of permitting the total rocking motion of each of the two instruments which would observe the same zone at different times, the first toward the front, the second toward the rear. The technical difficulty is caused by the necessary weights to make the instruments rock: approximately 100 kilograms for each instrument.

3.3.3 Conclusion on the choice of parameters for the orbit agreed upon for the first mission

Definite parameters as well as the maximum angle for lateral pointing error, for the duration of the systematic covering cycle, always maintaining an altitude of approximately 800 kilometers, is expected by the end of 1977, after the conclusion of related studies for the first mission.

3.4. Possible spectral bands for the first payload 726.

3.4.1. Imperative techniques for choosing the bands

The high visible resolution instruments in the "color" mode of operation can a priori be designed for 3

or 4 separated spectral bands observed simultaneously. The selection of these bands is linked to the following techniques:

- to the interior of the band with a silicon sensitivity from 480 to 1050 nm,
- assuring reflectance discrimination from 0.5% under particularly clear conditions,
- leaving between two contiguous bands a gap of ≈ 20 nm imposed by the principle of dichroic separation,
- compatibility with the remote measurement capacity of transmitting seven bits for each instrument on 4 coded channels
- having taken into consideration, to the limits of the spectral sensitivities, the irregularities of the spectral response (blue side) and of the degradation of the space resolution by diffusion in the detector (infrared side).

The selection is, of course, linked to these thematic imperatives:

- discrimination of different types of terrains,
- detection of waters on the surface and of their characteristics of their cloudiness,
- differentiation between types of vegetation.

It is important to maintain a certain level of compatibility with the spectral bands of the multispectral scanner (Landsat 1, 2, C and D of the Thematic Mapper Landsat D) in order to immediately benefit from the accumulated experience to interpret the information from the sensors.

3.4.2. Proposed bands for the first mission of the national earth observation satellite /27.

Close infrared band

This band is the one that "crosses" the atmosphere the best (atmospheric transmission ≈ 0.95 for a model of the clear atmosphere) and even of light fog. All of the vegetation is clearly depicted, the water surfaces are dark. (reflectance $\approx 1\%$, abatement factor 10 to 50 m^{-1}).

The upper limit of this band can be fixed at 0.92 or $1.05 \mu\text{m}$. It merits particular attention in comparing the advantages of a slightly improved contrast between the water and the terrains, a slight improvement in the radiometric precision and an indication of the total content of the atmosphere in water vapor and the disadvantage of a degradation of space resolution. The lower limit of the wavelengths could be chosen quite freely up to 750 or 800 nm; the contents of the information from the multi-spectral bands 6 and 7 is, in effect, a little different.

Red band

This is band 5 of the multispectral system, as provided for in the Thematic Mapper, it contains the most information, separating the agriculture, open terrain, rocky surfaces. Atmospheric transmission by clear sky ≈ 0.90 , penetration in clear water is ≈ 2 meters (abatement $5 \cdot 10^{-1} \text{ m}^{-1}$), the reflectance of the water being $\approx 4\%$. The band embraces a minimum of vegetal reflectivity due to maximum absorption of chlorophyll. Used with the infrared band it permits an evaluation of the vegetal

biomass. The band must be maintained at all cost. The margin of selection is very narrow.

Green band (or green and blue band)

The spectral domaine that embraces 550 nm corresponds to a maximum reflectance of the vegetation between 2 maxima of absorption of the chlorophyl. This is the vegetal green. The possibilities of distinguishing the species are bound to the differentiation of the leave pigments.

The band almost coincides with a wide minimum of clear /28. water abatement, that which permits penetrating the cloudiness for the first 20 meters (abatement factor $5 \times 10^{-20} \text{m}^{-1}$ for clear water) but the water reflectance remains weak $\approx 10\%$ and without a doubt more to improve the radiometric resolution than to cut the band into two narrow ones.

Since it is concerned with distinguishing the nature of materials suspended in the water, one should observe with bands more narrow and with a shorter wavelength (rf. Coastal Zone Color Scanner Nimbus G).

3.4.3. Conclusion

The definition of the high visible resolution instruments can be fixed on three bands rather than 4 in order to insure on the green band an improved radiometric resolution, i.e. 0.5% as for the other two bands. This reduction from 4 to 3 bands should be partially utilized at the level of remote measuring to code each of the 3 bands on 8 bits (256 grey levels) so that the coding noise will not limit the radiometric resolution which one can rightfully expect from these

instruments.

The spectral bands and the range of optimization proposed for Spot are as follows:

Green band : 490 ± 10 to 590 ± 10 nm

Red band : 610 ± 10 to 710 ± 10 nm

Near infra-red band : 800 ± 60 to 910 ± 140 nm

The following figure shows how the three spectral bands are located for Spot vis-à-vis the existing satellites (Landsat A and B) or programmed for the future. (Thematic Mapper of Landsat D, Coastal Zone Color Scanner of Nimbus G...).

/29.

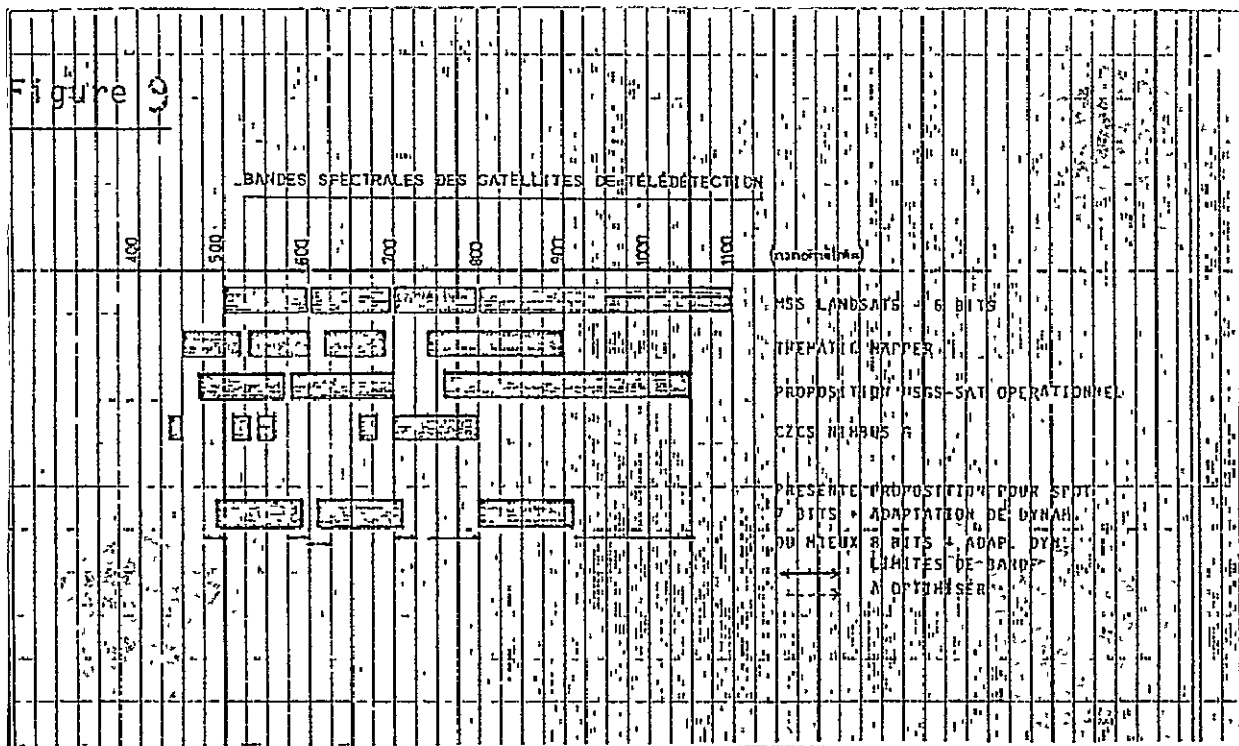

Figure 9. Spectral bands for Remote Sensing Satellites

4. Ground segment

The ground segment comprises:

- a remote measurement station (reception), remote control (transmission) functioning in the S band and permitting the collection of slave data from the satellite, the remote control of the satellite in direct mode or by using the on-board management system,
- a receiving station for the data from the remote measuring image; this will function on the X band (8 GHz) for the first mission. The image will be transmitted by this remote measurement at a speed reaching 56 Mbits per second. This image will have been prestored on board.

This station will be designed keeping in mind its eventual compatibility to receive other satellites with remote sensing (options to be studied).

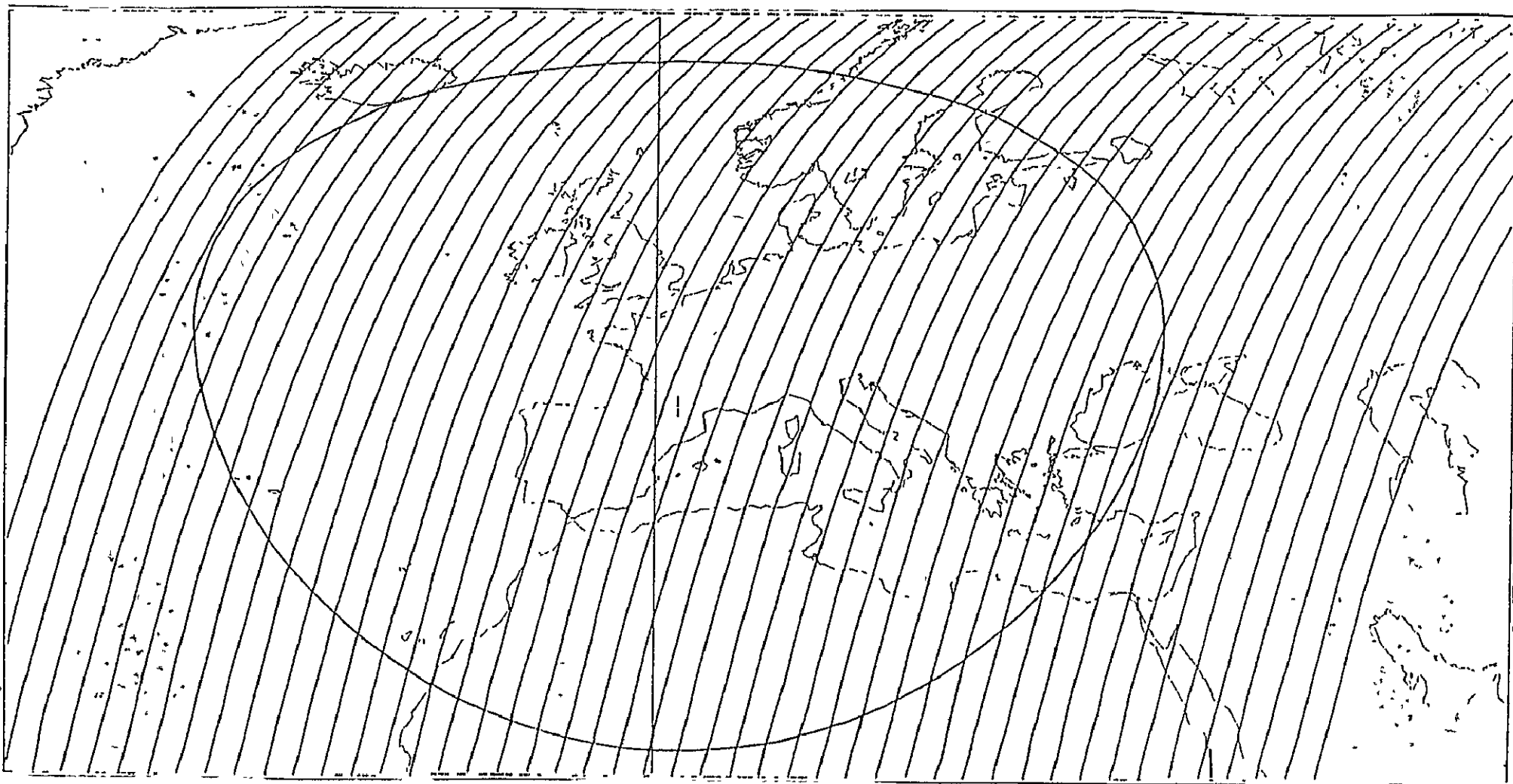

Descending orbits. Visibility from Toulouse (5° of site). Altitude 809 kilometers.