

NASA Technical Paper 1165

CASE FILE
COPY

Design of a Blood-Freezing
System for Leukemia Research

Thomas E. Williams and Thomas A. Cygnarowicz

FEBRUARY 1978

NASA

NASA Technical Paper 1165

Design of a Blood-Freezing System for Leukemia Research

Thomas E. Williams and Thomas A. Cygnarowicz
*Goddard Space Flight Center
Greenbelt, Maryland*



National Aeronautics
and Space Administration

**Scientific and Technical
Information Office**

1978

All measurement values are expressed in the International System of Units (SI) in accordance with NASA Policy Directive 2220.4, paragraph 4.

CONTENTS

	<i>Page</i>
INTRODUCTION	1
SYSTEM CONCEPT	4
THERMAL SIMULATION OF FREEZING PROCESS	6
SYSTEM DESIGN	12
TEST RESULTS	17
CONCLUSIONS	17
ACKNOWLEDGMENTS	18
SOURCES	19
APPENDIX A—EVALUATION OF FREEZING SYSTEM CONCEPTS	A-1
APPENDIX B—COMPUTER PROGRAM LISTING	B-1
APPENDIX C—CONTAINER DRAWINGS	C-1

DESIGN OF A BLOOD-FREEZING SYSTEM FOR LEUKEMIA RESEARCH

Thomas E. Williams and Thomas A. Cygnarowicz
*Goddard Space Flight Center
Greenbelt, Maryland*

INTRODUCTION

Leukemia is a disease characterized by a proliferation of the tissue that forms white blood cells. Although the number of white cells in the blood may either increase, decrease, or remain constant during this disease, the bone marrow in which the cells are formed proliferates.

Treatment of leukemia involves the use of drugs or radiation to kill the cancerous white cells in the blood and bone marrow. This process can cause loss of all bone marrow so that normal white-cell production is not possible. When this loss occurs, white cells must be supplied to the patient.

Several factors make white cells much more difficult to use than whole blood. First, because of the nature of the disease and to prevent rejection, the patient-donor white-cell types, of which there are over eighty, must match. Second, because the normal storage life of white cells is limited to several hours, they must be used immediately after they are donated. Finally, because it takes about 4 hours to obtain a unit of white cells from a donor, the time factor is critical.

For some years, the Experimental Hematology Branch at the National Cancer Institute (NCI) has been working on techniques for freezing and storing white blood cells. The goal of NCI is to establish a bank or storage facility for white cells. NCI has found that white cells are considerably more difficult to freeze and store than red blood cells, and believes the most important parameter during the freezing process is the rate of temperature change. Experiments have shown that improved yields of white blood cells result when rudimentary controls are placed on the rate of temperature change. Experimental evidence indicates that, if the cells are cooled too quickly, they are destroyed by rupture of the cell membrane. If they are cooled too slowly, they are destroyed by dehydration.

The biological freezing equipment previously used by NCI (discussed in Appendix A) did not permit direct control over the blood temperature, and, consequently, large deviations from the desired rate of temperature change occurred during the freezing process. In

addition, because of sample-to-sample variations, the freezing rates were not consistent or repeatable. Testing had advanced to the point where they needed a system that could freeze different lots of blood in a repeatable manner, and NCI sought technical assistance in developing such a system. In conjunction with NCI, the Technology Utilization (TU) Office at National Aeronautics and Space Administration (NASA) Headquarters asked the Goddard Space Flight Center (GSFC) to develop the system to meet requirements specified by the researchers.

The basic requirement was to develop a unit that could freeze up to 200 milliliters of white cells from room temperature to 223 K (-50°C) at a constant rate of temperature change. The rate was to be selectable in the range of 1 to 4 K per minute. Special considerations that would directly affect the design were:

- The cooling and freezing characteristics of the white cells and the chemical medium in which they were stored was unknown.
- The concentration of cells and chemical medium could change from sample to sample.
- The white cells and chemicals would have to be maintained in a sterile environment throughout the entire process (before, during, and after freezing).
- Control would have to be maintained while the heat of fusion was being released. The primary problem in maintaining constant rate of temperature change is that the specific heat of the fluid being frozen changes and the heat of fusion must be released at the freezing point. A further complication is the fact that the heat of fusion and specific heat vary from sample to sample.
- The freezing temperature of the blood sample is unknown and cannot be predetermined (i.e., it varies from sample to sample).

During the early phases of the effort, GSFC personnel spent some time with the researchers at NCI in order to fully understand their operation and to determine what they expected from the new system. As a result, it was determined that much of the early experimental and analytical work could not be used in the design of the final system. Because of their technical value and their usefulness in interpreting the experimental test results of the freezing system, the results of this work have been included in Appendix A.

The main portion of this document deals with the freezing system that was designed, assembled, and tested by GSFC and delivered to NCI.

The Problem

The basic requirement for this program was to develop a system capable of controlling the freezing rate of white blood cells in a dimethylsulfoxide (DMSO) solution. The fluid would have to be kept in a sterile bag before, during, and after freezing. Cooling rates of 1 to 4 K per minute were desired for samples ranging up to 200 milliliters.

The problem that NCI experienced in attempting to obtain a constant rate of temperature change while freezing white blood cells is primarily the result of two changes that occur in the fluid during the cooling/freezing processes. First, the specific heat of the blood/chemical mixture changes with temperature. Second, in the temperature range at which the liquid is actually freezing, the heat of fusion must be extracted. If a constant rate of temperature change is to be maintained, the heat extraction rate must be adjusted accordingly. Figure 1 is a typical freezing curve taken from an actual test using a blood/chemical mixture. The dotted line indicates the temperature of the inside of the biological freezer, and the solid line shows the temperature of the blood container.

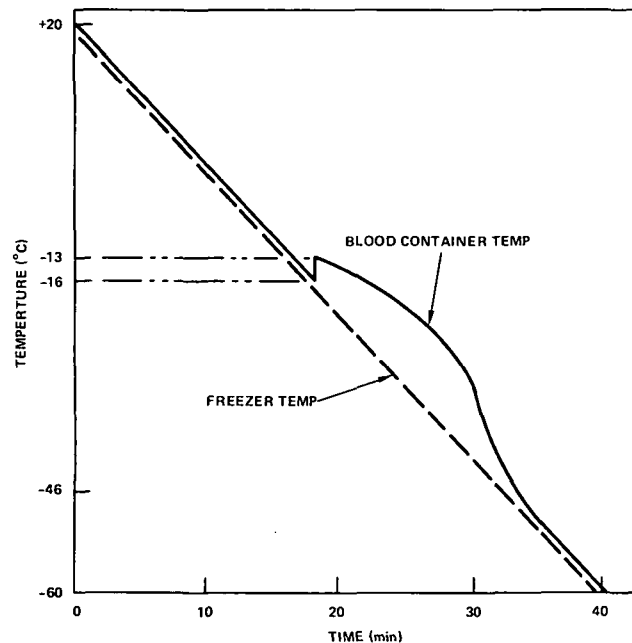

Figure 1. Blood cell/DMSO freezing curve.

For this test, the blood was placed in the freezer at 293 K, and the freezer was cooled at a constant rate of 2 K per minute. Figure 1 shows that the cooling rate of the blood was not constant. The first deviation occurred at 257 K when the blood container temperature quickly rose from the supercooled temperature of 257 K up to the normal freezing point (for this sample) of 260 K where the actual freezing process took place. Because the heat-pumping capacity of the freezer is essentially constant under these conditions, the heat of fusion of the sample cannot be pumped out fast enough, and the blood temperature drops much more slowly than is desired. When the blood container reaches about 238 K and the sample becomes totally frozen, the temperature begins to drop rapidly and eventually returns to the desired -2 K per minute rate of change. The objective is to provide an adjustable heat-extraction capability so that the blood will be cooled at a constant temperature rate.

SYSTEM CONCEPT

Experimental attempts to adjust the heat-pumping capacity by controlling the freezer temperature proved inadequate. Because of its size, the freezer could not react quickly when a change in thermal environment was required. Changes in the blood sample occurred, too quickly for the freezer to follow. Various other commercial freezing systems and proposed concepts (Appendix A) were rejected for either this or other reasons, such as incompatibility with the sterility requirement, NCI handling requirements, or NCI facilities.

A system was developed that could rapidly change its heat extraction capacity, would have minimum impact on NCI facilities and procedures, and would also satisfy all other requirements. This system, shown diagrammatically in figure 2 and photographically in figure 3, consists of three basic subsystems: gaseous nitrogen freezer, blood-container assembly, and electronic control unit.

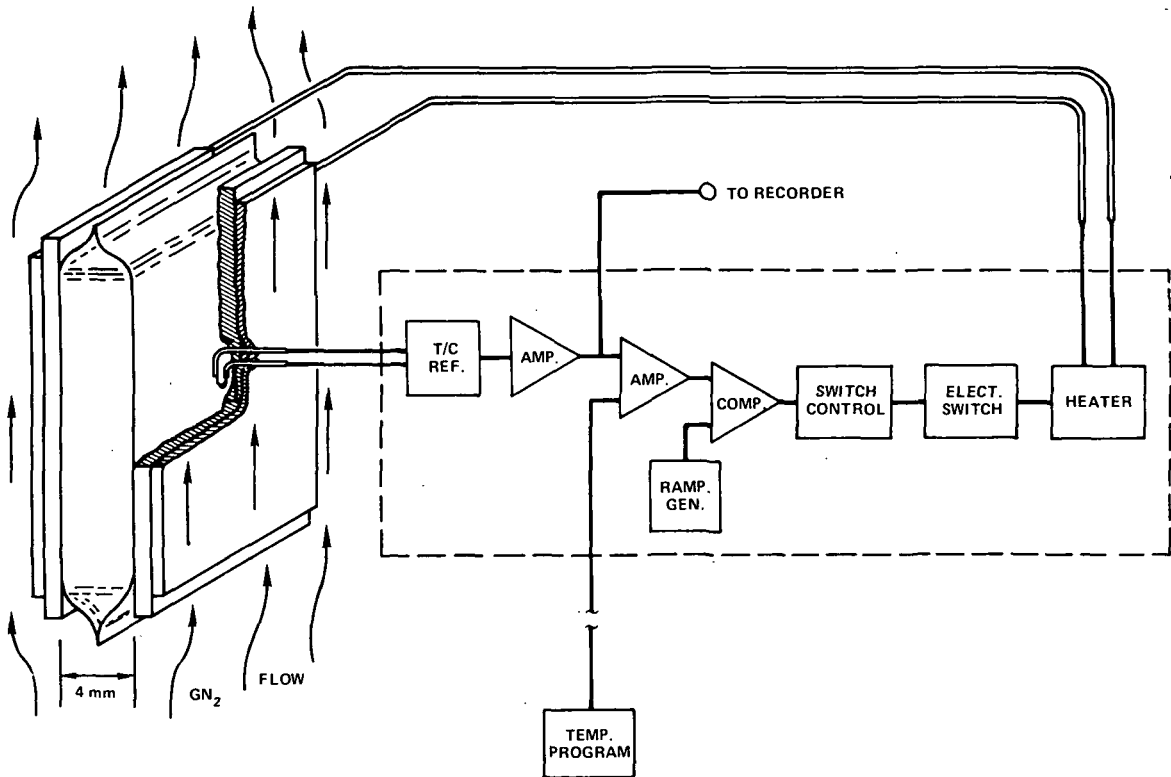

Figure 2. Freezing system block diagram.

The freezer used in this system is a standard biological unit that has a centrifugal blower to circulate cold gaseous nitrogen around the specimens to be frozen. The cold gas comes from an external liquid-nitrogen source and is used to automatically control and adjust the freezer temperature.



Figure 3. Complete freezing system.

The blood-container assembly consists of a polyethylene bag (for containing the white blood cells) that is sandwiched between two hardened aluminum plates. The outer surfaces of both plates are covered with printed-circuit heaters. The freezer temperature is dropped low enough to equal or exceed the maximum cooling rate needed at any time during the freezing process. Heater power is applied to the plates to make up the difference between the heat leaving the blood sample and that required to maintain the specified temperature difference between the freezer and the plates. Reducing the heater power increases the heat-pumping rate from the blood to the cold gas, and raising the heater power decreases the heat-pumping rate. A thermocouple mounted on the inner surface of one plate monitors the blood-bag temperature. Mounting a thermocouple directly in the blood is impractical because a uniform position cannot be maintained and it would compromise the sterile requirement.

The electronic control unit compares the thermocouple (blood temperature) signal with a programmer that contains the desired temperature/time curve. It then controls the power to the heaters to keep the blood temperature at the programmed setting.

In operation, the sandwich assembly containing the blood sample is placed inside the freezer containing the cold gas. The heaters turn on immediately to prevent removal of heat from the blood. From this point, the heater power is automatically controlled by the electronics so that the temperature at the thermocouple tracks the desired profile that is stored in the temperature programmer. For example, if the temperature of the blood begins to increase because of the supercooling effect, the electronics sense the condition and automatically

reduce the heater power. This increases the heat flow through the plates to the cooling gas and keeps the blood temperature falling at the desired rate. If the blood begins to cool too quickly (e.g., when the 293-K liquid is placed in the cold freezer), the electronics also sense this condition and increase the heater power to maintain the desired rate.

Figure 4 is a graph of the results obtained from freezing a sample of white blood cells. In this case, the blood temperature cooled at the constant rate that was preset on the programmer, independent of the freezer-gas temperature. The freezer-gas temperature can be dropped either at a controlled rate or immediately to a lower limit. The only restriction on the freezer is that it be at least 288 K, but not more than 333 K, colder than the desired blood temperature at any given time. The results in figure 4 differ from those in figure 1, which were obtained when freezing the same sample without the electronic controls.

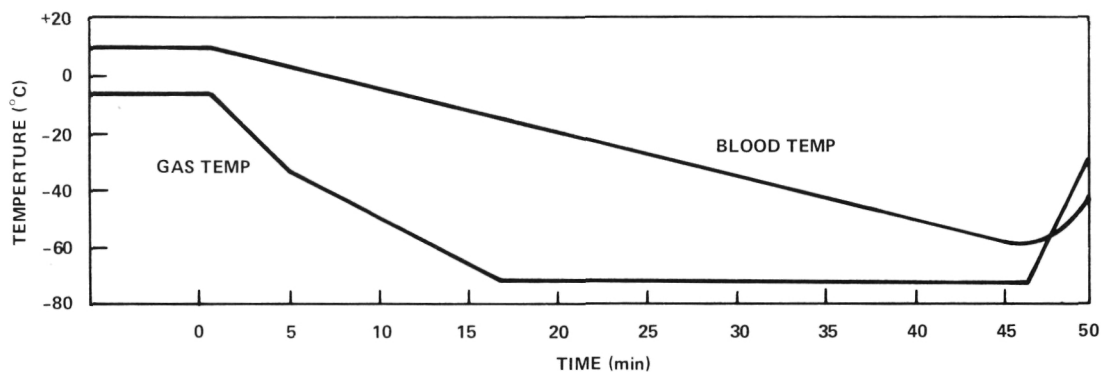

Figure 4. Freezing results of new system.

THERMAL SIMULATION OF FREEZING PROCESS

Early in the program, a thermal analysis was undertaken to:

- Evaluate performance of different cooling systems to determine optimum type of system
- Make hardware design tradeoffs for each system
- Investigate system operational procedure tradeoffs
- Obtain a complete temperature profile of the system and of the fluid for evaluating test data because existing data indicate that the rate of temperature change during freezing of white cells is important in improving yield

In setting up the analysis, every attempt was made to keep the criteria flexible enough to evaluate different types of systems and to permit hardware changes, heater location changes, etc.

The general one-dimensional energy equation with heat generation results in a partial differential equation. This equation would be difficult, if not impossible, to solve for the composite structure with a liquid changing phase to a solid. Consequently, a finite-element forward-difference numerical solution was pursued. Consider the nodal points shown in figure 5. In general, a heat summation at any nodal point n (figure 6) results in the following (when $T_{n+1} > T_n$):

$$\left(\frac{KA}{\Delta X}\right)_{(n+1)-(n)} \left[T_{(n+1)} - T_{(n)} \right] - \left(\frac{KA}{\Delta X}\right)_{(n)-(n-1)} \left[T_{(n)} - T_{(n-1)} \right] + q'''(V)_{(n)} = \left[\frac{\rho C_p V}{\Delta \tau}\right]_{(n)} \left[T_{(n)\tau+\Delta\tau} - T_{(n)\tau} \right] \quad (1)$$

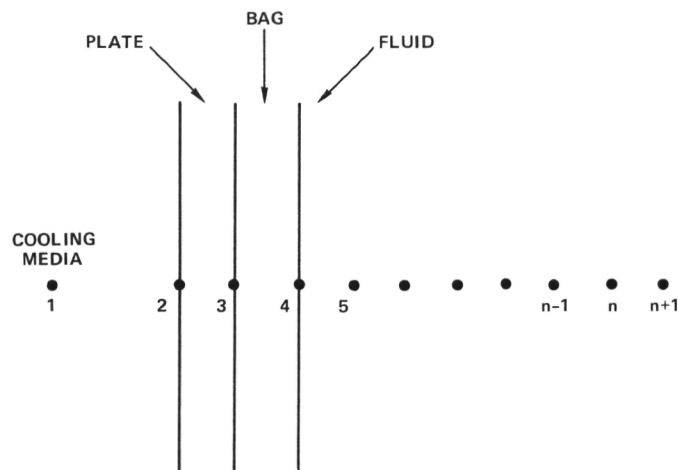

Figure 5. Finite difference heat transfer model.

Each part of the system is broken into one or more nodal volumes, and a finite-difference energy equation similar to equation 1 is written for each node. The q''' term drops out for all nodes except those having a heater.

Heat transfer through the fluid depends on the state of the fluid. The analysis must account for three possible states:

- The fluid is in the liquid state
- The fluid is in the two-phase regime
- The fluid has frozen

When the fluid is in the liquid state, the properties of the liquid are used, and the finite-difference heat-transfer analysis proceeds as for any homogeneous region. The same is true

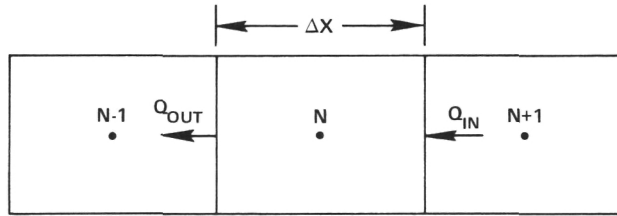

FOR NODE "N":

$$Q_{OUT} - Q_{IN} = \text{HEAT REMOVED} = Q_N$$

$$Q_{OUT} = \frac{KA}{\Delta X} \left[T_N - T_{N-1} \right]$$

$$Q_{IN} = \frac{KA}{\Delta X} \left[T_{N+1} - T_N \right]$$

$$\text{DURING COOLING: } Q_N = (\text{MASS}) C_p \frac{(\Delta T) (\tau + \Delta\tau) - \tau}{\Delta\text{TIME}}$$

$$\text{DURING FREEZING: } Q_N = \text{HEAT REMOVAL RESULTING IN PHASE CHANGE}$$

Figure 6. Nodal heat summation.

when the fluid has solidified, except that the properties of the solid are used. The method of handling the fluid/solid mixture during the freezing process is considerably more difficult.

When a liquid reaches its freezing temperature, no temperature change will occur (excluding subcooling effects) until it has frozen completely. The procedure used divides the liquid into thin layers, with a nodal point in the center of each layer. It is assumed that the liquid in the layer at the n^{th} node will not begin to freeze until the liquid in the layer at the $(n-1)$ node has completely frozen. This assumption is reasonable for a substance that freezes at a constant temperature because a temperature differential is required to transfer heat from the n^{th} to the $n-1$ node, and T_n cannot reach the freezing temperature until T_{n-1} drops below the freezing temperature. It is further assumed that the contents of each layer are homogeneous. (While the heat of fusion is being released, the accuracy of this assumption is dependent on the size of the layers (i.e., the number of divisions in the bag).)

The question arises as to what properties to use when the freezing is initiated in a particular layer. This analysis assumes that the temperature of the layer is constant and uniform until complete freezing has occurred and that the thermodynamic properties are proportional to the amount of heat that has been released after reaching the freezing point. For example, consider a property, n , where n_s is the property of the solid, and n_f is the property of the

liquid. Let H_{sf} be the heat of fusion, and let Q be the amount of heat released during the time period since the freezing point was reached. The property, n , at this time is given by

$$n = \left(1 - \frac{Q}{H_{sf}}\right) n_f + \frac{Q}{H_{sf}} n_s \quad (2)$$

Equation 2 is used only in the two-phase region (i.e., during freezing).

The resulting analysis was programmed for a digital computer. The program listing appears in Appendix B.

One of the inherent problems with a forward-difference solution is that the time and distance steps that are chosen must be small enough to keep the solution stable. In this case, a trial and error solution was used that resulted in the selection of 20 nodes in the fluid with a time step of about 0.01 seconds.

The computer analyses, hand calculations, and laboratory tests were used to evaluate various freezing-system designs. The details of some of these analyses and tests are contained in Appendix A. This discussion is limited to the system selected.

The initial configuration for the system analyzed used the same materials then in use at NCI (i.e., a polyvinylchloride (PVC) bag sandwiched between two brass plates). Early analyses immediately indicated that the freezing control and the response of the fluid to cooling-system changes could be improved by reducing the thermal resistance between the cooling fluid and the fluid being cooled. This was accomplished by switching to thinner materials with higher thermal conductivity and lower thermal mass. The brass plates were replaced with aluminum, and the PVC bags were replaced with thinner polyethylene bags.

Some of the earlier concepts proposed for the freezing system neglected any consideration of the latent heat of fusion, which must be removed to solidify the liquid. The solidifying solution and the components between the solution and the cooling media result in a finite time required for removing the latent heat of fusion. Analyses conducted with water properties resulted in a cooling/freezing temperature profile as shown in figure 7. The subscripts 1, 3, 4, and 6 refer to the cooling gas, the outside of the bag, the first layer of water inside the bag, and the water in the middle of the bag, respectively. It is important to note that even if the bag temperature/time profile is controlled, the temperature/time profile of the fluid inside the bag will be different. In the case analyzed, the actual freezing of the solution was totally dependent on the thermal properties of the white blood cell solution and the system used for the freezing. No electronic circuitry can make the freezing unit perform beyond its thermodynamic limitations.

Figure 8 shows the results of a test that was conducted to duplicate the conditions used in water analyses. Good agreement exists between the analysis and test results shown in figures 7 and 8, respectively.

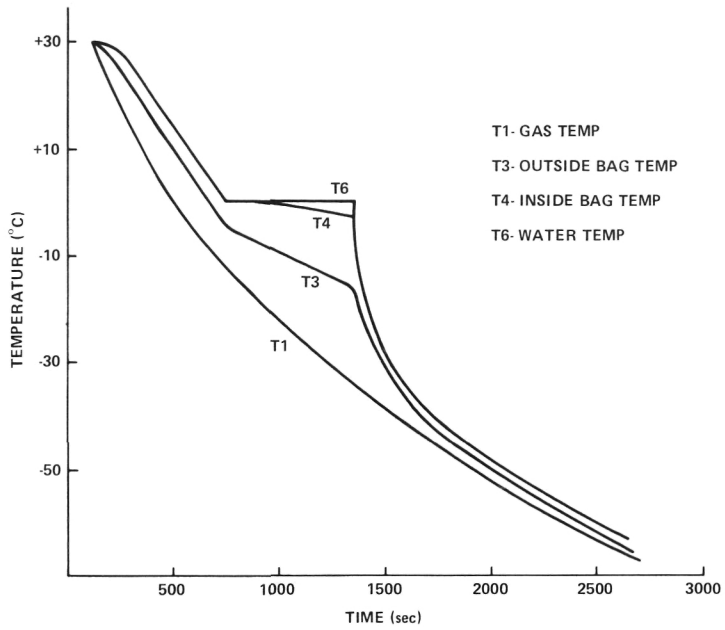

Figure 7. Computer generated freezing curve for water.

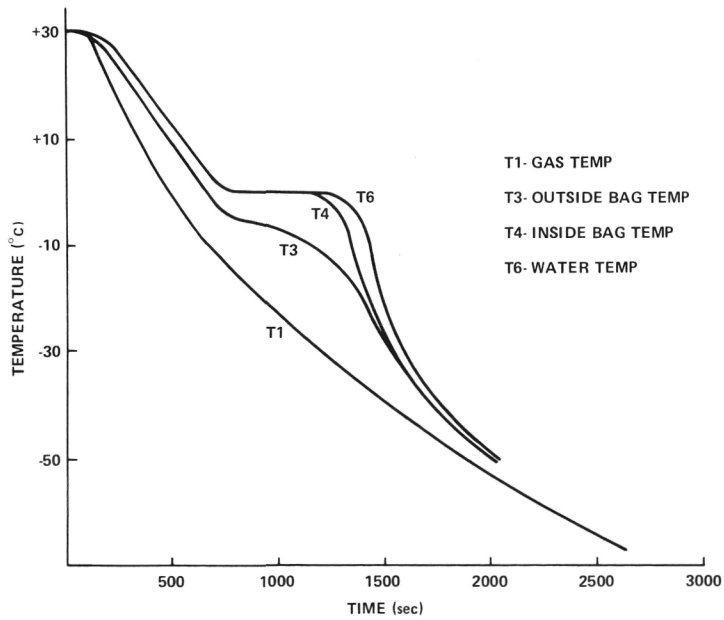

Figure 8. Test generated freezing curve for water.

Although the use of water properties enabled the system tradeoffs to be made with the computer program, more difficult problems were encountered in considering a DMSO solution. Freezing tests conducted with a thermocouple inside a bag of DMSO solution (50-percent DMSO and 50-percent water) showed that the solution experiences a definite subcooling effect of about 3 K. (Some tests with water showed a slight subcooling effect, but it was not repeatable with the accuracy of the test setup.) Figure 9 shows the results of one test. The results show that the solution does not remain at a constant temperature during the freezing process. The specific heat appears to be a function of the amount of fluid that has solidified. Although it was beyond the scope of this program to determine actual thermal properties of the DMSO solution, some effort was made to duplicate the experimental data on the computer program by comparing the experimental data for DMSO to that of water and using a proportionality constant. The properties and resulting temperature profile are shown in figure 9.

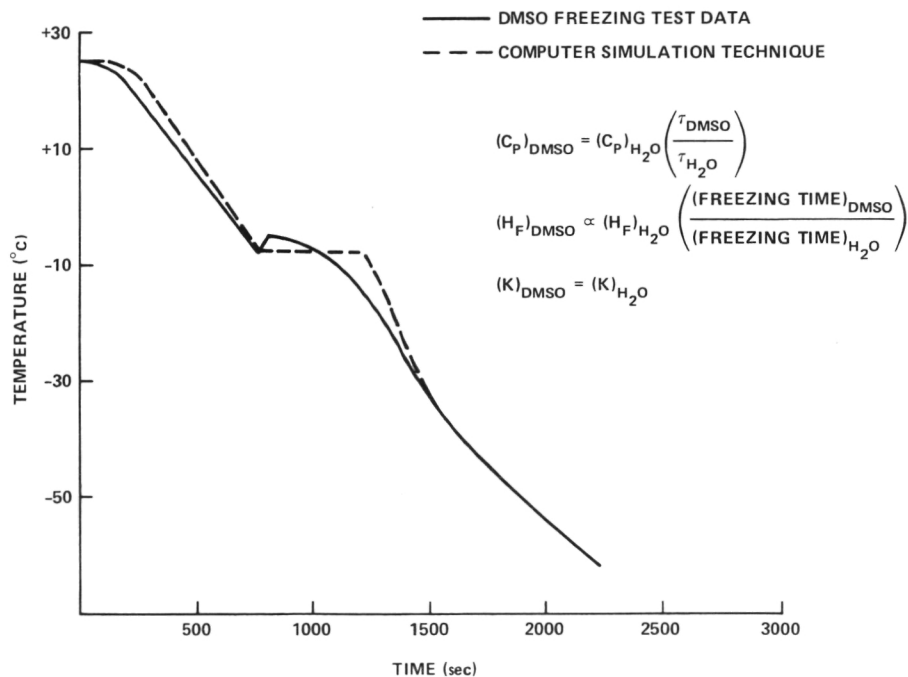

Figure 9. DMSO freezing curve.

Because the optimum freezing process for the white blood cells is unknown, one of the uses of the computer program is to determine a bag-temperature profile that will result in a specified cooling curve at a point within the fluid. It could also be used as a research tool to investigate the effects of different cooling-fluid temperatures on the freezing rate within the solution in the bag. Figure 10 shows the results of an analysis to determine the cooling-gas temperature required for maintaining the bag cooling rate at 2 K per minute. Figure 10 also shows the temperature within the fluid. These data indicate how the fluid temperature compares to the bag temperature.

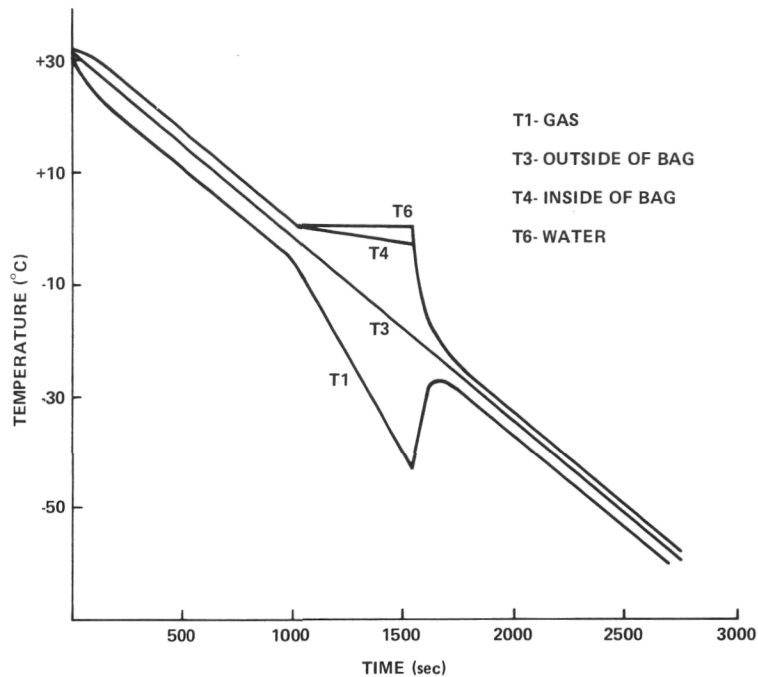

Figure 10. Computer generated freezing curve for water.

SYSTEM DESIGN

Blood-container Assembly

As previously stated, the blood-container assembly consists of a polyethylene bag sandwiched between aluminum plates that have heaters mounted to their exterior surface. This configuration was selected for the following reasons:

- Analyses indicated a need for a thin section to minimize thermal gradients within the blood.
- It was compatible with the standard blood-retainer-bag configuration.
- It provides more easily analyzed and adaptable one-dimensional heat flow.
- It simplifies heater installation.
- It is compatible with the readily available gaseous-nitrogen freezers.

Figure 11 shows the unit used for most of the developmental work. This unit measures 13 by 18 cm and is designed to hold up to 100 milliliters of white blood cells. A larger bag and assembly, now in use at NCI, are described later in this section.

The bag is made of polyethylene with a wall thickness of 0.05 millimeters. Polyethylene is a comparatively good thermal conductor for this type of application. This fact, combined with the thin wall, provides for good thermal conductance. A self-sealing port permits the cells to be injected and withdrawn under sterile conditions. These bags are commercially



Figure 11. Blood container and electronic control unit.

available. The sandwich plates are made of 0.75-mm thick hardened aluminum for good mechanical stiffness and high thermal conductivity. The surface is chemically etched to provide a good bond with the heaters.

The heaters consist of copper-alloy foil sandwiched between two layers of Kapton film. Their total thickness is less than 0.2 millimeters. This design element helps to minimize the thermal-resistance path and to provide fast thermal response because of the small thermal capacity of the heaters. The maximum power requirement for the heaters depends on both the gas-flow rate of the freezer being used and on the maximum desired cooling rate of the blood (4 K/minute). It was experimentally determined that 280 watts would be the maximum power required for this configuration, and the final heaters were selected accordingly.

A hole was drilled through the heater/plate assembly, and a thermocouple was passed through and was permanently mounted on the inside surface of the plate so that it touches the bag.

During the freezing process, the entire assembly is held together at the edges of the aluminum plates by a fiberglass channel. Because the container is mounted vertically (in line with freezer-gas flow), the moderate hydrostatic pressure of the liquid in the bag tends to push the plates apart. The plates are sufficiently stiff to prevent more than negligible bending, and a uniform thickness of the blood sample results.

When the development work on this assembly was complete, NCI expressed a desire to freeze up to 200 milliliters of white blood cells at one time. With the 13- by 18-cm bag, this would have meant increasing the sectional thickness of the blood from about 5 millimeters to 10 millimeters. Because of the thermal resistance of the blood/chemical mixture to heat flow, this was totally undesirable. Consequently, a new blood-container assembly was

designed. A new polyethylene bag measuring 28 by 28 cm was commercially available, and the new assembly was designed to accommodate that bag. To permit sufficient clearance, the plate surface was increased to 30 by 30 cm.

Because of the increased size of the new assembly, the effects of hydrostatic pressures within the bag necessitated that the sandwich assembly be redesigned. Because it was not thermally desirable to increase the thickness of the aluminum plate, the edge-holding technique used in the 13- by 18-cm assembly was no longer adequate. After considering various alternatives, a fiberglass reinforced structure was selected. The plate is supported around its perimeter and at every 4 cm over the entire surface. It was designed to be stiff enough to prevent the thickness of the blood sample from deviating more than 0.02 millimeters from nominal. Figure 12 shows the entire assembly. Specially made aluminum clamps hold the assembly together. Four sets of clamps permit this unit to freeze volumes of 60 to 220 milliliters. With the larger bag, a bigger freezer was used, and the maximum heater power had to be increased to 670 watts. The control system and electronics remained the same as those designed for the 13- by 18-cm bag.

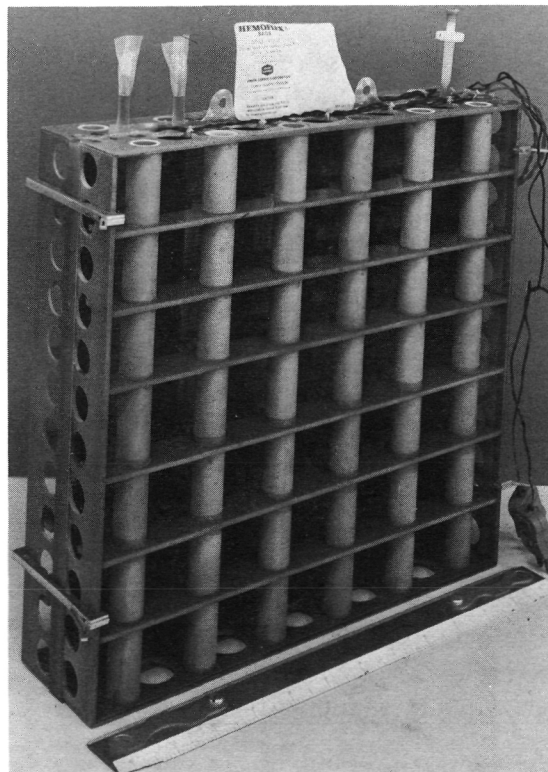

Figure 12. 30- by 30-cm blood container.

Electronics

The purpose of the electronic control unit is to automatically control the power into the heaters and thereby to control the blood temperature. Several types of circuits were considered, and two were tried before the final design was made. Two circuits were rejected:

- A dc-powered pulse-width-modulated circuit had two serious drawbacks. First, because of the large amount of heater power required, a large dc supply was needed, adding considerable weight and cost to the system. Second, switching of the large currents created system noise problems.
- An ac-powered variable phase-angle circuit eliminated the power-supply requirement, but still created too much noise.

These problems were eliminated by using a time-proportioning temperature-control circuit with the following primary characteristics:

- Provides proportional control—output power is proportional to temperature error
- Proportional bandwidth—0.5 K
- Recycling period—500 milliseconds
- Power output—up to 1500 watts continuous
- Remotely programmable
- Relatively few components
- No noise problems attributable to zero-crossing firing

Figures 3 and 11 show the electronics unit, and figure 13 shows the entire schematic. The circuitry can be easily understood by referring to the diagram shown in figure 13. The thermocouple next to the blood bag (TC1) is connected to a semiconductor reference junction that is connected to amplifier A4 and is amplified by 1000. This high-level signal is then provided at TB3 for display on a recorder. The signal is also fed into amplifier A2 where it is compared with the signal from the potentiometer in the bag-temperature programmer. The greater the difference in these signals, the greater the output voltage from A2. This error voltage is fed to one input of a μ a 742 zero-crossing ac trigger. In conjunction with the two-transistor ramp generator, the μ a 742 provides trigger pulses to the RCA 40802 Triac at the zero crossing of the load current when the input error voltage exceeds the level of the ramp generator. The number of output cycles during each 500-millisecond period is proportional to the error voltage. The resultant resolution is 1/60 K with a full power bandwidth of 1/2 K. The circuit is capable of going from zero to full power in 0.5 second.

Thermocouple TC2 and its associated amplifier, A3, is used to measure the freezer-gas temperature. This circuit was added for convenience and has no direct control function.

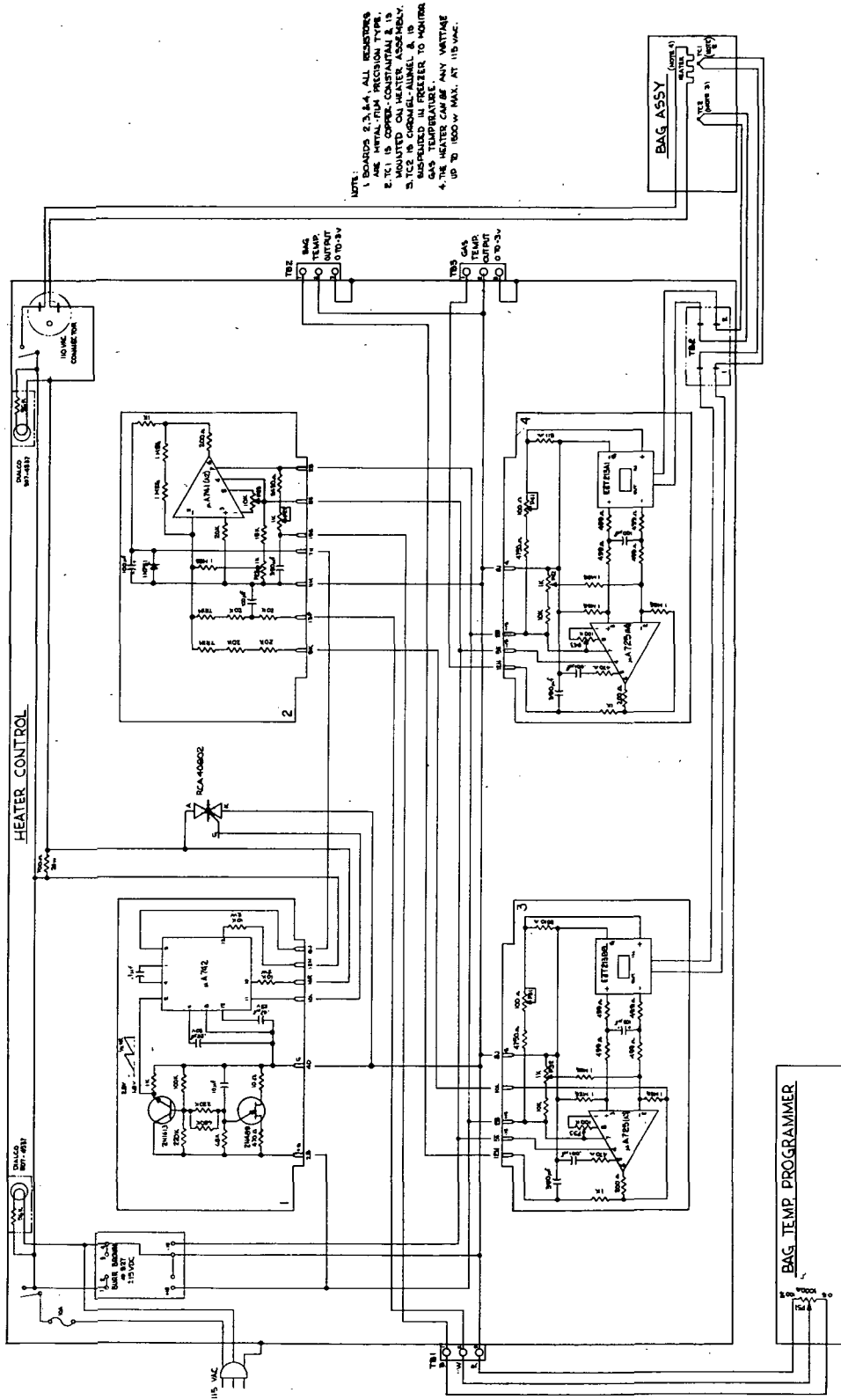

NOTE:
 1. BOARD'S 2, 3, & 4 ALL RESISTORS
 ARE 1/2 WATT 5% TOLERANCE
 2. TE1 IS COPPER-CONSTANTAN & IS
 MOUNTED ON HEATER ASSEMBLY.
 3. TE2 IS CADMIUM-ALUMINUM & IS
 MOUNTED ON HEATER TO MONITOR
 GAS TEMPERATURE.
 4. THE HEATER CAN BE ANY VARIETY
 UP TO 1000 W MAX. AT 115 VAC.

Figure 13. Biological Freezing System, Schematic

Freezer

The freezer used in this system is a commercially available biological cryogenic freezer. These freezers are capable of high cooling rates; they can be quickly recycled back to ambient temperature, and they are easy to operate. The cooling medium is circulated cold-nitrogen gas that is obtained from an external liquid-nitrogen supply. Temperature control is achieved by automatically controlling the flow of nitrogen into the freezing chamber. Temperatures as low as 173 K are readily achieved and maintained.

The primary requirements of the freezer are that it be physically capable of accepting the blood-container assembly and that it be capable of extracting heat from the blood at the maximum rate desired during the freezing process. The nitrogen freezers satisfy these requirements and are also simple to operate and trouble-free.

TEST RESULTS

GSFC conducted extensive tests, using the entire freezing system as shown in figure 3. These tests included various blood quantities up to 100 milliliters, various freezing rates from 1 K per minute to 4 K per minute, and a wide range of combinations of blood-cell/chemical concentrations. The system performed as required during all of these tests. That is, the freezing rate was constant (figure 4) while freezing from 293 to 223 K and was independent of blood volume or concentration.

Because the available freezer was not large enough, GSFC could not test the 30- by 30-cm blood-container assembly before delivering it to NCI. NCI conducted tests at its research facility using various volumes (60 to 220 milliliters) and various blood samples, but at only 1 K per minute. All systems worked very well. No testing was done at the higher freezing rates because NCI research was being done at 1 K per minute and NCI was anxious to get the entire system in service.

CONCLUSIONS

The system described in this document was turned over to the Experimental Hematology Branch (EHB) at the National Cancer Institute for its use in leukemia research and is now fully operational. EHB's current work with the system involves freezing bone marrow and white blood cells from dogs and using it for later transfusions. Since January 1975, many dogs who have had their bone marrow and white blood cells destroyed by radiation have survived because of subsequent transfusions of the previously frozen blood. These results have been encouraging, and more extensive and critical tests are now underway. This system has improved the researchers' procedure and technique and has provided a system adaptable to their research requirements.

The system could conceivably be applied to freezing other biological samples that require a strict control on the freezing rate.

ACKNOWLEDGMENTS

This work was conducted under, and funded by, the NASA Technology Utilization (TU) Program. Donald Friedman and Wayne Chen of the GSFC TU Office assisted in obtaining approval for this program.

Other GSFC personnel who contributed to the computer analyses, laboratory testing, and hardware design include David Olney, Carl Salas, Daniel McHugh, James Largent, and Tazewell Jackson.

Goddard Space Flight Center
National Aeronautics and Space Administration
Greenbelt, Maryland April 1977

SOURCES

- "Controlled Rate of Freezing White Blood Cells," NASA Research and Technology Operating Plan 141-91-01, May 10, 1971.
- Cryoson Technisch Laboratorium, "Cryoson BV-4 Automatic Biological Freezer," a manual, Midden Beemster, Holland.
- Huggens, Charles E., "Experimental and Clinical Aspects of Blood Preservation by Freezing," *Journal of Cryosurgery*, 2 (4), 1969.
- Huggens, Charles E., "Frozen Blood-clinical Experience," *Surgery*, 60 (1), July 1966.
- Huggens, Charles E., "Frozen Blood: Principles of Practical Preservation," *Monographs in the Surgical Sciences*, Williams & Wilkins Co., 3 (3), 1966.
- Huggens, Charles E., "Preservation and Storage of Blood," reprint from Rapaport-Dausset "Human Transplantation," Grune & Stratton, Inc., 1968.
- Meryman, H. T., "Interpretation of Freezing Rates in Biological Materials," *Cryobiology*, 2 (4), 1966.
- Rowe, Arthur W., "Cryogenic Blood Preservation," *Mechanical Engineering*, May 1971.
- Yankee, Ronald, "Method of Controlling Rate of Cooling in Liquids," Report No. NTI/NCI-4, National Cancer Institute, July 1971.

APPENDIX A
EVALUATION OF FREEZING SYSTEM CONCEPTS

APPENDIX A

EVALUATION OF FREEZING SYSTEM CONCEPTS

Before the freezing system design described in the main text of this document was selected, a number of other concepts were considered. In addition to the performance requirements, other factors considered were practicality of fabrication, ease of later system modification, convenience of use, and cost.

Early in the program, a number of tests were conducted with the freezer system that NCI was then using to gain insight into the problems involved and to provide possible ideas for improving the freezing system design. Some shortcomings of that system are described in the following paragraphs.

With all systems considered, before the freezing process began, the cells were mixed with a cryoprotective agent in an ampule or sample bag. Typically, in the procedures previously employed, the container was then placed in a standard biological freezer. The freezer used liquid nitrogen that vaporized to provide cooling gas to which heat was transferred from the sample being frozen. The system was programmed to drop the cooling-gas temperature at a desired rate; i.e., control was maintained over the cooling gas, not the freezing sample (although the temperature of the outside surface of the sample container was monitored and recorded). After the sample was completely frozen, it was quickly transferred to a storage freezer where it was kept until needed.

One significant disadvantage of this technique is that temperature control of the cooling gas was maintained rather than the sample being frozen. Variations in thermal properties and quantity being frozen from one sample to another result in widely varying sample-freezing rates. This is unsatisfactory because existing test data indicate that cell viability is strongly dependent on freezing rate.

Modifications of the foregoing technique could provide some improvement. For example, the temperature of the sample being frozen could be used to control the flow of liquid nitrogen to the freezing chamber. However, freezer-gas temperature response is slow, and a uniform repeatable freezing curve for the sample cannot be maintained.

Another possible modification involves increasing the flow of liquid nitrogen to the freezer chamber when the sample being frozen reaches the freezing point. In reality, the liquid experiences a subcooling effect near the freezing point. The temperature drops below the freezing temperature until freezing begins and rises a few degrees when freezing is initiated. The output of the thermocouple located on the sample indicates when freezing begins. At

this point, the liquid nitrogen can be turned on at full flow to provide maximum cooling. However, the response of the cooling-gas temperature is not fast enough to maintain the required cooling.

Attempts to program the freezer to provide more or less cooling at different phases of the freezing process are unsuccessful because: (1) the time that the phase changes occur can vary from sample to sample, and (2) the freezer cooling gas cannot change temperature quickly enough.

In pursuing an improved design, initial efforts were directed to concepts that use liquid cooling. The first concept considered was that which was proposed by Dr. Ronald Yankee* (figure A-1).

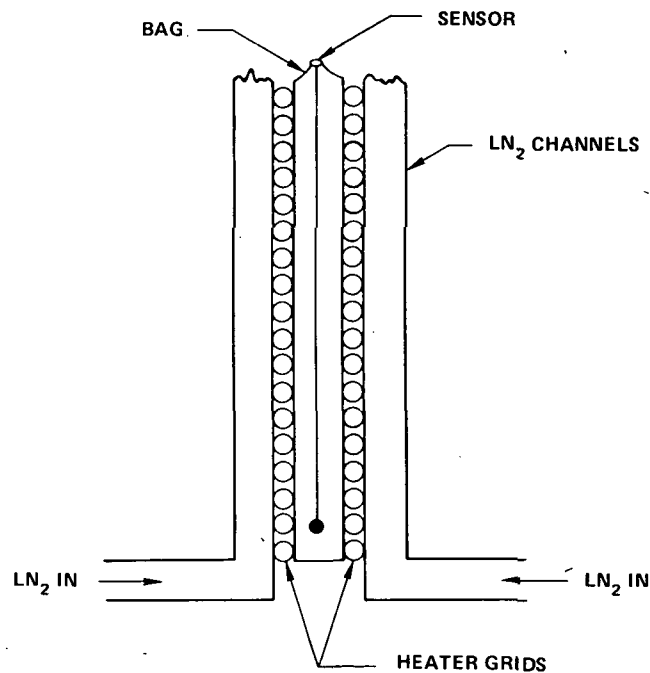

Figure A-1. Concept 1: Freezing system using LN₂ for cooling.

White blood cells in a solution are contained in a bag, and cooling is supplied by the liquid nitrogen flowing through the system. A heater located between the liquid-nitrogen tubes and the bag controls the cooling rate during the cooling of the liquid and solid phases. When the freezing point is reached, heating is discontinued so that a sharp increase in cooling occurs to remove the latent heat of fusion from the liquid. A modified Wheatstone Bridge circuit was proposed for regulating the temperature of the solution being frozen.

*"Method of Controlling Rate of Cooling in Liquids," Dr. Ronald Yankee, Report No. NTI/NCI-4, National Cancer Institute, July 1971.

After some preliminary analysis, it was concluded that the concept shown in figure A-1 is impractical for a number of reasons. First, a prohibitive amount of power would be required to control the cooling rate if the liquid nitrogen flowed continuously. For example, with a 28- by 28-cm single bag, if liquid nitrogen flowed in the channels on only one side of the bag, about 1.5 kilowatts would be required to control the cooling rate. Moreover, a considerable amount of liquid nitrogen would be required.

Freezing from one side of the bag only is undesirable because temperature gradients exist across the thickness of the liquid to be frozen. The liquid is a comparatively poor thermal conductor and, consequently, should be in a thin layer with maximum surface available to the cooling media. It is therefore preferable to clamp the bag between two channels that contain liquid nitrogen. This system would be impractical to fabricate and use conveniently. Moreover, the system would not be easily adaptable to freezing multiple bags of blood, and the heater power would become even more prohibitive.

Another problem with this concept is that some of the design requirements conflict with each other. To control cooling rates with a reasonable heater power, a large thermal impedance and a low thermal capacity is desirable between the liquid nitrogen and the heater. On the other hand, the requirement for "instantaneous" removal of the heat of fusion dictates a minimal thermal impedance between the liquid nitrogen and the blood bag.

The removal of the latent heat of fusion requires some finite time no matter which type of freezing system is used. The various components of the system possess a wide range of thermal properties. During the actual freezing, these components will cool at different rates. It would be very difficult to regain control of the system after the liquid has completely frozen.

Finally, because of the severe temperature differentials and transient variations in the system, it would be difficult to keep the joints leak-free during expansion and contraction.

Figure A-2 depicts a concept that attempts to eliminate some of the shortcomings of the first concept. In this concept, a controlled temperature surface is maintained to act as the heat sink for the cooling of the blood. This surface is separated from the surface on which the heater is mounted by either an insulating material or fins of the same materials as the two surfaces.

The quick-freezing capability would be accomplished by flooding the area in which the fins are located to cool the surface on which the heater is located down to liquid-nitrogen temperature.

Values were estimated for all parameters except for the A_2 , the area of the fins, as follows:

- T_1 173 K
- A_1 280 cm² (14 by 20)

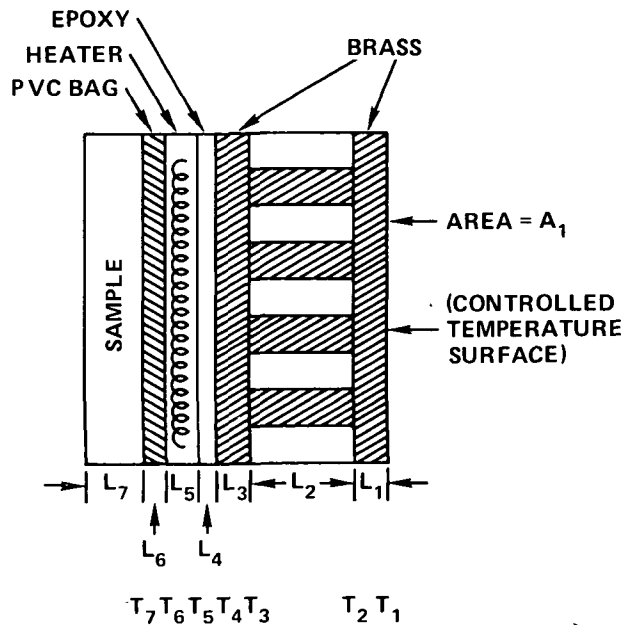

Figure A-2. Concept II: White blood-cell freezing system.

- A_2 To be determined
- L_1 0.1 cm
- L_2 1.3 cm
- L_3 0.025 cm
- L_4 0.025 cm
- L_5 0.09 cm
- L_6 0.038 cm

Assuming that the heater would be at 293 K with the system on when the bag was inserted, and assuming that the heat transfer is the same throughout all parts of the system (i.e., a hold mode), $A_2 = 2.4 \text{ cm}^2$ when the fins are brass, and a maximum of 200 watts is allowed for heater power. This area is too small for practical fabrication.

One method of solving this problem is to use a thermal insulator for the fin material. For example, if a material with a thermal conductivity of 0.01 that of brass were used for the fins, A_2 could be made nearly equal to A_1 . The practicality of fabrication with dissimilar materials is difficult, and high thermal stresses would exist.

A calculation to determine the approximate freezing time possible with the Concept II system (figure A-2) was done by assuming the temperature of the brass nearest the bag to be 77 K while the blood was at 253 K. The fluid was assumed to have the same latent heat of fusion as water. The time was calculated to be 65.8 seconds. With a thinner heater, the freezing time could be reduced by approximately a factor of 3.

A breadboard model of Concept II, in slightly modified form, was fabricated and tested (figure A-3). The temperature-controlled surface was maintained by controlling the flow of nitrogen gas through a cooling coil attached to the surface. The purpose of these tests was to evaluate the proposed design.

Initial tests were conducted by blowing liquid nitrogen through the system while thermocouples monitored the outside temperature. The system held up well mechanically, but the tremendous pressure from the nitrogen gas caused the upper section to “oil-can” considerably.

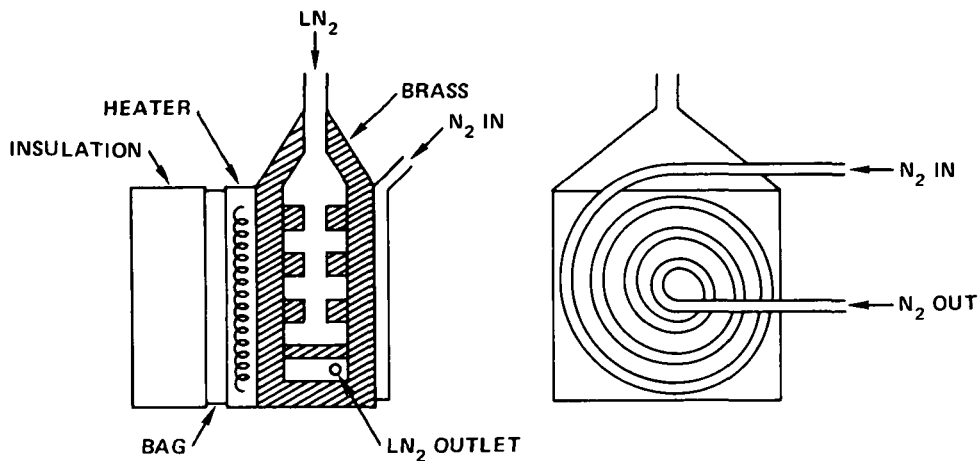

Figure A-3. Breadboard test model of Concept II freezing system.

After the first series of tests, two 80-watt 1-mm thick heaters were epoxyed to the front brass plate. Thermocouples were placed on the heater surfaces and on the back of the brass plate. Attempts were made to maintain a constant temperature of 200 K on the back plate by blowing liquid nitrogen through the coils while keeping the heaters at 296 K. At a given time, the heater was turned off and liquid nitrogen was flooded through the system. Temperatures were again monitored during this test.

Finally, a test was conducted with 100 milliliters of tap water placed in a 10- by 10-cm plastic bag secured to the heaters. With the 100 milliliters of liquid, the bag was about 0.65 cm wide. Thermocouples were placed in the water, on the heater, and on the back of the system. Again, attempts were made to initially maintain constant temperatures of 200 K and 296 K on the back of the plate and in the water, respectively. At a given time, both the cooling of the back plate and the power to the heater were halted, and liquid nitrogen was flooded through the coils. The data and observations from these tests indicated three weaknesses in the proposed design:

1. The cooling ability was below expectations, with a minimum average temperature on the outer plate leveling off at 145 K.

2. The pressure from the nitrogen gas was so great that, by the end of the series of tests, there was evidence of broken connections between the front plate and the upper fins.
3. Adequate temperature control was found to be impossible; during the final test, all attempts to hold the water at 296 K and the back plate at 200 K failed.

At this point, it was concluded that a gaseous cooling system offered the best solution. The plan pursued was to use the basic type of cooling system then in use at NCI. Efforts were then directed at improving the general system by:

- Using improved control techniques
- Obtaining a bag (used to hold the blood) with better thermal properties
- Designing a better bag holder
- Optimizing the cooling rates
- Placing the control thermocouple in a more optimum location

These efforts resulted in the system described in the main text of this document. The new system is better than the system previously used by NCI because:

- The temperature at the surface of the container that holds the sample to be frozen is precisely controlled.
- The cooling gas is lowered to a level below that required at any time other than when latent heat is to be removed. When the high cooling rate is not needed, a heater on the container provides heat to compensate for the excessive cooling capacity. When the latent heat is being removed, the high cooling rate is immediately available by turning off the heater.

APPENDIX B
COMPUTER PROGRAM LISTING

APPENDIX B
COMPUTER PROGRAM LISTING

```

-JOB
-FORTRAN LS,GO
C
C *****
C * DIMENSION STATEMENTS *
C *****
C
  DIMENSION RHO(20),CP(20),COND(20),X(20)
  DIMENSION R(20) , C (20), CM(20)
  DIMENSION A1(20),A2(20),A3(20)
  DIMENSION T(20),TF(20),theta(20),K(20)
C
C *****
C * READ PROGRAM CONSTANTS *
C *****
C
  TAU = INITIAL TIME, TAUM = FINAL TIME, DTAU = TIME INCREMENT, TAUPR = PRINT
  INCREMENT, TAUPU = PUNCH INCREMENT
  TSS = STEADY STATE TEMPERATURE (INITIAL), FT = FREEZING TEMPERATURE
  AA, BB, AND CC ARE INPUT TEMPERATURE CONTROL PARAMETERS
  M = NUMBER OF NODES, NL = NUMBER OF MATERIAL LAYERS, NOHTC INDICATES IF HTC
  VALUE IS TO BE USED, ( 0 IF YES , 1 IF HTC EQUALS INFINITY)
  HTC = HEAT TRANSFER COEFFICIENT, HF = HEAT OF FUSION, AR = CROSS SECTIONAL
  AREA
C
C
  READ 1, TAU, TAUM, DTAU, TAUPR
  PRINT 1, TAU, TAUM, DTAU, TAUPR
  READ 2, TSS, FT, AA, BB
  PRINT 2, TSS, FT, AA, BB
  READ 3, M, NL
  PRINT 3, M, NL
  READ 4, HF, AR
  PRINT 4, HF, AR
  MM=1+M
  NL1 = NL + 1
  NL2 = NL + 2
  NL3 = NL + 3
C
C *****
C * READ MATERIAL PROPERTIES *
C *****
C
  DENSITY, SPECIFIC HEAT, THERMAL CONDUCTIVITY, LENGTH, HEAT GENERATED
C

```



```

      DO 70 I=1,NL2
      READ 5, RHO(I), CP(I), COND(I), X(I)
      PRINT 5, RHO(I), CP(I), COND(I), X(I)
70 CONTINUE
C
C *****
C * SET INITIAL CONDITIONS *
C *****
C
      TAUA = TAU
      M1 = M + 1
      MB = M-NL2
      X(NL1) = X(NL1)/MB
      DO 80 N= 2,MM
80 T(N)=TSS
      DO 90 N=NL3,M1
      Q(N) = 0.0
      K(N) = 0
      R(N) = RHO(NL1)
      C(N) = CP(NL1)
90 CN(N) = COND(NL1)
      CN(M1) = 0.0
      R(4)=R(4)*1.5
C
C *****
C * COMPUTE MATERIAL TEMPERATURE COEFFICIENTS *
C *****
      A1(NL2) = COND(NL)/(RHO(NL)*CP(NL)*(X(NL)/2.)*X(NL))
      F = HF*RHO(NL1)*X(NL1)*AR
C
110 A2(NL2) = CN(NL3)/ (RHO(NL)*CP(NL)*(X(NL)/2.0)*X(NL1))
C
C *****
C * COMPUTE INPUT TEMPERATURE AS A FUNCTION OF TIME *
C *****
C
119 T(1) = AA + BB*TAU
      T(2)=T(1)
C
C *****
C * COMPUTE TEMPERATURES IN THE MATERIALS *
C *****
C
      N=3
      TF(N) = DTAU*A1(N)*T(N-1) + (1.-DTAU*(A1(N) +A2(N)))*T(N) + DTAU*

```

```

1A2(N)*T(N+1)
130 N = N+1
    IF(K(N)-1) 500,700,900
C
C *****
C * NODE NOT FROZEN *
C *****
C
500 B1 =CN(N)/(C(N)*R(N)*X(NL1)**2)
    B2 = CN(N+1)/(C(N)*R(N)*X(NL1)**2)
    TF(N) = DTAU*B1*T(N-1) + (1.-DTAU*(B1+B2))*T(N) + DTAU*B2*T(N+1)
    IF(TF(N)-FT) 550,550,1000
550 K(N) = 1
    PRINT 88
    TF(N) = FT
    GO TO 1000
C
C *****
C * NODE IS NOW FREEZING *
C *****
C
700 TF(N) = FT
    QA = DTAU*AR/X(NL1)* (CN(N)' * (T(N)-T(N-1))-CN(N+1) * (T(N+1)-T(N)
1))
    Q(N) = Q(N)+QA
    R(N) = RHO(NL1)*(1.0-Q(N)/F)+Q(N)/F*RHO(NL2)
    R(4)=(RHO(NL1)*(1.0-Q(4)/F)+Q(4)/F*RHO(NL2))*1.5
    C(N) = CP(NL1)* (1.0-Q(N)/F) + Q(N)/F*CP(NL2)
    CN(N) = COND(NL1)*(1.0-Q(N)/F) + Q(N)/F*COND(NL2)
    IF(Q(N)/F-1.) 1000,750,750
750 K(N) = 2
    GO TO 1000
C
C *****
C * NODE HAS NOW BEEN FROZEN *
C *****
C
900 B1 = CN(N)/(C(N)*R(N)*X(NL1)**2)
    B2 = CN(N+1)/(C(N)*R(N)*X(NL1)**2)
    TF(N) = DTAU*B1*T(N-1) + (1.-DTAU*(B1+B2))*T(N) + DTAU*B2*T(N+1)
C
1000 IF(N-M) 130,1010,1010
C
C *****
C * 'STEP UP' TEMPERATURES AND TIME *

```

```

C *****
1010 DO 1020 N=3,M
1020 T(N) = TF(N)
      T(MM)=T(M-1)
      TAU = TAU+ DTAU
C
C *****
C * OUTPUT STATEMENTS *
C *****
1030 IF(TAU-TAUA)1060,1030,1030
CONTINUE
PRINT 7, (T(N), N=1,M)
PRINT 7, TAU
TAUA = TAUA + TAUPR
C
C
1060 IF(TAU-TAUM) 110,1200,1200
1200 CONTINUE
C
C *****
C * FORMAT STATEMENTS *
C *****
C
1 FORMAT(4(F15.7))
2 FORMAT(2(F10.3,5X),5X,2(F15.7))
3 FORMAT(2I10)
4 FORMAT(2(F15.7,5X))
5 FORMAT(4(F15.7))
6 FORMAT(/,F10.3,/)
7 FORMAT(10(F10.3,3X))
88 FORMAT(/,1H*)
END
-LOAD X
-DATE
0.0          3000.          .01          60.
6.0          0.0          6.00          -.016667
  6          1
79.71          1.0
.925          .55          .000785          .0254
1.0          1.0          .0014          .1255
1.0          .44          .004          .1255
-FIN

```

0177 CARDS

APPENDIX C
CONTAINER DRAWINGS

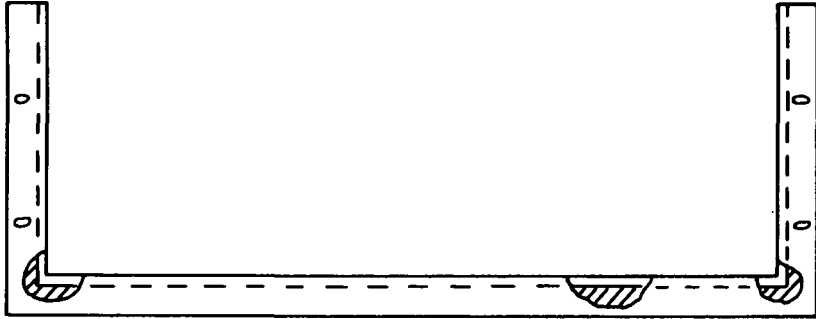
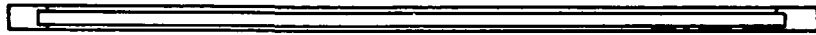

(a) FRAME

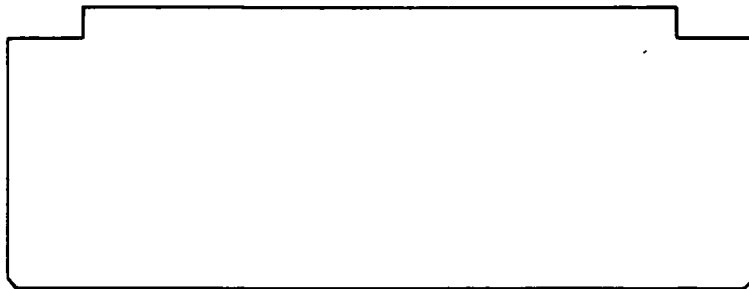

(b) PLATE

Figure C-1. Bio-pack (5 by 15 cm).

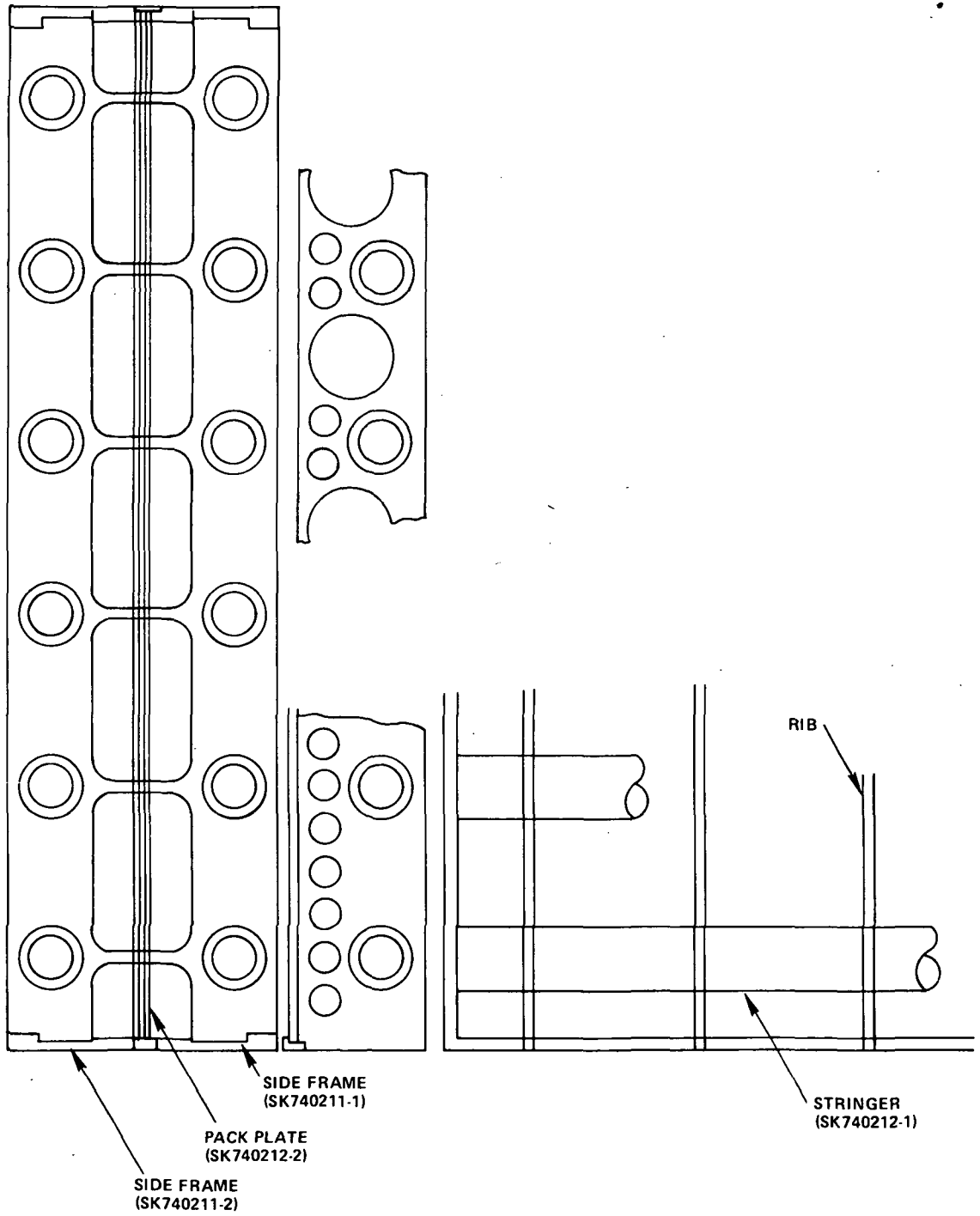

Figure C-2. Bio-pack structure (30 by 30 cm).

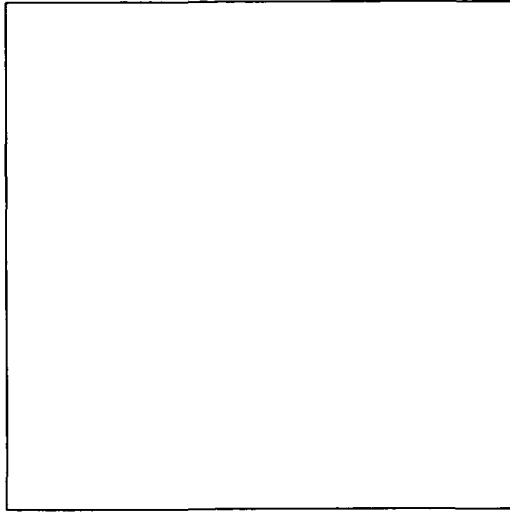

Figure C-3. Bio-pack plate.

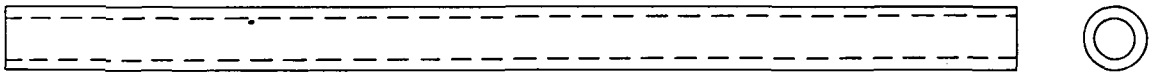

Figure C-4. Bio-pack stringer.

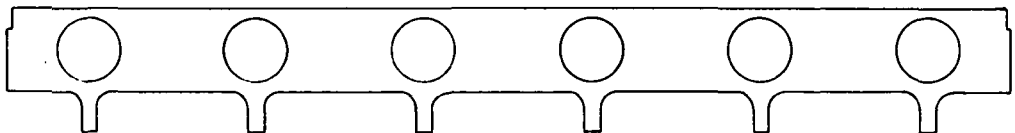
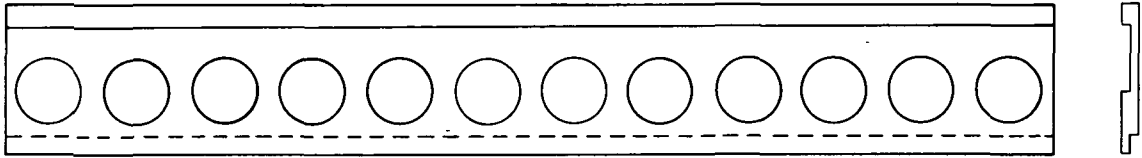
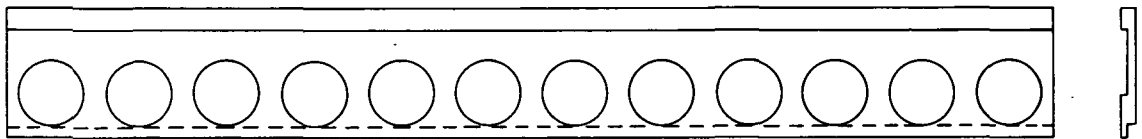

Figure C-5. Bio-pack main rib.



(a) SK740211-2



(b) SK740211-1

Figure C-6. Bio-pack side frames.

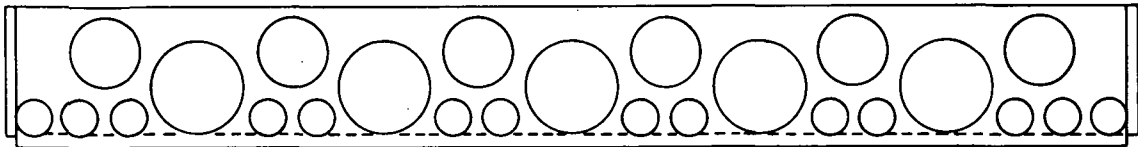

(a) UPPER

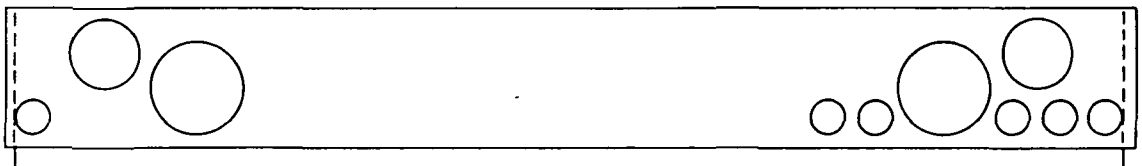

(b) LOWER

Figure C-7. Bio-pack end frames.

1. Report No. NASA TP-1165	2. Government Accession No.	3. Recipient's Catalog No.	
4. Title and Subtitle Design of a Blood-Freezing System for Leukemia Research		5. Report Date February 1978	6. Performing Organization Code 713
		8. Performing Organization Report No. G7702-F9	
7. Author(s) Thomas E. Williams and Thomas A. Cygnarowicz		10. Work Unit No.	
9. Performing Organization Name and Address Goddard Space Flight Center Greenbelt, Maryland 20771		11. Contract or Grant No.	
		13. Type of Report and Period Covered Technical Paper	
12. Sponsoring Agency Name and Address National Aeronautics and Space Administration Washington, D.C. 20546		14. Sponsoring Agency Code	
		15. Supplementary Notes	
16. Abstract Current leukemia research involves the use of cryogenic freezing and storage equipment. In a program being carried out at the National Cancer Institute (NCI), bone marrow (white blood cells) has been frozen using a standard cryogenic biological freezer. With this system, it is difficult to maintain the desired rate of freezing and repeatability from sample to sample. A freezing system has now been developed at the National Aeronautics and Space Administration/Goddard Space Flight Center under its Technology Utilization (TU) Program that satisfies the requirements for a repeatable, constant freezing rate. The system has been delivered to NCI and is now operational. This report describes the design of the major sub-systems, the analyses, the operating procedure, and final system test results.			
17. Key Words (Selected by Author(s)) Blood, Cryogenics, Freezing, Hematology, Leukemias		18. Distribution Statement STAR Category 51 Unclassified—Unlimited	
19. Security Classif. (of this report) Unclassified	20. Security Classif. (of this page) Unclassified	21. No. of Pages 44	22. Price* \$4.50

*For sale by the National Technical Information Service, Springfield, Virginia 22161

NASA-Langley, 1978

National Aeronautics and
Space Administration

THIRD-CLASS BULK RATE

Postage and Fees Paid
National Aeronautics and
Space Administration
NASA-451



Washington, D.C.
20546

Official Business

Penalty for Private Use, \$300

NASA

POSTMASTER: If Undeliverable (Section 158
Postal Manual) Do Not Return
