

DRA

AEROSPACE REPORT NO.
ATR-78(7642)-1

User's Guide to Data Obtained by The Aerospace Corporation Energetic Particle Spectrometer on ATS-6

Prepared by G. A. PAULIKAS and H. H. HILTON
Space Sciences Laboratory

(NASA-CR-155950)	USER'S GUIDE TO DATA	N78-19193
OBTAINED BY THE AEROSPACE CORPORATION		
ENERGETIC PARTICLE SPECTROMETER ON ATS-6		
(Aerospace Corp., El Segundo, Calif.)	120 p	Unclas
HC A06/MF A01	CSSL 14B G3/19	15203

3 October 1977

Prepared for
NASA GODDARD SPACE FLIGHT CENTER
Greenbelt, Maryland 20771

Contract No. NAS5-23788



The Ivan A. Getting Laboratories
THE AEROSPACE CORPORATION

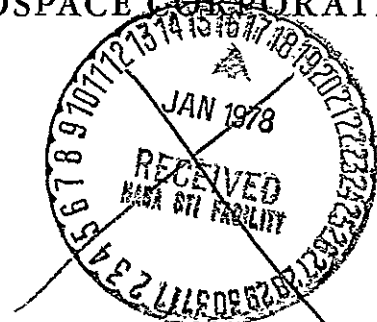

THE IVAN A. GETTING LABORATORIES

The Laboratory Operations of The Aerospace Corporation is conducting experimental and theoretical investigations necessary for the evaluation and application of scientific advances to new military concepts and systems. Versatility and flexibility have been developed to a high degree by the laboratory personnel in dealing with the many problems encountered in the nation's rapidly developing space and missile systems. Expertise in the latest scientific developments is vital to the accomplishment of tasks related to these problems. The laboratories that contribute to this research are:

Aerophysics Laboratory: Launch and reentry aerodynamics, heat transfer, reentry physics, chemical kinetics, structural mechanics, flight dynamics, atmospheric pollution, and high-power gas lasers.

Chemistry and Physics Laboratory: Atmospheric reactions and atmospheric optics, chemical reactions in polluted atmospheres, chemical reactions of excited species in rocket plumes, chemical thermodynamics, plasma and laser-induced reactions, laser chemistry, propulsion chemistry, space vacuum and radiation effects on materials, lubrication and surface phenomena, photosensitive materials and sensors, high precision laser ranging, and the application of physics and chemistry to problems of law enforcement and biomedicine.

Electronics Research Laboratory: Electromagnetic theory, devices, and propagation phenomena, including plasma electromagnetics; quantum electronics, lasers, and electro-optics; communication sciences, applied electronics, semiconducting, superconducting, and crystal device physics, optical and acoustical imaging; atmospheric pollution; millimeter wave and far-infrared technology.

Materials Sciences Laboratory: Development of new materials; metal matrix composites and new forms of carbon; test and evaluation of graphite and ceramics in reentry; spacecraft materials and electronic components in nuclear weapons environment; application of fracture mechanics to stress corrosion and fatigue-induced fractures in structural metals.

Space Sciences Laboratory: Atmospheric and ionospheric physics, radiation from the atmosphere, density and composition of the atmosphere, aurorae and airglow; magnetospheric physics, cosmic rays, generation and propagation of plasma waves in the magnetosphere; solar physics, studies of solar magnetic fields; space astronomy, x-ray astronomy; the effects of nuclear explosions, magnetic storms, and solar activity on the earth's atmosphere, ionosphere, and magnetosphere; the effects of optical, electromagnetic, and particulate radiations in space on space systems.

THE AEROSPACE CORPORATION
El Segundo, California

. . .

Aerospace Report No.
ATR-78(7642)-1

USER'S GUIDE TO DATA OBTAINED BY
THE AEROSPACE CORPORATION ENERGETIC
PARTICLE SPECTROMETER ON ATS-6

Prepared by
G. A. Paulikas and H. H. Hilton
Space Sciences Laboratory

3 October 1977

The Ivan A. Getting Laboratories
THE AEROSPACE CORPORATION
El Segundo, California 90245

Contract No. NAS5-23788

Prepared for
NASA GODDARD SPACE FLIGHT CENTER
Greenbelt, Maryland 20771

USER'S GUIDE TO DATA OBTAINED BY
THE AEROSPACE CORPORATION ENERGETIC
PARTICLE SPECTROMETER ON ATS-6

Prepared



G. A. Paulikas, Director
Space Sciences Laboratory

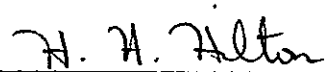

H. H. Hilton
Senior Staff Scientist

Approved

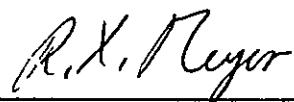

for G. W. King
Vice President and General
Manager
The Ivan A. Getting Laboratories

ABSTRACT

This report is the user's guide to the data obtained by the ATS-6 Aerospace Corporation energetic particle detector and deposited at the National Space Science Data Center. Contained are descriptions of the instrument, calibration data, information on instrumental and operational anomalies and a description of the procedures used to reduce the data. A description of the format of the data is also presented.

CONTENTS

ABSTRACT	v
I. EXPERIMENT DESCRIPTION	1
II. OPERATIONAL, INSTRUMENTAL AND DATA ANOMALIES	9
A. Instrumental Anomalies	9
B. Operational Anomalies	9
C. Data Anomalies	10
III. DESCRIPTION OF DATA	13
A. Aerospace Corporation Experimental Tapes	13
B. Data Reduction and Processing	13
C. The Data Tape Formats	15
IV. DATA CATALOG	37
V. REPRINTS	65

I. EXPERIMENT
DESCRIPTION

ATS-6 Energetic Particle Radiation Measurement at Synchronous Altitude

G. A. PAULIKAS
J. B. BLAKE
S. S. IMAMOTO
Space Physics Laboratory
The Aerospace Corporation
El Segundo, Calif. 90245

Abstract

The Aerospace Corporation energetic electron proton spectrometer operating on Applications Technology Satellite-6 (ATS-6) detects energetic electrons in four channels between 140 keV and greater than 3.9 MeV, and measures energetic protons in five energy channels between 2.3 and 80 MeV and energetic alpha particles in three channels between 9.4 and 94 MeV. After more than a year of operation in orbit, the experiment continues to return excellent data on the behavior of energetic magnetospheric electrons as well as information regarding the fluxes of solar protons and alpha particles.

Manuscript received August 1, 1975. Copyright 1975 by IEEE
Trans. Aerospace and Electronic Systems, vol. AES-11, no. 6,
November 1975.

This work was supported in part by the U. S. Air Force Space and Missile Systems Organization, under Contract F04701-74-C-0075, and in part by the National Aeronautics and Space Administration, under Contract NASW-2762.

I. Introduction

The region of space near the synchronous altitude is a fascinating part of space where various domains of the magnetosphere meet and interact. Fig. 1, taken from Frank [1], graphically illustrates the confluence of the plasma-pause, the extraterrestrial ring current, the boundary of the zone of energetic particles, and the Earthward terminus of the plasma sheet in the immediate vicinity of $6.6 R_e$. The study of the interaction of the various plasmas with vastly different densities and temperatures and the energization and dynamics of these plasmas are the goals of the Environmental Measurements Experiments (EME) on Applications Technology Satellite-6 (ATS-6).

The aerospace experiment described in this paper contributes to these goals through measurements of the high energy tail of the electron distribution function. The experiment covers the energy range for electrons from 140 keV to greater than 3.9 MeV, and the experiment is expected to yield important results regarding the acceleration and dynamics of the energetic electrons. While previous measurements (see the compilations [8] and [9]) have contributed a great deal of information regarding the behavior of energetic electrons at the synchronous altitude, comprehensive measurements such as those being made on ATS-6 of the entire distribution function for a given particle species have never been made.

Not shown in Fig. 1, but also present in this region of space during solar particle events, are energetic protons and alpha particles (and possibly electrons) of solar origin. These solar particles may penetrate to altitudes as low as $4 R_e$ (depending on particle rigidity and magnetic activity) but, in general, the gradient of solar protons is located somewhere in the vicinity of $6.6 R_e$. The experiment measures the fluxes and spectra of solar particles reaching the synchronous orbit. (The proton thresholds of this experiment are too high to permit the detection of the proton component of the trapped radiation.)

II. Description of the Experiment

A. Physical and Electronic Configuration

The instrument consists of four separate sensors, one two-detector element telescope and three omnidirectional single-detector units. An overall view of the instrument is presented in Fig. 2, and a functional schematic of the electronics is presented in Fig. 3.

The counter telescope uses silicon surface-barrier detectors of ORTEC manufacture behind a disk-loaded collimator. The first detector is 50 mm^2 in area and $230 \mu\text{m}$ deep and the second detector is 200 mm^2 in area and $100 \mu\text{m}$ deep. Both are totally depleted. Five electronic discriminator levels are used with the first detector. The two upper levels are set above the maximum energy a proton can deposit in the detector and thus are sensitive to alphas only (actually $Z \geq 2$). The next two levels are sensitive to protons (actually all ions) but not electrons, and the lowest

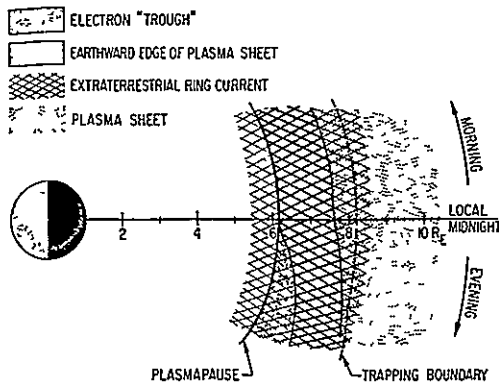

Fig 1 Spatial relationships near the synchronous orbit at local midnight between the ring current, the plasmopause, the energetic particle trapping boundary, and the Earthward terminus of the plasma sheet. This figure is qualitative and representative of magnetic quiet (from Frank [1])

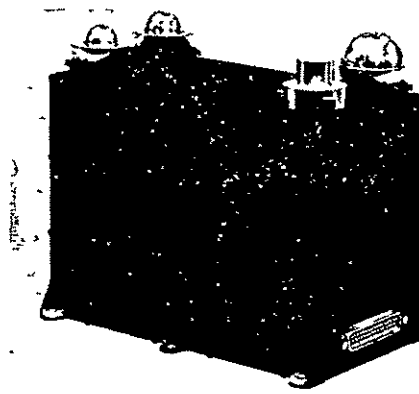

Fig 2 Overall view of the energetic particle spectrometer on ATS-6. Directional detectors are housed inside the cylindrical collimator structure in the foreground.

level is sensitive to all particles in the appropriate energy range. The sole function of the second detector is to inhibit from analysis any penetrating particles. Section IIB provides details about the energy channels.

The three omnidirectional sensors use small cubical lithium-drifted silicon detectors centered under a hemispherical shell and heavily shielded (relative to the hemispherical shield) over the rear 2π solid angle. Protons are separated unambiguously from electrons by setting the second discriminator level well above the maximum energy an electron can deposit in the small semiconductor detector. The fact that dE/dx (energy loss per unit path length) is much greater for protons than for electrons (in the energy range of geophysical interest) is utilized. The absence of electron contamination in the proton channels was verified by electron irradiation of the sensors. The proton threshold of each of the three sensors was determined primarily by the thickness of the hemispherical shield, with the energy threshold of the two most lightly shielded units somewhat affected by the electronic thresholds as well. The most lightly shielded omnidirectional sensor has a third electronic level set above the maximum proton energy deposit to provide an alpha particle channel. The two heavier hemispherical shields were made of beryllium to minimize Bremsstrahlung and maximize the threshold sharpness. The most lightly shielded shield is aluminum since an aluminum shield is much cheaper and the performance difference negligible for such a thin shield.

The electronic subsystem of the experiment is shown schematically in Fig 3. The input stage of the preamps utilize an n-channel field-effect transistor. In order to maintain a low system noise, the input stage is enclosed in a shielded compartment. The characteristic long-tail pulse from the preamplifier is shaped by a pole-zero shaping network into a pulse with a $1\text{-}\mu\text{s}$ time constant. The high level discriminators (greater than 8 MeV) are driven directly from the output of the shaping circuit. Output from the shaping network is also coupled to an operational amplifier which provides the additional gain required to trigger the

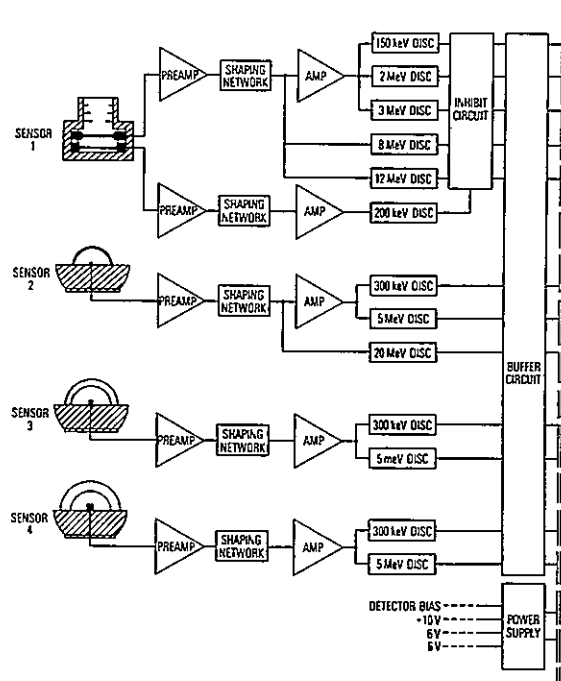

Fig 3 Schematic block diagram of detector/electronic system

low energy thresholds. Preamplifier gain is set by an adjustable feedback capacitor. Gain of the operation amplifier is set by a feedback resistor.

The discriminator is essentially a comparator driving a tunnel diode. The threshold voltage is set by a lab-set resistor. Output from the discriminator is a 0-5-V pulse with an approximate duration of a microsecond. A COS/MOS buffer circuit accepts the 0-5-V discriminator pulse and provides a 0-10-V pulse to interface with the spacecraft encoder.

Sensor 1 uses two sets of circuits identical to those used for sensors 2, 3, and 4. The front detector of the two-detector array has five discriminators which drive an inhibit circuit, particles penetrating through the first detector are

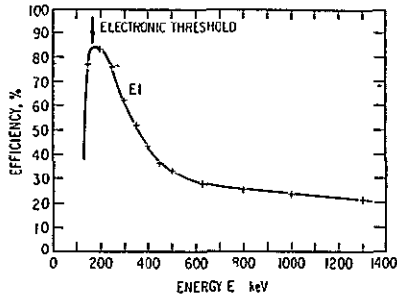

Fig 4 Efficiency of detection of electrons in the E1 channel This channel has a nominal energy sensitivity of 140-600 keV Sensitivity of this channel below the nominal electronic threshold is associated with the finite noise of the detector

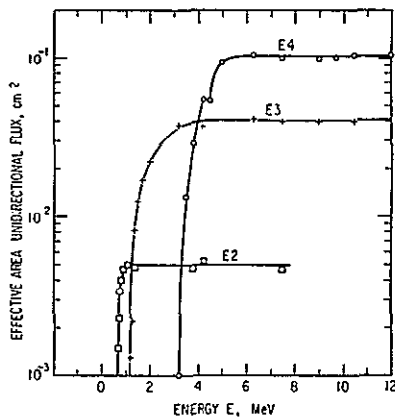

Fig 5 Effective area of the E2, E3, and E4 electron channels as a function of electron energy This effective area, when integrated over the angular response of the detector, yields the omnidirectional geometric factor

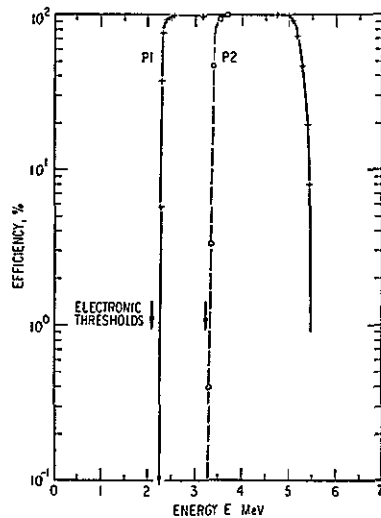

Fig 6 Efficiency for detection of protons in the P1 and P2 channels of the counter telescope

Table I

Channel	Passband or Threshold (MeV)	ϵG
E1	0.140 - 0.600	$115 \text{ cm}^2 \cdot \text{sr}$
E2	0.700	0.0349 cm^2
E3	1.55	0.176 cm^2
E4	3.90	0.688 cm^2

thus rejected COS/MOS logic is used to perform the trailing edge logic in the inhibit circuit Trailing edge logic is used to compensate for "walk" in the discriminators Outputs from the inhibit circuit are also buffered to interface with the encoder

A DC-DC converter provides the required instrument bias voltages Power from the spacecraft is coupled to a series pass stage to limit the experiment turn on transient and to protect spacecraft relays The converter section is completely enclosed in an electrostatic shield to minimize undesirable pickup by the counting circuits Total power consumption is 475-540 mW, depending on the count rate at which the instrument is operating

Terminal boards with discrete components and point-to-point wiring are used in the construction of the amplifiers, discriminators, and power supply Printed circuit and integrated circuits are used for the inhibit and buffer circuits Total experiment weight is 1.2 kg

B. Detector Calibration Data

1) *Electron Channels* Figs 4 and 5 display the electron calibration data in graphical form The E1 channel employs a directional geometry of $1.6 \times 10^{-1} \text{ cm}^2 \cdot \text{sr}$, the E2, E3, and E4 channels used on omnidirectional geometry and thus the calibration data, obtained with a plane parallel beam, must be integrated over the angular acceptance of these detectors in order to arrive at the omnidirectional efficiency as a function of energy However, it is convenient to define thresholds and geometric factors for obtaining rapid estimates of fluxes These thresholds and geometric factors are calculated by numerically integrating the response function over various spectral shapes and finding the threshold which minimizes the variation of the calculated geometric with spectral shape The results are given in Table I

The proton and alpha particle channels have negligible sensitivity to electrons.

2) *Proton Channels* The proton calibration data for channels P1 and P2 are shown in Fig. 6 The thresholds of these two channels are sharp enough $[\Delta E/E_{\text{threshold}} \ll 1]$, where $\Delta E \sim E (\epsilon = 90 \text{ percent}) - E (\epsilon = 10 \text{ percent})$ to eliminate the need for numerically integrating over the response function The geometric factors of the other proton channels (the omnidirectional sensors) were computed and spot checked at several energies where accelera-

tor protons were available. Table II gives the results. Unfortunately, ATS-6 weight constraints prevented the use of sufficient back shielding to render back penetration negligible for all proton spectra. Two different thicknesses of shielding covered the rear hemisphere and thus each channel has three passbands and geometric-factors. These "rear passbands" are also given in Table II.

In all cases the electron channels are sensitive to protons. However, as a general rule, at the synchronous orbit the electron fluxes far exceed those of the trapped protons. Under unusual conditions, i.e., during solar proton events apparent electron counts can be due to protons. The efficiencies of the electron channels for protons are given in Table III.

The proton channels can be triggered by alphas (or higher Z particles), the relative abundance of alphas to protons renders this contamination negligible.

III Operational History

The experiment on ATS-6 was first powered in orbit on June 14, 1974, and has been operating almost continuously since that time, such brief shutdowns of the experiment as have occurred have been associated with tests of other experiments on ATS-6. Several minor anomalies in the performance of the experiment have been observed during the first year of operation. None of these affect the quality of utility of the data in any significant way and all goals of the experiment are being met.

IV Preliminary Results

This brief summary of the preliminary results already obtained from the ATS-6 experiment is an indication of some of the unique contributions ATS-6 data will make to our understanding of the behavior of the magnetosphere and the entry and motion of solar particles in the magnetosphere.

A Energetic Electrons

The first data on energetic electrons obtained by ATS-6 showed that the electron fluxes were much more dynamic than earlier observations [5]-[7] on ATS-1 had indicated. ATS-6 data indicated the virtual disappearance of energetic electrons during portions of the orbit in the nighttime quadrant. Such "dropouts" were observed only rarely on ATS-1. In order to make a quantitative check on this impression, data were obtained from the experiment from ATS-1 for the same time period for a direct comparison of ATS-6 and ATS-1 energetic electron observations. These comparisons are shown in Figs 7 and 8. Fig 7 illustrates observations made during a magnetically quiet period (day 201) which was preceded by three days of magnetic quiet. In general, ATS-6 and ATS-1 energetic electron count rates

Table II

Channel	Energy (MeV)	G	Particle
P1	2.3-5.3	160 cm ² -sr	p
P2	3.4-5.3	160 cm ² -sr	p
P3	9.4-21.2	.160 cm ² -sr	α
P8	13.4-21.2	.160 cm ² -sr	α
P4	12-26	0045 cm ²	p
P5	46-100	0048 cm ²	α
P6	20-52	0188 cm ²	p
P7	40-90	0412 cm ²	p
Rear Passbands			
P4a	58-68	0023 cm ²	p
P4b	85-96	0017 cm ²	p
P5a	232-265	0033 cm ²	α
P5b	344-370	0031 cm ²	α
P6a	58-86	0135 cm ²	p
P6b	86-109	0128 cm ²	p
P7a	58-108	0368 cm ²	p
P7b	86-132	.0318 cm ²	p

Table III

Channel	Energy (MeV)	G	Particle
E1	*see footnote	16 cm ² -sr	p
E2	12-190	0074 cm ²	p
E3	21-290	0287 cm ²	p
E4	40-520	0617 cm ²	p
Rear Passbands			
E2a	58-310	0061 cm ²	p
E2b	86-330	0057 cm ²	p
E3a	58-470	0260 cm ²	p
E3b	86-490	0244 cm ²	p
E4a	58-550	0595 cm ²	p
E4b	86-650	0565 cm ²	p

*The E1 electron channel is sensitive to protons with energies greater than 710 keV. The upper limit of sensitivity is of the order 190 MeV without the veto trigger, about 5.3 MeV when the particle enters, in such a way as to hit the veto detector.

show similar behavior. The sharp decreases in flux near 0430 UT and 0630 UT visible in the ATS-6 data are the results of substorms. Note that the effects of substorms on the energetic electrons are much attenuated at ATS-1 as compared with ATS-6.

During geomagnetically active periods, there is a substantial difference in the count rates observed by the two spacecraft. Fig 8 illustrates a comparison of observations made at ATS-6 and ATS-1 during a disturbed period. Note the total disappearance of flux at ATS-6 while ATS-1 always observes finite fluxes.

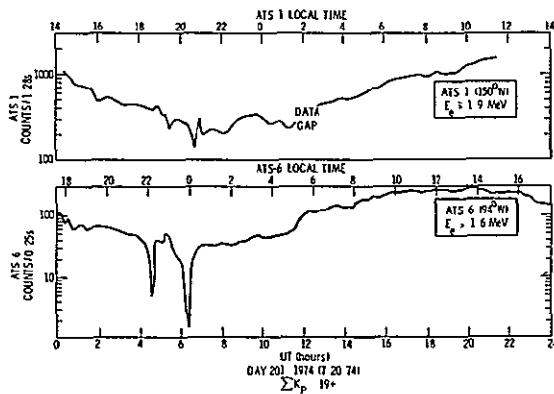

Fig 7 Comparison of energetic electron count rates observed by ATS-6 and ATS-1 during a magnetically quiet day (day 201). The three days preceding day 201 were also quiet.

The differences in phenomenology appear to be due to the different magnetic latitudes of the spacecraft. ATS-6 is located at about 10° magnetic latitude at its location of 94° W longitude, while ATS-1 is almost exactly on the magnetic equator at 150° W. The approximately 10° difference in magnetic latitude appears to be sufficient to place ATS-6, at times, into regions of space devoid of energetic electrons. Substorms, for example, as illustrated in Fig 7, have a greater effect on the energetic particle population off the magnetic equator. We can postulate that, during the later stages of a substorm, the geomagnetic field relaxes to more dipole-like configuration and the boundary of energetic particle trapping moves inward and equatorward past the ATS-6 spacecraft.

The comparisons of with ATS-1 ATS-6, data while still preliminary, indicate a surprisingly steep gradient in the energetic electron population as one moves away from the equator, in other words, a disk-like region of trapping of energetic electrons near $6.6 R_e$.

B The Solar Proton Event of July 4, 5, 6, 1974

Several solar proton events have been observed by the ATS-6 detectors during the first year of operation. Although the present time is a relatively quiescent part of the cycle of solar activity, modest outburst of protons (and heavy nuclei) were emitted by the sun during July and September 1974 and detected by this experiment and other experiments aboard ATS-6.

Solar protons of even relatively low energy are able to reach the synchronous altitude quite readily, without very much decrease in the flux as these particles transverse the outer regions of the geomagnetic field. This surprising result was first noted by experiments on ATS-1 [2], [4]. The ATS-6 experiments will provide very much better insight regarding the trajectories by which solar particles penetrate deeply into the magnetosphere, the gradients of solar particle fluxes near the synchronous orbits, and the effects of electromagnetic waves on the motion and lifetime of solar particles inside the geomagnetic cavity.

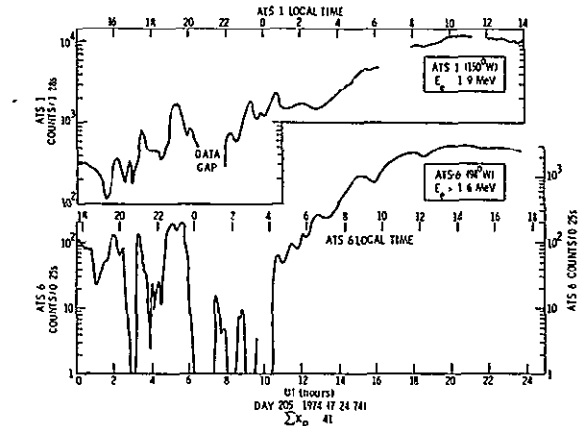

Fig 8 Comparison of energetic electron count rates observed by ATS-6 and ATS-1 during a magnetically disturbed day (day 205).

An overall view of July 1974 solar proton event, as observed by the experiment on ATS-6, is presented in Fig 9. The entire event is quite complex. The complexity arises partly because several emissions of particles by the Sun, somewhat separated in time, are superimposed and partly because disturbances in the geomagnetic field were also affecting the fluxes of solar particles.

The effect of one such disturbance, a compression of the geomagnetic field (presumably by an interplanetary shock) on solar protons moving within the geomagnetic field, is shown in Fig 10. The effect of such a compression is to increase the observed flux within a given energy channel because particles are accelerated. The acceleration process is identical to that which operates in betatrons. Furthermore, the changes in the configuration of the geomagnetic field cause the particle flux gradient to move past the detector. Study of the time development of flux changes, such as shown in Fig 10, can give information regarding the way particles interact with the spectrum at electromagnetic waves created during geomagnetic activity [3].

V Summary

After more than a year of operation in orbit, the experiment continues to provide excellent data. All design goals of the experiment have been met. While data analysis is still in the preliminary stages, it is clear that the experiment on ATS-6 will provide new and unique data regarding the behavior of energetic electrons at the synchronous altitude. In particular, correlation of ATS-6 data with data from other synchronous orbit spacecraft now operating (ATS-1, ATS-5) or planned for the future launches will give a much more complete view of the magnetospheric processes operating at high altitudes.

Acknowledgment

This experiment was the product of a large number of people whose efforts spanned many years, not because the

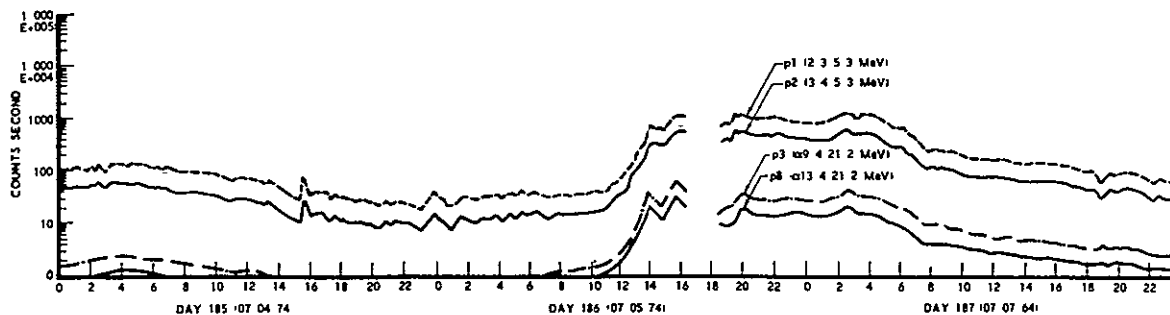

Fig 9 Count rates of proton and alpha channels during the solar proton event of July 1974 Data for two proton channels and two alpha channels for 4, 5, and 6 July 1974 are presented here

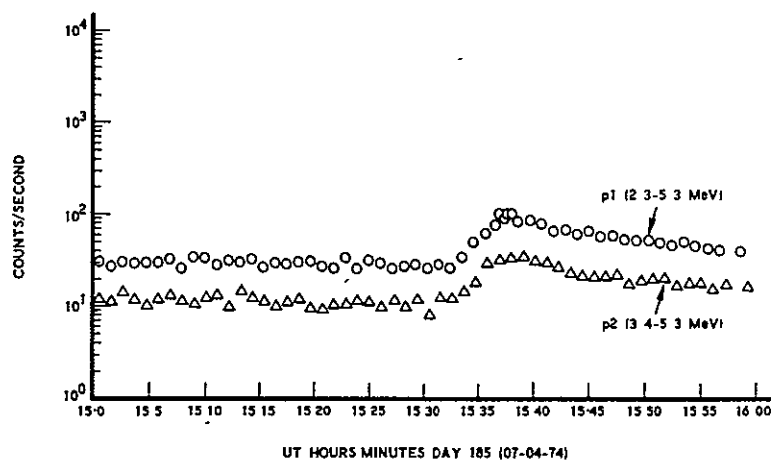

Fig 10 Increase in solar proton flux associated with a sudden commencement (a compression of the geomagnetic field) near 15 35 on July 4, 1974

experiment was particularly complex but because the launch of ATS-6 receded several times We are particularly grateful to Mrs G Roberts for the mechanical design of the experiment, to the Westinghouse group, particularly F McNally, J Ramsey, and W King, for their excellent support in the many test and checkout activities, and to R Wales of NASA Goddard Space Flight Center (GSFC) and his associates who saw the experiment through from beginning to end P McKowan of GSFC is providing excellent support in the data acquisition phase of this work Mrs. T Becker wrote the data analysis program which we have used to date

References

- [1] L A Frank, "Relationships of the plasma sheet, ring current, trapping boundary and plasmopause near the magnetic equator and local midnight," *J Geophys. Res*, vol 76, p 2265, 1971
- [2] L. Lanzerotti, "Penetration of solar protons and alphas to the geomagnetic equator," *Phys. Rev. Lett*, vol 21, p 929, 1968

- [3] G A Paulikas and J B Blake, "Effects of sudden commencements on solar protons at the synchronous altitude," *J Geophys Res*, vol 75, p 734, 1970
- [4] —, "Penetration of solar protons to synchronous altitude," *J Geophys Res*, vol 74, p 2161, 1969
- [5] —, "The particle environment at the synchronous altitude, models of the trapped radiation environment, vol 7: Long term variations," NASA, Washington, D C, SP-3024, 1971
- [6] G A Paulikas, J B Blake, S C Freden, and S S Imamoto, "Observations of energetic electrons at synchronous altitude, I General features and diurnal variations," *J Geophys. Res*, vol 73, p 4915, 1968
- [7] G A Paulikas, J B Blake, and J A Palmer, "Energetic electrons at the synchronous altitude A compilation of data," Aerospace Corp, El Segundo, Calif, Rept TR-0066 (5260-20)-4, November 1969
- [8] G W Singley and J I Vette, "A model environment for outer zone electrons," NSSDC 72-13, December 1972
- [9] J I Vette and A B Lucero, "Models of the trapped radiation environment, vol 3 Electrons at synchronous altitudes," NASA, Washington, D C, SP-3024, 1967



George A. Paulikas received the B.S. degree in engineering physics and the M.S. degree in physics from the University of Illinois, Urbana, in 1957 and 1958, respectively, and the Ph.D. degree in physics from the University of California, Berkeley, in 1961.

While at the University of California he was associated with the Lawrence Radiation Laboratory, doing research in plasma physics and atomic physics. In 1961 he joined the Space Physics Laboratory, The Aerospace Corporation, El Segundo, Calif., as a Member of the Technical Staff. In this capacity he conducted experimental space physics research, specializing in studies of trapped and quasitrapped radiation. He is now the Director of the Space Physics Laboratory. His fields of specialization include studies of the trapped radiation in the inner Van Allen Belt, measurements of the access of solar particles to the polar caps and to the synchronous orbit, construction of models of trapped radiation, and measurement of trapped alpha particles.

Dr. Paulikas is a member of the American Geophysical Union, the American Astronomical Society, the American Institute of Aeronautics and Astronautics, and Sigma Xi and is a Fellow of the American Physical Society. During 1957-1958 he was awarded a University of Illinois Fellowship, and from 1958-1961 he held a National Science Foundation Fellowship.



J. Bernard Blake received the B.S. degree in engineering physics in 1957, the M.S. degree in physics in 1958, and the Ph.D. degree in physics in 1962 from the University of Illinois, Urbana.

He was a Research Associate at the University of Illinois during 1962 when he joined the Space Physics Laboratory, The Aerospace Corporation, El Segundo, Calif., as a Member of the Technical Staff. He is presently Head of the Space Particles and Fields Department. His professional activity has included work in nuclear beta decay and parity nonconservation, the Mossbauer effect, studies of the geomagnetically trapped particles and auroral phenomena, cosmic ray sources, propagation and entry into the magnetosphere, and nuclear astrophysics. In applied work he has been concerned with nuclear weapons effects on ground and space systems, test monitoring, the interaction of the natural space environment with satellite systems, radiation damage effects, and the analysis of various satellite subsystems.

Dr. Blake is a member of the American Astronomical Society, the American Geophysical Union, the American Association for the Advancement of Science, Sigma Xi, and the American Physical Society. While he was at the University of Illinois he held industrial fellowships from Raytheon and Texas Instruments.



Sam S. Imamoto received an Engineering Associate of Arts degree from El Camino College El Camino College, Calif., in 1964.

He joined the Space Physics Laboratory, The Aerospace Corporation, El Segundo, Calif., in 1962. He is presently a Research Associate in the Space Particles and Fields Department. He has contributed to the design of space instrumentation orbited on more than 20 spacecraft. He was responsible for the design of the Aerospace Corp. experiment on ATS-1 as well as for the design of the Aerospace Corp. experiment on ATS-6. His responsibilities have included all phases of engineering effort from inception to spacecraft integration.

II. OPERATIONAL, INSTRUMENTAL AND DATA ANOMALIES

The various anomalies observed during the 1974-1977 interval in our data are described below. The anomalies have been grouped into several categories and have each been given a distinctive (if sometimes irreverent) name.

A. Instrumental Anomalies

This category describes malfunctions which are directly traceable to our experiment.

1. The E2 Anomaly

We found, early in the operations of ATS-6, that the E2 channel totally ceased counting for a few hours at a time on a given day. This anomaly was found to be associated with the temperature of our instrument: when our instrument was very cold, apparently an intermittent open-circuit can develop in the E2 data stream. This anomaly was observed only early after experiment turn-on (< 170, 1974). The practical consequence is that there are some zero hourly averages for E2 during mid-1974, which have been detected.

2. The E4 Anomaly

The E4 channel exhibited noisy behavior for some local times between Day 140, 1975 and Day 130, 1976. We suspect that the temperature of the E4 detector was sufficiently high so that the detector became noisy. Because of the UNH anomaly (see Section B1, below), we were not able to determine the temperature at which this (the E4) anomaly occurred. The practical consequences of the E4 anomaly is that we have ignored all E4 data between 140, 1975 and 130, 1976 in our work and have deleted these data from our input to NSSDC.

B. Operational Anomalies

The class of anomalies includes all malfunctions which affected our data, but whose sources were elsewhere in the ATS-6 spacecraft.

1. The UNH Anomaly

Turn-on of the University of New Hampshire (UNH) experiment on Day 169, 1974 caused a malfunction in the EME encoder. Specifically, word 189, which contained the health data from our experiment, was affected so that no valid measurements of the temperatures in our experiment were obtained after that date. The encoder apparently partially recovered around Day 139, 1977, however, the decision to operate the UNH experiment starting on Day 171, 1977, again destroyed Word 189. The practical consequences are that no temperature data from our experiment are available to aid in the analysis of other anomalies we have observed.

2. The HAC Anomaly

The operation of the Hughes Aircraft Company solar cell experiment on the ATS-6 EME caused a peculiar (and not understood) interaction, with the spacecraft data encoder which had the effect of dropping a "one" in the most significant bit of the E1 channel (only) at high counting rates. This occurred between 0030 and 0330 UT (during the early ATS-6 operation period) and was apparently associated with a mode change ("lockout") of the HAC experiment. Although only the E1 channel was affected, this anomaly apparently introduced a sufficient number of warning flags into the data tapes we received from Goddard, that our data processing program did not process the first three (UT) hours of data for days shortly after experiment turn-on. As a result, the first three (UT) hourly averages may be missing from the data for some fraction of 1974.

C. Data Anomalies

The anomalies described below are associated with malfunctions in the data processing systems on the ground as well as with introduction of noise into the data stream by telemetry noise or link dropouts.

1. Proton Data

The proton channels of our experiments, as expected, registered only very low countrates except during solar proton events (rare in 1974-1977) and except during some classes of magnetospheric disturbances (also relatively rare). Consequently, noisy data, if uncorrected, has a very

significant effect on long-term averages of the countrates. There has not been any systematic effort to remove noisy data points from the proton data, although we have edited out suspect hourly averages. Users of the proton data are hereby cautioned: proceed carefully, the counts you see may be but noise.

2. Mis-Labeled Data

Despite the best efforts of all concerned, tapes are occasionally mislabeled, not labeled in a consistent manner (date/day number), etc. We have tried to eliminate all such "malfunctions" using such tests as we considered appropriate, but there may well be some pathological cases (i. e., mis-identified days of data) that we did not detect. Users are encouraged to communicate their suspicions to us so that we may improve the data set.

3. Missing Days of Data, Partial Days

The data quality from ATS-6, although truly outstanding, was nevertheless not perfect. The users will find that the present data set contains some partial days of data and some days are entirely missing. The missing days are typically those which have defied processing for various reasons. After several attempts, we have simply called a halt and have asked NASA for replacement tapes. When these tapes arrive, they will be processed and the gaps will be filled. The problem should be put into perspective: at the time of writing (August 1977), for example, only 5 days of 1974 data have resisted processing and 4 days of 1975 data have not been processed. No doubt some interesting geophysical event will have occurred on one of those missing days, following the well-known perversity of nature.

4. Magnetometer Data

The magnetometer data incorporated into our data set was graciously provided by Dr. R. L. McPherron of UCLA. The field information was derived from the telemetry data as described in Section III.

Magnetometer data may not be associated with all days of our data because we have processed some quick-look tapes which did not include the magnetometer data (or, for that matter, any ephemeris or aspect information). There was also a malfunction in the UCLA magnetometer which we did not detect in a timely fashion. As a result, some of the magnetometer data appears strange because our processing routine did not compensate for the malfunction (failure of one axis). Upon notification of the malfunction, we changed the magnetometer data displays from the V, D, H system to one which presented the data in coordinates of the magnetometer axes (plus to total field). We suggest that users interested in the magnetometer data go directly to the UCLA magnetometer data held by NSSDC, rather than attempting to use our version of the UCLA data.

III. DESCRIPTION
OF DATA

III. DESCRIPTION OF DATA REDUCTION AND DATA FORMATS

A. Aerospace Corporation Experimental Tapes

Each data tape received from GSFC contains one day of data, including data from the Aerospace Corporation Omnidirectional Spectrometer and the UCLA Magnetometer, housekeeping data, and ephemeris data. The tapes contain several files, each file headed by a 132 8-bit word (18 CDC 60-bit words) coded title record, followed by many 64 second frames of data, 32x64 9-bit T/M words and 22 36-bit coded ephemeris words (321 CDC 60-bit words).

B. Data Reduction and Processing

Each record of T/M data contains one frame, 64 seconds, of data. From the original T/M Aerospace receives 32 measurements/second, including the following:

<u>Word</u>	<u>Description</u>
27, 28, 29	UT in milliseconds
1, 25	Counter, 0-63
23	Flag, 0 if no error
12	(E1, E2, E3, E4) x 16
15	(P1, P2, P3, P4, P5, P6, P7, P8) x 8
22	Temps, at seconds 53, 54, 55, 56
3, 4, 5	B _x , B _y , B _z , fine
6, 7, 8	B _x , B _y , B _z , medium

The data is checked to insure that the counters (words 1 and 25) are correct, the flag (word 23) is correct, and that the time (words 27, 28, 29) are increasing. If all this checks are passed that data is processed, otherwise not.

The processing includes conversion of the T/M data to fluxes for the omnidirectional spectrometer, gammas for the magnetometer, and degrees for the thermistors. In addition to the second by second values, frame averages, 5 minute averages, and one hour averages are calculated. These are used in detailed plots, and for our two data tape formats, the Detailed Data Tape Format and Master Data Tape Format described in section C.

1. The Ephemeris Data

The ephemeris data consists of 47 values for each 64 second frame, in the ORB/ATT format, detailed in Appendix A. In particular the radius, latitude and longitude are obtained from words 18, 19 and 20.

For the calculation of local time the day and year are taken from the title record, and the time in milliseconds from word 2 of the ephemeris data. Then the position of the sun in ECI coordinates is calculated, and compared with the satellite position in ECI coordinates, words 3, 5, and 7, to calculate the local time.

The attitude transformation matrix, to transform a vector from local vertical to spacecraft body axes, is read from words 36 to 44.

Finally, the matrix to transform from local vertical to dipole coordinates is calculated. This coordinate system has the z-axis parallel to the earth's dipole axis (north positive) and the x-axis chosen so that the satellite is in the x-z plane.

2. The Particle Measurements

The particle measurements are transmitted in the T/M as 9-bit floating point numbers. These T/M values are converted to counts, and then to fluxes, using the values below. Four electron measurements are made each second, and eight "proton" measurements are made each second. The energies and geometric factors for the 12 measurements are listed below. (Note that the electron multiplication factors differ from that given in Section I because they include a factor of 4 to convert from counts/.25 sec to counts/sec).

<u>Channel</u>	<u>Particle</u>	<u>Passband/ Threshold (MeV)</u>		<u>Factor</u>
E1	e	.140-.600	34.783	cm ² /sec-sr
E2	e	> .700	1146.1	cm ² /sec
E3	e	> 1.55	227.27	cm ² /sec
E4	e	> 3.90	58.140	cm ² /sec
P1	P	2.3-5.3	6.2500	cm ² /sec-sr
P2	P	3.4-5.3	6.2500	cm ² /sec-sr
P3	α	9.4-21.2	6.2500	cm ² /sec-sr
P4	P	12-26	222.22	cm ² /sec
P5	α	46-100	208.33	cm ² /sec
P6	P	20-52	53.193	cm ² /sec
P7	P	40-90	24.272	cm ² /sec
P8	α	13.4-21.2	6.2500	cm ² /sec-sr

3. The Magnetometer Measurements

The UCLA Magnetometer gives medium and fine readings for three axes once/second, or 64 samples/frame. The T/M values are converted to gammas in spacecraft coordinates. Then if the local vertical-spacecraft body axis transformation is available, the three components are rotated to local vertical, and then to "dipole" coordinates. If the local vertical-spacecraft body axis is not available, the magnitude of the field is calculated, and the three components set to -1.

The calibration coefficients used were obtained using a least-squares fit to processed magnetometer data supplied by R. McPherron. The toggling of the fine and medium readings was handled improperly, so an error as much as 16 gamma may occur on any reading, but the 5 minute and 1 hour averages should be unaffected.

C. The Data Tape Formats

1. The Detailed Data Tape

The Detailed Data Tape Format is shown in Appendix B. It contains the processed data on a frame by frame basis, followed by

5 minute and 1 hour averages. Generally there are 10 days of data per tape.

The electron and proton measurements are decommutated each frame, in order to keep the times correct. Only every fourth magnetometer measurement is copied. Time is monotonic increasing, and data is filled with -1's in cases of overlap.

After the frame data, there is one record of 0's to indicate the beginning of the 5 minute and 1 hour averages.

2. The Master Data Tape

The Master Data Tape Format is shown in Appendix C. It contains the hourly averages from the electron, proton and magnetometer data, one day per record. All the days for which there is data are in order chronologically on one tape. It is anticipated that this will be the more useful data for continuing studies.

These data have been examined in detail and all suspect data for the electron and proton measurements have been set to -1.

APPENDIX A

ORIGINAL PAGE 1
OF POOR QUALITY

ATS--F EPHEMERIS DATA
ORB/ATT TAPE FORMAT

WORD

1	① DAY COUNT	② MILLISECONDS OF DAY	
2	③ x COORDINATE		④ x COORDINATE
3	⑤ y COORDINATE		⑥ y COORDINATE
4	⑦ z COORDINATE		⑧ z COORDINATE
5	⑨ YAW		⑩ YAW RATE
6	⑪ ROLL		⑫ ROLL RATE
7	⑬ PITCH		⑭ PITCH RATE
8	⑮ Z_B - AXIS INTERCEPT LATITUDE		⑯ Z_B - AXIS INTERCEPT LONGITUDE
9	⑰ ROTATION OF BODY Y_B -AXIS FROM NORTH		⑱ HEIGHT ABOVE EARTH (SUBSATELLITE POINT)
10	⑲ SUBSATELLITE LATITUDE		⑳ SUBSATELLITE LONGITUDE
11	㉑ RANGE FROM SPACECRAFT TO Z_B - AXIS INTERCEPT		㉒ CROSS POLARIZATION ANGLE
12	㉓ Θ (Theta)		㉔ Φ (Phi)
13	㉕ ^{NF} x-COORDINATE	㉖ ^{NF} y-COORDINATE	㉗ ^{NF} z-COORDINATE
14	㉘ ^{EF} x-COORDINATE	㉙ ^{EF} y-COORDINATE	㉚ ^{EF} z-COORDINATE
15	㉛ YAW UNCERTAINTY	㉜ ROLL UNCERTAINTY	㉝ PITCH UNCERTAINTY
16	㉞ α (Alpha)	㉟ ATTITUDE SENSOR I.D.	
17	㊱ a_{11}		㊲ a_{12}
18	㊳ a_{13}		㊴ a_{21}
19	㊵ a_{22}		㊶ a_{23}
20	㊷ a_{31}		㊸ a_{32}
21	㊹ a_{33}		㊺ PROGRAM STATUS
22	㊻ CALIBRATION I.D.		㊼ MISALIGNMENT I.D.

OUTPUT PARAMETER NO. 1

Name - Day Count of Year

Analytic Definition - This identifies the day on which the processed telemetry frame was transmitted by the spacecraft. The starting point for the count is 0000 hours of the first day of the calendar year (1 January).

Units - Days

Format - This is a nine-bit binary word with the most significant bit (MSB) leading. No sign bit exists.

OUTPUT PARAMETER NO. 2

Name - Milliseconds of Day

Analytic Definition - This identifies the time of day on which the processed telemetry frame was transmitted by the spacecraft. The starting point for this parameter is 0000 hours of the day specified in Output Parameter No. 1 (Day Count of Year).

Units - Milliseconds (Seconds x 10^{+3})

Format - This is a 27-bit binary word with the MSB leading. No sign bit exists.

OUTPUT PARAMETER NO. 3

Name - X-Coordinate

Analytic Definition - The X-component of the position vector of the ATS-F spacecraft expressed in an earth centered inertial (ECI) coordinate system defined below.

X-axis points to the first point of Aries true-of-date and lies in the equatorial plane of the earth

Z-axis points along the Polaris spin axis of the earth; the positive direction is north

Y-axis is chosen to complete a right-handed orthogonal set

Units - Tenths of kilometers (kilometers x 10^{+1})

Format - This is a 20-bit binary word. The first bit is used for the sign and the following nineteen bits for magnitude with the MSB leading.

OUTPUT PARAMETER NO. 4

Name - \dot{X} -Coordinate

Analytic Definition - The X-component of the velocity vector of the ATS-F spacecraft expressed in the ECI coordinate system described in the Analytic Definition of Output Parameter No. 3

Units - Meters per second

Format - This is a 16-bit binary word. The first bit is used for the sign and the following 15 bits for magnitude with the MSB leading.

OUTPUT PARAMETER NO. 5

Name - Y-Coordinate

Analytic Definition - The Y-component of the position vector of the ATS-F spacecraft expressed in the ECI coordinate system described in the Analytic Definition of Output Parameter No. 3

Units - Tenths of kilometers (kilometers $\times 10^{+1}$)

Format - This is a 20-bit binary word. The first bit is used for the sign and the following 19 bits for magnitude with the MSB leading.

OUTPUT PARAMETER NO. 6

Name - \dot{Y} -Coordinate

Analytic Definition - The Y-component of the velocity vector of the ATS-F spacecraft expressed in the ECI coordinate system defined in the Analytic Definition of Output Parameter No. 3

Units - Meters per second

Format - This is a 16-bit binary word. The first bit is used for the sign and the following 15 bits for magnitude with the MSB leading.

OUTPUT PARAMETER NO. 7

Name - Z-Coordinate

Analytic Definition - The Z-component of the position vector of the ATS-F spacecraft expressed in the ECI coordinate system described in the Analytic Definition of Output Parameter No. 3

Units - Tenths of kilometers (kilometers $\times 10^{+1}$)

Format - This is a 20-bit binary word. The first bit is used for the sign and the following 19 bits for magnitude with the MSB leading.

OUTPUT PARAMETER NO. 8

Name - $\dot{\bar{Z}}$ -Coordinate

Analytic Definition - The \bar{Z} -component of the velocity vector of the ATS-F spacecraft expressed in the ECI coordinate system defined in the Analytic Definition of Output Parameter No. 3

Units - Meters per second

Format - This is a 16-bit binary word. The first bit is used for the sign and the following 15 bits for magnitude with MSB leading.

OUTPUT PARAMETER NO. 9

Name - Yaw

Analytic Definition - The first of three rotations about ATS-F body axes that are used to define ATS-F attitude relative to the Local Vertical (LV) coordinate system defined below.

Z_C points along the local vertical toward the center of mass of the earth

X_C points east parallel to the earth's equatorial plane

Y_C is chosen to complete a right-handed orthogonal set (nominally points south)

The Euler rotations, in the sequence of their application, are as follows:

Yaw - rotation about the spacecraft body Z-axis (Z_B)

Roll - rotation about the spacecraft body X-axis (X_B)

Pitch - rotation about the spacecraft body Y-axis (Y_B)

Units - Thousandths of a degree (degrees $\times 10^{+3}$). Yaw is always taken to be positive ranging from 0 to 360 degrees.

Format - This is a 20-bit binary word with MSB leading. No sign bit exists.

OUTPUT PARAMETER NO. 10

Name - Yaw Rate

Analytic Definition - The time rate of change of the yaw Euler angle defined in the Analytic Definition of Output Parameter No. 9

Units - Thousandths of a degree per minute (degrees per minute x 10^{+3})

Format - This is a 16-bit binary word. The first bit is used for the sign and the following 15 bits for magnitude with MSB leading.

OUTPUT PARAMETER NO. 11

Name - Roll

Analytic Definition - The second rotation in the Euler sequence used to define ATS-F attitude. This rotation is about the spacecraft body X-axis (X_p). The attitude is relative to the LV coordinate system defined in the Analytic Definition of Output Parameter No. 9

Units - Thousandths of a degree (degrees x 10^{+3})

Format - This is a 20-bit binary word. The first bit is used for the sign and the following 19 bits for magnitude with MSB leading.

OUTPUT PARAMETER NO. 12

Name - Roll Rate

Analytic Definition - The time rate of change of the roll Euler angle defined in the Analytic Definition of Output Parameter No. 11

Units - Thousandths of a degree per minute (degrees per minute x 10^{+3}).

Format - This is a 16-bit binary word. The first bit is used for the sign and the following 15 bits for magnitude with the MSB leading.

OUTPUT PARAMETER NO. 13

Name - Pitch

Analytic Description - The third rotation in the Euler sequence used to define ATS-F attitude. This rotation is about the spacecraft body Y-axis. The attitude is relative to the LV coordinate system defined in the Analytic Definition of Output Parameter No. 9

Units - Thousandths of a degree (degrees x 10^{+3}).

Format - This is a 20-bit binary word. The first bit is used for the sign and the following 19 bits for magnitude with the MSB leading.

OUTPUT PARAMETER NO. 14

Name - Pitch Rate

Analytic Definition - The time rate of change of the pitch Euler angle defined in the Analytic Definition of Output Parameter No. 13

Units - Thousandths of a degree per minute (degrees per minute $\times 10^{+3}$).

Format - This is a 16-bit binary word. The first bit is used for the sign and the following 15 bits for magnitude with the MSB leading.

OUTPUT PARAMETER NO. 15

Name - Z_B -Axis Intercept Latitude

Analytic Definition - The latitude of the intercept point of a line coincident with the spacecraft body Z-axis (Z_B) and the surface of the earth. An ellipsoidal model of the earth is used.

Units - Hundredths of a degree (degrees $\times 10^{+2}$).

Format - This is an 18-bit binary word. The first bit is used for the sign and the following 17 bits for magnitude with MSB leading.

OUTPUT PARAMETER NO. 16

Name - Z_B -Axis Intercept Longitude

Analytic Description - The longitude of the intercept point of a line coincident with the spacecraft body Z-axis (Z_B) and the surface of the earth. An ellipsoidal model of the earth is used.

Units - Hundredths of a degree (degrees $\times 10^{+2}$). Longitude is always positive measured East from Greenwich and lies in the range 0 to 360 degrees.

Format - This is an 18-bit binary word with the MSB leading. No sign bit exists.

OUTPUT PARAMETER NO. 17

Name - Rotation of Y_B -Axis from North

Analytic Definition - The angle between the following planes.

Plane 1: Plane formed by the spacecraft Z-axis (Z_B) and the local north vector (i.e., $-Y_C$, see Analytic Definition of Output Parameter No. 9).

Plane 2: Plane formed by the spacecraft Z-axis (Z_B) and Y-axis (Y_B).

Units - Hundredths of a degree (degrees $\times 10^{+2}$).

Format - This is an 18-bit binary word with MSB leading. No sign bit exists.

OUTPUT PARAMETER NO. 18

Name - Height Above Subsatellite Point

Analytic Definition - The height of the ATS-F spacecraft above the surface of the earth measured along the line between the spacecraft and the center of mass of the earth. An ellipsoidal model of the earth is used.

Units - Kilometers

Format - This is an 18-bit binary word. No sign bit exists.

OUTPUT PARAMETER NO. 19

Name - Subsatellite Latitude

Analytic Definition - The geodetic latitude of the intercept point on the surface of the earth of a line between the spacecraft and the center of mass of the earth. An ellipsoidal model of the earth is used.

Units - Hundredths of a degree (degrees $\times 10^{+2}$).

Format - This is an 18-bit binary word. The first bit is used for the sign and the following 17 bits for magnitude with the MSB leading.

OUTPUT PARAMETER NO. 20

Name - Subsatellite Longitude

Analytic Definition - The longitude of the intercept point on the surface of the earth of a line between the spacecraft and the center of mass of the earth. An ellipsoidal model of the earth is used.

Units - Hundredths of a degree (degrees $\times 10^{+2}$). Longitude is always positive measured east from Greenwich and lies between 0 and 360 degrees.

Format - This is an 18-bit binary word with the MSB leading. No sign bit exists.

OUTPUT PARAMETER NO. 21

Name - Range from Spacecraft to Z_B -Axis Intercept

Analytic Description - The distance between the spacecraft and the point defined by the intersection of the Z-axis (Z_B) with the earth's surface given in the Analytic Descriptions of Output Parameters Nos. 15 and 16.

Units - Tenths of a kilometer (kilometers $\times 10^{+1}$).

Format - This is a 20-bit binary word with MSB leading. No sign bit exists.

OUTPUT PARAMETER NO. 22

Name - Cross-Polarization Angle

Analytic Description - The angle between the ATS-F receiver and a vertically polarized antenna located at the Z-axis (Z_B) intercept point. It is the acute angle between the following two planes:

Plane 1: Defined by (a) center of mass of the earth and (b) the spacecraft body Z-axis (Z_B)

Plane 2: Defined by (a) the location of an antenna element in the spacecraft body X-Y plane (X_B - Y_B), and (b) the spacecraft body Z-axis (Z_B).

Units - Hundredths of a degree (degrees $\times 10^{+2}$), in the range 0 to 360 degrees.

Format - This is a 16-bit binary word with the MSB leading. No sign bit exists.

OUTPUT PARAMETER NO. 23

Name - Antenna Pattern Angle θ

Analytic Description - The angle between the spacecraft Z-axis (Z_B) and the vector to a preselected ground station. The ground station coordinates will be user specified and available upon request.

Units - Hundredths of a degree (degrees $\times 10^{+2}$).

Format - This is an 18-bit binary word with the MSB leading. No sign bit exists.

OUTPUT PARAMETER NO. 24

Name - Antenna Pattern Angle \emptyset

Analytic Description - The angle between the following two planes.

Plane 1: Plane defined by the spacecraft body X and Z axes (X_B, Z_B)

Plane 2: Plane defined by the vector to a preselected ground station and the spacecraft body Z-axis (Z_B)

The ground station coordinates will be user specified and available upon request.

Format - This is an 18-bit binary word with the MSB leading. No sign bit exists.

OUTPUT PARAMETER NO. 25

Name - NFX

Analytic Description - The X-component (i_{NF} direction) of the unit vector to the sun expressed in the Quartz experiment's coordinate system for the sensor assembly on the north face of the Earth Viewing Module (EVM).

Units - Thousandths of a unit (unit $\times 10^{+3}$).

Format - This is a 12-bit binary word. The first bit is used for the sign and the following 11 bits for magnitude with the MSB leading.

OUTPUT PARAMETER NO. 26

Name - NFY

Analytic Description - The Y-component (j_{NF} direction) of the unit vector to the sun expressed in the Quartz experiment's coordinate system for the sensor assembly on the north face of the EVM.

Units - Thousandths of a unit (unit $\times 10^{+3}$).

Format - This is a 12-bit binary word. The first bit is used for the sign and the following 11 bits for magnitude with the MSB leading.

OUTPUT PARAMETER NO. 27

Name - NFZ

Analytic Description - The Z-component (k_{NF} direction) of the unit vector to the sun expressed in the Quartz experiment's coordinate system for the sensor assembly on the north face of the EVM.

Units - Thousandths of a unit (unit $\times 10^{+3}$).

Format - This is a 12-bit binary word. The first bit is used for the sign and the following 11 bits for magnitude with the MSB leading.

OUTPUT PARAMETER NO. 28

Name - EFX

Analytic Description - The X-component (\underline{i} direction) of the unit vector to the sun expressed in the ATF Experiment's coordinate system for the sensor assembly on the east face of the EVM.

Units - Thousandths of a unit (unit x 10^{+3}).

Format - This is a 12-bit binary word. The first bit is used for the sign and the following 11 bits for magnitude with the MSB leading.

OUTPUT PARAMETER NO. 29

Name - EFY

Analytic Description - The Y-component (\underline{j} direction) of the unit vector to the sun expressed in the ATF Experiment's coordinate system for the sensor assembly on the east face of the EVM.

Units - Thousandths of a unit (unit x 10^{+3}).

Format - This is a 12-bit binary word. The first bit is used for the sign and the following 11 bits for magnitude with the MSB leading.

OUTPUT PARAMETER NO. 30

Name - EFZ

Analytic Description - The Z-component (\underline{k} direction) of the unit vector to the sun expressed in the ATF Experiment's coordinate system for the sensor assembly on the east face of the EVM.

Units - Thousandths of a unit (unit x 10^{+3}).

Format - This is a 12-bit binary word. The first bit is used for the sign and the following bits for magnitude with the MSB leading.

OUTPUT PARAMETER NO. 31

Name - Yaw Uncertainty

Analytic Description - The statistical uncertainty in the estimate of the yaw angle. It is the square root of the diagonal element of the state covariance matrix corresponding to the yaw state.

Units - Thousandths of a degree (degrees x 10^{+3}).

Format - This is a 12-bit binary word with the MSB leading. No sign bit exists.

OUTPUT PARAMETER NO. 32

Name - Roll Uncertainty

Analytic Description - The statistical uncertainty in the estimate of the roll angle. It is the square root of the diagonal element of the state covariance matrix corresponding to the roll state.

Units - Thousandths of a degree (degrees x 10^{+3}).

Format - This is a 12-bit binary word with the MSB leading. No sign bit exists.

OUTPUT PARAMETER NO. 33

Name - Pitch Uncertainty

Analytic Description - The statistical uncertainty in the estimate of the pitch angle. It is the square root of the diagonal element of the state covariance matrix corresponding to the pitch state.

Units - Thousandths of a degree (degrees x 10^{+3}).

Format - This is a 12-bit binary word with the MSB leading. No sign bit exists.

OUTPUT PARAMETER NO. 34

Name - Offset Pointing Angle, α

Analytic Description - The angle between the line of sight to the subsatellite point (output parameters 19 and 20) and the spacecraft Z-axis (Z_B).

Units - Hundredths of a degree (degrees x 10^{+2}).

Format - This is a 14-bit binary word with the MSB leading. No sign bit exists.

OUTPUT PARAMETER NO. 35

Name - Attitude Sensor ID

Analytic Description - This identifies the attitude sensors whose data is being utilized in the attitude estimation process.

Units - None (binary flags)

Format - This is a string of 22 bits. Each bit corresponds to a specific sensor on ATS-F and indicates whether that sensor's output is used in the attitude estimation process. The state "1" indicates it is used. The bits refer to the following sensors in the indicated order.

<u>Bit No.</u>	<u>Sensor</u>
1	Earth Sensor
2	Polaris Sensor No. 1
3	Polaris Sensor No. 2
4	Digital Sun Sensor No. 1
5	Digital Sun Sensor No. 2
6	Digital Sun Sensor No. 3
7	Digital Sun Sensor No. 4
8	Digital Sun Sensor No. 5
9	Interferometer No. 1
10	Interferometer No. 2
11	Monopulse VHF
12	Monopulse S-Band
13	Monopulse C-Band
14	Coarse Sun Sensor No. 1
15	Coarse Sun Sensor No. 2
16	Coarse Sun Sensor No. 3
17	Coarse Sun Sensor No. 4
18	Fine Sun Sensor No. 1
19	Fine Sun Sensor No. 2
20	Rate Gyro Assembly No. 1
21	Rate Gyro Assembly No. 2
22	Spare

OUTPUT PARAMETERS NOS. 36 THROUGH 44

Name - Elements of the Attitude Transformation Matrix (a_{ij})

Analytic Description - Elements of the transformation matrix from the local vertical (L-V) coordinate frame to the spacecraft body coordinate frame. The matrix is of the form:

$$[A] = \begin{vmatrix} a_{11} & a_{12} & a_{13} \\ a_{21} & a_{22} & a_{23} \\ a_{31} & a_{32} & a_{33} \end{vmatrix}$$

The matrix transforms a vector in the local vertical coordinate frame (\bar{V}_{L-V}) to a vector in the spacecraft body frame (\bar{V}_B) according to the following relationship:

$$\bar{V}_B = [A] \bar{V}_{L-V}$$

Units - Hundred thousandths of a unit (unit x 10^{+5})

Format - Each element is an 18-bit binary word. The first bit is used for the sign and the following 17 bits for magnitude with the MSB leading.

<u>Output Parameter No.</u>	<u>a_{ij}</u>
36	a_{11}
37	a_{12}
38	a_{13}
39	a_{21}
40	a_{22}
41	a_{23}
42	a_{31}
43	a_{32}
44	a_{33}

OUTPUT PARAMETER NO. 45

Name - Program Status

Analytic Description - Code words for internal use by attitude generation personnel to identify program modifications

Units - None. Code words.

Format - To be determined.

OUTPUT PARAMETER NO. 46

Name - Calibration Identifier

Analytic Description - Code words for internal use by attitude generation personnel to identify telemetry calibration curves used in generating attitude

Units - None. Code words.

Format - To be determined

OUTPUT PARAMETER NO. 47

Name - Misalignment Identifier

Analytic Description - Code words for internal use by attitude generation personnel to identify attitude sensor misalignment sets used in generating attitudes

Units - None. Code words.

Format - To be determined

APPENDIX B.

DETAILED DATA TAPE FORMAT

Each day is one file of many 288 CDC 60-bit records.

Record 1:

<u>Word</u>	<u>Type</u>	<u>Description</u>
1- 18	Bits	The original title record (132 8-bit characters) plus 24 "0" bits.
19	Hollerith	Date of data
20	"	Date Processed by Aerospace Corporation
21	"	Tape Number Assigned by Aerospace Corporation
22-288		Fill, "0"s.

Records 2 - Number of Frames, N, +1.

<u>Word</u>	<u>Type</u>	<u>Description</u>
1	Integer	Day of Year
2	"	Year
3	Real	UT, seconds, of ephemeris, or -1.
4	"	Radius, ER, or -1.
5	"	Latitude, Deg., or -1.
6	"	Longitude, Deg., or -1.
7	"	Local Time, Hrs., or -1.
8	"	0.
9- 72	"	UT, seconds, or -1.
73-136	"	(E1, E2, E3, E4) x 16, or -1.
137-200	"	(P1, P2, P3, P4, P5, P6, P7, P8) x 8, or -1.
201-216	"	B _x
217-232	"	B _y
233-248	"	B _z
249-264	"	B

} From Title Record

} From Frames 4, 64, 4, or -1.

<u>Word</u>	<u>Type</u>	<u>Description</u>
265-268	"	Temperatures
269-288	"	Fill, 0

Records N + 2 to N + 20, all words real.

<u>Record</u>	<u>Words</u>	<u>Description</u>
N+ 2	1-288	Fill, 0
N+ 3	"	E1, 288 5 minute averages, or -1.
N+ 4	"	E2, "
N+ 5	"	E3, "
N+ 6	"	E4, "
N+ 7	"	P1, "
N+ 8	"	P2, "
N+ 9	"	P3, "
N+10	"	P4, "
N+11	"	P5, "
N+12	"	P6, "
N+13	"	P7, "
N+14	"	P8, "
N+15	"	B _x "
N+16	"	B _y "
N+17	"	B _z "
N+18	"	B, "
N+19	1- 24	E1, 24 1 hour averages, or -1.
"	25- 48	E2, "
"	49- 72	E3, "
"	73- 96	E4, "
"	97-120	P1, "
"	121-144	P2, "
"	145-168	P3, "
"	169-192	P4, "
"	193-216	P5, "
"	217-240	P6, "
"	241-264	P7, "
"	265-288	P8, "

<u>Record</u>	<u>Words</u>		<u>Description</u>
N+20	1- 24	B _x	"
"	25- 48	B _y	"
"	49- 72	B _z	"
"	73- 95	B,	"
"	96-288	Fill, 0	

MASTER DATA TAPE FORMAT

Each day is a 496 CDC 60-bit word record.

<u>Word</u>	<u>Type</u>	<u>Description</u>
1	Hollerith	Tape Number Assigned by Aerospace Corporation
2	"	Date Processed by Aerospace Corporation
3	Integer	Day of Year
4	"	Month
5	"	Day of Month
6	"	Year
7	Real	Radius, ER, or -1.
8	"	Latitude, Deg., or -1.
9	"	Longitude, Deg., or -1.
10- 16	"	Fill, -1.
17- 40	"	E1, Hourly averages, or -1.
41- 64	"	E2 "
65- 88	"	E3 "
89-112	"	E4 "
113-136	"	P1 "
137-160	"	P2 "
161-184	"	P3 "
185-208	"	P4 "
209-232	"	P5 "
233-256	"	P6 "
257-280	"	P7 "
281-304	"	P8 "
305-328	"	B _x "
329-352	"	B _y "
353-376	"	B _z "
377-400	"	B "
401-496	"	Fill, -1.

} From Title Record

PRECEDING PAGE BLANK NOT RECORDED

IV. DATA CATALOG

REC	AC TAPE	PROC	DY	MN	DM	YEAR	F	LAT	LON	E1	P1	BX
1	044545	HO	17	2	3	1977	165	6	14	1974	0.00	-79.05
2	044462	HO	10	12	3	1977	166	6	15	1974	0.00	-79.72
3	044496	HO	06	23	1	1976	167	6	16	1974	0.00	-77.15
4	044511	HO	06	23	1	1976	168	6	17	1974	0.00	-78.25
5	045679	HO	07	15	1	1977	169	6	18	1974	0.00	-73.48
6	045688	HO	07	23	1	1977	170	6	19	1974	0.00	-740.96
7	044547	HO	07	16	2	1977	171	6	20	1974	0.00	-72.80
8	044485	HO	06	30	2	1976	172	6	21	1974	0.00	-75.72
9	044499	HO	06	31	3	1976	173	6	22	1974	0.00	-71.39
10	044498	HO	06	30	2	1976	174	6	23	1974	0.00	-70.02
11	044507	HO	05	30	2	1976	175	6	24	1974	0.00	-75.94
12	044494	HO	06	30	2	1976	176	6	25	1974	0.00	-65.88
13	044495	HO	06	30	2	1976	177	6	26	1974	1.10	-79.26
14	044546	HO	07	18	2	1977	178	6	27	1974	20.37	-87.88
15	044513	HO	07	30	2	1976	179	6	28	1974	20.37	-77.93
16	044516	HO	06	30	2	1976	180	6	29	1974	1.17	-75.55
17	044517	HO	07	01	3	1976	181	6	30	1974	0.00	-72.46
18	044500	HO	07	01	1	1976	182	6	31	1974	0.00	-67.66
19	044505	HO	07	09	7	1976	183	7	3	1974	0.00	-68.23
20	044515	HO	07	02	7	1976	184	7	3	1974	0.00	-69.66
21	044544	HO	07	13	7	1977	185	7	7	1974	0.00	-80.16
22	044501	HO	07	03	7	1976	186	7	7	1974	0.00	-82.32
23	045687	HO	05	23	7	1977	187	7	7	1974	0.00	-81.00
24	044492	HO	07	02	7	1976	188	7	7	1974	0.00	-94.76
25	044493	HO	07	02	7	1976	189	7	3	1974	0.00	-80.83
26	045686	HO	07	23	7	1977	190	7	9	1974	0.00	-79.53
27	045681	HO	07	15	7	1977	191	7	7	1974	0.00	-77.53
28	044484	HO	07	02	7	1976	192	7	10	1974	0.00	-77.17
29	044518	HO	07	03	7	1976	193	7	12	1974	0.00	-76.17
30	044512	HO	07	03	7	1976	194	7	13	1974	0.00	-83.35
31	044490	HO	07	03	7	1976	195	7	14	1974	0.00	-81.00
32	045682	HO	07	15	7	1977	196	7	15	1974	0.00	-75.11
33	044113	HO	07	09	7	1976	197	7	16	1974	0.00	-79.81
34	044077	HO	07	16	7	1977	198	7	17	1974	0.00	-72.74
35	044077	HO	07	08	7	1976	199	7	18	1974	0.00	-74.73
36	072290	HO	07	03	7	1976	200	7	13	1974	0.00	-69.46
37	044467	HO	07	04	7	1976	201	7	20	1974	0.00	-71.31
38	044488	HO	07	03	7	1976	202	7	21	1974	0.00	-74.67
39	044486	HO	07	03	7	1976	203	7	7	1974	0.00	-71.00
40	079067	HO	07	03	7	1976	204	7	23	1974	0.00	-86.56
41	079080	HO	10	16	7	1976	205	7	24	1974	0.00	-86.56
42	790002	HO	01	16	7	1976	206	7	25	1974	0.00	-86.56
43	790018	HO	11	15	7	1976	207	7	26	1974	0.00	-86.56
44	790018	HO	10	15	7	1976	208	7	27	1974	0.00	-86.56
45	044497	HO	07	03	7	1976	209	7	28	1974	0.00	-77.73
46	044489	HO	07	03	7	1976	210	7	29	1974	0.00	-74.69
47	790028	HO	09	14	7	1976	211	7	30	1974	0.00	-74.00
48	790005	HO	01	20	7	1976	212	7	31	1974	0.00	-81.00
49	079070	HO	07	22	7	1977	213	7	1	1974	0.00	-81.00
50	079036	HO	07	22	7	1977	214	7	8	1974	0.00	-84.71
51	044476	HO	07	03	7	1976	215	7	3	1974	0.00	-91.19

ORIGINAL PAGE IS OF POOR QUALITY

FEC	AC TAPE	PROC	CY	MN	DM	YEAR	F	LAT	Lon	E1	P1	BX
52	045680 HD	07/15/77	216	8	4	1974	6.62	-0.00	266.27	172548.16	.11	-108.38
53	79104	08/22/75	217	8	5	1974	-0.00	-0.00	-0.00	375871.95	.31	-0.00
54	79111	08/22/75	218	8	6	1974	-0.00	-0.00	-0.00	265396.49	.15	-0.00
INCONSISTENT DAYS												
55	79051	01/05/76	219	7	8	1974	-0.00	-0.00	-0.00	374645.62	.15	-0.00
56	79071	01/16/76	220	8	8	1974	-0.00	-0.00	-0.00	371686.03	.24	-0.00
57	79061	01/06/76	221	8	9	1974	-0.00	-0.00	-0.00	229097.35	.39	-0.00
INCONSISTENT DAYS												
58	79072	01/07/76	222	7	11	1974	-0.00	-0.00	-0.00	444538.67	.67	-0.00
59	079021 HD	07/03/76	223	8	11	1974	5.66	1.45	265.70	354704.03	.69	-81.00
60	044508 HD	07/09/76	224	8	12	1974	5.62	-0.00	266.28	445187.62	1.63	-70.31
61	044506 HD	07/13/76	225	8	13	1974	5.62	-0.00	266.28	411308.14	.64	-72.15
62	044514 HD	07/13/76	226	8	14	1974	5.62	-0.01	266.27	266409.82	.66	-73.13
63	79013	08/27/75	227	8	15	1974	-0.00	-0.00	-0.00	77744.06	.52	-0.00
64	79016	08/23/75	228	8	16	1974	-0.00	-0.00	-0.00	96853.35	.29	-0.00
65	79010	08/23/75	229	8	17	1974	-0.00	-0.00	-0.00	63726.26	.32	-0.00
66	79015	08/23/75	230	8	18	1974	-0.00	-0.00	-0.00	146682.93	.18	-0.00
67	79006	08/29/75	231	8	19	1974	-0.00	-0.00	-0.00	44163.20	.25	-0.00
68	044112 HD	07/13/76	232	8	20	1974	5.62	-0.11	266.24	-1.00	1.00	-0.00
69	79034	01/10/76	233	8	21	1974	-0.00	-0.00	-0.00	306733.62	16.55	-0.00
70	79000	09/02/75	234	8	22	1974	-0.00	-0.00	-0.00	397787.91	4.84	-0.00
71	79029	01/16/76	235	8	23	1974	-0.00	-0.00	-0.00	358250.70	4.93	-0.00
1 DAYS MISSING												
72	044468 HD	07/13/76	237	8	25	1974	5.62	-0.00	266.20	470375.66	.23	-76.59
73	79105	09/03/75	238	8	26	1974	-0.00	-0.00	-0.00	395616.03	.25	-0.00
74	79033	09/03/75	239	8	27	1974	-0.00	-0.00	-0.00	270603.26	.30	-0.00
1 DAYS MISSING												
75	79073	09/05/75	241	8	29	1974	-0.00	-0.00	-0.00	312098.70	.23	-0.00
76	79031	01/00/76	242	8	30	1974	-0.00	-0.00	-0.00	223023.74	.22	-0.00
77	79079	09/05/75	243	8	31	1974	-0.00	-0.00	-0.00	304081.01	.22	-0.00
78	044114 HD	07/13/76	244	8	1	1974	5.62	-0.09	266.57	-1.00	1.00	-0.00
79	044502 HD	07/13/76	245	8	2	1974	5.62	-0.01	266.14	-1.00	1.00	-0.00
80	079035 HD	07/23/77	246	8	3	1974	5.62	-0.01	265.80	236330.24	.35	-0.00
81	079054 HD	07/23/77	247	8	4	1974	5.62	-0.04	265.79	538105.33	.45	-0.00
82	079053 HD	07/13/76	248	8	5	1974	5.62	-0.00	265.78	403277.35	.22	-0.00
83	079182 HD	07/13/76	249	8	6	1974	5.62	-0.00	265.77	-1.00	1.00	-0.00
84	44013	11/05/75	250	8	7	1974	-0.00	-0.00	-0.00	-1.00	1.00	-0.00
85	044503 HD	07/14/76	251	8	8	1974	5.62	-0.07	266.05	386244.16	.28	-0.00
86	079026 HD	07/14/76	252	8	9	1974	5.62	-0.00	266.05	439337.60	.07	-0.00
87	044510 HD	07/16/77	253	8	9	1974	5.62	-0.00	265.72	405514.33	.19	-70.28
88	079024 HD	07/14/76	254	8	10	1974	5.62	-0.01	265.03	111034.91	.14	-0.00
89	079032 HD	07/14/76	255	8	11	1974	5.62	1.98	269.70	193774.38	.07	-0.00
90	079274 HD	08/11/77	256	8	12	1974	5.62	-0.07	265.67	169413.56	73.74	-71.63
					13	1974	5.62	-1.00	-1.00	-1.00	1.00	-1.00

REC	AC TAPE	PROC	DAY	MON	DOM	YEAR	F	LAT	LONG	E1	P1	BX
1 DAYS MISSING												
991	079118	HD	17	22	77	22	5	265.62	193477.07	311.68	-70.07	
992	079078	HD	19	16	77	22	5	265.59	-1.00	-1.00	-1.00	
993	008415	HD	10	21	77	22	5	265.99	-1.00	-1.00	-1.00	
994	079076	HD	09	16	77	22	5	265.55	366309.63	0.36	-82.48	
995	079275	HD	08	12	77	22	5	265.62	276590.36	-6.64	-1.00	
996	003097	HD	12	12	77	22	5	265.71	-1.00	-1.00	-1.00	
997	008189	HD	10	24	77	22	5	265.72	-1.00	-1.00	-1.00	
998	007241	HD	10	24	77	22	5	265.74	-1.00	-1.00	-1.00	
999	079276	HD	07	30	77	22	5	265.62	-1.00	-1.00	-1.00	
1000	079065	HD	08	11	77	22	5	265.62	503490.55	12.83	-1.00	
1001	79080		09	24	75	22	5	265.62	484144.58	47.81	-76.08	
1002	79063		09	24	75	22	5	265.62	345295.70	15.94	-0.00	
1003	79103		09	24	75	22	5	265.62	412267.45	11.94	-0.00	
1004	79059		09	26	75	22	5	265.62	214147.01	3.93	-0.00	
1005	79064		09	20	75	22	5	265.62	331782.73	2.58	-0.00	
1006	044018	HD	09	13	77	22	5	266.14	335650.28	1.17	-0.00	
1007	79066		09	23	75	22	5	265.62	349120.19	1.00	-78.12	
1008	44019		10	10	75	22	5	265.62	445649.40	1.91	-0.00	
1009	79102		10	10	75	22	5	265.62	443856.02	1.03	-0.00	
1010	79068		10	01	75	22	5	265.62	565021.21	1.17	-0.00	
1011	79074		10	02	75	22	5	265.62	440218.39	0.58	-0.00	
1012	44020		10	10	75	22	5	265.62	464313.08	0.56	-0.00	
1013	79056		10	06	75	22	5	265.62	227327.14	0.54	-0.00	
1014	044021	HD	10	06	75	22	5	265.62	396673.38	0.99	-0.00	
1015	79060		10	25	76	22	5	266.19	-1.00	-1.00	-1.00	
1016	79060		10	23	75	22	5	265.62	252130.75	0.41	-0.00	
1017	79056		10	23	76	22	5	265.62	271354.90	0.54	-0.00	
1018	79115		10	23	75	22	5	265.62	271465.55	0.41	-0.00	
1019	044022	HD	09	16	77	22	5	266.21	276254.73	0.38	-74.33	
1020	79062		10	23	75	22	5	265.62	44544.72	0.43	-0.00	
1021	79069		10	24	75	22	5	265.62	433781.35	0.30	-0.00	
1022	79055		10	27	75	22	5	265.62	314391.06	0.50	-0.00	
1023	79077		01	23	76	22	5	265.62	317367.95	0.14	-0.00	
1024	79106		11	27	76	22	5	265.62	339819.99	0.30	-0.00	
1025	44023		10	14	75	22	5	265.62	503086.53	0.17	-0.00	
1026	79154		10	23	75	22	5	265.62	463056.54	0.20	-0.00	
1027	044024	HD	09	10	77	22	5	266.17	320525.35	0.00	-86.50	
1028	79025		10	17	75	22	5	265.62	488788.71	0.27	-0.00	
1029	79016	HD	08	04	76	22	5	265.62	439545.79	0.23	-80.61	
1030	79075		10	20	75	22	5	265.62	282768.84	0.16	-0.00	
1031	79084		11	03	75	22	5	265.62	154970.75	0.22	-0.00	
1032	79111	HD	09	19	77	22	5	265.95	239503.83	0.18	-81.13	
1033	79080	HD	07	04	76	22	5	265.62	449808.91	0.16	-1.00	
1034	044025	HD	01	04	76	22	5	265.62	295690.83	0.21	-0.00	
1035	79096	HD	03	07	76	22	5	265.62	405932.52	0.21	-77.06	
1036	79083	HD	08	11	76	22	5	265.62	491581.81	0.24	-76.06	
1037	79074	HD	08	10	76	22	5	265.62	443188.66	0.17	-77.92	
1038	79081	HD	08	04	76	22	5	265.62	403352.76	0.27	-79.40	
1039	79074	HD	08	17	76	22	5	266.33	358523.63	0.21	-78.81	

REC	AC	TAPE	POC	DY	MN	DM	YEAR	R	LAT	LOX	E1	P1	BX	
139	044	475	HO	08/16/76	306	11	2	1974	0.62	.04	266.33	335130.75	.12	-73.48
140	044	560	HO	08/16/76	307	11	3	1974	0.62	-.00	266.33	341348.05	0.00	-72.76
141	044	481	HO	08/16/76	308	11	4	1974	0.62	-.08	266.33	210656.10	.41	-72.09
142	044	472	HO	08/16/76	309	11	5	1974	0.62	-.00	266.34	151642.77	.58	-74.31
143	079	181	HO	08/16/76	310	11	6	1974	0.62	-.02	266.03	68860.09	57.96	-64.47
144	044	591	HO	08/16/76	311	11	7	1974	0.62	-.01	266.34	248496.15	6.91	-72.59
145	044	467	HO	08/16/76	312	11	8	1974	0.62	-.00	266.35	194160.91	4.71	-72.87
146	044	482	HO	08/26/76	313	11	9	1974	0.62	.01	266.34	175574.66	3.24	-101.87
147	044	478	HO	08/16/76	314	11	10	1974	0.62	.01	266.35	441230.88	.45	-61.83
148	044	559	HO	08/27/76	315	11	11	1974	0.62	-.01	266.35	437675.13	.27	-72.44
149	044	471	HO	08/17/76	316	11	12	1974	0.62	-.00	266.35	175583.24	.13	-86.64
1 DAYS MISSING														
150	044	479	HO	08/17/76	318	11	14	1974	0.62	.00	266.33	405817.31	.74	-88.22
151	044	464	HO	08/17/76	319	11	15	1974	0.62	.03	266.33	476982.68	.21	-59.28
152	044	465	HO	08/17/76	320	11	16	1974	0.61	.30	266.34	458679.89	.33	-82.78
153	044	477	HO	08/17/76	321	11	17	1974	0.62	.01	266.32	405492.70	.09	-73.76
154	044	480	HO	08/18/76	322	11	18	1974	0.62	.00	266.32	324624.22	.30	-76.30
1 DAYS MISSING														
155	044	469	HO	08/19/76	324	11	20	1974	0.62	.81	266.39	192228.33	.28	-73.76
156	044	473	HO	08/18/76	325	11	21	1974	0.62	-.07	266.34	464626.40	.25	-74.02
157	044	549	HO	08/13/76	326	11	22	1974	0.62	-.00	266.34	479903.09	.13	-76.36
158	044	571	HO	08/13/76	327	11	23	1974	0.62	-.01	266.33	443183.25	.23	-76.58
159	044	555	HO	08/13/76	328	11	24	1974	0.62	-.01	266.30	388507.38	0.00	-67.14
160	044	590	HO	08/13/76	329	11	25	1974	0.62	-.05	266.29	479655.25	.23	-71.74
161	044	565	HO	08/12/76	330	11	26	1974	0.67	.21	266.47	507310.14	.19	-75.67
162	044	570	HO	08/12/76	331	11	27	1974	0.62	.13	266.29	415843.41	.24	-76.25
163	044	574	HO	08/12/76	332	11	28	1974	0.62	-.05	266.27	408851.22	.25	-75.90
164	044	550	HO	08/12/76	333	11	29	1974	0.62	-.01	266.26	377783.51	.22	-76.09
165	044	579	HO	08/12/76	334	11	30	1974	0.62	-.01	266.26	347948.61	.20	-76.60
166	044	556	HO	08/12/76	335	12	1	1974	0.62	-.01	266.22	318874.52	.14	-72.93
167	044	551	HO	09/16/77	336	12	2	1974	0.62	-.00	266.24	20892.60	.22	-73.25
INCONSISTENT DAYS														
168	044	586	HO	09/16/77	337	12	2	1974	0.62	-.08	266.22	172698.08	.26	-68.86
169	044	553	HO	09/16/77	338	12	4	1974	0.62	-.05	266.21	301782.59	.17	-73.04
170	044	588	HO	08/12/76	339	12	5	1974	0.62	-.02	266.20	342175.16	.17	-75.50
171	044	561	HO	09/16/77	340	12	6	1974	0.62	-.01	266.19	332433.87	.28	-73.97
172	044	557	HO	08/17/76	341	12	7	1974	0.62	-.00	266.17	331833.21	.29	-72.74
173	044	552	HO	08/09/76	342	12	8	1974	0.62	-.01	266.16	-1.00	-1.00	
174	044	578	HO	08/09/76	343	12	9	1974	0.62	.01	266.13	121828.48	.22	-58.80
175	044	548	HO	08/09/76	344	12	10	1974	0.62	-.01	266.13	402829.81	.25	-79.46
176	044	576	HO	08/10/76	345	12	11	1974	0.62	.02	266.10	464797.41	.31	-76.12
177	044	580	HO	08/10/76	346	12	12	1974	0.62	.01	266.09	488444.91	.29	-72.36
178	044	582	HO	08/10/76	347	12	13	1974	0.62	.00	266.07	484106.94	.21	-75.35
179	044	566	HO	08/10/76	348	12	14	1974	0.62	-.00	266.06	452058.00	.14	-72.12
180	044	567	HO	08/10/76	349	12	15	1974	0.62	-.02	266.05	425144.51	.27	-73.19

REC	AC	TAPE	PROC	CY	MN	DM	YEAR	R	LAT	LON	E1	P1	BX
181	0	44	562	HD	08	10	1974	6	.00	266.04	418429.30	.22	-80.18
182	0	44	564	HD	08	10	1974	6	.01	266.02	433213.02	.22	-73.89
183	0	44	564	HD	08	10	1974	6	-.04	266.00	197072.70	.24	-88.15
184	0	44	583	HD	08	10	1974	6	-.04	265.98	446827.10	.27	-73.49
185	0	44	568	HD	08	18	1974	6	-.00	265.95	439875.43	.43	-75.78
186	0	44	581	HD	08	11	1974	6	-.00	265.98	484229.43	.35	-75.75
187	0	44	573	HD	08	11	1974	6	-.00	265.91	435579.10	.29	-78.33
188	0	44	569	HD	08	11	1974	6	-.01	265.89	421073.71	1.62	-74.08
189	0	44	563	HD	08	18	1974	6	-.01	265.85	440262.45	.14	-77.62
190	0	44	585	HD	08	11	1974	6	-.01	265.83	430097.64	.09	-73.06
191	0	44	577	HD	08	11	1974	6	-.01	265.82	487208.13	.48	-77.69
192	0	44	572	HD	08	11	1974	6	.04	265.78	250548.50	1.43	-68.80
193	0	44	587	HD	08	11	1974	6	.05	265.76	399798.57	.52	-74.53
194	0	44	575	HD	08	11	1974	6	-.01	265.75	346259.20	.13	-72.74
195	0	44	554	HD	08	11	1974	6	-.07	265.70	248777.51	.11	-66.45
196	0	44	589	HD	08	13	1974	6	-.02	265.68	129131.51	.23	-59.01
197	0	44	599	HD	08	12	1975	6	-.10	265.82	205499.62	.24	-66.07
198	0	45	741	HD	08	12	1975	6	-.01	265.83	231734.51	.24	-73.51
199	0	44	602	HD	10	15	1975	6	.01	265.60	198736.60	.24	-71.89
200	0	44	604	HD	10	15	1975	6	.00	265.57	84993.02	.24	-47.44

INCONSISTENT DAYS

201	0	44	607	HD	10	15	1975	6	.02	265.54	374778.87	.24	-66.10
202	0	44	600	HD	10	15	1975	6	.00	265.88	535716.17	.22	-70.55
203	0	44	601	HD	08	26	1975	6	-.01	265.89	514420.20	25.81	-80.53
204	0	79	907	HD	08	26	1975	6	-.01	265.91	443524.37	1.57	-85.46
205	0	79	906	HD	08	30	1975	6	-.01	265.92	372243.43	.37	-75.59
206	0	44	608	HD	08	26	1975	6	-.01	265.93	390806.88	.17	-75.78
207	0	45	753	HD	08	12	1975	6	.00	265.95	370793.70	.19	-74.73
208	0	79	912	HD	08	12	1975	6	-.00	265.94	329054.30	.20	-72.90
209	0	44	611	HD	08	27	1975	6	-.01	265.29	178754.59	.30	-65.14
210	0	44	610	HD	08	27	1975	6	.00	265.98	352142.44	.25	-73.69
211	0	44	603	HD	08	27	1975	6	-.02	265.99	462450.72	.17	-73.54
212	0	44	606	HD	08	27	1975	6	-.03	266.00	386122.20	.21	-81.10
213	0	44	605	HD	08	27	1975	6	-.01	265.16	493040.86	.26	-78.67
214	0	44	609	HD	08	27	1975	6	.00	265.99	506197.00	.31	-78.39
215	0	44	596	HD	08	27	1975	6	.01	266.00	495900.93	.27	-79.29
216	0	44	597	HD	08	26	1975	6	-.00	266.00	453144.40	.15	-74.88
217	0	44	599	HD	08	26	1975	6	-.01	266.03	410485.40	.30	-71.12
218	0	44	594	HD	08	26	1975	6	-.00	266.01	316501.41	.22	-75.40
219	0	44	598	HD	08	26	1975	6	.00	266.05	173871.78	.33	-74.32
220	0	79	922	HD	08	26	1975	6	-.00	266.02	240040.18	.34	-62.83
221	0	79	914	HD	08	26	1975	6	.01	266.03	357772.82	.33	-82.48
222	0	79	908	HD	12	22	1975	6	.00	266.03	269972.44	.19	-68.43
223	0	79	923	HD	08	12	1975	6	-.02	266.03	148850.32	.10	-69.73
224	0	79	922	HD	08	12	1975	6	-.01	266.03	296940.14	.42	-67.29
225	0	79	925	HD	09	01	1975	6	.00	266.03	391727.83	.28	-71.89

INCONSISTENT DAYS

ORIGINAL PAGE IS
 OF POOR QUALITY

REC	AC	TAPE	PROC	DY	MN	DM	YEAR	P	LAT	LON	E1	P1	BX	
226	0	79908	HD	08/30/76	30	1	29	1975	5.62	- .01	266.03	175790.89	.30	-69.35
227	0	79924	HD	08/30/76	30	1	31	1975	6.62	.01	266.01	168005.58	.21	-70.17
228	0	79931	HD	10/17/76	32			1975	6.62	.53	266.10	2226372.52	.15	-64.91
229	0	79930	HD	12/01/76	33			1975	6.62	.07	266.01	539794.96	.22	-66.38
230	0	79911	HD	12/01/76	34			1975	6.62	.01	266.00	450084.56	.27	-70.72
231	0	79917	HD	12/01/76	35			1975	6.62	.00	266.00	428425.60	.32	-70.04
232		79902		11/25/75	36			1975	0.00	-0.00	0.00	333090.18	.32	-0.00
233		79913		11/26/75	37			1975	0.00	-0.00	0.00	455966.10	.13	-0.00
234		79910		11/26/75	38			1975	0.00	-0.00	0.00	394385.82	.23	-0.00
235		79921		12/12/75	39			1975	0.00	-0.00	0.00	342731.38	.29	-0.00
236		79923		12/01/75	40			1975	0.00	-0.00	0.00	252671.59	.29	-0.00
237		79918		12/02/75	41	10		1975	0.00	-0.00	0.00	334136.90	1.31	-0.00
238		79915		12/03/75	42	11		1975	0.00	-0.00	0.00	470650.51	.21	-0.00
239		79920		12/03/75	43	12		1975	0.00	-0.00	0.00	380537.91	.48	-0.00
240		79919		12/09/75	44	13		1975	0.00	-0.00	0.00	515969.92	.66	-0.00
241		44086		12/12/75	45	14		1975	0.00	-0.00	0.00	490923.65	.31	-0.00
242		44089		01/15/76	46	15		1975	0.00	-0.00	0.00	468032.55	.26	-0.00
243		44087		12/15/75	47	16		1975	0.00	-0.00	0.00	372130.19	.25	-0.00
244		44098		12/16/75	48	17		1975	0.00	-0.00	0.00	532459.27	.27	-0.00
245		44092		12/16/75	49	18		1975	0.00	-0.00	0.00	386040.19	.29	-0.00
246		79932		12/19/75	50	19		1975	0.00	-0.00	0.00	359087.60	.23	-0.00
247		44100		12/17/75	51	20		1975	0.00	-0.00	0.00	385138.12	.27	-0.00
248		79933		12/17/75	52	21		1975	0.00	-0.00	0.00	269085.81	.17	-0.00
249		44088		12/19/75	53	22		1975	0.00	-0.00	0.00	180968.54	.21	-0.00
250		44085		12/23/75	54	23		1975	0.00	-0.00	0.00	111793.22	.26	-0.00
251		44093		12/29/75	55	24		1975	0.00	-0.00	0.00	233753.85	.25	-0.00
252		44091		12/29/75	56	25		1975	0.00	-0.00	0.00	387384.00	.24	-0.00
253		44084		12/31/75	57	26		1975	0.00	-0.00	0.00	165684.93	.18	-0.00
254		44094		12/31/75	58	27		1975	0.00	-0.00	0.00	380859.79	.23	-0.00
255	0	44099	HD	01/02/76	59	28		1975	6.62	.00	265.92	326599.65	.34	-0.00
256		44090		06/25/76	60	29		1975	6.62	.06	265.92	63996.90	.23	-0.27
257		44095		01/02/76	61	30		1975	0.00	-0.00	0.00	369630.60	.23	-0.00
258		44096		01/02/76	62	31		1975	0.00	-0.00	0.00	417218.00	.30	-0.00
259		44097		01/05/76	63	32		1975	0.00	-0.00	0.00	296946.00	.35	-0.00
260		- 0		01/08/76	64	33		1975	0.00	-0.00	0.00	246077.59	.22	-0.00
261		44104		01/08/76	65	34		1975	0.00	-0.00	0.00	470892.53	.27	-0.00
262		44105		01/09/76	66	35		1975	0.00	-0.00	0.00	518922.70	.29	-0.00
263		44102		01/09/76	67	36		1975	0.00	-0.00	0.00	520610.59	.14	-0.00
264		44107		01/09/76	68	37		1975	0.00	-0.00	0.00	448823.80	.19	-0.00
265		44106		01/12/76	69	38	10	1975	0.00	-0.00	0.00	255270.88	.29	-0.00
266		44108		01/12/76	70	39	11	1975	0.00	-0.00	0.00	247483.30	.29	-0.00
267		44101		01/12/76	71	40	12	1975	0.00	-0.00	0.00	573748.10	1.30	-0.00
268		44109		01/13/76	72	41	13	1975	0.00	-0.00	0.00	558354.66	.55	-0.00
269		44063		11/10/75	73	42	14	1975	0.00	-0.00	0.00	564907.51	.27	-0.00
270		44069		11/12/75	74	43	15	1975	0.00	-0.00	0.00	578804.47	.68	-0.00
271		44068		11/12/75	75	44	16	1975	0.00	-0.00	0.00	410871.89	.32	-0.00
272		44070		11/12/75	76	45	17	1975	0.00	-0.00	0.00	364881.89	.46	-0.00
273		44065		11/13/75	77	46	18	1975	0.00	-0.00	0.00	407484.10	.30	-0.00
274		44110		01/13/76	78	47	19	1975	7.00	-0.00	0.00	414484.87	.37	-0.00
275		44072		11/14/75	79	48	20	1975	0.00	-0.00	0.00	368707.63	.84	-0.00
276		44073		11/17/75	80	49	21	1975	0.00	-0.00	0.00	384986.25	.41	-0.00

REC	AC TAPE	PROC	CY	MN	DM	YEAR	R	LAT	Lon	E1	P1	BX
277	44067		81	3	22	1975	-0.00	-0.00	-0.00	412863.66	.21	-0.00
278	44066		82	3	23	1975	-0.00	-0.00	-0.00	182544.53	.30	-0.00
279	44071		83	3	24	1975	-0.00	-0.00	-0.00	294387.76	.21	-0.00
280	44064		84	3	25	1975	-0.00	-0.00	-0.00	321174.21	.28	-0.00
281	0 44691	HO	85	3	26	1975	6.62	0.01	265.96	343368.49	.17	-69.60
282	0 44620	HO	86	3	27	1975	6.62	.01	265.96	242828.35	.22	-72.85
283	0 44622	HO	87	3	28	1975	6.62	.01	265.94	330929.59	.15	-82.72
284	0 44614	HO	88	3	29	1975	6.62	.00	265.94	499285.39	.11	-76.72
285	0 44627	HO	89	3	30	1975	6.62	.02	265.94	496968.18	.32	-77.63
286	0 44612	HO	90	3	31	1975	6.62	.00	265.93	414037.24	.26	-71.81
287	0 44677	HO	91	4	1	1975	6.62	.00	265.91	424984.58	.27	-72.18
288	0 44637	HO	92	4	2	1975	6.62	.16	266.08	382846.10	.25	-73.37
289	0 44613	HO	93	4	3	1975	6.62	-.06	265.90	240604.08	.32	-67.71

INCONSISTENT DAYS

290	0 44692	HO	94	4	3	1975	6.62	-.01	265.89	217653.96	.25	-68.16
291	0 44629	HO	95	4	4	1975	6.62	-.03	265.88	137305.47	.14	-79.17
292	0 44628	HO	96	4	5	1975	6.62	.01	265.87	195656.36	.27	-71.51
293	0 44626	HO	97	4	7	1975	6.62	-.00	265.86	382916.38	.18	-79.89
294	0 44660	HO	98	4	8	1975	6.62	.20	265.86	456281.58	4.32	-85.39
295	0 44621	HO	99	4	9	1975	6.62	.03	265.84	443240.11	.26	-85.00
296	0 44618	HO	100	4	10	1975	6.62	.00	265.83	319857.51	.16	-90.82
297	0 44633	HO	101	4	11	1975	6.62	.02	265.81	528828.91	.41	-79.32
298	0 44624	HO	102	4	12	1975	6.62	.01	265.80	439955.44	.26	-52.67
299	0 44632	HO	103	4	13	1975	6.62	-.01	265.77	465620.53	.18	-92.52
300	0 44619	HO	104	4	14	1975	6.62	-.02	265.78	492650.26	.21	-77.09
301	0 44631	HO	105	4	15	1975	6.62	-.01	265.74	467650.35	.26	-79.85
302	0 44693	HO	106	4	16	1975	6.62	-.02	265.72	371240.02	.25	-77.13
303	0 44625	HO	107	4	17	1975	6.62	.01	265.71	-1.00	-1.00	-1.00
304	0 44634	HO	108	4	18	1975	6.62	.00	265.69	-1.00	-1.00	-1.00
305	0 44630	HO	109	4	19	1975	6.62	-.01	265.68	164128.61	.07	-72.11
306	0 44617	HO	110	4	20	1975	6.62	.01	265.66	166329.99	.07	-69.30
307	0 44615	HO	111	4	21	1975	6.62	.01	265.64	321133.60	.28	-84.64

INCONSISTENT DAYS

308	0 44619	HO	112	4	21	1975	6.62	-.01	265.62	395521.66	.38	-74.41
309	0 44642	HO	113	4	23	1975	6.62	-.02	265.60	457330.05	.29	-75.56
310	0 44643	HO	114	4	24	1975	6.62	-.01	265.57	413952.33	.18	-74.68
311	0 44635	HO	115	4	25	1975	6.62	.00	265.55	425094.68	.22	-73.43
312	0 44653	HO	116	4	26	1975	6.62	-.01	265.53	405286.92	.42	-77.77
313	0 44641	HO	117	4	27	1975	6.62	-.00	265.51	407047.76	.36	-71.89
314	0 44665	HO	118	4	28	1975	6.62	.01	265.49	424333.52	.20	-70.73
315	0 44645	HO	119	4	29	1975	6.62	.01	265.47	357733.22	.17	-70.12
316	0 44644	HO	120	4	30	1975	6.62	-.00	265.96	281182.78	.23	-69.50
317	0 44646	HO	121	4	31	1975	6.62	.05	265.97	65579.68	.28	-67.34
318	0 44699	HO	122	4	2	1975	6.62	.00	265.97	130344.42	.34	-68.18
319	0 44638	HO	123	4	3	1975	6.62	.00	265.98	267255.50	.33	-82.92
320	0 44647	HO	124	4	4	1975	6.62	-.00	265.98	337044.91	.17	-82.79
321	0 44647	HO	125	4	5	1975	6.62	-.06	265.98	118721.34	.33	-105.87

REC	AC	TAPE	PROC	DY	MN	DM	YEAR	R	LAT	LON	E1	P1	BX	
322	044	666	HD	10/01/76	126	5	6	1975	6.62	-.00	265.98	443652.37	.43	-96.77
323	044	659	HD	10/01/76	127	5	7	1975	6.62	-.00	265.98	548863.68	.35	-80.18
324	044	690	HD	10/01/76	128	5	8	1975	6.62	-.03	265.97	434500.28	.29	-81.01
325	044	673	HD	10/01/76	129	5	9	1975	6.62	-.01	265.98	427573.47	.23	-83.12
326	044	648	HD	10/01/76	130	5	10	1975	6.62	-.02	265.99	512514.18	15.33	-83.00
327	044	694	HD	09/27/76	131	5	11	1975	6.64	-.15	266.09	482900.57	0.00	-76.86
328	044	636	HD	09/27/76	132	5	12	1975	6.62	-.00	265.98	483583.68	.24	-74.33
329	044	639	HD	09/27/76	133	5	13	1975	6.62	-.01	265.98	441624.68	1.00	-73.29
330	044	675	HD	09/27/76	134	5	14	1975	6.62	-.00	265.98	382833.73	.10	-88.38
331	044	654	HD	09/27/76	135	5	15	1975	6.62	-.01	265.98	366433.45	.28	-73.56
332	044	697	HD	10/12/76	136	5	16	1975	6.62	-.02	265.98	382182.52	.30	-72.63
333	044	640	HD	10/02/76	137	5	17	1975	6.62	-.01	265.98	333241.66	.86	-82.30
334	044	667	HD	10/02/76	138	5	18	1975	6.62	-.01	265.97	-1.00	-1.00	-1.00
335	044	695	HD	10/02/76	139	5	19	1975	6.62	-.00	265.97	-1.00	-1.00	-1.00

1 DAYS MISSING

336	044	655	HD	10/02/76	141	5	21	1975	6.57	-.02	266.42	422816.19	.18	-73.72
337	044	656	HC	10/23/76	142	5	22	1975	6.57	-.01	270.01	344328.01	.28	-74.16
338	044	649	HD	12/22/76	143	5	23	1975	6.57	-.00	273.53	488359.13	.30	-76.82
339	044	663	HD	10/11/76	144	5	24	1975	6.58	-.01	276.88	394258.52	.32	-78.79
340	044	687	HD	10/11/76	145	5	25	1975	6.58	-.01	280.09	-1.00	-1.00	-1.00
341	044	668	HD	10/11/76	146	5	26	1975	6.57	-.02	285.71	251660.62	.28	-106.65
342	044	670	HD	10/11/76	147	5	27	1975	6.57	-.02	289.58	410205.15	.27	-89.65
343	044	662	HD	10/11/76	148	5	28	1975	6.57	-.00	293.40	174931.58	.28	-93.70
344	044	680	HD	10/11/76	149	5	29	1975	6.57	.01	297.33	231926.58	.25	-76.38

INCONSISTENT DAYS

345	044	688	HD	10/02/76	150	5	29	1975	6.57	-.03	301.17	311199.51	.57	-80.55
346	044	682	HD	10/02/76	151	5	31	1975	6.57	-.00	305.05	254372.39	.33	-80.54
347	044	651	HD	10/02/76	152	5	1	1975	6.57	-.03	308.76	238526.03	.32	-75.98
348	044	684	HD	10/02/76	153	6	2	1975	6.57	-.01	312.73	107993.69	.26	-111.34
349	044	652	HD	10/02/76	154	6	3	1975	6.57	-.00	316.81	477283.25	3.47	-95.15
350	044	658	HD	10/02/76	155	6	4	1975	6.57	-.00	320.45	453601.61	.32	-80.46
351	044	685	HD	10/11/76	156	6	5	1975	6.57	-.04	324.24	417142.77	.32	-77.64
352	044	657	HD	10/11/76	157	6	6	1975	6.57	-.00	328.13	369349.86	.29	-79.79
353	044	650	HD	10/11/76	158	6	7	1975	6.57	-.00	331.97	416940.86	.25	-71.30
354	044	623	HD	10/11/76	159	6	8	1975	6.57	-.00	335.81	397944.29	.17	-66.34
355	044	689	HD	10/11/76	160	6	9	1975	6.57	-.01	339.67	333511.00	.25	-60.26
356	044	676	HD	10/11/76	161	6	10	1975	6.57	-.03	343.54	291976.96	.28	-58.15
357	044	674	HD	10/11/76	162	6	11	1975	6.57	-.03	347.38	207683.46	.34	-59.39
358	044	683	HD	10/11/76	163	6	12	1975	6.57	-.01	351.18	157127.73	.25	-69.58
359	044	681	HD	10/11/76	164	6	13	1975	6.57	-.05	355.15	441030.03	1.57	-52.53

INCONSISTENT DAYS

360	044	686	HD	10/11/76	165	6	13	1975	6.57	.05	358.65	462836.25	1.04	-43.64
361	044	678	HC	10/11/76	166	6	15	1975	6.57	.03	2.68	425271.86	1.12	-47.25
362	044	661	HD	10/11/76	167	6	16	1975	6.57	-.14	6.74	349774.84	.35	-45.85
363	044	679	HD	10/12/76	168	6	17	1975	6.57	.12	10.42	522746.80	.23	-3.24

REC	AC	TAPE	PROC	BY	MN	DM	YEAR	R	LAT	LON	E1	P1	BX		
364	044	671	HD	10/13/76	16	9	6	18	1975	6.57	-03	14.29	510240.94	.22	-30.85
365	044	737	HD	10/15/76	170		19	1975	6.57	-05	14.24	479122.25	.45	-25.87	
366	044	772	HD	10/15/76	171		20	1975	6.57	-02	14.05	500329.38	.34	-16.42	
367	044	748	HD	10/15/76	172		21	1975	6.57	-11	22.62	462225.09	.20	-18.91	
368	045	742	HD	08/11/77	173		22	1975	6.59	.00	28.49	448558.89	.23	-7.77	
369	044	771	HD	12/04/76	174		23	1975	6.59	.08	29.64	431213.41	.24	-6.27	
370	044	756	HD	12/04/76	175		24	1975	6.59	.01	33.06	346850.67	.27	-4.35	
371	045	745	HD	08/11/77	176		25	1975	6.59	.37	37.57	332461.74	.24	-1.47	
372	044	767	HD	10/17/76	177		26	1975	6.57	.06	45.24	200337.07	.24	-1.01	
373	044	781	HD	10/17/76	178		27	1975	6.61	-05	34.43	319648.56	.21	-3.06	
374	044	766	HD	10/17/76	179		28	1975	6.57	.00	32.95	247898.79	.19	6.09	
375	044	742	HD	10/17/76	180		29	1975	6.62	-05	33.44	208160.98	.26	-1.12	
376	044	735	HD	10/17/76	181		30	1975	6.62	-01	33.16	278736.18	.33	-7.66	
377	044	736	HD	10/17/76	182		31	1975	6.62	.83	35.15	477758.09	.29	-1.38	
378	044	723	HD	12/04/76	183		32	1975	6.62	-01	35.14	332813.98	.22	-1.95	
379	044	776	HD	12/04/76	184		33	1975	6.62	.03	35.11	358841.61	.25	-4.13	
380	044	750	HD	12/04/76	185		34	1975	6.62	.03	35.08	406355.26	.20	-1.01	
381	044	754	HD	11/03/76	186		35	1975	6.62	.02	35.06	399538.49	.37	-1.89	
382	044	746	HD	11/24/76	187		36	1975	6.62	.00	35.04	326541.33	.27	-1.38	
383	044	773	HD	12/04/76	188		37	1975	6.62	.00	35.02	312972.83	.40	-1.41	
384	044	758	HD	10/13/76	189		38	1975	6.62	-01	35.00	20145.46	.30	-2.36	
385	044	770	HD	10/13/76	190		39	1975	6.62	-01	35.11	354017.53	.33	-7.47	
386	044	753	HD	10/13/76	191		40	1975	6.62	-05	35.06	395592.84	.27	-2.25	
387	044	760	HD	10/13/76	192		41	1975	6.62	.00	35.09	589851.51	.53	-2.06	
388	044	725	HD	10/13/76	193		42	1975	6.62	-01	35.04	498744.46	.18	3.31	
389	044	762	HD	10/13/76	194		43	1975	6.62	.62	34.81	460947.00	.24	3.39	
390	044	755	HD	10/17/76	195		44	1975	6.62	-01	34.91	328167.82	.32	-4.41	
391	044	726	HD	10/17/76	196		45	1975	6.62	-00	34.90	590496.94	.27	-14.51	
392	044	765	HD	10/17/76	197		46	1975	6.62	-01	34.90	494291.27	.24	-2.58	
393	044	739	HD	10/17/76	198		47	1975	6.62	.17	34.89	487092.38	.25	-1.86	
394	044	751	HD	10/17/76	199		48	1975	6.62	.01	34.89	586407.29	.29	-1.10	
395	044	782	HD	10/17/76	200		49	1975	6.62	.01	34.89	412781.43	.29	-4.60	
396	044	749	HD	10/15/76	201		50	1975	6.62	-01	34.90	486765.48	.26	-3.33	
397	044	672	HD	10/15/76	202		51	1975	6.62	-01	34.90	478843.41	.23	1.60	
398	044	729	HD	10/15/76	203		52	1975	6.62	.00	34.91	324207.24	.33	-1.11	
399	044	738	HD	10/15/76	204		53	1975	6.62	.00	34.92	297959.42	.34	1.90	
400	045	743	HD	08/13/77	205		54	1975	6.62	.13	34.91	365340.14	.30	1.42	
401	044	733	HD	10/15/76	206		55	1975	6.62	.00	34.95	395222.71	.17	-4.67	
402	044	728	HD	10/25/76	207		56	1975	6.62	.00	34.96	471126.07	.29	-2.24	
403	044	783	HD	10/25/76	208		57	1975	6.62	-05	34.97	529280.61	.30	-2.96	
404	044	764	HD	10/25/76	209		58	1975	6.62	.00	34.98	535654.86	.22	-2.42	
405	044	752	HD	12/17/76	210		59	1975	6.62	.00	35.01	479550.35	.14	2.28	
406	044	730	HD	12/17/76	211		60	1975	6.62	.01	35.03	455641.14	.23	-7.74	
407	044	775	HD	12/17/76	212		61	1975	6.62	.05	35.05	405102.20	.29	-2.32	
408	044	759	HD	10/22/76	213		62	1975	6.62	.16	35.08	121904.48	.22	-1.20	
409	044	731	HD	10/22/76	214		63	1975	6.62	.00	35.11	270390.64	.17	4.28	
410	044	763	HD	10/22/76	215		64	1975	6.62	.02	35.14	88845.35	.28	-1.69	
411	045	767	HD	08/13/77	216		65	1975	6.62	.00	35.14	206990.93	.17	-2.42	
412	044	724	HD	08/13/77	217		66	1975	6.62	.00	35.18	80178.91	.33	-1.81	
413	044	747	HD	10/15/76	218		67	1975	6.62	.06	35.04	487976.78	.17	-1.15	
414	044	777	HD	11/30/76	219		68	1975	6.62	.12	35.03	481827.88	.32	5.40	

ORIGINAL PAGE IS
OF POOR QUALITY

FEC	AC	TAPE	PROC	DY	MN	DM	YEAR	F	LAT	LON	E1	P1	BX	
415	044	745	HO	12/04/76	22	08	9	1975	0.00	34.01	546516.73	.23	-	.64
416	044	774	HO	10/15/76	22	08	9	1975	0.01	34.99	168224.04	.27	-	.25
417	044	732	HO	11/30/76	22	08	10	1975	0.01	34.98	437992.21	.29	-	.98
418	044	757	HO	10/22/76	22	08	11	1975	0.01	34.97	521520.80	.25	-	.21
419	044	740	HO	10/22/76	22	08	12	1975	0.00	34.96	4571107.73	.23	-	.00
420	044	744	HO	10/22/76	22	08	13	1975	0.38	34.94	466090.26	.25	-	.47
421	044	778	HO	10/22/76	22	08	14	1975	0.02	34.93	303096.64	.23	-	.06
422	044	779	HO	10/22/76	22	08	15	1975	0.07	34.94	4622263.56	.29	-	.33
423	044	761	HO	10/22/76	22	08	16	1975	0.01	34.94	5382278.54	.23	-	.43
424	044	763	HO	12/04/76	22	08	17	1975	0.01	34.95	516952.38	.37	-	.38
425	044	763	HO	11/04/76	23	08	18	1975	0.00	34.94	437535.36	.14	-	.21
426	044	837	HO	11/23/76	23	08	19	1975	0.01	34.96	452829.54	.27	-	.44
427	044	868	HO	11/23/76	23	08	20	1975	0.00	34.97	387429.66	.29	-	.04

1 DAYS MISSING

428	044	858	HO	11/23/76	23	08	22	1975	0.02	34.96	388810.50	.6	55	2	52
429	044	851	HO	12/04/76	23	08	23	1975	0.01	34.99	520241.03	2	.43	1	52
430	044	849	HO	11/22/76	23	08	24	1975	0.00	34.99	503419.72	.42	.26	2	66
431	044	839	HO	09/11/77	23	08	25	1975	0.00	34.99	484556.22	.28	.7	7	83
432	044	836	HO	11/13/76	23	08	26	1975	0.22	34.92	320555.13	.42	.83	7	32
433	044	867	HO	12/04/76	23	08	27	1975	0.01	34.96	374724.03	.13	.32	4	32
434	044	865	HO	12/04/76	23	08	28	1975	0.11	34.95	338849.12	.24	.44	5	44
435	044	844	HO	11/13/76	23	08	29	1975	0.00	34.95	196659.44	.20	.36	1	46
436	044	861	HO	08/12/77	23	08	30	1975	0.01	34.99	311356.95	.29	.38	2	38
437	044	845	HO	11/23/76	23	08	31	1975	0.02	34.95	491482.78	.18	.30	4	33
438	044	838	HO	11/23/76	23	08	31	1975	0.00	34.95	411688.50	.32	.7	7	30
439	044	846	HO	12/03/76	23	08	31	1975	0.00	34.95	177249.20	.31	.43	2	43
440	044	744	HO	08/12/77	23	08	31	1975	0.00	34.95	173552.26	.21	.33	3	33
441	044	872	HO	11/23/76	23	08	4	1975	0.27	34.95	180654.73	.29	.16	8	16
442	044	848	HO	08/12/77	23	08	5	1975	0.02	34.95	188021.54	.23	.75	8	75
443	044	853	HO	11/23/76	23	08	6	1975	0.02	34.95	191848.95	.38	.13	8	13
444	044	841	HO	11/23/76	23	08	7	1975	0.07	34.95	142488.42	.34	.88	5	88
445	044	842	HO	12/04/76	23	08	8	1975	0.00	34.95	455934.71	.28	.8	1	8
446	044	847	HO	12/04/76	23	08	9	1975	0.01	34.95	476737.51	.21	.72	1	72
447	044	843	HO	11/22/76	23	08	10	1975	0.02	34.99	610180.62	.18	.71	1	71
448	044	840	HO	12/04/76	23	08	11	1975	0.00	34.98	572249.96	.23	.07	1	07
449	044	873	HO	08/12/77	23	08	12	1975	0.00	34.97	581414.11	.29	.66	2	66
450	044	871	HO	08/12/77	23	08	13	1975	0.08	34.97	581414.11	.29	.66	2	66
451	044	864	HO	12/04/76	23	08	14	1975	0.01	34.99	396397.21	.18	.57	1	57
452	044	859	HO	12/04/76	23	08	15	1975	0.00	34.99	461867.22	.17	.69	1	69
453	044	863	HO	12/04/76	23	08	16	1975	0.01	34.99	446779.47	.20	.03	1	03
454	044	860	HO	11/13/76	23	08	17	1975	0.01	34.99	347907.52	.22	.41	1	41
455	044	855	HO	11/13/76	23	08	18	1975	0.00	34.99	144223.09	.22	.03	1	03
456	044	866	HO	12/04/76	23	08	19	1975	0.00	34.99	168697.93	.30	.74	1	74
457	044	855	HO	12/10/76	23	08	20	1975	0.09	34.99	416682.46	.40	.15	1	15
458	044	857	HO	12/10/76	23	08	21	1975	0.02	34.99	443157.43	.21	.46	1	46
459	044	854	HO	12/10/76	23	08	22	1975	0.01	34.99	416886.26	.27	.11	1	11
460	044	862	HO	12/10/76	23	08	23	1975	0.04	34.99	289560.20	.24	.17	1	17
461	044	870	HO	12/11/76	23	08	24	1975	0.02	34.99	251788.82	.19	.77	1	77
462	044	874	HO	12/11/76	23	08	25	1975	0.00	34.99	204861.93	.29	.39	1	39

REC	AC TAPE	PROC	DY	MN	DM	YEAR	R	LAT	LON	E1	P1	BX	
463	045746	HD	08/12/77	269	9	26	1975	6.62	-.03	35.16	85009.46	.25	-6.55
464	044530	HD	07/01/76	270	9	27	1975	6.62	.01	35.19	315836.97	.26	-1.99
INCONSISTENT DAYS													
465	044527	HD	07/01/76	271	9	27	1975	6.62	-.02	36.07	203045.20	.19	4.85
466	044531	HD	07/01/76	272	9	27	1975	6.62	-.00	35.19	434595.59	.24	-1.18
467	044526	HD	07/01/76	273	9	27	1975	6.62	-.00	35.16	277777.00	.34	-4.68
468	044534	HD	06/30/76	274	10	1	1975	6.62	-.01	35.14	183972.56	.23	-2.44
469	044535	HD	06/30/76	275	10	2	1975	6.62	-.02	35.11	111355.29	.21	-4.57
470	044533	HD	06/30/76	276	10	3	1975	6.62	-.04	35.08	74471.93	.29	-2.91
471	044519	HD	06/30/76	277	10	4	1975	6.62	-.00	35.07	137217.61	.32	-1.26
472	044525	HD	07/01/76	278	10	5	1975	6.62	-.00	35.05	368313.27	.35	-1.12
473	044463	HD	07/01/76	279	10	6	1975	6.62	-.00	35.03	248866.49	.20	-1.96
474	044532	HD	07/01/76	280	10	7	1975	6.62	-.00	35.02	215650.09	.29	-8.45
475	044529	HD	07/01/76	281	10	8	1975	6.62	-.03	35.00	647527.21	.35	-6.71
476	044902	HD	12/23/76	282	10	9	1975	6.62	-.03	34.99	565493.25	.33	-10.42
477	044912	HD	12/22/76	283	10	10	1975	6.62	-.02	34.98	608674.88	1.24	-2.21
478	044916	HD	12/22/76	284	10	11	1975	6.62	.01	34.97	561386.26	.43	-6.81
1 DAYS MISSING													
479	044914	HD	12/22/76	286	10	13	1975	6.62	-.02	34.96	509650.19	.32	-6.79
480	045766	HD	08/15/77	287	10	14	1975	6.62	-.01	34.96	451895.71	.30	-2.59
481	044869	HD	12/21/76	288	10	15	1975	6.62	-.01	34.96	330499.29	.19	-1.82
482	044911	HD	12/21/76	289	10	16	1975	6.62	-.00	34.97	1066057.23	.21	-10.33
483	044528	HD	12/21/76	290	10	17	1975	6.62	-.04	34.97	2996648.18	.25	-7.13
484	044913	HD	12/22/76	291	10	18	1975	6.62	-.00	34.97	379198.32	.28	-2.75
485	044917	HD	12/22/76	292	10	19	1975	6.62	-.01	34.98	194041.71	.21	-1.28
486	044915	HD	12/22/76	293	10	20	1975	6.62	-.03	35.02	60475.36	.55	-12.21
487	044893	HD	12/22/76	294	10	21	1975	6.62	-.01	35.03	89995.70	.58	-17.43
488	044891	HD	12/22/76	295	10	22	1975	6.62	-.01	35.04	73391.01	.29	-1.82
489	044918	HD	12/22/76	296	10	23	1975	6.62	-.10	35.07	92109.50	.21	-4.21
490	044905	HD	12/22/76	297	10	24	1975	6.62	-.04	35.08	25407.59	.31	-2.53
491	044897	HD	12/22/76	298	10	25	1975	6.62	-.01	35.14	66278.10	.29	-1.53
492	044910	HD	12/22/76	299	10	26	1975	6.62	-.01	35.12	100336.65	.20	-4.14
493	044895	HD	01/19/77	300	10	27	1975	6.62	-.01	35.08	164973.26	.28	-8.27
494	044899	HD	12/27/76	301	10	28	1975	6.62	-.00	35.06	182918.85	.21	-9.05
495	044909	HD	01/26/77	302	10	29	1975	6.62	-.01	35.03	262236.09	.26	-2.59
496	045750	HD	08/11/77	303	10	30	1975	6.62	-.06	35.01	163558.63	.19	-2.46
497	044898	HD	12/27/76	304	10	31	1975	6.62	-.02	34.99	8006655.63	.28	-1.58
498	045747	HD	08/11/77	305	11	1	1975	6.62	-.03	34.97	2502080.53	.15	-21.74
499	044906	HD	12/21/76	306	11	2	1975	6.62	-.00	34.95	2293995.65	.33	-13.93
500	044896	HD	12/21/76	307	11	3	1975	6.62	-.00	34.94	6065980.25	.93	-28.50
501	044892	HD	03/11/77	308	11	4	1975	6.62	-.03	34.92	394526.78	.81	-11.57
502	044894	HD	01/07/77	309	11	5	1975	6.62	-.02	34.91	542930.84	.32	-17.63
503	044907	HD	01/07/77	310	11	6	1975	6.62	-.07	34.91	575094.05	.49	-10.25
504	044903	HD	11/07/77	311	11	7	1975	6.62	-.00	35.51	5399716.88	.28	-7.38
505	045749	HD	03/12/77	312	11	8	1975	6.62	-.03	35.55	475923.68	.22	-2.62
506	044901	HD	12/22/76	313	11	9	1975	6.62	-.02	34.91	446419.30	.21	-5.33
507	044904	HD	12/22/76	314	11	10	1975	6.62	-.02	35.65	241696.59	.26	-2.25

-47-

ORIGINAL PAGE IS
POOR QUALITY

REC	AC	TAPE	PROC	DY	MN	DM	YEAR	R	LAT	LOX	E1	P1	BX	
508	044	929	HD	01/15/77	315	11	11	1975	6.62	-01	34.91	473675.36	.23	-14.61
509	044	926	HD	01/26/77	316	11	12	1975	6.62	-02	34.91	424148.78	.20	-14.53
510	044	925	HD	01/15/77	317	11	13	1975	6.62	00	34.92	396740.82	.29	-25.52
511	044	927	HD	01/15/77	318	11	14	1975	6.62	-02	34.92	376180.86	.20	-24.35

INCONSISTENT DAYS

512	044	900	HD	01/17/77	319	11	14	1975	6.62	-02	34.93	285773.13	.32	-22.74
513	044	924	HD	01/17/77	320	11	16	1975	6.62	00	34.92	314016.71	.31	-18.61
514	044	934	HD	01/17/77	321	11	17	1975	6.62	-01	34.95	196116.78	.47	-30.74
515	045	748	HD	03/15/77	322	11	18	1975	6.62	01	34.97	1066902.36	.60	-30.62
516	044	928	HD	01/17/77	323	11	19	1975	6.62	-01	34.96	176683.48	.23	-33.88
517	044	922	HD	01/15/77	324	11	20	1975	6.62	00	35.01	210387.73	.48	-20.23
518	044	948	HD	01/15/77	325	11	21	1975	6.61	-17	35.04	30528.66	.38	-01.00
519	044	935	HD	01/15/77	326	11	22	1975	6.62	00	35.05	472771.81	.41	-34.92
520	044	920	HD	01/15/77	327	11	23	1975	6.62	-02	35.05	429027.14	.46	-33.11
521	044	921	HD	01/24/77	328	11	24	1975	6.62	00	35.10	399221.41	.31	-35.68
522	044	937	HD	01/24/77	329	11	25	1975	6.62	-01	35.00	360505.72	.13	-30.24
523	044	923	HD	01/24/77	330	11	26	1975	6.62	-01	35.15	340831.47	.21	-30.82
524	044	933	HD	01/24/77	331	11	27	1975	6.62	-01	34.96	471944.40	.27	-31.58
525	044	931	HD	01/14/77	332	11	28	1975	6.62	00	34.95	386027.00	.27	-32.48
526	044	942	HD	01/14/77	333	11	29	1975	6.62	00	34.93	115783.52	.18	-30.02
527	044	947	HD	01/14/77	334	11	30	1975	6.62	00	34.92	3292210.53	.24	-30.04
528	044	932	HD	01/14/77	335	12	1	1975	6.62	-01	34.90	5000970.14	.19	-30.17
529	044	938	HD	01/14/77	336	12	2	1975	6.62	-01	35.35	551910.78	.31	-30.53
530	044	940	HD	01/14/77	337	12	3	1975	6.62	01	34.89	564237.07	.24	-30.52
531	044	939	HD	01/14/77	338	12	4	1975	6.62	-01	34.88	478354.18	.25	-30.88
532	044	945	HD	01/14/77	339	12	5	1975	6.62	02	34.88	472225.13	.33	-22.40
533	044	936	HD	01/14/77	340	12	6	1975	6.62	01	34.89	423155.23	.24	-30.89
534	044	943	HD	01/14/77	341	12	7	1975	6.62	01	34.89	209284.44	.28	-17.76
535	044	944	HD	01/14/77	342	12	8	1975	6.62	00	34.89	132952.30	.18	-30.71
536	044	944	HD	01/15/77	343	12	9	1975	6.62	-01	34.90	365237.25	.28	-22.08
537	044	930	HD	01/15/77	344	12	10	1975	6.62	00	34.90	411530.80	.38	-30.96
538	044	946	HD	01/15/77	345	12	11	1975	6.62	-02	34.91	455896.75	.22	-30.94
539	045	030	HD	02/03/77	346	12	12	1975	6.62	00	34.92	225168.89	.26	-30.64
540	045	039	HD	02/03/77	347	12	13	1975	6.62	-06	34.94	210765.02	.27	-30.00
541	045	028	HD	02/03/77	348	12	14	1975	6.62	00	34.95	118763.63	.34	-22.38
542	045	033	HD	02/03/77	349	12	15	1975	6.62	-00	34.96	61824.88	.35	-25.29
543	045	001	HD	02/03/77	350	12	16	1975	6.62	01	34.98	479994.30	.25	-22.71
544	045	031	HD	02/03/77	351	12	17	1975	6.62	00	35.00	303246.36	.22	-11.97
545	045	021	HD	02/03/77	352	12	18	1975	6.62	01	35.02	3031925.43	.18	-11.59
546	045	005	HD	02/03/77	353	12	19	1975	6.62	00	35.05	3239908.59	.23	-11.73
547	045	003	HD	02/03/77	354	12	20	1975	6.62	00	35.10	2804405.53	.29	-22.42
548	045	002	HD	02/03/77	355	12	21	1975	6.62	-01	35.07	222746.90	.17	-12.38
549	045	007	HD	02/03/77	356	12	22	1975	6.62	00	35.03	45177.01	.34	-11.43
550	045	022	HD	02/04/77	357	12	23	1975	6.62	00	35.00	281121.54	.21	-11.94
551	045	018	HD	02/04/77	358	12	24	1975	6.62	00	34.97	305455.96	.18	-22.83
552	045	017	HD	02/04/77	359	12	25	1975	6.62	00	34.94	54691.09	.26	-11.95
553	045	016	HD	02/04/77	360	12	26	1975	6.62	00	34.91	258998.29	.33	-11.32
554	045	011	HD	02/04/77	361	12	27	1975	6.62	00	34.89	420318.62	.14	-12.87
555	045	009	HD	02/04/77	362	12	28	1975	6.62	00	34.87	583122.28	.31	-10.47

REC	AC TAPE	PROC	CY	MN	DM	YEAR	R	LAT	LON	E1	P1	BX	
5556	045008	HO	(2/03/77	363	12	29	1975	0.62	.00	34.85	322439.43	.84	-29.72
5557	045034	HO	02/03/77	364	12	30	1975	0.62	.00	34.83	487553.31	.60	-25.37
5558	045036	HO	02/03/77	365	12	31	1975	0.62	.00	34.81	442759.96	.36	-26.44
5559	045024	HO	02/03/77	1	1	1	1976	0.62	-.00	34.80	418680.60	.46	14.30
5600	045025	HO	02/03/77	2	1	2	1976	0.62	.01	34.79	298882.74	.37	13.85
5601	045010	HO	02/03/77	3	1	3	1976	0.62	.00	34.78	179213.27	.20	17.27
1 DAYS MISSING													
562	045038	HO	(2/03/77	5	1	5	1976	0.62	-.01	34.76	194990.98	.32	33.93
563	045006	HO	02/03/77	7	1	7	1976	0.62	-.00	34.76	331981.88	.23	20.89
564	045026	HO	02/03/77	8	1	8	1976	0.62	-.03	34.75	309757.52	.22	25.13
565	045032	HO	02/03/77	9	1	9	1976	0.62	-.00	34.75	427000.04	.24	16.95
566	045020	HO	02/04/77	9	1	9	1976	0.62	-.03	34.75	303610.87	.11	13.92
567	045029	HO	02/04/77	10	1	10	1976	0.62	.01	34.75	231903.42	.31	20.33
568	045012	HO	02/04/77	11	1	11	1976	0.62	-.00	34.76	23931.78	.57	109.23
569	045023	HO	02/04/77	12	1	12	1976	0.62	.00	34.76	565507.23	.28	32.09
570	045004	HO	02/03/77	13	1	13	1976	0.62	.00	34.77	402796.01	.24	25.59
571	044908	HO	02/03/77	14	1	14	1976	0.62	-.00	34.78	364691.80	.22	21.17
572	045589	HO	06/15/77	15	1	15	1976	0.62	.02	219.97	247428.29	.20	20.33
573	045027	HO	(2/03/77	16	1	16	1976	0.62	-.00	34.80	156379.67	.25	24.06
1 DAYS MISSING													
574	045013	HO	02/04/77	18	1	18	1976	0.62	-.00	34.83	111559.81	.18	48.64
575	045014	HO	(2/04/77	19	1	19	1976	0.62	.00	34.83	373030.88	.26	25.35
576	045015	HO	(2/04/77	20	1	20	1976	0.62	-.00	34.84	71087.48	.21	34.85
577	045037	HO	02/04/77	21	1	21	1976	0.62	.00	34.84	63111.00	.32	19.31
578	045071	HO	02/12/77	22	1	22	1976	0.62	.01	34.85	362615.70	.26	20.27
579	045051	HO	02/12/77	23	1	23	1976	0.62	-.00	34.86	270732.82	.38	28.97
580	045059	HO	02/12/77	24	1	24	1976	0.62	.01	34.88	498723.26	.38	18.46
581	045063	HO	(2/12/77	25	1	25	1976	0.62	.00	34.89	476980.68	.21	16.21
582	045060	HO	02/13/77	26	1	26	1976	0.62	.05	34.90	475848.50	.31	14.66
583	045086	HO	02/18/77	27	1	27	1976	0.62	.00	34.93	379384.24	.20	13.56
584	045052	HO	02/18/77	28	1	28	1976	0.62	.00	34.95	322321.36	.17	6.98
585	045083	HO	(2/18/77	29	1	29	1976	0.62	.00	34.97	53692.49	.20	13.18
586	045093	HO	02/11/77	30	1	30	1976	0.62	-.00	35.00	178849.80	.21	10.83
587	045076	HO	02/11/77	31	1	31	1976	0.62	.00	34.97	234518.27	.24	26.70
588	045065	HO	02/11/77	2	2	2	1976	0.62	.01	34.96	335098.06	.20	32.90
589	045064	HO	02/11/77	3	2	3	1976	0.62	.01	34.96	450111.37	.25	29.27
590	045055	HO	02/11/77	4	2	4	1976	0.62	.01	34.95	378828.04	.18	22.90
591	045089	HO	02/11/77	5	2	5	1976	0.62	.00	34.94	477048.84	.21	22.12
592	045066	HO	02/11/77	6	2	6	1976	0.62	.01	34.94	423788.39	.17	12.44
593	045087	HO	02/11/77	7	2	7	1976	0.62	.01	34.94	487046.94	.19	16.72
594	045067	HO	02/12/77	8	2	8	1976	0.62	.01	34.94	352341.49	.13	15.34
595	045054	HO	(2/12/77	9	2	9	1976	0.62	-.00	34.94	225813.25	.17	34.37
596	045093	HO	(2/25/77	10	2	10	1976	0.62	.01	34.95	532521.83	.22	19.87
597	045075	HO	02/12/77	11	2	11	1976	0.62	.00	34.96	565220.79	.20	10.72
598	045050	HO	02/11/77	12	2	12	1976	0.62	.01	34.97	482901.75	.23	11.18
599	045073	HO	02/11/77	13	2	13	1976	0.62	.01	34.98	418679.84	.23	13.16
600	045073	HO	02/11/77	14	2	14	1976	0.62	.01	34.98	515085.02	.35	18.60

ORIGINAL PAGE IS
OF POOR QUALITY

REC	AC	TAPE	PROC	DY	MN	DM	YEAR	R	LAT	LOX	E1	P1	BX
601	045081	HO	02/11/77	45	2	14	1976	0.02	.01	35.00	513213.23	.18	12.09
602	045083	HO	02/11/77	46	2	15	1976	0.02	.02	35.01	437643.83	.345	19.22
603	045058	HO	02/11/77	47	2	16	1976	0.02	.00	35.03	461410.79	.233	2.60
604	045091	HO	02/11/77	48	2	17	1976	0.02	.04	35.04	319509.40	.54	5.17
605	045062	HO	02/11/77	49	2	18	1976	0.02	.00	35.06	92213.16	.54	18.22
606	045092	HO	02/11/77	50	2	19	1976	0.02	.00	35.08	407203.33	2.11	9.45
607	045068	HO	02/11/77	51	2	20	1976	0.02	.00	35.11	456299.24	1.33	14.27
1 DAYS MISSING													
608	045056	HO	02/11/77	53	2	22	1976	0.02	.00	35.09	357736.77	.49	16.90
609	045061	HO	02/11/77	54	2	23	1976	0.02	.00	35.06	446520.03	.56	4.21
610	045057	HO	02/12/77	55	2	24	1976	0.02	.00	35.04	394932.38	.34	1.45
611	045090	HO	02/12/77	56	2	25	1976	0.02	.02	35.02	274759.69	.51	7.94
612	045088	HO	02/12/77	57	2	26	1976	0.02	.00	35.00	148994.53	.55	1.32
613	045084	HO	02/12/77	58	2	27	1976	0.02	.00	34.99	30601.57	.34	31.49
614	045069	HO	02/12/77	59	2	28	1976	0.02	.00	34.97	498442.36	.24	16.77
615	045078	HO	02/12/77	60	2	29	1976	0.02	.04	34.95	240053.13	.22	16.40
616	045074	HO	02/12/77	61	2	1	1976	0.02	.13	34.93	48140.52	.22	12.75
617	045077	HO	02/12/77	62	2	2	1976	0.02	.14	34.93	-1.00	-1.	-1.00
618	045082	HO	02/11/77	63	2	3	1976	0.02	.00	34.93	558449.80	.34	6.15
619	045072	HO	02/11/77	64	2	4	1976	0.02	.00	34.92	524019.35	.22	13.92
620	045079	HO	02/11/77	65	2	5	1976	0.02	.00	34.92	465889.95	.22	4.73
621	045125	HO	02/26/77	66	2	6	1976	0.02	.00	34.91	4832262.56	.22	9.99
622	045134	HO	02/26/77	67	2	7	1976	0.02	.00	34.93	513282.21	.22	16.31
623	045128	HO	02/26/77	68	2	8	1976	0.02	.00	34.93	503424.30	.22	21.89
624	045133	HO	03/01/77	69	2	9	1976	0.02	.00	34.94	532065.56	.22	-23.01
625	045135	HO	02/26/77	70	2	10	1976	0.02	.01	34.94	528230.32	.22	16.85
626	045151	HO	02/26/77	71	2	11	1976	0.02	.00	34.95	51586.59	.22	12.50
627	045136	HO	02/25/77	72	2	12	1976	0.02	.00	34.96	51586.59	.22	30.21
628	045157	HO	02/25/77	73	2	13	1976	0.02	.00	34.97	509673.90	.22	8.20
629	045131	HO	02/25/77	74	2	14	1976	0.02	.00	34.98	51495.93	.22	11.96
630	045132	HO	02/25/77	75	2	15	1976	0.02	.00	34.99	555008.94	.22	3.72
631	045143	HO	02/26/77	76	2	16	1976	0.02	.02	35.00	16456.01	.22	4.52
632	045146	HO	02/26/77	77	2	17	1976	0.02	.01	35.02	381037.62	.22	8.33
633	045141	HO	02/26/77	78	2	18	1976	0.02	.01	35.03	528829.73	.22	4.72
634	045145	HO	03/13/77	79	2	19	1976	0.02	.00	35.06	421125.05	.22	-22.42
1 DAYS MISSING													
635	045144	HO	02/25/77	81	2	21	1976	0.02	.00	35.08	403014.09	.28	.99
636	045140	HO	02/25/77	82	2	22	1976	0.02	.00	35.05	341683.35	.27	-1.20
637	045137	HO	02/25/77	83	2	23	1976	0.02	.01	35.03	267362.60	.24	-2.86
638	045139	HO	02/26/77	84	2	24	1976	0.02	.00	35.01	250852.30	.10	-2.04
639	045155	HO	02/26/77	85	2	25	1976	0.02	.00	34.99	232705.97	.36	-3.37
640	045174	HO	02/26/77	86	2	26	1976	0.02	.01	34.97	97911.14	.40	-5.30
641	045129	HO	05/08/77	87	2	27	1976	0.02	.00	34.95	308429.58	.67	-11.11
642	045138	HO	02/25/77	88	2	28	1976	0.02	.00	34.94	613923.92	.53	8.00
643	045166	HO	02/25/77	89	2	29	1976	0.02	.01	34.92	430083.60	.62	4.40
644	045130	HO	02/25/77	90	2	30	1976	0.02	.00	34.91	412563.28	.62	4.74
645	045152	HO	02/25/77	91	2	31	1976	0.02	.02	34.90	519034.51	.59	7.89

REC	AC TAPE	PROC	DY	MN	DM	YEAR	R	LAT	LON	E1	P1	BX	
646	045147	HD	02/25/77	92	4	1	1976	6.62	.00	34.89	426272.44	.67	-.48
647	045158	HD	02/23/77	93	4	2	1976	6.62	.01	34.88	522502.10	.22	17.38
648	045171	HD	02/25/77	95	4	3	1976	6.62	.00	34.88	425401.06	.27	19.13
649	045142	HD	02/25/77	95	4	4	1976	6.62	.00	34.88	516058.17	.22	15.28
650	045149	HD	02/26/77	97	4	5	1976	6.62	.00	34.88	556744.20	.38	13.21
651	045156	HD	02/26/77	97	4	6	1976	6.62	-.00	34.88	585993.56	3.3	5.42
652	045172	HD	02/26/77	98	4	7	1976	6.62	-.00	34.88	618236.78	2.54	5.07
653	045150	HD	02/26/77	99	4	8	1976	6.62	.00	34.89	672743.25	2.21	2.22
654	045159	HD	02/26/77	100	4	9	1976	6.62	.00	34.89	433518.08	3.5	4.22
655	045161	HD	02/26/77	101	4	10	1976	6.62	.00	34.90	317792.05	.31	7.78
656	045148	HD	02/26/77	102	4	11	1976	6.62	-.00	34.91	277205.60	.31	-5.98
657	045170	HD	02/26/77	103	4	12	1976	6.62	.00	34.92	141941.97	.46	-1.28
658	045160	HD	02/26/77	104	4	13	1976	6.62	-.00	34.93	341212.45	.39	-1.00
659	045169	HD	02/26/77	105	4	14	1976	6.62	-.00	34.94	340052.64	.20	-4.57
660	045177	HD	02/26/77	106	4	15	1976	6.62	-.00	34.95	463983.68	.27	-4.16
661	045154	HD	02/26/77	107	4	16	1976	6.62	.00	34.97	424851.65	.20	-5.75
662	045175	HD	02/23/77	108	4	17	1976	6.62	.00	34.99	355455.11	.22	-26.11

1 DAYS MISSING

663	045153	HD	02/28/77	110	4	19	1976	6.62	-.00	34.96	184580.79	.15	-24.43
664	045173	HD	02/28/77	111	4	20	1976	6.62	-.00	34.94	246347.02	.31	-22.72
665	045167	HD	02/28/77	112	4	21	1976	6.62	.02	34.92	138920.94	.20	-22.23
666	045164	HD	02/28/77	113	4	22	1976	6.62	.00	34.91	30307.88	.30	-22.02
667	045168	HD	02/28/77	114	4	23	1976	6.62	.01	34.89	455529.55	.27	-17.06
668	045165	HD	02/28/77	115	4	24	1976	6.62	.00	34.88	173097.27	.27	-22.60
669	045176	HC	02/28/77	116	4	25	1976	6.62	.00	34.87	325573.18	.25	-16.89
670	045162	HD	03/18/77	117	4	4	1976	6.62	.00	34.86	404231.51	.31	-19.10
671	045153	HD	02/28/77	118	4	27	1976	6.62	-.00	34.85	204244.61	.25	-4.73
672	045178	HD	02/28/77	119	4	28	1976	6.62	.00	34.85	319089.30	.50	-7.97
673	045191	HD	03/09/77	120	4	9	1976	6.62	.01	34.85	332748.63	.40	-21.40
674	044786	HD	03/03/77	121	4	30	1976	6.62	-.00	34.85	233161.04	.20	-12.72
675	044793	HD	10/15/76	122	5	1	1976	6.62	-.04	34.86	482901.16	17.0	8.66
676	044792	HD	10/18/76	123	5	2	1976	6.62	-.00	-1.00	182301.08	7.2	3.39
677	044459	HD	10/13/76	124	5	3	1976	6.62	-.00	-1.00	177812.81	3.34	-1.00

INCONSISTENT DAYS

678	044788	HD	10/15/76	125	5	4	1976	6.62	-.00	34.88	412048.79	.42	3.26
679	044791	HD	10/18/76	126	5	5	1976	6.62	.00	34.89	513268.71	.73	.46
680	044790	HD	10/13/76	127	5	6	1976	6.62	.00	34.90	476581.23	.40	1.78
681	045208	HD	03/03/77	128	5	7	1976	6.62	.00	34.92	577740.99	.79	-14.22
682	045194	HD	04/07/77	129	5	8	1976	6.62	.00	34.93	555315.27	.99	-21.72
683	045190	HD	03/03/77	130	5	9	1976	6.62	.00	34.94	158014.16	.21	-20.51
684	045193	HD	03/03/77	131	5	10	1976	6.62	.00	34.96	288865.64	.31	-22.52
685	045189	HD	03/03/77	132	5	11	1976	6.62	-.00	34.98	290281.95	.35	-23.25
686	045239	HD	03/09/77	133	5	12	1976	6.62	-.00	35.00	636399.14	.32	-18.82
687	045207	HD	03/09/77	134	5	13	1976	6.62	-.00	35.02	348863.29	.29	-22.19
688	045198	HD	03/03/77	135	5	14	1976	6.62	-.00	35.05	255102.24	.31	-21.89
689	045231	HD	03/09/77	136	5	15	1976	6.62	-.00	35.05	256648.85	.18	-23.73
690	045192	HD	03/03/77	137	5	16	1976	6.62	-.00	35.03	314479.52	.38	-22.37

REC	AC	TAPE	PPOC	GY	MN	DM	YEAR	F	LAT	LON	E1	P1	BX	
691	045	195	HD	03/09/77	138	5	17	1976	5.62	- .00	35.01	144826.47	.22	-22.55
692	045	199	HD	03/09/77	139	5	18	1976	5.62	- .00	34.99	128952.82	63.15	-22.96
693	045	200	HD	03/09/77	140	5	19	1976	5.62	- .00	34.98	93076.30	.45	-24.66
694	045	217	HD	03/09/77	141	5	20	1976	5.62	- .00	34.98	16717.94	.34	-28.83
695	045	197	HD	03/11/77	142	5	21	1976	5.62	- .00	34.95	456678.65	.25	-19.26
696	045	230	HD	03/10/77	143	5	22	1976	5.62	- .02	34.93	148010.37	.27	-19.68
697	045	216	HD	03/11/77	144	5	23	1976	5.62	- .00	34.93	418534.51	.17	-20.69
698	045	196	HD	03/10/77	145	5	24	1976	5.62	- .00	34.92	309565.61	.38	-18.53
699	045	205	HD	04/07/77	146	5	25	1976	5.62	- .00	34.91	177081.65	.31	-21.56
700	045	206	HD	03/10/77	147	5	26	1976	5.62	- .00	34.91	278221.74	.17	-17.91

1 DAYS MISSING

701	045	220	HD	03/10/77	149	5	28	1976	5.62	- .00	34.91	453571.81	.22	-17.77
702	045	204	HD	03/10/77	150	5	29	1976	5.62	- .00	34.91	642892.33	1.00	-16.32
703	045	209	HD	03/10/77	151	5	30	1976	5.62	- .03	34.93	531864.21	.33	-19.86
704	045	237	HD	03/10/77	152	5	31	1976	5.62	- .00	34.94	489939.46	.29	-16.86
705	045	202	HD	03/10/77	153	5	1	1976	5.62	- .00	34.95	416101.08	.22	-17.90
706	045	218	HD	03/09/77	154	5	2	1976	5.62	- .00	34.96	525717.41	.27	-18.23
707	045	201	HD	03/09/77	155	5	3	1976	5.62	- .00	34.96	363543.53	.33	-17.31
708	045	214	HD	03/09/77	156	5	4	1976	5.62	- .00	34.98	155546.91	.24	-16.10
709	045	289	HD	03/13/77	157	5	5	1976	5.62	- .02	34.99	358384.26	.29	-24.49

1 DAYS MISSING

710	045	203	HD	03/10/77	159	5	7	1976	5.61	- .10	34.98	429843.16	.30	-20.79
711	045	212	HD	03/10/77	160	5	8	1976	5.62	- .00	35.05	524550.75	.17	-23.05
712	045	238	HD	03/10/77	161	5	9	1976	5.61	- .08	35.02	444178.30	.32	-20.61
713	045	221	HD	03/10/77	162	5	10	1976	5.62	- .00	35.09	420222.18	.20	-21.53
714	045	219	HD	03/13/77	163	5	11	1976	5.62	- .00	35.12	371133.29	.20	-15.56
715	045	215	HD	03/13/77	164	5	12	1976	5.62	- .00	35.14	322439.69	.23	-17.66
716	045	241	HD	03/13/77	165	5	13	1976	5.62	- .00	35.16	388289.19	.25	-21.42
717	045	210	HD	03/13/77	166	5	14	1976	5.62	- .00	35.13	377643.63	.23	-18.97
718	045	188	HD	03/13/77	167	5	15	1976	5.62	- .00	35.11	327103.86	.35	-19.85
719	045	227	HD	03/13/77	168	5	16	1976	5.62	- .00	35.08	182730.98	.30	-19.97
720	045	240	HD	03/13/77	169	5	17	1976	5.62	- .00	35.06	136549.29	.30	-17.75
721	045	222	HD	03/13/77	170	5	18	1976	5.62	- .00	35.04	281002.47	.32	-17.71
722	045	223	HD	03/13/77	171	5	19	1976	5.62	- .00	35.02	439321.04	.20	-17.79
723	045	211	HD	03/13/77	172	5	20	1976	5.62	- .00	35.01	421846.25	.23	-20.13
724	045	243	HD	03/19/77	173	5	21	1976	5.62	- .00	34.99	330807.46	.27	-19.30
725	045	228	HD	03/13/77	174	5	22	1976	5.62	- .00	34.98	225178.17	.23	-20.06
726	045	233	HD	03/13/77	175	5	23	1976	5.62	- .00	34.97	152194.85	.27	-20.56
727	045	224	HD	03/13/77	176	5	24	1976	5.62	- .00	34.96	108435.32	.24	-19.41
728	045	225	HD	03/13/77	177	5	25	1976	5.62	- .00	34.96	36110.62	.18	-15.36
729	045	234	HD	03/13/77	178	5	26	1976	5.62	- .00	34.95	427919.70	.24	-16.64
730	045	229	HD	03/13/77	179	5	27	1976	5.62	- .00	34.95	3327862.18	.31	-17.28
731	045	232	HD	03/13/77	180	5	28	1976	5.62	- .00	34.95	462752.21	.22	-17.78
732	045	239	HD	03/13/77	181	5	29	1976	5.62	- .00	34.95	302556.84	.21	-16.83
733	045	226	HD	03/19/77	182	5	30	1976	5.62	- .00	34.96	257462.13	.34	-21.53

1 DAYS MISSING

REC	AC	TAPE	PROC	DY	MN	DM	YEAR	R	LAT	LON	E1	P1	BX	
734	045	327	HD	03/26/77	184	7	2	1976	6.62	-.00	34.96	522691.14	.32	-28.41
735	045	295	HD	04/07/77	185	7	3	1976	6.62	-.00	34.97	484037.05	.42	-22.18
736	045	297	HD	03/26/77	186	7	4	1976	6.62	-.00	34.98	488229.33	.42	-20.09
1 DAYS MISSING														
737	045	309	HD	03/26/77	188	7	6	1976	6.62	-.03	34.99	436502.05	.31	-21.36
738	045	319	HD	03/26/77	189	7	7	1976	6.61	-.03	34.98	422667.53	.31	-21.18
739	045	298	HD	03/26/77	190	7	8	1976	6.62	-.00	35.03	477468.73	.20	-22.72
740	045	308	HD	03/26/77	191	7	9	1976	6.62	-.00	35.05	478372.39	.22	-27.58
741	045	290	HD	03/26/77	192	7	10	1976	6.62	-.00	35.07	447433.60	.28	-22.63
742	045	296	HD	03/26/77	193	7	11	1976	6.62	.00	35.09	364942.87	.71	-22.85
1 DAYS MISSING														
743	044	704	HD	03/26/77	195	7	13	1976	6.62	-.00	35.03	181374.56	.24	-22.69
744	045	300	HD	03/25/77	196	7	14	1976	6.62	-.00	35.01	145008.06	.27	-24.39
745	045	320	HD	04/08/77	197	7	15	1976	6.62	-.00	35.00	203869.09	.21	-18.46
746	045	323	HD	04/08/77	198	7	16	1976	6.62	-.00	34.98	193901.20	.29	-20.09
747	045	293	HD	04/08/77	199	7	17	1976	6.62	-.00	34.97	481878.64	.24	-19.68
748	045	303	HD	04/07/77	200	7	18	1976	6.62	-.06	34.94	437884.97	.17	-22.27
749	045	299	HD	03/26/77	201	7	19	1976	6.62	-.00	34.94	474990.48	.38	-21.58
750	045	301	HD	04/07/77	202	7	20	1976	6.62	-.00	34.94	355632.74	.22	-23.09
751	045	342	HD	04/08/77	203	7	21	1976	6.62	-.00	34.93	248956.22	.31	-20.51
752	045	341	HD	03/26/77	204	7	22	1976	6.62	-.00	34.93	188323.91	.30	-23.43
753	045	302	HD	03/26/77	205	7	23	1976	6.62	-.00	34.93	87079.30	.25	-20.27
1 DAYS MISSING														
754	045	306	HD	03/26/77	207	7	25	1976	6.62	-.00	34.94	155187.30	.18	-19.21
1 DAYS MISSING														
755	044	705	HD	04/08/77	209	7	27	1976	6.62	-.00	34.94	165637.97	.24	-20.13
756	045	322	HD	04/15/77	210	7	28	1976	6.62	-.00	34.95	142184.21	.20	-30.98
757	045	333	HD	04/15/77	211	7	29	1976	6.62	-.01	34.96	385462.30	.31	-25.56
758	045	328	HD	03/26/77	212	7	30	1976	6.62	-.00	34.97	462344.97	.18	-20.97
759	045	316	HD	03/26/77	213	7	31	1976	6.62	-.02	34.98	525847.32	.34	-1.00
760	045	349	HD	04/15/77	214	8	1	1976	6.62	-.01	34.99	407226.55	.24	-20.55
761	045	326	HD	04/15/77	215	8	2	1976	6.62	-.00	35.00	377880.88	.22	-19.86
762	045	350	HD	03/26/77	216	8	3	1976	6.63	-.00	34.52	422688.83	.18	-23.67
763	045	313	HD	04/08/77	217	8	4	1976	6.63	-.00	33.63	384064.37	.21	-19.28
764	045	330	HD	03/26/77	218	8	5	1976	6.63	-.00	32.16	286241.59	.23	-19.86
1 DAYS MISSING														
765	045	339	HD	03/26/77	220	8	7	1976	6.63	-.00	29.21	375652.07	.19	-22.97
766	045	352	HD	04/08/77	221	8	8	1976	6.63	-.00	27.74	319130.91	.25	-20.37
767	045	351	HD	03/26/77	222	8	9	1976	6.63	-.00	26.25	130298.71	.31	-20.98
768	045	340	HD	04/09/77	223	8	10	1976	6.63	-.00	24.79	283788.28	.31	-24.67
769	045	332	HD	04/06/77	224	8	11	1976	6.63	-.00	23.33	413726.55	.28	-24.08

REC	AC TAPE	PROC	DY	MN	DM	YEAR	R	LAT	LOX	E1	P1	8X
770	045331 HD	04/06/77	225	8	12	1976	5.63	.00	21.86	457855.80	.36	-22.36
	1 DAYS MISSING											
771	045324 HD	04/06/77	227	8	14	1976	5.63	-.02	18.99	251714.49	.17	-19.80
772	045343 HD	04/06/77	228	8	15	1976	5.63	-.00	17.48	162460.84	.32	-22.85
773	045347 HD	04/06/77	229	8	16	1976	5.63	-.00	16.02	214524.85	.27	-20.62
	1 DAYS MISSING											
774	045345 HD	04/07/77	231	8	18	1976	5.63	-.00	13.11	101856.90	.20	-18.96
	1 DAYS MISSING											
775	045317 HD	04/06/77	233	8	20	1976	5.63	.00	10.22	60831.81	.30	-21.40
776	045312 HD	04/06/77	234	8	21	1976	5.63	-.00	8.78	93643.81	.30	-21.33
777	045344 HD	04/06/77	235	8	22	1976	5.63	-.00	7.34	66452.10	.23	-23.41
778	045334 HD	04/07/77	236	8	23	1976	5.63	-.00	5.90	143823.02	37.82	-20.72
779	045335 HD	04/07/77	237	8	24	1976	5.63	-.00	4.45	392318.70	2.98	-21.86
	INCONSISTENT DAYS											
780	045336 HD	04/07/77	238	8	26	1976	5.63	-.00	3.00	366874.39	.39	-21.38
781	045346 HD	04/07/77	239	8	26	1976	5.63	-.00	1.56	413368.37	.23	-20.43
	1 DAYS MISSING											
782	045348 HD	04/07/77	241	8	28	1976	5.63	-.00	35.66	420722.10	.24	-20.65
783	044884 HD	04/07/77	242	8	29	1976	5.63	-.00	35.22	468183.77	.25	-20.12
784	044886 HD	04/07/77	243	8	30	1976	5.63	-.00	35.78	414476.77	.43	-19.28
785	044885 HD	04/07/77	244	8	31	1976	5.63	-.00	35.34	395820.85	.31	-20.18
786	045310 HD	04/07/77	245	9	1	1976	5.63	-.00	35.90	1092226.33	.23	-24.35
787	045377 HD	04/30/77	246	9	2	1976	5.63	-.01	35.46	203960.74	.20	-15.60
788	045378 HD	04/30/77	247	9	3	1976	5.63	.00	35.01	251976.02	.28	-21.06
789	045318 HD	04/07/77	248	9	4	1976	5.63	-.00	34.58	414946.66	.32	-16.72
790	045392 HD	05/04/77	249	9	5	1976	5.63	-.00	34.13	306606.55	.28	-25.40
791	045379 HD	05/04/77	250	9	6	1976	5.63	-.00	34.70	302976.12	.41	-17.40
792	045380 HD	04/05/77	251	9	7	1976	5.63	-.00	34.27	275228.57	.29	-18.32
793	045382 HD	04/05/77	252	9	8	1976	5.63	-.00	34.83	319318.20	.34	-20.45
794	045432 HD	04/05/77	253	9	9	1976	5.63	-.07	34.52	255156.10	.21	-17.74
795	045389 HD	04/05/77	254	9	10	1976	5.63	-.00	33.96	339589.01	.31	-19.78
796	045381 HD	04/23/77	255	9	11	1976	5.63	-.00	33.52	220846.32	.34	-18.65
797	045390 HD	04/23/77	256	9	12	1976	5.63	-.00	33.09	78968.48	.25	-17.83
798	045398 HD	04/23/77	257	9	13	1976	5.63	-.00	33.65	188285.35	.22	-14.47
799	045434 HD	04/23/77	258	9	14	1976	5.63	-.00	33.21	175885.14	.27	-15.50
800	045411 HD	05/04/77	259	9	15	1976	5.63	-.00	33.77	52240.41	.24	-15.68
801	045412 HD	05/04/77	260	9	16	1976	5.63	-.01	33.37	166557.32	.27	-17.22
802	045391 HD	05/04/77	261	9	17	1976	5.63	-.00	32.89	83534.00	.26	-17.59
803	045384 HD	05/04/77	262	9	18	1976	5.63	.00	32.44	178914.21	.27	-17.51
804	045388 HD	05/04/77	263	9	19	1976	5.63	-.00	32.00	253255.57	.19	-15.80
805	045385 HD	05/04/77	264	9	20	1976	5.63	-.00	32.56	336891.76	.43	-13.36

REC	AC	TAPE	PROC	UY	MN	DM	YEAR	R	LAT	LOX	E1	P1	BX	
806	045	383	HD	05/04/77	265	9	21	1976	6.63	-.00	324.11	472747.58	.21	-13.98
807	045	386	HD	05/04/77	266	9	22	1976	6.63	-.00	322.66	439430.60	.27	-14.58
808	045	425	HD	04/05/77	267	9	23	1976	6.63	-.00	321.21	422946.42	.31	-18.02
809	045	414	HD	04/05/77	268	9	24	1976	6.63	-.00	319.76	425492.02	.27	-18.25
810	045	410	HD	04/05/77	269	9	25	1976	6.63	-.00	318.30	230005.99	.21	-4.26
811	045	387	HD	04/30/77	270	9	26	1976	6.63	-.00	316.85	188344.34	.21	-11.54
1 DAYS MISSING														
812	045	315	HD	04/06/77	272	9	28	1976	6.63	-.00	313.94	270018.23	.18	-20.25
813	045	394	HD	04/30/77	273	9	29	1976	6.63	-.00	312.49	246504.01	.39	-21.81
814	045	413	HD	04/30/77	274	9	30	1976	6.63	-.00	310.99	182060.14	.32	-19.24
815	045	397	HD	04/05/77	275	10	1	1976	6.63	-.00	309.55	141371.25	.28	-11.03
816	045	395	HD	04/05/77	276	10	2	1976	6.63	-.04	308.13	353005.66	.29	-14.10
817	045	393	HD	04/05/77	277	10	3	1976	6.63	-.00	306.62	405158.75	.32	-13.61
INCONSISTENT DAYS														
818	045	406	HD	04/05/77	278	10	5	1976	6.63	-.00	305.16	393695.38	.27	-4.85
819	045	409	HD	04/05/77	279	10	6	1976	6.63	-.01	303.81	247903.41	.35	-12.24
820	045	396	HD	05/04/77	280	10	7	1976	6.63	-.00	302.23	259479.40	.38	-10.64
821	045	399	HD	05/04/77	281	10	8	1976	6.63	-.00	300.76	270507.70	.39	-17.25
822	045	401	HD	05/04/77	282	10	8	1976	6.63	-.00	299.29	298614.40	.31	-15.40
823	045	407	HD	04/30/77	283	10	9	1976	6.63	-.00	297.82	226037.05	.29	-8.76
824	045	402	HD	04/30/77	284	10	10	1976	6.63	-.00	296.35	-1.00	-1.00	-1.00
825	045	403	HD	04/30/77	285	10	11	1976	6.63	-.00	294.87	86154.30	.27	-2.81
826	045	404	HD	04/30/77	286	10	12	1976	6.63	-.00	293.40	58264.17	.25	-13.62
827	045	405	HD	04/05/77	287	10	13	1976	6.63	-.00	291.92	344174.36	.25	-5.25
828	045	330	HD	05/13/77	288	10	14	1976	6.63	-.00	290.45	303174.11	.18	-4.85
829	045	438	HD	04/05/77	289	10	15	1976	6.63	-.00	288.97	65738.54	.17	-7.95
830	045	408	HD	04/05/77	290	10	16	1976	6.63	-.00	287.49	377559.59	.31	-1.45
831	045	427	HD	04/05/77	291	10	17	1976	6.63	-.00	286.00	-1.00	-1.00	-1.00
832	045	416	HD	05/18/77	292	10	18	1976	6.63	-.00	284.54	396352.28	.38	-7.24
833	045	420	HD	05/18/77	293	10	19	1976	6.63	-.00	283.05	458534.26	.23	-4.97
834	045	431	HD	04/05/77	294	10	20	1976	6.63	-.00	281.56	321805.55	.17	-4.63
835	045	426	HD	05/18/77	295	10	21	1976	6.63	.01	280.05	374017.24	.32	-4.50
836	045	421	HD	05/18/77	296	10	22	1976	6.63	-.00	278.58	84384.39	.27	-1.27
837	045	415	HD	05/05/77	297	10	23	1976	6.63	-.00	277.10	106864.08	.14	1.49
INCONSISTENT DAYS														
838	045	433	HD	05/05/77	298	10	23	1976	6.63	-.01	275.58	-1.00	-1.00	-1.00
839	045	435	HD	05/05/77	299	10	25	1976	6.63	-.00	274.11	187758.63	.27	3.65
INCONSISTENT DAYS														
840	045	430	HD	05/05/77	300	10	25	1976	6.63	-.00	272.62	110084.22	.24	3.36
841	045	422	HD	05/05/77	301	10	27	1976	6.63	-.00	271.13	87971.76	.21	5.45
842	045	436	HD	05/05/77	302	10	28	1976	6.63	-.00	269.64	187661.74	.32	3.78
843	045	424	HD	05/05/77	303	10	29	1976	6.63	-.00	268.15	50123.41	.30	6.44
844	045	428	HD	05/05/77	304	10	30	1976	6.63	-.00	266.65	76204.55	.27	6.72

-55-

ORIGINAL PAGE IS
OF POOR QUALITY

REC	AC TAPE	PROC	DY	MN	DM	YEAR	P	LAT	Lon	E1	P1	BX	
845	045423	HD	05/05/77	305	10	31	1976	6.63	.00	265.14	327831.56	.64	-5.38
846	045417	HD	05/05/77	306	11	1	1976	5.63	.01	263.65	383972.85	.31	2.02
1 DAYS MISSING													
847	045439	HD	05/24/77	308	11	3	1976	6.63	.02	260.66	305191.57	.29	5.34
848	045437	HD	05/05/77	309	11		1976	6.63	.01	259.16	341290.61	.29	9.90
849	045466	HD	05/18/77	310	11		1976	6.63	.01	259.67	284218.07	.25	9.76
850	045507	HD	05/18/77	311	11		1976	6.63	-.00	256.20	252098.78	.37	11.98
851	045533	HD	05/18/77	312	11		1976	6.63	.01	254.67	194310.92	.27	13.15
852	045474	HD	05/13/77	313	11		1976	6.63	.01	253.16	129565.31	.40	10.60
853	045467	HD	05/13/77	314	11		1976	6.63	.01	251.67	49440.99	.32	12.74
854	045499	HD	05/18/77	315	11	10	1976	6.63	.00	250.20	129387.37	.25	10.91
855	045472	HD	05/18/77	316	11	11	1976	6.63	.01	248.69	436457.77	.38	12.48
856	045487	HD	05/18/77	317	11	12	1976	6.63	.01	247.22	420526.64	.27	10.20
857	045568	HD	06/14/77	318	11	13	1976	6.63	.01	245.70	402286.19	.29	11.76
1 DAYS MISSING													
858	045583	HD	06/14/77	320	11	15	1976	6.63	.01	242.71	513052.59	.28	12.24
859	045469	HD	05/13/77	321	11	16	1976	6.63	.01	241.20	490939.09	.38	13.50
860	044919	HD	05/18/77	322	11	17	1976	6.63	-.08	239.87	301070.08	.38	15.60
861	045475	HD	05/13/77	323	11	18	1976	6.63	-.01	238.21	282834.21	.38	-23.15
862	045476	HD	05/18/77	324	11	19	1976	6.63	-.09	236.90	254301.64	.22	-20.98
863	045477	HD	05/13/77	325	11	20	1976	6.63	-.00	235.26	151755.87	.35	-28.02
864	045473	HD	05/18/77	326	11	21	1976	6.63	-.17	234.19	177099.91	.17	-24.77
865	045468	HD	05/13/77	327	11	22	1976	6.63	-.00	232.28	191011.16	.24	-32.61
1 DAYS MISSING													
866	045485	HD	05/18/77	329	11	24	1976	6.63	-.00	229.29	67163.47	.24	-31.22
2 DAYS MISSING													
867	045498	HD	05/17/77	332	11	27	1976	6.63	.00	224.83	159860.36	.26	-28.69
868	045471	HD	05/17/77	333	11	28	1976	6.63	-.00	223.36	337594.02	.20	-21.59
869	045480	HD	05/13/77	334	11	29	1976	6.63	-.00	221.86	294828.65	.24	-26.39
870	045489	HD	05/13/77	335	11	30	1976	6.63	-.00	220.91	251147.38	.28	-27.74
871	045482	HD	05/13/77	336	12	1	1976	6.63	-.00	220.32	320224.52	.27	-34.09
872	045585	HD	06/14/77	337	12	2	1976	6.63	-.00	219.80	253502.25	.29	-32.50
873	045490	HD	05/13/77	338	12	3	1976	6.63	-.12	219.96	168863.91	.48	-30.90
874	045478	HD	05/17/77	339	12	4	1976	6.63	-.00	219.96	115054.47	.14	23.30
875	045497	HD	05/17/77	340	12	5	1976	6.63	-.08	219.96	278628.26	.23	17.53
876	045484	HD	05/17/77	341	12	6	1976	6.63	-.00	219.96	263411.26	.20	18.79
877	045486	HD	05/17/77	342	12	7	1976	6.63	-.00	219.97	199641.34	.11	21.70
878	045481	HD	05/17/77	343	12	8	1976	6.63	-.00	219.97	45100.07	.17	29.67
879	045503	HD	05/17/77	344	12	9	1976	6.63	-.00	219.97	411213.88	.32	19.55
880	045483	HD	05/17/77	345	12	10	1976	6.63	-.00	219.98	380011.15	.23	19.37
881	045496	HD	05/17/77	346	12	11	1976	6.63	-.00	219.99	397510.89	.15	19.86
882	045488	HD	05/13/77	347	12	12	1976	6.63	-.00	219.99	379687.18	.28	25.52
883	045581	HD	06/15/77	348	12	13	1976	6.63	-.01	219.98	418094.67	.18	19.97

REC	AC	TAPE	PROC	DY	MN	DM	YEAR	F	LAT	LON	E1	P1	BX
884	045513	HO	05/19/77	34	12	14	1976	.62	.00	219.97	401625.94	.27	16.79
885	045575	HO	06/15/77	34	12	15	1976	.62	.00	219.95	3331023.31	.23	10.76
886	045576	HO	06/15/77	34	12	16	1976	.62	.09	219.94	232178.93	.12	19.35
887	045593	HO	05/13/77	34	12	17	1976	.62	.00	219.93	120100.51	.23	21.38
888	045518	HO	05/19/77	34	12	18	1976	.62	.01	219.92	186552.97	.27	18.20
889	045525	HO	05/19/77	34	12	19	1976	.62	.01	219.91	3099485.07	.23	19.41
890	045596	HO	06/15/77	34	12	20	1976	.62	.01	219.90	329172.49	.22	21.59
891	045553	HO	06/03/77	34	12	21	1976	.62	.00	219.90	2189336.39	.29	20.03
892	045567	HO	06/14/77	34	12	22	1976	.62	.00	219.90	219746.00	.15	25.72
893	045569	HO	06/14/77	34	12	23	1976	.62	.00	219.89	106171.89	.10	22.73
894	045582	HO	06/14/77	34	12	24	1976	.62	.00	219.89	175362.94	.27	24.49
895	045595	HO	05/13/77	34	12	25	1976	.62	.00	219.89	1533734.94	.20	22.63
896	045573	HO	06/14/77	34	12	26	1976	.62	.00	219.90	248941.93	.15	22.59
897	045570	HO	06/15/77	34	12	27	1976	.62	.00	219.90	265249.43	.21	22.81
898	045521	HO	05/18/77	34	12	28	1976	.62	.00	219.91	149528.82	.30	26.11
899	045580	HO	06/15/77	34	12	29	1976	.62	.00	219.91	181580.91	.23	26.76
900	045577	HO	06/15/77	34	12	30	1976	.62	.00	219.92	480442.37	.09	28.32
INCONSISTENT DAYS													
901	045517	HO	05/18/77	36	2	31	1976	.62	.00	219.93	319520.91	.26	17.79
902	045572	HO	06/15/77	1	1	1	1977	.62	.00	219.94	399347.03	.22	19.30
903	045512	HO	05/13/77	1	1	2	1977	.62	.00	219.90	376121.33	.25	11.00
904	045571	HO	06/15/77	1	1	3	1977	.62	.00	219.97	351736.19	.20	20.49
905	045501	HO	05/13/77	1	1	4	1977	.62	.00	219.99	184274.12	.11	21.11
906	045510	HO	05/13/77	1	1	5	1977	.62	.00	220.01	315591.21	.26	17.79
907	045594	HO	05/13/77	1	1	6	1977	.62	.02	220.03	245486.51	.16	21.27
908	045566	HO	06/15/77	1	1	7	1977	.62	.00	220.05	216076.78	.29	24.60
909	045574	HO	05/13/77	1	1	8	1977	.62	.00	220.07	258275.81	.20	23.97
910	045578	HO	06/15/77	1	1	9	1977	.62	.01	220.09	200194.42	.23	23.78
911	045579	HO	05/15/77	1	1	10	1977	.62	.00	220.07	138244.88	.18	25.65
912	045504	HO	05/19/77	1	1	11	1977	.62	.00	220.04	82448.19	.22	24.86
913	045502	HO	05/26/77	1	1	12	1977	.62	.00	220.02	185001.72	.26	20.95
914	045509	HO	05/13/77	1	1	13	1977	.62	.00	220.00	359940.77	.13	21.75
915	045506	HO	05/13/77	1	1	14	1977	.62	.01	219.99	232697.62	.26	21.07
1 DAYS MISSING													
916	045505	HO	05/13/77	16	1	16	1977	.62	.00	219.96	344615.25	.11	19.01
917	045508	HO	05/13/77	17	1	17	1977	.62	.00	219.95	284612.10	.20	20.87
918	045511	HO	05/13/77	18	1	18	1977	.62	.01	219.94	160909.08	.24	20.00
919	045590	HO	05/15/77	19	1	19	1977	.62	.00	219.93	166648.75	.20	19.44
920	045505	HO	05/13/77	20	1	20	1977	.62	.00	219.92	209981.70	.18	24.67
921	045532	HO	05/13/77	21	1	21	1977	.62	.01	219.91	246314.96	.20	22.35
1 DAYS MISSING													
922	045505	HO	06/02/77	23	1	23	1977	.62	.04	219.90	214370.80	.14	24.27
923	045505	HO	05/15/77	24	1	24	1977	.62	.01	219.90	104373.20	.20	26.60
924	045505	HO	06/15/77	25	1	25	1977	.62	.00	219.90	179959.43	.22	23.17
925	045509	HO	06/15/77	26	1	26	1977	.62	.01	219.90	150801.77	.28	18.97

ORIGINAL PAGE IS
OF POOR QUALITY

REC	AC TAPE	PROC	CY	MN	DM	YEAR	R	LAT	LON	E1	P1	BX	
926	045520	HD	05/19/77	27	1	27	1977	0.62	- .00	219.90	174159.64	.27	21.66
927	045593	HD	06/15/77	28	1	28	1977	0.62	- .00	219.90	109641.83	.15	23.92
928	045607	HD	06/15/77	28	1	28	1977	0.62	- .00	219.91	239841.38	.30	19.44
929	045605	HD	06/15/77	28	1	30	1977	0.62	- .00	219.92	351101.15	.23	21.47
930	045597	HD	06/15/77	28	1	31	1977	0.62	- .14	219.92	187329.19	.08	13.91
931	045586	HD	06/15/77	28	1	1	1977	0.62	- .09	219.93	443923.47	.20	19.68
932	045515	HD	05/13/77	28	2	2	1977	0.76	- .02	219.87	226051.57	.21	22.01
933	045526	HD	05/19/77	28	3	4	1977	0.62	- .00	219.99	307188.59	.21	19.79
934	045600	HD	06/15/77	28	2	4	1977	0.62	- .00	220.00	367643.80	.28	21.78
935	045601	HD	06/15/77	28	2	5	1977	0.62	- .00	220.00	373081.83	.26	20.03
936	045514	HD	05/13/77	28	6	6	1977	0.62	- .00	220.01	271940.89	.11	23.94
937	045522	HD	05/13/77	28	7	7	1977	0.62	- .01	220.02	456851.33	.21	19.40
938	045519	HD	05/13/77	29	2	8	1977	0.62	- .01	220.03	389491.17	.23	22.13
939	045606	HD	06/15/77	29	2	9	1977	0.62	- .00	220.04	418374.45	.17	19.77

1 DAYS MISSING

940	045516	HD	05/13/77	2	11	1977	0.62	- .00	220.06	474079.60	.25	12.52
941	045633	HD	06/30/77	2	12	1977	0.62	- .07	220.09	494661.21	.41	14.24
942	045603	HD	06/10/77	2	13	1977	0.62	- .09	220.10	445122.96	.21	17.78
943	045531	HD	05/19/77	2	14	1977	0.62	- .06	220.12	353847.63	.22	21.23
944	045587	HD	05/16/77	2	15	1977	0.62	- .00	220.14	305511.28	.24	18.54
945	045602	HD	06/15/77	2	16	1977	0.62	- .00	220.16	314867.93	.25	15.80
946	045527	HD	05/13/77	2	17	1977	0.62	- .00	220.18	295440.02	.21	19.01
947	045508	HD	05/13/77	2	18	1977	0.62	- .00	220.20	193389.04	.26	17.42
948	045523	HD	05/13/77	2	19	1977	0.62	- .00	220.23	297456.62	.15	17.73
949	045604	HD	06/13/77	2	20	1977	0.62	- .00	220.26	347458.80	.32	22.58
950	045528	HD	05/13/77	2	21	1977	0.62	- .00	220.22	243031.77	.21	26.03
951	045524	HD	05/13/77	2	22	1977	0.62	- .00	220.18	194959.65	.24	20.55
952	045555	HD	06/02/77	2	23	1977	0.62	- .00	220.15	275668.31	.22	16.88
953	045074	HD	10/26/77	2	24	1977	0.62	- .02	220.12	488576.96	.00	-1.00
954	045610	HD	06/15/77	2	25	1977	0.62	- .00	220.09	516065.03	.20	17.59
955	045529	HD	05/13/77	2	26	1977	0.62	- .00	220.06	470248.47	.33	16.83
956	045611	HD	06/15/77	2	27	1977	0.62	- .00	220.03	402088.10	.25	15.94
957	045608	HD	06/15/77	2	28	1977	0.62	- .00	220.01	380981.33	.28	20.95
958	045370	HD	04/22/77	2	28	1977	0.62	- .00	219.98	212831.27	.17	23.50
959	045371	HD	04/22/77	2	28	1977	0.62	- .00	219.96	387234.09	.32	20.06
960	045372	HD	04/22/77	2	28	1977	0.62	- .00	219.94	329330.08	.20	24.73
961	045461	HD	05/13/77	3	3	1977	0.62	- .00	219.92	207346.98	.30	18.84
962	045374	HD	04/22/77	3	3	1977	0.62	- .00	219.90	168377.79	.24	25.65
963	045373	HD	04/22/77	3	3	1977	0.62	- .00	219.88	86434.74	.23	22.33

1 DAYS MISSING

964	045363	HD	04/22/77	7	3	8	1977	-1.00	-1.00	-1.00	174563.92	.23	-1.00
965	045365	HD	04/22/77	8	3	4	1977	-1.00	-1.00	-1.00	187342.35	.17	-1.00
966	045376	HD	05/15/77	9	3	10	1977	-1.00	-1.00	-1.00	518008.65	.38	-1.00
967	045364	HD	04/22/77	0	3	11	1977	-1.00	-1.00	-1.00	559864.61	.58	-1.00

INCONSISTENT DAYS

REC	AC TAPE	PROC	DY	MN	DM	YEAR	R	LAT	LON	E1	P1	BX	
968	045464	HD	15/16/77	71	3	11	1977	5.62	-1.00	219.76	480707.08	.31	15.65
969	045609	HD	16/13/77	72	3	13	1977	-1.00	-1.00	-1.00	455962.11	.31	-1.00
970	045465	HD	05/15/77	73	3	14	1977	5.62	-1.05	219.75	517470.20	.41	18.78
971	045375	HD	05/15/77	74	3	15	1977	5.62	-1.00	219.73	485021.39	.27	22.03
972	029026	HD	12/03/77	75	3	16	1977	5.62	-1.00	219.73	351003.66	.15	16.55
973	045843	HD	10/03/77	76	3	17	1977	5.62	-1.00	219.72	135971.72	.29	16.13
974	045550	HD	05/25/77	77	3	18	1977	5.62	-1.00	219.72	391630.78	.32	19.46
975	045451	HD	05/06/77	78	3	19	1977	5.62	-1.00	219.72	434037.18	.28	21.33
976	045848	HD	10/08/77	79	3	20	1977	5.62	-1.00	219.72	301398.19	.29	27.46
977	045446	HD	05/05/77	80	3	21	1977	5.62	-1.00	219.72	408762.14	.27	22.64
978	045449	HD	05/08/77	81	3	22	1977	5.62	-1.01	219.72	360655.06	.25	17.90
979	045444	HD	05/06/77	82	3	23	1977	5.62	-1.01	219.73	410767.15	.24	17.93
980	045462	HD	05/13/77	83	3	24	1977	5.62	-1.01	219.74	298550.58	.20	16.16
1 DAYS MISSING													
981	045445	HD	05/06/77	85	3	26	1977	5.62	-1.00	219.76	417690.05	.21	22.03
982	045448	HD	05/06/77	86	3	27	1977	5.62	-1.00	219.77	466936.36	.24	18.82
983	045559	HD	06/02/77	87	3	28	1977	5.62	-1.04	219.91	312900.79	.28	19.35
984	045463	HD	05/13/77	88	3	29	1977	5.62	-1.00	219.80	346402.96	.25	19.22
985	045545	HD	05/25/77	89	3	30	1977	5.62	-1.00	219.81	377273.69	.27	19.51
986	045561	HD	06/02/77	90	3	31	1977	5.62	-1.00	219.83	329657.00	.21	19.49
987	045551	HD	05/25/77	91	4	1	1977	5.62	-1.00	219.85	273207.99	.35	23.27
988	045546	HD	05/26/77	92	4	2	1977	5.62	-1.00	219.87	242250.68	.38	23.54
1 DAYS MISSING													
989	045547	HD	05/26/77	93	4	4	1977	5.62	-1.00	219.90	213493.08	.21	19.99
990	045814	HD	09/15/77	94	4	5	1977	5.62	-1.00	219.93	500040.26	.03	16.75
991	045948	HD	05/26/77	95	4	6	1977	5.62	-1.01	219.95	415643.57	.35	13.35
992	045805	HD	03/15/77	96	4	7	1977	5.62	-1.01	219.94	330968.80	.51	11.40
993	045549	HD	05/20/77	97	4	8	1977	5.62	-1.00	219.93	477298.60	.34	17.17
994	045776	HD	09/15/77	98	4	9	1977	5.62	-1.00	219.92	501141.11	.30	11.51
995	045615	HD	06/15/77	100	4	10	1977	5.62	-1.01	219.91	523361.73	.31	-1.00
996	045875	HD	10/03/77	101	4	11	1977	5.62	-1.00	219.90	517298.72	.39	19.30
997	045635	HD	06/30/77	102	4	12	1977	5.62	-1.00	219.90	516866.91	.34	17.20
998	045634	HD	06/31/77	103	4	13	1977	5.62	-1.00	219.89	438765.09	.23	19.28
999	045616	HD	06/15/77	104	4	14	1977	5.62	-1.00	219.89	414954.37	.17	17.67
1 DAYS MISSING													
1000	045637	HD	06/30/77	106	4	16	1977	5.62	-1.00	219.88	484136.75	.30	24.43
1001	045811	HD	04/11/77	107	4	17	1977	5.62	-1.00	219.89	493085.54	.15	12.58
1002	045857	HD	06/02/77	108	4	18	1977	5.62	-1.00	219.89	485046.10	.33	16.06
1003	045556	HD	06/02/77	109	4	19	1977	5.62	-1.02	219.89	415820.36	.20	19.75
1004	045560	HD	06/02/77	110	4	20	1977	5.62	-1.00	219.90	590076.33	.64	16.28
1005	045786	HD	09/14/77	111	4	21	1977	5.62	-1.00	219.91	548616.97	.59	18.13
1006	045558	HD	05/02/77	112	4	22	1977	5.62	-1.00	219.92	507952.56	.37	17.11
1007	045791	HD	09/13/77	113	4	23	1977	5.62	-1.00	219.94	508065.34	.31	19.34
1 DAYS MISSING													

ORIGINAL PAGE IS
OF POOR QUALITY

REC	AC	TAPE	PROC	DY	MN	DM	YEAR	F	LAT	LON	E1	P1	BX
1008	045613	HD	06/17/77	115	4	25	1977	6.62	-.00	219.97	323589.67	.25	20.06
1009	045612	HD	06/15/77	116	4	26	1977	6.62	-.01	219.99	467990.96	.25	14.83
2 DAYS MISSING													
1010	045636	HD	06/30/77	119	4	29	1977	6.62	.03	220.04	254026.69	.19	27.45
1 DAYS MISSING													
1011	045614	HD	06/15/77	121	5	1	1977	6.62	-.00	220.07	361779.00	.29	9.19
1 DAYS MISSING													
1012	045794	HD	09/13/77	123	5	3	1977	6.62	-.01	220.12	517409.26	.22	14.87
3 DAYS MISSING													
1013	045777	HD	09/13/77	127	5	7	1977	6.62	-.00	220.03	387087.20	.23	12.11
1014	045772	HD	09/13/77	128	5	9	1977	6.62	-.00	220.01	357660.14	.28	12.76
1015	045771	HD	09/13/77	129	5	9	1977	6.62	-.01	219.99	369787.37	.22	19.56
1016	045797	HD	09/14/77	130	5	10	1977	6.62	.01	219.97	372453.02	.31	15.43
1017	045782	HD	09/13/77	131	5	11	1977	6.61	.42	219.99	259925.33	.38	8.99
1018	045795	HD	09/14/77	132	5	12	1977	6.62	.00	219.94	465479.39	.24	14.26
1019	045872	HD	10/12/77	133	5	13	1977	6.62	.01	219.93	438085.97	.18	10.96
1020	045774	HD	09/14/77	134	5	14	1977	6.62	-.00	219.91	403152.40	.30	13.61
1021	045773	HD	09/20/77	135	5	15	1977	6.62	-.00	219.90	135817.74	.27	14.06
1022	045781	HD	09/20/77	136	5	16	1977	6.62	.00	219.89	376660.83	.34	12.83
1023	045796	HD	09/20/77	137	5	17	1977	6.62	.00	219.89	456173.22	.26	8.41
1024	045779	HD	09/20/77	138	5	18	1977	6.62	-.00	219.89	497894.97	.32	10.83
1 DAYS MISSING													
1025	045842	HD	10/12/77	140	5	20	1977	6.62	.06	219.89	458347.64	.21	12.26
1026	045775	HD	09/15/77	141	5	21	1977	6.62	-.00	219.88	330671.76	.17	11.05
1027	045778	HD	09/15/77	142	5	22	1977	6.62	-.00	219.88	334816.93	.27	19.78
1028	045785	HD	09/15/77	143	5	23	1977	6.62	-.09	219.89	316881.71	.31	19.47
1029	045783	HD	09/13/77	144	5	24	1977	6.62	-.00	219.89	296213.20	.28	14.79
1030	045787	HD	09/13/77	145	5	25	1977	6.62	-.00	219.89	335070.93	.40	15.70
1031	045783	HD	09/13/77	146	5	26	1977	6.62	-.00	219.90	311050.61	.34	18.59
1032	045793	HD	09/13/77	147	5	27	1977	6.62	.00	219.91	294204.99	.25	15.63
1033	045789	HD	10/12/77	148	5	28	1977	6.62	.14	219.94	289802.02	.36	23.72
1034	045790	HD	09/13/77	149	5	29	1977	6.62	.01	219.94	264310.59	.26	18.37
1035	045792	HD	09/15/77	150	5	30	1977	6.62	-.00	219.95	214467.01	.32	22.66
1 DAYS MISSING													
1036	029053	HD	12/03/77	152	6	1	1977	6.61	-.07	219.97	137716.72	.16	14.29
1037	029057	HD	12/03/77	153	6	2	1977	6.62	-.02	220.00	163549.74	.22	11.78
1038	029050	HD	12/03/77	154	6	3	1977	6.62	.02	220.02	484774.25	.23	7.43
1039	045804	HD	09/15/77	155	6	4	1977	6.62	.00	220.05	454703.96	.32	11.33
1040	045808	HD	09/14/77	156	6	5	1977	6.62	-.01	220.07	351819.53	.39	14.16

REC	AC TAPE	PROC	DY	MN	DM	YEAR	R	LAT	LOX	E1	P1	BX	
1041	045812	HD	09/14/77	157	6	6	1977	6.61	- .05	220.09	440289.18	.24	11.36
1042	045808	HD	09/14/77	158	6	7	1977	6.62	- .02	220.12	307439.68	.20	13.16
1043	045799	HD	09/14/77	159	6	8	1977	6.62	- .01	220.08	229234.79	.17	11.11

INCONSISTENT DAYS

1044	045798	HD	09/14/77	160	6	8	1977	6.62	- .00	220.05	214937.05	.32	11.88
1045	045801	HD	09/14/77	161	6	10	1977	6.62	- .00	220.01	281030.71	.11	12.10
1046	045803	HD	09/14/77	162	6	11	1977	6.62	- .00	219.97	266565.78	.21	5.39
1047	045802	HD	09/14/77	163	6	12	1977	6.62	- .01	219.94	211761.01	.31	9.95
1048	045890	HD	10/07/77	164	6	13	1977	6.62	- .02	219.91	99657.03	.18	10.73
1049	045816	HD	09/14/77	165	6	14	1977	6.62	- .02	219.88	186009.61	.32	7.98
1050	045847	HD	10/07/77	166	6	15	1977	6.62	- .00	219.85	243923.70	.18	7.95
1051	045807	HD	09/14/77	167	6	16	1977	6.62	- .00	219.82	266259.83	.32	8.45
1052	029049	HD	12/03/77	168	6	17	1977	6.62	- .08	219.81	168439.37	.21	16.02

INCONSISTENT DAYS

1053	045846	HD	10/07/77	169	6	17	1977	6.62	- .01	219.77	308009.23	.38	8.67
1054	045839	HD	10/07/77	170	6	19	1977	6.62	- .02	219.75	484680.69	.14	13.28
1055	045806	HD	10/12/77	171	6	20	1977	6.62	- .01	219.73	452321.59	.22	19.75
1056	045885	HD	10/10/77	172	6	21	1977	6.62	- .00	219.71	452986.48	.25	12.35
1057	045840	HD	10/10/77	173	6	22	1977	6.62	- .00	219.69	394168.71	.21	11.94
1058	045891	HD	10/10/77	174	6	23	1977	6.62	- .01	219.82	315886.75	.29	11.26
1059	045887	HD	10/10/77	175	6	24	1977	6.62	- .01	219.82	419959.18	.39	12.14
1060	045809	HD	09/14/77	176	6	25	1977	6.62	- .01	219.81	438255.24	.18	9.75
1061	045815	HD	09/14/77	177	6	26	1977	6.62	- .00	219.81	379063.29	.28	18.74
1062	045813	HD	09/21/77	178	6	27	1977	6.62	- .01	219.81	281494.35	.17	18.42
1063	045810	HD	09/21/77	179	6	28	1977	6.62	- .00	219.81	157141.72	.33	11.88
1064	045817	HD	09/21/77	180	6	29	1977	6.62	- .01	219.82	233290.67	.28	8.39
1065	045857	HD	10/08/77	181	6	30	1977	6.62	- .01	219.82	306038.11	.31	7.58
1066	045844	HD	10/08/77	182	7	1	1977	6.62	- .01	219.83	278122.00	.34	11.06
1067	045881	HD	10/08/77	183	7	2	1977	6.62	- .00	219.83	230458.47	.20	2.79
1068	045867	HD	10/08/77	184	7	3	1977	6.62	- .02	219.84	417013.64	.15	14.51
1069	045894	HD	10/08/77	185	7	4	1977	6.62	- .00	219.85	435964.44	.29	11.36
1070	045879	HD	10/08/77	186	7	5	1977	6.62	- .00	219.86	396469.62	.27	7.23
1071	045852	HD	10/08/77	187	7	6	1977	6.62	- .00	219.88	292827.47	.27	8.55
1072	045849	HD	10/08/77	188	7	7	1977	6.62	- .01	219.89	150030.04	.24	9.89
1073	045838	HD	10/08/77	189	7	8	1977	6.62	- .00	219.90	419754.85	.18	8.85

INCONSISTENT DAYS

1074	045868	HD	10/09/77	190	7	8	1977	6.62	- .00	219.93	426000.52	.20	6.19
1075	045841	HD	10/09/77	191	7	10	1977	6.62	- .00	219.94	458734.46	.30	15.14
1076	045865	HD	10/08/77	192	7	11	1977	6.62	- .00	219.97	516073.65	.27	10.60
1077	045859	HD	10/08/77	193	7	12	1977	6.62	- .00	220.00	470018.48	.21	7.92
1078	045873	HD	10/08/77	194	7	13	1977	6.62	- .01	220.01	447944.47	.28	10.36
1079	045862	HD	10/08/77	195	7	14	1977	6.62	- .01	220.06	312183.54	.32	8.49
1080	045856	HD	10/09/77	196	7	15	1977	6.62	- .00	220.07	425571.22	.28	6.89
1081	045853	HD	10/14/77	197	7	16	1977	6.62	- .08	220.04	403276.16	.25	10.20

1 DAYS MISSING

REC	AC	TAPE	PROC	0Y	MN	JM	YEAR	R	LAT	LON	E1	P1	BX
1082	045880	HD	10/14/77	199	7	18	1977	6.62	-.00	220.00	506437.11	.23	12.14
1083	045904	HD	10/12/77	200	7	19	1977	6.62	-.08	219.98	497029.53	.43	12.33
1084	045850	HD	10/14/77	201	7	20	1977	6.62	-.00	219.96	466597.34	.15	6.63
1085	045851	HD	10/14/77	202	7	21	1977	6.62	-.01	219.95	479061.58	.23	9.28
1086	045855	HD	10/07/77	203	7	22	1977	6.62	.00	219.93	479731.25	.23	13.57
1087	045858	HD	10/07/77	204	7	23	1977	6.62	.00	219.92	464791.36	.28	14.63
1088	045878	HD	10/07/77	205	7	24	1977	6.62	-.00	219.90	459292.10	.43	18.05
1089	045861	HD	10/07/77	206	7	25	1977	6.62	-.01	219.89	333357.14	.63	14.75
1090	045869	HD	10/08/77	207	7	26	1977	6.62	.00	219.88	348674.57	.21	17.47
1091	045863	HD	10/08/77	208	7	27	1977	6.62	.00	219.87	298137.96	.95	17.96
1092	045886	HD	10/08/77	209	7	28	1977	6.62	-.01	219.87	249689.90	8.01	13.56
1093	045860	HD	10/08/77	210	7	29	1977	6.62	-.01	219.86	139655.80	113.79	20.91
1094	045870	HD	10/12/77	211	7	30	1977	6.62	-.00	219.86	524055.58	.57	11.30
1 DAYS MISSING													
1095	045889	HD	10/09/77	213	8	1	1977	6.62	-.00	219.85	451180.61	.17	12.57
INCONSISTENT DAYS													
1096	045866	HD	10/08/77	214	8	1	1977	6.62	-.00	219.85	466863.70	.45	13.49
1097	045864	HD	10/08/77	215	8	3	1977	6.62	-.00	219.85	378886.90	.27	16.50
1098	045875	HD	10/08/77	216	8	4	1977	6.62	-.12	219.87	194139.95	.24	17.18
1099	045874	HD	10/08/77	217	8	5	1977	6.62	.01	219.87	211721.17	.29	14.81
1100	045892	HD	10/08/77	218	8	6	1977	6.62	.01	219.87	493644.15	.65	8.97
1101	045884	HD	10/08/77	219	8	7	1977	6.62	-.00	219.88	538977.17	.75	17.27
1102	029041	HD	12/09/77	220	3	8	1977	6.62	-.01	219.88	517268.37	.51	15.93
INCONSISTENT DAYS													
1 DAYS MISSING													
1103	029027	HD	12/09/77	222	8	9	1977	6.62	-.01	219.90	400599.34	.28	11.95
1104	029030	HD	12/09/77	223	8	11	1977	6.62	-.01	219.92	399904.23	.18	11.68
1 DAYS MISSING													
1105	045877	HD	10/04/77	225	8	13	1977	6.62	.00	219.94	508318.02	.37	15.81
1106	045903	HD	10/12/77	226	8	14	1977	6.62	.00	219.96	521145.26	.36	15.63
1107	045883	HD	10/08/77	227	8	15	1977	6.62	-.00	219.98	483506.88	.23	12.97
1108	029045	HD	12/09/77	228	8	16	1977	6.62	.00	219.99	466262.47	.25	16.49
1109	045882	HD	10/03/77	229	8	17	1977	6.62	.01	220.01	478432.22	.29	14.56
1110	045888	HD	10/08/77	230	8	18	1977	6.62	-.01	220.07	521066.81	.17	14.48
1111	029051	HD	12/09/77	231	8	19	1977	6.62	-.01	220.05	502351.97	.32	19.37
1112	029062	HD	12/09/77	232	8	20	1977	6.62	-.01	220.03	588526.45	3.35	16.23
1113	029028	HD	12/03/77	233	8	21	1977	6.62	-.00	220.02	509098.89	.68	17.33
1114	029048	HC	12/09/77	234	8	22	1977	6.62	-.00	220.01	429358.60	.35	16.28
1 DAYS MISSING													

REC	AC	TAPE	PROC	CY	MIN	DA	YEAR	F	LAT	LON	E1	P1	BX
1115	029054	HD	12/13/77	236	8	24	1977	6.62	-.01	219.99	254313.78	.25	9.86
1116	029044	HD	12/13/77	237	8	25	1977	6.62	.01	219.98	445284.40	.24	16.14
1117	029047	HD	12/13/77	238	8	26	1977	6.62	.01	219.97	505803.98	.20	15.58
1118	029043	HD	12/03/77	239	8	27	1977	6.62	-.00	219.97	429234.27	.15	15.67
1119	029022	HD	12/03/77	240	8	28	1977	6.62	-.01	219.96	489311.12	.62	16.59
1120	029033	HD	12/09/77	241	8	29	1977	6.62	.01	219.96	472094.04	.43	15.99
1121	029023	HD	12/03/77	242	8	30	1977	6.62	-.00	219.95	459468.71	.21	15.13
1122	029031	HD	12/03/77	243	8	31	1977	6.62	.00	219.95	378169.40	.24	13.95
1123	029035	HD	12/09/77	244	8	1	1977	6.62	.01	219.96	312021.33	.27	15.75
1124	029064	HD	12/03/77	245	8	2	1977	6.62	.00	219.96	216575.82	.56	20.31
1125	029053	HD	12/09/77	246	8	3	1977	6.62	.01	219.96	168660.58	.42	13.11
1126	029056	HD	12/12/77	247	8	4	1977	6.62	.00	219.97	109074.75	.54	17.91
1127	029037	HD	12/12/77	248	8	5	1977	6.62	.01	219.98	333007.56	.65	18.29
1128	029040	HD	12/12/77	249	8	6	1977	6.62	-.00	219.99	259695.60	.44	14.49
1129	029029	HD	12/03/77	250	8	7	1977	6.62	-.02	220.00	179906.59	.44	21.36

ORIGINAL PAGE IS
OF POOR QUALITY

V. REPRINTS

**Modulation of Trapped Energetic Electrons at 6.6 R_e
by the Direction of the Interplanetary Magnetic Field**

G. A. Paulikas and J. B. Blake

Reprinted from

**Geophysical
Research
Letters**

Volume 3, Number 5, May 1976

MODULATION OF TRAPPED ENERGETIC ELECTRONS AT
6.6 R_e BY THE DIRECTION OF THE
INTERPLANETARY MAGNETIC FIELD

G. A. Paulikas and J. B. Blake
Space Sciences Laboratory

The Aerospace Corporation
El Segundo, California

Abstract. Energetic ($E > 1.6$ MeV, > 3.9 MeV) trapped electron fluxes observed at the synchronous altitude during 1974 and 1975 by an experiment aboard ATS-6 exhibit a modulation in intensity which is correlated with the passage of sector structure boundaries of the interplanetary magnetic field past the earth. The electron fluxes reach equilibrium intensities during the time the magnetosphere is in a given IMF sector which are highest in the fall for (+) sectors and highest in the spring for (-) sectors.

Introduction

We have observed a periodicity in the magnetospheric energetic electron fluxes ($E > 1$ MeV) at 6.6 R_e associated with the passage of sector boundaries (Wilcox, 1968) of the interplanetary magnetic field. The changes in electron flux, associated with each boundary passage, are the major intensity excursions of electron fluxes during conditions of low solar activity. Furthermore, maximum intensity reached by the energetic electrons in the intervals between sector boundary passage is dependent upon the direction of the interplanetary magnetic field.

Changes in the intensity of trapped energetic electrons which could be associated with changes in the conditions existing in the interplanetary medium, and thus ultimately with the properties of magnetic field and plasma structure of the solar atmosphere, have been reported by Williams (1966) and Rothwell (1968). The observations which led these authors to conclude that the outer zone was markedly responsive to the sector structure of the interplanetary medium were obtained in the time interval near solar minimum in the middle 1960's. In 1968 we used ATS-1 data on energetic electrons which were obtained between late 1966 and early 1968 at the synchronous orbit in an attempt to verify the conclusions of Williams and Rothwell. Although the experimental situation in a synchronous orbit is somewhat "cleaner" than observations made aboard low-altitude spacecraft or high-altitude spacecraft in elliptical orbits, we failed to establish that any close correlation existed between changes in the electron fluxes observed at 6.6 R_e and changes in the direction of the interplanetary field. To be sure, sector boundary passages did give rise to major excursions in the flux levels of energetic

electrons, however equally large excursions also occurred when there were no IMF boundaries in the vicinity of the earth. These conclusions, now more than five years old, were once again checked in the course of the present study using the sector boundary catalog prepared by Svaalgaard (1975)

We were thus surprised to find that omnidirectional electron fluxes (hourly averages), as determined from data obtained by The Aerospace Corporation experiment aboard ATS-6 in 1974 and 1975, exhibit a very pronounced periodicity which is very clearly associated with the passage of interplanetary magnetic-field sector boundaries. ATS-6 was stationed at 6.6 R_e and at 94°W during the time period under consideration, the experiment which yielded the data presented here is fully described in Paulikas et al. (1975). Figure 1 illustrates the observations made at noon local time. Similar plots have been constructed for other local times and these plots exhibit identical periodicities. A limited set of data from the synchronous spacecraft ATS-1, located at 150°W, and ATS-5, located at 105°W, also are available to us for portions of the time period under discussion. (ATS-5 data were graciously provided by C. E. McIlwain). Such comparisons as we have made indicate that ATS-1, ATS-5 and ATS-6 all observe the modulation; clearly the entire outer magnetosphere is involved. Evidently, strong, periodic modulation of the outer-zone trapped-particle intensities by the interaction between the magnetosphere and the interplanetary medium is a function of the general level of solar activity and emerges as the dominant process affecting the outer zone during conditions of solar minimum. During periods of high solar activity, the periodic modulation is masked by the more-or-less irregular occurrence of magnetic storms which destroy the coherence that the energetic electron fluxes would otherwise be expected to develop in response to interplanetary conditions.

Discussion

The outer-zone energetic electrons observed by ATS-6 are one of the end products of the interaction of the solar wind with the earth's magnetosphere. The magnetospheric substorm is the basic process which energizes magnetospheric plasma and transports these energetic particles into the stable-trapping region of the magnetosphere (McPherron et al., 1975). In the

absence of magnetic storms, the temporal evolution of the energetic electron population is a measure of the relative strength of the source (i.e., substorms) as compared to particle sinks. Our observations can be considered as representing an averaged, smoothed output of the solar wind-magnetosphere engine, with the equilibrium level of energetic electron fluxes indicative of the rate of occurrence of substorms, and hence the rate of "quiescent" energy transfer into the magnetosphere (Russell, 1974). In contrast, the changes in the electron fluxes at the time of boundary passage are associated with major disruption of the energetic electron population by magnetic storms.

We interpret our results using the phenomenological studies of Arnoldy (1974), Burton et al., (1975), Burch (1973), and Russell and McPherron (1973). The thrust of the findings of these authors, as summarized in the review of Russell (1974), is that the energy flow from the solar wind into magnetosphere mimics in some ways the behavior of a half-wave rectifier familiar in electronic applications. The input of energy into the magnetosphere proceeds only if the magnetosphere sees a southward component of the interplanetary magnetic field; a northward IMF component apparently inhibits the transfer of energy into the magnetosphere. Thus, to first approximation, the dynamics of the magnetosphere are a function of the orientation of the magnetosphere in solar-equatorial coordinates (the natural coordinates of the flow of the solar wind plasma). The geometrical arguments and coordinate transformations required to determine whether the magnetosphere sees a net northward or net southward component of the interplanetary magnetic field are somewhat complex and the reader should refer to the paper of Russell and McPherron (1973) for a complete and critical discussion of the problem. For our present purposes, we can summarize briefly: the interaction between solar wind and magnetosphere is expected to be strongest when the magnetosphere is immersed in a southward pointing interplanetary field. This occurs during northern hemisphere spring, when the earth is in a (-) sector of the interplanetary field, and in the fall, when the earth is in a (+) sector of the interplanetary field.

The data obtained during the fall of 1974 and presented in Figure 1 are consistent with this picture. The energetic electron fluxes appear to build up to higher levels during (+) sectors (i.e., generally southward IMF) than during (-) sectors. Note also that (-) to (+) sector transitions cause much deeper depressions in the electron flux than (+) to (-) transitions. Examination of the behavior of D_{st} for this period shows that a magnetic storm is associated with each (-) to (+) transition.

A limited set of data obtained in early 1975 (Fig. 2) verifies the expectation that in spring (-) sectors are more effective generators of energetic electron fluxes. The IMF sector structure during the time period covered by Fig. 2 is broken by days of mixed polarity, nevertheless, the data of Fig. 2 are, if anything, an even more striking demonstration that the level of energetic electron flux at 6.6

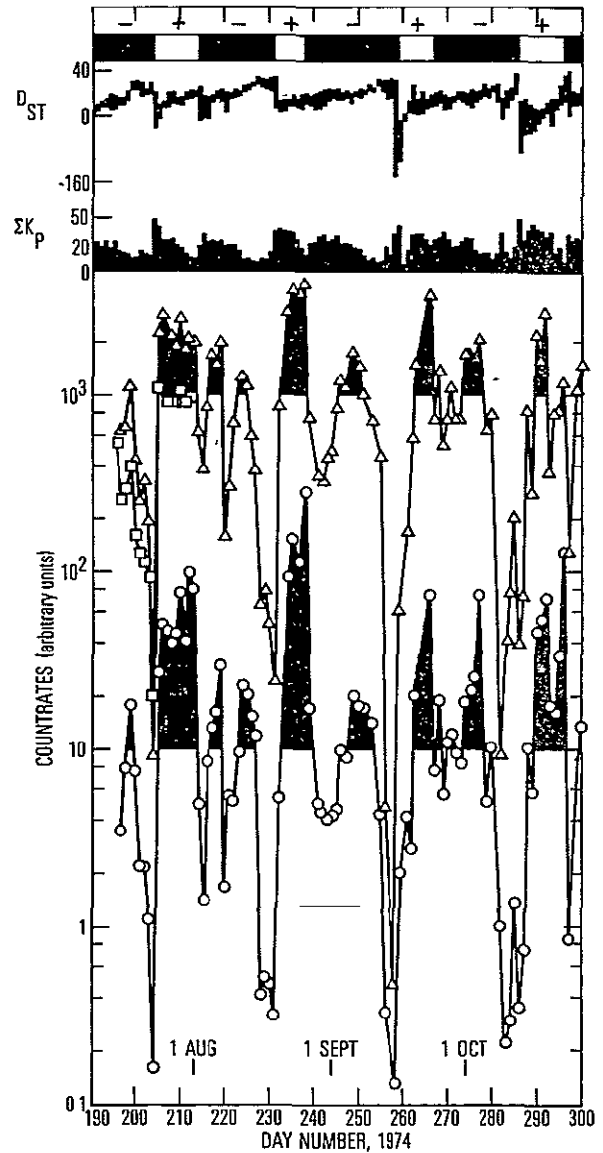

Figure 1. Hourly averages of energetic electron count rates observed in the late summer and fall of 1974 by ATS-6 and ATS-1 are plotted as a function of Day Number, 1974. Also plotted (at the top of the figure) are the polarity of the interplanetary magnetic field as inferred by Svalgaard (1975), the daily sum of K_p and the range of D_{st} for each day. Local time for all particle data is local noon, the sector boundary transitions are assumed to occur at 0000 UT for the days indicated. Circles and triangles are ATS-6 observations of > 3.9 and > 1.6 MeV electrons respectively, squares are ATS-1 observations of > 1.9 MeV electrons. For emphasis we have shaded those portions of the curves where $E > 1.6$ MeV count rates exceed $10^2/\text{sec}$ and $E > 3.9$ MeV count rates exceed $10/\text{sec}$.

R_e is a strong function of the direction of the interplanetary field.

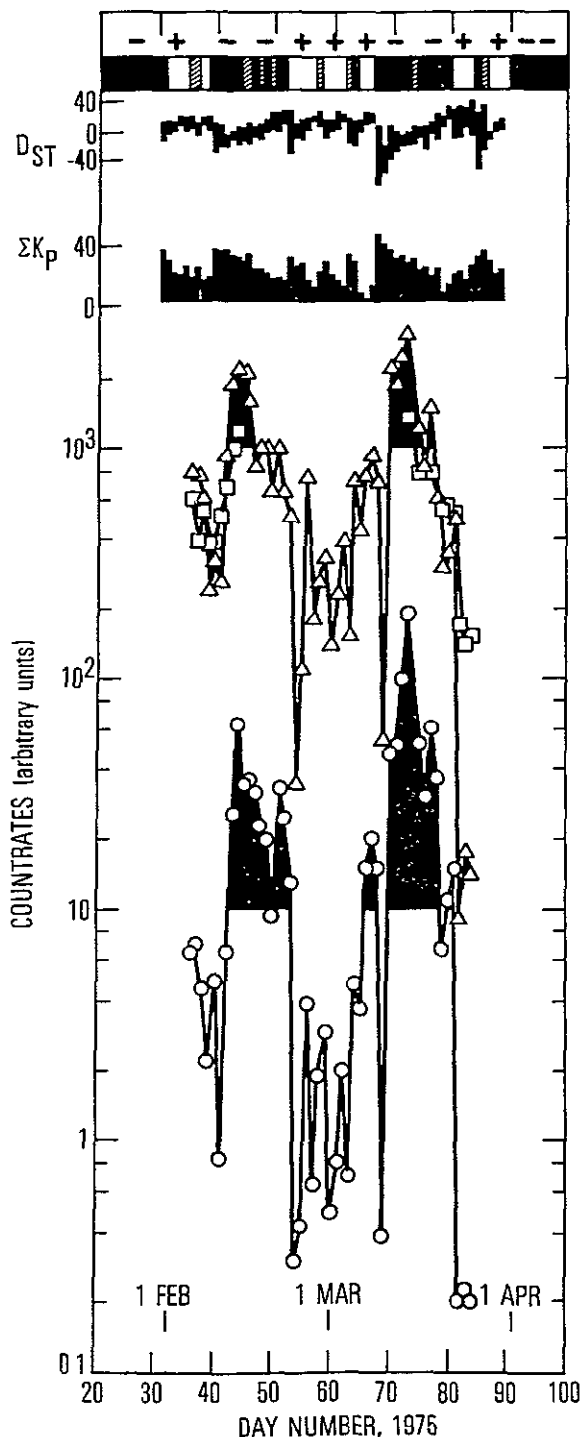

Figure 2. Hourly averages of energetic electron count rates observed in the spring of 1975 by ATS-6 and ATS-1. All other comments from the caption of Fig 1 apply. The IMF sector structure during this period exhibited some days of mixed polarity, these days are indicated by cross-hatching

At this stage of the data analysis we cannot unequivocally separate temporal changes in the electron flux from changes in the geometry of the trapping region. The work of Owens and Frank (1968) very clearly shows that the region around the earth containing energetic particles expands and contracts. ATS-6 observations, by themselves, cannot provide information regarding the extent of the trapping region. If we focus our attention on the properties of the region near ATS-6 we find, using data from the UCLA magnetometer on ATS-6 (graciously made available by R L McPherron), that during the time periods of Figs. 1 and 2 there do not appear to be any significant changes in the local field geometry at ATS-6 which are a function of the gross direction of the interplanetary field inferred by Svalgaard (1975).

It must be recalled that, because of drift shells splitting, a measurement of the omnidirectional flux by our experiment at one local time at the synchronous orbit represents the sum of the flux which exists over a range of L values at other local times. Our data have global rather than local properties. In addition, it is well known that large drift loss cones can develop in the angular distribution at synchronous altitude because of the proximity of the synchronous orbit to the trapping boundary. Such changes in the angular distribution would be interpreted by our experiment as flux changes. There are suggestions in the data, for example, in comparisons of relative flux changes at ATS-1, ATS-5 and ATS-6 as a function of IMF direction, that there may indeed be changes in the average pitch-angle distribution of energetic electrons (and therefore changes in the geometry of the trapping region) which are a function of the interplanetary field direction.

Correlations between the state of the magnetosphere and interplanetary conditions appear to be most successful when the magnetospheric parameters used in such studies represent some global characteristic of the magnetosphere. The auroral electrojet index A_e (Arnoldy, 1971), properties of polar magnetic fields (Burch, 1973), the size of the polar cap (Akasofu, 1975) and the D_{st} index (Burton, et al, 1975) are examples of such global quantities. We can now add the energetic electron fluxes at the synchronous orbit to the list of indicators of the coupling strength between the interplanetary medium and the magnetosphere.

The changes in the energetic electron flux at $6.6 R_e$ should be reflected in corresponding changes in the intensity of the energetic electrons precipitating into the atmosphere. Hence, one might expect to see aeronomic effects in and below the D-region at high latitudes (the depth in the atmosphere reached by precipitating relativistic electrons is ≈ 50 km.) The magnitude of such aeronomic effects should be a function of the direction of the interplanetary magnetic field.

Acknowledgements

The efforts of many people made our experiment on ATS-6 a success. We are particularly grateful

to Sam Imamoto, Gloria Roberts and Frances Twillie of The Aerospace Corporation, Frank McNally and Bill King of Westinghouse, and Bob Wales and Paul McKowan of NASA-Goddard. This work was supported in part by the U S. Air Force Space and Missile Systems Organization under Contract F04701-75-C-0076 and in part by the National Aeronautics and Space Administration Contract NASW-2879.

References

- Akasofu, S. I., "The Roles of the North-South Component of the Interplanetary Magnetic Field on Large Scale Auroral Dynamics Observed by the DMSP Satellite," Planet. Space Sci., 23, 1349, 1975.
- Arnoldy, R. L., "Signature in the Interplanetary Medium for Substorms," J. Geophys. Res., 76, 5189, 1971.
- Burch, J. L., "Effects of Interplanetary Magnetic Sector Structure on Auroral Zone and Polar Cap Magnetic Activity," J. Geophys. Res., 78, 1047, 1973.
- Burton, R. K., R. L. McPherron and C. T. Russell, "The Terrestrial Magnetosphere. A Half-wave Rectifier of the Interplanetary Electric Field," Science, 189, 717, 1975.
- McPherron, R. L., C. T. Russell and M. P. Aubry, "Satellite Studies of Magnetospheric Substorms on August 15, 1968. 9. Phenomenological Model for Substorms," J. Geophys. Res., 78, 3131, 1973.
- Owens, H. D., and L. A. Frank, "Electron Omnidirectional Intensity Contours in the Earth's Outer Radiation Zone at the Magnetic Equator," J. Geophys. Res., 73, 199, 1968.
- Paulikas, G. A., J. B. Blake, and S. S. Imamoto, "ATS-6 Energetic Particle Radiation Measurements at Synchronous Altitude," IEEE Trans Aerospace and Electronic Systems, AES-11, 1138, 1975.
- Rothwell, P., quoted in J. M. Wilcox, "The Interplanetary Magnetic Field, Solar Origin and Terrestrial Effects," Space Sci. Revs., 8, 258, 1968.
- Russell, C. T., "The Solar Wind and Magnetospheric Dynamics," Correlated Interplanetary and Magnetospheric Observations, edited by D. E. Page, D. Reidel Publishing Company, Dordrecht-Holland, 1974.
- Russell, C. T., and R. L. McPherron, "Semiannual Variation of Geomagnetic Activity," J. Geophys. Res., 78, 92, 1973.
- Svalgaard, L., "An Atlas of Interplanetary Sector Structure 1957-1974," Stanford University Institute for Plasma Research Report 629, June 1975.
- Williams, D. J., "A 27-Day Periodicity in Outer Zone Trapped Electron Intensities," J. Geophys. Res., 71, 1851, 1966.
- Wilcox, J. J., "The Interplanetary Magnetic Field Solar Origin and Terrestrial Effects," Space Sci. Revs., 8, 258, 1968.

(Received March 8, 1976;
accepted April 1, 1976.)

Energetic Electrons at the Synchronous Altitude 1974-1977

**G. A. Paulikas, J. B. Blake, and H. H. Hilton
Space Sciences Laboratory**

**The Ivan A. Getting Laboratories
The Aerospace Corporation
El Segundo, California 90245**

August 1977

**This work was supported, in part, by SAMSO under Contract F04701-76-C-0077 and
in part by NASA under Contracts NASW-2762, NASW-2879 and NAS5-23788.**

CONTENTS

	<u>Page</u>
Abstract	-i-
I. Introduction	1
II. Overview of the Observations	3
III. Average Fluxes and $P(F > F_x)$ Distributions	5
IV. Diurnal Variations	6
V. Effects of the Interplanetary Medium on Energetic Electrons	8
VI. Future Work	9
VII Acknowledgements	9
References	10
Figure Captions	12
Appendix A: A Description of Instrument Response	34
Appendix Figure Captions.	37

Abstract

A description of the energetic (140 kev to > 3.9 Mev) electron environment observed at the synchronous altitude during the 1974-1977 time interval is presented. These results were obtained by an experiment carried on the geostationary ATS-6 spacecraft. Observations were made at several longitudes. Electron fluxes exhibit a complex temporal behavior ranging in time scale from a diurnal variation to a semi-annual variation. Average fluxes are computed and compared with earlier studies and models.

Energetic Electrons at the Synchronous Altitude 1974-1977

I. Introduction

The synchronous orbit, because of its obvious utility for terrestrial applications, is undoubtedly the single most heavily populated orbit in space. Many spacecraft, spread over longitude, are in this orbit today, and the plans of various nations (Ref. 1, Ref. 2) emphasize an even heavier utilization of it for future communications, earth observations, meteorology, and data relay spacecraft. It is clear that the investment in such space systems is likely to run into the billions of dollars.

The premium on a precise, quantitative understanding of the space environment and the impact of the environment on space systems is enormous. Even savings of fractions of a percent, derived as a result of better information regarding the energetic radiation (for example, extending the life of a spacecraft and thus decreasing the replenishment rate) translate directly into savings which run into the tens of millions of dollars.

The purpose of this report is to summarize, in a format useful to the designers and operators of synchronous orbiting of space systems, the observations of energetic electrons at the synchronous altitude made by The Aerospace Corporation particle spectrometer flown on the ATS-6 spacecraft. Preliminary results have been reported in a series of internal reports (Refs. 3-8). In this report we shall concentrate on defining the average properties of the electron population as it existed in the 1974-1977 time interval at the synchronous orbit. Thus this report can be viewed as a sequel to earlier work (Refs. 9-12) which treated the properties of the particle population at the synchronous orbit during earlier epochs. It seems useful to begin by describing some of the salient features of the ATS-6 observing program which we conducted and to point out how the present data and results may be similar to, or differ from, earlier work because of differences in epoch, instrumentation, spacecraft orientation and the location of the spacecraft in longitude.

The observations described here were made between mid-1974 and early 1977. This time interval straddled to solar minimum (as defined by sunspot number) (Fig. 1). In contrast, earlier observation of energetic radiation at the synchronous orbit made by

instruments aboard ATS-1 and ATS-5 were made during times near the peak of solar activity: late 1966 to early 1968 in the case of ATS-1 and mid 1969 to early 1972 in the case of ATS-5. As is well known, the magnetosphere is relatively more quiescent during periods of low solar activity as contrasted to the time period near solar maximum. As we shall see below, periodic manifestations of solar-wind magnetosphere interactions emerge prominently in the ATS-6 data; in contrast, impulsive solar events which occur at frequent intervals during solar maximum and tend to mask the more regular features of magnetospheric dynamics are infrequently observed in the present data set. The ATS-6 data is thus unique because it represents the first observations of the particle populations of the synchronous orbit made during the interval near solar minimum.

The instrumentation used to obtain our data has been described elsewhere (Ref. 13); a brief summary of the relevant features is given in Appendix A. Briefly, we measured the directional fluxes of electrons in the 140-600 keV interval and the omnidirectional fluxes above thresholds of 700 keV, 1.55 MeV and 3.9 MeV. Energetic proton data were also obtained (during solar proton events; these data are not discussed here).

The ATS-6 was earth oriented so that the axes of the detectors were pointed radially outward along the earth-satellite line. Thus the (directional) 140-600 keV channel (E1) measured only one segment of the angular distribution, the precise segment depending on the (rather variable) orientation of the local magnetic field with respect to the detector axis. The omnidirectional fluxes (E2, E3, E4) obtained from the ATS-6 data were obtained from countrates registered by particles which could reach the detectors through a 2π steradian acceptance angle looking out along the earth-satellite line. In contrast, on ATS-1, for example, the rapid spin of the spacecraft coupled with a relatively slow count accumulation time served to form a true average of the in situ radiation.

During the period covered by our data, the ATS-6 spacecraft was moved several times to different longitudes. Because the geographic equator does not coincide everywhere with the geomagnetic equator, a spacecraft at the synchronous orbit may be at significantly different magnetic latitudes, depending on the longitude at which the spacecraft is stationed. ATS-6 observations began while the spacecraft was on the

equator at 94°W , where the magnetic latitude is about 11° . Subsequently the spacecraft was moved to 35°E and finally to 140°W . At both of these locations the magnetic equator is nearly coincident with the geographic equator.

The displacement of the spacecraft as little as 11° off the magnetic equator has a significant effect on the observations. We find that the geomagnetic field may quite often, particularly near local midnight, assume a configuration with a strong radial component, i.e. the magnetic field at $6.6 R_e$ appears, at these times, to assume a configuration expected to be found near the magnetotail. Such tail-like configurations are characterized by the absence of very energetic electrons. The fluxes observed at 94°W , i.e. somewhat off the magnetic equator, exhibit a significantly more dynamic behavior on the timescale of a day than seen at the magnetic equator where the geomagnetic field exhibits a more regular behavior, however, the long-term average fluxes do not reflect a very significant longitudinal difference. Spacecraft longitude is taken as a parameter in the data analysis, although, as we shall see below, temporal variations in the average particle fluxes are considerably larger than effects due to change in longitude.

For the purposes of this report, we have formed hourly averages, centered on the half hour, of all the electron data presently available to us. These hourly averages are the basic material from which further analysis proceeds. Daily averages, running 27 day averages, probability distributions are all formed from hourly averages.

II. Overview of the Observations

Figures 2 through 5 give an overview of the observations of energetic electrons from mid 1974 through early 1977. Plotted here are daily averages of the electron fluxes, together with data on the sector structure of the interplanetary magnetic field as a function of time. The location in longitude of ATS-6 and the periods of spacecraft movement are indicated on the figures and separately summarized in Table I.

The dynamic nature of the energetic electron fluxes, particularly at the higher energies, is immediately apparent. The dominant periodicity (in addition to the diurnal variations (see Refs. 11 and 15) which is not visible on a plot of daily averages) is the

TABLE I

ATS-6 Geographic and Geomagnetic Locations

Time Interval	Geographic Longitude	Magnetic Latitude*
Day 165, 1974-140, 1975	94°W	11°
Day 140, 1975-180, 1975	In transit	—
Day 180, 1975-214, 1976	35°E	5°
Day 214, 1976-330, 1976	In transit	—
Day 330, 1976-present	140°W	0°

* Derived from UCLA ATS-6 Magnetometer Data
(Courtesy R. L. McPherron)

strong modulation of the energetic electron fluxes on a timescale corresponding to the solar rotation period as well on a timescale consistent with either a two- or four-sector structure of the interplanetary field. (The effects of the interplanetary sector structure on the energetic particle population has been discussed previously in Ref. 11.).

It will be immediately appreciated by the reader that long term averages of these data, used for the purposes of accurate estimates of the radiation environment, must be approached with caution because of the large variation in the fluxes occurring on several timescales.

If we now form 27-day running averages of the data presented above, we obtain Figure 6 through 9. In these figures we again see the strong effects of solar rotation-to-rotation variability of the electron fluxes. This effect is particularly noticeable in the data for the more energetic electrons and stands out particularly well in late 1976 - early 1977. Also visible is a semi-annual variation in the energetic electron fluxes, with a maxima found near the equinoxes and minima near the solstices. To be sure, the moves of the spacecraft complicate the determination of the amplitude of this variation but it appears that the semi-annual variation is comparable to, if not greater than, the longitudinal effect. The semi-annual variation in the electron flux is presumably but a reflection of the well known semi-annual variation in geomagnetic activity (Ref. 17).

III. Average Fluxes and $P(F > F_x)$ Distributions

Using the data base discussed above, we have computed the probability distributions $P(F)$ and $P(F > F_x)$ in a manner analogous to that first described by in Ref. 18. $P(F > F_x)$ is the probability of observing a flux greater than F_x for some particular energy threshold, while $P(F)$ is the differential probability distribution. These curves have been computed for the several time intervals of interest and are presented as Figs. 10 through 15. Also computed, and indicated on the figures are u , the mean of $\log_{10} F$, J , the \log_{10} of the mean flux and s , the standard deviation about u . Note, from the $P(F)$ curves that the distribution is not necessarily gaussian in $\log_{10} F$, in contrast to assumptions made in analyses of earlier data sets.

Table II summarizes the data presented in Figs. 10-15, while Fig. 16 presents spectra of the average flux for the various longitudes and time intervals covered by our data, together with the spectrum predicted by the AE-4 model (Ref. 9, 10). The points noted below can serve as a summary of our findings.

1. At energies greater than about 1.5 Mev, the ATS-6 data indicate the presence of a somewhat harder electron spectrum than the AE-4 model would predict. At energies below ≈ 1.5 Mev, our data indicate, in general, fewer electrons than AE-4. These conclusions are, however, tempered by the fact that the electron fluxes are highly variable and one can find significant time intervals (for example the late 1966 - early 1967 interval illustrated in Figs. 14 and 15) where the spectral shape at the higher energies approached that which one might expect from AE-4.
2. Longitudinal effects (caused by differences in magnetic latitude) in the mean flux are relatively minor. This conclusion must be tempered by the fact that no systematic analysis of simultaneous observations made at several longitudes has yet been carried out. There is some limited evidence (based on ATS-1/ATS-6 comparisons, Refs. 3, 12) that longitudinal flux differences ($150^{\circ}\text{W}/94^{\circ}\text{W}$) may be as large as a factor of two.
3. Although the mean fluxes observed may not be similar, the probability distributions $P(F > F_x)$ differ show systematic differences because there are far more flux dropouts off the equator. The differences are significant only near the $P(F > F_x) \approx 1$ axis.

IV. Diurnal Variations

It is of interest to compare the diurnal variations observed at the several longitudes and at the several particle energies. The mean flux for the three available longitudes is presented in Fig. 17, 18, 19 as a function of local time. As had been found previously (Ref. 11), the diurnal variation is larger at the higher electron energies. There does not seem to be any significant systematic change of the diurnal variation with longitude.

TABLE II
 COMPARISON OF ATS-6 DATA AND AE-4 MODEL
 MEAN FLUX ($\text{cm}^{-2}\text{sec}^{-1}$)

Energy	ATS-6			AE-4	
	$94^{\circ}\text{W}, \lambda_M \approx 11^{\circ}$	$35^{\circ}\text{E}, \lambda_M \approx 0^{\circ}$	$140^{\circ}\text{W}, \lambda_M \approx 0^{\circ}$		
	Day 166, 74-Day 140, 75	Day 180, 75-Day 214, 76	Day 137, 76-Day 210, 76	Day 330, 76-Day 120, 77	
$> 140 \text{ keV}$	5.35×10^6	5.29×10^6	4.84×10^6	4.16×10^6	1.66×10^7 ($> 150 \text{ keV}$)
$> 700 \text{ keV}$	5.01×10^5	5.50×10^5	4.17×10^5	2.45×10^5	1.76×10^6
$> 1.55 \text{ MeV}$	1.32×10^2	1.35×10^5	7.76×10^4	5.37×10^4	1.75×10^5
$> 3.9 \text{ MeV}$	6.46×10^2	$6.8 \times 10^{2*}$	1.25×10^2	77.6	1.7×10^2 ($> 3.6 \text{ MeV}$)

-7-

*Day 90, 76 - 214, 76 only

V. Effects of the Interplanetary Medium on Energetic Electrons

We had earlier discovered (Ref. 14) that the flux level of the energetic electrons at the synchronous orbit - and therefore presumably the flux of energetic electrons in the entire outer magnetosphere - was modulated by the passage of the sector boundaries of the interplanetary magnetic field (IMF) past the earth. Briefly, we found that the flux levels were higher during northern hemisphere fall when the earth was immersed in a positive sector than during the passage of a negative sector of the interplanetary magnetic field. Conversely, in the spring, negative sectors served to generate higher energetic electron fluxes. This finding was found to be in agreement with the picture of solar wind-magnetosphere interaction proposed by Russell and McPherron (Ref. 17).

The findings described above were based on a very limited set of data. In the past year we have attempted to confirm and extend our conclusions using the more than 2½ years of data presently available. The relevant points can be seen by examining Figures 2-5, where we have plotted the daily averages of the energetic electron fluxes, together with the sector structure of the interplanetary field (see the caption of Figure 2 for explanation of IMF data presentation). It can be seen from these figures that the sector structure of the interplanetary field provides the dominant modulation of electron fluxes. Our conclusion that higher fluxes result in the fall from + sectors than from - sectors (and that the converse holds true in the spring) can be verified by inspection of these figures. We are now in the process of trying to assess more quantitatively the relationship between the vector of the interplanetary field and the velocity of the solar wind and the generation of energetic particles in the magnetosphere.

This study, if successful, may lead to techniques for the quantitative prediction of the energetic electron fluxes at the synchronous altitude, using as input solar wind and IMF data. It appears that using data on the local (i.e. near earth) solar wind, radiation fluxes could be predicted several days in advance because of an apparent time lag between changes in interplanetary conditions and the generation by magnetospheric processes of energetic electron fluxes. Should our knowledge of solar physics, i.e. our understanding of the structure and properties of coronal holes and the

solar wind advance sufficiently, then solar data, coupled with an appropriate understanding of interplanetary transport processes, might enable radiation predictions to be made of the order of a week ahead of time.

We mention this potential benefit, because it is clear that in the future, applications spacecraft of many varieties are likely to proliferate in the synchronous orbit (see Refs. 1 and 2, for example), and modest advances in radiation prediction - particularly for manned spaceflight applications, may yield extremely beneficial results.

VI. Future Work

We plan to update and revise this report as additional ATS-6 data are reduced and analyzed. At the time of writing (August 1977) the experiment continues to function well. With luck (and NASA's continued interest) ATS-6 will cover the rising portion of the solar activity cycle and provide unique data in this respect.

In addition, we plan to analyze ATS-1 data, which were acquired simultaneously with ATS-6 during portions of 1974, 1975 and 1976. The comparison between data from spacecraft fixed in longitude (ATS-1) and the ATS-6 which sampled a range of longitude should provide definitive information of the variation of the properties of the electron radiation with longitude at the synchronous orbit.

VII. Acknowledgments

The ATS-6 experiment which yielded the results described in this report was developed with the able assistance of Sam Imamoto and Gloria Roberts. The data reduction efforts were handled by Doretha (Ross) Mayfield. This work was carried out as part of the program of Mission Oriented Investigations and Experimentation supported at The Aerospace Corporation by the USAF Space and Missile System Organization under Contract No. F04701-76-C-0077. Portions of the data reduction efforts were supported by NASA under Contracts NASW-2762, NASW-2879 and NAS5-23788.

References

1. D. P. Hearsh, ed., Outlook for Space, NASA Report SP-386, January, 1976.
2. I. Bekey and H. Mayer, 1980-2000: Raising Our Sights for Advanced Space Systems, Aeronautics and Astronautics, 14, 34, 1976.
3. G. A. Paulikas and J. B. Blake, Electron Radiation in the Synchronous Orbit, ATM-76 (6260-20)-1, The Aerospace Corp., October, 1975.
4. G. A. Paulikas, Electron Radiation in the Synchronous Orbit (Cont'd.), ATM-76(6260-20)-3, The Aerospace Corp., August, 1976.
5. G. A. Paulikas and J. B. Blake, Electron Environment at Synchronous Altitude (Cont'd.), ATM-77(2260-20)-1, The Aerospace Corp., October, 1976.
6. G. A. Paulikas and M. Schulz, Upper Limits to the Energetic Electron Flux at the Synchronous Orbit, ATM-76(6260-20)-2, The Aerospace Corp., April, 1976.
7. G. A. Paulikas and J. B. Blake, Energetic Electron Environment at Synchronous Altitude, ATM-77(2260-20)-2, The Aerospace Corp., April, 1977.
8. G. A. Paulikas and H. H. Hilton, Radiation Environment at Synchronous as observed 1974-1977, ATM-77(2872)-9, The Aerospace Corp., June, 1977.
9. G. W. Singley and J. I. Vette, The AE-4 Model of the Outer Radiation Zone Electron Environment, NASA-NSSDC 72-06, August, 1972.
10. G. W. Singley and J. I. Vette, A Model Environment for Outer Zone Electrons, NASA-NSSDC 72-13, December, 1972.
11. G. A. Paulikas and J. B. Blake, The Particle Environment at the Synchronous Altitudes, in Models of the Trapped Radiation Environment, Vol. VII: Long Term Variations, NASA SP-3024 (1971).

12. A. L. Vampola, J. B. Blake and G. A. Paulikas, A New Study of the Outer Zone Electron Environment: A Hazard to CMOS, Paper 77-40 presented at the 15th AIAA Aerospace Sciences Meeting, Los Angeles, January 1977; to be published in Journal of Spacecraft and Rockets, October, 1977.
13. G. A. Paulikas, J. B. Blake, S. S. Imamoto, ATS-6 Energetic Particle Radiation Measurement at Synchronous Altitude, IEEE Trans. on Aerospace and Elect. Systems, AES-11, 1138, 1976.
14. G. A. Paulikas and J. B. Blake, Modulation of Trapped Energetic Electrons at $6.6 R_e$ by the Direction of the Interplanetary Magnetic Field, Geophys. Res. Lett., 3, 277, 1976.
15. G. A. Paulikas, J. B. Blake, S. C. Freden and S. S. Imamoto, Observations of Energetic Electrons at Synchronous Altitude, I. General Features and Diurnal Variations, J. Geophys. Res. 73, 4915, 1968.
16. L. Svalgaard, An Atlas of Interplanetary Sector Structure 1957-1974, SUIPR Report No. 629, Institute for Plasma Research, Stanford University, June 1975.
17. C. T. Russell and R. L. McPherron, Semiannual Variation of Geomagnetic Activity, J. Geophys. Res., 78, 92, 1973.
18. J. I. Vette and A. B. Lucero, Models of the Trapped Radiation Environment, Volume III: Electrons at the Synchronous Altitude, NASA SP-3024, 1967.

Figure Captions

- Figure 1. Relationship between the intervals of data acquisition on energetic electrons at synchronous altitudes by experiments on board ATS spacecraft and the 11-year solar activity cycle as defined by the Zurich sunspot number
- Figure 2. Daily average fluxes for 1974 for the four channels of ATS-6 electron data. The trace at the bottom of each panel gives the sector structure of the interplanetary magnetic field as determined by Svalgaard (Ref. 16). Positive sector days are indicated by the upper line, negative sector days by the lower line. Days when polarity is mixed are indicated by a point falling between the two lines.
- Figure 3. Same as Figure 1, except for 1975. The data for the > 3.9 Mev channel are suspect after Day 140, 1975 and have been deleted.
- Figure 4. Same as Figure 1, except for 1976. The data for the > 3.9 Mev channel are suspect between Day 1 and Day 90 and have been deleted.
- Figure 5. Same as Figure 1, except for 1977. Isolated days of data are indicated by unconnected points.
- Figure 6. Running 27 day average electron fluxes for the four channels of ATS-6 energetic electron data obtained in 1974. Interplanetary magnetic field sector structure is indicated on each panel of data (see Fig. 2 caption for explanation).
- Figure 7. Same as Figure 7, for 1975. $E > 3.9$ Mev data after Day 140 is suspect and have been deleted.
- Figure 8. Same as Figure 7, for 1976. $E > 3.9$ Mev data between Day 1 and Day 90 are suspect and have been deleted.
- Figure 9. Same as Figure 7, for 1977.

- Figure 10. Normalized differential probability $P(F)$ of observing a flux F_x for the four ATS-6 electron channels during the interval Day 165, 1974 to Day 140, 1975 when ATS-6 was located at 94°W . This figure was constructed by sorting the observations into bins 0.1 wide in $\log_{10} F_x$. Data for all local times are included. The electron energies are E1: 140-600 keV, E2 $>$ 700 keV, E3 $>$ 1.55 MeV and E4 $>$ 3.9 MeV. The units of F_x are $\text{cm}^{-2}\text{sec}^{-1}$ for all channels except E1 where the units are $\text{cm}^{-2}\text{sec}^{-1}\text{sr}^{-1}$ instead. The notation "ALL" on the figure indicates that all polarities of the interplanetary magnetic field are included in this analysis. The column U gives the mean of the logarithms of the (hourly average) fluxes during this interval, the column J gives the logarithm of the mean flux and S is the logarithm of the standard deviation from U.
- Figure 11. The data of Figure 10 are presented as integral probabilities $P(F > F_x)$ of observing a flux greater than F_x during the Day 165, 1974 to Day 140, 1975 time interval. All other comments apply.
- Figure 12. Same as Figure 10, except the time interval is Day 180, 1975 to Day 214, 1976 where ATS-6 was located at 35°E . The E4 curve contains data from the interval 90, 76 to 214, 76.
- Figure 13. The data of Figure 12 are presented as integral probabilities of observing a flux greater than F_x during the Day 180, 1975 to Day 214, 1976 time interval. All other comments apply.
- Figure 14. Same as Figure 10, except the time interval is Day 330, 1976 to Day 120, 1977 where ATS-6 was located at 140°W . The prominent peak in E4 near an apparent flux of $\approx 10 \text{ cm}^{-2}\text{sec}^{-1}$ is due to the galactic cosmic ray background (see Appendix A) because the energetic electron flux was very low during this time period -see Figures 4, 5, and 8, 9.
- Figure 15. The data of Figure 14 are presented as integral probabilities of observing a flux greater than F_x during the Day 330, 1976 to Day 120, 1977 time interval. All other comments apply. Note that for a flux of $\approx 15 \text{ cm}^{-2}\text{sec}^{-1}$ in the E4 channel all "electrons" are really galactic cosmic rays or their products.

- Figure 16. Electron energy spectra constructed using the average fluxes for each time interval indicated. The fluxes measured in the 140-600 keV directional channel have been multiplied by 4π to obtain a measure of the omnidirectional flux in this energy interval. The $E_e > 3.9$ Mev point associated with the Day 180, 1975 to Day 214, 1976 curve was obtained using data from the Day 92, 1976 to Day 210, 1976 interval.
- Figure 17. Diurnal variation of the average electron flux observed during the time interval Day 165, 1974 - Day 140, 1975 when ATS-6 was located at 94°W .
- Figure 18. Same as Figure 17, except that the time interval is Day 180, 1975 to Day 214, 1976 when ATS-6 was located at 35°E . The E4 channel is not shown.
- Figure 19. Same as Figure 17, except that the time interval is Day 330, 1976 to Day 120, 1977. ATS-6 was at 140°W at this time.

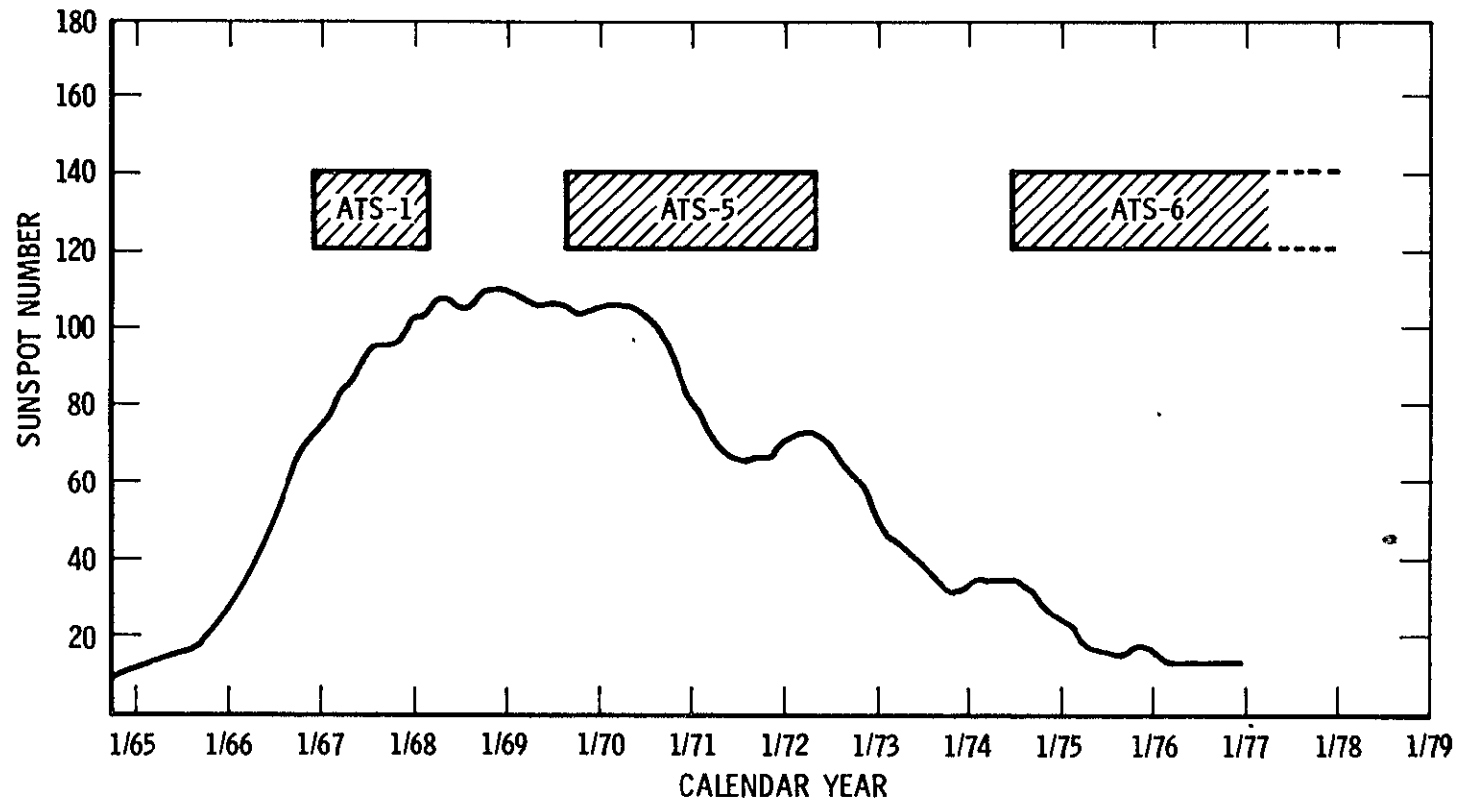

Fig.
1

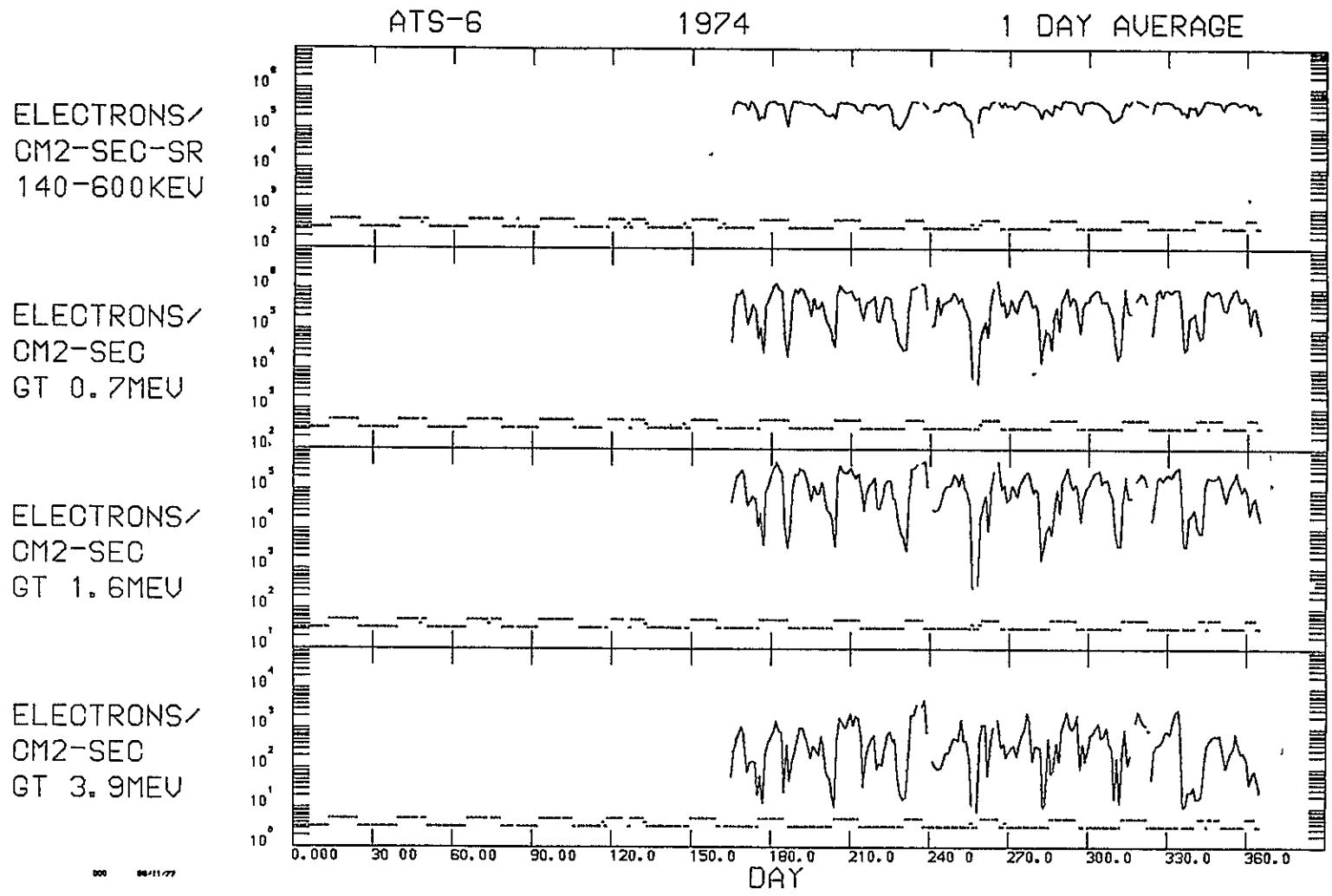
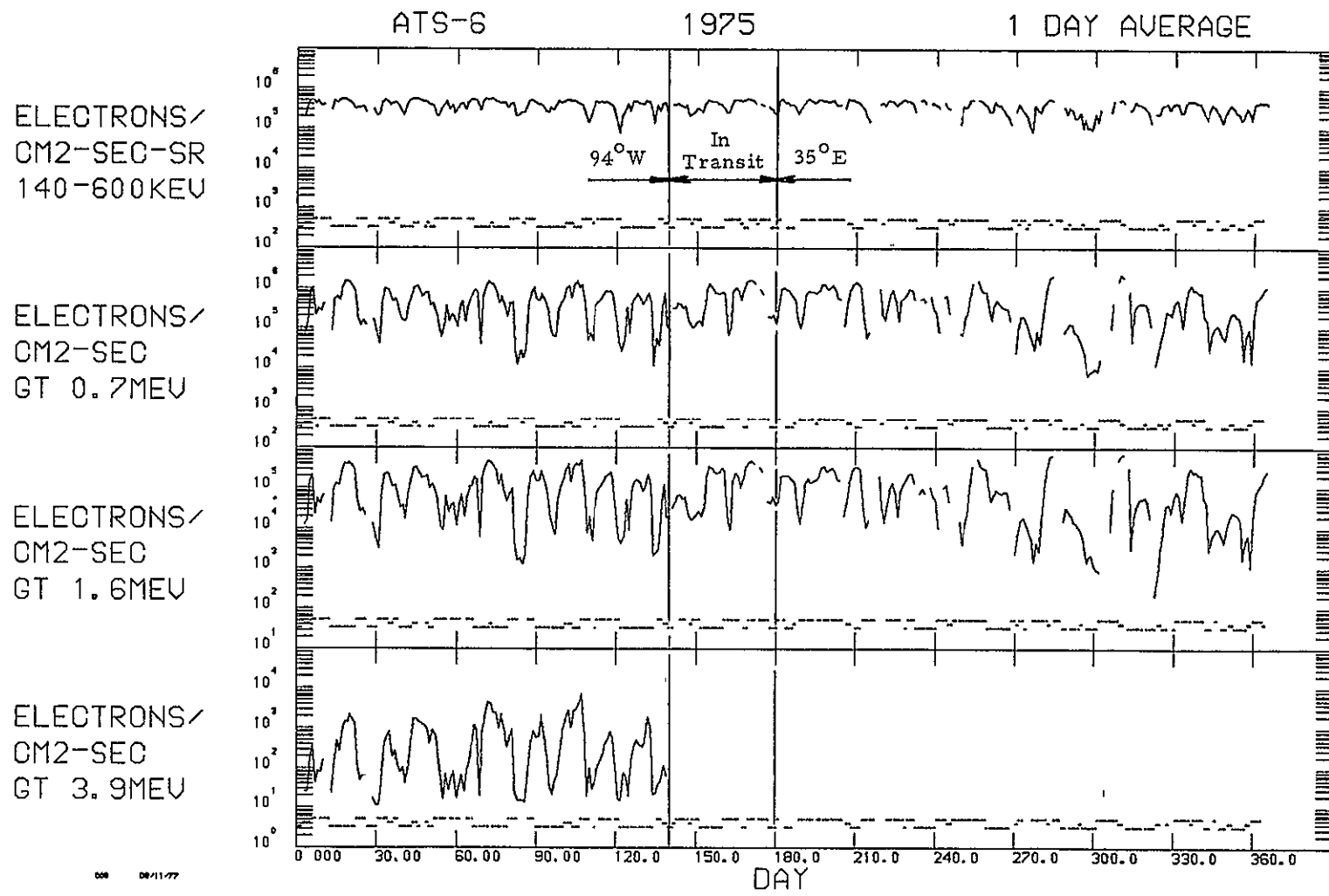

Fig.
2

00 001177

-68-



000 08/11/77

Fig.
3

-06-

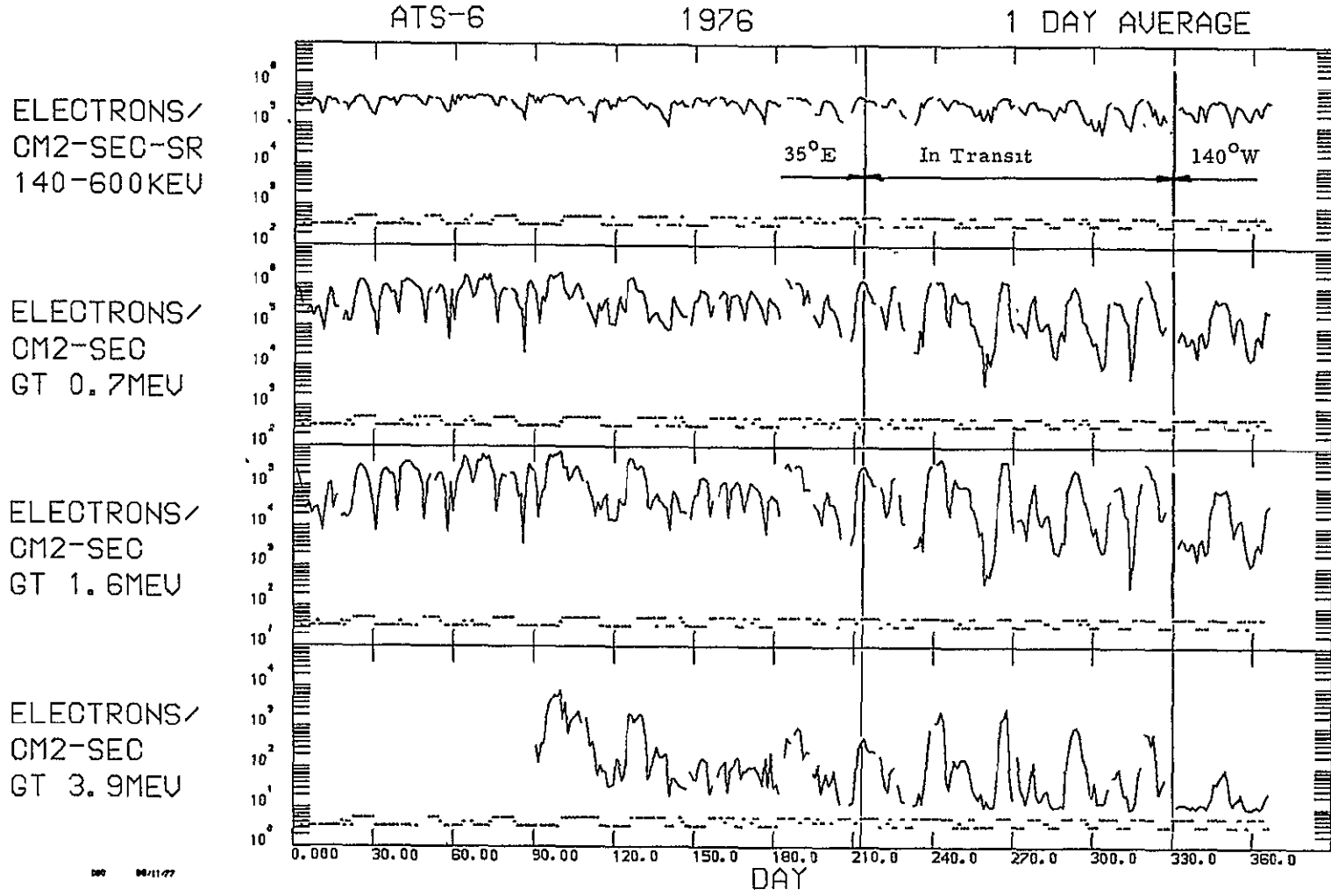

980 06/11/77

Fig.
4

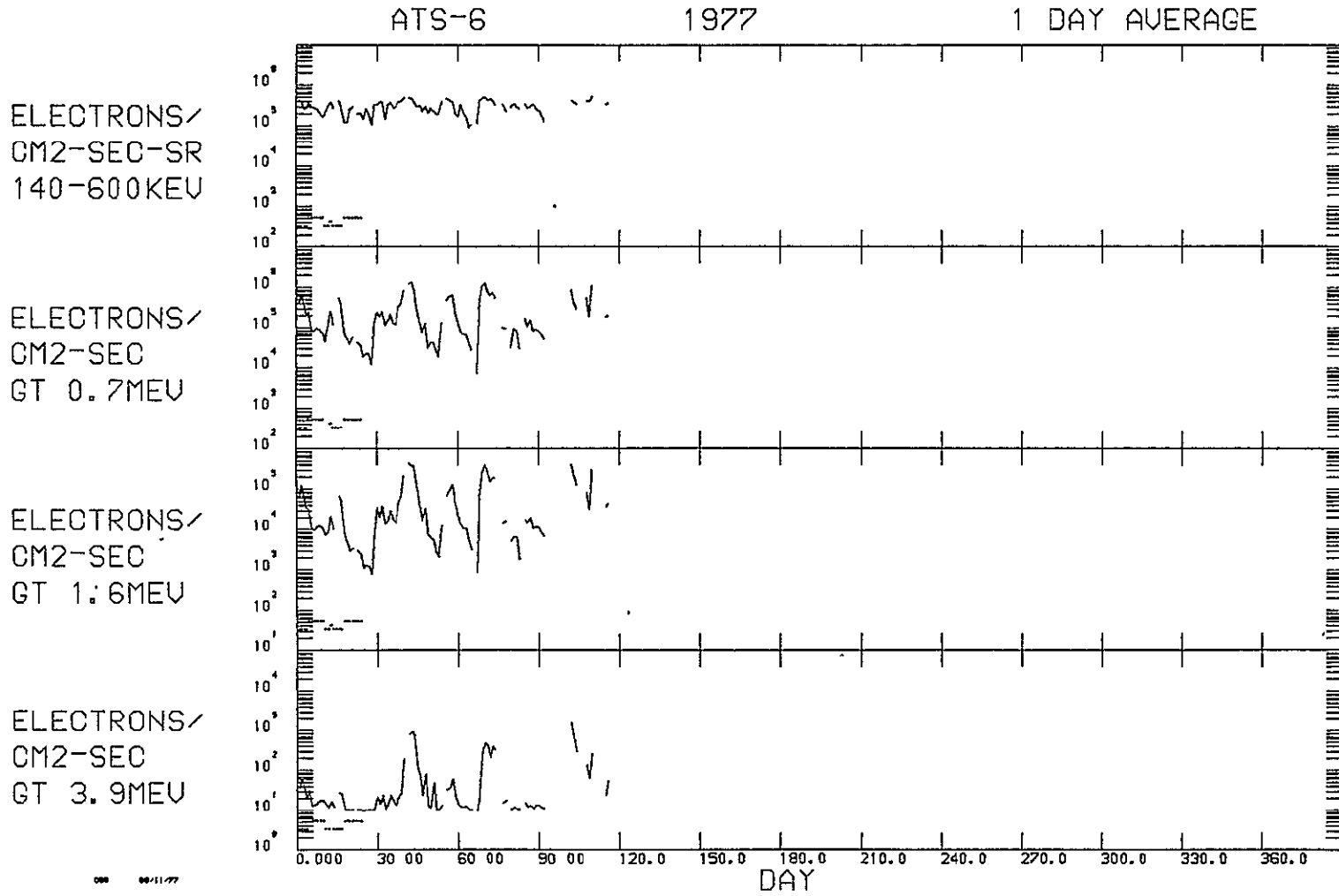
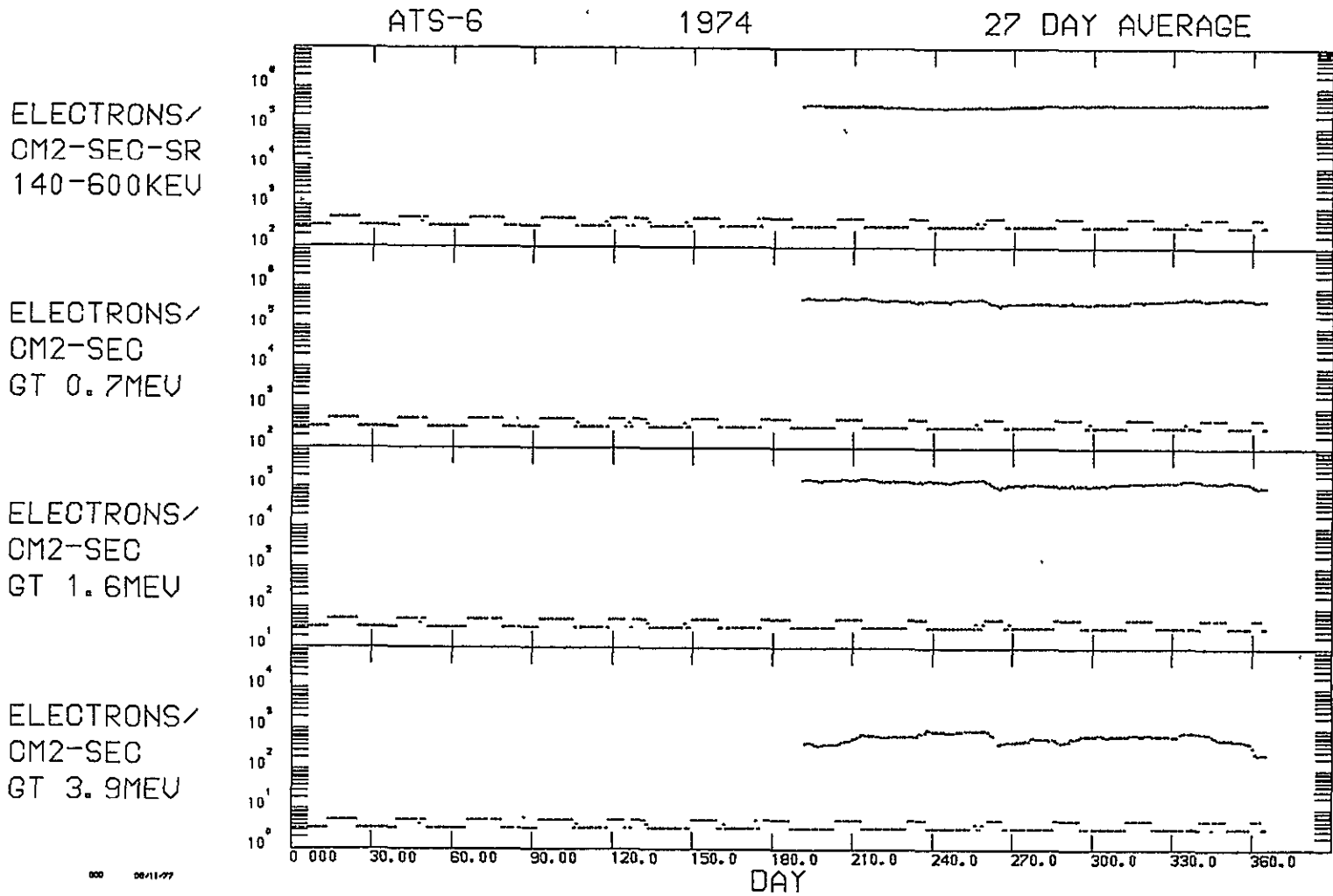

Fig.
5



00 08/11/77

Fig.
6

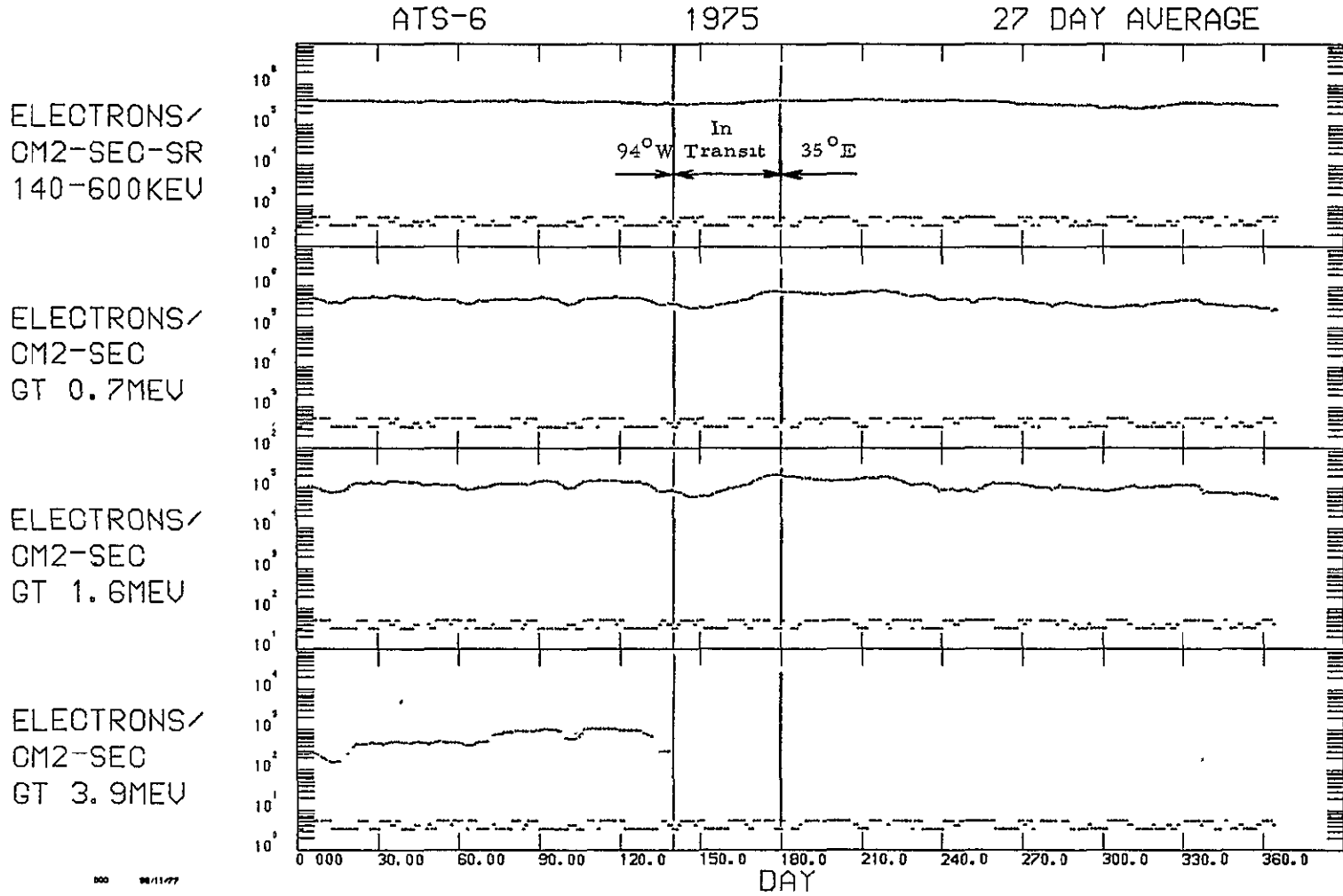

Fig.
7

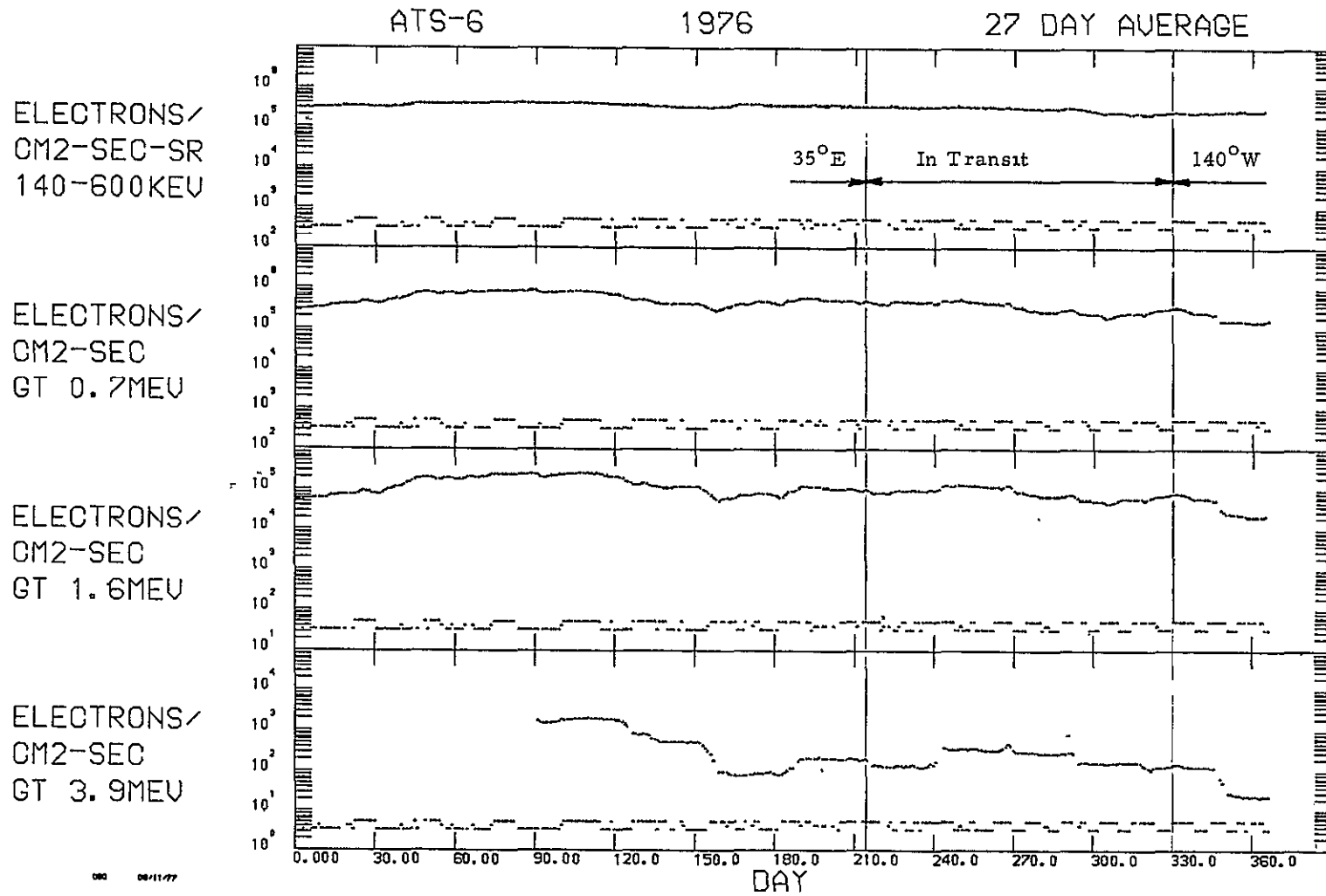

Fig.
8

-95-

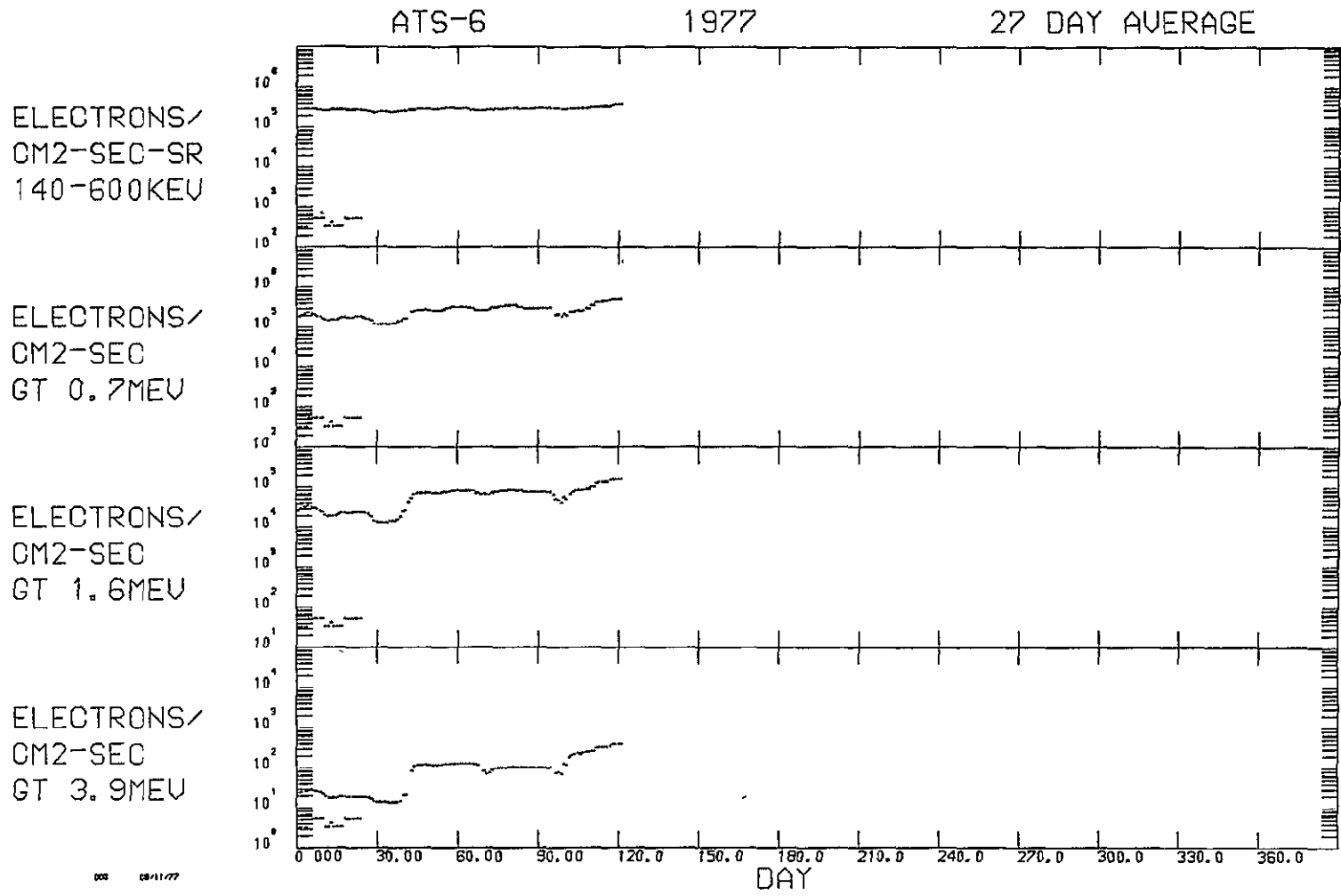

Fig.
9

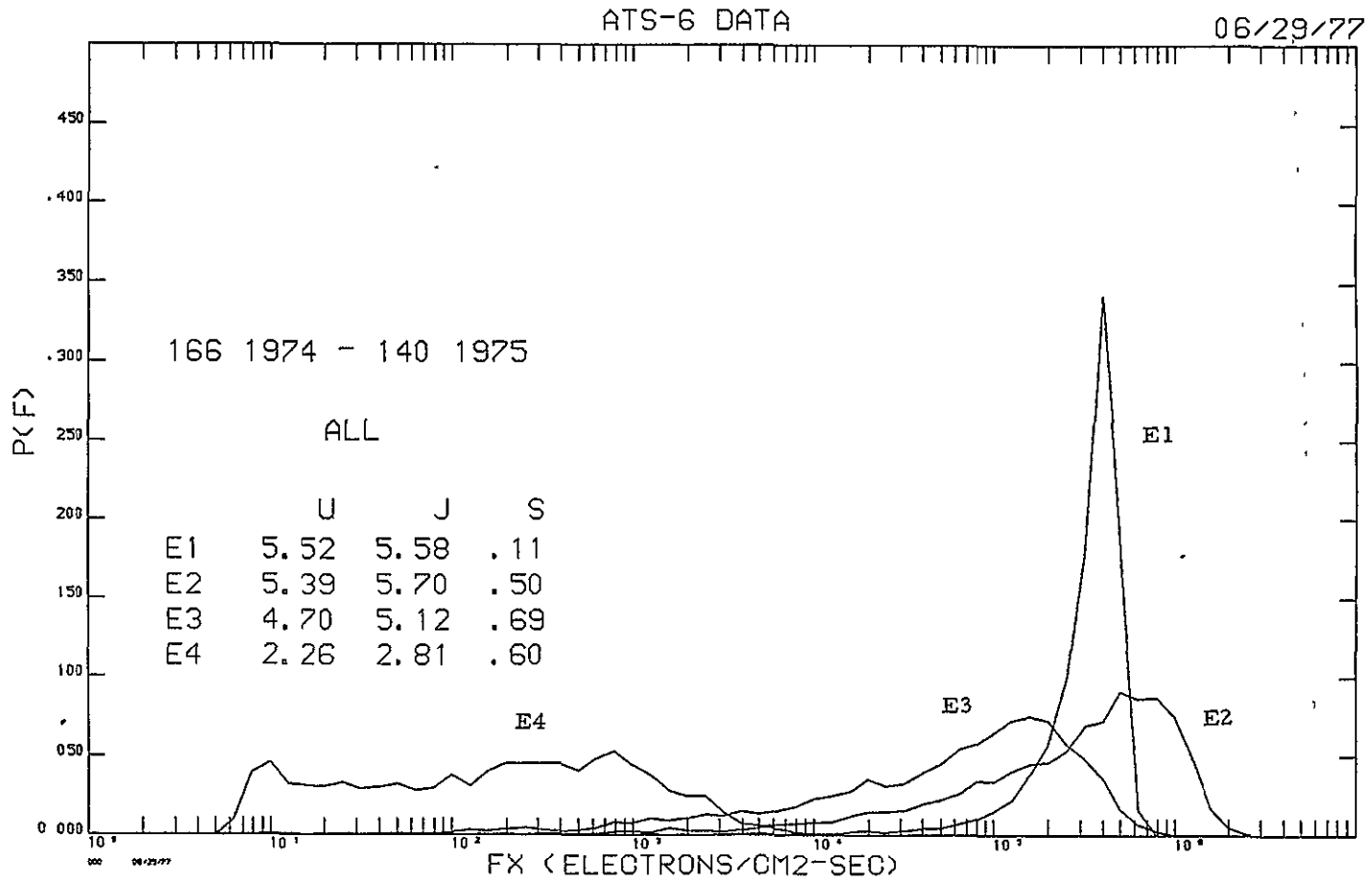

Fig.
10

U2

-97-

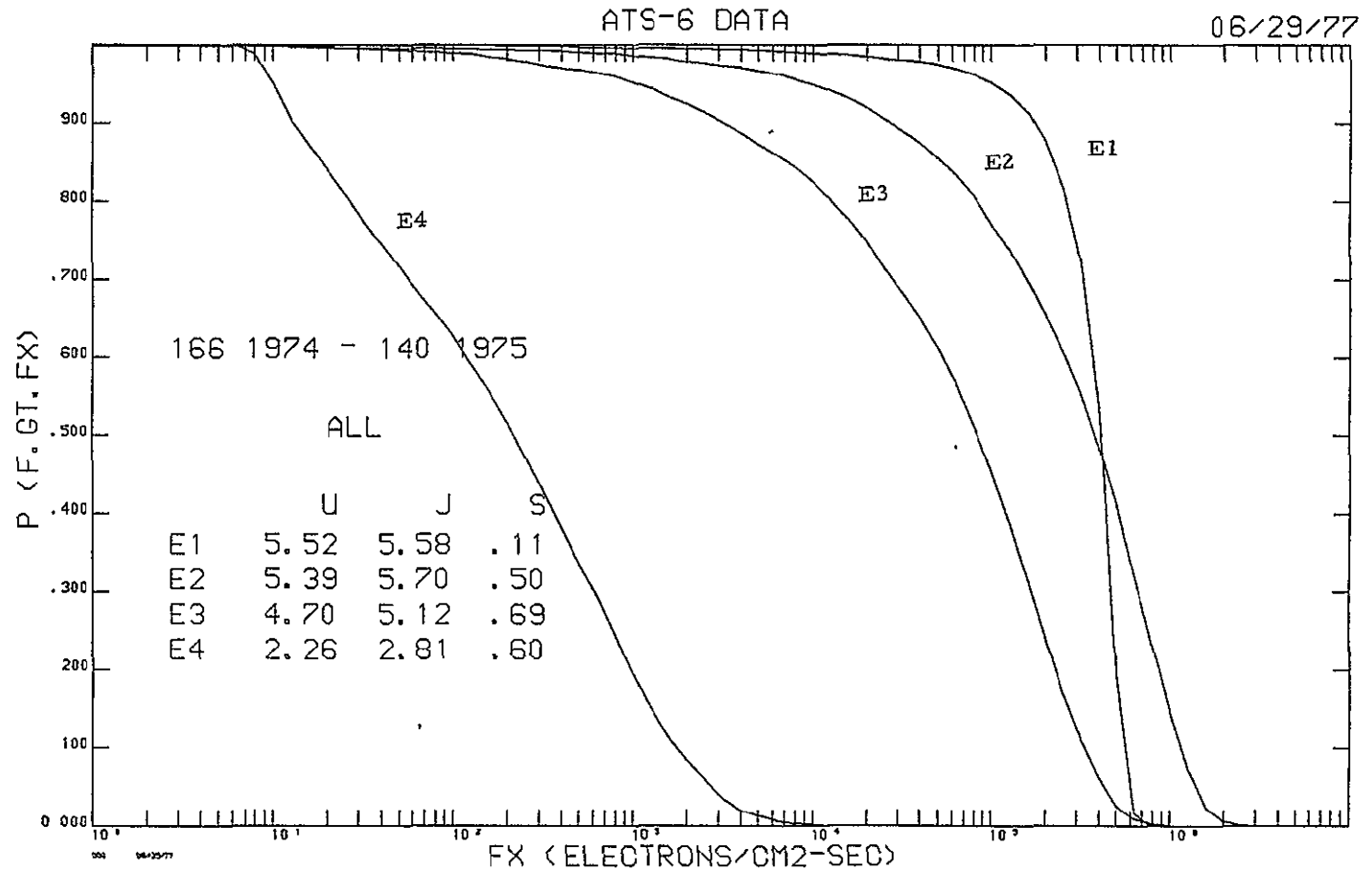

Fig.
11

-86-

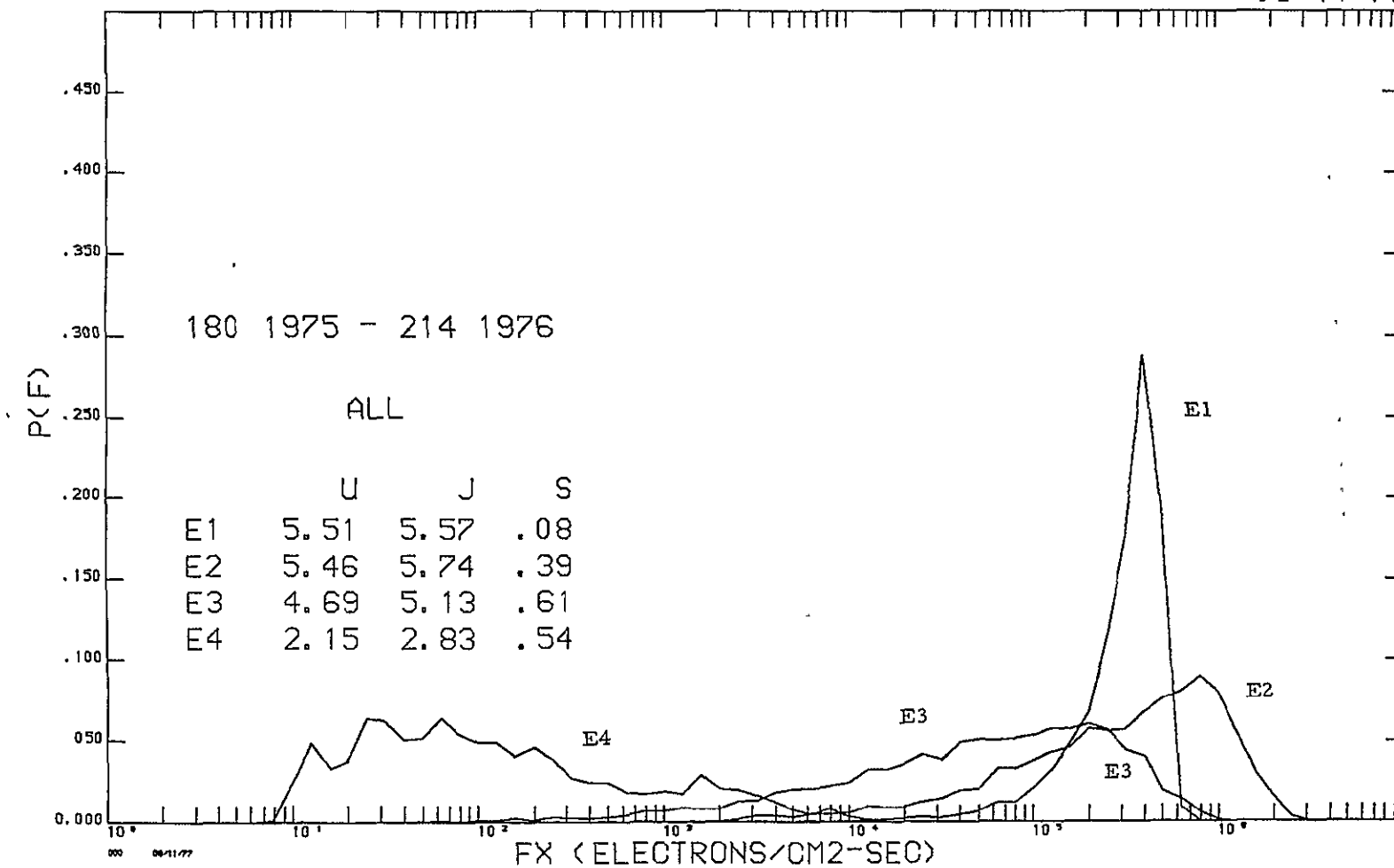

Fig.
12

ATS-6 DATA

08/11/77

-66-

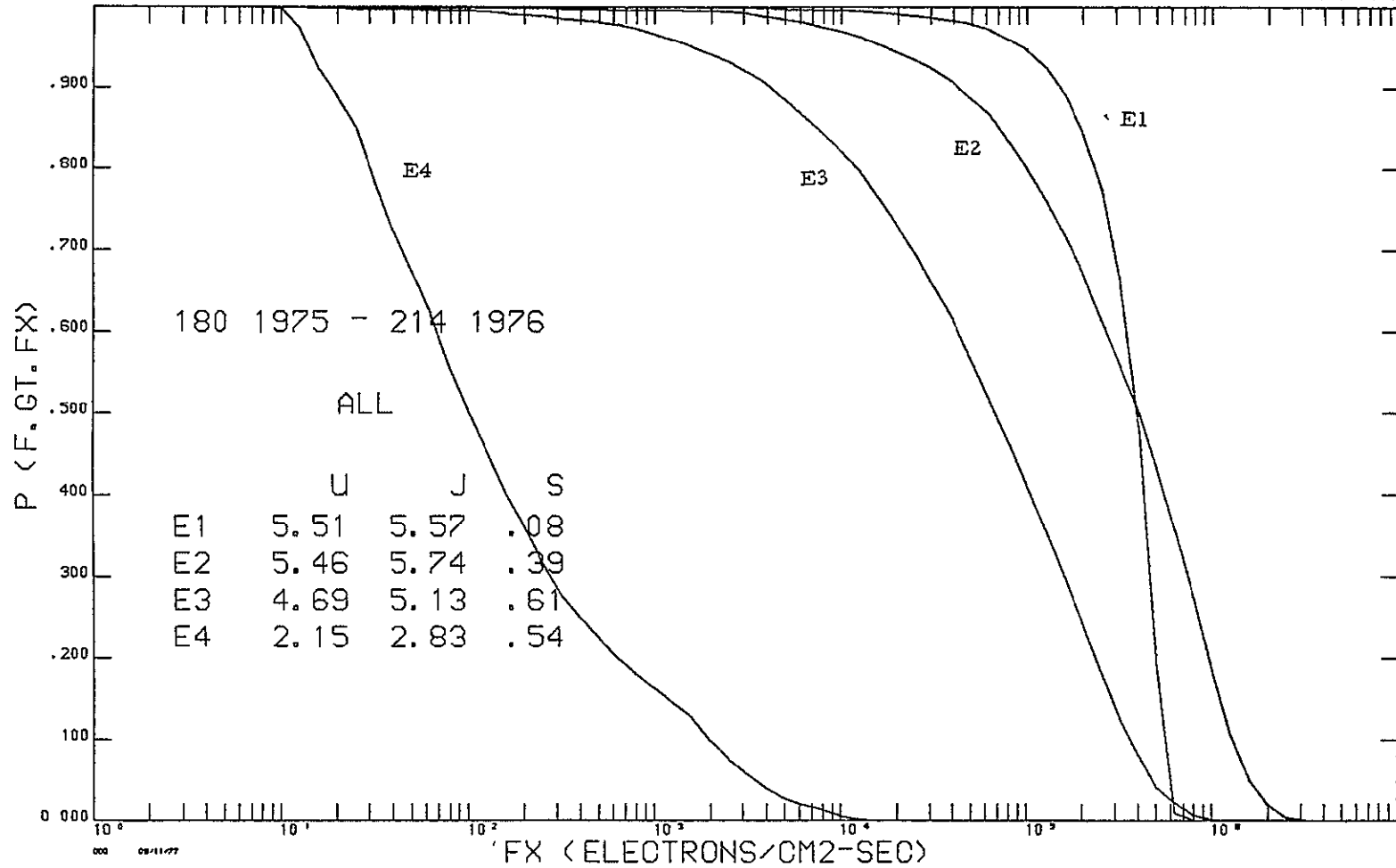

Fig.
13

-100-

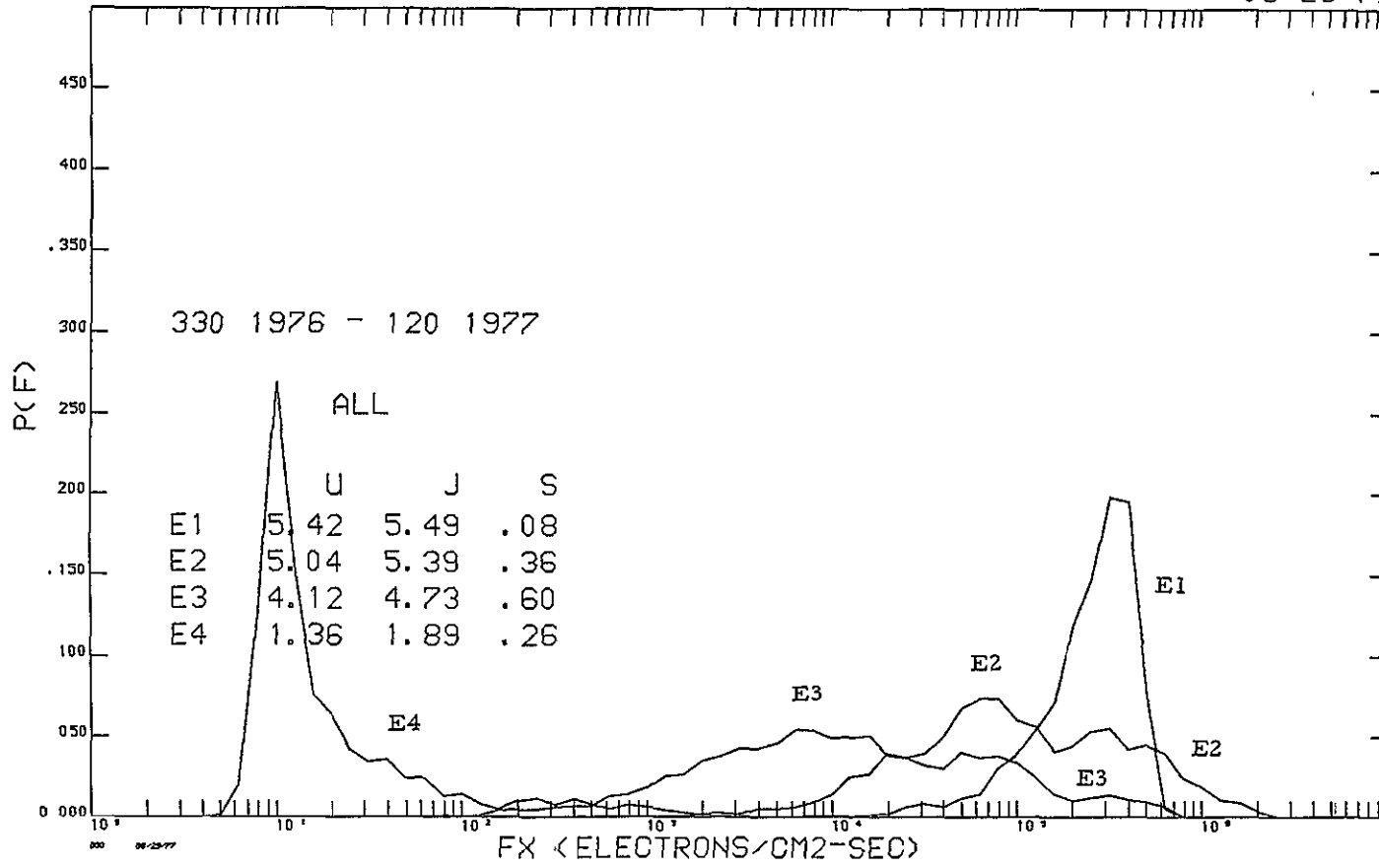

Fig.
14

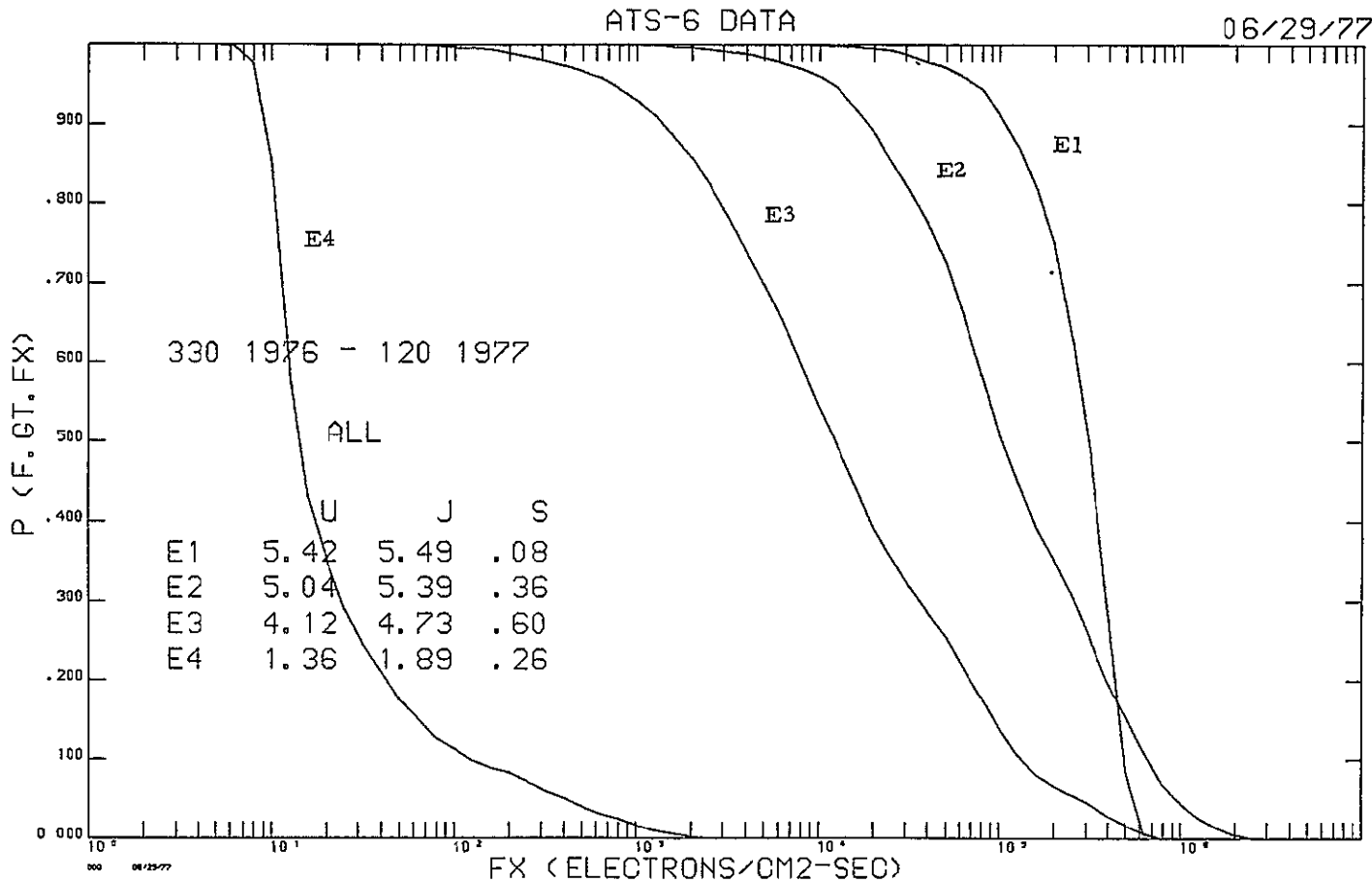

Fig.
15

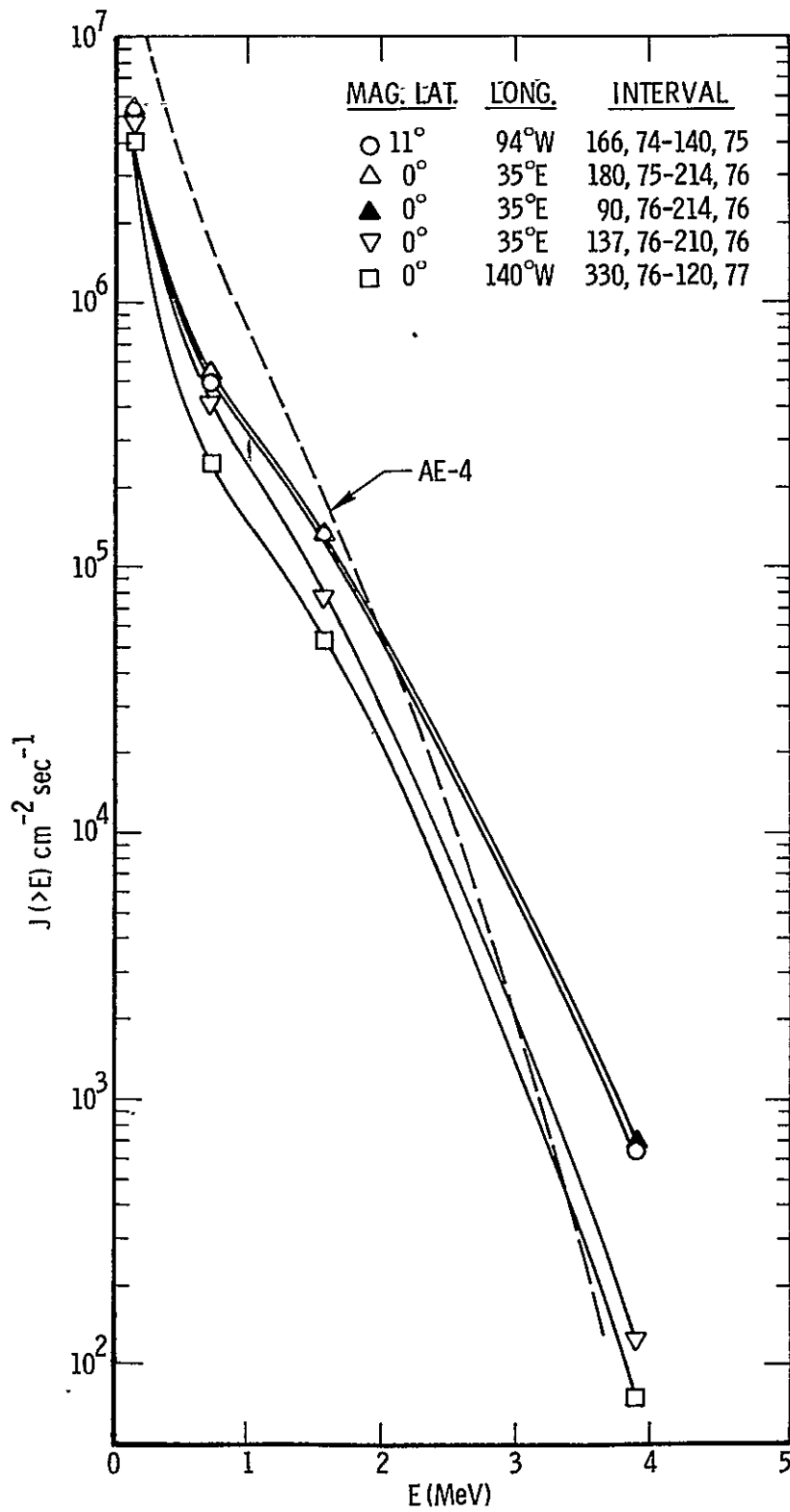

Fig. 16.

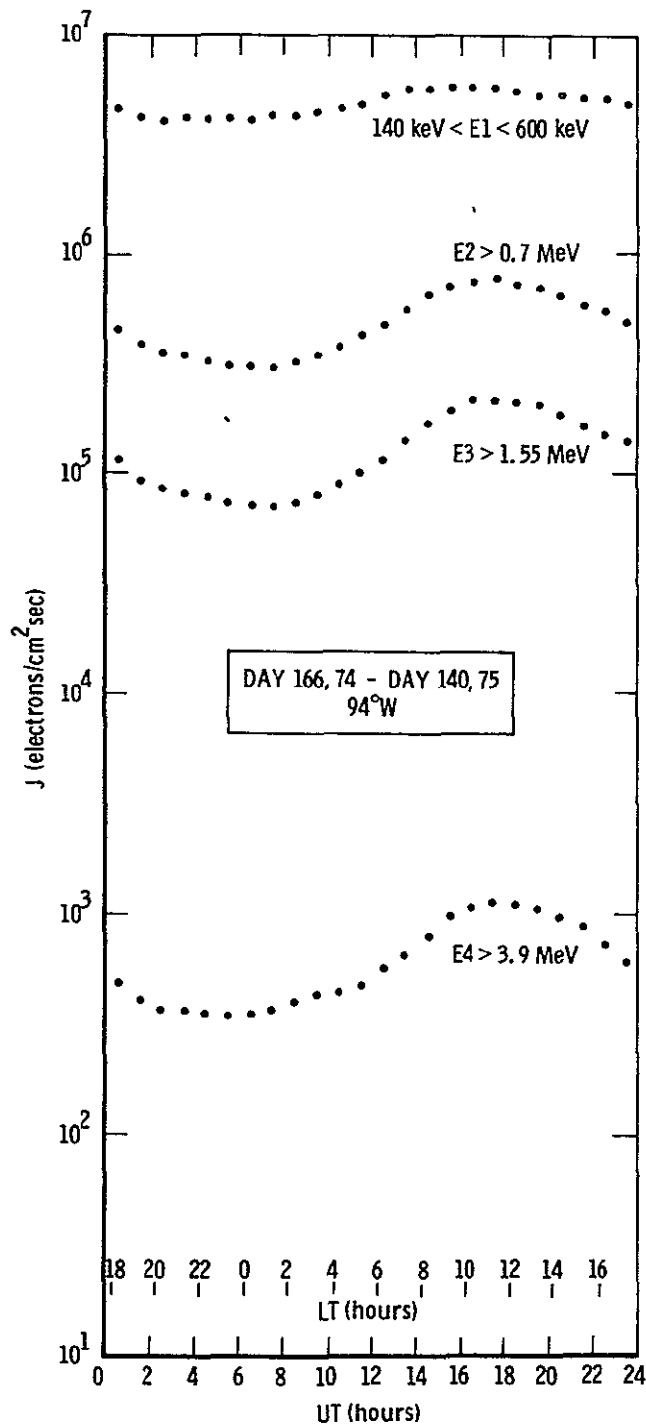

Fig.
17

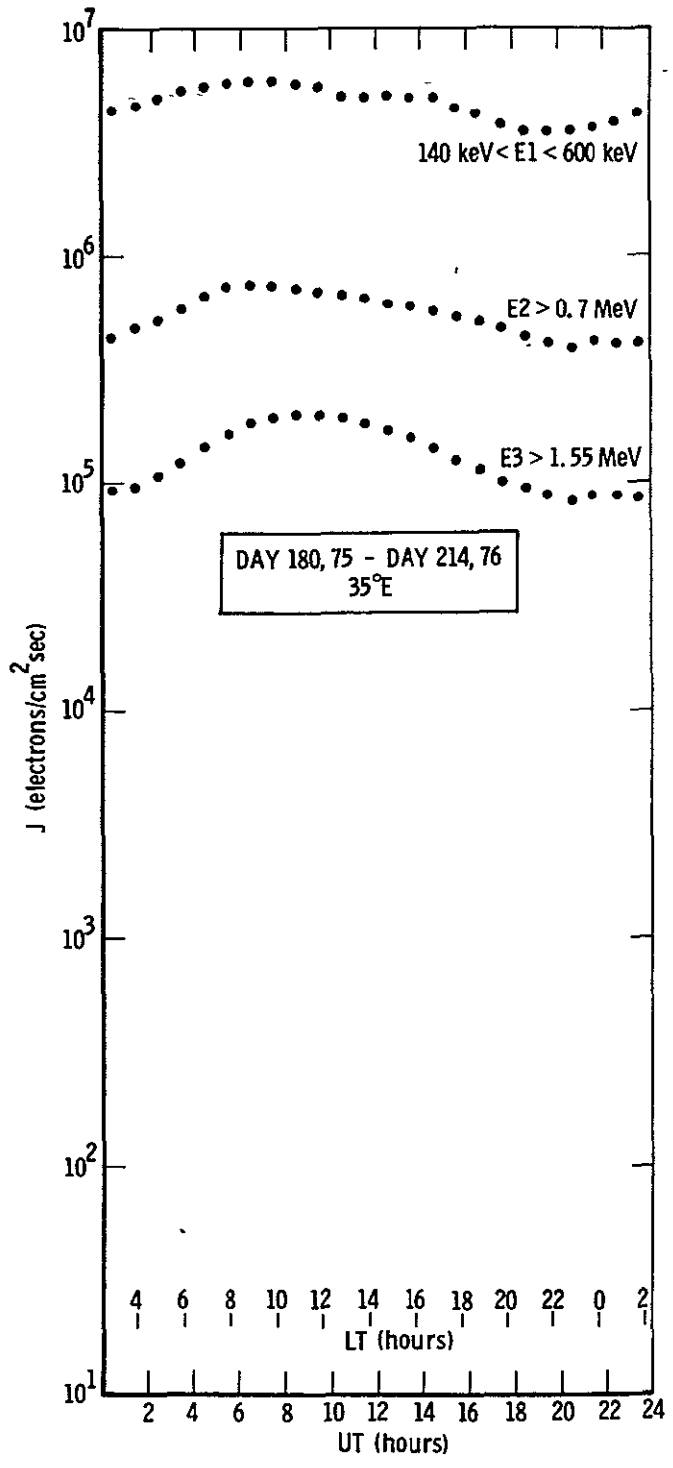

Fig. 18

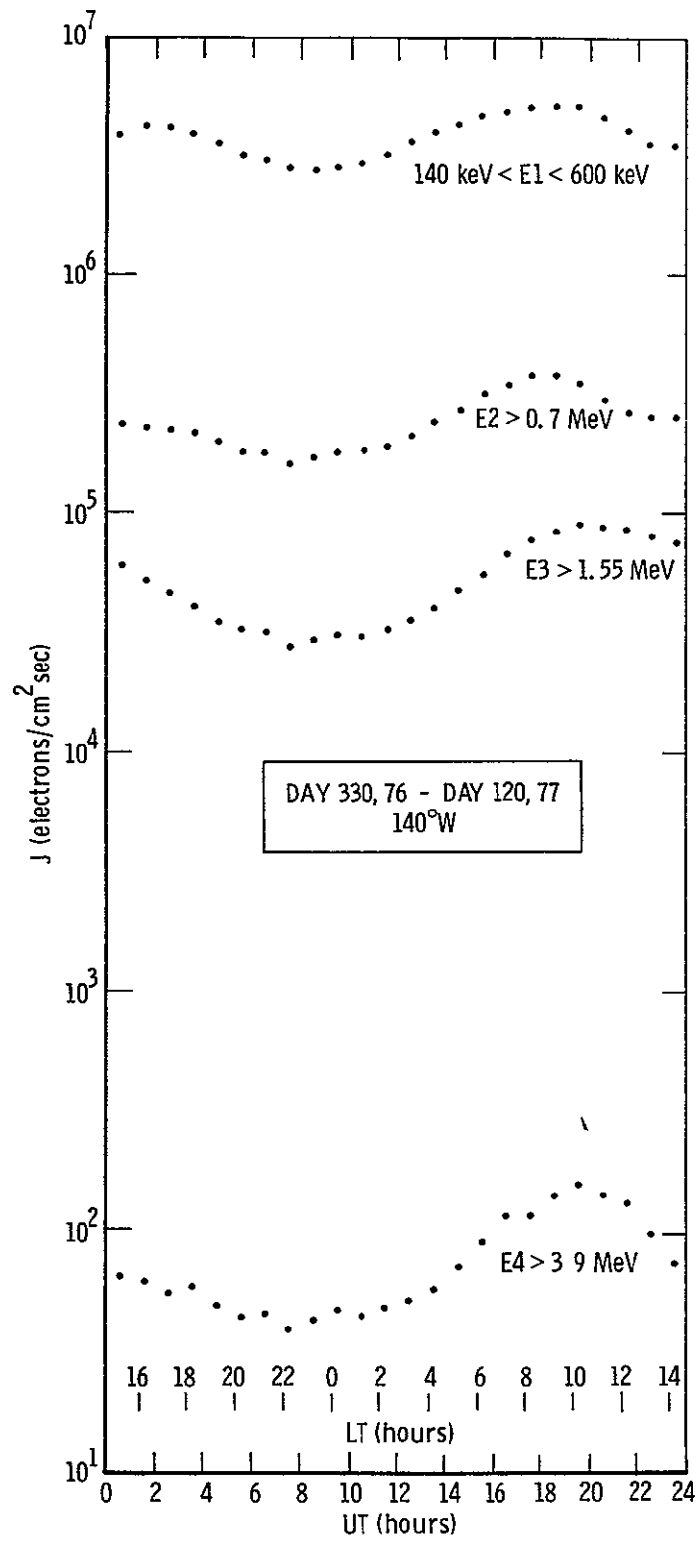

Fig. 19

Appendix A: A Description of Instrument Response

A full description of the ATS-6 Aerospace Corporation experiment has been presented in Ref. 13. Here we summarize, for ready reference, those salient features of the instrument response which may be of interest or assistance in interpretation of the results presented in earlier portions of this report.

Instrument Description

Figure A-1 shows a schematic block diagram of the detector/electronic system. The electron channels, E1, E2, E3, E4 are derived from Sensors 1-4 respectively. Figure A-2 shows the experiment.

Electron Detection

The responses of the electron channels are illustrated in Figures A-3 and A-4 respectively. These data, integrated over the angular acceptance angles of each detector give the average detector geometric factor as a function of energy. It has proven convenient to integrate these energy dependent geometric factors over various (assumed) shapes of the incident electron spectrum and finding a threshold (or set of thresholds for the E1 channel) which minimizes the variation of the geometric factor with spectral shape. The results are presented in Table A-1. The ϵ G factors given in this table were used to convert from counts to flux above the indicated thresholds (or, for E1, in the indicated energy interval).

Proton Contamination

Proton channels which measure trapped and solar proton fluxes are also associated with each detector. In principle, the proton data can be used to correct for any proton contamination of the electron data. In practice, we found that during the 1974-1977 interval, solar proton activity was very low and no systematic correction was required; instead, days of data where some solar proton contamination (primarily of the E3, E4 channels) was suspected were rejected from the analysis. The sporadic fluxes of low energy (several Mev) trapped protons which we occasionally observed did not have any effect on the electron channels. Galactic cosmic rays and the products generated by their interaction with the spacecraft gave

rise to a significant background in the E4 channel. This background has a diurnal signature characteristic of cosmic rays (i.e. a maximum near local midnight and a minimum near local noon). During time periods when the trapped electron flux was low, for example the late 1976 - early 1977 time period, this background can be clearly visible in the E4 data (see Fig. 5) as an apparent flux of $\approx 10 \text{ cm}^{-2}\text{sec}^{-1}$. The true flux is more likely $\approx 5 \text{ cm}^{-2}\text{sec}^{-1}$ because the geometric factor of the E4 channel for these very energetic, minimum ionizing particles is a factor of two larger than quoted in Table A-1. This background has not been subtracted from our results; although of galactic origin, the radiation masquerading as "energetic electrons" is always present at the synchronous orbit, is practically indistinguishable from energetic electrons, and may be of some practical consequence as an ever-present background.

Bremsstrahlung Effects

During our calibrations, the bremsstrahlung efficiencies of the E2, E3, E4 channels were measured. Upper limits for the efficiencies were determined; those upper limits fall well below 10^{-4} relative to the direct detection of electrons. In all cases, we find that the galactic cosmic ray background exceeds that which might be generated by bremsstrahlung.

Accuracy of Results

The dominant source of error in this experiment arises because of the uncertainty, estimated to be $\approx 20\%$, in the geometric factors. All other experimental sources of error are minimal. While, under some circumstances, counting statistics may contribute additional uncertainty, in this paper we are dealing with long term flux averages which effectively eliminate counting statistics on an error source. It is important to reiterate that our measurements deal with a high variable phenomenon characterized by significant deviations from the mean. Comparisons of our results with those of others need to take this into account and also recognize that important long term effects (related to the 11 year solar cycle) in the structure of the radiation belts exist.

TABLE-A-1
Omnidirectional Geometric Factors

Channel	Passband or Threshold (Mev)	ϵG
E1	0.140-0.600	0.115 cm ² sr
E2	0.700	0.00349 cm ²
E3	1.55	0.0176 cm ²
E4	3.90	0.0688 cm ²

Appendix Figure Captions

- Figure A-1 Schematic block diagram of detector/electronic system.
- Figure A-2. Overall view of the energetic particle spectrometer on ATS-6. Directional detectors (E1 channel) are housed inside the cylindrical collimator structure in the foreground.
- Figure A-3. Efficiency of detection of electrons in the E1 channel. This channel has a nominal energy sensitivity of 140-600 keV. Sensitivity of this channel below the nominal electronic threshold is associated with the finite noise of the detector.
- Figure A-4. Effective area of the E2, E3 and E4 electron channels as a function of electron energy. This effective area, when integrated over the angular response of the detector, yields the omnidirectional geometric factor. Bremsstrahlung efficiencies fall well below lower limits of this figure.

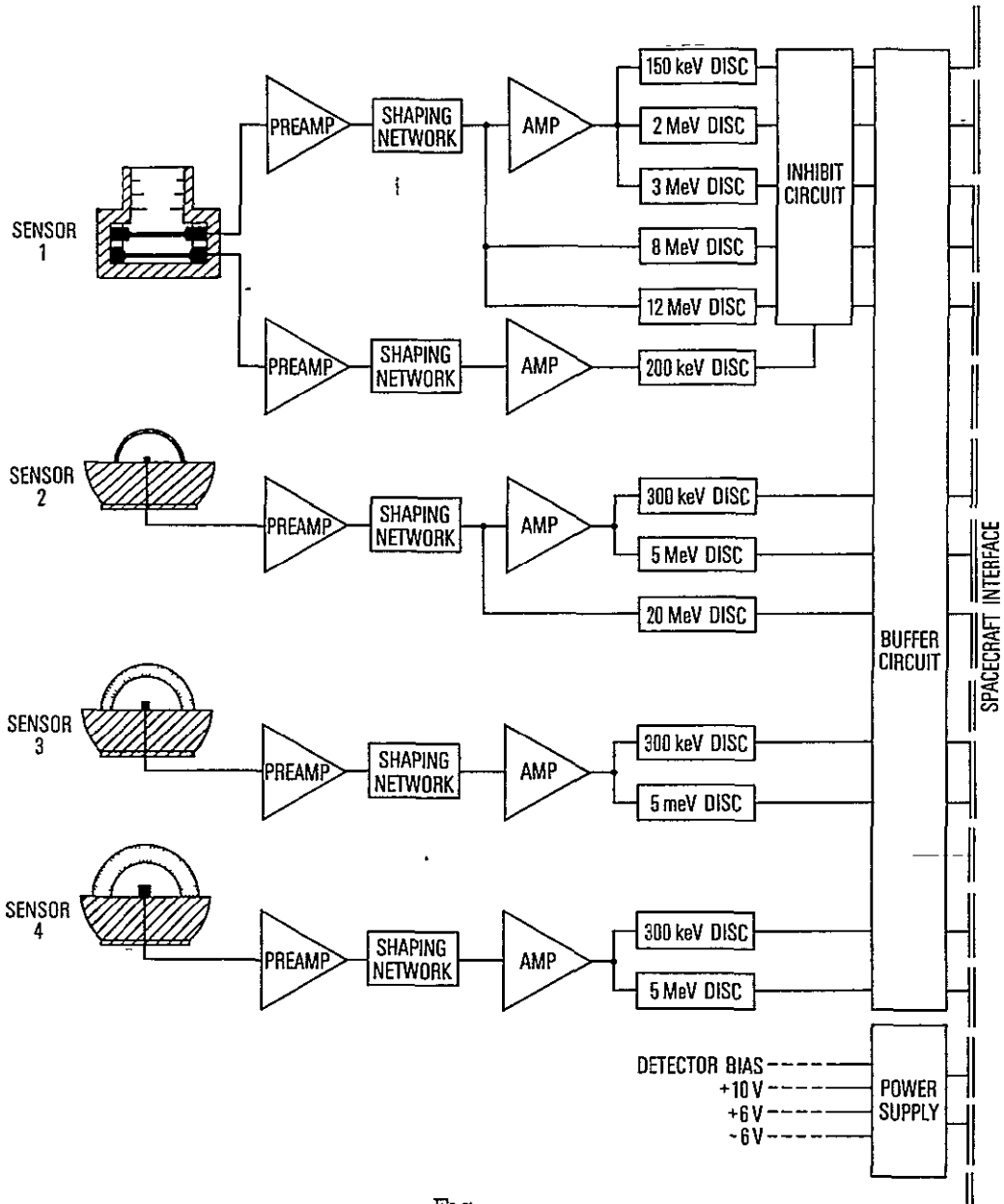
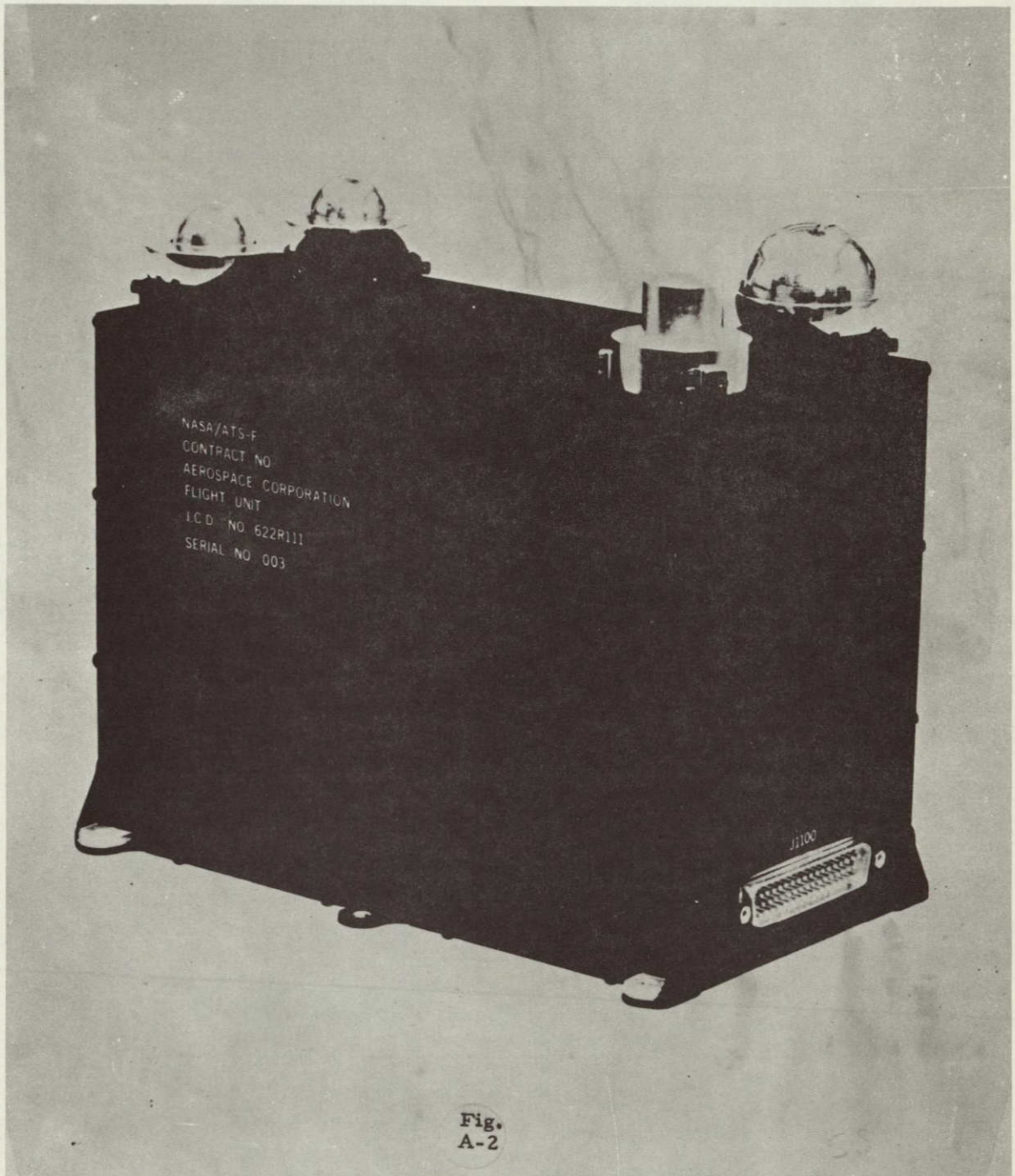

Fig.
A-1

ORIGINAL PAGE IS
OF POOR QUALITY



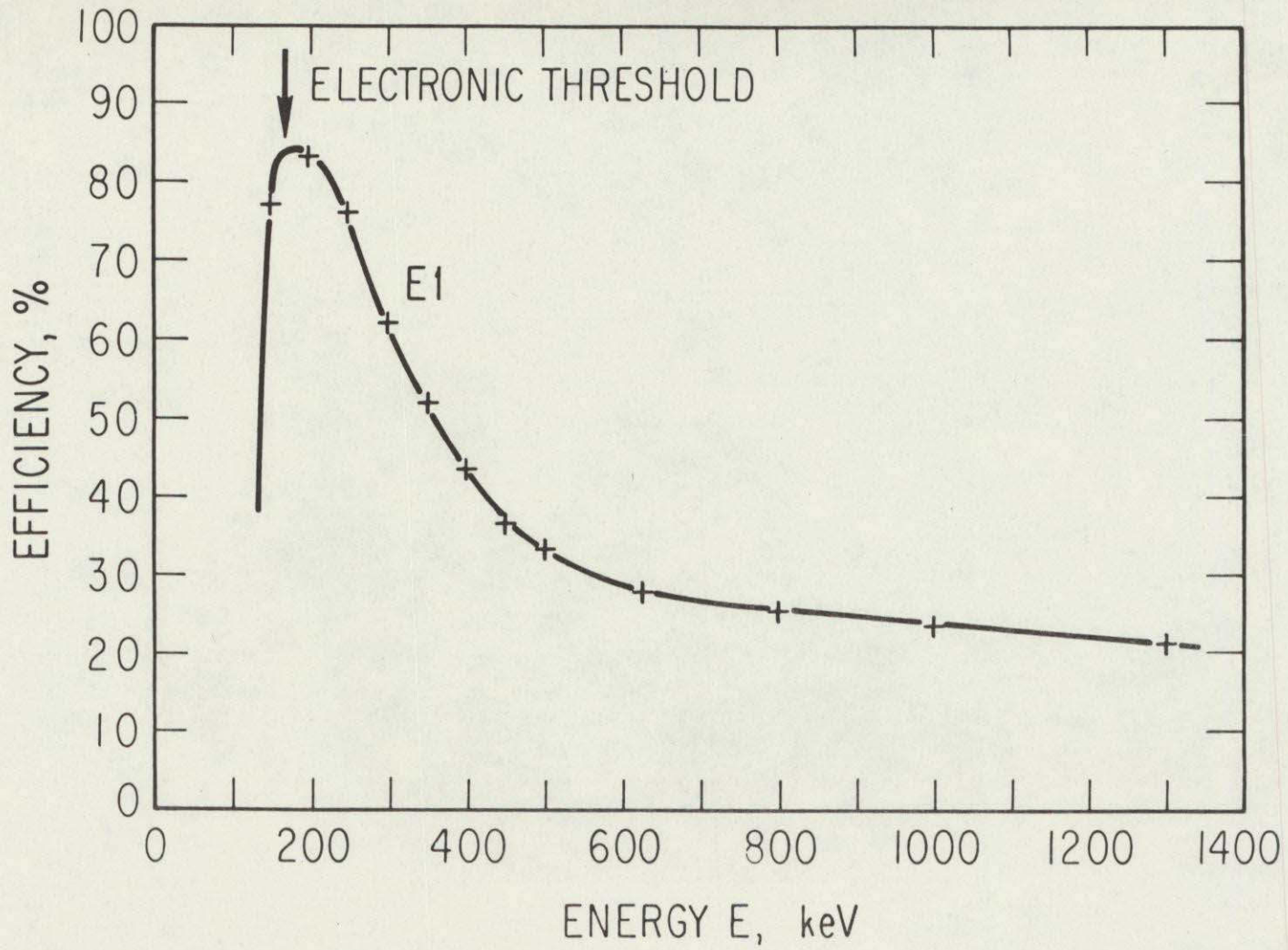

Fig.
A-3

DISTRIBUTION

Internal

J. B. Blake
G. W. King
E. B. Mayfield
R. X. Meyer
F. A. Morse

G. A. Paulikas
R. D. Rawcliffe
H. R. Rugge
H. H. Hilton
J. Frawley

External

NASA Goddard Space Flight Center
Greenbelt, MD 20771
Attn: L. Dubach, Code 601
J. P. Corrigan, Code 410
C. D. Wende, Code 410

NASA STIF
P. O. Box 8757
Baltimore/Washington Int. Airport
Baltimore, MD 21240

