

NASA Technical Memorandum 78643

Toughening of Graphite-Epoxy  
Composites by Interlaminar  
Perforated Mylar® Films

Wolf Elber

MARCH 1978

**NASA**

M78-12852

NASA-TM-10672

NASA Technical Memorandum 78643

Toughening of Graphite-Epoxy  
Composites by Interlaminar  
Perforated Mylar® Films

Wolf Elber  
*Langley Research Center  
Hampton, Virginia*

**NASA**

National Aeronautics  
and Space Administration

**Scientific and Technical  
Information Office**

1978

## SUMMARY

Fracture and notch-strength tests of graphite-epoxy composites have shown that unidirectional lay-ups generally exhibit longitudinal cracking before failure, whereas multidirectional lay-ups fail transversely with little longitudinal cracking. A simple qualitative analysis suggested that the higher matrix shear stresses in unidirectional materials cause the longitudinal cracking, and that this cracking is responsible for the higher toughness of unidirectional composites. In a series of comparative tests, the interlaminar strength of multidirectional composites was reduced by placing perforated Mylar<sup>1</sup> films between laminae; tests on notched and slotted specimens showed that the interlaminar films promoted delamination and longitudinal cracking near the notches and that, as a result, toughness, notch strength, and impact strength were substantially increased.

## INTRODUCTION

Although graphite-epoxy composites have a high strength-density ratio, they lack ductility and are more notch sensitive and more damage sensitive than many common metallic materials. Notch strength, fracture toughness, and impact resistance are of concern in primary structures, and several methods have been proposed previously to improve these properties. For example, hybrid composites use combinations of various fibers, such as fiber glass and graphite to increase their impact resistance and notch strength. In some hybrids (ref. 1) the lower modulus fibers (such as glass) and the graphite fibers are confined to separate laminae, whereas in others (ref. 2) they are mixed within each lamina. This hybridization also increases the fracture toughness of the composite. The softening-strip method uses lower modulus fibers in specific areas such as fastener rows to increase notch strength and toughness. In all these hybrids, the strength-density ratio is lower than that for graphite-epoxy alone.

The present paper reports on the development of a concept for improving the notch strength and toughness without resorting to lower modulus fibers. A comparison of the fracture modes of unidirectional composites and multidirectional composites indicated that the notch strength of multidirectional composites might be improved if local interlaminar shear failures could be induced before the main load-bearing fibers reached their ultimate strength. A method was conceived in which perforated Mylar film was laid between laminae to obtain a controlled interlaminar shear strength.

Results of fracture, notch-strength, and impact-strength tests are presented herein for graphite-epoxy composites with and without the Mylar film.

Commercial product names are used in this report to assure relevance. The use of these names does not constitute official endorsement, expressed or

---

<sup>1</sup>Mylar: Registered trademark of E. I. du Pont de Nemours & Co., Inc.

implied, of such products or manufacturers by the National Aeronautics and Space Administration.

## ANALYSIS

### General

In composite structural components, holes and slots interrupt the fibers. In unidirectional composites, only intralaminar shear stresses in the matrix material transfer loads from interrupted fibers to continuous fibers. In multidirectional composites, interlaminar shear stresses transfer loads from interrupted fibers in one lamina to continuous fibers in other laminae. The notch strength and fracture behavior of these two kinds of composites differ, and they will be examined separately.

### Unidirectional Composites

In notched unidirectional composites, matrix shear failures occur before the fibers are loaded to their ultimate strength. Thus, longitudinal cracks usually form along the edges of the notch before the net section of the test piece fails. This type of damage is considered matrix controlled.

Figure 1 shows the edge of a curved notch in a unidirectional composite. The arrows in the fibers indicate the force flow out of the interrupted fibers and into the matrix. The arrows in the matrix indicate the intralaminar shear flow which transfers force from the interrupted fibers to the continuous fibers. On the vertical section through the edge of the notch, all the force from the interrupted fibers must be carried by interlaminar shear in the matrix. In most epoxy-matrix composites these shear stresses are high enough to cause matrix shear failure before the tensile stress in the continuous fibers reaches the fiber tensile strength. The resulting longitudinal cracks move the load-transfer sites away from the edge of the notch and also limit the stress concentration in the continuous fibers.

### Multidirectional Composites

Most multidirectional graphite-epoxy composites fail by transverse cracking at net section stresses much lower than in unidirectional  $0^\circ$  composites. Much less matrix cracking occurs before the most highly stressed longitudinal fibers reach their ultimate strength and start a catastrophic failure. The onset of failure and the failure mode are considered to be fiber controlled.

Figure 2 shows the load path around a curved notch in a multidirectional composite. Only two locally important fiber directions are shown. Because of the stiffness of the fibers in the diagonal lamina, most of the forces from the interrupted longitudinal fibers flow through the interlaminar matrix into the diagonal fibers and then back into the uninterrupted longitudinal fibers. The matrix shear transfer occurs over the interlaminar interface, and because

of the greater extent of the interface transfer area, these shear stresses are lower than the maximum intralaminar shear stresses in the unidirectional composite.

The brittle transverse fracture of the multidirectional composites, then, occurs because the longitudinal fiber stresses reach the fiber strength before the matrix shear stresses reach the matrix shear strength. Comparatively little load redistribution occurs before total fracture.

The stresses around a notch could be redistributed by inducing early local delamination; two approaches seem promising. In the first, the local shear stresses between laminae of unlike orientation can be increased by grouping laminae of like orientation. A study of stacking-sequence effects in graphite-epoxy composites (ref. 3) has shown that this approach produces composites of higher toughness. In the second approach, the matrix shear strength can be reduced. This was done in the present study by partially separating the graphite-epoxy laminae with 0.014-mm-thick perforated Mylar film. The adjacent laminae were bonded through each perforation, but because of the poor Mylar-to-epoxy bond, the laminae were essentially unbonded elsewhere.

## EXPERIMENTAL PROGRAM

### Mylar Film Inlays

For this pilot study, Mylar film strips were perforated in one of two ways: with a computer-card punch or with a paper-tape punch. For the card punch, the Mylar film was taped to the back of a computer card, then the multiple-punch feature was used to punch every location of each card column. The film strips were limited in size to 160 by 75 mm. The open area of the film was approximately 40 percent. This type of perforated film is herein labeled film A.

A paper-tape punch was used similarly. The perforated film obtained was limited to 25 mm in width, but was unlimited in length. The average open area was 35 percent. This type of film is labeled film B.

### Materials and Tests

In this test series one material and one lay-up were tested. The material as supplied was 75-mm-wide, 0.14-mm-thick, preimpregnated tape of Thornel 300 graphite in Narmco 5208 epoxy resin.<sup>2</sup> The lay-up was (0°, ±45°, 0°, 90°), a symmetrical 10-ply lay-up which has 40 percent of the fibers oriented in the load direction. For the specimens with Mylar inlays, these inlays were located in every interlaminar space. The material was pressure cured between 150- by

---

<sup>2</sup>Thornel: Registered trademark of Union Carbide Corporation.

Narmco: Registered trademark of Narmco Materials Division, Whittaker Corporation.

300-mm plates at 465 K. All fracture and impact specimens were tested in a 1-MN-capacity servo-hydraulic testing machine. All tension and compression specimens were tested in a 100-kN-capacity servo-hydraulic testing machine.

### Fracture Specimens

Eight fracture specimens were produced and tested: four (1F, 2F, 3F, 4F) prepared with perforated film inlays and four (1P, 2P, 3P, 4P) prepared without perforated film inlays. The dimensions, types, and locations of the Mylar inlays are shown in figure 3. A nine-hole, 8-mm-bolt, symmetrical grip pattern suitable for the testing machine was used on all specimens. A crack-opening displacement gage was mounted on one side at the center line of the specimen. Four 2-mm-diameter attachment holes were drilled along the longitudinal center line for the gage-mounting blocks. A common loading rate of  $1 \text{ kN-s}^{-1}$  was used for all fracture specimens.

### Impact Specimens

Four unnotched specimens of type I (fig. 3) were prepared for impact testing with a projectile impact tester (ref. 4). Two of these specimens (5F and 6F) were fabricated with film A; two more specimens (5P and 6P) were fabricated without film. The specimens were loaded in uniaxial tension and, while under load, were impacted with a 12-mm-diameter aluminum ball at a speed of  $75 \text{ m-s}^{-1}$ .

### Notched Tension and Compression Specimens

Six specimens with film (7F to 12F) and six specimens without film (7P to 12P) were prepared for notched tension and compression tests. The configuration is shown in figure 4.

## RESULTS AND DISCUSSIONS

### Fracture Tests

Results of the fracture tests are listed in table I. Figure 5 contains plots of load as a function of crack-opening displacement for specimen 1F, the specimen of type I in figure 3 with film A inlay, and for specimen 1P, the companion specimen.

TABLE I.- FRACTURE TEST RESULTS

Specimen	Failure load, kN	Crack length, mm	$\delta_F/\delta_P$ (a)	$S_{net}/S_{ult}$
1F	55.5	37	5.0	0.64
2F	53.4	37	5.5	.61
3F	29.2	75	4.5	.51
4F	51.3	37	4.0	.59
1P	34.6	37		.40
2P	35.1	37		.40
3P	17.8	75		.31
4P	34.8	37		.40

<sup>a</sup>See figure 5. ( $\delta_F$  and  $\delta_P$  are crack-opening displacements for specimen F and specimen P;  $S_{net}$  and  $S_{ult}$  are the net section stress and the ultimate stress.)

For the companion specimen 1P, the load-displacement plot is linear to failure, as is typical for brittle materials. In contrast, the load-displacement plot for the specimen with the film inlays (1F) is highly non-linear. Moreover, specimen 1F sustained a 60-percent higher load and experienced 5 times the maximum crack-opening displacement of specimen 1P ( $\delta_F/\delta_P = 5.0$ ).

Figure 6(a) shows a portion of the fracture surface of specimen 2P. Typically, the fracture process was confined to a narrow region and involved the creation of a minimal amount of new surface. Figure 6(b) shows a portion of the fracture area of a specimen with the film inlays (specimen 2F). In contrast to the behavior of the companion specimen, the fracture created a much larger amount of new surface and involved extensive delamination. The perforation pattern is visible in the film where groups of longitudinal fibers were torn away from their neighboring diagonal fibers, which did not fracture but were extracted intact from the specimen during the fracture process.

Motion pictures of the fracture process, taken at 400 frames per second, revealed no visible surface changes before fracture in the specimen without Mylar; in addition, no fracture progression was observed at this filming speed, an indication that crack-growth rates were extremely high.

In the specimens with film inlays, longitudinal cracks first appeared in the surface layers at about 70 percent of the maximum load and grew to about 20 mm just before fracture. The final fracture process covered less than three frames (approximately 0.01 s), too few for an analysis of the sequence of events.

For specimen 1F the average net section stress at failure was 350 MPa, or 64 percent of the nominal handbook value for the tensile strength ( $S_{ult} = 551$  MPa). If, in the debonded stage, all the load were carried by the longitudinal fibers, the average net section stress at failure on these fibers would be 877 MPa, or 64 percent of the ultimate unidirectional strength of the 0° ply (1378 MPa). This indicates that despite the significant debonding, the material still had some notch sensitivity. Further testing would be required to assess the relative contributions of the interlaminar and intralaminar shears to the remaining notch sensitivity.

The fracture results for specimens 2F, 3F, and 4F and their companion specimens 2P, 3P, and 4P are summarized in table I. Essentially, all the film-inlaid specimens behaved as specimen 1F, with the onset of nonlinear behavior taking place at approximately two-thirds of their failure loads, that is, near the failure-load levels of the companion specimens. The total crack-opening displacements  $\delta_F$  were always about 5 times those of the control specimens at fracture  $\delta_P$ . Specimen 4F showed the smallest crack-opening displacement and the lowest toughness of the film-inlaid specimens, probably because the film inlay was too narrow to promote the development of a large debond zone.

#### Impact Tests

The results of the impact tests are listed in table II. Specimen 5F survived the impact but was left with a visible delamination zone about 20 mm in diameter centered around the impact point. The delamination extended through the full thickness of the specimen.

TABLE II.- IMPACT TEST RESULTS

Specimen	Prestress, MPa	Result
5F	313	Survived
6F	375	Survived
5P	313	Failed
6P	250	Failed

Specimen 6F, loaded at a 20-percent higher prestress than specimen 5F, also survived. A visible delamination zone about 50 mm in diameter was produced. In this case the projectile passed through the specimen, but no recognizable hole was left in the damage zone. The damage apparently involved complete shattering of the matrix material, because the thickness of the specimen had increased by about 50 percent near the impact point, and the damaged material had a spongy feel.



Specimen 5P, the specimen without Mylar, fractured explosively under the impact. No visible damage zone was found along the fracture line. Specimen 6P, which was impacted at a 20-percent lower prestress, also fractured, though less explosively than specimen 5P - a sign that the lower stress level was probably close to the threshold for failure under the given test conditions. The impact left a visible indentation in the center of the fracture plane.

Therefore, for the particular impact and the specimen configuration, the failure threshold tensile stress is greater than 375 MPa for the material with the Mylar film inlay and less than 250 MPa for the material without the Mylar.

#### Notched Tension and Compression Tests

Tension tests were performed on three specimens of film-toughened material (7F, 8F, and 9F) and on three specimens without Mylar film (7P, 8P, and 9P). Table III shows the results of these tests. The average tensile strength of the notched film-toughened specimens was 45 percent higher than that for the control specimens. A similarity in the modes of failure of both groups was that the 45° laminae were pulled out of the laminate. Apparently, the delamination zone extended over the entire width of the specimen. In the control specimen, the 0° laminae broke in a continuous line from the notch to the edge, whereas in the film-toughened specimens, the breaks in the 0° laminae occurred in a more random fashion.

TABLE III.- TENSION TEST RESULTS

Specimen	Failure stress, MPa	$S_{net}/S_{ult}$ (a)
7F	330	0.60
8F	308	.56
9F	317	.58
7P	210	.38
8P	235	.43
9P	215	.39

$a_{s_{net}}$  is net section stress;  $S_{ult}$ , ultimate stress, or strength.

Compression tests were performed on three specimens of film-toughened material (10F, 11F, and 12F) and on three specimens without the Mylar film (10P, 11P, and 12P). Table IV shows the results of these tests.

TABLE IV.- COMPRESSION TEST RESULTS

Specimen	Compressive strength, MPa
10F	255
11F	232
12F	260
10P	241
11P	230
12P	245

The failure modes were difficult to analyze because of the crushing damage. In at least two specimens (10F and 11P) some buckling of the 0° surface laminae was observed before the full compressive strength was reached. The compressive strengths of the film-toughened specimens and the control specimens were essentially the same.

#### CONCLUDING REMARKS

A qualitative analysis of unidirectional and multidirectional graphite-epoxy composites has suggested that high matrix shear stresses in the unidirectional composite cause longitudinal cracking and that, as a result, unidirectional composites have relatively high notch strength and toughness. In multidirectional composites, the shear stresses in the matrix are lower, so that failure is more likely to initiate in the longitudinal fibers at the edge of the notch. Therefore, the multidirectional composites have lower notch strengths and are brittle.

Tests of multidirectional laminates with intentionally reduced interlaminar strengths have shown that toughness, tensile notch strength, and impact strength were enhanced by reducing the interlaminar strength. In these tests, perforated Mylar films were used to weaken the interlaminar bond.

Langley Research Center  
 National Aeronautics and Space Administration  
 Hampton, VA 23665  
 February 15, 1978

## REFERENCES

1. Chamis, C. C.; Hanson, M. P.; and Serafini, T. T.: Impact Resistance of Unidirectional Fiber Composites. Composite Materials: Testing and Design (Second Conference), ASTM Spec. Tech. Publ. 497, 1972, pp. 324-349.
2. Zweben, Carl H.: Hybrid Fiber Composite Materials. Proceedings of the 1975 International Conference on Composite Materials, Volume 1. Metallurgical Society Conferences, E. Scala, E. Anderson, I. Toth, and B. R. Noton, eds., Metallurgical Soc. AIME, 1975, pp. 345-367.
3. Mandell, John F.; Wang, Su-Su; and McGarry, Frederick J.: The Extension of Crack Tip Damage Zones in Fiber Reinforced Plastic Laminates. J. Compos. Mater., vol. 9, July 1975, pp. 266-287.
4. Rhodes, Marvin D.; Williams, Jerry G.; and Starnes, James H., Jr.: Effect of Low-Velocity Impact Damage on the Compressive Strength of Graphite-Epoxy Hat-Stiffened Panels. NASA TN D-8411, 1977.

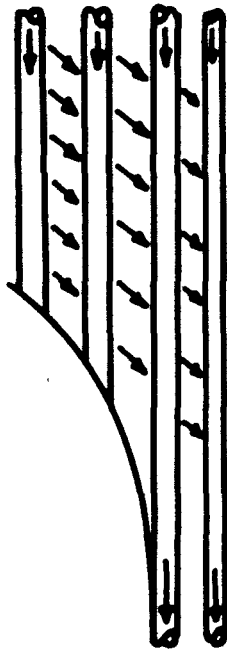

Figure 1.- Force flow for a unidirectional composite.

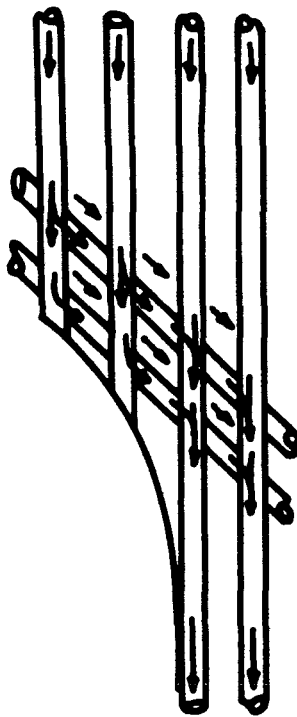

Figure 2.- Force flow for a multidirectional composite.

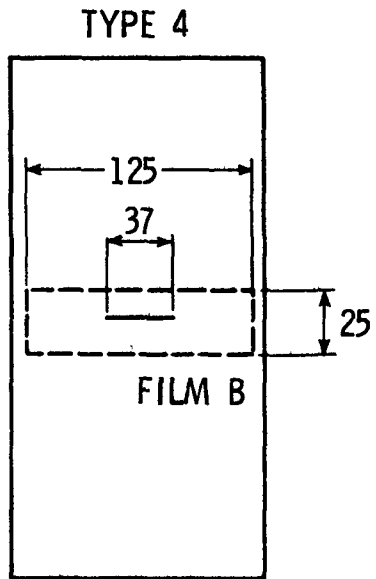
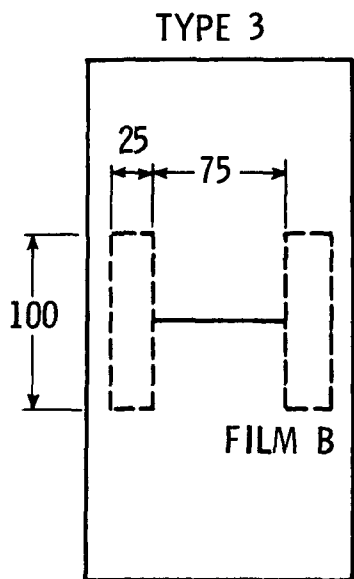
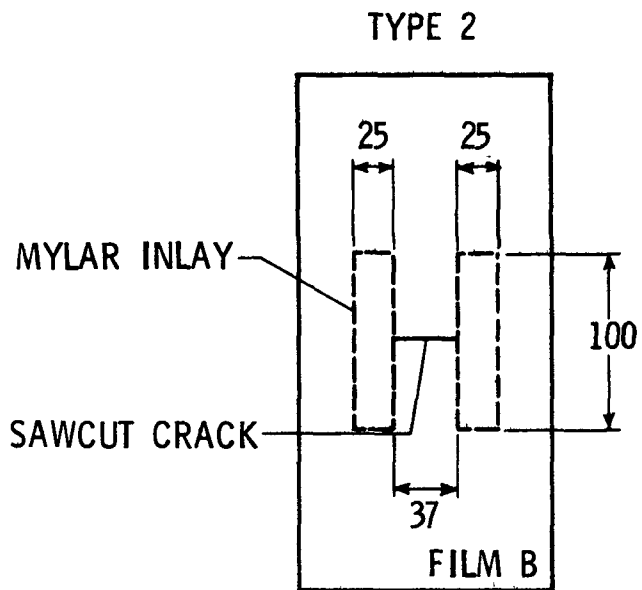
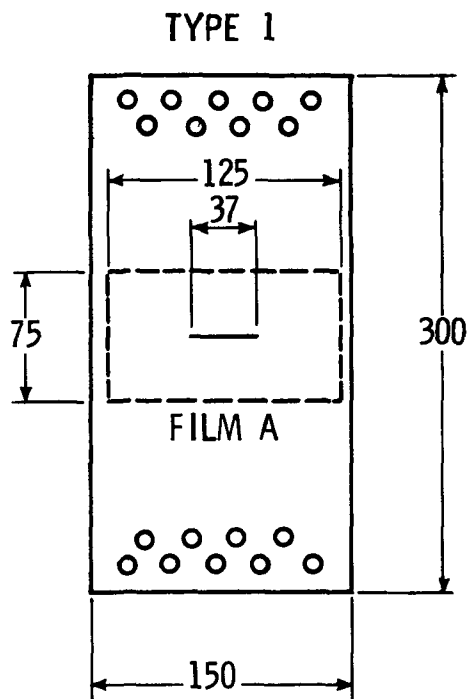

Figure 3.- Fracture specimen configurations.  
 (All dimensions are in millimeters.)

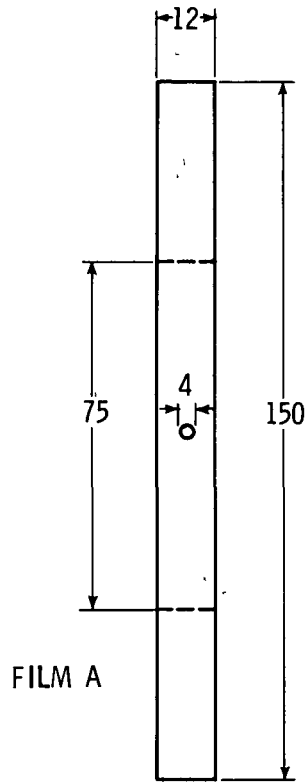

Figure 4.- Notched tension and compression specimens.  
(All dimensions are in millimeters.)

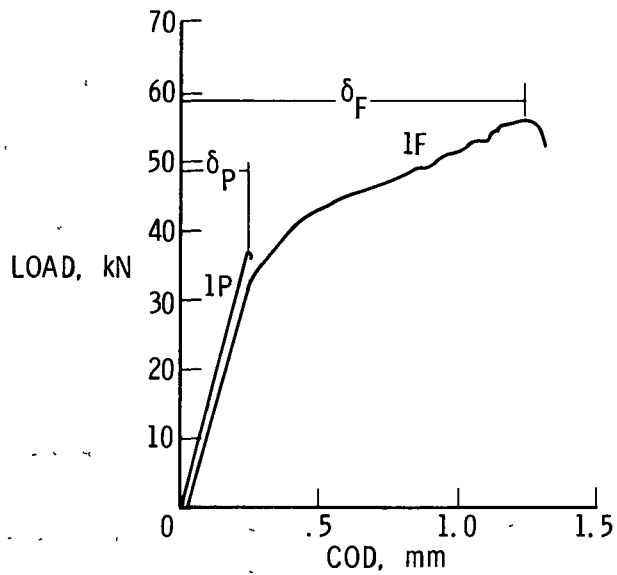
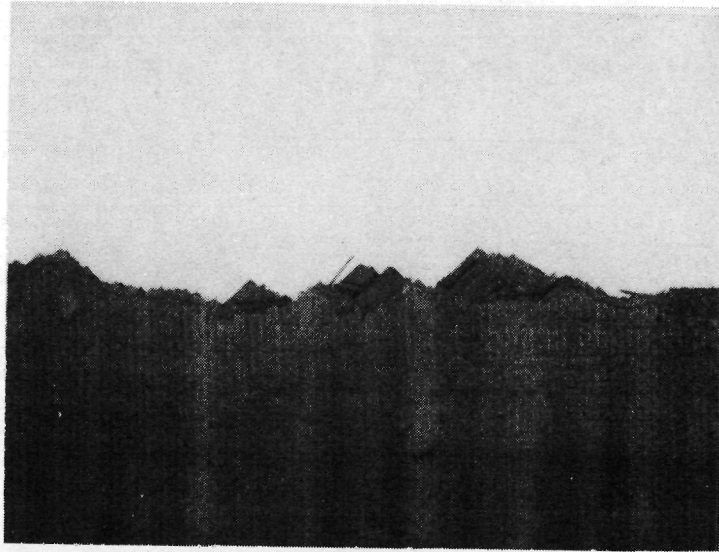
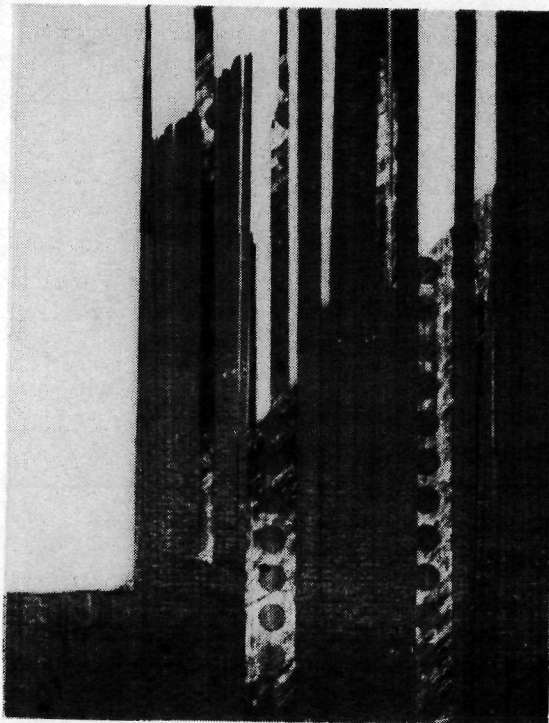

Figure 5.- Relation between load and crack-opening displacement  
for specimens 1F and 1P.



(a) Plain specimen (2P).



(b) Mylar-inlaid specimen (2F).

L-78-20

Figure 6.- Fracture surfaces of graphite-epoxy fracture specimens.

1 Report No NASA TM-78643		2 Government Accession No		3 Recipient's Catalog No	
4 Title and Subtitle TOUGHENING OF GRAPHITE-EPOXY COMPOSITES BY INTERLAMINAR PERFORATED MYLAR <sup>®</sup> FILMS				5 Report Date March 1978	
				6 Performing Organization Code	
7 Author(s) Wolf Elber				8 Performing Organization Report No L-11462	
9 Performing Organization Name and Address NASA Langley Research Center Hampton, VA 23665				10 Work Unit No 505-02-31-01	
				11 Contract or Grant No	
12 Sponsoring Agency Name and Address National Aeronautics and Space Administration Washington, DC 20546				13 Type of Report and Period Covered Technical Memorandum	
				14 Sponsoring Agency Code	
15 Supplementary Notes					
16 Abstract  Fracture and notch-strength tests of graphite-epoxy composites have shown that unidirectional lay-ups generally exhibit longitudinal cracking before failure, whereas multidirectional lay-ups fail transversely with little longitudinal cracking. A simple qualitative analysis suggested that the higher matrix shear stresses in unidirectional materials cause the longitudinal cracking, and that this cracking is responsible for the higher toughness of unidirectional composites. In a series of comparative tests, the interlaminar strength of multidirectional composites was reduced by placing perforated Mylar films between laminae, tests on notched and slotted specimens showed that the interlaminar films promoted delamination and longitudinal cracking near the notches and that, as a result, toughness, notch strength, and impact strength were substantially increased.					
17 Key Words (Suggested by Author(s)) Composites Fracture toughness Notch strength Impact strength			18 Distribution Statement Unclassified - Unlimited  Subject Category 27		
19 Security Classif (of this report) Unclassified		20 Security Classif (of this page) Unclassified		21 No of Pages 13	22 Price* \$4.00



National Aeronautics and  
Space Administration

SPECIAL FOURTH CLASS MAIL  
BOOK

Postage and Fees Paid  
National Aeronautics and  
Space Administration  
NASA-451



Washington, D.C.  
20546

Official Business  
Penalty for Private Use, \$300

3 2 1U,C, 030478 S90844HU  
MCDONNELL DOUGLAS CORP  
ATTN: PUBLICATIONS GROUP PR 15246-A  
P O BOX 516  
ST LOUIS MO 63166

**NASA**

POSTMASTER · If Undeliverable (Section 158  
Postal Manual) Do Not Return

---

*Ferry Bevel 247/32/2/20*  
*247/32/2/20*