

MADISON 15671

SCPI



(NASA-CR-156717)	USER MANUAL AND PROGRAMMER	N78-20167
REFERENCE MANUAL FOR THE ATIS-6 NAVIGATION		
MODEL AOIPS AND ECIDAS VERSIONS, PART 2		
Final Report, period ending 31 Dec. 1977		
(Wisconsin Univ.) 145 p HC A07/MF A01	G3/15	Unclas 11854



A REPORT

from the space science and engineering center
the university of wisconsin-madison
madison, wisconsin

USER MANUAL AND PROGRAMMER REFERENCE MANUAL
FOR THE ATS-6 NAVIGATION MODEL
AOIPS AND MCIDAS VERSIONS

Part II of Final Report for Period Ending 31 December 1977

Contract Number NAS5-20974

For
National Aeronautics and Space Administration
Goddard Space Flight Center
Greenbelt, Maryland 20771

By
G. C. Chatters
W. W. Kuhlow

University of Wisconsin
Space Science and Engineering Center
1225 West Dayton Street
Madison, WI 53706



December 1977

Table of Contents

	<u>Page</u>
Preface	i
I. The ATS-6 Navigation Problem	I-1
II. Using the ATS-6 Navigation System	II-1
III. Computer Program Command Formats	III-1
A. AOIPS Version of November 1977	III-1
B. McIDAS Version of November 1977	III-5
IV. Software Internal Description	IV-1
A. Description of Procedures Used by Main Programs	IV-2
B. Entries in Common Block NAVCOM	IV-5
C. Subroutine Function Descriptions	IV-8
References	
Appendix A. Basic Navigation Model Applied to ATS-6 Image Data Base	A-1
Appendix B. Analysis of Method Which Determines ATS-6 SSP Image Coordinate Displacements Between Successive Images Resulting From Attitude Changes	B-1
Appendix C. Analysis of Algorithm Which Accounts for Relative Attitude Changes in Successive ATS-6 Data Images Using Earth-Edge Shift Measurements	C-1
Appendix D. Method of Obtaining Alternate Scan Alignment Curves	D-1
Appendix E. Source Code Listings of Programs and Subroutines	E-1

Preface

This user and programmer reference manual together with the Progress Report for the Period Ending 31 October 1977 constitute the Final Report for Contract NAS5-20974. This manual describes the computer programs developed to implement the ATS-6 navigation model on both the AOIPS at GSFC and the McIDAS at SSEC. The above mentioned progress report describes the theory of the navigation model and the results obtained with it. Some of the Appendices of that report have been updated and included here.

Acknowledgements

As with most projects of this size, many people have contributed their efforts. At the Space Science and Engineering Center, Tom Haig helped initiate the project, Ralph Dedecker and Bruce Sawyer worked on the early stages of programming. Dennis Phillips helped with the orbit and attitude models. Dave Martin helped evaluate the wind fields produced by cloud tracking on the ATS-6 images. Rosanne Koehler typed this and previous reports.

At the Goddard Space Flight Center, in addition to the contract monitor, R. K. Squires, the project received considerable help from the AOIPS staff, especially C. T. Mottershead of CSC.

I. The ATS-6 Navigation Problem

A. Introduction-Objective

If a satellite image or sequence of images of the earth is to be useful for quantitative measurement, it is necessary to be able to determine the earth location (latitude and longitude) that corresponds to any given picture element (line and element) in that image or sequence of images. Development of a navigation system for a given satellite involves two procedures: 1) Defining an algorithm for converting a satellite picture element location to earth location and vice versa; 2) Defining a procedure for measuring the set of constants needed by the algorithm in 1) above. Previous progress reports for this project describe how the ATS-6 navigation model was developed. This user manual briefly describes the current version of the navigation model (this section) and how to use the computer programs developed for it (following sections).

In the process of developing a navigation model for satellite images we must establish criteria of validity for the resulting model. Since there is no way to precisely relate the image location to other satellite sensors, the criteria of validity must be referenced to some measurement derived from the image itself. For this work, two tests were used. First, the line and element position of identifiable earth points (landmarks) was measured and compared to the values predicted by the navigation model. Ideally these should always differ by less than one pixel. In general, this navigation model is capable of predicting positions within an error of the order of one pixel. Second, a set of cloud

tracer winds was derived from a three-image time sequence. These winds were compared to measurements made on the same clouds in SMS-1 images from approximately the same time. Winds, averaged over approximately one hour, from each of the two satellites showed agreement on the order of one meter per second. In the following sections we describe the model used in making these measurements.

B. Nature of the Problem

A three-axis stabilized satellite contains an attitude measuring and correcting system which attempts to keep the satellite and its camera pointed at some selected point. For ATS-6 the camera is generally aimed at the point on the earth's equator which is closest to the subsatellite point. In order to keep the satellite camera pointing in its desired direction within its required range of accuracy, the satellite's attitude may be changed by significant and unpredictable amounts about all three axes several times during the scanning of an image. If wind speeds are to be measured accurately, the attitude changes must be measured and accounted for.

In addition to attitude changes of the satellite, we find that we must also account for image distortions caused by the scanning mechanism. We refer to this problem as mirror-scan nonlinearity. Ideally the images would be generated by sampling at equal-angle intervals (angular position a linear function of picture element number) as the camera's mirror scans across the earth. However, the ATS-6 camera scans in both left to right and right to left directions

and therefore the camera's scanning mirror must change direction and accelerate for each scan. Two resulting effects are evident in the images: scan lines of opposite direction are offset by 7 to 11 pixels and each scan line varies from equal-angle sampling by 2 or 3 pixels maximum over a 200 pixel range.

C. The Solutions to the Problems

In this section we describe the methods currently used for attitude determination and for correcting mirror-scan nonlinearity in ATS-6.

The satellite has attitude sensors and data from these sensors are recorded on magnetic tape along with the image data. Unfortunately, we found that these attitude telemetry data did not accurately reflect changes in satellite attitude as seen in the images. As a result we developed a method to correct for attitude changes using the images themselves. This is the earth edge displacement technique described in Section III of reference 3. These earth edge displacement measurements enable us to compute the changes in attitude with time. We must also compute a reference attitude, usually the mean attitude for the first image in a sequence of three to be studied. This reference attitude is computed from landmark measurements; the technique is described in references 1 and 2.

The problem of mirror-scan nonlinearity cannot be solved completely, but a correction scheme adequate for our purpose of cloud tracking has been developed. Ideally, we would like to define some reference coordinate system to use in converting the images to equal-angle sampling. Unfortunately, we have no way

to define such a coordinate system which would be independent of the images. Thus, we use one scan direction (odd numbered scans) as a reference and shift scans of the opposite direction to match. This method corrects the alternate scan offset but leaves an uncorrected nonlinearity of up to two to three pixels at some points in the image. This error is reasonably constant from one image to the next and is small enough and varies slowly enough that the images may still be used for cloud tracking.

II. Using the ATS-6 Navigation System

A. Introduction

This section gives a general discussion of the use of the ATS-6 image correction and navigation software. For specific commands and data inputs to the various programs see Section III. The general organization of the main programs is indicated in Fig. II.1.

B. Image Correction

The alternate scan element shift function $\Delta E(E)$ which is used to correct for mirror-scan offsets (Appendix D) is computed from infrared image data. The program OFSTG computes values of ΔE and a weighting function at points at equal intervals across the image. This procedure is described in detail in Appendix D. Since the image is not viewed before running this program it is not known if some of the computed offset points will be computed for locations off the earth. Some offset points will be averages of computations from data entirely on the earth, some entirely off the earth and some mixed. Because the brightness off the earth is almost uniform, the weighting factor, which is the brightness range in the line segment used in the correlation computation, will cause the off-earth points to have negligible effect on the averaged offset. Data points for correlations done entirely from off-earth data must be eliminated from the curve-fitting process. To do this the user must scan through the listing of offset and weight values from OFSTG. There is a fairly sharp discontinuity at both earth edges. The element location of these edges are then input to program OFSTF.

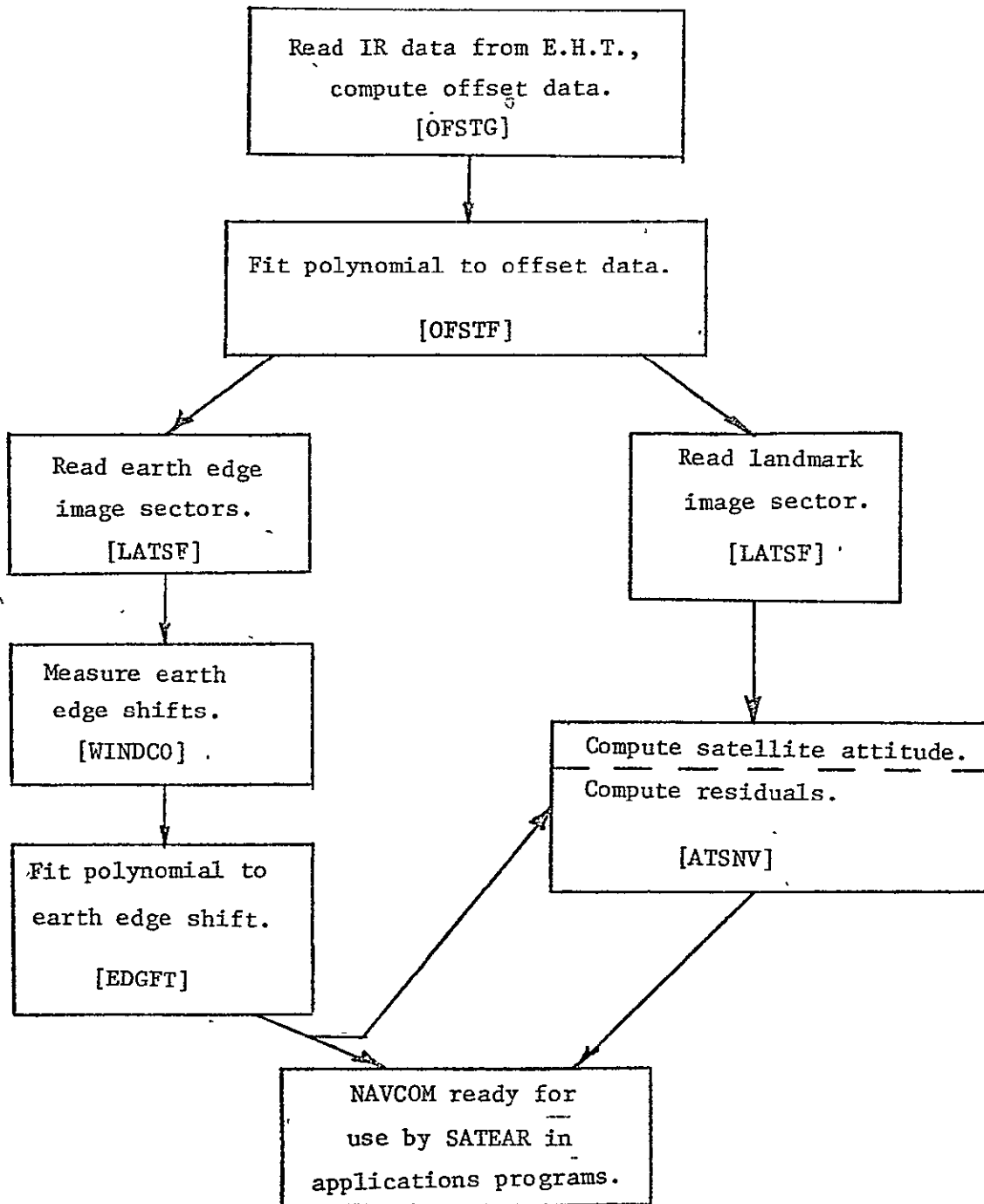

Figure II.1. General organization of ATS-6 image correction and navigation software. Names of corresponding computer programs in brackets.

The offset data points generated are not only discontinuous but also very noisy. Therefore we fit a smoothing and interpolating polynomial to the data points. This is done by program OFSTF. As stated above OFSTF must have the limits of valid data. The program OFSTF sets up arrays for subroutines APCH and APFS. These least-squares polynomial fitting subroutines are standard procedures from the IBM Scientific Subroutine Package (SSP).

Once the alternate scan correction polynomial has been determined, program LATSF may be used to read image segments from the tapes. This program requires input data specifying the date and time of the image for image identifier entries. This program reads a standard size image area which is 512 lines by 512 elements on AOIPS or 500 lines by 672 elements on McIDAS. The location of this segment with respect to the whole image is specified as input data in terms of line and element of the upper left corner of the image segment.

It should be noted here that this alternate scan correction method only shifts data from one scan direction to match that of the other. It does not correct the data to true equal-angle sampling.

C. Attitude Determination

The initial satellite attitude is determined from landmarks and the satellite's orbit. The attitude computation is done using several widely spaced landmarks on the first image (t_1) of the sequence to be used. A minimum of three landmark areas should be used. One or, preferably, more landmark points may be measured in each area. Landmarks should also be measured for other images in

the sequence to serve as a check on the computations and on the stability of the attitude.

Attitude changes from one image to the next are determined from earth edge displacement measurements. These displacements are measured using the regular AOIPS or McIDAS cloud tracking program (WINDCO). For this procedure a pair of images at the earth edge are loaded (say t_1 and t_2). Then the wind tracking procedure using a correlation tracking metric is used to track the displacements of the edges. The line direction lag size is set to zero so that the correlation peak search is done by moving the target grid only horizontally (i.e. in element direction) within the search grid. This measurement is made approximately every 5 to 10 lines along the edge. It need only be done for the same range of lines as is covered by the area to be used for cloud tracking; but must be done for both edges. As in the case of the alternate scan data, these measurements form a discontinuous and slightly noisy function. The program EDGFT is used to fit a set of Chebyshev polynomials to the data points for each edge. The coefficients, number of coefficients, scaling factors and valid range of use in terms of time of day at a given line are stored in common block NAVCOM. Reference 3, especially Section III, gives more of a discussion of the earth edge correction techniques.

D. Measuring Cloud Tracer Winds

Once the attitude and earth edge displacement polynomial coefficients have been computed and placed in common block NAVCOM along with the orbit and frame constants, the coordinate transform functions

are ready for use in cloud tracking. The functions available are SE for satellite image coordinate (line, element) to earth coordinate (latitude, longitude) transformations and ES for the inverse. For compatibility with SMS systems a subroutine SATEAR, which links to ES and SE is supplied.

III. Program Command Format

This section describes the command formats for using the ATS-6 navigation programs. There are two versions, one on the AOIPS and one on the McIDAS. Part A covers the use of the AOIPS version. AOIPS uses a prompting system; the appropriate responses to each of the prompting requests are explained. McIDAS uses a command input system; the command sequence and input parameters are explained.

A. AOIPS Version of November 1977

There are currently six main programs plus the main menu driver for ATS-6 processing on AOIPS. These are set up to work with the METPAK driver MET2 or Terminal 2. The system is started up by mounting the METPAK disk on RD0:, then installing the tasks. The main menu driver expects them to have a name ending in 2 (e.g. LATSF2). The installation command file RD0:[1,162]ATSINS.CMD is available. Operation must be initiated by first running METPAK to restore the global common. Once the common has been restored, the EXIT option is taken and the ATS-6 menu driver ATSF2 is initiated (i.e. RUN DB0:[350,62]ATSF2). The system is now ready to run.

A. AOIPS Version of November 1977

1. A6INT - Initialize COMMON/NAVCOM/

Initiate by requesting option: 1 - INITIALIZE NAVCOM
on the ATS-6 PROCESSING menu.

Input request:

NAVCOM TO BE PRINTED? (1 = YES, DEFAULT = NO)

Response: If a 1 is entered, the updated contents of
COMMON/NAVCOM/ will be output to the line printer just
before A6INT exits. Otherwise, not.

Input request:

ENTER DAY NUMBER

Response: Enter the Julian day number (1-365) of the data
to be worked with. Year is assumed to be 1974.

Input request:

ENTER 3 PICTURE START TIMES - HHMMSS

Response: Enter the picture start time, to nearest second,
for the three images to be worked with. As currently set
up COMMON/NAVCOM/ can only hold enough coefficients for
earth edge correction for three image times.

Input request:

ENTER FIRST ORBIT POSITION: T(HHMMSS), X, Y, Z (KM)

Response: Enter a satellite orbit position vector as read
from orbit data on the experimenter history tape. T is the
time of the position in packed integer format (hours, minutes,
seconds), X, Y, Z are the location in the earth inertial
co-ordinate system in floating point kilometers.

Input request:

ENTER SECOND ORBIT POSITION: T(HHMMSS), X, Y, Z (KM)

Response: Same as above for a second satellite orbit position.

Default: Except as noted, the default response causes a return to the ATS-6 processing menu.

Program output: A6INT will enter values into COMMON/NAVCOM/ which is part of the saved global common.

2. OFSTG - Generate alternate scan offset data points.

Initiate OFSTG by requesting option:

2 - GENERATE ELEMENT OFFSET DATA FROM E.H.T.

from the ATS-6 PROCESSING MENU.

Set up: Mount an ATS-6 Experimenter History Tape on tape drive MMØ or MMI.

Input request:

MOUNT TAPE. ENTER DRIVE NUMBER.

Response: After mounting the tape, enter a Ø or 1 for MMØ or MMI respectively.

Default: The default is tape unit MMØ.

Program output: OFSTG will print a table of element numbers, offsets and weights on the line printer. These same values are stored in global common in COMMON/BUFFER/ and COMMON/BUFFL/ for use by program OFSTF.

Note: This program is a heavy user of CPU cycles.

3. OFSTF - Fit a set of Chebyshev polynomials to the data points generated by program OFSTG.

This program is automatically initiated at the end of program OFSTG. It may also be initiated by requesting option 3 - CURVE FIT TO OFFSET DATA.

Input request:

ENTER LEFT, RIGHT ELEMENTS FROM PRINTER LISTING.

Response: The printer output of offset values should show a fairly continuous variation in the mid-portion of the element

range with a noticeable discontinuity near each end. Enter the element number of the points at each end of the continuous midsection of the data. For example, for day 74195 164223Z data these values were 180 and 2270.

Default: On default entry the system returns to the ATS-6 PROCESSING menu.

Program output: The program fits a set of Chebyshev polynomials to the data points and store the coefficients in the global COMMON/NAVCOM/.

4. LATSF - Read image segments from ATS-6 experimenter history tapes.

Initiate by requesting option 4 - READ IMAGE SEGMENT FROM E.H.T. The programs A6INT, OFSTG, and OFSTF should have been run to set up COMMON/NAVCOM/ entries. Mount the E.H.T. on tape drive MMØ or MML.

Input request:

ENTER PICTURE TIME (HHMMSS)

Response: Enter the picture start time in packed hours, minutes, seconds format. This must be exactly the same as one of the three entries made while initializing NAVCOM. (See A6INT above.)

Input request:

ENTER START LINE AND ELEMENT

Response: Enter the image coordinates for the upper left hand corner of the desired image.

Input request:

ENTER ZOOM AREA (1-7)

Response: Select a number from 1 to 7 to designate this region of the earth. Use the same number for a given area for all three picture times.

Input request:

ENTER TAPE UNIT (0,1)

Response: Enter 0 or 1 according to which drive the tape is mounted on (MM0 or MML).

Default: If a default entry is made, the system returns to the ATS-6 PROCESSING menu.

Program output: This program loads 512 x 512 element image segments onto digital disk files. Both visible and infrared data are loaded for each request.

5. EDGFT - Fit a set of Chebyshev polynomials to earth edge measurements stored in the wind file.

Initiate this program by requesting option 5 - CURVE FIT TO EARTH EDGE DATA. Earth edge measurements should be stored in the wind file. There are no requests for input.

Program output: This program fits a set of Chebyshev polynomials to left and right earth edge data. The coefficients are stored in COMMON/NAVCOM/.

6. ATSNV - Compute a nominal attitude from landmarks.

Initiate this program by requesting option 6 - RUN NAVIGATION. Landmark measurements from ATS-6 should be stored on the landmark file. (Currently this program reads test landmarks from the file DB0:[350,62]A6LMKS.DAT., however, the program should be modified before general use.) There is no request for keyed in data.

Program output: This program computes yaw, pitch and roll values and stores them in global COMMON/NAVCOM/. In addition, these values are displayed on the operator terminal. The landmarks and computed residuals are output to the line printer.

B. McIDAS Version of November 1977

1. Set up and initializing COMMON/NAVCOM/.

The current ATS-6 navigation system uses the files OFFSTD and ATSCOM. These two twenty sector files should be created before attempting to use the McIDAS ATS-6 navigation.

The navigation program should be run to initialize COMMON/NAVCOM/ and to set the three picture start times used for earth edge corrections. To zero NAVCOM enter:

```
AN 0 0 0 0 NEW
```

To set picture start times enter:

```
AN 0 0 0 0 HHMMSS1 HHMMSS2 HHMMSS3
```

Orbit, frame geometry and scan period are to be stored in the McIDAS navigation file using standard McIDAS commands DQ, DS and ON. Entries are:

```
DS SSYDDDD scan period (μsec)
(e.g. DS 1474195 1200000)
```

```
DQ FIRST SSYDDDD HHMMSS X1 Y1 Z1 (decameters)
DQ SECOND SSYDDDD HHMMSS X2 Y2 Z2 (decameters)
(e.g. DQ FIRST 1474195 175531 -1198560 4041970 -43760)
      DQ SECOND 1474195 164223 133380 4214050 -5950)
```

```
ON SSYDDDD Line-angle Total-lines Element-angle Total-elements
Angle are in +DDMMSS format
(e.g. ON 1474195 195512 2400 200412 2400)
```

2. Generate alternate scan offset data points.

Set-up: Mount an ATS-6 experimenter history tape on a tape drive. Enter: MT 14 0.

Running program: Enter the two letter keyin (currently GC). There are no parameters.

Program output: This program will print a table of element numbers, offsets and weights on the line printer. These same values are stored in the file OFFSTD.

3. Fit a set of Chebyshev polynomials to the data points stored in file OFFSTD.

Set-up: The program to generate the data points must have been run first (see 2 above).

Running program: Enter the two letter keyin (currently GC). The parameters are the left and right ends of the valid element range. These values are determined from the printer listing of offset values generated in 2 above.

Program output: This program does a least squares fit of a set of Chebyshev polynomials to the alternate scan data. The coefficients are stored in COMMON/NAVCOM/.

4. Read image segments from ATS-6 experimenter history tapes into digital areas.

Set-up: Mount tape. COMMON/NAVCOM/ should have been set up by previous programs.

Running program: Enter the two letter keyin and parameters:
BK SSYDDDD HHMMSS Area Line Element

Program output: This program loads a visible, infrared or combined area onto digital disk areas. Only standard size areas (500 x 672) may be used.

5. Fit a set of Chebyshev polynomials to earth edge measurements stored in the wind file.

Set-up: Use WINDCO with image coordinates (WC I) and line lag size zero (LS 0 X) to measure earth edge displacement of both left and right earth edges between times $t_1 - t_2$ and $t_1 - t_3$.

Running program: Enter the two letter keyin (currently GC) to initiate the program. There are no parameters.

Program output: This program computes coefficients for a set of Chebyshev polynomials for left and right earth edges. These coefficients are stored in COMMON/NAVCOM/.

6. Compute attitude from landmarks (navigate).

Set-up: Several landmark measurements should have been made from the ATIS-6 images and stored in the regular McIDAS navigation file. The t_1 landmarks, from at least three different locations, should have computation code \emptyset . Landmarks for later times should use code 3 $\emptyset\emptyset$ and be used as a check on the navigation.

Running program: Enter the keyin and parameters:

AN SSYYDDD \emptyset \emptyset (P)

* Program output: This program computes a satellite attitude and stores the yaw, pitch and roll values in COMMON/NAVCOM/ and, via an SQ call to DX, in the McIDAS navigation file.

IV. Software Internal Description

This section contains descriptions of the computer programs and subroutines developed for the ATS-6 navigation model. These programs are available on NASA's AOIPS, on SSEC's McIDAS and most are also available on the University of Wisconsin's Univac 1110. There are some variations in the main programs to allow for peculiarities of each system. The code for the tape read subroutines and for subroutines CRKTHR and CRKATS are unique to each system but yield identical results. Subroutines APCH, APFS and CNPS are from IBM's Scientific Subroutine Package (SSP) and are not documented here. Appendix E of this report contains source code listings for the McIDAS and AOIPS versions of the main programs and for most subroutines. Fig. IV.1 illustrates the coordinate system used in these programs. This section contains three parts:

- A. Description of procedure used by main programs
- B. Entries in common block NAVCOM
- C. Subroutine function descriptions

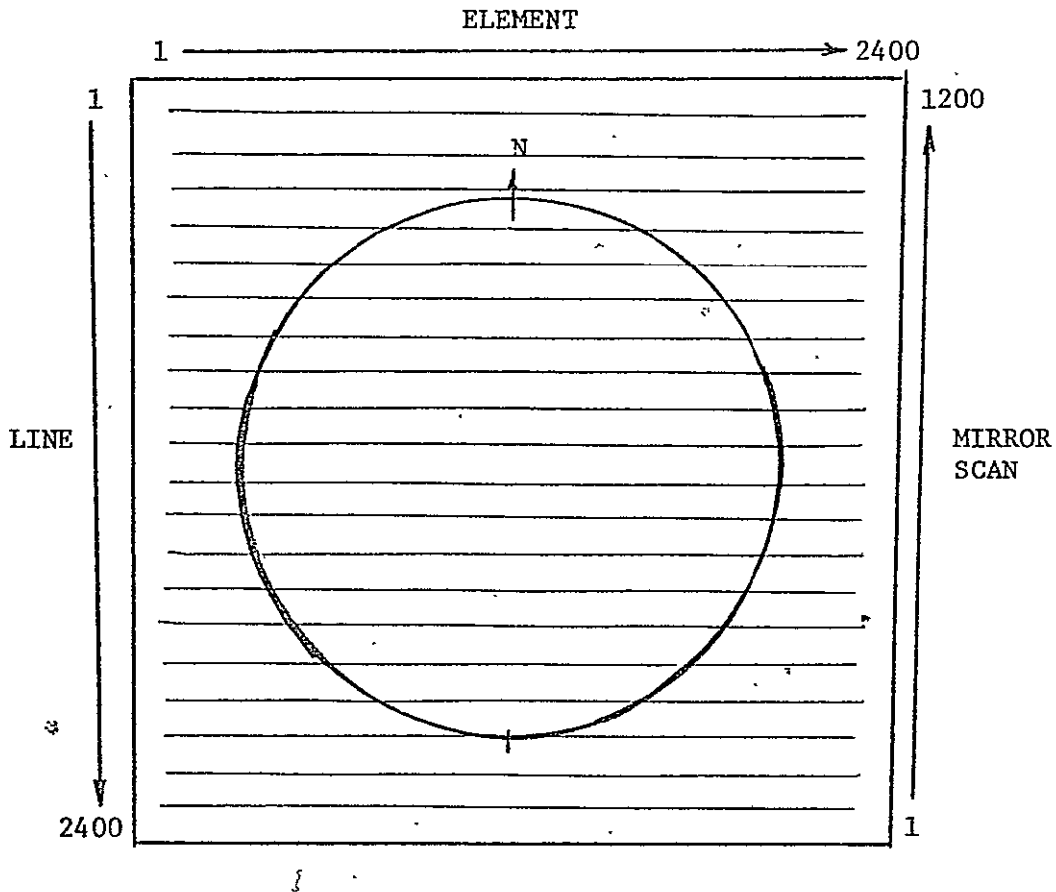

Figure IV.1. ATS-6 Image Coordinate Systems. The ATS-6 satellite scans from south to north with 1200 scans per image. In a visible image each scan consists of 2 lines for a total of 2400 lines per image. The satellite coordinate lines used are numbered 1 to 2400, north to south to be consistent with the convention for SMS images. Satellite coordinate elements are numbered 1 to 2400 left to right. Infrared image data only have one line per scan (but 2400 elements per line). Infrared lines are repeated on image sector loads by LATSF to keep the aspect ratio 1:1 and to keep the coordinates the same for visible and infrared.

ORIGINAL PAGE IS
OF POOR QUALITY

- A. This section gives a description of the procedure executed by each of the main programs.

A6INT - Initialize NAVCOM

1. Make selected entries in COMMON/NAVCOM/.
2. Print all entries in COMMON/NAVCOM/.
3. If two satellite orbit positions entered, call GASORB to convert to position and velocity.
4. Note: This program only used on AOIPS.

OFSTG - Generate offset data

1. Advance to first even numbered scan to be used (scan 800) by:
 - a) Read tape record (IOTPIN)
 - b) Crack out scan number (CRKTHR)
 - c) If desired scan missed print message and modify, start scan number
 - d) Loop back to a.
2. Check to see that following record contains next lower numbered odd scan. If not, modify desired even scan number and return to 1.
3. Desired even and odd scans found. Back up and read whole records into arrays and crack out IR brightness values (CRKATS).
4. Compute offsets for this scan pair. See report of 31 October 1977 Appendix G for details.
5. Add computed offsets and weights to accumulated values for each element position.
6. Print table of element numbers, offsets, and weights.
7. Store number of points and element numbers in common block BUFF1. Store weights and offsets in common block BUFFER. On McIDAS these values are stored in the file OFFSTD.

OFSTF - Fit polynomial for offset data

1. Pick up valid element range as input.
2. Transfer selected range of element numbers, with corresponding offsets and weights to array DATI.
3. Call subroutine APCH to set up matrix for least squares fit.

4. Call subroutine APFS to invert matrix and compute coefficients for least squares set of Chebyshev polynomials.
5. Store coefficients, scaling factors, number of coefficients and valid element range in common block NAVCOM.

LATSF -- Load ATS-6 image segment

1. Input information on data request (coordinates, etc.)
2. Set up image label and write to disk.
3. Call subroutine GENOFF to set up a table of offsets, for every element position to be read in, by evaluating the set of Chebyshev polynomials stored in common block NAVCOM.
4. Advance to first data record.
 - a) Skip two header records
 - b) Read a partial record from tape
 - c) Call CRKTHR to crack out scan number
 - d) If desired start scan not reached, go back to b.
5. Back up one record so entire record can be read.
6. Read image segment
 - a) Read a record.
 - b) Check scan number. If less than last scan to be read in, terminate image load.
 - c) Pass Visible-2 data to subroutine LINGRB to select and repack desired line segment.
 - d) Write image line segment to digital disk area.
 - e) Pass Visible-1 data to subroutine LINGRB to select and repack desired line segment.
 - f) Write image line segment to digital disk.
 - g) Pass Infrared data to subroutine LINGRB to select and repack desired line segment.
 - h) Write infrared image line to digital disk.
 - i) Write infrared image line to digital disk a second time so that visible and infrared coordinates match.
7. Done now; rewind tape.

EDGFT - Fit polynomials to earth edges

1. Do curve fit for $t_1 - t_2$ image pair then for $t_1 - t_3$ image pair.
 - a) Read a wind from disk file.
 - b) Check for valid year, day, times, error code. If invalid, return to step a.
 - c) If element position of vector less than picture center element, store scan number, shift in array for left edge.
 - d) If element position of vector greater than picture center element, store scan number, shift in array for right edge.
 - e) Loop back to a till end of wind file encountered.
 - f) Fill array DATA with scan numbers, shifts for left edge. Pass array to subroutine APCH to set up matrix.
 - g) Pass matrix from APCH to subroutine APFS to invert matrix and compute coefficients for set of Chebyshev polynomials.
 - h) Store coefficients, scaling factors in common block NAVCOM.
 - i) Repeat steps f, g, h for data from right edge.
 - j) Determine valid argument range for left and right edges. Determine the overlapping portion of valid argument range for left and right edges and store this overlapping portion in common block NAVCOM.

ATSNV - Navigate ATS-6 image from landmarks

1. Read landmarks from landmark file.
2. Convert integer values to floating point.
3. Pass landmark data to subroutine ATTTUD to compute satellite attitude.
4. The McIDAS version stores the attitude in the navigation file by SQing DX.
5. Compute and list residuals.
 - a) Pass picture time, latitude, longitude of landmark to subroutine ES to compute line and element.
 - b) Compute residual equals measured value minus computed value for lines and for elements.
 - c) List values and loop back to a through all landmarks.

B. Entries in common block NAVCOM.

NAVN	Navigation sequence number.
INAV	Flag to indicate type of navigation.
IYR	Year of date for which navigation is valid.
IDAY	Day of year for which navigation is valid.
TOTLIN	Total number of lines in image (= 2400.).
DECLIN	Total sweep angle in line direction (= 19.92 degrees).
TOTIEL	Total number of elements across image (= 2400.).
DEGELE	Total scan angle in element direction (= 20.07 degrees).
PICLIN	Picture center line.
PICELE	Picture center element.
TMP\$CL	Scan period (nom. .02 minutes).
IOYR	Year of date for orbit values (IOYR = IYR).
IODAY	Day of year for orbit values (IODAY - IDAY).
TM	Time of orbit location (minutes, GMT).
R1X	X-component of location of time TM (earth radii).
R1Y	Y component of satellite location of time TM (earth radii).
R1Z	Z component of satellite location of time TM (earth radii).
R1DX	X component of satellite location of time TM (earth radii/minute).
R1DY	Y component of satellite velocity at time TM (earth radii/minute).
R1DZ	Z component of satellite velocity at time TM (earth radii/minute).
PITCH	Pitch angle of rotation from BC to PF coordinates. Satellite attitude (radians).
ROLL	Roll angle of rotation from BC to PF coordinates. Satellite attitude (radians).
YAW	Yaw angle of rotation from BC to PF coordinates. Satellite attitude (radians).

PTIM(3) Picture start times for the three images for which earthedge correction applies. PTIM(1) is the time of the reference image. (Time in minutes, GMT)

TMN(3) Minimum time of time over which earthedge correction valid. Subscript corresponds to image number as in PTIM.

TMX(3) Maximum time of time over which earthedge correction valid. (e.g. earth edge correction may be used for scan time t within image starting at PTIM(2) only if $TMN(2) \leq t \leq TMX(2)$). Units are minutes, GMT. $PTIM(i) \leq TMN(i) \leq TMX(i)$.

Note: For earthedge correction arrays, dimensions of value 2 refer to image pair. 1 => PTIM(1) - PTIM(2) shifts; 2 => PTIM(1) - PTIM(3) shifts.

NLCOEF(2) Number of coefficients in polynomial for left edges.

NRCOEF(2) Number of coefficients in polynomial for right edge.

SCLLØ(2) Offset for scaling argument value (scan number) for left edges.

SCLL1(2) Multiplier for scaling argument value (scan number) for left edges.

ELCOEF(11,2) Coefficients of set of Chebyshev polynomial for left edges.

SCLRØ(2) Offset for scaling argument value (scan number) for right edges.

SCLR1(2) Multiplier for scaling argument values (scan number) for right edges.

ERCOEF(11,2) Coefficients of set of Chebyshev polynomial for right edge.

NASCEF Number of coefficients in polynomial for alternate scan correction.

SCLASØ Offset for scaling argument (scan number) for alternate scan offset.

SCLAS1 Multiplier for scaling argument value (scan number) for alternate scan correction.

IELEMN Minimum element number for which alternate scan correction applies.

IELEMX Maximum element number for which alternate scan
correction applies.

ASCOEF(16) Coefficients fo set of Chebyshev polynomials for
alternate scan correction.

C. Subroutine Function Description

Name: BCTOPF

Call: CALL BCTOPF (X, Y, Z, IDIR)

Input Parameters:

X, Y, Z Satellite orientation in body centered (IDIR = 1) or
 picture frame (IDIR = 2) coordinates

IDIR Direction to rotation
 IDIR = 1 Body centered to picture frame
 IDIR = 2 Picture frame to body centered

Returned Values:

X, Y, Z Satellite orientation in picture frame (IDIR = 1) or
 body centered (IDIR = 2) coordinates.

Algorithm:

BCTOPF uses subroutine ROTATE to create a rotation matrix from the yaw, roll and pitch angles computed by the navigation program. It then multiplies the vector (X, Y, Z) by the matrix (IDIR = 1) or its transpose (IDIR = 2).

Reference:

For discussion of the coordinate systems see "Design and Testing of the Navigation Model for Three Axis Stabilized Earth Oriented Satellites Applied to the ATS-6 Satellite Image Data Base" progress report for 17 Nov. 1975, appendix pp. 2-4 or progress report for 31 June 1976, appendix pp. 2-4.

Name: CRKATS

Call: CALL CRKATS (N, S, D)

Input Values:

N - Number of data words to crack out.

S - Source array of 12-bit words stored in sequence as a continuous bit string after being read from tape.

Returned Values:

D - Destination array of full words.

Function:

ATS-6 experimenter history tapes are written with the image data stored in the 9 least significant bits of successive 12-bit words. CRKATS extracts the 8 most significant data bits (bits 8-1 of a 12-bit word numbered 11-0) and stores the resulting data value in a full computer word.

Name: CRKTHR

Call: CALL CRKTHR (N, S, D)

Input Values:

N - Number of 12-bit words to crack out.

S - Source array of 12-bit words stored in sequence as a continuous bit string after being read from tape.

Returned Values:

D - Destination array of whole words.

Function:

ATS-6 experimenter history tapes are written with the data stored in 12-bit words (actually thirds of 36-bit words). CRKTHR places these 12-bit words in whole words (16-bits for PDP-11).

Name: EDGCOR

Call: CALL EDGCOR (PTIME, ALIN, DELLIN, DELELE)

Input Parameters:

PTIME - Picture start time (minutes, GMT).

ALIN - Line coordinate value at which correction is to apply.

Returned Values:

DELLIN - Line correction value.

DELELE - Element correction value.

Function:

EDGCOR requires that left and right earth edge shift polynomials be stored in COMMON/NAVCOM/. The current version only allows for three picture start times to be in use at once.

EDGCOR evaluates the earth edge shift polynomials for left and right edges, then converts these values to line and element shifts. The polynomial only applies to the line range for which earth edges were measured. Outside this range, the value zero will be returned.

Name: ERTOER

Call: CALL ERTOER (XLAT, XLON, SE, YE, ZE, IDIR)

Parameters:

XLAT Latitude (degrees) of a point on the earth.

XLON Longitude (degrees) of same point on the earth.

XE, YE, ZE Cartesian coordinates in coordinate system rotating with earth (kilometers).

IDIR Direction of transformation.

Function:

Converts coordinates of a point on the earth from latitude, longitude to rotating Cartesian coordinates (IDIR = 1) or vice versa (IDIR = 2).

References:

See progress report of 17 Nov. 1975 or 31 June 1976, appendix pp. 2-4 for coordinates.

See also subroutine ERTOST.

Name: ERTOST

Call: CALL ERTOST (XE, YE, ZE, X, Y, Z, IDIR, TIME)

Parameters:

XE, YE, ZE Cartesian coordinates (kilometers) of a point on earth's surface in rotating coordinate system.

X, Y, Z Unit vector in inertial coordinates pointing from satellite to point (XE, YE, ZE) on Earth's surface.

IDIR Direction of transformation
 IDIR = 1 => (XE, YE, ZE) → (X, Y, Z)
 IDIR = 2 => (X, Y, Z) → (XE, YE, ZE)

TIME Time of day (minutes, GMT)

Function:

ERTOST a unit vector pointing from the satellite to a given point on the earth (IDIR = 1) or given a pointing vector it computes the location, if any, on the earth's surface that the vector is pointing at (IDIR = 2).

Reference:

See progress report of 17 Nov. 1975 or 31 June 1976, appendix pp. 2-4 for coordinate.

Related subroutine ERTOER, STTOLV.

Name: ES

Call: CALL ES (PTIME, XLAT, XLON, XLIN, XELE)

Input Parameters:

PTIME - Picture start time (minutes, GMT).

XLAT - Latitude (degrees) of a point on the earth's surface.

XLON - Longitude (degrees) of that point.

Returned Values:

XLIN - Line coordinate in the image picture frame coordinate system.

XELE - Element coordinate in image picture frame coordinate system.

Function:

Subroutine ES does an earth (latitude, longitude) to satellite (line, element) coordinate transform based on the satellite's attitude, orbit position, and, if available, attitude correction based on measurement of earthedged shifts.

References:

See subroutine SE.

Name: FLALO

Call: XLAT = FLALO (ILAT)

Input Value:

ILAT = Latitude (or longitude) integer value in the format +DDMMSS.
(For PDP-11 an INTEGER*4 value.)

Return Value:

XLAT = Latitude (or longitude) in degrees (floating point).

Function:

Converts an angle stored as an integer in degrees, minutes, seconds format to floating point degrees.

Name: FLIP

Call: CALL FLIP (A, B, I, N, ALTRET)

Parameters:

A - an NxN matrix

B - an NxN matrix

I - row on which to perform operation

N - dimension of A and B

ALTRET - flag indicating an error (LOGICAL)

Return:

A, B are returned in modified form.

Function:

All rows greater than I are added to row I. The same operation is performed on matrices A and B.

Reference: _____

This subroutine is used only by subroutine INVERT.

Name: FTIME

Call: TIME = FTIME (ITIME)

Input Parameters:

ITIME = Integer time of day in the form HHMMSS. (INTEGER*4 on the PDP-11.)

Returned Value:

TIME = Time of day in minutes (floating point).

Function:

Converts a time of day in the packed integer format hours, minutes, seconds to time of day in minutes (floating point).

Name: GASORB

Call: CALL GASORB (R1, T1, R2, T2)

Input Parameters:

R1 Position vector of satellite at time T1 in earth inertial reference frame.

T1 Time (minutes, GMT) at which satellite is a position R1.

R2 Position vector of satellite at time T2.

T2 Time (minutes, GMT) of position R2.

Returned Values: Note -- results are stored in COMMON/NAVCOM/.

TM - Time of position. TM = T1

R1X, R1Y, R1Z - Position of satellite at TM.
(R1X, R1Y, R1Z) = R1/RE
Where RE = radius of earth.

R1DX, R1DY, R1DZ - Velocity of satellite at time TM.

Function:

Given two position vectors and their corresponding times, GASORB computes the position and velocity of the satellite at the time of the first given position vector. The method used is an f,g series from the method of Gauss.

Reference:

Escobal, P. R. Methods of Orbit Determination, John Wiley & Sons, 1965, pp. 196, 197.

See also subroutine ORBIT.

Name: GENOFF

Call: CALL GENOFF (IUELE, NELES)

Input Parameters:

IUELE First element of offset array.

NELES Number of elements in offset array."

Function:

The subroutine GENOFF evaluates the alternate scan correction polynomial for all element values across the image to be read in. The values are stored in an array in COMMON/OFFSET/. This array is then used by the program which loads ATS-6 images (LATSF or LDATSF).

References:

See information on programs LATSF and OFSTF and on COMMON/NAVCOM/.

Name: INVERT

Call: CALL INVERT (AA, B, N, ALTRET)

Input Parameters:

AA - an NxN matrix

N - dimension of AA and B

Return Values:

B - the inverse of AA

ALTRET - a flag to indicate AA is singular (LOGICAL)

Function:

INVERT returns in B the NxN inverse of the matrix AA. If AA is singular, ALTRET is set to .TRUE.

Reference:

See also subroutines FLIP, MINMIZ.

Name: LINGRB

Call: CALL LINGRB (INDATA, ISDIR, IELE, NELES, IBDF, IOUTD)

Input Parameters:

INDATA An array containing the bit string for either the Visible-1, Visible-2 or Infrared sensor as read from tape. Array actually starts 72 bits before first data word.

ISDIR Indicates scan direction. 0 => Even numbered scan.
1 => Odd numbered scan.

IELE First element of desired line segment.

NELES Number of elements in line segment.

IBDF Sampling factor. (IBDF = 1 only)

Returned Values:

IOUTD Output array with data packed one pixel per 8-bit byte.

Function:

This subroutine unpacks pixel data from the bit string read from magnetic tape. It then selects out the desired line segment (512 elements on AOIPS), shifts the even scans based on the evaluation of the alternate scan correction polynomial, and stores the pixels in an array to be written in the image file.

References:

See main program LATSF.

Name: LS

Call: CALL LS(X, Y, VAL, DD, DIR)

Input Parameters:

X Starting point for line search (a vector).
 DD Unnormalized directional derivative $\overline{\nabla S(Y)} \cdot \overline{DIR}$.
 DIR Direction to do search (a vector).

Returned Values:

Y The selected point (a vector).
 VAL Value of the objective function S evaluated at Y.

Function:

This routine performs an Armijo line search from the point "X" in the direction "DIR" and returns the selected point in "Y" and the objective function value $S(Y)$ in "VAL". On call, "DD" is the unnormalized directional derivative $\overline{\nabla S} \cdot \overline{DIR}$. This line search routine returns in Y the point $X + 2^{-N} \cdot \overline{DIR}$ where N is the least nonnegative integer such that $-S(2^{-N} \cdot \overline{DIR})$ represents at least 40% of the functional drop in the linearization of S at X in moving from X to $X + 2^{-N} \cdot \overline{DIR}$.

References:

See also subroutine MINMIZ and function S. See the report for 17 Nov. 1975 Appendix section IV or report for 31 June 1976 Appendix section II.C.

Name: MINMIZ

Call: CALL MINMIZ (PTIN, PTOUT, GNORM, VAL, ITN)

Input Parameter:

PTIN Starting point for search for minimum value of objective function
(PTIN is a vector)

Returned Values:

PTOUT .Optimal point. The objective function has a minimum at PTOUT.
(PTOUT is a vector)

GNORM The norm of the gradient of the objective function at PTOUT.

VAL The value of the objective function at PTOUT.

ITN Number of iterations done.

Function:

MINMIZ finds the point PTOUT at which an objective function is a minimum. In this case PTOUT is the satellite's attitude (PITCH, ROLL, YAW). The objective function is defined in the reports (report of 17 Nov. 1975 Appendix eqn. 15, report of 31 June 1976 Appendix eqn. 17). Basically MINMIZ serves as a driver for PRTIAL, INVERT and LS.

References: See also subroutine ATTTUD.

Name: NRMLIZ

Call: CALL NRMLIZ (VX, VY, VZ, VNORM)

Input Parameters:

VX, VY, VZ Cartesian components of any vector.

Returned Values:

VX, VY, VZ - Normalized components of the input vector.

VNORM - Length of the input vector.

Function:

NRMLIZ computes the length of the vector with components (VX, VY, VZ) then divides each component by that length to return a unit vector.

Name: ORBIT

Call: CALL ORBIT (X, Y, Z, T)

Input Parameters:

T - Time of day (minutes, GMT)

Returned Values:

X, Y, Z - Position of satellite at time T (kilometers)

Function:

Given the position and velocity of the satellite at some reference time as computed by GASORB, the subroutine ORBIT computes the satellite's position at the time T.

Reference:

Escobal, P.R. Methods of Orbit Determination, John Wiley & Sons, 1965, pp. 427, 428.

Name: PFTOTC

Call: CALL PFTOTC (XLIN, XELE, X, Y, Z, IDIR, INIT)

Parameters:

XLIN Line number of a point on the ATS-6 image.

XELE The element number of that point.

X, Y, Z Unit vector, in the picture frame coordinate system, pointing
 at location defined by (XLIN, XELE).

IDIR Direction of coordinate transformation.

INIT Initialization flag. Set INIT = 1 before first call.

Function:

PFTOTC converts from picture frame cartesian (X, Y, Z) coordinates to
picture frame image (LINE, ELEMENT) coordinates (IDIR = 1) or vice versa
(IDIR = 2).

References:

See progress report of 17 Nov. 1975 or 31 June 1976, appendix, pp. 2-4,
for coordinates.

See also subroutine BCTOPF.

Name: PRTIAL

Call: CALL PRTIAL (PT, GRAD, HESS)

Input Parameters:

PT Point (vector) at which to evaluate GRAD and HESS.

Returned Values:

GRAD The gradient of the objective function, evaluated at PT.

HESS The hessian of the gradient function evaluated at PT.

Function:

PRTIAL computes values of gradient and hessian for a given function.

References:

See also subroutine MINMIZ. See the reports of 17 November 1975 Appendix page 10 ff or report of 31 June 1976 Appendix page 13 ff.

Name: ROTATE

Call: CALL ROTATE (A, R, IR, IDERIV)

Parameters:

A A matrix.

R An angle of rotation (radians)

IR Axis number (1, 2, 3) .

IDERIV Derivative of rotation matrix.

Function:

This routine returns in "A" the product of the input matrix "A" and a matrix RM, where, if "IDERIV=1", RM represents a rotation through an angle "R" (in radians) about the axis "IR". IF IDERIV=2, the first derivative of RM is operated on A, and if IDERIV=3, the second derivative of RM is used.

References: See also subroutine PRTIAL.

Name: S

Call: SVAL = S (PT)

Input Parameter:

PT The point (a vector) at which S is evaluated.

Returned Value:

S The objective function which is minimized in computing the satellite attitude.

Function:

S is the objective function which is minimized by MINMIZ in computing the satellites attitude. See the report of 31 June 1976 Appendix equation 17 or report of 17 November 1975 Appendix equation 15.

References:

See also the subroutines MINMIZ and LS.

Name: SATEAR

Call: CALL SATEAR (PICTIM, XLIN, XELE, XLAT, XLON, ITYPE, INAV, BETAIN,
BETDOT, ATFRAC)

Parameters:

PICTIM	Picture start time (minutes, GMT)
XLIN	Satellite image line (master coordinate)
XELE	Satellite image element (master coordinate)
XLAT	Latitude (degrees, +North, -South)
XLON	Longitude (degrees, +East, -West)
ITYPE	Type of conversion 1 => Satellite to earth 2 => Earth to satellite
INAV BETAIN BETDOT ATFRAC	} Dummy variable used so call will match SMS version.

Function:

Subroutine SATEAR calls subroutines SE or ES.

Name: SE

Call: CALL SE (PTIME, XLIN, XELE, ALOT, ALON)

Input Parameters:

PTIME - Picture start time (minutes, GMT).

XLIN - Line number of a point on the ATS-6 image.

XELE - Element number of that point.

Returned Values:

ALAT - Latitude (degrees) of the point on the earth's surface at (XLIN, XELE).

ALON - Longitude (degrees) of that point.

Function:

Subroutine SE does a satellite (line, element) to earth (latitude, longitude) coordinate transform based on the satellite's attitude, orbit position, and, if available, attitude corrections based on measurement of earthedge shifts.

References:

See also subroutine ES.

Name: STTOLV

Call: CALL STTOLV (X, Y, Z, IDIR, TIME)

Parameters:

X, Y, Z Unit pointing vector in the satellite inertial coordinate system or in the satellite local vertical coordinate system.

IDIR Direction of transformation.
Satellite inertial to local vertical (IDIR = 1)
Local vertical to satellite vertical (IDIR = 2)

TIME Time at which transform applies.
(minutes, GMT)

Function:

STTOLV uses the satellite's position at time TIME, and converts a unit vector in the satellite inertial coordinate system to the satellite's local vertical system (IDIR = 1) or vice versa (IDIR = 2).

Reference:

See progress report for 17 Nov. 1975 or 31 June 1976, appendix, pp. 2-4.

See also subroutines ERTOST, LVTOBC, and BCTOPF.

Name: UNIT

Call: CALL UNIT (A)

Returned Values:

A - a 3x3 identity matrix

Function:

Subroutine UNIT returns a 3x3 identity matrix in array A.

References

1. Kuhlow, W. W., Design and Testing of the Navigation Model for Three Axis Stabilized Earth Oriented Satellites Applied to the ATS-6 Satellite Image Data Base, Progress Report for Period Ending 17 November 1975, Contract Number NAS5-20974, University of Wisconsin.
2. Kuhlow, W. W., G. C. Chatters, Design and Testing of the Navigation Model for Three Axis Stabilized Earth Oriented Satellites Applied to the ATS-6 Satellite Image Data Base, Progress Report for Period Ending 31 June 1976, Contract Number NAS5-20974, University of Wisconsin.
3. Kuhlow, W. W., G. C. Chatters, Design and Testing of the Navigation Model for Three Axis Stabilized Earth Oriented Satellites Applied to the ATS-6 Satellite Image Data Base, Progress Report for Period Ending 31 October 1977, Contract Number NAS5-20974, University of Wisconsin.

APPENDIX A

BASIC NAVIGATION MODEL APPLIED TO ATS-6 IMAGE DATA BASE

3

Contents

	page
NOMENCLATURE	A-1
I. PRELIMINARIES	A-2
A. Coordinate Systems	A-2
B. Convention for Orthogonal Matrices	A-5
C. Orbit Methods Used in Predicting Satellite Position $\vec{r}_s(t)$	A-6
II. THE NAVIGATION MODEL	A-6
A. Earth \rightarrow Satellite Transformation	A-6
B. Satellite \rightarrow Earth Transformation	A-11
C. Navigation Optimization Procedure	A-13

NOMENCLATURE

Coordinate Systems (C.S.)

EI = Earth-centered Inertial

ER = Earth-centered Rotating

LV = Local Vertical
(satellite-centered)BC = Body Centered
(satellite-centered)PF = Picture Frame
(satellite-centered)

Orthogonal Matrices

 R_{LV} = rotation into LV C.S. R_{BC} = rotation into BC C.S. R_{PF} = rotation in PF C.S. R_A = optimized "navigation"
matrix $R(\theta, k)$ = rotation about axis
k (k=1,2,3) in a ccw
sense by an angle θ

Vectors

 \hat{r} = unit vector \vec{r}_s = satellite radius vector \vec{r}_1 = landmark pointing vector \vec{r}_2 = earth-coordinate, EI C.S. \vec{r}_E = earth-coordinate, ER C.S. \hat{r}_{LV} = pointing vector in LV C.S. \hat{r}_{BC} = pointing vector in BC C.S. \hat{r}_{PF} = pointing vector in PF C.S. $\hat{e}_3 = (0, 0, 1)^T$

Other

 $\theta_y, \theta_r, \theta_p$ = attitude yaw, roll,
pitch angles θ_L, ϕ_L = geodetic latitude, longitude θ_E = sidereal time of Greenwich prime
meridian ρ_L, ρ_E = radians/line, radians/element λ = mirror step angle δ = mirror sweep angle α_i = navigation parameter $\bar{\alpha}_i$ = optimized navigation parameterLIN, ELE = satellite image coordinates:
Line, Element L_c, E_c = picture-center coordinates
(line, element) e = eccentricity of earth oblate
spheroid model r_{eq} = earth's equatorial radius r_p = earth's polar radius s = distance from satellite to landmark t = time t_M = epoch time, lies within image
frame interval $\| \cdot \|$ = Euclidean norm $| \cdot |$ = absolute value operator

I. PRELIMINARIES

A. Coordinate Systems

All coordinate systems used in the model are 3-D right-handed orthogonal coordinate systems. There are five all together. Two have their origins placed at the dynamical center of the earth.

The plane formed by the x- and y-axes of the earth-centered inertial coordinate system (EI) lies in the earth's equatorial plane. The x-axis points at the vernal equinox (γ) which is assumed to be inertially fixed and the z-axis points north. Rotating relative to this inertial frame is the earth-centered rotating coordinate system (ER) with its x-axis passing through the Greenwich meridian and its z-axis coincident with the EI z-axis (Fig. A.1).

In the local vertical (LV) system, the z-axis points to the center of the earth, i.e. the unit vector representing this axis at time t is given as $\hat{z} = -\vec{r}_s(t) / \|\vec{r}_s(t)\|$, where \vec{r}_s is the satellite radius vector (Fig. A.1). The x-axis is parallel to the earth's equatorial plane and nominally points east.

Fixed in the satellite body is the body-centered (BC) coordinate system whose axes are nominally coincident with the LV system. Departures from this alignment are measured by the yaw, pitch, and roll time dependent angles which in part make up the attitude telemetry data. These rotations are explicitly defined later on. Also nominally coincident with these coordinates systems is the last to be defined, the image or picture frame (PF) coordinate system (Fig. A.2). The z-axis points to the picture center (earth image center) which for ATS-6, is the image point occurring at the midpoint of the mirror sweep angle for the mid-mirror scan number of a full

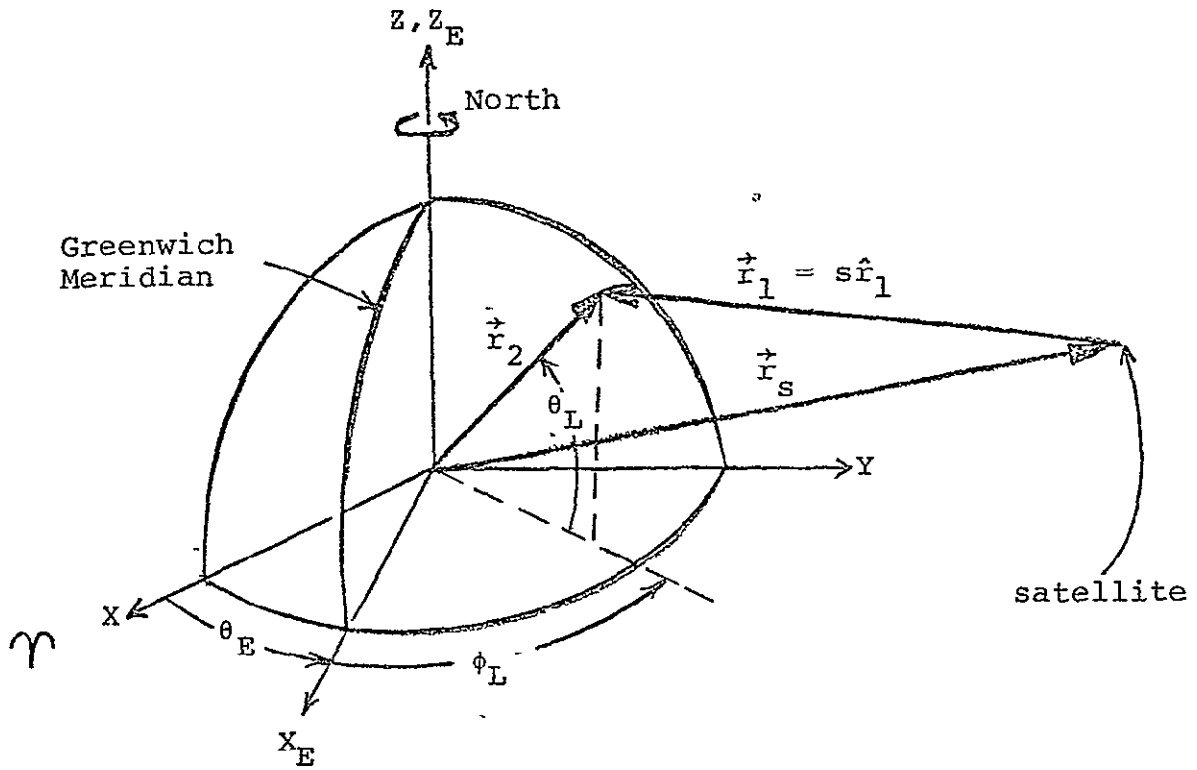

Figure A.1. Satellite-Earth Geometry (See Text for definition of symbols)

ORIGINAL PAGE IS
OF POOR QUALITY

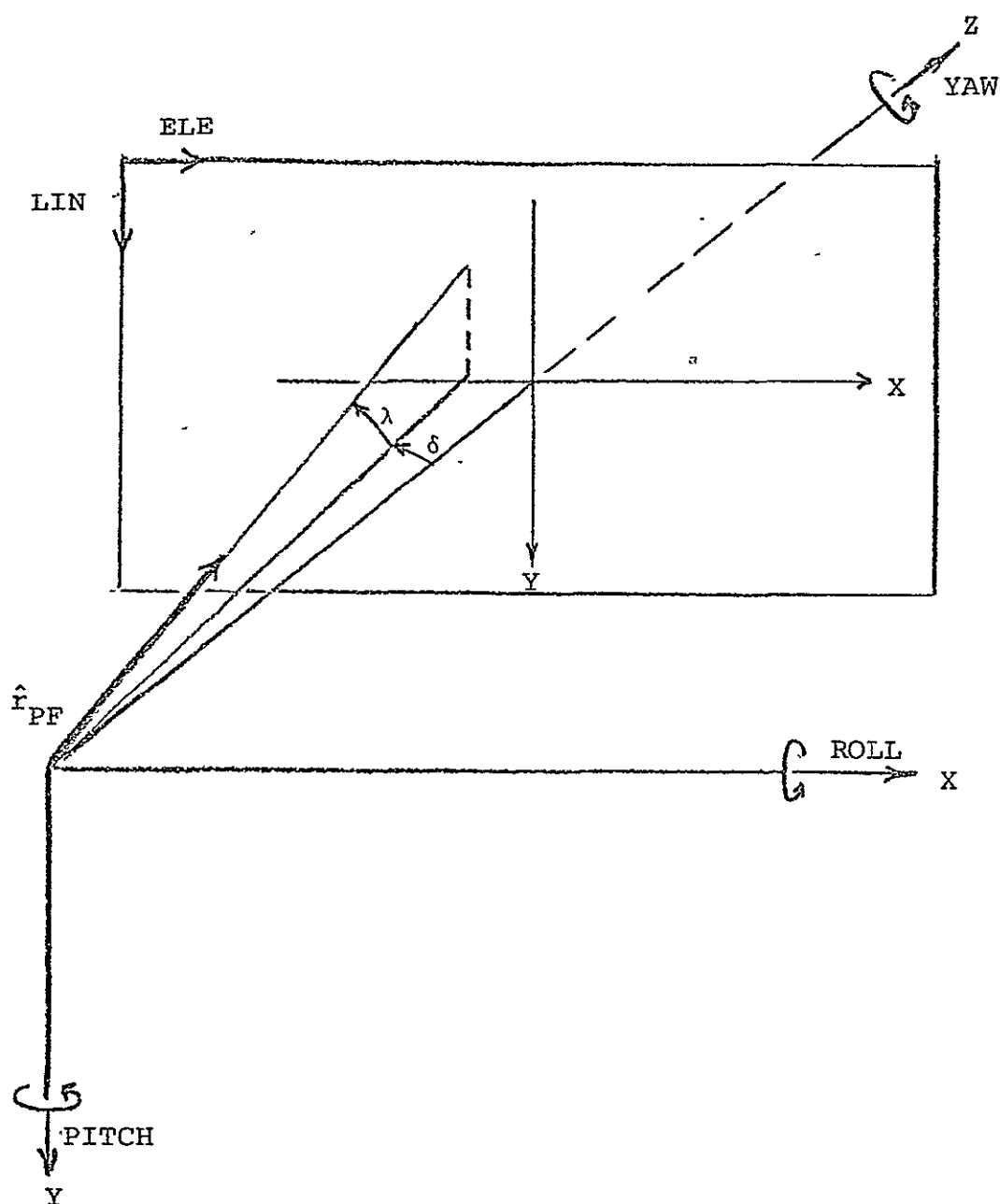

Figure A.2. Picture Frame (PF) Coordinate System
(See Text for explanation of symbols)

image frame scan. (For ATS-6, one complete image scan consists of 1200 mirror scans with 2400 samples or elements per scan line.) The PF x-axis is parallel to the center mirror sweep scan at the picture center and nominally points east.

B. Convention for Orthogonal Matrices

Two basic orthogonal transformation representations in transforming a vector from one coordinate system to another with common origin are given here. Their forms arise naturally in the development of the navigation model depending on convenience or available information.

Given two coordinate systems with a common origin whose axes are unprimed xyz and primed $x'y'z'$ respectively, let R represent the orthogonal transformation of the vector \vec{r} , (whose components are expressed in the unprimed system) to the vector \vec{r}' whose components are expressed in terms of the primed system, i.e. $\vec{r}' = R\vec{r}$.

The first form R can take is, in matrix representation, $R = [\hat{x}|\hat{y}|\hat{z}]^T$, where \hat{x} , \hat{y} , \hat{z} are the unit column vectors of the primed coordinate axes whose components are expressed in the unprimed coordinate system. The "T" refers to the transpose of the matrix. To see that this transformation is valid, one need only to carry out the operation implied,

$$\vec{r}' = [\hat{x}|\hat{y}|\hat{z}]^T \vec{r} = (\hat{x} \cdot \vec{r}, \hat{y} \cdot \vec{r}, \hat{z} \cdot \vec{r})^T.$$

Thus, $\hat{x} \cdot \vec{r}$, $\hat{y} \cdot \vec{r}$, $\hat{z} \cdot \vec{r}$ represent the projections of \vec{r} onto the x' , y' , z' axes respectively. This is precisely the representation of \vec{r} in the primed system.

The second form of R is expressed in terms of rotation angles where in its simplest form $R = R(\theta, k)$ represents a rotation by an angle θ counter-

clockwise about the k-th axis as viewed from above where k=1,2,3 refers respectively to the x,y,z-axes. Thus, using the conventions defined above, if the z and z' axes were coincident and the x'y'z' system were rotated by an angle θ counterclockwise relative to the xyz system about the z-axis,

$$\vec{r}' = R(\theta,3)\vec{r} = \begin{bmatrix} \cos \theta & \sin \theta & 0 \\ -\sin \theta & \cos \theta & 0 \\ 0 & 0 & 1 \end{bmatrix} \vec{r} . \quad [\text{ROTATE}]^*$$

In general for $R(\theta_K, k)$,

$$R_{ki} = R_{ik} = \begin{cases} 0 & \text{if } i \neq k \\ 1 & \text{if } i = k \end{cases} ; R_{ii} = \cos \theta, \quad i \neq k; R_{ij} = -R_{ji} = \sin \theta, \\ i < j \text{ and } i, j \neq k .$$

With this notation, the sequence of Euler rotations can be represented in a compact form. For example, the three rotations about the ATS-6 body axes to define the ATS-6 attitude relative to the LV coordinate system are, in sequence, a ccw rotation by an angle θ_y about the BC z-axis (yaw), followed by a ccw rotation by an angle θ_r about the BC x-axis (roll), followed by a cw rotation by an angle θ_p about the BC y-axis (pitch). Thus a vector expressed in the LV system \vec{r}_{LV} , is transformed to the BC system (\vec{r}_{BC}) by the operation:

$$\vec{r}_{BC} = R(-\theta_p, 2) R(\theta_r, 1) R(\theta_y, 3) \vec{r}_{LV} , \quad [\text{LVTOBC}]$$

where the angles θ_y , θ_r , θ_p are generally dependent on time.

C. Orbit Methods Used in Predicting Satellite Position, $\vec{r}_s(t)$

The orbit parameters used in the model are derived from the ephemeris data available from the ATS-6 magnetic tapes. These data are in the form of position (\vec{r}_s) and velocity ($\dot{\vec{r}}_s$) components expressed in the EI coordinate system approximately every three seconds of ephemeris time. For a two body

*Note: Label in brackets (e.g. [ROTATE]) is corresponding FORTRAN subroutine. See Appendix E for listing.

orbit, a position and velocity vector at any time is theoretically sufficient to uniquely determine the orbit. However, the velocity vectors, unlike the position vectors, are not given with sufficient accuracy for the purposes of this model. Therefore, a Gaussian orbit determination method is used in which two position vectors at different times are used to calculate an accurate velocity vector corresponding to one of the selected position vectors. In symbols,

$$\vec{r}_s(t_1), \dot{\vec{r}}_s(t_2) \rightarrow \vec{r}_s(t_1), \dot{\vec{r}}_s(t_1), \quad t_1 \neq t_2. \quad [\text{GASORB}]$$

The vector spread between $\vec{r}_s(t_1)$ and $\dot{\vec{r}}_s(t_2)$ must be less than 70° . Once $\vec{r}_s(t_1)$, $\dot{\vec{r}}_s(t_1)$ are determined, the satellite's position for any other time is determined by an iterative f, g computational procedure:

$$\vec{r}_s(t) = f \vec{r}_s(t_1) + g \dot{\vec{r}}_s(t_1). \quad [\text{ORBIT}]$$

The details of the computational algorithms for these two procedures are given elsewhere.[†] A thorough testing of these two routines which are incorporated into the ATS-6 model has indicated that any errors generated by them or by uncertainties in the satellite's position are negligibly small compared to errors arising from other sources.

II. THE NAVIGATION MODEL

A. Earth Coordinates to Satellite Image Coordinates (Subroutine ES)

Let t be the instant at which a point on the earth (landmark) is imaged by the satellite scanning system and let $\hat{r}_1(t)$ be the vector which points from the satellite-center to the landmark in question. However, t is not known. Therefore, we make a guess then use the derived line to get a better value and iterate till the solution converges to within a line. The relation

[†]P. R. Escobal, Methods of Orbit Determination, J. Wiley and Sons, New York, 1965. Gaussian orbit algorithm, pp. 196-197, f, g method, p. 423.

of this vector to the satellite radius vector \vec{r}_s and the landmark \vec{r}_2 is given by:

$$\vec{r}_1(t) = \vec{r}_2(t) - \vec{r}_s(t), \quad [\text{ERTOST}] \quad (1)$$

where \vec{r}_2 , \vec{r}_s , and therefore \vec{r}_1 , are expressed in EI coordinates (Figure 1). The position of the satellite $\vec{r}_s(t)$ is determined from the orbit routine discussed above, while \vec{r}_2 is derived as follows:

$$\vec{r}_2 = R(-\theta_E, 3) \vec{r}_E, \quad [\text{ERTOST}] \quad (2)$$

where $\vec{r}_E = \rho (\cos \theta_L \cos \phi_L, \cos \theta_L \sin \phi_L, (1 - e^2) \sin \theta_L)^T$,

$$\rho = r_{eq} / \sqrt{1 - e^2 \sin^2 \theta_L},$$

θ_L, ϕ_L = the geodetic latitude and longitude of the landmark,

e = eccentricity of the oblate spheroid earth model = 8.1812×10^{-2} ,

r_{eq} = earth's equatorial radius = 6378.15 km.

The landmark \vec{r}_E expressed in ER coordinates is transformed into the EI coordinate system via the transformation $R(-\theta_E, 3)$ where, θ_E , the angle between the x-axes of the two systems at time t is given by

$$\theta_E = a_1 + a_2 * \text{DDD} + a_3 * t \quad [\text{ERTOST}]$$

where, θ_E is the sidereal time of the Greenwich prime meridian,

DDD is the day of the year,

t is universal time,

a_1, a_2, a_3 are constants derived for a specific Julian date; for January 0, 1974

$$a_1 = 99.59477026 \text{ degrees}$$

$$a_2 = .985647336 \text{ degrees/DDD}$$

$$a_3 = .2506844773 \text{ degrees/decimal minute.}$$

It is convenient at this stage to transform the pointing vector \vec{r}_1 into a unit vector, $\hat{r}_1(t) = \vec{r}_1(t) / \|\vec{r}_1(t)\|$. Transformation of \hat{r}_1 into the LV frame is accomplished by R_{LV} ,

$$\hat{r}_{LV} = R_{LV} \hat{r}_1 = [\hat{x}|\hat{y}|\hat{z}]^T \hat{r}_1 \quad [\text{STTOLV}] \quad (3)$$

where, from the definition of the LV coordinate system,

$$\hat{z} = -\vec{r}_s(t) / \|\vec{r}_s(t)\| = -(x_s, y_s, z_s)^T,$$

$$\hat{x} = (\hat{z} \times \hat{e}_3) / \|\hat{z} \times \hat{e}_3\| = (-y_s/d, x_s/d, 0)^T,$$

$$\hat{y} = \hat{z} \times \hat{x} = (x_s z_s/d, y_s z_s/d, -d^2)^T,$$

$$d = \sqrt{x_s^2 + y_s^2},$$

where $x_s^2 + y_s^2 + z_s^2 = 1$.

In matrix form,

$$R_{LV} = \frac{1}{d} \cdot \begin{bmatrix} -y_s & x_s & 0 \\ x_s z_s & y_s z_s & -d^2 \\ -dx_s & -dy_s & -dz_s \end{bmatrix}.$$

The transformation from LV to BC coordinates is accomplished by using the attitude telemetry data. However, since we have found these data to be unusable for our purposes, the LV and BC coordinates are set equal to each other. Thus:

$$\hat{r}_{BC} = \hat{r}_{LV} \quad (4)$$

The transformation of \hat{r}_{BC} into the image frame vector, \hat{r}_{PF} , is

$$\hat{r}_{PF} = (x_{PF}, y_{PF}, z_{PF})^T = R_{PF} \hat{r}_{BC}, \quad (5a)$$

where $R_{PF} = R(\bar{\theta}_p, 2) R(\bar{\theta}_r, 1) R(\bar{\theta}_y, 3)$, (5b)

and $\bar{\theta}_y, \bar{\theta}_r, \bar{\theta}_p$ are the optimized angles resulting from the least-squares navigation technique employing landmark measurements. Since R_{PF} is the transformation from the satellite's body-centered frame to its picture (image) frame, it is expected that this transformation will be reasonably time-independent. The effect of thermal and mechanical stresses on the stability of $\bar{\theta}_y, \bar{\theta}_r, \bar{\theta}_p$ over a period of time on the order of days is something that can only be deduced indirectly by updating the navigation.

With \hat{r}_{PF} determined from equations (5a) and (5b) and adding line and element corrections deduced from earth edges, the satellite image coordinates can be calculated

$$LIN = L_c + (\sin^{-1} y_{PF})/\rho_L + \Delta L_e \quad [PFTOTC] \quad (6a)$$

$$ELE = E_c + (\tan(x_{PF}/z_{PF}))/\rho_E + \Delta E_e \quad \text{and [EDGCOR]} \quad (6b)$$

where,

LIN = line number,

ELE = element number,

ΔL_e = line correction due to attitude shifts,

ΔE_e = element correction due to attitude shifts,

L_c = picture center line = 1200 for visible, 600 for IR ATS-6 image data,

E_c = picture center element = 1200 for ATS-6 image data,

ρ_L = number of radians/line

ρ_E = number of radians/element

} nominal ATS-6 scanned field is $20^\circ \times 20^\circ$.

Summarizing equations (1) - (5),

$$\hat{r}_{PF} = R_{PF} R_{BC} R_{LV} \hat{r}_1, \quad [ES] \quad (7a)$$

$$\text{where } \hat{r}_1 \cdot \|\hat{r}_1\| = \vec{r}_2(t) - \vec{r}_s(t) = R(-\theta_E, 3) \vec{r}_E - \vec{r}_s(t). \quad (7b)$$

Equations (7a) and (7b) effectively define the earth coordinates to satellite image coordinates-transformation.

B. Satellite Image Coordinates to Earth Coordinates (Subroutine SE)

For a given LIN, ELE, it is apparent from equations (6) and Figure 2 that

$$\hat{r}_{PF} = (-\cos \lambda \sin \delta, -\sin \lambda, \cos \lambda \cos \delta)^T \quad [\text{PFTOTC}] \quad (8a)$$

where

$$\lambda = (L_c - \text{LIN} + \Delta L_e) \rho_L = \text{mirror step angle} \quad (8b)$$

$$\delta = (E_c - \text{ELE} + \Delta E_e) \rho_E = \text{mirror sweep angle} \quad (8c)$$

From equation (7a),

$$\hat{r}_1 = R_{LV}^T R_{BC}^T R_{PF}^T \hat{r}_{PF} \quad [\text{SE}] \quad (9)$$

(The three successive transformations in equation (9) are orthogonal matrices; therefore the inverse of each is equal to its transpose).

Now
$$\vec{r} = \vec{r}_s + s \hat{r}_1, \quad (10)$$

where $s = \|\vec{r}_1(t)\|$ equals the distance from the satellite-center to the landmark. The solution of s is achieved by using eq. (10) and the equation of the earth spheroid,

$$(x_E^2 + y_E^2)/r_{eq}^2 + z_E^2/r_p^2 = 1 \quad (11)$$

where,

$$r_{eq} = \text{earth's equatorial radius} = 6378.15 \text{ km},$$

$$r_p = \text{earth's polar radius} = 6356.77 \text{ km},$$

x_E, y_E, z_E are the vector components of the landmark, \vec{r}_E , in the ER frame.

Equations (2), (10) and (11) represent a system of equations of four unknowns (x_E, y_E, z_E, s). The solution of s can easily be accomplished as follows:

Divide the x and y components by r_{eq} and the z component by r_p in (10).

This results in the equation,

$$\vec{r}_2^* = \vec{r}_s^* + s\vec{r}_1^* \quad (12)$$

where,

$$\vec{r}_2^* = R(-\theta_E, 3) \vec{r}_E^* = R(-\theta_E, 3) (x_E/r_{eq}, y_E/r_{eq}, z_E/r_p)^T,$$

$$\vec{r}_1^* = (x_1/r_{eq}, y_1/r_{eq}, z_1/r_p)^T,$$

$$\vec{r}_s^* = (x_s/r_{eq}, y_s/r_{eq}, z_s/r_p)^T.$$

Now $\|\vec{r}_2^*\|^2 = \|R(-\theta_E, 3)\|^2 \cdot \|\vec{r}_E^*\|^2 = 1$, since $R(\theta_E, 3)$ is an orthogonal matrix, and $\|\vec{r}_E^*\|^2$ equals the left side of equation (11). Therefore the equation

$$\|\vec{r}_2^*\|^2 = 1 = \|\vec{r}_s^* + s\vec{r}_1^*\|^2, \quad (13)$$

contains only s as an unknown. The solution of (13), expressed in a form to minimize computational round-off errors, is:

$$s = -(B + \sqrt{\text{RAD}})/2A, \quad (14)$$

where

$$\left. \begin{aligned} \text{RAD} &= B^2 - 4AC, \\ A &= F + (1 - F) z_1^2, \\ B &= 2(x_1 x_s + y_1 y_s) F + 2z_1 z_s, \\ C &= (x_s^2 + y_s^2) F + z_s^2 - r_p^2, \\ F &= r_p^2 / r_{eq}^2. \end{aligned} \right\} \text{[ERTOST]}$$

With the solution of s , it follows from (1) and (10) that

$$\vec{r}_E = R(\theta_E, 3) (\vec{r}_s + s\vec{r}_1) = (x_E, y_E, z_E)^T, \quad \text{[ERTOST]} \quad (15)$$

and hence

$$\theta_L = \tan^{-1}[z_E / ((1 - e^2) \sqrt{x_E^2 + y_E^2})], \quad \text{[ERTOER]} \quad (16a)$$

$$\phi_L = \tan^{-1}[y_E/x_E], \quad [\text{ERTOER}] \quad (16b)$$

where

θ_L = geodetic latitude,

ϕ_L = longitude

$e^2 = (r_{eq}^2 - r_p^2)/r_{eq}^2$ = earth's eccentricity squared.

Equations (9), (15), and (16) constitute the basic - satellite image coordinates to earth coordinates - transformation.

C. Navigation Optimization Procedure (Subroutine ATTTUD)

Navigation of the satellite image data base consists of finding a time dependent transformation to predict the earth coordinates from the associated satellite image coordinates. This is accomplished by using landmark measurements from the data base and the model discussed above to determine the optimal transformation in a least-squares sense. A landmark measurement consists of the earth coordinates, (θ_L, ϕ_L) , the associated image coordinates, (LIN, ELE), and the time, t, at which the landmark was imaged.

Let

α_i = i^{th} parameter to be optimized,

$R_A(\alpha_i)$ = transformation associated with the α_i ,

\hat{r}_k' = unit pointing vector of the k^{th} landmark derived from $(\theta_L, \phi_L)_k$,

\hat{r}_k = unit pointing vector of the k^{th} landmark derived from (LIN, ELE) $_k$,

and

$$S(\alpha_i) = \sum_k \|\hat{r}_k - R_A(\alpha_i) \hat{r}_k'\|^2 \quad [S] \quad (17)$$

which is a sum over all landmark measurements included in the optimization.

The navigation is complete when a set of parameters α_i are found (call

them $\bar{\alpha}_i$) which minimizes S . The optimized values $\bar{\alpha}_i$ are then used in the transformation to predict (θ_L, ϕ_L) from an arbitrary (LIN, ELE).

As an example, consider equation (5a),

$$\text{where} \quad \hat{r}_{PF} = R_{PF} \hat{r}_{BC} \quad [\text{BCTOPF}]$$

and let us assume that the attitude telemetry data is known with a reasonable degree of accuracy but that the orientation of the PF frame relative to the BC frame is not. Thus, we wish to optimize $\theta_y, \theta_r, \theta_p$ in the transformation R_{PF} . Using the landmark measurements and the attitude telemetry data, calculate \hat{r}_{BC} as given by equations (1) to (4a) and \hat{r}_{PF} from equations (8) for each landmark; therefore S in this case takes the form

$$S(\theta_y, \theta_r, \theta_p) = \sum_k \|(\hat{r}_{PF})_k - R_{PF}(\theta_y, \theta_r, \theta_p) (\hat{r}_{BC})_k\|^2, \quad [S]$$

and the values $\bar{\theta}_y, \bar{\theta}_r, \bar{\theta}_p$ which minimize S are the ones then used in equation (5b).

The method used to minimize $S(\alpha_i)$ is an iterative procedure which uses a modified Newton's method.

Let

$\alpha = \{\alpha_i\}$ for convenience,

$\alpha^n =$ value of α resulting from the n^{th} iteration,

$N =$ total number of parameters α_i ,

$H = N \times N$ matrix (Hessian) whose ij^{th} component is $[H]_{ij} = \partial^2 S / \partial \alpha_i \partial \alpha_j$,

$VS =$ gradient of S , $(VS)_i = \partial S / \partial \alpha_i$.

The iterative procedure works as follows:

- 1) Start with $m = 0$ and increase m by 1 until a value M is found such that

$$S(\alpha^n) - S(\alpha^n - 2^{-M} H^{-1} \nabla S(\alpha^n)) \geq (.4) 2^{-M} H^{-1} \nabla S(\alpha^n) \cdot \nabla S(\alpha^n), \quad [\text{LS}]$$

2) When the inequality is satisfied, set

$$\alpha^{n+1} = \alpha^n - 2^{-M} H^{-1} \nabla S(\alpha^n), \quad [\text{MINMIZ}]$$

3) Check to see if the following convergence criteria is met

$$|S(\alpha^{n+1}) - S(\alpha^n)| \leq 10^{-18} |S(\alpha^n)| .$$

If not, set $\alpha^n \leftarrow \alpha^{n+1}$ and go to 1); if yes, then $\alpha^{n+1} = \bar{\alpha}$ and the procedure is finished.

APPENDIX B. ANALYSIS OF METHOD WHICH DETERMINES ATS-6 SSP IMAGE COORDINATE DISPLACEMENTS BETWEEN SUCCESSIVE IMAGES RESULTING FROM ATTITUDE CHANGES

This appendix presents an analysis of the technique used to calculate the ATS-6 Subsatellite Point (SSP) image coordinate changes between successive images resulting from attitude changes during the image-scan time. Appendix C shows how these measurements are used to account for the attitude changes in the process of computing accurate cloud displacements.

1. Method

Let T_1 , T_2 designate two successive ATS-6 data images where T_1 is the "earlier" of the two images and (L_c, E_c) (Line scan and Element numbers) are its SSP image coordinates (Fig. B.1) determined from the ATS-6 navigation model. Let (L, E) be the T_1 image coordinates for a point on the right earth edge and ΔE_R , ΔE_L the measured displacements along line L of the Right and Left T_2 - earth edges relative to the T_1 earth edges. (These measurements are obtained in practice on McIDAS using the infrared ATS-6 data images and an image-matching technique which is constrained to measure displacements of the earth edge only along a scan line. It is worth emphasizing that the image-matching method indeed measures displacements of the geometrical earth edge and not features near it - such as clouds. This is not surprising since the greatest contrast is between earth and space - not within features near the earth's edge.)

The object, then, is to compute the displacement coordinates $(\Delta L, \Delta E)$ of the T_2 -SSP relative to the T_1 - SSP at line L using the measured values of $\Delta E_R, \Delta E_L$.

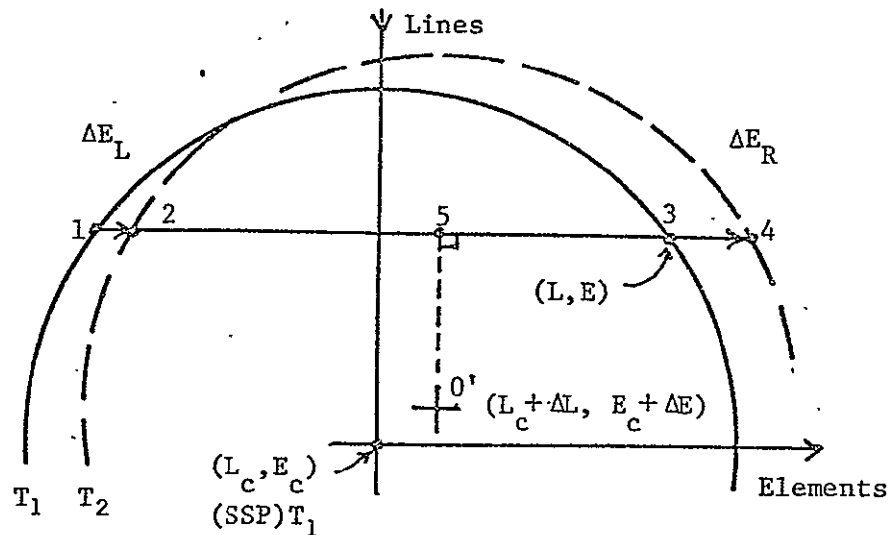

FIGURE B.1. Earth-edge Displacement Measurement Geometry

Let points 1-5 be on line L containing the earth edge points indicated in the figure, and points 0 and 0' the T_1 -SSP and T_2 -SSP. Furthermore, point 5 is the bisect point for the T_2 -chord coinciding with line L, and both T_1 - and T_2 -earth circles have equal radii a .

Letting $\overline{P_i - P_j}$ be the distance (always non-negative) between points i and j , $\Delta L, \Delta E$ can be derived from two simple geometrical identities:

The first is

$$\overline{P_4 - P_5} = \overline{P_5 - P_2}, \text{ or}$$

$$(E + \Delta E_R) - (E_c + \Delta E) = (E_c + \Delta E) - (2E_c - E + \Delta E_L),$$

solving for ΔE ,

$$\Delta E = (\Delta E_R + \Delta E_L)/2. \quad (1)$$

The second identity is

$$\overline{P_4 - P_2} - \Delta E_R = \overline{P_3 - P_1} - \Delta E_L, \text{ where} \quad (2)$$

$$\begin{aligned}
\overline{P_4 - P_2} &= 2 \sqrt{(\overline{P_4 - P_{0'}})^2 - (\overline{P_5 - P_{0'}})^2} \\
&= 2 \sqrt{(\overline{P_3 - P_0})^2 - (\overline{P_5 - P_{0'}})^2} \\
&= 2 \sqrt{(L - L_c)^2 + (E - E_c)^2 - [L - (L_c + L)]^2}, \text{ and} \quad (3)
\end{aligned}$$

$$\overline{P_3 - P_1} = 2(E - E_c). \quad (4)$$

Substitution of (3) and (4) into (2) and rearranging yields

$$\delta = \sqrt{X^2 + Y^2 - (Y - \Delta L)^2} - X, \text{ where} \quad (5)$$

$$\delta = (\Delta E_R - \Delta E_L)/2$$

$$X = E - E_c$$

$$Y = L - L_c.$$

Since δ and (L, E) are obtained from the $\Delta E_R, \Delta E_L$ measurements and a nominal value used for (L_c, E_c) , ΔL can be solved in (5) to yield

$$\Delta L = Y \pm \sqrt{\text{RAD}}, \text{ where} \quad (6)$$

$$\text{RAD} = Y^2 - 2 X \delta - \delta^2.$$

The choice of sign in (6) is determined by substituting the expression for δ in Eq. (5) in RAD; the result is

$$\begin{aligned}
\Delta L &= Y \pm \sqrt{(Y - \Delta L)^2} = Y + \sqrt{\text{RAD}}, Y > \Delta L \\
&= Y - \sqrt{\text{RAD}}, Y < \Delta L. \quad (7)
\end{aligned}$$

The peculiar condition implied by (7) that ΔL must be known before ΔL can be calculated is really not a problem since generally ΔL is small (± 5 lines) and $|Y|$ is usually $\gg |\Delta L|$. For most cases then, the conditions are

$$\Delta L = Y \pm \sqrt{\text{RAD}}, Y \gtrsim 0, \quad (8)$$

$$\text{RAD} = Y^2 - 2 X \delta - \delta^2.$$

For the case where $|Y|$ approaches (ΔL) in value there are other problems; these are discussed at the end of this appendix.

Equations (1) and (8), then, define the displacement in image coordinates of the T_2 -SSP relative to the T_1 -SSP for line L . By repeating this entire process for other scan lines the SSP-shifts $(\Delta L, \Delta E)$ as function of T_1 -line position are obtained. In practice the right and left earth-edge displacements are first measured over the entire range of scan lines of interest. Curves are then separately fit to the right and left edges measurements resulting in a ΔE_R vs L and a ΔE_L vs L curve over the scan-line range of interest. The curve values themselves are then used in (1) and (8) to compute $\Delta L, \Delta E$ curves.

APPENDIX C. ANALYSIS OF ALGORITHM WHICH ACCOUNTS FOR RELATIVE ATTITUDE CHANGES IN SUCCESSIVE ATS-6 DATA IMAGES USING EARTH-EDGE SHIFT MEASUREMENTS

This appendix provides a semi-rigorous analysis of the algorithm used to account for the relative attitude changes in a sequence of ATS-6 data images using the earth-edge measurements derived by the technique discussed in the main portion of the report and APPENDIX B. In effect, this appendix shows why the algorithm "works"; the following appendices discuss in more detail the limitations of and the errors associated with this method.

Consider a sequence of n ATS-6 images designated by T_1, T_2, \dots, T_n , from which the displacements in earth coordinates of a feature (cloud) between successive images are to be determined. Let

(L_i, E_i) = image coordinates (Line, Element) of the cloud feature for the T_i th image,

\hat{r}_{PFi} = $\hat{r}_{PF}(L_i, E_i)$ = unit pointing vector in Picture Frame coordinates derived from (L_i, E_i) using the ATS-6 scan-camera geometry,

\hat{r}_{LVi} = unit Local Vertical pointing vector associated with \hat{r}_{PFi} ,

R_i = 3x3 rotation matrix which transforms without error r_{LVi} into \hat{r}_{PFi} at the time the feature was scanned, i.e.

$$\hat{r}_{PFi} = R_i \hat{r}_{LVi} \quad (1)$$

1. A Two-Image Sequence

Consider now the first two images T_1, T_2 in the sequence whose relationship between LV and PF coordinates are given by

$$\hat{r}_{PF1} = R_1 \hat{r}_{LV1} \quad (2)$$

$$\hat{r}_{PF2} = R_2 \hat{r}_{LV2} \quad (3)$$

ORIGINAL PAGE IS
OF POOR QUALITY

The relationship of the cloud feature in LV coordinates for image T_2 can be related to T_1 as follows:

$$\hat{r}_{LV2} = \hat{r}_{LV1} + \Delta \vec{r}_{LV}(\Delta T_{12}), \quad (4)$$

where $\Delta \vec{r}_{LV}$ is the displacement of the cloud in LV coordinates from T_1 to T_2 and results from two effects:

- (i) apparent change in the earth's orientation over the time interval ΔT_{12} caused by a non-zero angle of inclination in the satellite's orbit (the eccentricity of the ATS-6 orbit was so small ($\sim 10^{-4}$) that no significant change in angular size occurs)

- (ii) motion of the cloud relative to the earth's surface.

Now the orientation of the earth relative to the LV frame depends only on the orbit and the earth's position relative to celestial coordinates; thus if \hat{r}_{LV1} and \hat{r}_{LV2} were accurately known, the displacement of the cloud over the time interval associated with these two vectors could be calculated with an accuracy limited only by the equations describing the dynamical relationship between the satellite orbit and the earth's position relative to celestial coordinates. It is assumed that for ATS-6 that this transformation produces negligible error.

Returning to equations (2) and (3), the rotation matrices R_1 , R_2 differ from each other slightly because of an attitude change of the PF frame relative to the LV frame between T_1 and T_2 ; they are related to each other by an infinitesimal rotation $I + E_{12}$ where I is the unit matrix and E_{12} , an antisymmetric matrix whose elements are the small-angle differences between the PF axes at times T_1 and T_2 . Thus

$$R_2 = (I + E_{12}) R_1 ; \quad (5)$$

substituting (4) and (5) in (3) and expanding

$$\hat{r}_{PF2} = R_1 \hat{r}_{LV1} + E_{12} R_1 \hat{r}_{LV1} + R_1 \Delta \vec{r}_{LV} (\Delta T_{12}) + E_{12} R_1 \Delta \vec{r}_{LV} (\Delta T_{12}) \quad (6)$$

The first term on the RHS of (6) is \hat{r}_{PF1} , the last term is negligible ($\sim 10^4$ times smaller than the first order terms), the second term is the change in PF coordinates due to an attitude change and the third term is the change in PF coordinates due to the two changes in the LV frame discussed above. Using (4) to combine the first and third terms, equation (6) then can be rewritten as

$$\hat{r}_{PF2} = R_1 \hat{r}_{LV2} + E_{12} \hat{r}_{PF1} . \quad (7)$$

Comparison of (7) with (2) implies that if E_{12} and R_1 were known, \hat{r}_{LV1} and \hat{r}_{LV2} - and therefore the cloud displacement - could be computed with a high degree of accuracy.

A good approximation to E_{12} is obtained from the earth-edge displacement measurements which provide the displacement in image coordinates $\Delta L_{12}(L)$, $\Delta E_{12}(L)$ of T_2 relative to T_1 as a function of line number L . The line shift ΔL_{12} is proportional to a small change in roll ΔR_{12} about the PF-X axis and the element shift is proportional to small changes in pitch ΔP_{12} about the PF-Y axis, i.e.

$$\Delta L_{12} = \Delta R_{12} / \rho , \quad (8a)$$

$$\Delta E_{12} = \Delta P_{12} / \rho , \quad (8b)$$

where ρ is the angular size of a pixel = 1.45×10^{-4} radians.

Letting $\hat{r}_{PF1} = [X, Y, Z]^T$ where T is the transpose, the explicit form of E_{12} and the last term in (7) is

$$\begin{aligned}
 E_{12} \hat{r}_{PF1} &= \begin{bmatrix} 0 & 0 & \Delta P \\ 0 & 0 & \Delta R \\ -\Delta P & -\Delta R & 0 \end{bmatrix} \begin{bmatrix} X \\ Y \\ Z \end{bmatrix} \\
 &= [\Delta P Z, \Delta R Z, -(\Delta P X + \Delta R Y)]^T, \tag{9}
 \end{aligned}$$

where it is understood that ΔR , ΔP refer to the T_1 to T_2 changes in attitude at the times the cloud was scanned.

Note E_{12} contains no non-zero yaw angle element (small rotation about the axis passing through the image SSP) since there is no way that the earth-edge displacement measurement technique can provide this angle; however, the analysis given in Appendix E of reference 3 shows that the effect on the accuracy of wind measurements (displacements) for yaw changes is generally small. Analysis of landmark measurements and the ATS-6 wind sets shown in this report, indicate that for the data images studied thus far, the yaw changes are negligible.

With E_{12} and hence the last term in (7) determined, equation (7) can be rewritten as

$$\hat{r}'_{PF2} = \hat{r}_{PF2} - E_{12} \hat{r}_{PF1} = R_1 \hat{r}_{LV2}, \tag{10}$$

where \hat{r}'_{PF2} is interpreted as the T_2 cloud pointing vector with the attitude changes removed.

2. Computing \hat{r}'_{PF2} in Practice

Cloud displacement measurements and computation of \hat{r}'_{PF2} is accomplished as follows:

- (1) the T_1 image coordinates (L_1, E_1) of the cloud are recorded,

- (2) the total displacement of the cloud in image coordinates $(\Delta L^T, \Delta E^T)$ from T_1 to T_2 are measured on McIDAS using an image matching technique,
- (3) from previously determined earth-edge displacement parameters, the displacement coordinates $\Delta L_{12}, \Delta E_{12}$ due to relative attitude changes are computed and subtracted from $\Delta L^T, \Delta E^T$. These differences are added to L_1, E_1 and the associated PF vector computed. That this vector is a good approximation of \hat{r}_{PF2} is shown below.

By definition,

$$\hat{r}_{PF1} = \hat{r}_{PF}(L_1, E_1) \quad (11)$$

$$\hat{r}_{PF2} = \hat{r}_{PF}(L_1 + \Delta L^T, E_1 + \Delta E^T) = \hat{r}_{PF}(L_2, E_2) \quad (12)$$

Expanding $\hat{r}_{PF}(L_1 + \Delta L^T - \Delta L_{12}(L_2), E_1 + \Delta E^T - \Delta E_{12}(L_2))$ about $(L_1 + \Delta L^T, E_1 + \Delta E^T)$ keeping first order terms, we have

$$\hat{r}_{PF}(L_1 + \Delta L^T, E_1 + \Delta E^T) - \frac{\partial}{\partial L} \hat{r}_{PF}(L_2, E_2) \Delta L_{12} - \frac{\partial}{\partial E} \hat{r}_{PF}(L_2, E_2) \Delta E_{12} \quad (13)$$

From the geometry of the ATS-6 scan-camera,

$$\begin{aligned} \hat{r}_{PF} &= [-\cos\lambda \sin\delta, -\sin\lambda, \cos\lambda \cos\delta]^T \\ &= [X, Y, Z]^T \end{aligned} \quad (14)$$

where

$$\lambda = (L_c - L)\rho = \text{mirror step angle,}$$

$$\delta = (E_c - E)\rho = \text{mirror sweep angle,}$$

$$(L_c, E_c) = \text{image center line and element value,}$$

$$\rho = \text{angular size of a line or element.}$$

Taking the partials of \hat{r}_{PF} in (14) with respect to L,E, and retaining first order terms with the partials evaluated at (L_2, E_2) :

$$\begin{aligned} & \frac{\partial}{\partial L} \hat{r}_{PF} \Delta L_{12} + \frac{\partial}{\partial E} \hat{r}_{PF} \Delta E_{12} \\ & = [0, PZ, -PY]^T \Delta L_{12} + [PZ, 0, -PX]^T \Delta E_{12}, \end{aligned} \quad (15)$$

substituting (8a) and (8b) into the above expression and adding the two vectors in (15) yields

$$[Z\Delta P_{12}, Z\Delta R_{12}, - (X\Delta P_{12} + Y\Delta R_{12})]^T,$$

which is equivalent to (9); therefore (15) is the same as $E_{12} \hat{r}_{PF1}$. Since the first term in (13) is \hat{r}_{PF2} , we have

$$\begin{aligned} & \hat{r}_{PF}(L_1 + \Delta L^T - \Delta L_{12}(L_2), E_1 + \Delta E^T - \Delta E_{12}(L_2)) = \\ & \hat{r}_{PF2} - E_{12} \hat{r}_{PF} = \hat{r}'_{PF2} \quad \text{by} \end{aligned} \quad (16)$$

comparison with (10). Thus the method discussed above correctly yields \hat{r}'_{PF2} .

3. Transforming PF to LV coordinates

With the attitude changes between T_1 and T_2 removed, we have

$$\hat{r}_{PF1} = R_1 \hat{r}_{LV1} \quad (17)$$

$$\hat{r}'_{PF2} = R_1 \hat{r}_{LV2} \quad (\text{see (10)}) \quad (18)$$

Let \bar{R} be the transformation from LV to PF coordinates derived from T_1 landmark measurements in a least squares sense assuming a constant attitude over the time interval the T_1 landmarks were scanned, i.e. \bar{R} is a constant matrix. \bar{R} then will differ slightly from R_1 due to small

attitude changes over the T_1 scan time and, in addition, will differ from R_1 (assumed to be the error-free transformation) due to mirror scan nonlinearities. Similarly, as above, we can relate \bar{R} to R_1 by an infinitesimal transformation

$$\bar{R} = R_1 (I - e), \quad (19)$$

where e is the infinitesimal antisymmetric error matrix which is a function of line and element. It is important to realize that the elements of e contain absolute errors which the ATS-6 model cannot account for.

However, our previous work using landmark measurements has provided us with bounds on these errors and the rate at which they change as a function of image coordinates. The worst-case estimates correspond to about ± 2.5 pixels ($\pm 3.6 \times 10^{-4}$ radians). The errors tend to be oscillatory as a function of line or element position with a period of 100 to 200 pixels. Thus for typical feature displacement measurements (corresponding to tens of pixels), e can be considered to be a constant locally. (It would be appropriate to remind the reader at this point that the absolute mirror scan nonlinearities as a function of image coordinates repeat from image to image.)

Taking the transpose of (19) and operating on (17) and (18)

$$\hat{r}'_{LV1} = \bar{R}^T \hat{r}_{PF1} = (I + e) R_1^T R_1 \hat{r}_{LV1} = \hat{r}_{LV1} + \vec{r}_e \quad (20a)$$

$$\hat{r}'_{LV2} = \bar{R}^T \hat{r}'_{PF2} = (I + e) R_1^T R_1 \hat{r}_{LV2} = \hat{r}_{LV2} + \vec{r}_e, \quad (20b)$$

where

$$\vec{r}_e = e \hat{r}_{LV}. \quad (21)$$

Application of \bar{R} then, results in the correct LV vectors to within the same additive vector constant. It is shown in Appendix C of reference 3 that this constant has a negligible effect in computing cloud velocities or displacements.

In addition location errors on the earth due to \vec{r}_e is given in this appendix.

4. General Case of n-image Sequence

The case for images T_1, T_2, \dots, T_n is simply a generalization of the 2-image case. The error-free LV to PF frame matrix for T_i can be related to R_1 by the image pair relative-attitude transformation matrices $E_{i,i+1}$ where

$$\begin{aligned} R_n &= (I + E_{n-1,n}) \cdots (I + E_{2,3})(I + E_{1,2})R_1 \\ &= \left(I + \sum_{i=1}^{n-1} E_{i,i+1} \right) R_1, \end{aligned} \quad (22)$$

where only first order terms are retained. Thus the analog to (10), generalized to n images, is

$$\hat{r}'_{PFn} = \hat{r}_{PF} - \left(\sum_{i=1}^{n-1} E_{i,i+1} \right) \hat{r}_{PF1} = R_1 \hat{r}_{LVn},$$

where in practice \hat{r}'_{PFn} is computed by evaluating the expression

$$\hat{r}'_{PFn} = \hat{r}_{PF} \left(L_n - \sum_{i=1}^{n-1} \Delta L_{i,i+1}(L_{i+1}), E_n - \sum_{i=1}^{n-1} \Delta E_{i,i+1}(L_{i+1}) \right) \quad (23)$$

where $L_{i,i+1}(L_{i+1})$, $E_{i,i+1}(L_{i+1})$ are evaluated from the T_i to T_{i+1} earth-edge displacement measurements evaluated at L_{i+1} , where L_{i+1} is the T_{i+1} line number of the "center of gravity" of the feature being tracked.

Application of (19) to the \hat{r}'_{PFi} results in

$$\hat{r}'_{LVi} = \hat{r}_{LVi} + \vec{r}_e \quad i = 1, 2, \dots, n. \quad (24)$$

ORIGINAL PAGE IS
OF POOR QUALITY

APPENDIX D. METHOD OF OBTAINING MIRROR-SCAN-OFFSET CORRECTION CURVES

The nature of the mirror-scan nonlinearity problem has been discussed in previous reports. In order to correct the alternate scan offset caused by this effect, we need a table of offset values as a function of element number (i.e. a $\Delta E(E)$ function). For our initial efforts to produce a $\Delta E(E)$ function, we used the McIDAS cloud-tracking program to measure the displacement of a feature seen in the odd number scans of an image to its position in the even numbered scans of the same image. The method described here is a somewhat more automated scheme and does not require viewing the ATS-6 images. The method has been applied to an IR image (74195 173134Z) and gives good agreement with the old method with less scatter of individual points about a polynomial least-squares fit curve (Fig. D.1.).

In the automated method of computing the $\Delta E(E)$ function a correlation value is computed for the match between a small segment of an odd scan and a shifted segment of an adjacent even scan. The amount of shift which gives the best correlation for that small line segment is taken to be the ΔE value for that scan line and element location. Values are computed over many scans and elements, then averaged over the scans. The result is a table of ΔE values as a function of $E(\text{element})$. The table values are then smoothed by using a least squares fit polynomial. In more detail the method is as follows:

Let:

$e = \text{element number } (1 \leq e \leq 2400)$

$s = \text{scan number } (1 \leq s \leq 1200)$

$p_e(s,e) = \text{pixel digital value at a given even-scan, element position}$

$p_o(s,e)$ = pixel digital value at a given odd-scan, element position

δ = an element shift value

t = a small number defining the length of the scan segment used for a correlation

$C(s,e,\delta)$ = a measure of the match between line segments from adjacent odd and even scans.

Now define C by:

$$C(s,e,\delta) = \sum_{e'=e-t}^{e+t} [p_o(s,e') - p_e(s+1, e'+\delta)]^2 \quad (s \text{ odd})$$

The element shift, ΔE , for a given point on the image (s,e) is the value of δ that gives a minimum value to C :

$$C(s,e,\Delta E(s,e)) \leq C(s,e,\delta) \quad \text{for all values of } \delta$$

After an array of these values is generated, a weighted average over scans is taken:

$$\Delta E(e) = \frac{\sum_S w(s,e)\Delta E(s,e)}{\sum_S w(s,e)}$$

The weighting factor is the range of brightness values from the odd scan used in computing C .

$$w(s,e) = \text{MAX}(p_o(s,e')) - \text{MIN}(p_o(s,e'))$$

where $e - t \leq e' \leq e + t$.

The reason for using this weighting is simply that high contrast features should, in general, produce a correlation value of more significance than features of nearly uniform brightness.

The computer program to do this used the values: $t = 7$ and $+4 \leq \delta \leq 12$. Values of $\Delta E(s,e)$ were computed for every eight scans for the middle third of the image ($s = 399, 407, \dots, 799$) and for every 10 elements across most of the width of the image ($e = 100, 110, \dots, 2300$). Using this line and element range some ΔE values will be computed for points off the earth. When off-earth and on-earth points are averaged together the weighting factor will give only a very small or zero weighting to the off-earth points. For some element values no on-earth points are encountered. We found that these points could be determined from the table of $\Delta E(e)$ values. There is a discontinuity between the on-earth and off-earth values.

The $\Delta E(e)$ function is then used to create a corrected image by shifting even scans. An improved method of correcting the alternate scan offset has also been developed. In the old method a fixed shift value was used across the width of a McIDAS image (672 pixels). Although this gave fairly good results, there could be a one or two element alignment error near the edges of the image. The new method, as before, uses the odd scans as a fixed reference. However, the required amount of shift is computed, or looked up in a table, for each pixel in the even scans. Thus the amount of shift varies from one side of the image to the other. Pixels are dropped or doubled, as appropriate, between regions of different shift values.

ALTERNATE SCAN OFFSET. ATS-6 IR 74195 173134Z.

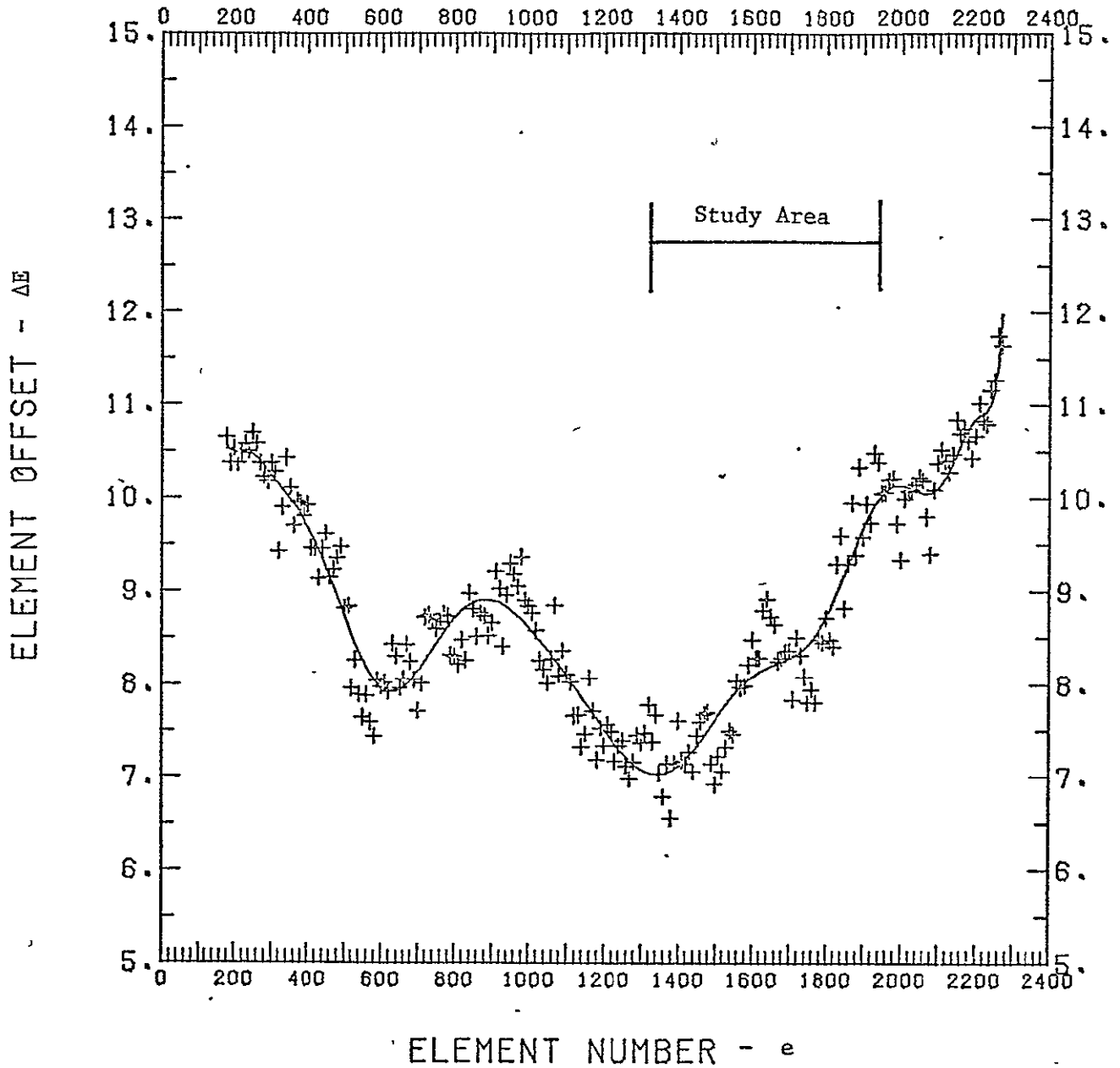

FIGURE D.1. Mirror-Scan Nonlinearity Curve $\Delta E(e)$ using newly developed procedure.

ORIGINAL PAGE IS
OF POOR QUALITY

Appendix E-

Source Code Listings (FORTRAN) of Programs and Subroutines

This appendix contains FORTRAN source listings for the main programs and subroutines for the ATS-6 image correction and navigation system. For main programs both AOIPS and McIDAS versions are given. For subroutines only the McIDAS version is given as the AOIPS version would be identical.

ATSF2/AOIPS

```

DIMENSION MIN(10)
711  FORMAT(///// '   ***  ATS 6  PROCESSING  ***')
712  FORMAT( 74H      1  INITIALIZE NAVCOM                               )
*
713  FORMAT( 74H      2  GENERATE ELEMENT OFFSET DATA FROM E.H.T.      )
*
714  FURMAT( 74H      3  CURVE FIT TO OFFSET DATA                       )
*
715  FORMAT( 74H      4  READ IMAGE SEGMENT FROM E.H.T.                 )
*
716  FURMAT( 74H      5  CURVE FIT TO EARTH EDGE DATA                  )
*
717  FORMAT( 74H      6  RUN NAVIGATION                                  )
*
718  FURMAT( 74H      7  EXIT AFS6 PROCESSING                             )
*
IT=5
WRITE(IT,711)
WRITE(IT,712)
WRITE(IT,713)
WRITE(IT,714)
WRITE(IT,715)
WRITE(IT,716)
WRITE(IT,717)
WRITE(IT,718)
NL=8
MENU=1
CALL INCOM(' ',0,NL,1,MIN,MENU,1,1)
IF(MENU.LE.0) GO TO 990
IJ=MIN(1)
GO TO (1,2,3,4,5,6,7),IJ
1  CALL REQUES(RAD50('A6INT2'))
GO TO 999
2  CALL REQUES(RAD50('OFSTG2'))
GO TO 999
3  CALL REQUES(RAD50('OFSTF2'))
GO TO 999
4  CALL REQUES(RAD50('LATS2'))
GO TO 999
5  CALL REQUES(RAD50('EDGFT2'))
GO TO 999
6  CALL REQUES(RAD50('ATSNV2'))
GO TO 999
7  CALL REQUES (RAD50('MET2'))
GO TO 999
990 CONTINUE
CALL REQUES(RAD50('MET2'))
999 CONTINUE
END.

```

ORIGINAL PAGE IS
OF POOR QUALITY

ATSNV/AOIPS

```

C   PROGRAM TO NAVIGATE AT56 IMAGES FROM LANDMARKS.
      INTEGER*4 ILAT,ILON,LYD,ITIME
      DIMENSION PTIME(150),ALIN(150),AELE(150),ALAT(150),ALON(150)
      DIMENSION IFIME(150),ILIN(150),IELE(150),ILAT(150),ILON(150),ICODE
*(150)
      DIMENSION MIN(10),MOUT(24)
      COMMON/NAVCOM/NAVN,INAV,IYR,IDAY,TOTLIN,DEGLIN,TOTIEL,DEGELE,PICLI
*N,PICLE,IMPSC,LOYR,IODAY,IM,KIX,RIX,RIZ,RIDY,RIDZ,PITCH,ROL
*L,YAW,P1IM(3),TMN(3),IMX(3),NLCOEF(2),NRCOEF(2),SCLLO(2),SCLLI(2),
*ELCOEF(11,2),SCLRO(2),SCLRI(2),ERCOEF(11,2),NASCEF,SCLAS0,SCLAS1,
*IELEMN,IELEMX,ASCDEF(16)
      DATA P1/3.1415926535/
      DATA IT/57,LP/67
      RADDEG=P1/180.0
      LUN=10
      OPEN(UNIT=LUN,NAME='DB0:(350,62)A6LMKS.DAT',TYPE='OLD',READONLY)
2    CONTINUE
      NL=0
10   CONTINUE
      NL=NL+1
      READ(LUN,730,END=40)IYD,ITIME(NL),ICODE(NL),ILIN(NL),IELE(NL),ILAT
*(NL),ILON(NL)
730  FORMAT(2X,8I9)
      GO TO 10
40   CONTINUE
      NL=NL-1
      CLOSE(UNIT=LUN)
      KC=2HDL
      DO 50 I=1,NL
      WRITE(LP,708)ITIME(I),ICODE(I),ILIN(I),IELE(I),ILAT(I),ILON(I)
708  FORMAT(1X,8I9)
50   CONTINUE
51   CONTINUE
      WRITE(IT,706)IDAY,NL
706  FORMAT(1X,'DAY=',I5,' NUMBER OF LANDMARKS=',I3)
      NLMK=0
      DO 100 I=1,NL
      IF(MOD(ICODE(I)/100,10).NE.0) GO TO 100
      NLMK=NLMK+1
      PTIME(NLMK)=FTIME(ITIME(I))
      ALIN(NLMK)=FLOAT(ILIN(I))
      AELE(NLMK)=FLOAT(IELE(I))
      ALAT(NLMK)=FLVAL(ILAT(I))
      ALON(NLMK)=FLVAL(ILON(I))
      WRITE(LP,780)PTIME(NLMK),ALIN(NLMK),AELE(NLMK),
*(ALAT(NLMK),ALON(NLMK)
780  FORMAT(1X,6F15.5)
100  CONTINUE
      CLOSE(UNIT=LP)
      IF(NLMK.LE.0) GO TO 990
      CALL AITUD(PTIME,ALIN,AELE,ALAT,ALON,NLMK)
      PD=PITCH/RADDEG
      RD=ROLL/RADDEG

```

ORIGINAL PAGE IS
OF POOR QUALITY

ATSNV/AOIPS

```

ID=YAW/RADDEG
WRITE(11,701)PD,RO,ID
701  FORMAT(1H0,1X,'PLFCH=',E16.9,' ROLL=',E16.9,' YAW=',E16.9)
195  CONTINUE
      DO 200 I=1,NL
      PFM=FTIME(I)IME(I)
      XLA=FLALO(LAL(I))
      XLO=FLALO(LON(I))
      CALL ES(PFM,XLA,XLO,XLIN,XELE)
      RLIN=LLIN(I)-XLIN
      RELE=LELE(I)-XELE
      WRITE(LP,710)IFIME(I),ICODE(I),RLIN,RELE
200  CONTINUE
201  CONTINUE
710  FORMAT(3X,16,5X,15,5X,2F10.2)
      GO TO 999
990  CONTINUE
999  CONTINUE
      CALL REQUES(RAD50('ATSF2'))
      END

```

***** ATSNV/MCIDAS *****

```

@ELT,L AF.ATSNV/MCIDAS
ELT007_RLIB62 12/22-17:01:39-(0,)
000001 000 $JOB ATSNV U3200
000002 000 $OPTION .8,9,20
000003 000 $FORTRAN
000004 000 SUBROUTINE MAIN
000005 000 C PROGRAM TO NAVIGATE ATS6 IMAGES FROM LANDMARKS.
000006 000 LOGICAL OPTION
000007 000 INTEGER POS,GLEB
000008 000 EQUIVALENCE (ICOM,NAVN)
000009 000 DIMENSION ICOM(1)
000010 000 DIMENSION PTIME(150);ALIN(150),AELE(150),ALAT(150),ALON(150)
000011 000 DIMENSION ITIME(150),ILIN(150),IELE(150),ILAT(150),ILON(150),ICODE
000012 000 *(150)
000013 000 DIMENSION MSQ(10)
000014 000 DIMENSION MIN(10),MOUT(24)
000015 000 DIMENSION GLEB(672)
000016 000 COMMON/NAVCOM/NAVN,INAV,IYR,IDAY,TOTLIN,DEGLIN,TOTIEL,DEGELE,PICLI
000017 000 *N,PICELE,TMPSCL,IYR,IODAY,TM,R1X,R1Y,R1Z,R1DX,R1DY,R1DZ,PITCH,ROL
000018 000 *L,YAW,PTIM(3),TMN(3),TMX(3),NLCOEF(2),NRCOEF(2),SCLLO(2),SCLL1(2),
000019 000 *ELCOEF(11,2),SCLRO(2),SCLR1(2),ERCOEF(11,2),NASCEF,SCLAS0,SCLAS1,
000020 000 *IELEMN,IELEMN,ASCOEF(16)
000021 000 DATA PI/3.1415926535/
000022 000 DATA MSQ/6HDEFATD,8*0/
000023 000 DATA ICODE/150*0/
000024 000 DATA MIN/6HATSNV,8*0/
000025 000 CALL IQ(MIN)
000026 000 NDAY=MIN(1)
000027 000 JOUT=1
000028 000 IF(OPTION(MIN(4),3H P)) JOUT=2
000029 000 IF(.NOT.OPTION(MIN(2),3H A).AND..NOT.(MIN(2).EQ.0 ))GO TO 195
000030 000 IPT1=MIN(5)
000031 000 IPT2=MIN(6)
000032 000 IPT3=MIN(7)
000033 000 NAVDAY=MOD(NDAY,100000)
000034 000 ISS=NDAY/100000
000035 000 ISS=(ISS/2)*2
000036 000 KDAY=ISS*100000+NAVDAY
000037 000 RADDEG=PI/180.0
000038 000 IF(MIN(5).NE.3HNEW) GO TO 2
000039 000 DO 3 I=1,203
000040 000 3 ICOM(I)=0
000041 000 CALL WCOM
000042 000 2 CONTINUE
000043 000 CALL GETNAV(KDAY,IEXIST)
000044 000 IF(IPT1.NE.0)PTIM(1)=FTIME(IPT1)
000045 000 IF(IPT2.NE.0)PTIM(2)=FTIME(IPT2)
000046 000 IF(IPT3.NE.0)PTIM(3)=FTIME(IPT3)
000047 000 IF(IEXIST.GE.10)GO TO 990
000048 000 CALL HEDDER(KDAY,GLEB,POS)
000049 000 IF(GLEB(POS+1).NE.KDAY.OR.GLEB(POS+2).LT.0)GO TO 990
000050 000 INDEX=6*GLEB(POS+2)+88
000051 000 NL=0
000052 000 10 CALL SCRA(30,INDEX)
000053 000 CALL READW(30,672,GLEB)
000054 000 DO 30 I=1,661,6
000055 000 KIND=GLEB(I)/100000
```

ORIGINAL PAGE IS
OF POOR QUALITY

***** ATSNV/MCIDAS *****

```
000056      000      IF(KIND.EQ.0) GO TO 40
000057      000      IF(KIND.NE.1) GO TO 30
000058      000      IF(NL.GE.150) GO TO 30
000059      000      NL=NL+1
000060      000      ITIME(NL)=GLEB(I+1)
000061      000      ICODE(NL)=MOD(GLEB(I),100000)
000062      000      ILIN(NL)=GLEB(I+2)
000063      000      IELE(NL)=GLEB(I+3)
000064      000      ILAT(NL)=GLEB(I+4)
000065      000      ILON(NL)=GLEB(I+5)
000066      000      30      CONTINUE
000067      000      JJ=GLEB(672)
000068      000      IF(JJ.LT.0) GO TO 40
000069      000      INDEX=6*JJ+88
000070      000      GO TO 10
000071      000      40      CONTINUE
000072      000      KC=2HDL
000073      000      IF(.NOT.OPTION(MIN(3),3H L)) GO TO 51
000074      000      DO 50 I=1,NL
000075      000      ENCODE(132,708,MOUT)KC,NDAY,ITIME(I),ICODE(I),ILIN(I),IELE(I),
000076      000      *ILAT(I),ILON(I)
000077      000      CALL TP(JOUT,MOUT)
000078      000      708      FORMAT(1X,A2,8I9)
000079      000      50      CONTINUE
000080      000      51      CONTINUE
000081      000      ENCODE(132,706,MOUT)IDAY,NL
000082      000      CALL TP(JOUT,MOUT)
000083      000      706      FORMAT(1X,'DAY=',I5,' NUMBER OF LANDMARKS=',I3)
000084      000      NLMK=0
000085      000      DO 100 I=1,NL
000086      000      IF(MOD(ICODE(I)/100,10).NE.0) GO TO 100
000087      000      NLMK=NLMK+1
000088      000      PTIME(NLMK)=FTIME(ITIME(I))
000089      000      ALIN(NLMK)=FLOAT(ILIN(I))
000090      000      AELE(NLMK)=FLOAT(IELE(I))
000091      000      ALAT(NLMK)=FLALO(ILAT(I))
000092      000      ALON(NLMK)=FLALO(ILON(I))
000093      000      100      CONTINUE
000094      000      IF(NLMK.LE.0) GO TO 990
000095      000      CALL ATTTUD(PTIME,ALIN,AELE,ALAT,ALON,NLMK)
000096      000      PD=PITCH/RADDEG
000097      000      RD=ROLL/RADDEG
000098      000      YD=YAW/RADDEG
000099      000      ENCODE(132,701,MOUT)PD,RD,YD
000100      000      CALL TP(JOUT,MOUT)
000101      000      701      FORMAT(1H0,1X,'PITCH=',E16.9,' ROLL=',E16.9,' YAW=',E16.9)
000102      000      CALL WCOM
000103      000      MSQ(3)=KDAY
000104      000      MSQ(4)=ILALO(PD)
000105      000      MSQ(5)=ILALO(RD)
000106      000      MSQ(6)=ILALO(YD)
000107      000      CALL SQ(MSQ)
000108      000      195      CONTINUE
000109      000      IF(.NOT.OPTION(MIN(2),3H R).AND..NOT.(MIN(2).EQ.0 ))GO TO 201
000110      000      CALL GETNAV(KDAY,IEXIST)
000111      000      DO 200 I=1,NL
000112      000      PTM=FTIME(ITIME(I))
```

***** ATSNV/MCIDAS *****

```
000113      000      XLA=FLALO(ILAT(I))
000114      000      XLO=FLALO(ILON(I))
000115      000      CALL ES(PTM,XLA,XLO,XLIN,XELE)
000116      000      RLIN=ILIN(I)-XLIN
000117      000      RELE=IELE(I)-XELE
000118      000      ENCODE(132,710,MOUT)ITIME(I),ICODE(I),RLIN,RELE
000119      000      CALL TP(JOUT,MOUT)
000120      000      200      CONTINUE
000121      000      201      CONTINUE
000122      000      710      FORMAT(3X,I6,5X,15,5X,2F10.2)
000123      000      RETURN
000124      000      990      CONTINUE
000125      000      CALL EMESS(3HREQ,NDAY)
000126      000      RETURN
000127      000      ENDS
000128      000      $FILEMA
000129      000      DELETE ATSNV, GORP
000130      000      $INCLUDE HEDDER
000131      000      $CATALOG
000132      000      NAME=ATSNV,S,R,W,D
000133      000      TYPE=FG
000134      000      LIB=ATSF LB,LL
000135      000      BEGIN
000136      000      $EJECT
```

END ELT.

@HDG,P ***** ATTTUD *****

***** ATTUD/MCIDAS *****

@ELT,L AF.ATTUD/MCIDAS

ELT007 RLIB62 12/22-17:01:41-(0,)

```
000001 000 SUBROUTINE ATTUD(PTIME,ALIN,AELE,ALAT,ALON,NLMK)
000002 000 C SUBROUTINE TO COMPUTE AT56 ATTITUDE FROM LANDMARKS.
000003 000 C YAW, PITCH, AND ROLL VALUES FOR A SMALL OFFSET OF THE PICTURE
000004 000 C FRAME COORDINATES FROM BODY CENTERED COORDINATE SYSTEM.
000005 000 C 7 JUNE 1977 G. C. CHATTERS
000006 000 DIMENSION PTIME(1),ALIN(1),AELE(1),ALAT(1),ALON(1)
000007 000 DIMENSION X(3,150),Y(3,150),TIME(150),PRY(3)
000008 000 COMMON/NAVCOM/NAVN,INAV,IYR,IDAY,TOTLIN,DEGLIN,TOTIEL,DEGELE,PICLI
000009 000 *N,PICELE,TMPSC1,I0YR,J0DAY,TM,R1X,R1Y,R1Z,R1DX,R1DY,R1DZ,PITCH,ROL
000010 000 *L,YAW,PTIM(3),TMN(3),TMX(3),NLCOEF(2),NRCOEF(2),SCLLO(2),SCLL1(2),
000011 000 *ELCOEF(1,2),SCLRO(2),SCLR1(2),ERCOEF(1,2),NASCEF,SCLAS0,SCLAS1,
000012 000 *IELEMN,IELEMX,ASCOEF(16)
000013 000 COMMON/MINCOM/X,Y,TIME,NP
000014 000 DIMENSION MOUT(24)
000015 000 DATA PI/3.14159265/
000016 000 DATA LP/6/
000017 000 KDPDG=PI/180.0
000018 000 RADLIN=RDPDG*DEGLIN/TOTLIN
000019 000 RADELE=RDPDG*DEGELE/TOTIEL
000020 000 NP=NLMK
000021 000 DO 100 I=1,NLMK
000022 000 ISCAN=1200-(IFIX(ALIN(I))-1)/2
000023 000 TIME(I)=PTIME(I)+ISCAN*TMPSC1
000024 000 IDIR=1
000025 000 C CONVERT LAT , LON TO ROTATING EARTH CO-OR
000026 000 CALL ERTOR(ALAT(I),ALON(I),X1ER,X2ER,X3ER,IDIR)
000027 000 C CONVERT ROTATING EARTH TO INERTIAL EARTH COORDINATES
000028 000 CALL ERTOST(X1ER,X2ER,X3ER,X1,X2,X3,IDIR,TIME(I))
000029 000 C EARTH INERTIAL TO SATELLITE LOCAL VERTICAL
000030 000 CALL STTOLV(X1,X2,X3,IDIR,TIME(I))
000031 000 C NOTE:ATTITUDE DATA NOT USED THUS LOCAL VERTICAL SAME AS BODY CENTE
000032 000 X(1,I)=X1
000033 000 X(2,I)=X2
000034 000 X(3,I)=X3
000035 000 100 CONTINUE
000036 000 DO 200 I=1,NLMK
000037 000 ELEANG=(PICELE-AELE(I))*RADELE
000038 000 ALNANG=(PICLIN-ALIN(I))*RADLIN
000039 000 Y(1,I)=-SIN(ELEANG)*COS(ALNANG)
000040 000 Y(2,I)=-SIN(ALNANG)
000041 000 Y(3,I)=COS(ELEANG)*COS(ALNANG)
000042 000 200 CONTINUE
000043 000 PRY(1)=0.
000044 000 PRY(2)=0.
000045 000 PRY(3)=0.
000046 000 CALL MINMIZ(PRY,PRY,GNORM,VALUE,ITER)
000047 000 PITCH=PRY(1)
000048 000 ROLL=PRY(2)
000049 000 YAW=PRY(3)
000050 000 ENCCDE(132,702,MOUT)ITER,GNORM,VALUE
000051 000 702 FORMAT(1H0,5X,'CONVERGENCE AT ITERATION',I6,'//0X,'GRADIENT NORM=',
000052 000 *E16.9,' S FINAL VALUE=',E16.9)
000053 000 CALL TQ(MOUT)
000054 000 RETURN
000055 000 ENDS
```

ORIGINAL PAGE IS
OF POOR QUALITY

A6INT/AOIPS

```

INTEGER*4 ITIME
DIMENSION MIN(10),RMIN(10),R1(3),R2(3)
COMMON/NAVCOM/NAVW,INAV,IYR,IDAY,FOPLIN,DEGLIN,TOTIEL,DEGELE,PICLI
* N,PICELE,TMPSCU,IYR,UDAY,IM,R1X,R1Y,R1Z,R1DX,R1DY,R1DZ,PITCH,ROU
* L,YAW,PIIM(3),IMN(3),IMX(3),NLCOEF(2),NRCOEF(2),SCLLO(2),SCLL1(2),
* ELCOEF(11,2),SCLRO(2),SCLR1(2),ERCOEF(11,2),NASCEF,SCLAS0,SCLAS1,
* IELEMN,IELEMX,ASCDEF(16)
DATA P1/3.1415926535/
DATA LP/6/
C PROGRAM TO INITIALIZE ATS 6 NAVCOM
RADDEG=P1/180.0
MENU=1
CALL INCOM(' NAVCOM TO BE PRINTED? (1=YES, DEFAULT=NO)',42,1,1,MIN
*,MENU,1,1)
IF(MENU.LE.0) GO TO 999
JPRI=MIN(1)
MENU=1
CALL INCOM(' ENTER DAY NUMBER',17,1,1,MIN,MENU,1,1)
IF(MENU.LE.0) GO TO 999
INAV=1111
TUPLIN=2400.0
DEGLIN=19.92
TOTIEL=2400.0
DEGELE=20.07
PICLIN=(TOTLIN+1.0)/2.0
PICELE=(TOTIEL+1.0)/2.0
TMPSCU=0.02
IYR=74
IDYR=74
IDAY=MIN(1)
IDDAY=IDAY
MENU=3
CALL INCOM(' ENTER 3 PICTURE START TIMES - HHMMSS',37,1,1,RMIN,MEN
* U,3,1)
IF(MENU.LE.0) GO TO 999
ITIME=RMIN(1)
PIIM(1)=FIME(ITIME)
ITIME=RMIN(2)
PIIM(2)=FIME(ITIME)
ITIME=RMIN(3)
PIIM(3)=FIME(ITIME)
DO 100 I=1,3
IMN(I)=0.0
IMX(I)=0.0
CONTINUE
MENU=4
CALL INCOM(' ENTER FIRST ORBIT POSITION: I(HHMMSS), X, Y, Z (KM)',
* 52,1,1,RMIN,MENU,3,1)
IF(MENU.LE.0) GO TO 999
ITIME=RMIN(1)
I1=FIME(ITIME)
R1(1)=RMIN(2)
R1(2)=RMIN(3)

```

100

A6INT/AOIPS

```

R1(3)=RMIN(4)
MENU=4
CALL INCOM(' ENTER SECOND ORBIT POSITION: T(HHMMSS), X, Y, Z (KM)'
*,53,1,1,RMIN,MENU,3,1)
IF(MENU.GE.0) GO TO 999
ITIME=RMIN(1)
T2=FTIME(ITIME)
R2(1)=RMIN(2)
R2(2)=RMIN(3)
R2(3)=RMIN(4)
CALL GASORB(R1,T1,R2,T2)
999 CONTINUE
IF(JPRI.LE.0) GO TO 1000
WRITE(LP,761)NAVN,INAV,I1R,IDAY
761 FORMAT(1H1,'NAVN=',I5,T27,'INAV=',I10,T52,'YEAR=',I2,T77,'DAY=',I3
*)
WRITE(LP,762) TOTLIN,DEGLIN,TOTIEL,DEGELE
762 FORMAT(T2,'TOTLIN=',F10.2,T27,'DEGLIN=',F10.2,T52,'TOTIEL=',F10.2,
*T77,'DEGELE=',F10.2)
WRITE(LP,763)PICLIN,PICELE,IMPSC
763 FORMAT(I2,'PICLIN=',F10.2,T27,'PICELE=',F10.2,T52,'IMPSC=',F10.2)
WRITE(LP,764)IDYR,IODAY
764 FORMAT(I2,'ORBIT YEAR=',I4,T27,'ORBIT DAY=',I4)
WRITE(LP,765)IM
765 FORMAT(I2,'ORBIT TIME, TM=',F15.4)
WRITE(LP,766)R1X,R1Y,R1Z
766 FORMAT(I2,'POSITION (KM)',I27,'R1X=',F15.3,T52,'R1Y=',F15.4,T77,'R
*1Z=',F15.4)
WRITE(LP,767)R1DX,R1DY,R1DZ
767 FORMAT(I2,'VELOCITY',I27,'R1DX=',E15.9,T52,'R1DY=',E15.9,T77,'R1DZ
*=',E15.9)
PD=PIFCH/RADDEG
RD=ROLL/RADDEG
YD=YAN/RADDEG
WRITE(LP,768)PD,RD,YD
768 FORMAT(I2,'ATTITUDE (DEG)',T27,'PIFCH=',E15.9,T52,'ROLL=',E15.9,T7
*7,'YAN=',E15.9)
WRITE(LP,769)PTIM
769 FORMAT(I2,'PICTURE TIMES',I27,3F25.4)
770 FORMAT(1X,5I25)
771 FORMAT(1X,5E25.9)
WRITE(LP,770)NLCOEF,WRKCOEF,NASCEF
WRITE(LP,771)TMN,TMX
WRITE(LP,770)NRCOEF,NRCOEF
WRITE(LP,771)SCLL0,SCLL1
WRITE(LP,771)ELCOEF
WRITE(LP,771)SCLR0,SCLR1
WRITE(LP,771)ERCOEF
WRITE(LP,770)NASCEF,IELEMN,IELEMX
WRITE(LP,771)SCLAS0,SCLAS1
WRITE(LP,771)ASCOEF
1000 CONTINUE
CALL REQUES(RADS0('AFSF2'))
END

```

ORIGINAL PAGE IS
OF POOR QUALITY

C-2

***** BCTOPF/MCIDAS *****

@ELT,L AF.BCTOPF/MCIDAS

ELT007 RLIB62 12/22-17:01:42-(0,)

```
000001      000      SUBROUTINE BCTOPF(X,Y,Z,DIR)
000002      000      DIMENSION A(3,3)
000003      000      COMMON/NAVCOM/NAVN,INAV,IYR,IDAY,TOTLIN,DEGLIN,TOTIEL,DEGELE,PICLI
000004      000      *N,PICELE,TMPSC,IOYR,IODAY,TM,R1X,R1Y,R1Z,R1DX,R1DY,R1DZ,PITCH,ROL
000005      000      *L,YAW,PTIM(3),TMN(3),TMX(3),NLCOEF(2),NRCOEF(2),SCLLO(2),SCLL1(2),
000006      000      *ELCOEF(11,2),SCLRO(2),SCLR1(2),ERCOEF(11,2),NASCEF,SCLAS0,SCLAS1,
000007      000      *IELEMN,IELEMX,ASCOEF(16)
000008      000      C      PT(3) = YAW, PT(2) = ROLL, PT(1) = PITCH
000009      000      CALL UNIT(A)
000010      000      CALL ROTATE(A,YAW,3,1)
000011      000      CALL ROTATE(A,ROLL,1,1)
000012      000      CALL ROTATE(A,PITCH,2,1)
000013      000      IF(DIR.EQ.2)GO TO 10
000014      000      XT = X*A(1,1)+Y*A(1,2)+Z*A(1,3)
000015      000      YT = X*A(2,1)+Y*A(2,2)+Z*A(2,3)
000016      000      ZT = X*A(3,1)+Y*A(3,2)+Z*A(3,3)
000017      000      X=XT
000018      000      Y=YT
000019      000      Z=ZT
000020      000      RETURN
000021      000      10      XT=X*A(1,1)+Y*A(2,1)+Z*A(3,1)
000022      000      YT = X*A(1,2)+Y*A(2,2)+Z*A(3,2)
000023      000      Z = X*A(1,3)+Y*A(2,3)+Z*A(3,3)
000024      000      X=XT
000025      000      Y=YT
000026      000      RETURN
000027      000      ENDS
```

END ELT.

@HDG,P ***** CNPS/IBHSSP *****

***** BCTOPF/MCIDAS *****

@ELT,L AF.BCTOPF/MCIDAS

ELT007 RLIB62 12/22-17:01:42-(0,)

```
000001 000          SUBROUTINE BCTOPF(X,Y,Z,IDIR)
000002 000          DIMENSION A(3,3)
000003 000          COMMON/NAVCOM/NAVN,INAV,IYR,IDAY,TOTLIN,DEGLIN,TOTIEL,DEGELE,PICLI
000004 000          *N,PICELE,TMPSC,IOYR,IODAY,TM,R1X,R1Y,R1Z,R1DX,R1DY,R1DZ,PITCH,ROL
000005 000          *L,YAW,PTIM(3),TM(3),TMX(3),NLCOEF(2),NRCOEF(2),SCLLO(2),SCLL1(2),
000006 000          *ELCOEF(11,2),SCLRO(2),SCLR1(2),ERCOEF(11,2),NASCEF,SCLAS0,SCLAS1,
000007 000          *IELEMN,IELEMX,ASCOEF(16)
000008 000  C      PT(3) = YAW, PT(2) = ROLL, PT(1) = PITCH
000009 000          CALL UNIT(A)
000010 000          CALL ROTATE(A,YAW,3,1)
000011 000          CALL ROTATE(A,ROLL,1,1)
000012 000          CALL ROTATE(A,PITCH,2,1)
000013 000          IF(IDIR.EQ.2)GO TO 10
000014 000          XT = X*A(1,1)+Y*A(1,2)+Z*A(1,3)
000015 000          YT = X*A(2,1)+Y*A(2,2)+Z*A(2,3)
000016 000          ZT = X*A(3,1)+Y*A(3,2)+Z*A(3,3)
000017 000          X=XT
000018 000          Y=YT
000019 000          Z=ZT
000020 000          RETURN
000021 000  10     XT=X*A(1,1)+Y*A(2,1)+Z*A(3,1)
000022 000          YT = X*A(1,2)+Y*A(2,2)+Z*A(3,2)
000023 000          Z = X*A(1,3)+Y*A(2,3)+Z*A(3,3)
000024 000          X=XT
000025 000          Y=YT
000026 000          RETURN
000027 000          ENDS
```

END ELT.

@HDG,P ***** CNPS/IBMSSP *****

ORIGINAL PAGE IS
OF POOR QUALITY

***** UNIT/MCIDAS *****

@ELT,L AF.UNIT/MCIDAS

ELT007 RLIB62 12/22-17:02:09-(0,)

```
000001 000          SUBROUTINE UNIT(A)
000002 000  C      THIS ROUTINE RETURNS IN "A" A 3 X 3 IDENTITY MATRIX.
000003 000  C
000004 000          DIMENSION A(9),B(9)
000005 000          DATA B/1.0,0.0,0.0,
000006 000          *          0.0,1.0,0.0,
000007 000          *          0.0,0.0,1.0/
000008 000          DO 10 I=1,9
000009 000          10 A(I)=B(I)
000010 000          RETURN
000011 000          ENDS
```

END ELT.

@HDG,N

@FIN

***** STTOLV/MCIDAS *****

@ELT,L AF.STTOLV/MCIDAS

ELT007 RLIB62 12/22-17:02:08-(0,)

```
000001      000      SUBROUTINE STTOLV (X,Y,Z,IDIR,TIME)
000002      000      C      IF IDIR=1, POINTING VECTOR (X,Y,Z) IS TRANSFORMED
000003      000      C      FROM SAT INERTIAL TO LOCAL VERTICAL FRAME.
000004      000      C      IF IDIR=2, POINTING VECTOR (X,Y,Z) IS TRANSFORMED FROM
000005      000      C      LOCAL VERTICAL TO SAT INERTIAL FRAME.
000006      000      CALL ORBIT(XS,YS,ZS,TIME)
000007      000      CALL NRMLIZ(XS,YS,ZS,XNORM)
000008      000      X1=X
000009      000      Y1=Y
000010      000      Z1=Z
000011      000      D=SQRT(XS**2+YS**2)
000012      000      IF (IDIR.EQ.2) GO TO 10
000013      000      X=(-YS*X1+XS*Y1)/D
000014      000      Y=(XS*ZS*X1+YS*ZS*Y1-Z1*D**2)/D
000015      000      Z=- (XS*X1+YS*Y1+ZS*Z1)
000016      000      RETURN
000017      000      10  X=-YS*X1/D+XS+ZS*Y1/D-XS*Z1
000018      000      Y=XS*X1/D+YS+ZS*Y1/D-YS*Z1
000019      000      Z=-D*Y1-ZS*Z1
000020      000      RETURN
000021      000      ENDS
```

END ELT.

@HDG,P ***** UNIT/MCIDAS *****

***** SE/MCIDAS *****

SELT,L AF.SE/MCIDAS

ELT007 RLIB62 12/22-17:02:06-(0,)

```
000001 000 SUBROUTINE SE(PTIME,XLIN,XELE,ALAT,ALON)
000002 000 COMMON/NAVCOM/NAVN,INAV,IYR,IDAY,TOTLIN,DEGLIN,TOTIEL,DEGELE,PICLI
000003 000 *N,PICELE,TMPSC,LOYR,IODAY,TH,R1X,R1Y,R1Z,R1DX,R1DY,R1DZ,PITCH,ROL
000004 000 *L,YAW,PTIM(3),TMX(3),TMX(3),NLCOEF(2),NRCOEF(2),SCLLO(2),SCLL1(2),
000005 000 *ELCOEF(11,2),SCLRO(2),SCLR1(2),ERCOEF(11,2),NASCEF,SCLAS0,SCLAS1,
000006 000 *IELEMN,IELEMX,ASCOEF(16)
000007 000 DATA INIT/O/
000008 000 CALL EDGCR(PTIME,XLIN,DELLIN,DELELE)
000009 000 ALIN=XLIN-DELLIN
000010 000 AELE=XELE-DELELE
000011 000 ISCAN=1200-(IFIX(XLIN-1))/2
000012 000 TIME=PTIME+ISCAN*TMPSC
000013 000 IDIR=2
000014 000 CALL PFTOTC(ALIN,AELE,X1,X2,X3,IDIR,INIT)
000015 000 CALL BCTOPF(X1,X2,X3,IDIR)
000016 000 C BC SAME AS LV HERE.
000017 000 CALL STTOLV(X1,X2,X3,IDIR,TIME)
000018 000 CALL ERTOST(X1ER,X2ER,X3ER,X1,X2,X3,IDIR,TIME)
000019 000 CALL ERTOER(ALAT,ALON,X1ER,X2ER,X3ER,IDIR)
000020 000 RETURN
000021 000 END
```

END ELT.

ENDG,P ***** STTOLV/MCIDAS *****

ORIGINAL PAGE IS
OF POOR QUALITY

***** SATEAR/MCIDAS *****

@ELT,L AF.SATEAR/MCIDAS

ELT007 RLIB62 12/22-17:02:05-(0,)

```
000001      000      SUBROUTINE SATEAR(PICTIM,XLIN,XELE,XLAT,XLON,ITYPE,INAV,BETA IN,BET
000002      000          *DOT,ATFRAC)
000003      000          PTIME=PICTIM
000004      000          GO TO (1,2,3,4,5),ITYPE
000005      000      1      CALL SE(PTIME,XLIN,XELE,XLAT,XLON)
000006      000          RETURN
000007      000      2      CALL ES(PTIME,XLAT,XLON,XLIN,XELE)
000008      000          RETURN
000009      000      3      CONTINUE
000010      000          RETURN
000011      000      4      CONTINUE
000012      000          RETURN
000013      000      5      CONTINUE
000014      000          RETURN
000015      000          END
```

END ELT.

@HDG,P ***** SE/MCIDAS *****

ORIGINAL PAGE IS
OF POOR QUALITY

***** S/MCIDAS *****

@ELT,L AF,S/MCIDAS

ELT007 RLIB62 12/22-17:02:04-(0,)

000001 000 FUNCTION S(PT)

000002 000 C

000003 000 C THIS FUNCTION RETURNS AS ITS VALUE THE VALUE OF THE OBJECTIVE

000004 000 C FUNCTION S AT THE POINT "PT".

000005 000 C

000006 000 DIMENSION X(3,150),Y(3,150),TIME(150)

000007 000 COMMON/MINCOM/X,Y,TIME,NP

000008 000 DIMENSION PT(3),H(3,3)

000009 000 SRES=0

000010 000 CALL UNIT(H)

000011 000 CALL ROTATE(H,PT(3),3,1)

000012 000 CALL ROTATE(H,PT(2),1,1)

000013 000 CALL ROTATE(H,PT(1),2,1)

000014 000 DO 10 J=1,NP

000015 000 DO 10 I=1,3

000016 000 10 SRES=SRES+(Y(I,J)-H(I,1)*X(1,J)-H(I,2)*X(2,J)-H(I,3)*X(3,J))**2

000017 000 S=SRES

000018 000 RETURN

000019 000 ENDS

END ELT.

@HDG,P ***** SATEAR/MCIDAS *****

***** ROTATE/MCIDAS *****

```

@ELT,L AF.ROTATE/MCIDAS
ELT007 RLIB62 12/22-17:02:03-(0,)
000001 000 SUBROUTINE ROTATE(A,R,IR,IDERIV)
000002 000 C
000003 000 C THIS ROUTINE RETURNS IN "A" THE PRODUCT OF THE INPUT MATRIX
000004 000 C "A" AND A MATRIX RM, WHERE, IF "IDERIV"=1, RM REPRESENTS A
000005 000 C ROTATION THROUGH AN ANGLE "R" (IN RADIANS) ABOUT THE AXIS "IR". IF
000006 000 C IDERIV=2, THE FIRST DERIVATIVE OF RM IS OPERATED ON A, AND IF
000007 000 C IDERIV=3, THE SECOND DERIVATIVE OF RM IS USED.
000008 000 C
000009 000 DIMENSION A(3,3),INDX1(3),INDX2(3)
000010 000 DATA INDX1,INDX2/2,1,1,3,3,2/
000011 000 IR1=INDX1(IR)
000012 000 IR2=INDX2(IR)
000013 000 CR=DCOS(R)
000014 000 SR=DSIN(R)
000015 000 IF(IDERIV.NE.1)GO TO 2
000016 000 DO 1 J=1,3
000017 000 T1=A(IR1,J)
000018 000 T2=A(IR2,J)
000019 000 A(IK1,J)=CR*T1+SR*T2
000020 000 A(IR2,J)=-SR*T1+CR*T2
000021 000 1 CONTINUE
000022 000 RETURN
000023 000 2 IF(IDERIV.NE.2)GO TO 4
000024 000 DO 3 J=1,3
000025 000 A(IR,J)=0.0
000026 000 T1=A(IR1,J)
000027 000 T2=A(IR2,J)
000028 000 A(IR1,J)=-SR*T1+CR*T2
000029 000 A(IR2,J)=-CR*T1-SR*T2
000030 000 3 CONTINUE
000031 000 RETURN
000032 000 4 CONTINUE
000033 000 DO 5 J=1,3
000034 000 A(IR,J)=0.0
000035 000 T1=A(IR1,J)
000036 000 T2=A(IR2,J)
000037 000 A(IR1,J)=-CR*T1-SR*T2
000038 000 A(IR2,J)=SR*T1-CR*T2
000039 000 5 CONTINUE
000040 000 RETURN
000041 000 ENDS
```

END ELT.

@HDG,P ***** S/MCIDAS *****

ORIGINAL PAGE IS
OF POOR QUALITY

***** PRTIAL/MCIDAS *****

```
000056      000      CALL ROTATE(HBC,B,1,2)
000057      000      CALL ROTATE(HBC,A,2,1)
000058      000      CALL UNIT(HCC)
000059      000      CALL ROTATE(HCC,C,3,3)
000060      000      CALL ROTATE(HCC,B,1,1)
000061      000      CALL ROTATE(HCC,A,2,1)
000062      000      DO10J=1,NP
000063      000      DO10I=1,3
000064      000      T=Y(I,J)-H(I,1)*X(1,J)-H(I,2)*X(2,J)-H(I,3)*X(3,J)
000065      000      TA=HA(I,1)*X(1,J)+HA(I,2)*X(2,J)+HA(I,3)*X(3,J)
000066      000      TB=HB(I,1)*X(1,J)+HB(I,2)*X(2,J)+HB(I,3)*X(3,J)
000067      000      TC=HC(I,1)*X(1,J)+HC(I,2)*X(2,J)+HC(I,3)*X(3,J)
000068      000      TAA=HAA(I,1)*X(1,J)+HAA(I,2)*X(2,J)+HAA(I,3)*X(3,J)
000069      000      TAB=HAB(I,1)*X(1,J)+HAB(I,2)*X(2,J)+HAB(I,3)*X(3,J)
000070      000      TAC=HAC(I,1)*X(1,J)+HAC(I,2)*X(2,J)+HAC(I,3)*X(3,J)
000071      000      TBB=HBB(I,1)*X(1,J)+HBB(I,2)*X(2,J)+HBB(I,3)*X(3,J)
000072      000      TBC=HBC(I,1)*X(1,J)+HBC(I,2)*X(2,J)+HBC(I,3)*X(3,J)
000073      000      TCC=HCC(I,1)*X(1,J)+HCC(I,2)*X(2,J)+HCC(I,3)*X(3,J)
000074      000      PSPA=PSPA-T*TA
000075      000      PSPB=PSPB-T*TB
000076      000      PSPC=PSPC-T*TC
000077      000      PSPASQ=PSPASQ-T*TAA+TA**2
000078      000      PSPAPB=PSPAPB-T*TAB+TA*TB
000079      000      PSPAPC=PSPAPC-T*TAC+TA*TC
000080      000      PSPBSQ=PSPBSQ-T*TBB+TB**2
000081      000      PSPBPC=PSPBPC-T*TBC+TB*TC
000082      000      10 PSPCSQ=PSPCSQ-T*TCC+TC**2
000083      000      GRAD(1)=2*PSPA
000084      000      GRAD(2)=2*PSPB
000085      000      GRAD(3)=2*PSPC
000086      000      HESS(1,1)=2*PSPASQ
000087      000      HESS(1,2)=2*PSPAPB
000088      000      HESS(2,1)=2*PSPAPB
000089      000      HESS(1,3)=2*PSPAPC
000090      000      HESS(3,1)=2*PSPAPC
000091      000      HESS(2,2)=2*PSPBSQ
000092      000      HESS(2,3)=2*PSPBPC
000093      000      HESS(3,2)=2*PSPBPC
000094      000      HESS(3,3)=2*PSPCSQ
000095      000      RETURN
000096      000      ENDS
```

END ELT.

QHOG,P ***** ROTATE/MCIDAS *****

***** PRTIAL/MCIDAS *****

```
@ELT,L AF.PRTIAL/MCIDAS
ELT007 RLIB62 12/22-17:02:03-(0,)
000001 000 SUBROUTINE PRTIAL(PT,GRAD,HESS)
000002 000 C
000003 000 C THIS ROUTINE RETURNS IN "GRAD" THE GRADIENT OF S AT "PT" AND IN
000004 000 C "HESS" THE HESSIAN OF S AT "PT".
000005 000 C
000006 000 DIMENSION X(3,150),Y(3,150),TIME(150)
000007 000 COMMON/MINCOM/X,Y,TIME,NP
000008 000 DIMENSIONPT(3),GRAD(3),HESS(3,3),H(3,3),HA(3,3),HB(3,3),HC(3,3),
000009 000 *HAA(3,3),HAB(3,3),HAC(3,3),HBB(3,3),HBC(3,3),HCC(3,3)
000010 000 A=PT(1)
000011 000 B=PT(2)
000012 000 C=PT(3)
000013 000 PSPA=0
000014 000 PSPB=0
000015 000 PSPC=0
000016 000 PSPASQ=0
000017 000 PSPAPB=0
000018 000 PSPAPC=0
000019 000 PSPBSQ=0
000020 000 PSPBPC=0
000021 000 PSPCSQ=0
000022 000 CALL UNIT(H)
000023 000 CALL ROTATE(H,C,3,1)
000024 000 CALL ROTATE(H,B,1,1)
000025 000 CALL ROTATE(H,A,2,1)
000026 000 CALL UNIT(HA)
000027 000 CALL ROTATE(HA,C,3,1)
000028 000 CALL ROTATE(HA,B,1,1)
000029 000 CALL ROTATE(HA,A,2,2)
000030 000 CALL UNIT(HB)
000031 000 CALL ROTATE(HB,C,3,1)
000032 000 CALL ROTATE(HB,B,1,2)
000033 000 CALL ROTATE(HB,A,2,1)
000034 000 CALL UNIT(HC)
000035 000 CALL ROTATE(HC,C,3,2)
000036 000 CALL ROTATE(HC,B,1,1)
000037 000 CALL ROTATE(HC,A,2,1)
000038 000 CALL UNIT(HAA)
000039 000 CALL ROTATE(HAA,C,3,1)
000040 000 CALL ROTATE(HAA,B,1,1)
000041 000 CALL ROTATE(HAA,A,2,3)
000042 000 CALL UNIT(HAB)
000043 000 CALL ROTATE(HAB,C,3,1)
000044 000 CALL ROTATE(HAB,B,1,2)
000045 000 CALL ROTATE(HAB,A,2,2)
000046 000 CALL UNIT(HAC)
000047 000 CALL ROTATE(HAC,C,3,2)
000048 000 CALL ROTATE(HAC,B,1,1)
000049 000 CALL ROTATE(HAC,A,2,2)
000050 000 CALL UNIT(HBB)
000051 000 CALL ROTATE(HBB,C,3,1)
000052 000 CALL ROTATE(HBB,B,1,3)
000053 000 CALL ROTATE(HBB,A,2,1)
000054 000 CALL UNIT(HBC)
000055 000 CALL ROTATE(HBC,C,3,2)
```

ORIGINAL PAGE IS
OF POOR QUALITY

***** PFTOTC/MCIDAS *****

```
@ELT,L AF,PFTOTC/MCIDAS
ELT007 RLIB62 12/22-17:02:02-(0,)
000001 000 SUBROUTINE PFTOTC(XLIN,XELE,X,Y,Z,DIR,INIT)
000002 000 COMMON/NAVCOM/NAVN,INAV,IYR,IDAY,TOTLIN,DEGLIN,TOTIEL,DEGELE,PICLI
000003 000 *N,PICELE,TPMSCL,IOYP,IODAY,TM,R1X,R1Y,R1Z,R1DX,R1DY,R1DZ,PITCH,ROL
000004 000 *L,YAW,PTIM(3),TMN(3),TMX(3),NLCOEF(2),NRCOEF(2),SCLLO(2),SCLL1(2),
000005 000 *ELCOEF(11,2),SCLRO(2),SCLR1(2),ERCOEF(11,2),NASCEF,SCLAS0,SCLAS1,
000006 000 *IELEMN,IELEMX,ASCOEF(16)
000007 000 C IF DIR = 1, X,Y,Z TO LIN, ELE
000008 000 C IF DIR = 2, LIN, ELE TO X,Y,Z
000009 000 DATA PI,RE,GRACON/3.14159265,6378.15,.07436574/
000010 000 IF(INIT.EQ.2)GO TO 1
000011 000 INIT = 2
000012 000 RDPDG = PI/180.
000013 000 RADLIN = RDPDG*DEGLIN/TOTLIN
000014 000 RADELE = RDPDG*DEGELE/TOTIEL
000015 000 1 IF(DIR.EQ.2)GO TO 10
000016 000 ELEANG = ATAN(X/Z)
000017 000 XLNANG = ASIN(Y)
000018 000 XELE=PICELE+ELEANG/RADELE
000019 000 XLIN = PICLIN+XLNANG/RADLIN
000020 000 RETURN
000021 000 10 ELEANG=(PICELE-XELE)*RADELE
000022 000 XLNANG = (PICLIN-XLIN)*RADLIN
000023 000 X=-COS(XLNANG)*SIN(ELEANG)
000024 000 Y=-SIN(XLNANG)
000025 000 Z=COS(XLNANG)*COS(ELEANG)
000026 000 RETURN
000027 000 ENDS
```

END ELT.

@HDG,P ***** PRTIAL/MCIDAS *****

***** ORBIT/MCIDAS *****

@ELT,L AF. ORBIT/MCIDAS

ELT007 RLIB62 12/22-17:02:01-(0,)

```
000001 000 SUBROUTINE ORBIT(X,Y,Z,T)
000002 000 REAL KE,MU,MMINMO
000003 000 COMMON/NAVCOM/NAVN,INAV,IYR,JDAY,TOTLIN,DEGLIN,TOTIEL,DEGELE,PICLI
000004 000 *N,PICELE,TMPSC,L,IYR,IODAY,TH,R1X,R1Y,R1Z,R1DX,R1DY,R1DZ,PITCH,ROL
000005 000 *L,YAW,PTIM(3),TMN(3),TMX(3),MLCOEF(2),NRCOE(2),SCLLO(2),SCLL1(2),
000006 000 *ELCOEF(11,2),SCLRO(2),SCLR1(2),ERCOEF(11,2),NASCEF,SCLAS0,SCLAS1,
000007 000 *IELEMN,IELEMX,ASCOEF(16)
000008 000 DATA RE,KE,MU,EPSILN/6378.15,0.07436574,1.0,1.0E-7/
000009 000 SQRTMU=SQRT(MU)
000010 000 RO=SQRT(R1X**2+R1Y**2+R1Z**2)
000011 000 DO=(R1X*R1DX+R1Y*R1DY+R1Z*R1DZ)/SQRTMU
000012 000 VOSQMU=(R1DX**2+R1DY**2+R1DZ**2)/SQRTMU
000013 000 A=RO/(2.-RO*VOSQMU)
000014 000 CE=(A-RO)/A
000015 000 SE=DO/SQRT(A)
000016 000 MMINMO=KE*(T-TM)*SQRTMU/A**1.5
000017 000 GL=.5*MMINMO
000018 000 5 SINGL=SIN(GL)
000019 000 SNCSGL=SINGL*COS(GL)
000020 000 XNUM=GL+SE*SINGL**2-CE*SNCSGL-.5*MMINMO
000021 000 DENOM=1+2*SE*SNCSGL-CE*(1-2*SINGL**2)
000022 000 G=(GL*DENOM-XNUM)/DENOM
000023 000 IF(ABS(GL-G).LT.EPSILN)GOTO10
000024 000 GL=G
000025 000 GOTO 5
000026 000 10 ECANOM=2*G
000027 000 C=A*(1-COS(ECANOM))
000028 000 S=SQRT(A)*SIN(ECANOM)
000029 000 F=(RO-C)/RO
000030 000 G=1/SQRTMU*(RO*S+DO*C)
000031 000 X=(F*R1X+G*R1DX)*RE
000032 000 Y=(F*R1Y+G*R1DY)*RE
000033 000 Z=(F*R1Z+G*R1DZ)*RE
000034 000 RETURN
000035 000 ENDS
```

END ELT.

@HDG,P ***** PACK *****

ORIGINAL PAGE IS
OF POOR QUALITY

***** OFSTG/MCIDAS *****

```
000113      000  C      DUMP TABLE VALUES.
000114      000      NICOL=(NCOR-1)/5+1
000115      000      JOUT=2
000116      000      DO 650 IWW=1,NICOL
000117      000      ENCODE(132,710,MOUT)(ICOR(IW),OFFSET(IW),WATE(IW),IW=IWW,NCOR,
000118      000      *NICOL)
000119      000      CALL TP(JOUT,MOUT)
000120      000  650      CONTINUE
000121      000  710      FORMAT ((5(5X,I4,1X,F8.3,F8.4)))
000122      000      NCORMX=NCOR
000123      000      CALL DYNASG('OFFSTD',LUNF)
000124      000      CALL OPN(LUNF)
000125      000      CALL WRITW(LUNF,1151,NCORMX)
000126      000      RETURN
000127      000  990      CONTINUE
000128      000      CALL TQ(72H OFFSETGEN ERROR RETURN.
000129      000      *
000130      000      RETURN
000131      000      ENDS
000132      000  $FILEMA
000133      000  DELETE GCCGCC,GORP
000134      000  $INCLUDE IFLD
000135      000  $CATALOG
000136      000  NAME=GCCGCC,5,R,W,D
000137      000  TYPE=FG
000138      000  LIB=ATSFLL,LL
000139      000  BEGIN
000140      000  $EOJ
```

END ELT.

@HDG,P ***** OFSTVL *****

***** DFSTG/MCIDAS *****

```
000056      000      CALL BSR(LUN)
000057      000      CALL BSR(LUN)
000058      000      C      INPUT PAIR OF SCANS.
000059      000      CALL READW(LUN,NW2,IEDATA)
000060      000      CALL READW(LUN,NW2,IODATA)
000061      000      CALL CRKTHR(195,IEDATA,IEBRT)
000062      000      JESCAN=IEBRT(195)
000063      000      CALL CRKATS(NBP,IEDATA,IEBRT)
000064      000      CALL CRKTHR(195,IODATA,IOBRT)
000065      000      JOSCAN=IOBRT(195)
000066      000      CALL CRKATS(NBP,IODATA,IOBRT)
000067      000      IF(JESCAN.NE.IESCAN.OR.JOSCAN.NE.IOSCAN) GO TO 990
000068      000      C
000069      000      C      DO CORRELATIONS.
000070      000      C
000071      000      DO 600 KCOR=1,NCOR
000072      000      IELE=IELEST+(KCOR-1)*IELINT
000073      000      ICOOR(KCOR)=IELE
000074      000      MAXLAG=(NLAG-1)/2
000075      000      MINLAG=-MAXLAG
000076      000      DO 500 KLAG=MINLAG,MAXLAG
000077      000      MAXBRT=0
000078      000      MINBRT=512
000079      000      NTSIZ=(NTSIZ-1)/2*2+1
000080      000      FLP=0
000081      000      DO 400 KVAL=1,NTSIZ
000082      000      ICT=IELE+KVAL-1-NTSIZ/2
000083      000      ICS=IELE+KVAL-1+KLAG+NOMOFF-NTSIZ/2
000084      000      ICTX=ICT+IDOFF
000085      000      ICSX=ICS+IDOFF
000086      000      IPIXT=IOBRT(ICTX)
000087      000      IPIXS=IEBRT(ICSX)
000088      000      MAXBRT=MAXQ(MAXBRT,IPIXT)
000089      000      MINBRT=MINQ(MINBRT,IPIXS)
000090      000      FLP=FLP+(IPIXT-IPIXS)**2
000091      000      400      CONTINUE
000092      000      C      STORE LP(2) MEASURE VALUE
000093      000      FLPARY(KLAG-MINLAG+1)=FLP
000094      000      500      CONTINUE
000095      000      C      SEARCH TABLE OF VALUES OF LP(2) MEASURE FOR MIN.
000096      000      IOFF=NOMOFF+MINLAG
000097      000      FLPMIN=FLPARY(1)
000098      000      DO 510 K=2,NLAG
000099      000      IF(FLPMIN.GT.FLPARY(K)) IOFF=NOMOFF+(K-1)+MINLAG
000100      000      IF(FLPMIN.GT.FLPARY(K)) FLPMIN=FLPARY(K)
000101      000      510      CONTINUE
000102      000      C      WEIGHT OFFSETS BY BRIGHTNESS RANGE.
000103      000      WT=FLOAT(MAXBRT-MINBRT)/512.
000104      000      WATE(KCOR)=WATE(KCOR)+WT
000105      000      OFFSET(KCOR)=OFFSET(KCOR)+IOFF*WT
000106      000      600      CONTINUE
000107      000      IF(.NOT.ISLAST) GO TO 100
000108      000      C      COMPUTE AVERAGE OFFSETS.
000109      000      DO 610 KCOR=1,NCOR
000110      000      IF(WATE(KCOR).LT.1.0E-3) GO TO 610
000111      000      OFFSET(KCOR)=OFFSET(KCOR)/WATE(KCOR)
000112      000      610      CONTINUE
```

***** OFSTG/MCIDAS *****

```
DELTA, L AF.OFSTG/MCIDAS
ELT007 RLIB62 12/22-17:01:59-(0,)
000001 000 $JOB ATS6 U3200
000002 000 $OPTION.8,9,20
000003 000 $FORTRAN
000004 000 SUBROUTINE MAIN
000005 000 C OF ALTERNATE SCAN OFFSETS. CORRELATIONS DONE ON IR.
000006 000 C ASSIGN TAPE TO UNIT 10. OUTPUT IS TO PRINTER AND UNIT 20.
000007 000 LOGICAL MISSNG,ISLAST
000008 000 DIMENSION IODATA(1299),IEDATA(1299)
000009 000 DIMENSION MIN(10),MOUT(24)
000010 000 DIMENSION IOBRT(2598),IEBRT(2598)
000011 000 DIMENSION WATE(230),OFFSET(230),ICOR(230),FLPARY(9)
000012 000 COMMON/OFFDAT/NCORMX,ICOR,OFFSET,WATE
000013 000 DATA ISTATG/0/,NLAG/9/,NCOR/220/,LPRT/6/
000014 000 DATA MIN/6HGCGGCC,8*0/
000015 000 DATA NW1/98/,NW2/1299/,NW3/3732/
000016 000 DATA LUN/10/,MISSNG/.FALSE./
000017 000 DATA LUNF/20/
000018 000 DATA IFIRST/600/,INTSCN/ 8/,LSTSCN/400/
000019 000 DATA IELEST/100/,NTSIZ/15/,NOMOFF/ +8/,IELINT/10/
000020 000 DATA NBP/2598/,IDOFF/198/
000021 000 DATA IDSTRT/67/
000022 000 CALL IQ(MIN)
000023 000 IREEL=0
000024 000 C INITIALIZE SCAN SEARCH
000025 000 IFIRST=((IFIRST+1)/2)*2
000026 000 INTSCN=(INTSCN/2)*2
000027 000 LSTSCN=((LSTSCN+1)/2)*2
000028 000 IESCAN=IFIRST+INTSCN
000029 000 CALL GTAP(14,IREEL,LUN)
000030 000 CALL REW(LUN)
000031 000 C SKIP HEADER RECORDS
000032 000 CALL READW(LUN,NW1,IEDATA)
000033 000 CALL READW(LUN,NW1,IEDATA)
000034 000 100 IF(MISSNG) IESCAN=IESCAN-2
000035 000 IF(.NOT.MISSNG) IESCAN=IESCAN-INTSCN
000036 000 IOSCAN=IESCAN-1
000037 000 ISLAST=IESCAN.LE.LSTSCN
000038 000 200 CALL READW(LUN,NW1,IEDATA)
000039 000 CALL CRKTHR(195,IEDATA,IEBRT)
000040 000 JESCAN=IEBRT(195)
000041 000 MISSNG=JESCAN.LT.IESCAN
000042 000 IF(MISSNG) ENCODE(132,701,MOUT)IESCAN
000043 000 IF(MISSNG) CALL TQ(MOUT)
000044 000 701 FORMAT(1X,'SCAN NUMBER',I5,' NOT FOUND.')
000045 000 IF(MISSNG) GO TO 100
000046 000 IF(JESCAN.GT.IESCAN) GO TO 200
000047 000 C EVEN SCAN FOUND. NOW CHECK FOR ODD SCAN.
000048 000 CALL READW(LUN,NW1,IODATA)
000049 000 CALL CRKTHR(195,IODATA,IOBRT)
000050 000 JOSCAN=IOBRT(195)
000051 000 MISSNG=JOSCAN.NE.IOSCAN
000052 000 IF(MISSNG) ENCODE(132,701,MOUT) IOSCAN
000053 000 IF(MISSNG) CALL TQ(MOUT)
000054 000 IF(MISSNG) GO TO 100
000055 000 C BACK UP TO READ IN DATA.
```

ORIGINAL PAGE IS
OF POOR QUALITY

OFSTG/AOIPS

```
JOUF=2
DD 650 Iww=1,NICOL
WRITE(LP,710)(ICUOR(IW),OFFSET(IW),WATE(IW),IW=Iww,NCOR,NICOL)
650 CONTINUE
710 FORMAT ((5(5X,14,1X,F8.3,F8.4)))
NCDKMX=NCOR
GO TO 999
990 CONTINUE
WRITE(S,715)
715 FORMAT(2X,'OFFSETIGEN ERROR RETURN.')
```

999 CONTINUE
CALL IOPRW(LUN)
CALL REQUES(RAD50('OFSTF2'))
END

OFSTG/AOIPS

```

C   EVEN SCAN FOUND. NOW CHECK FOR ODD SCAN.
    CALL IOTPIN(LUN, IODATA, NW1, LE, ISTAT)
    CALL CRKTHR(195, IODATA, IOBRT)
    JOSCAN=IOBRT(195)
    MISSNG=JOSCAN.NE.IOSCAN
    IF(MISSNG)WRITE(IT,701)IOSCAN
    IF(MISSNG) GO TO 100
C   BACK UP TO READ IN DATA.
    CALL IOTPSR(LUN,-2, ISTAT)
C   INPUT PAIR OF SCANS.
    CALL IOTPIN(LUN, IEDATA, NW2, LE, ISTAT)
    CALL CRKTHR(195, IEDATA, IOBRT)
    JESCAN=IOBRT(195)
    CALL CRKAIS(NBP, IEDATA, IOBRT)
    CALL IOTPIN(LUN, IODATA, NW2, LE, ISTAT)
    CALL CRKTHR(195, IODATA, IOBRT)
    JOSCAN=IOBRT(195)
    CALL CRKAIS(NBP, IODATA, IOBRT)
    IF(JESCAN.NE.IESCAN.OR.JOSCAN.NE.IOSCAN) GO TO 990
C
C   DO CORRELATIONS.
C
    DO 600 KCOR=1, NCOR
    IELE=IELEST+(KCOR-1)*IELINT
    ICORR(KCOR)=IELE
    MAXLAG=(NLAG-1)/2
    MINLAG=-MAXLAG
    DO 500 KLAG=MINLAG, MAXLAG
    MAXBRT=0
    MINBRT=512
    NTSIZ=(NTSIZ-1)/2*2+1
    FLP=0
    DO 400 KVAL=1, NTSIZ
    ICT=IELE+KVAL-1-NTSIZ/2
    ICS=IELE+KVAL-1+KLAG+NOMOFF-NTSIZ/2
    ICTX=ICT+IOFF
    ICSX=ICS+IOFF
    IPIXT=IOBRT(ICTX)
    IPIXS=IOBRT(ICSX)
    MAXBRT=MAX0(MAXBRT, IPIXT)
    MINBRT=MIN0(MINBRT, IPIXS)
    FLP=FLP+(IPIXT-IPIXS)*#2
400  CONTINUE
C   STORE LP(2) MEASURE VALUE
    FLPARY(KLAG-MINLAG+1)=FLP
500  CONTINUE
C   SEARCH TABLE OF VALUES OF LP(2) MEASURE FOR MIN.
    IOFF=NOMOFF+MINLAG
    FLPMIN=FLPARY(1)
    DO 510 K=2, NLAG
    IF(FLPMIN.GT.FLPARY(K)) IOFF=NOMOFF+(K-1)+MINLAG
    IF(FLPMIN.GT.FLPARY(K)) FLPMIN=FLPARY(K)
510  CONTINUE
C   WEIGHT OFFSETS BY BRIGHTNESS RANGE.
    WT=FLDAI(MAXBRT-MINBRT)/512.
    WATE(KCOR)=AAIE(KCOR)*WT
    OFFSET(KCOR)=OFFSET(KCOR)+IOFF*WT
600  CONTINUE
    IF(.NOT.I$LAST) GO TO 100
    COMPUTE AVERAGE OFFSETS.
    DO 610 KCOR=1, NCOR
    IF(WATE(KCOR).LT.1.0E-3) GO TO 610
    OFFSET(KCOR)=OFFSET(KCOR)/WATE(KCOR)
610  CONTINUE
C   DUMP TABLE VALUES.
    NICOL=(NCOR-1)/5+1

```

ORIGINAL PAGE IS
OF POOR QUALITY

OFSTG/AOIPS

```

C PROGRAM TO GENERATE TABLE
C OF ALTERNATE SCAN OFFSETS. CORRELATIONS DONE ON IR.
C ASSIGN TAPE ID UNIL TEN. OUTPUT IS TO PRINTER AND GLOBAL COMMON
LOGICAL MISSING,ISLAST
DIMENSION IODATA(5600),IEDATA(5600)
EQUIVALENCE(IODATA,IEDATA)
DIMENSION MIN(10),MOUI(37)
DIMENSION IORRT(2598),IEBRT(2598)
DIMENSION WAIE(230),OFFSET(230),ICOR(230),FLPARY(9)
COMMON/BUFFER/WAIE,OFFSET
COMMON/BUFF1/NCORMX,ICOR
DATA ISTAT/0/,NLAG/9/,NCOR/220/,LPRT/6/
DATA NW1/147/,NW2/1949/,NW3/5598/
DATA LUN/10/,MISSNG/,FALSE./
DATA LP/6/,LI/5/
DATA IFIRST/800/,INISCN/ 8/,LSTSCN/400/
DATA IELEST/100/,NTSIZ/15/,NOMOFF/ +8/,IELINT/10/
DATA NBP/2598/,IOFF/198/
DATA IDSTRT/67/
C INITIALIZE SCAN SEARCH
IFIRST=((IFIRST+1)/2)*2
INISCN=(INISCN/2)*2
LSTSCN=((LSTSCN+1)/2)*2
IESCAN=IFIRST+INISCN
NCORMX=0
DO 10 I=1,230
WAIE(I)=0.
OFFSET(I)=0.0
ICOR(I)=0
10 CONTINUE
ENCODE(74,702,MOUI)
702 FORMAT(1X,'MOUNT TAPE. ENTER DRIVE NUMBER')
MENU=1
CALL INCOM(MOUT,36,1,1,MIN,MENU,1,1)
IMUNIT=MIN(1)
IF(MENU.LT.0) GO TO 999
IF(MENU.EQ.0)IMUNIT=0
CALL ASNDUN(LUN,'MM',IMUNIT)
CALL IUTPRW(LUN)
C SKIP HEADER RECORDS
CALL IUTPSR(LUN,+2,ISTAT)
100 IF(MISSNG) IESCAN=IESCAN-2
IF(.NOT.MISSNG) IESCAN=IESCAN-INTSCN
IOSCAN=IESCAN-1
ISLAST=IESCAN.LE.LSTSCN
200 CALL IOFPIN(LUN,IEDATA,NW1,LE,ISTAT)
CALL CKIHR(195,IEDATA,IEBRT)
JESCAN=IEBRT(195)
MISSNG=JESCAN.LI.IESCAN
IF(MISSNG)WRITE(11,701)IESCAN
701 FORMAT(1X,'SCAN NUMBER',15,' NOT FOUND.')
IF(MISSNG) GO TO 100
IF(JESCAN.GT.IESCAN) GO TO 200

```

***** OFSTF/MCIDAS *****

```
000056      000      SCLAS0=XD
000057      000      SCLAS1=XD
000058      000      IELEMN=ILE
000059      000      IELEMX=IRE
000060      000      IX=M*(M-1)/2
000061      000      DO 29 I=0,M
000062      000      COEF(I+1)=WORK(I+1+IX)
000063      000  29    ASCOEF(I+1)=COEF(I+1)
000064      000  C    STORE DATA
000065      000      CALL WCOM
000066      000  C    PRINT COEFFICIENT, DEGREE SCALING
000067      000      ENCODE(132,720,MOUT)M
000068      000      CALL TP(JOUT,MOUT)
000069      000  720  .FORMAT(10X,'DEGREE=',I2)
000070      000      ENCODE(132,721,MOUT)XD,XD
000071      000      CALL TP(JOUT,MOUT)
000072      000  721  FORMAT(2X,'SCALING PARAMETERS. X0=',E15.9,' XD=',E15.9)
000073      000      DO 30 I=0,M
000074      000      ENCODE(132,722,MOUT)I,COEF(I+1)
000075      000  30    CALL TP(JOUT,MOUT)
000076      000  722  FORMAT(10X,'D(',I2,')=',E15.9)
000077      000      RETURN
000078      000  990  CONTINUE
000079      000      ENCODE(132,720,MOUT)IER
000080      000      CALL TQ(MOUT)
000081      000      RETURN
000082      000  730  FORMAT(1X,'ERROR CODE=',I2)
000083      000      ENDS
000084      000      SFILEMA
000085      000      DELETE GCCGCC,GORP
000086      000      INCLUDE ATSSSP
000087      000      SCATALOG
000088      000      NAME=GCCGCC,S,R,W,D
000089      000      TYPE=FG
000090      000      LIB=ATSFLL,LL
000091      000      BEGIN
000092      000      SE0J
```

END ELT.

@HDG,P ***** OFSTG/MCIDAS *****

ORIGINAL PAGE 1
OF POOR QUALITY

***** OFSTF/MCIDAS *****

```
DELTA AF.OFSTF/MCIDAS
ELT007 RLIB62 12/22-17:01:58-(0,)
000001 000 $JOB OFSTFT U3200
000002 000 $OPTION ,8,9,13,20
000003 000 $FORTRAN
000004 000 SUBROUTINE MAIN
000005 000 C PROGRAM TO FIT POLYNOMIAL TO ALTERNATE SCAN OFFSET DATA STORED IN
000006 000 C UNIT 10 BY PROGRAM OFFSETGEN. INPUT DATA:
000007 000 C CARD1: FIRST-POINT-ELEMENT-COORDINATE LAST-POINT
000008 000 LOGICAL OPTION
000009 000 DIMENSION ICORLM(2),XSCALE(10),OFSTLM(2),YSCALE(10)
000010 000 DIMENSION DATI(690),WORK(231)
000011 000 DIMENSION COEF(21),LABEL(12)
000012 000 DIMENSION MIN(10),MOUT(24)
000013 000 COMMON/OFFDAT/NCORMX,ICOOR(230),OFFSET(230),WATE(230)
000014 000 COMMON/NAVCOM/NAVN,INAV,IYR,IDAY,TOTLIN,DEGLIN,TOTIEL,DEGELE,PICLI
000015 000 *N,PICELE,TPMSCL,IOYR,IODAY,TM,R1X,R1Y,R1Z,R1UX,R1DY,R1DZ,PITCH,ROL
000016 000 *L,YAW,PTIM(3),TMN(3),TMX(3),NLCOEF(2),NRCOE(2),SCLLO(2),SCLL1(2),
000017 000 *ELCOEF(11,2),SCLRO(2),SCLR1(2),ERCOEF(11,2),NASCEF,SCLAS0,SCLAS1,
000018 000 *IELEMN,IELEMX,ASCOEF(16)
000019 000 DATA ICORLM/0,2400/,OFSTLM/5.,15./
000020 000 DATA LP/6/
000021 000 DATA MINDEG/15/
000022 000 DATA MIN/6HGCGGCC,8*0/,LUNF/10/
000023 000 CALL IQ(MIN)
000024 000 C READ LIMITS OF USEFUL DATA (ICOOR LIMITS) FROM CARDS.
000025 000 ILE=MIN(1)
000026 000 IRE=MIN(2)
000027 000 JOUT=1
000028 000 IF(OPTION(MIN(3),3H P)) JOUT=2
000029 000 C READ IN OFFSETS AND WEIGHTS AND COORDINATES(ELEMENT NUMBER)
000030 000 CALL DYNASG('OFFSTD',LUNF)
000031 000 CALL OPN(LUNF)
000032 000 CALL READW(LUNF,1151,NCORMX)
000033 000 DO 10 I=1,NCORMX
000034 000 IF(ICOOR(I).EQ.ILE) ILEAE=I
000035 000 IF(ICOOR(I).EQ.IRE) IREAE=I
000036 000 10 CONTINUE
000037 000 NPTS=IREAE-ILEAE+1
000038 000 C FIT LEAST SQUARES POLYNOMIAL.
000039 000 IN=0
000040 000 DO 25 I=ILEAE,IREAE
000041 000 IN=IN+1
000042 000 DATI(IN)=ICOOR(I)
000043 000 DATI(IN+NPTS)=OFFSET(I)
000044 000 DATI(IN+2*NPTS)=WATE(I)
000045 000 25 CONTINUE
000046 000 CALL APCH(DATI,NPTS,MINDEG,XD,X0,WORK,IER)
000047 000 IF(IER.NE.0) GO TO 990
000048 000 ETA=1.0E-3
000049 000 EPS=1.0E-4
000050 000 IOP=-1
000051 000 CALL APFS(WORK,MINDEG,M,IOP,EPS,ETA,IER)
000052 000 IF(IER)990,28,28
000053 000 28 CONTINUE
000054 000 CALL RCOM
000055 000 NASCEF=M
```

OFSTF/AOIPS

```
IELENX=IRE
IX=M*(M-1)/2
DO 29 I=0,M
COEF(I+1)=WORK(1+1+IX)
29 ASCOEF(1+1)=COEF(I+1)
C PRINT COEFFICIENT, DEGREE SCALING
WRITE(1F,720)M
720 FORMAT(10X,'DEGREE=',I2)
WRITE(11,721)X0,XD
721 FORMAT(2X,'SCALING PARAMETERS. X0=',E15.9,' XD=',E15.9)
DO 30 I=0,M
30 WRITE(1F,722)I,COEF(I+1)
722 FORMAT(10X,'D(',I2,')=',E15.9)
GO TO 999
990 CONTINUE
WRITE(1F,730)IER
999 CONTINUE
CALL REQUES(RAD50('A1SF2'))
730 FORMAT(1X,'ERROR CODE=',I2)
END
```

OFSTF/ACIPS

```

C PROGRAM TO FIT POLYNOMIAL TO ALTERNATE SCAN OFFSET DATA STORED IN
C UNIT 10 BY PROGRAM OFFSEI GEN. INPUT DATA:
C CARD1: FIRST-POINT-ELEMENT-COORDINATE LAST-POINT
LOGICAL OPTION
DIMENSION ICORLM(2),XSCALE(10),OFFSLM(2),YSCALE(10)
DIMENSION DAIL(690),WORK(231)
DIMENSION COEF(21),LABEL(12)
DIMENSION MIN(10),MDUI(37)
DIMENSION ICOOR(230),OFFSET(230),WATE(230)
COMMON/BUFFER/WATE,OFFSET
COMMON/BUFF1/NCORMX,ICOOR
COMMON/NAVCOM/NAVX,INAV,IYR,IDAY,TOTLIN,DEGLIN,TOTIEL,DEGELE,PICLI
*N,PICELE,IMPSCLE,IOYR,IUDAY,IM,R1X,R1Y,R1Z,R1DX,R1DY,R1DZ,PICR,ROL
*L,YAW,PFIM(3),TMN(3),IMX(3),NLCOEF(2),NKCOEF(2),SCLL0(2),SCLL1(2),
*ELCOEF(11,2),SCLR0(2),SCLR1(2),ERCOEF(11,2),NASCEF,SCLAS0,SCLAS1,
*LELEMN,IELEMX,ASCOEF(16)
DATA ICORLM/0,2400/,OFFSLM/5.,15./
DATA LP/6/
DATA IT/5/
DATA MINDEG/15/
MENU=2
CALL INCOM(' ENTER LEFT, RIGHT ELEMENTS FROM PRINTER LISTING.',49,
*3,1,MIN,1,1)
IF(MENU.LE.0) GO TO 999
C READ LIMITS OF USEFUL DATA (ICOR LIMITS) FROM CARDS.
ILE=MIN(1)
IRE=MIN(2)
C READ IN OFFSETS AND WEIGHTS AND COORDINATES(ELEMENT NUMBER)
DO 10 I=1,NCORMX
IF(ICOOR(I).EQ.ILE) ILEAE=I
IF(ICOOR(I).EQ.IRE) IREAE=I
10 CONTINUE
NPIS=IREAE-ILEAE+1
C FIT LEAST SQUARES POLYNOMIAL.
IN=0
DO 25 I=ILEAE,IREAE
IN=IN+1
DAIL(IN)=ICOOR(I)
DAIL(IN+NPIS)=OFFSET(I)
DAIL(IN+2*NPIS)=WATE(I)
25 CONTINUE
CALL APCH(DAIL,NPIS,MINDEG,XD,X0,WORK,IER)
IF(IER.NE.0) GO TO 990
ETA=1.0E-3
EPS=1.0E-4
IOP=-1
CALL APFS(WORK,MINDEG,M,IOP,EPS,ETA,IER)
28 IF(IER)990,28,28
CONTINUE
NASCEF=M
SCLASJ=X0
SCLAS1=X0
LELEMN=ILE

```

ORIGINAL PAGE IS
OF POOR QUALITY

***** NRMLIZ/MCIDAS *****

```
@ELT,L AF,NRMLIZ/MCIDAS
ELT007 RLIB62 12/22-17:01:57-(0,)
000001      000      SUBROUTINE NRMLIZ(VX,VY,VZ,VNORM)
000002      000      VNORM=SQRT(VX**2+VY**2+VZ**2)
000003      000      VX=VX/VNORM
000004      000      VY=VY/VNORM
000005      000      VZ=VZ/VNORM
000006      000      RETURN
000007      000      END$
```

```
END ELT.
@HDG,P ***** OFFSETFIT *****
```

***** MINMIZ/MCIDAS *****

@ELT,L AF.MINMIZ/MCIDAS

ELT007 RLIB62 12/22-17:01:56-(0,)

```
000001      000      SUBROUTINE MINMIZ(PTIN,PTOUT,GNORM,VAL,ITN)
000002      000      C
000003      000      C THIS ROUTINE PERFORMS A MODIFIED NEWTON METHOD MINIMIZATION. IT
000004      000      C BEGINS AT THE POINT "PTIN" AND RETURNS IN "PTOUT" THE POINT
000005      000      C SELECTED AS THE OPTIMAL POINT, IN "GNORM" THE NQRM OF THE GRADIENT
000006      000      C OF S AT "PTOUT", AND IN "VAL" THE VALUE OF THE OBJECCTIVE FUNCTION
000007      000      C S AT "PTOUT". A POINT X(K+1) IS DEEMED OPTIPAL WHEN
000008      000      C  $ABS(S(X(K+1))-S(X(K))) <= (10**10)*ABS(S(X(K)))$ .
000009      000      C
000010      000      LOGICAL ALTRET
000011      000      DIMENSION PTIN(3),PTOUT(3)
000012      000      DIMENSION HESS(3,3),GRAD(3),PT(3),DIR(3)
000013      000      DATA CONVRG,ITERAT,EQUAL0/1.0E-18,25,1.0E-30/
000014      000      C
000015      000      ITN=0
000016      000      DO 5 I=1,3
000017      000      5 PT(I)=PTIN(I)
000018      000      OLDVAL=S(PT)
000019      000      DO 50 I=1,ITERAT
000020      000      ITN=ITN+1
000021      000      CALL PRTIAL(PT,GRAD,HESS)
000022      000      CALL INVERT(HESS,HESS,3,ALTRET)
000023      000      IF(ALTRET) GO TO 16
000024      000      DO 10 J=1,3
000025      000      DIR(J)=0
000026      000      DO 10 K=1,3
000027      000      10 DIR(J)=DIR(J)-HESS(J,K)*GRAD(K)
000028      000      DDD=0
000029      000      DO 15 J=1,3
000030      000      15 DDD=DDD+DIR(J)*GRAD(J)
000031      000      IF(DDD.LT.-EQUAL0)GOTO 25
000032      000      IF(DDD.GT.+EQUAL0)GOTO 19
000033      000      16 DDD=0
000034      000      DO 17 J=1,3
000035      000      DDD=DDD+GRAD(J)**2
000036      000      17 DIR(J)=-GRAD(J)
000037      000      GOTO 25
000038      000      19 DO 20 J=1,3
000039      000      20 DIR(J)=-DIR(J)
000040      000      25 CALL LS(PT,PTOUT,VAL,DDD,DIR)
000041      000      IF(ABS(VAL-OLDVAL).LE.CONVRG*ABS(OLDVAL)) GO TO 60
000042      000      OLDVAL=VAL
000043      000      DO 30 J=1,3
000044      000      30 PT(J)=PTOUT(J)
000045      000      50 CONTINUE
000046      000      60 GNORM=0
000047      000      DO 65 I=1,3
000048      000      65 GNORM=GNORM+GRAD(I)**2
000049      000      GNORM=SQRT(GNORM)
000050      000      RETURN
000051      000      ENDS
```

END ELT.

@HDG,P ***** NRMLIZ/MCIDAS *****

***** LS/MCIDAS *****

@ELT,L AF.LS/MCIDAS

ELT007 RLIB62 12/22-17:01:56-(0,)

```
000001 000 SUBROUTINE LS(X,Y,VAL,DD,DIR)
000002 000 C
000003 000 C THIS ROUTINE PERFORMS AN ARMIJO LINE SEARCH FROM THE POINT "X"
000004 000 C IN THE DIRECTION "DIR" AND RETURNS THE SELECTED POINT IN "Y"
000005 000 C AND THE OBJECTIVE FUNCTION VALUE S(Y) IN "VAL". ON CALL, "DD"
000006 000 C IS THE UNNORMALIZED DIRECTIONAL DERIVATIVE <GRAD(S(X)),DIR>.
000007 000 C THIS LINE SEARCH ROUTINE RETURNS IN Y THE POINT  $X+2^{**}(-N)*DIR$ ,
000008 000 C WHERE N IS THE LEAST NONNEGATIVE INTEGER SUCH THAT
000009 000 C  $-S(2^{**}(-N)*DIR)$  REPRESENTS AT LEAST 40% OF THE FUNCTIONAL DROP
000010 000 C IN THE LINEARIZATION OF S AT X IN MOVING FROM X TO  $X+2^{**}(-N)*DIR$ .
000011 000 C
000012 000 DIMENSION X(3),Y(3),DIR(3)
000013 000 DATA FAC,WALK/5.0E-1,1.0E-5/
000014 000 RLAM=1.0
000015 000 TSTVAL=.4*RLAM*ABS(DD)
000016 000 OLDVAL=S(X)
000017 000 1 IF(RLAM.LT.WALK)RETURN
000018 000 DO 2 I=1,3
000019 000 2 Y(I)=X(I)+RLAM*DIR(I)
000020 000 VAL=S(Y)
000021 000 IF(OLDVAL-VAL.GE.TSTVAL)RETURN
000022 000 TSTVAL=FAC*TSTVAL
000023 000 RLAM=FAC*RLAM
000024 000 GOTO 1
000025 000 ENDS
```

END ELT.

@HDG,P ***** MINMIZ/MCIDAS *****

ORIGINAL PAGE IS
OF POOR QUALITY

***** LATSF/MCIDAS *****

000170 000 ENDS
000171 000 \$FILEMA
000172 000 DELETE LDATSF, GORP
000173 000 \$INCLUDE IFLD
000174 000 \$CATALOG
000175 000 NAME=LDATSF, S, R, W, D
000176 000 TYPE=FG
000177 000 LIB=ATSFLB, LL
000178 000 BEGIN
000179 000 \$EOJ

END ELT.

@HDG, P ***** LDATSF *****

ORIGINAL PAGE IS
OF POOR QUALITY

***** LATSF/MCIDAS *****

```
000113      000      CALL EMESS(3HREQ,0)
000114      000      RETURN
000115      000      921  WRITE(LP,701)
000116      000      701  FORMAT(1X,"E-O-F TERMINATES LOAD")
000117      000      CALL MARKOK(IAREA)
000118      000      CALL MARKOK(1RAREA)
000119      000      CALL REW(LUN)
000120      000      RETURN
000121      000      922  CONTINUE
000122      000      CALL EMESS(3HREQ,0)
000123      000      RETURN
000124      000      END
000125      000      SUBROUTINE LINGRB(INDATA,SDIR,ELE,NELES,BDF,OUTDAT)
000126      000      IMPLICIT INTEGER(A-Z)
000127      000      DIMENSION INDATA(1),OUTDAT(1)
000128      000      DIMENSION TDAT(2406),DLELE(672)
000129      000      COMMON/OFFSET/DLELE
000130      000      DATA WOFF/6/,NE/2406/
000131      000      IF(BDF.NE.1) CALL EMESS(3HREQ,BDF)
000132      000      IF(BDF.NE.1) CALL EXIT
000133      000      IO2=ELE-1
000134      000      CALL CRKATS(NE,INDATA,TDAT)
000135      000      IF(SDIR.EQ.1) GO TO 100
000136      000      C      SHIFT EVEN SCANS
000137      000      DO 50 I=1,NELES
000138      000      DE=I+IO2+DLELE(I)+WOFF
000139      000      OUTDAT(I)=TDAT(DE)
000140      000      50    CONTINUE
000141      000      CALL PACK(NELES,OUTDAT,OUTDAT)
000142      000      RETURN
000143      000      100  CONTINUE
000144      000      C      LOAD ODD SCANS
000145      000      DO 150 I=1,NELES
000146      000      OUTDAT(I)=TDAT(I+IO2+WOFF)
000147      000      150  CONTINUE
000148      000      CALL PACK(NELES,OUTDAT,OUTDAT)
000149      000      RETURN
000150      000      END
000151      000      SUBROUTINE GENOFF(IELE,NELES)
000152      000      COMMON/NAVCOM/NAVN,INAV,IYR,IDAY,TOTLIN,DEGLIN,TOTIEL,DEGELE,PICLI
000153      000      *N,PICELE,TMPSC,IOYR,IODAY,TM,R1X,R1Y,R1Z,R1DX,R1DY,R1DZ,PITCH,ROL
000154      000      *L,YAW,PTIM(3),TMX(3),TMX(3),NLCOEF(2),NRCOEF(2),SCLLG(2),SCLL1(2),
000155      000      *ELCOEF(11,2),SCLRO(2),SCLR1(2),ERCOEF(11,2),NASCEF,SCLAS0,SCLAS1,
000156      000      *IELEMN,IELEMX,ASCOEF(16)
000157      000      COMMON/OFFSET/IDLELE(672)
000158      000      DATA NOMOFF/8/
000159      000      CALL RCOM
000160      000      NEND=IELE+NELES-1
000161      000      DO 100 I=1,NELES
000162      000      IDLELE(I)=NOMOFF
000163      000      IELE=IELE+I-1
000164      000      IF(IELE.LT.IELEMN.OR.IELEMX.LT.IELE)GO TO 100
000165      000      T=IELE*SCLAS1+SCLAS0
000166      000      CALL CNPS(Y,T,ASCOEF,NASCEF)
000167      000      IDLELE(I)=Y+0.5
000168      000      100  CONTINUE
000169      000      RETURN
```

ORIGINAL PAGE IS
OF POOR QUALITY

***** LATSF/MCIDAS *****

```

000056      000      IFILE=IFILE-1
000057      000      IF(IFILE.LT.1)GO TO 502
000058      000      GO TO 922
000059      000      502  CONTINUE
000060      000      C      ADVANCE TO FIRST SCAN TO INPUT
000061      000      CALL READW(LUN,NWA,IARRAY)
000062      000      CALL READW(LUN,NWA,IARRAY)
000063      000      DO 510 I=1,1200
000064      000      CALL READW(LUN,NWA,IARRAY)
000065      000      CALL CRKTHR(195,IARRAY,IAROW)
000066      000      INMS=IAROW(195)
000067      000      IF(INMS.LE.IUMS) GO TO 511
000068      000      510  CONTINUE
000069      000      GO TO 922
000070      000      511  CALL BSR(LUN)
000071      000      C      START MAIN LOOP TO READ DATA IN AND STORE
000072      000      C      READ A SCAN
000073      000      601  CALL READW(LUN,NWA,IARRAY)
000074      000      CALL CRKTHR(195,IARRAY,IAROW)
000075      000      INMS=IAROW(195)
000076      000      IF(INMS.LT.IUMS) GO TO 690
000077      000      C      MAP SCAN NUMBER TO AREA ROW
000078      000      L1=(1200-INMS)*2+(3-2)
000079      000      L2=(1200-INMS)*2+(3-1)
000080      000      LA1=L1-IULINE
000081      000      LA2=L2-IULINE
000082      000      LR1=MOD(LA1,IBDF)
000083      000      LR2=MOD(LA2,IBDF)
000084      000      IF(LR1.NE.0 .AND. LR2.NE.0) GO TO 601
000085      000      IROW1=LA1/IBDF
000086      000      IROW2=LA2/IBDF
000087      000      NS=NSECL(NELES)
000088      000      ISD=MOD(INMS,2)
000089      000      ISEC1=NS*IROW1
000090      000      ISEC2=NS*IROW2
000091      000      C      PICK OUT LINE SEGMENT
000092      000      C      FIRST VISIBLE LINE
000093      000      IF(IFVIS.AND.LR1.EQ.0) CALL LINGRB(IARRAY(2497),ISD,IUELE,NELES,IB
000094      000      *DF,IAROW)
000095      000      IF(IFVIS.AND.LR1.EQ.0) CALL WRITA(IAREA,ISEC1,NS*112,IAROW)
000096      000      C      SECOND VISIBLE LINE
000097      000      IF(IFVIS.AND.LR2.EQ.0)CALL LINGRB(IARRAY(1297),ISD,IUELE,NELES,IBD
000098      000      *F,IAROW)
000099      000      IF(IFVIS.AND.LR2.EQ.0) CALL WRITA(IAREA,ISEC2,NS*112,IAROW)
000100      000      C      INFRARED
000101      000      IF(IFIR) CALL LINGRB(IARRAY(97),ISD,IUELE,NELES,IBDF,IAROW)
000102      000      IF(IFIR.AND.LR1.EQ.0) CALL WRITA(IRAREA,ISEC1,NS*112,IAROW)
000103      000      IF(IFIR.AND.LR2.EQ.0) CALL WRITA(IRAREA,ISEC2,NS*112,IAROW)
000104      000      GO TO 601
000105      000      690  CONTINUE
000106      000      CALL MARKOK(IAREA)
000107      000      CALL MARKOK(IRAREA)
000108      000      CALL REW(LUN)
000109      000      RETURN
000110      000      910  CONTINUE
000111      000      912  CONTINUE
000112      000      913  CONTINUE

```

***** LATSF/MCIDAS *****

@ELT,L AF.LATSF/MCIDAS

ELT007 RLIB62 12/22-17:01:53-(0,)

000001 000 SJOB LDATSF U3200

000002 000 \$OPTION .8,9,13,20

000003 000 SFORTRAN

000004 000 SUBROUTINE MAIN

000005 000 C PROGRAM TO READ IMAGES FROM ATS-6 TAPES.

000006 000 LOGICAL IFVIS,IFIR,OPTION

000007 000 DIMENSION MIN(12),IARRAY(3732),IAROW(672)

000008 000 DATA LUN/10/,LP/6/,ICR/5/

000009 000 DATA MIN/6HLDATSF,10*0/,NWA/3732/

000010 000 C PICK UP INPUT PARAMETERS

000011 000 CALL IQ(MIN)

000012 000 C INPUT: SSYYDDD HHMMSS AREA LINE ELEMENT

000013 000 IDAY=MIN(1)

000014 000 ITIME=MIN(2)

000015 000 IAREA=MIN(3)

000016 000 LINE=MIN(4)

000017 000 IELE=MIN(5)

000018 000 IBDF=1

000019 000 IREEL=0

000020 000 KEY=3H

000021 000 C COMPUTE DERIVED PARAMETERS

000022 000 ISS=IDAY/100000

000023 000 IFILE=1

000024 000 IVSS=(ISS/2)*2

000025 000 IRSS=IVSS+1

000026 000 IFVIS=ISS.EQ.IVSS

000027 000 IFIR=ISS.EQ.IRSS.OR.IAREA.LT.9

000028 000 IRAREA=IAREA

000029 000 IF(IFIR.AND.IFVIS) IRAREA=IAREA+8

000030 000 C PICK UP AREA SIZE

000031 000 CALL HOWBIG(IAREA,NLINS,NELES)

000032 000 IF(NELES.GT.672) GO TO 922

000033 000 C COMPUTE UPPER LEFT COORDINATES

000034 000 IULINE=LINE

000035 000 IUELE=IELE

000036 000 IF(OPTION(KEY,3H C)) IULINE=LINE-(NLINS/2)*IBDF

000037 000 IF(OPTION(KEY,3H C)) IUELE=IELE-(NELES/2)*IBDF

000038 000 IUMS=1200-(IULINE-1)/2

000039 000 ILLINE=IULINE+(NLINS-1)*IBDF

000040 000 ILLMS=1200-(ILLINE-1)/2

000041 000 C CREATE IR AREA FOR COMBINED LOAD

000042 000 IF(IFIR.AND.IFVIS) CALL ARASIZ(IAREA+8,NLINS,NELES)

000043 000 C ESTABLISH AREA DIRECTORY

000044 000 IGE=0

000045 000 CALL ENAREA(IAREA,IREEL,IDAY,ITIME,IULINE,IUELE,IBDF,IBDF,IGE)

000046 000 IRREEL=IRSS*100000+MOD(IREEL,100000)

000047 000 IF(IREEL.EQ.0) IRREEL=0

000048 000 IRDAY=IRSS*100000+MOD(IDAY,100000)

000049 000 IF(IFVIS.AND.IFIR) CALL ENAREA(IAREA+8,IRREEL,IRDAY,ITIME,IULINE,I

000050 000 *UELE,IBDF,IBDF,IGE)

000051 000 C GENERATE OFFSET TABLE

000052 000 CALL GENOFF(IUELE,NELES)

000053 000 IRR=MAXO(1,MOD(IREEL,100000))

000054 000 CALL GTAP(14,IRR,LUN)

000055 000 C ADVANCE TO FILE

ORIGINAL PAGE IS
OF POOR QUALITY

LATS/ AOIPS

```

WRITE(IT,711)
711  FORMAT(' TAPE SEARCH STARTS')
     CALL IOIPBK(LUN,+2,1STAT)
     DO 510 I=1,1200
     CALL IOIPIN(LUN,IARRAY,NWA,LE,1STAT)
     CALL CRKTHR(195,IARRAY,IAROW)
     INMS=IAROW(195)
     IF(INMS.LE.IUMS) GO TO 511
510  CONTINUE
     GO TO 922
     511 CALL IOIPSR(LUN,-1,1STAT)
     WRITE(II,712)
712  FORMAT(' IMAGE LOAD STARTS')
C    START MAIN LOOP TO READ DATA IN AND STORE
C    READ A SCAN
601  CALL IOIPIN(LUN,IARRAY,NWA,LE,1STAT)
     CALL CRKTHR(195,IARRAY,IAROW)
     INMS=IAROW(195)
     IF(INMS.LT.IUMS) GO TO 690
C    MAP SCAN NUMBER TO AREA ROW
     L1=(1200-INMS)*2+(3-2)
     L2=(1200-INMS)*2+(3-1)
     LA1=L1-IULINE
     LA2=L2-IULINE
     LR1=MOD(LA1,IBDF)
     LR2=MOD(LA2,IBDF)
     IF(LR1.NE.0 .AND. LR2.NE.0) GO TO 601
     IROW1=LA1/IBDF
     IROW2=LA2/IBDF
     ISD=MOD(INMS,2)
     ISEC1=NS*IROW1
     ISEC2=NS*IROW2
C    PICK OUT LINE SEGMENT
C    FIRST VISIBLE LINE
     IF(IFVIS.AND.LR1.EQ.0) CALL LINGRB(IARRAY(3745),ISD,IUELE,NELES,IB
*DF,IAROW)
     IF(IFVIS.AND.LR1.EQ.0) CALL WRITE(LRNVIS,IAROW,0)
C    SECOND VISIBLE LINE
     IF(IFVIS.AND.LR2.EQ.0) CALL LINGRB(IARRAY(1945),ISD,IUELE,NELES,IB
*DF,IAROW)
     IF(IFVIS.AND.LR2.EQ.0) CALL WRITE(LRNVIS,IAROW,0)
C    INFRARED
     IF(IFIR) CALL LINGRB(IARRAY(145),ISD,IUELE,NELES,IBDF,IAROW)
     IF(IFIR.AND.LR1.EQ.0) CALL WRITE(LRNIR,IAROW,0)
     IF(IFIR.AND.LR2.EQ.0) CALL WRITE(LRNIR,IAROW,0)
     GO TO 601
690  CONTINUE
922  CONTINUE
     CALL CLOSEF(LRNVIS)
     CALL CLOSEF(LRNIR)
     CALL IOIPRW(LUN)
     GO TO 999
999  CONTINUE
     CALL REQRES(RAD50('AIFS2'))
     END

```

LATSF/AOIPS

```

ILMS=1200-(IULINE-1)/2
C ESTABLISH AREA DIRECTORY
DO 10 I=1,256
10 IDIR(I)=0
   IDIR(1)='AT'
   IDIR(2)='S6'
   IDIR(3)='V'
   IDIR(4)='IS'
   IDIR(5)='E.'
   IDIR(6)='H.'
   IDIR(7)='L.'
   IDIR(8)=' '
   IDIR(9)='AT'
   IDIR(10)='S6'
   IDIR(11)=' '
   IDIR(12)='E.'
   IDIR(13)='H.'
   IDIR(14)='T.'
   IDIR(15)=' '
   IDIR(16)=' '
DO 12 I=12,1,-1
12 IF(IDAY.GT.MODDAY(I))GO TO 13
13 CONTINUE
   MUN=I-
   IDIR(19)=IYR*100+MON
   IDIR(20)=(IDAY-MODDAY(MON))*100+IFIX(PTIM(IPIC)/60.)
   IM=PTIM(IPIC)
   IS=PIFM(IPIC)+60.-IM*60.
   IS=MOD(IS,60)
   IM=MOD(IM,60)
   IDIR(21)=IM*100+IS
   IDIR(24)=1
   IDIR(25)=1
   IDIR(26)=IPIC
   IDIR(29)='EF'
   IDIR(30)='IC'
   IDIR(31)=1
   IDIR(32)=LRNVIS
   IDIR(33)=512
   IDIR(34)=513
   IDIR(37)=512
   IDIR(38)=512
   IDIR(39)=IUELE
   IDIR(40)=IULINE
   IDIR(41)=1
   IDIR(42)=1
   IDIR(43)=1
   IDIR(44)=1
   IDIR(45)=1
   IDIR(46)=1
   IDIR(47)=1
   IDIR(48)=1
   IDIR(51)=1000*(IMUNIT+1)
   IDIR(53)=1
   NWD=(NELES+1)/2
   CALL OPEN(LRNVIS,NLINS+1,NWD)
   CALL OPEN(LRNIR,NLINS+1,NWD)
   CALL UBLWRP(LRNVIS,I DIR,256)
   IDIR(32)=LRNIR
   IDIR(3)=' '
   IDIR(4)='IR'
   CALL UBLWRP(LRNIR,I DIR,256)
C GENERATE OFFSET TABLE
CALL GENOFF(IUELE,NELES)
CALL ASNUN(LUN,'M',IMUNIT)
C ADVANCE TO FIRST SCAN TO INPUT

```

ORIGINAL PAGE I:
OF POOR QUALITY

LATS/ACOIPS

```

C PROGRAM TO READ IMAGES FROM ATS-6 TAPES.
  INTEGER*4 ITIMX
  LOGICAL IFVIS,IFIR,OPTION
  DIMENSION MIN(10),RMIN(10),IARRAY(5600)
  EQUIVALENCE (IDIR,IAROW)
  DIMENSION IDIR(256),IAROW(456)
  DIMENSION MUDAY(12)
  COMMON/NAVCOM/NAVN,INAV,IYR,1DAY,TOTLIN,DEGLIN,TOTIEL,DEGELE,PICLI
  *N,PICLLE,IMPSCLE,IUYR,1ODAY,FM,R1X,R1Y,R1Z,R1DX,R1DY,R1DZ,PITCH,ROU
  *L,YAW,PIIM(3),PMN(3),IMX(3),NLCOEF(2),NRCOEF(2),SCLL0(2),SCLL1(2),
  *ELCOEF(11,2),SCLR0(2),SCLR1(2),ERCOEF(11,2),NASCLEF,SCLAS0,SCLAS1,
  *IELEMN,IELEMX,ASCDEF(16)
  DATA MUDAY/0.31,59.90,120,151,181,212,243,273,304,334/
  DATA LUN/*/,LP/6/,ICR/5/
  DATA LI/5/,NELES/512/
  DATA NLINS/512/
C PICK UP INPUT PARAMETERS
  NWA=5600
  MENU=1
  CALL INCOM(' ENTER PICTURE TIME (HHMMSS)',28,1,1,RMIN,MENU,3,1)
  IF(MENU.LE.0) GO TO 999
  IITIMX=RMIN(1)
  PI=FTIME(IITIMX)
  DO 5 I=1,3
5 IF(PI.EQ.PIIM(I)) GO TO 6
  WRITE(IT,710)IITIMX
710 FORMAT(IX,'NAVCOM NOT INITIALIZED FOR ',I7)
  GO TO 999
6 CONTINUE
  IPIC=1
  MENU=2
  CALL INCOM(' ENTER START LINE AND ELEMENT',29,3,1,MIN,MENU,1,1)
  IF(MENU.LE.0) GO TO 999
  LINE=MIN(1)
  IELE=MIN(2)
  MENU=1
  CALL INCOM(' ENTER ZOOM AREA(1-7)',21,5,1,MIN,MENU,1,1)
  IF(MENU.LE.0) GO TO 999
  IAREA=MIN(1)
  LRNVIS=IAREA+5+(IPIC-1)*7
  LRNIR=LRNVIS+21
  MENU=1
  CALL INCOM(' ENTER TAPE UNIT (0,1)',22,7,1,MIN,MENU,1,1)
  IF(MENU.LE.0) GO TO 999
  IMJN11=MIN(1)
  IBDF=1
  IFVIS=.TRUE.
  IFIR=.TRUE.
C COMPUTE UPPER LEFT COORDINATES
  IULINE=LINE
  IUELE=IELE
  IUMS=1200-(IULINE-1)/2
  ILLINE=IULINE+(NLINS-1)*IBDF

```

***** INVERT/MCIDAS *****

@ELT,L AF.INVERT/MCIDAS

ELT007 RLIB62 12/22-17:01:52-(0,)

```
000001      000      SUBROUTINE INVERT(AA,B,N,ALTRET)
000002      000      C
000003      000      C      THIS ROUTINE RETURNS IN B THE INVERSE OF THE N-DIMENSIONAL MATRIX AA.
000004      000      C      IF AA IS SINGULAR, A RETURN IS TAKEN THROUGH LABEL $.
000005      000      C
000006      000      LOGICAL ALTRET,LOGTMP
000007      000      DIMENSION AA(N,N),B(N,N),A(3,3)
000008      000      DATA TV/1.0E35/
000009      000      ALTRET=.FALSE.
000010      000      DO 1 I=1,N
000011      000      DO 1 J=1,N
000012      000      1      A(I,J)=AA(I,J)
000013      000      DO 2 I=1,N
000014      000      DO 2 J=1,N
000015      000      B(I,J)=0
000016      000      2      IF(I.EQ.J)B(I,J)=1.0
000017      000      LIM=N-1
000018      000      DO 4 I=1,LIM
000019      000      IF(ABS(A(I,I)).LT.1.0E-30) CALL FLIP(A,B,I,N,ALTRET)
000020      000      LOGTMP=ALTRET
000021      000      ALTRET=.FALSE.
000022      000      IF(LOGTMP) GO TO 101
000023      000      LIM2=I+1
000024      000      DO 4 J=LIM2,N
000025      000      IF(TV*ABS(A(I,I)).LE.ABS(A(J,I))) ALTRET=.TRUE.
000026      000      IF(TV*ABS(A(I,I)).LE.ABS(A(J,I))) RETURN
000027      000      FACTOR=A(J,I)/A(I,I)
000028      000      DO 3 K=LIM2,N
000029      000      3      A(J,K)=A(J,K)-FACTOR*A(I,K)
000030      000      DO 4 K=1,N
000031      000      4      B(J,K)=B(J,K)-FACTOR*B(I,K)
000032      000      DO 5 I=N,2,-1
000033      000      LIM3=I-1
000034      000      DO 5 J=LIM3,1,-1
000035      000      IF(TV*ABS(A(I,I)).LE.ABS(A(J,I))) ALTRET=.TRUE.
000036      000      IF(TV*ABS(A(I,I)).LE.ABS(A(J,I))) RETURN
000037      000      FACTOR=A(J,I)/A(I,I)
000038      000      DO 5 K=1,N
000039      000      5      B(J,K)=B(J,K)-FACTOR*B(I,K)
000040      000      DO 6 I=1,N
000041      000      FACTOR=A(I,I)
000042      000      DO 6 J=1,N
000043      000      IF(TV*ABS(FACTOR).LE.ABS(B(I,J))) ALTRET=.TRUE.
000044      000      IF(TV*ABS(FACTOR).LE.ABS(B(I,J))) RETURN
000045      000      6      B(I,J)=B(I,J)/FACTOR
000046      000      RETURN
000047      000      101 ALTRET=.TRUE.
000048      000      RETURN
000049      000      ENDS
```

END ELT.

@HDG,P ***** LATSF/MCIDAS *****

ORIGINAL PAGE
OF POOR QUALITY

***** GASORB/MCIDAS *****

@ELT,L AF.GASORB/MCIDAS

```
ELT007 RLIB62 12/22-17:01:51-(0,)  
000001 000 SUBROUTINE GASORB(R1,T1,R2,T2)  
000002 000 REAL KE,L,M,MU  
000003 000 DIMENSION R1(3),R2(3)  
000004 000 COMMON/NAVCON/NAVN,INAV,IYR,IDAY,TOTLIN,DEGLIN,TOTIEL,DEGELE,PICLI  
000005 000 *N,PICELE,TMPSCLE,IYR,IODAY,TM,R1X,R1Y,R1Z,R1DX,R1DY,R1DZ,PITCH,ROL  
000006 000 *L,YAW,PTIM(3),TMN(3),TMX(3),NLCOEF(2),NRCOEF(2),SCLLO(2),SCLL1(2),  
000007 000 *ELCOEF(11,2),SCLRO(2),SCLR1(2),ERCOEF(11,2),NASCEF,SCLAS0,SCLAS1,  
000008 000 *IELEMN,IELEMX,ASCOEF(16)  
000009 000 DATA RE,KE,MU/6378.15,0.07436574,1.0/  
000010 000 TM=T1  
000011 000 DO 5 I=1,3  
000012 000 R1(I)=R1(I)/RE  
000013 000 R2(I)=R2(I)/RE  
000014 000 5 CONTINUE  
000015 000 R1X=R1(1)  
000016 000 R1Y=R1(2)  
000017 000 R1Z=R1(3)  
000018 000 R1NORM=SQRT(R1(1)**2+R1(2)**2+R1(3)**2)  
000019 000 R2NORM=SQRT(R2(1)**2+R2(2)**2+R2(3)**2)  
000020 000 TAU=KE*(T2-T1)  
000021 000 R1R2NM=R1NORM*R2NORM  
000022 000 COSANM=(R1(1)*R2(1)+R1(2)*R2(2)+R1(3)*R2(3))/R1R2NM  
000023 000 CSHFAN=SQRT((1+COSANM)/2)  
000024 000 L=(R1NORM+R2NORM)/(4*SQRT(R1R2NM)*CSHFAN)-.5  
000025 000 M=(MU*TAU**2)/(2*SQRT(R1R2NM)*CSHFAN)**3  
000026 000 YU=1  
000027 000 10 YL=YU  
000028 000 XL=M/YL**2-L  
000029 000 CHFEAN=1-2*XL  
000030 000 SHFEAN=SQRT(4*XL*(1-XL))  
000031 000 ECANOM=2*ATAN2(SHFEAN,CHFEAN)  
000032 000 XU=(ECANOM-SIN(ECANOM))/SHFEAN**3  
000033 000 YU=1+XU*(L+XL)  
000034 000 IF(ABS(YU-YL).GE.1.0D-6)GOTO10  
000035 000 YL=YU.  
000036 000 A=((TAU*SQRT(MU))/(2*YL*SQRT(R1R2NM)*CSHFAN*SHFEAN))**2  
000037 000 F=1-A/R1NORM*(1-COS(ECANOM))  
000038 000 G=TAU-A**1.5/SQRT(MU)*(ECANOM-SIN(ECANOM))  
000039 000 R1DX=(R2(1)-F*R1(1))/G  
000040 000 R1DY=(R2(2)-F*R1(2))/G  
000041 000 R1DZ=(R2(3)-F*R1(3))/G  
000042 000 RETURN  
000043 000 END
```

END ELT.

@HDG,P ***** INVERT/MCIDAS *****

***** FTIME/MCIDAS *****

@ELT,L AF.FTIME/MCIDAS

ELT007 RLIB62 12/22-17:01:51-(0,)

```
000001      000      FUNCTION FTIME(ITIME)
000002      000      IH=ITIME/10000
000003      000      HRS=IH*60.
000004      000      AMNS=FLOAT((ITIME-(ITIME/10000)*10000)/100)
000005      000      SECS=FLOAT(MOD(ITIME,100))/60.
000006      000      FTIME=HRS+AMNS+SECS
000007      000      RETURN
000008      000      ENDS
```

END ELT.

@HDG,P ***** GASORB/MCIDAS *****

ORIGINAL PAGE IS
OF POOR QUALITY

***** FLIP/MCIDAS *****

@ELT,L AF.FLIP/MCIDAS

ELT007 RLIB62 12/22-17:01:50-(0,)

```
000001      000      SUBROUTINE FLIP(A,B,I,N,ALTRET)
000002      000      C
000003      000      C THIS ROUTINE IS CALLED ONLY BY SUBROUTINE INVERT AND IS USED TO
000004      000      C PERFORM AN ELEMENTARY ROW OPERATION ON MATRICES A AND B.
000005      000      C
000006      000      LOGICAL ALTRET
000007      000      DIMENSION A(N,N),B(N,N)
000008      000      ALTRET=.FALSE.
000009      000      LIM=I+1
000010      000      DO 2 L=LIM,N
000011      000      IF( ABS(A(L,1)).LT.1.0E-32)GOTO 2
000012      000      DO 1 M=1,N
000013      000      A(I,M)=A(I,M)+A(L,M)
000014      000      B(I,M)=B(I,M)+B(L,M)
000015      000      RETURN
000016      000      2 CONTINUE
000017      000      ALTRET=.TRUE.
000018      000      RETURN
000019      000      END$
```

END ELT.

@HDG,P ***** FTIME/MCIDAS *****

***** FLALO/MCIDAS *****

2ELT,L AF.FLALO/MCIDAS

ELT007 RLIB62 12/22-17:01:49-(0,)

```
000001      000          FUNCTION FLALO(N)
000002      000          IF (M .LT. 0)GO TO 1
000003      000          N=M
000004      000          X=1.0
000005      000          GO TO 2
000006      000      1      N=-M
000007      000          X=-1.0
000008      000      2      FLALO=FLOAT(N/10000)+FLOAT(MOD(N/100,100))/60.+FLOAT(MOD(N,100))/
000009      000          * 3600.
000010      000          FLALO=FLALO*X
000011      000          RETURN
000012      000          ENDS
```

END. ELT.

2HDG,P ***** FLIP *****

ORIGINAL PAGE IS
OF POOR QUALITY

***** ES/MCIDAS *****

@ELT,L AF,ES/MCIDAS

ELT007 RLIB62 12/22-17:01:48-(G,)

```
000001 000 SUBROUTINE ES(PTIME,XLAT,XLON,XLIN,XELE)
000002 000 COMMON/NAVCOM/NAVN,INAV,IYR,IDAY,TOTLIN,DEGLIN,TOTIEL,DEGELE,PICLI
000003 000 *N,PICELE,TMPSCL,IOYP,IOBAY,IM,R1X,R1Y,R1Z,R1DX,R1DY,R1DZ,PITCH,ROL
000004 000 *L,YAW,PTIM(3),TMN(3),TMX(3),NLCOEF(2),NRCOEF(2),SCLLO(2),SCLL1(2),
000005 000 *ELCOEF(11,2),SCLRO(2),SCLR1(2),ERCOEF(11,2),NASCEF,SCLAS0,SCLAS1,
000006 000 *IELEMN,IELEMN,ASCOEF(16)
000007 000 DATA INIT/0/
000008 000 ALON=XLON
000009 000 ALAT=XLAT
000010 000 TIME=PTIME
000011 000 IDIR=1
000012 000 ALINSV=0
000013 000 AELESV=0
000014 000 DO 100 II=1,5
000015 000 CALL ERTOER(ALAT,ALON,X1ER,X2ER,X3ER,IDIR)
000016 000 CALL ERTOST(X1ER,X2ER,X3ER,X1,X2,X3,IDIR,TIME)
000017 000 CALL STTOLV(X1,X2,X3,IDIR,TIME)
000018 000 C BC SAME AS LV HERE. I
000019 000 CALL BCTOPF(X1,X2,X3,IDIR)
000020 000 CALL PFTOTC(ALIN,AELE,X1,X2,X3,IDIR,INIT)
000021 000 CALL EDGCR(PTIME,ALIN,DELLIN,DELELE)
000022 000 AELEC=AELE+DELELE
000023 000 ALINC=ALIN+DELLIN
000024 000 IF(ABS(ALINC-ALINSV).LE.0.5) GO TO 150
000025 000 ALINSV=ALINC
000026 000 AELESV=AELEC
000027 000 ISCAN=1200-(IFIX(ALIN-1))/2
000028 000 TIME=PTIME+ISCAN*TMPSCL
000029 000 100 CONTINUE
000030 000 150 CONTINUE
000031 000 XLIN=ALINC
000032 000 XELE=AELEC
000033 000 RETURN
000034 000 END
```

END ELT.

@HDG,P ***** FLALO *****

***** ERTOST/MCIDAS *****

```

@ELT,L AF.ERTOST/MCIDAS
ELT007 RLIB62 12/22-17:01:47-(0,)
000001 000 SUBROUTINE ERTOST(XE,YE,ZE,X,Y,Z,IDIR,TIME)
000002 000 C PARAMETER LIST
000003 000 C XE,YE,ZE=EARTH COORDS OF LANDMARK
000004 000 C X,Y,Z=POINTING VEC IN INERTIAL COORDS TO LANDMARK
000005 000 C IF IDIR=1, EARTH TO POINTING
000006 000 C IF IDIR=2, POINTING TO EARTH
000007 000 C ITIME=HHMMSS OF CURRENT POINTING VECTOR
000008 000 COMMON/NAVCOM/NAVN,INAV,IYR,IDAY,TOTLIN,DEGLIN,TOTIEL,DEGELE,PICLI
000009 000 *N,PICELE,TMPSCL,IOYR,IODAY,TI,R1X,R1Y,R1Z,R1DX,R1DY,R1DZ,PITCH,ROL
000010 000 *L,YAW,PTIM(3),TMN(3),TMX(3),NLCOEF(2),NRCOEF(2),SCLLO(2),SCLL1(2),
000011 000 *ELCOEF(11,2),SCLRO(2),SCLR1(2),ERCOEF(11,2),NASCEF,SCLAS0,SCLAS1,
000012 000 *IELEMN,IELEMN,ASCOEF(16)
000013 000 DDD=FLOAT(MOD(IDAY,1000))
000014 000 A=6378.15
000015 000 B=6350.77
000016 000 R1=99.59477026
000017 000 R2=.985647336
000018 000 R3=.2506844773
000019 000 PI=3.14159265
000020 000 RDPDG=PI/180.0
000021 000 R=(R1+R2*DDD+R3*TIME)
000022 000 R=AMOD(R,360.)*RDPDG
000023 000 CALL ORBIT(XS,YS,ZS,TIME)
000024 000 CR=COS(R)
000025 000 SR=SIN(R)
000026 000 IF(IDIR .EQ. 2)GO TO 10
000027 000 X1=CR*XE-SR*YE
000028 000 Y1=SR*XE+CR*YE
000029 000 Z1=ZE
000030 000 X=X1-XS
000031 000 Y=Y1-YS
000032 000 Z=Z1-ZS
000033 000 CALL NRMLIZ(X,Y,Z,RNORM)
000034 000 RETURN
000035 000 10 CONTINUE
000036 000 F=B**2/A**2
000037 000 AQ=F+(1.-F)*Z**2
000038 000 BQ=2.*((X*XS+Y*YS)*F+Z*ZS)
000039 000 CQ=(XS**2+YS**2)*F+ZS**2-B**2
000040 000 RAD=BQ**2-4.*AQ*CQ
000041 000 IF(RAD.LT.0.) GO TO 15
000042 000 S=-(BQ+SQRT(RAD))/(2.*AQ)
000043 000 X2=XS+X*S
000044 000 Y2=YS+Y*S
000045 000 Z2=ZS+Z*S
000046 000 XE=CR*X2+SR*Y2
000047 000 YE=-SR*X2+CR*Y2
000048 000 ZE=Z2
000049 000 RETURN
000050 000 15 WRITE(6,1000)
000051 000 1000 FORMAT(1X,'THE SUBROUTINE ERTOST (IDIR=2) HAS RECEIVED BAD
000052 000 * INPUT DATA.')
000053 000 RETURN
000054 000 ENDS
```

ORIGINAL PAGE IS
OF POOR QUALITY

***** ERTOER/MCIDAS *****

@ELT,L AF.ERTOER/MCIDAS

ELT007 RLIB62 12/22-17:01:46-(0,)

```
000001      000      SUBROUTINE ERTOER(XLAT,XLON,XE,YE,ZE,IDR)
000002      000      PI=3.14159265
000003      000      RDPDG=PI/180.0
000004      000      A=6378.15
000005      000      B=6356.77
000006      000      ESQ=(A-B)*(A+B)/A**2
000007      000      IF(IDR .EQ. 2)GO TO 10
000008      000      XLT=XLAT*RDPDG
000009      000      XLN=XLON*RDPDG
000010      000      CLT=COS(XLT)
000011      000      SLT=SIN(XLT)
000012      000      CLN=COS(XLN)
000013      000      SLN=SIN(XLN)
000014      000      RR=A/SQRT(1.-ESQ*SLT**2)
000015      000      XE=CLT*CLN*RR
000016      000      YE=CLT*SLN*RR
000017      000      ZE=SLT*RR*(1.-ESQ)
000018      000      RETURN
000019      000      10  CONTINUE
000020      000      IF(((XE**2+YE**2+ZE**2) .LT. B**2) .OR. ((XE**2+YE**2+ZE**2)
000021      000      * .GT. A**2))GO TO 15
000022      000      XLON=ATAN2(YE,XE)/RDPDG
000023      000      XLAT=ATAN(ZE/((1.-ESQ)*SQRT(XE**2+YE**2)))/RDPDG
000024      000      RETURN
000025      000      15  XLAT=100.
000026      000      XLON=200.
000027      000      RETURN
000028      000      ENDS
```

END ELT.

@HDC,P ***** ERTOST *****

***** EDGFT/MCIDAS *****

```
000113      000    706   FORMAT(2X,"DIMENSION=",I3)
000114      000          CALL TQ(MOUT)
000115      000          IX=IRES*(IRES-1)/2
000116      000          DO 470 I=1,IRES
000117      000          COEF(I)=WORK(I+IX)
000118      000          ENCODE(132,705,MOUT)I,COEF(I)
000119      000          CALL TQ(MOUT)
000120      000    470   ERCOEF(I,IPAIR)=COEF(I)
000121      000    490   CONTINUE
000122      000          TMN(IPAIR+1)=AMAX1(TMNL,TMNR)
000123      000          TMX(IPAIR+1)=AMIN1(TMXL,TMXR)
000124      000    500   CONTINUE
000125      000          CALL WCOM
000126      000          CALL EMESS(3HFIN,0)
000127      000          RETURN
000128      000    990   CONTINUE
000129      000          CALL TQ(72H ERROR RETURN FROM APCH, APFS.
000130      000          *
000131      000          RETURN
000132      000          ENDS
000133      000    $FILEMA
000134      000    DELETE GCCGCC,GORP
000135      000    $INCLUDE ATSSSP
000136      000    $CATALOG
000137      000    NAME=GCCGCC,5,R,W,D
000138      000    TYPE=FG
000139      000    LIB=ATSFLB,LL
000140      000    BEGIN
000141      000    $EOJ
```

END ELT.

@HDG,P ***** ERTOER *****

ORIGINAL PAGE IS
OF POOR QUALITY

***** EDGFT/MCIDAS *****

```
000056      000      ISCNL(NL)=1200-(IY1-1)/2
000057      000      IUL(NL)=JWIN(9,JVEC)*(T2-T1)/60.0
000058      000      GO TO 100
000059      000      200      CONTINUE
000060      000      NR=NR+1
000061      000      IF(NR.GT.300) GO TO 100
000062      000      ISCNR(NR)=1200-(IY1-1)/2
000063      000      IUR(NR)=JWIN(9,JVEC)*(T2-T1)/60.0
000064      000      GO TO 100
000065      000      400      CONTINUE
000066      000      IF(NL.LT.IP+1) GO TO 459
000067      000      DO 410 I=1,NL
000068      000      TS=PTIM(IPAIR+1)+ISCNL(I)*TMPSCL
000069      000      TMNL=AMIN1(TMNL,TS)
000070      000      TMXL=AMAX1(TMXL,TS)
000071      000      DATI(I)=ISCNL(I)
000072      000      410      DATI(I+NL)=IUL(I)/100.0
000073      000      DATI(2*NL+1)=-1.0
000074      000      CALL APCH(DATI,NL,IP,XD,XD,WORK,IER)
000075      000      IF(IER.LT.0) GO TO 990
000076      000      SCLLO(IPAIR)=XO
000077      000      SCLR1(IPAIR)=XD
000078      000      EPS=1.0E-4
000079      000      IOP=+1
000080      000      ETA=1.0E-3
000081      000      CALL APFS(WORK,IP,IRES,IOP,EPS,ETA,IER)
000082      000      IF(IER.LT.0) GO TO 990
000083      000      NLCOEFF(IPAIR)=IRES
000084      000      ENCODE(132,706,MOUT)IRES
000085      000      CALL TG(MOUT)
000086      000      IX=IRES*(IRES-1)/2
000087      000      DO 420 I=1,IRES
000088      000      COEF(I)=WORK(I+IX)
000089      000      ENCODE(132,705,MOUT)I,COEF(I)
000090      000      705      FORMAT(2X,'COEF(',I2,')=',E20.9)
000091      000      CALL TG(MOUT)
000092      000      420      ELCOEFF(I,IPAIR)=COEF(I)
000093      000      459      CONTINUE
000094      000      IF(NR.LT.IP+1) GO TO 490
000095      000      DO 460 I=1,NR
000096      000      TS=PTIM(IPAIR+1)+ISCNR(I)*TMPSCL
000097      000      TMNR=AMIN1(TMNR,TS)
000098      000      TMXR=AMAX1(TMXR,TS)
000099      000      DATI(I)=ISCNR(I)
000100      000      460      DATI(I+NR)=IUR(I)/100.0
000101      000      DATI(2*NR+1)=-1.0
000102      000      CALL APCH(DATI,NR,IP,XD,XD,WORK,IER)
000103      000      IF(IER.LT.0) GO TO 990
000104      000      SCLRO(IPAIR)=XO
000105      000      SCLR1(IPAIR)=XD
000106      000      EPS=1.0E-4
000107      000      IOP=+1
000108      000      ETA=1.0E-3
000109      000      CALL APFS(WORK,IP,IRES,IOP,EPS,ETA,IER)
000110      000      IF(IER.LT.0) GO TO 990
000111      000      NRCOEFF(IPAIR)=IRES
000112      000      ENCODE(132,706,MOUT)IRES
```

***** EDGFT/MCIDAS *****

@ELT,L AF,EDGFT/MCIDAS

ELT007 RLIB62 12/22-17:01:44-(0,)

```
000001 000 SJOB EDGFIT U3200
000002 000 SOPTION .8,9,13,20
000003 000 SFORTRAN
000004 000 SUBROUTINE MAIN
000005 000 DIMENSION JWIN(11,10)
000006 000 DIMENSION DATI(601),WORK(231),COEF(21)
000007 000 DIMENSION ISCNL(300),ISCNR(300),IUL(300),IUR(300),NOUT(17)
000008 000 DIMENSION MIN(10)
000009 000 DIMENSION MOUT(44)
000010 000 COMMON/NAVCOM/NAVN,INAV,IYR,IDAY,TOTLIN,DEGLIN,TOTIEL,DEGELE,PICLI
000011 000 *N,PICELE,TMPSC,IOYR,IODAY,TM,R1X,R1Y,R1Z,R1DX,R1DY,R1DZ,PITCH,ROL
000012 000 *L,YAW,PTIM(3),TMN(3),TMX(3),NLCOEF(2),NRCOEF(2),SCLLD(2),SCLL1(2),
000013 000 *ELCOEF(11,2),SCLR0(2),SCLR1(2),ERCOEF(11,2),NASCEF,SCLAS0,SCLAS1,
000014 000 *IELEMN,IELEMX,ASCOEF(16)
000015 000 DATA TMNL/1440.0/,TMXL/0.0/,TMNR/1440.0/,TMXR/0.0/
000016 000 DATA LUN/10/,JSECSV/-1/,NUMPER/10/,NUMENT/11/,JOUT/2/
000017 000 DATA MIN/6HGCGGCC,8*0/
000018 000 CALL IQ(MIN)
000019 000 IP=11
000020 000 CALL RCOM
000021 000 ENCODE(132,701,MOUT)PTIH
000022 000 701 FORMAT(5X,3F20.6)
000023 000 CALL TP(1,MOUT)
000024 000 CALL VARASG('WIN',LUN)
000025 000 CALL OPN(LUN)
000026 000 DO 500 IPAIR=1,2
000027 000 NL=0
000028 000 NR=0
000029 000 TMNL=1440.0
000030 000 TMXL=0.0
000031 000 TMNR=1440.0
000032 000 TMXR=0.0
000033 000 CALL SCRA(LUN,0)
000034 000 IK=0
000035 000 90 CONTINUE
000036 000 100 CONTINUE
000037 000 JSEC=IK/NUMPER
000038 000 JVEC=MOD(IK,NUMPER)+1
000039 000 IF(JSEC.NE.JSECSV) CALL READW(LUN,110,JWIN)
000040 000 IF(JSEC.NE.JSECSV) JSECSV=JSEC
000041 000 IK=IK+1
000042 000 IF(JWIN(1,JVEC).EQ.0) GO TO 400
000043 000 IH=MOD(JWIN(4,JVEC),10)
000044 000 IF(IH.GT.4) GO TO 100
000045 000 T1=FTIME(JWIN(2,JVEC))
000046 000 T2=FTIME(JWIN(3,JVEC))
000047 000 IF(T1.NE.PTIM(1).OR.T2.NE.PTIM(IPAIR+1))GO TO 100
000048 000 IF(MOD(JWIN(4,JVEC)/100,1000).NE.100) GO TO 100
000049 000 IY1=JWIN(5,JVEC)
000050 000 IY2=JWIN(7,JVEC)
000051 000 IF(IY1.NE.IY2) GO TO 100
000052 000 IX1=JWIN(6,JVEC)
000053 000 IF(IX1.GE.PICELE) GO TO 200
000054 000 NL=NL+1
000055 000 IF(NL.GT.300) GO TO 100
```

ORIGINAL PAGE IS
OF POOR QUALITY

***** EDGCR/MCIDAS *****

@ELT,L AF.EDGCR/MCIDAS

ELT007 RLIB62 12/22-17:01:44-(0,)

```
000001 000      SUBROUTINE EDGCR(PTIME,ALIN,DELLIN,DELELE)
000002 000      COMMON/NAVCOM/NAVN,INAV,IYR,IDAY,TOTLIN,DEGLIN,TOTIEL,DEGELE,PICLI
000003 000      *N,PICELE,TMPSCL,IYR,IODAY,TM,R1X,R1Y,R1Z,R1DX,R1DY,R1DZ,PITCH,ROL
000004 000      *L,YAW,PTIM(3),TMN(3),TMX(3),NLCOEF(2),NRCOEF(2),SCLLO(2),SCLL1(2),
000005 000      *ELCOEF(11,2),SCLRO(2),SCLR1(2),ERCOEF(11,2),NASCEF,SCLAS0,SCLAS1,
000006 000      *IELEMN,IELEMX,ASCDEF(16)
000007 000      DATA A/522.07/,LC/1235/
000008 000      ISCAN=1200-(IFIX(ALIN-1))/2
000009 000      TIME=PTIME+ISCAN*TMPSCL
000010 000      DO 20 IC=2,3
000011 000      20  IF(TMN(IC).LE.TIME.AND.TIME.LE.TMX(IC)) GO TO 100
000012 000      DELLIN=0.0
000013 000      DELELE=0.0
000014 000      RETURN
000015 000      100  CONTINUE
000016 000      IX=IC-1
000017 000      XL=ISCAN*SCLL1(IX)+SCLLO(IX)
000018 000      CALL CNPS(EL,XL,ELCOEF(1,IX),NLCOEF(IX))
000019 000      XR=ISCAN*SCLR1(IX)+SCLRO(IX)
000020 000      CALL CNPS(ER,XR,ERCOEF(1,IX),NRCOEF(IX))
000021 000      DELELE=(EL+ER)/2.0
000022 000      MSC=1200-(LC-1)/2
000023 000      Y=ISCAN-MSC
000024 000      XX=SQRT(A**2-Y**2)
000025 000      DELTA=(ER-EL)/2.0
000026 000      RAD=Y**2-2*XX*DELTA-DELTA**2
000027 000      DELLIN=SQRT(RAD)-Y
000028 000      RETURN
000029 000      ENDS
```

END ELT.

@HDG,P ***** EDGFT/MCIDAS *****

***** EATOST/MCIDAS *****

```

@ELT,L AF.EATOST/MCIDAS
ELT007 RLIB62 12/22-17:01:43-(0,)
000001 000 SUBROUTINE EATOST(PICTIM,LNS,IES,LA,LO,IUNK,INAV,BETA,BETDOT,AF)
000002 000 PTIME=PICTIM
000003 000 IF(IUNK.EQ.1) GO TO 1
000004 000 IF(IUNK.EQ.2) GO TO 2
000005 000 RETURN
000006 000 1 CONTINUE
000007 -000 XLIN=LNS
000008 000 XELE=IES
000009 000 CALL SE(PTIME,XLIN,XELE,XLAT,XLON)
000010 000 LA=ILALO(XLAT)
000011 000 LO=ILALO(XLON)
000012 000 RETURN
000013 000 2 CONTINUE
000014 000 XLAT=FLALO(LA)
000015 000 XLON=FLALO(LO)
000016 000 CALL ES(PTIME,XLAT,XLON,XLIN,XELE)
000017 000 LNS=XLIN
000018 000 IES=XELE
000019 000 RETURN
000020 000 END

```

END ELT.
@HDG,P ***** EDGCOR/MCIDAS *****

ORIGINAL PAGE IS
OF POOR QUALITY

***** STTOLV/MCIDAS *****

@ELT,L AF.STTOLV/MCIDAS

ELT007 RLIB62 12/22-17:02:08-(G,)

```
000001 000 SUBROUTINE STTOLV (X,Y,Z,IDIR,TIME)
000002 000 C IF IDIR=1, POINTING VECTOR (X,Y,Z) IS TRANSFORMED
000003 000 C FROM SAT INERTIAL TO LOCAL VERTICAL FRAME.
000004 000 C IF IDIR=2, POINTING VECTOR (X,Y,Z) IS TRANSFORMED FROM
000005 000 C LOCAL VERTICAL TO SAT INERTIAL FRAME.
000006 000 CALL ORBIT(XS,YS,ZS,TIME)
000007 000 CALL NRMLIZ(XS,YS,ZS,XNORM)
000008 000 X1=X
000009 000 Y1=Y
000010 000 Z1=Z
000011 000 D=SQRT(XS**2+YS**2)
000012 000 IF (IDIR.EQ.2) GO TO 10
000013 000 X=(-YS*X1+XS*Y1)/D
000014 000 Y=(XS*ZS*X1+YS*ZS*Y1-Z1*D**2)/D
000015 000 Z=-(XS*X1+YS*Y1+ZS*Z1)
000016 000 RETURN
000017 000 10 X=-YS*X1/D+XS*ZS*Y1/D-XS*Z1
000018 000 Y=XS*X1/D+YS*ZS*Y1/D-YS*Z1
000019 000 Z=-D*Y1-ZS*Z1
000020 000 RETURN
000021 000 ENDS
```

END ELT.

@HDG,P ***** UNIT/MCIDAS *****

***** UNIT/MCIDAS *****

@ELT,L AF.UNIT/MCIDAS

ELT007 RLIB62 12/22-17:02:09-(0,)

```
000001      000      SUBROUTINE UNIT(A)
000002      000      C THIS ROUTINE RETURNS IN "A" A 3 X 3 IDENTITY MATRIX.
000003      000      C
000004      000      DIMENSION A(9),B(9)
000005      000      DATA B/1.0,0.0,0.0,
000006      000      *      0.0,1.0,0.0,
000007      000      *      0.0,0.0,1.0/
000008      000      DO 10 I=1,9
000009      000      10 A(I)=B(I)
000010      000      RETURN
000011      000      ENDS
```

END ELT.
@HDG,N
@FIN

ORIGINAL PAGE IS
OF POOR QUALITY