

General Disclaimer

One or more of the Following Statements may affect this Document

- This document has been reproduced from the best copy furnished by the organizational source. It is being released in the interest of making available as much information as possible.
- This document may contain data, which exceeds the sheet parameters. It was furnished in this condition by the organizational source and is the best copy available.
- This document may contain tone-on-tone or color graphs, charts and/or pictures, which have been reproduced in black and white.
- This document is paginated as submitted by the original source.
- Portions of this document are not fully legible due to the historical nature of some of the material. However, it is the best reproduction available from the original submission.

(NASA-CR-150625) COAL THICKNESS GAUGE USING
RRAS TECHNIQUES, PART 1 Final Report
(Southwest Research Inst.) 97 p
HC A05/MF A01

N78-20573

CSCI 08I

G3/43

Unclas
11886

COAL THICKNESS GAUGE USING RRAS TECHNIQUES

by

W. L. Rollwitz

J. Derwin King

FINAL REPORT - PART I

SwRI Project 15-4967

Contract No. NAS8-32606

for

**George C. Marshall Space Flight Center
Marshall Space Flight Center, Alabama 38512**

20 January 1978

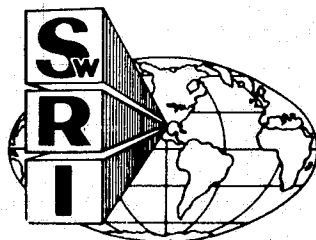

SOUTHWEST RESEARCH INSTITUTE
SAN ANTONIO CORPUS CHRISTI HOUSTON

SOUTHWEST RESEARCH INSTITUTE
Post Office Drawer 28510, 6220 Culebra Road
San Antonio, Texas 78284

COAL THICKNESS GAUGE USING RRAS TECHNIQUES

by
W. L. Rollwitz
J. Derwin King

FINAL REPORT - PART I
SwRI Project 15-4967
Contract No. NAS8-32606

for
George C. Marshall Space Flight Center
Marshall Space Flight Center, Alabama 38512

20 January 1978

Approved:

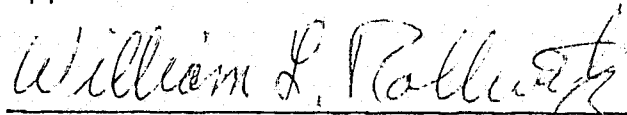

William L. Rollwitz, Principal Investigator

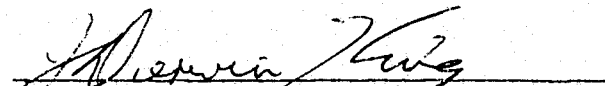

J. Derwin King, Project Manager

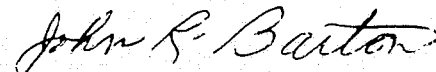

John R. Barton, Vice President
Instrumentation Research Division

TABLE OF CONTENTS

	<u>Page</u>
LIST OF ILLUSTRATIONS	iv
I. INTRODUCTION	1
A. The Problem	1
B. Background	2
C. Objectives	5
D. Results	5
II. PROGRAM METHODS	9
A. Phase A Tasks	10
1. Literature Search	10
2. Sample Supply	10
3. Sample Preparation	13
4. Electron Magnetic Resonance (EMR) Measurements on Samples	15
5. Assembly of Hydrogen NMR Equipment, and	20
6. Hydrogen Transient NMR Measurements	20
7. Data Analyses	23
B. Phase B Tasks	23
1. Mathematical Model	23
2. Analysis of Mathematical Model	24
3. Experimental EMR Laboratory Apparatus for Low Frequencies	25
4. EMR Measurements at Low Frequencies	25
5. Data Analysis and Conclusions	26
III. PROGRAM RESULTS	27
A. Results of Sample Studies	27
1. Coal-Rock Interfaces - First Series Samples	27
2. Coal-Rock Interfaces - Second Series Samples	35
3. Data Analyses	40

TABLE OF CONTENTS (Cont'd)

	<u>Page</u>
B. Results of Low Frequency Studies	43
1. EMR Equipment for 154.5 MHz	43
2. EMR Signals from Coal at 154.5 MHz	45
C. Results of Model Studies	50
1. Mathematical Model of the Detection Technique	50
2. Computer Analyses of Mathematical Model	57
IV. CONCLUSIONS AND RECOMMENDATIONS	73
A. Conclusions	73
B. Recommendations	76

APPENDIX A. Bibliography

LIST OF ILLUSTRATIONS

<u>Figure</u>	<u>Title</u>	<u>Page</u>
1	Diagram of Sample Positions at Drummond Strip Mine	12
2	Sample Positions in the Bruceon Mine	14
3	EMR Signals from Coal Near the First Interface	16
4	EMR Signals from Rock Near the First Interface	18
5	Electron Magnetic Resonance Signals from Coal (a) and Rock (b) Near Position 5 on Interface 1	19
6	Hydrogen Free Induction Decay Signals from Anthracite Coal	21
7	Hydrogen Free Induction Decay Signals from Forge Coal	22
8	EMR Signal Amplitude as a Function of Distance at Position No. 1, Interface No. 1	28
9	EMR Signal Amplitude as a Function of Distance at Position No. 5, Interface No. 1	30
10	EMR Signal Amplitude as a Function of Distance at Interface No. 2	31
11	EMR Signal Amplitude as a Function of Distance at Interface No. 3	34
12	EMR Signal Amplitude as a Function of Distance at Interface No. 3 (Revised Technique)	36
13	EMR Signal Amplitude as a Function of Distance at Interface No. 4	37
14	Mean Values and Limits of EMR Signal Amplitudes from the Bruceon Mine Samples	38
15	Distribution of the EMR Signals from the Drummond Strip Mine Rock Samples	41

LIST OF ILLUSTRATIONS (Cont'd)

<u>Figure</u>	<u>Title</u>	<u>Page</u>
16	Distribution of the EMR Signals from the Drummond Strip Mine Coal Samples	42
17	Block Diagram of the Experimental 154.5 MHz EMR Apparatus	44
18	Recording of the 155 MHz EMR Signal from Coal	46
19	Amplitude of the 155 MHz EMR Coal Signal as a Function of Modulation Level	48
20	Linewidth of the 155 MHz EMR Coal Signal as a Function of Modulation Level	49
21	Graphs of Four of the Equations Used in the Analytical Model	56
22	Constant Field Intensity Contours for Two-Pole Magnet with $W/S=4$	59
23	Constant Field Intensity Contours for Two-Pole Magnet Pole with $W/S=2$	61
24	Constant Intensity Contours with $\pm 5\%$ Limits for Two-Pole Magnet with $W/S=4$	62
25	Constant Intensity Contours with $\pm 5\%$ Limits for Two-Pole Magnet with $W/S=2$	63
26	The Constant Flux Density Surface for Two-Pole Magnet	64
27	Relative Amplitude EMR Signal as a Function of Electromagnet Current for Continuous Coal	66
28	Relative Amplitude EMR Signal as a Function of Current for a Coal-Rock Interface at 2 Inches	67
29	Graph Similar to Figures 27 and 28 But with the Coal-Rock Interface at 5 Inches	68

LIST OF ILLUSTRATIONS (Cont'd)

<u>Figure</u>	<u>Title</u>	<u>Page</u>
30	Graph Similar to Figures 27, 28, and 29 But with the Coal-Rock Interface at 9 Inches	69
31	Relative EMR Signal Amplitude as a Function of Distance for a Coal-Rock Interface at 5 Inches	70
32	Relative EMR Signal Amplitude as a Function of Distance for a Coal-Rock Interface at 10 Inches	72

I. INTRODUCTION

A. The Problem

For reasons of high productivity and maximum recovery of available natural resources, a goal of modern, mechanized coal mining is to cut as close to the coal-rock interface as is practical. However, for reasons of safety, health and product quality, it is also necessary to avoid cutting through the interface into the rock and it is desirable to leave a thin -continuous layer of coal of a selected thickness which may range from a fraction of an inch to as much as several inches. To achieve both of these goals, it is necessary to control the mining machinery to maintain the thickness of the coal layer remaining over the rock within selected bounds. To permit such control a sensor which will measure the distance from the cut surface of the coal to the coal-rock interface is needed. To be most suited for use in a coal-thickness gauge, such a sensor must be non-contacting, must have a measurement range of 0 to 6-in. or more, and an accuracy of 0.5-inch or better. In addition, variations in spacing of as much as several inches between the sensor and the cut surface should introduce no thickness measurement errors, the response speed should be adequate to permit use on continuous mining equipment, and the device should be sufficiently rugged and otherwise suited for mounting on or near a cutting head. The sensor as well as the associated electronics must be suitable for operation under conditions of high levels of vibration, moisture and dust. It is also necessary that the gauge characteristics be such that natural effects occurring in coal such as impurities, voids, cracks, layering, high

moisture level, and other conditions likely to be encountered do not introduce objectionable measurement errors.

This report covers the successful completion of the first two phases of the feasibility study based on using the radiofrequency resonance absorption (RRAS) techniques of electron magnetic resonance (EMR) and nuclear magnetic resonance (NMR) as the basis for a coal thickness gauge meeting the foregoing requirements. As a result of this study, the EMR technique has been found, from both analyses and experiments, to be particularly well suited for this application. Continued efforts in analysis, experimental evaluation and equipment development is indicated.

B. Background

In the past, many sensing techniques have been investigated for potential usefulness in coal thickness gauging. These have included penetrating radiation, electrical conductivity, dielectric constant, acoustic and electromagnetic wave methods. All of these methods have been found to have limitations when considered for the coal mining application. The limited measurement range, the requirement for contact between the coal and the sensor, the poor performance when measuring inhomogeneous, layered and lossy materials or some other objectional characteristics have prevented any of these methods being an entirely suitable basis for a practical coal thickness gauge.

On the basis of prior work at Southwest Research Institute with radio frequency resonance absorption methods, it was believed that at least one, EMR, and perhaps a second, NMR, of these techniques, offered the

potential of providing an ideal solution to the coal thickness gauging problem. This prior work, which had extended over a period of 25 years, has included the study of the NMR and EMR characteristics of many materials and the development of a wide variety of special instrumentation using these techniques for sensing measurement, and control applications. This prior work had included measurements of the EMR and NMR characteristics of several types of coal. It had also included the development of NMR apparatus for detecting explosives buried a few inches below the surface of the ground, the development of laboratory EMR apparatus capable of accommodating large samples and the development of laboratory apparatus which was capable of sensing the EMR response of coal and charcoal samples over separation distances of several inches. From this background it was known that many, if not all, types of coal exhibited a very strong EMR response characteristic. It was also known that this was unique and that few, if any, other naturally occurring materials produced similar levels of EMR response. From previous work it was also believed feasible to develop instrumentation that could make use of this characteristic to sense the presence of coal over separation distances of at least several inches and concepts for using this technique to provide a non-contacting means for measuring coal thickness were also formulated. On the basis of the previous work, it was also believed that the hydrogen nuclear magnetic resonance in coal could also possibly be useful but it was known that the magnitude of the NMR effect is several hundred times lower than that of the free electron magnetic resonance.

However, the use of interactions between the hydrogen nuclei and the free electrons was considered to be potentially advantageous should problems be encountered in the use of pure EMR.

The conclusion based on the prior experience at SwRI was that EMR, and perhaps NMR, methods could potentially be used in a non-contacting manner to detect the coal, the coal-air interface and the coal-rock interface and that this information could be used for determining the coal layer thickness. It was also concluded that such a thickness gauge should provide the following characteristics:

- . responsive directly and most strongly to coal
- . useful on all types of coal and rock
- . non-contacting
- . independent of interface reflections and layering
- . thickness measurement range of 6-in. (15 cm) or more
- . acceptable measurement accuracy
- . useful, size, weight and power consumption
- . basically suitable for use in mining environment
- . useful for both measurement and control

Factors which were not sufficiently well-known were primarily those relating to the NMR and EMR characteristics of a sufficiently wide variety of coals and rocks, particularly those in the interface region. In addition, further information on the detailed system requirements, the expected performance characteristics and the limitations was needed to

better define the suitability of the techniques for coal thickness gauging. The program of this report was proposed, approved and undertaken to provide information in these areas and others relating to the establishment of the basic feasibility of the RRAS methods for use in coal thickness gauging.

C. Objectives

The program was originally proposed in four phases. Only Phase A and Phase B, the feasibility phases, were initially authorized and this report is limited to those efforts.

The objectives of Phase A were to -

1. Determine the NMR and EMR characteristics of coal, interface and rock materials, and
2. analyze the NMR and EMR data to determine feasibility, system requirements, performance characteristics and limitations.

The objectives of Phase B were to -

1. Design and assemble a laboratory experimental model of the system indicated by the results of Phase A,
2. and obtain experimental evidence for the basic feasibility and characteristics for the technique indicated for measuring coal thickness.

D. Results

Work conducted under the initial phases of Contract NAS8-32606 has included extensive laboratory measurements of the EMR response characteristics of coal and rock samples taken from locations near and

across a number of interface regions, an evaluation of the technique based on an analytical model of a thickness gauging concept, the assembly of laboratory apparatus to further evaluate the concept and to verify analytical results and a limited investigation of the NMR characteristics of coal and rock samples. All results confirm the basic feasibility of using EMR as the basis for development of a practical coal thickness gauge.

The findings of laboratory EMR investigation of coal and rock samples indicate that the coal-rock interface, as well as the coal-air interface, is readily discernible on the basis of the large difference in the amplitude of the EMR characteristics of coal compared to that of either air or rock. Positive results in these characteristics confirms the existence of a measurable EMR effect that should be useful in defining the thickness of the layer of coal overlying a rock substrate.

To further establish the suitability of the EMR technique for coal thickness gauging, the analytical study was conducted. This analysis was based on the findings of the foregoing sample studies and a conceptual model of a low-frequency EMR system which was considered to be basically suitable for use in the coal thickness gauging. This study provided information on: (1) the effects of selected system design parameters on the detection range and other characteristics; (2) the attainable resolution in defining the location of the front (coal-air) interface as well as the back (coal-rock) interface and (3) the detection sensitivity. The results of this analysis indicate the excellent probability of achieving a coal thickness measurement

resolution on the order of 1-cm or less, a thickness measurement range of 15-cm or more, and non-contacting operation. The study also indicates that the detection head required for such results to be of acceptable size, weight, and power requirements and to be basically suited for use in the mining environment.

To further verify the basic suitability of the EMR technique to coal thickness measurement, experimental laboratory apparatus was assembled and used to confirm important characteristics of the analytical model. This apparatus has shown the feasibility of detecting ESR in coal samples at the low magnetic field intensity (and corresponding low resonant frequency) ranges assumed in the analytical model. Tests were conducted with the apparatus to determine the available sensitivity and the resonant line widths at magnetic field intensities of 57 gauss and 142 gauss, corresponding to those in the analytical models and in coal samples located a short distance outside the physical extent of the detection coil.

While the results to date have demonstrated the basic feasibility of the EMR method, further work is required to develop a model of the ESR coal thickness gauge which is suited for demonstration and evaluation of measurement range, gauging accuracy, speed and other characteristics. The analytical model study needs to be continued and used as a basis for determining optimum system design parameters and to further evaluate the influence of operational conditions on the speed, range, and accuracy of the thickness measurements. The effects of spacing between the detection head

and the front surface of the coal, the effects of vibration, and the effects of varying attenuation of the radiofrequency waves and ESR signals in the coal need to be evaluated. An experimental model of the coal thickness gauge then needs to be developed for further evaluation of the EMR technique under laboratory conditions and later, in a mine where tests may be conducted under controlled conditions. Provided success is achieved in these tests, the development of a system suitable for use in a mining environment then should be undertaken. The results in the preliminary investigation warrant the further development of the EMR technique for this purpose.

ORIGINAL PAGE IS
OF POOR QUALITY

II. PROGRAM METHODS

A program was undertaken to meet the objectives of Phase A and Phase B. Several tasks were performed in each phase. These tasks are:

Phase A Tasks

1. Perform literature search.
2. Obtain samples of coal, interface and rock materials.
3. Prepare samples for measurements.
4. Perform electron magnetic resonance measurements with the Varian Type EM500 Spectrometer at 10 GHz.
5. Assemble equipment for hydrogen transient NMR measurements.
6. Perform hydrogen transient NMR measurements with assembled equipment.
7. Analyze data, draw graphs, and calculate averages.

Phase B Tasks

1. Derive analytical or mathematical model.
2. Analyze analytical model and calculate results.
3. Construct and assemble experimental laboratory apparatus to obtain experimental data at 154.5 MHz.
4. Perform EMR measurements at 154.5 MHz on coal.
5. Analyze results and make conclusions.

The methods, procedures and techniques used to perform the Phase A and Phase B tasks will be discussed in the following sections.

A. Phase A Tasks

1. Literature Search

For the literature search, the library facilities at Southwest Research Institute were used. Copies of pertinent literature were obtained, studied and evaluated. The search areas that were used were: (1) magnetic resonance measurements on coal, interface and rock (slate, shale, limestone) materials; (2) steady-state and transient magnetic resonance techniques which are applicable to coal thickness measurements; and (3) interaction effects between nuclei and free electrons which may be used to enhance the interface detection. A bibliography is included as Appendix A.

2. Sample Supply

At the planning meeting to define program details, it was agreed that core or equivalent samples from across several interfaces would be needed to permit measurements of the concentrations of free electrons in samples taken at closely spaced intervals across the coal-rock interface. Cores from a number of different mining situations and locations were considered desirable to allow a better insight into the range of variations in electron magnetic resonance signals to be encountered. After sample sizes and amounts were discussed, the NASA program personnel agreed to obtain and to supply the required samples.

Two series of samples were supplied by NASA. None were taken from cores, but the care and expertise given to their selection gave useful results.

ORIGINAL PAGE IS
OF POOR QUALITY

The first series of coal and rock samples was taken from a strip mine owned by the Drummond Company, Bagley Division and located near the Bagley Bend of the Locust Fork Branch of the Warrior River. The cut had been exposed for about 10 days. Figure 1 is a representative diagram of the cut showing the relative positions of the coal-rock interfaces and the positions from which samples were taken.

Five series of samples were taken along lines perpendicular to the four interfaces. Two sets of samples were taken from two different positions around interface #1, while one set was taken from each of the other three interfaces: #2, #3, #4. The relative positions of each of the five sets of samples are shown in Figure 1. The samples were taken mostly at one-inch intervals, except close to the interface where one-half inch intervals were sometimes used. None of the samples were from the exact interfaces since the samples usually were at least one-half inch long and the interfaces were much narrower than that.

The first set of samples was taken around position 1 on the first interface and consisted of 22 samples taken along a line extending from 10.5 inches into the coal to 12 inches into the rock. A total of 22 samples were also taken around position 2 on the second interface from 12 inches into the coal to 8 inches into the rock. Around position 3 on the third interface, a total of 26 samples were taken from 12 inches into the coal to 12 inches into the rock. On the fourth or lowest interface at position 4, only 11 samples were obtained, because of the thinness of the seams, from

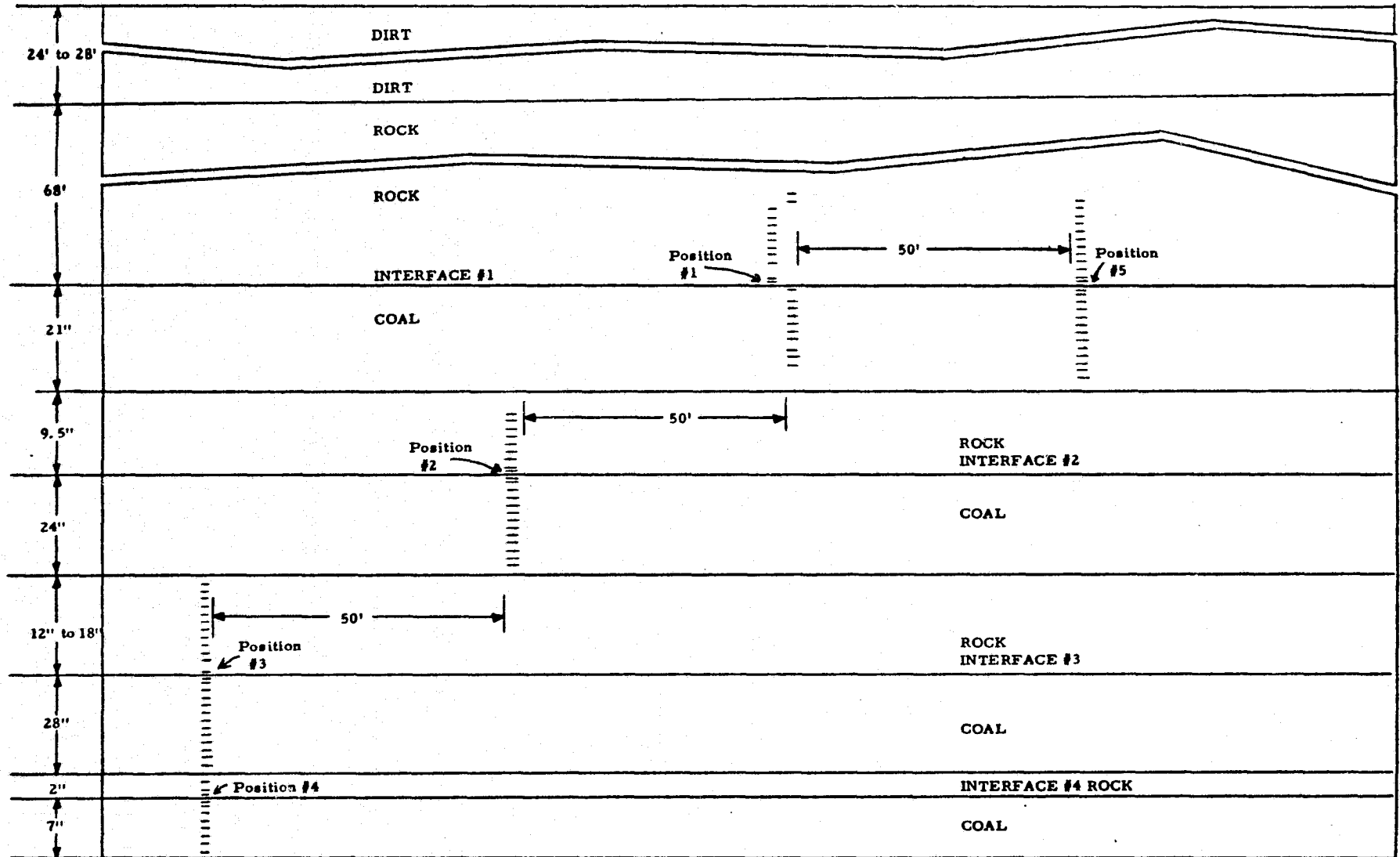

ORIGINAL PAGE IS
OF POOR QUALITY

FIGURE 1. DIAGRAM OF THE FIVE POSITIONS AT WHICH SAMPLES WERE TAKEN ON A CUT OF THE STRIP MINE OWNED BY THE DRUMMOND COMPANY, BAGLEY DIVISION, LOCATED IN JEFFERSON COUNTY NEAR THE BAGLEY BEND OF THE LOCUST FORK BRANCH OF THE WARRIER RIVER. The short lines at the five positions around the four interfaces are the places where the samples were taken.

2 inches into the rock to 7 inches into the coal. A fifth set of 24 samples was taken at position 5, the second place on the top or first interface, from locations extending from 11 inches into the rock to 12 inches into the coal.

A total of 105 samples were received in the first series. Most of the samples were small in size and meant to represent a half-inch length at locations along a line perpendicular to the interface at the different positions.

The second series of samples was composed of seven rather large-sized coal and rock samples from the Bruceeton, Pa., mine of the Bureau of Mines. These seven samples were taken from locations near a coal/rock interface and a rock/wild-coal interface. The relative positions from which each of the samples was taken are shown in the drawing of the three veins and the two interfaces given in Figure 2.

3. Sample Preparation

The coal and rock samples had to be held in or by something that would permit their insertion into the Varian Type EM-500 EMR Spectrometer. The recommended sample tubes for the EM-500 are 4 millimeters OD, 3 millimeters ID and 250 millimeters long. The decision was made to use these tubes because they were of uniform volume. This decision dictated that, for the greatest signal/noise ratio, the samples be ground to a fine powder. The reduction to powder form was accomplished by placing each sample, or a chosen part of each sample, into a ceramic ball mill driven by an electromechanical shaker. After a few minutes, each sample was reduced to a power fine enough to permit its insertion into the 3 millimeter ID sample tubes.

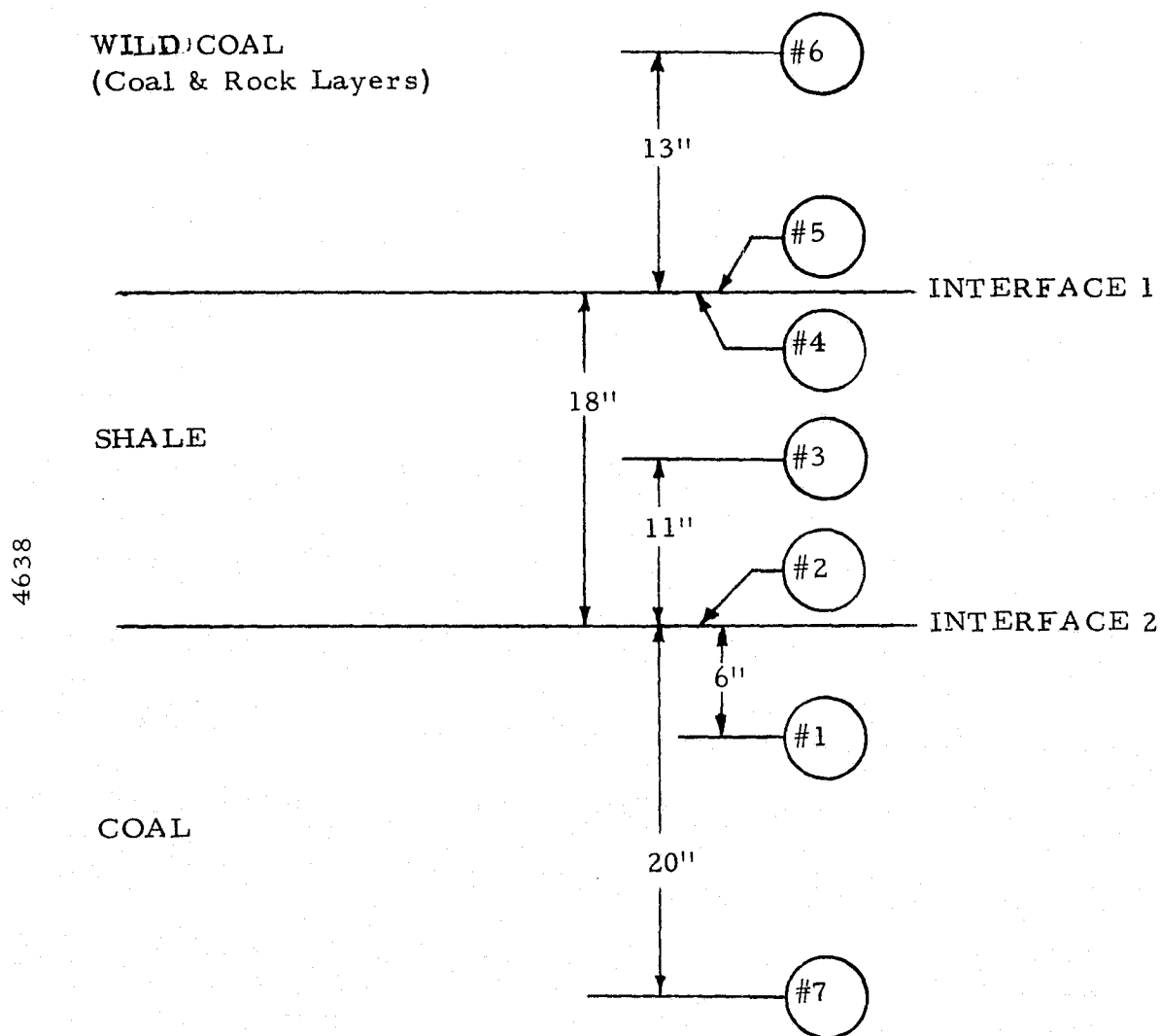

FIGURE 2. DRAWING OF THE WILD-COAL, SHALE AND COAL VEINS IN THE BRUCETON MINE SHOWING THE POSITIONS FROM WHICH THE SEVEN SAMPLES WERE TAKEN. The coal vein is 70 inches thick.

The first series of samples was each smaller in size than the second series, but adequate quantities of most of the first series samples were available to fill each tube above the sensitive length of the EM-500 Spectrometer, which was only slightly less than one inch. However, a few of the first series samples were smaller in quantity and filled the sample tube to a height less than one inch. For these samples, filling-factor corrections had to be made on the measured data. Even with the samples in the first series of smallest quantity, useful data were obtained.

From the second series, four small pieces were taken from each of the seven large samples to make four replicates. The small samples were chosen from places to be representative of the different colors, grey through black, of the constituents of the samples. These 28 pieces were then ground as previously described and inserted into sample tubes.

4. Electron Magnetic Resonance (EMR) Measurements on Samples

After the samples were ground and inserted into tubes, they were placed in the Varian Type EM-500 EMR Spectrometer and the derivatives* of the absorption spectra of the free electrons in the samples were recorded. Representative recorded signals from four of the coal samples, around position #1 of the first series, are reproduced in Figure 3. Representative recorded signals from four of the rock samples, taken from

*The description of how the derivative of the absorption is obtained is given very clearly in the book: "Electron Spin Resonance," by Charles P. Poole, Jr., Interscience Publishers Div. of John Wiley and Sons, 1967, Chapter 10.

4509

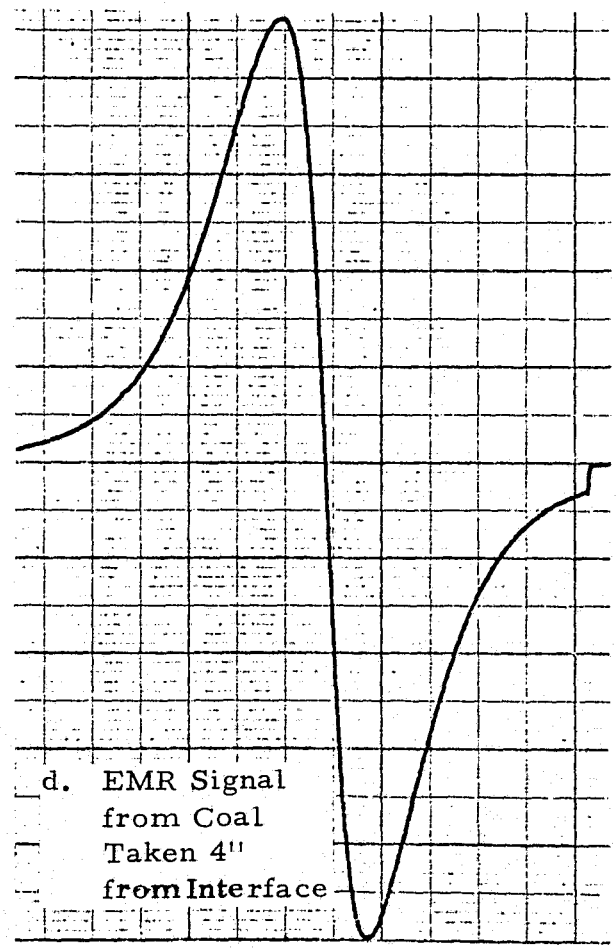
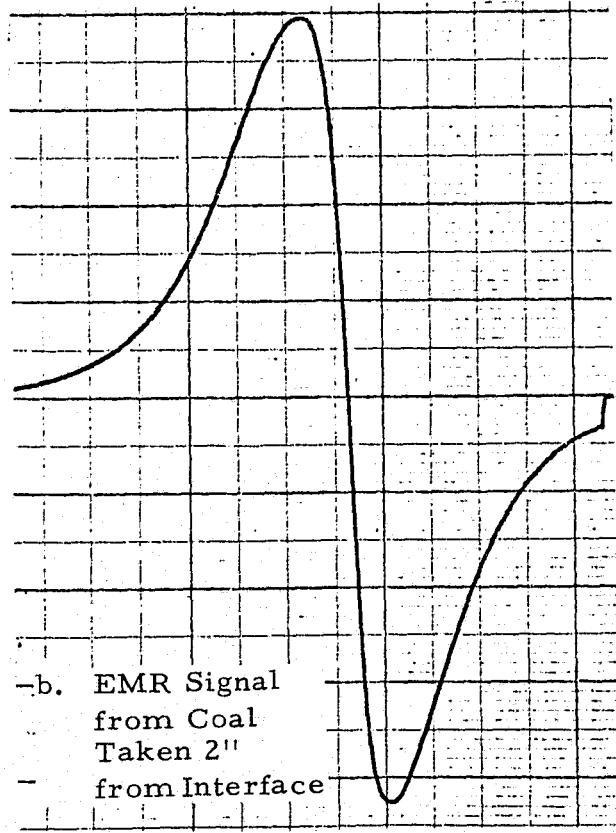
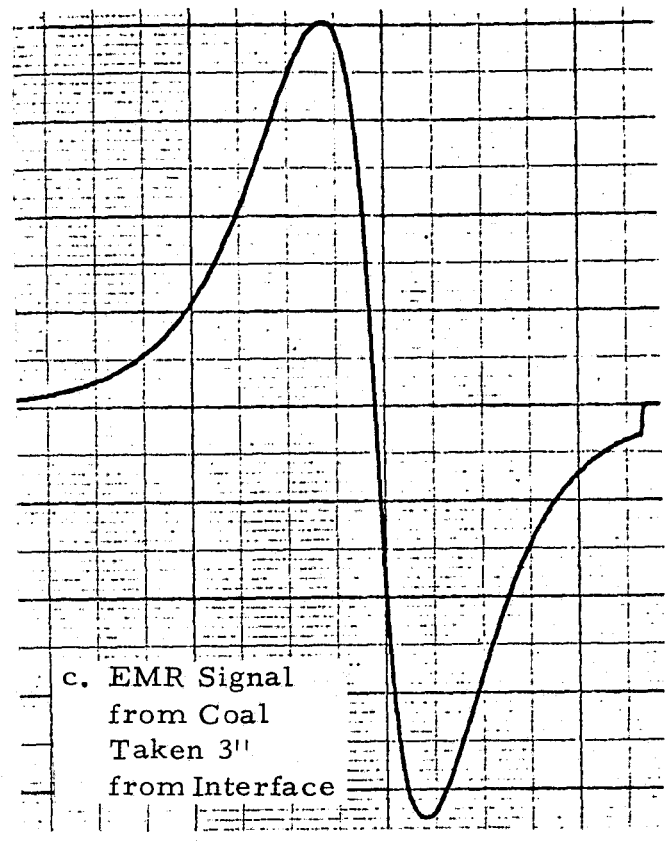
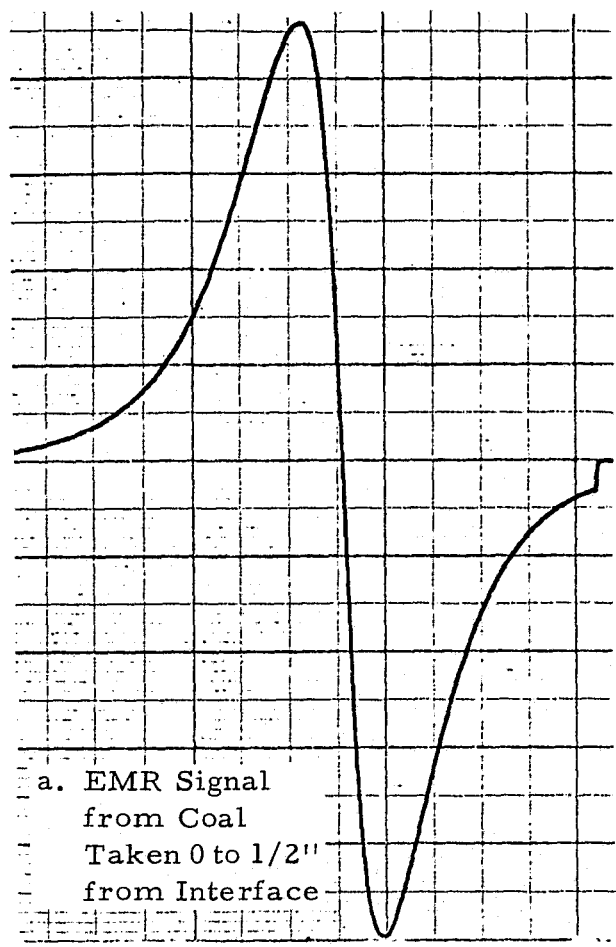
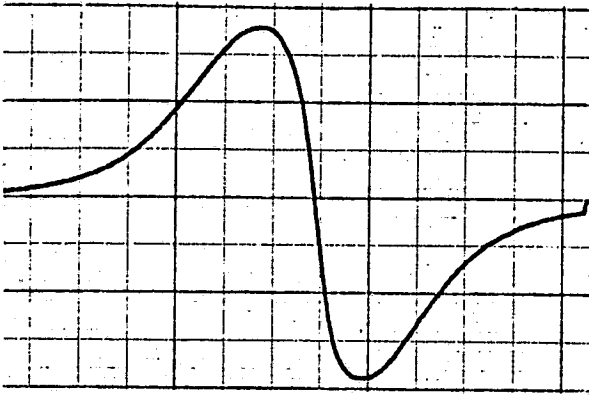

FIGURE 3. EMR SIGNALS FROM COAL AROUND THE FIRST (top) INTER-
FACE AT DISTANCES FROM THE INTERFACE OF (a) 0 to 1/2",
(b) 2", (c) 3" AND (d) 4".

around position #1 of the first series, are reproduced in Figure 4. To compare the signals from the different samples, it is usually necessary to compare the products of the peak-to-peak amplitude and the width or the distance between the peaks in the recording direction for each recording. It was found after the signals from all of the first series of samples were recorded, that the width did not vary from sample to sample. Therefore, to compare samples it was only necessary to compare peak-to-peak amplitudes.

The recorded signals, from the rock around position #5 of the first series, had shapes different from those of the other coal and rock samples. The difference is demonstrated by the signal comparison in Figure 5. The signal from the rock around position 5 (Figure 5b) is not symmetrical like the ones from the coal at position 5, the coal at all four other positions and the rock at all four other positions -- all of which are represented by the signal in Figure 5a. The slight double peak on one side of the recorded signal in Figure 5b indicates that there is a second source for electron magnetic resonance signals in all of the rock samples around position 5 and the resulting signal is displaced slightly in frequency from the one being produced by the main source of free electrons in the rock and coal at all of the other positions. The second source of free electron signals is unknown. No mention of this phenomenon was found in the literature and no chemical analysis was attempted to determine the source. Its presence should not interfere with the use of signals such as in Figure 5b for the determination of coal thickness.



a. EMR Signal from Rock Taken
0 to 1/2" from Interface

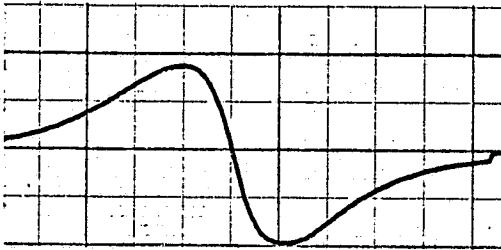

b. EMR Signal from Rock Taken
1" from Interface

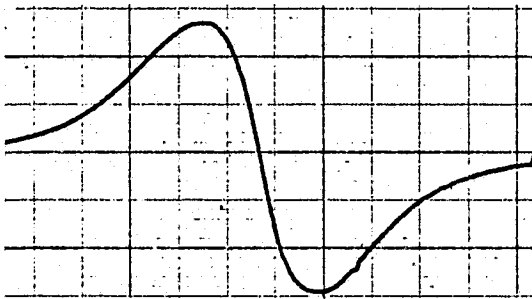

c. EMR Signal from Rock Taken
3" from Interface

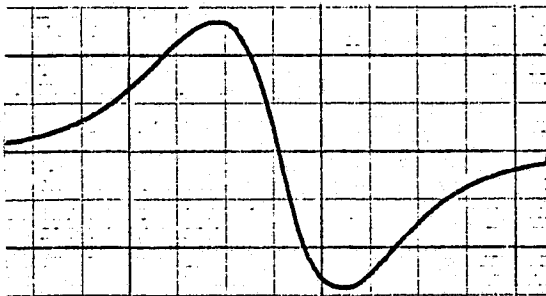

d. EMR Signal from Rock Taken
4" from Interface

4510

ORIGINAL PAGE IS
OF POOR QUALITY

FIGURE 4. EMR SIGNALS FROM ROCK AROUND THE FIRST (top) INTER-
FACE AT DISTANCES FROM THE INTERFACE OF (a) 0 to 1/2",
(b) 1", (c) 3", AND (d) 4".

4580

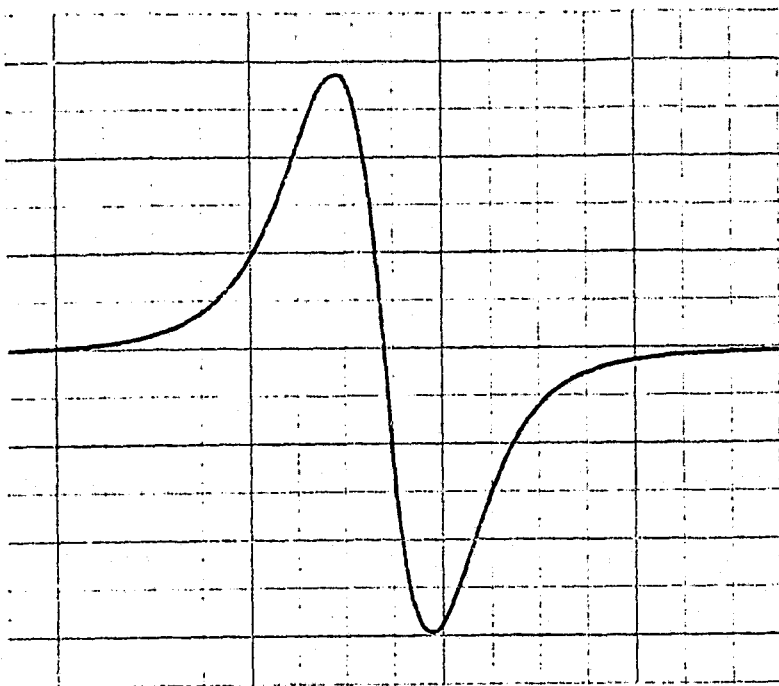

a. Recorded EMR
Signal from Coal
at Position 5

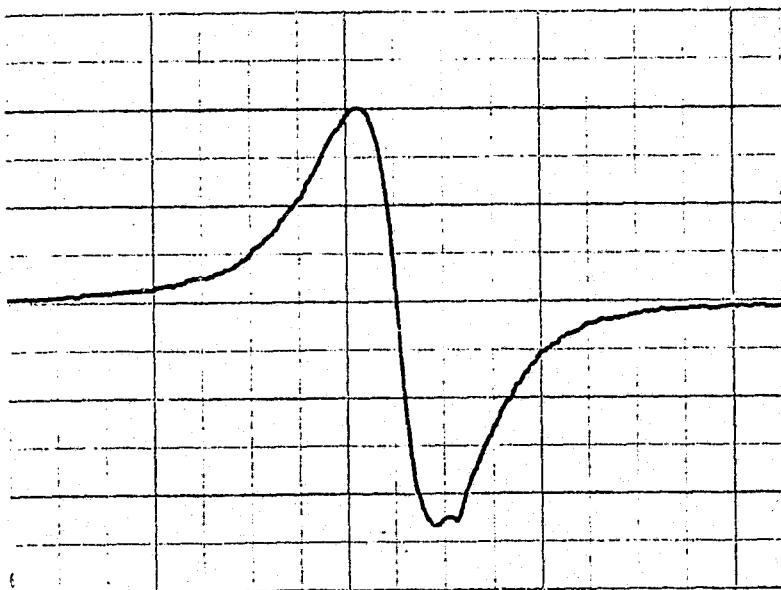

b. Recorded EMR
Signal from Rock
at Position 5

FIGURE 5. COMPARISON OF THE SHAPES OF THE ELECTRON MAGNETIC RESONANCE SIGNALS FROM COAL (a) AND ROCK (b) AROUND POSITION 5 ON INTERFACE 1 OF THE FIRST SUPPLY OF SAMPLES

5. Assembly of Hydrogen NMR Equipment, and
6. Hydrogen Transient NMR Measurements

The first and second series of samples were dry when received and contained little moisture. Therefore, it was believed not in the best interests of the project to perform transient hydrogen NMR measurements on all of the 133 samples on which EMR measurements were made. A few exploratory NMR signals were made at a frequency of 30 MHz which is 10 times higher than the 3.0 MHz projected for use if hydrogen NMR signals were adaptable to coal thickness measurements. The hydrogen transient NMR signals from two representative coal samples, in dry and artificially wet conditions, are given in Figures 6 and 7. All signals in Figures 6 and 7 are free induction decay types which means that they are the Fourier transform in the time domain of the resonance absorption curve in the frequency or magnetic field domain. These decay curves indicate that the hydrogen is in molecules which are bound in the coal in ways which give two and sometimes three relatively stable binding states. The signals from shale should be smaller in magnitude, but have similar shapes and numbers of components. Since the hydrogen transient NMR signals from coal and rock at 3 MHz would be at least two orders of magnitude lower than those in Figures 6 and 7 at 30 MHz, it was concluded that effort would be better spent on more potentially fruitful work than on the hydrogen transient NMR measurements of 133 samples of coal and rock.

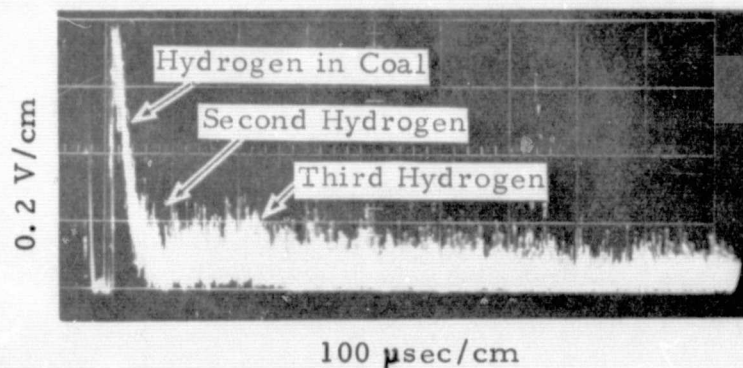

a. Total hydrogen free induction decay signal from ground anthracite showing three components.

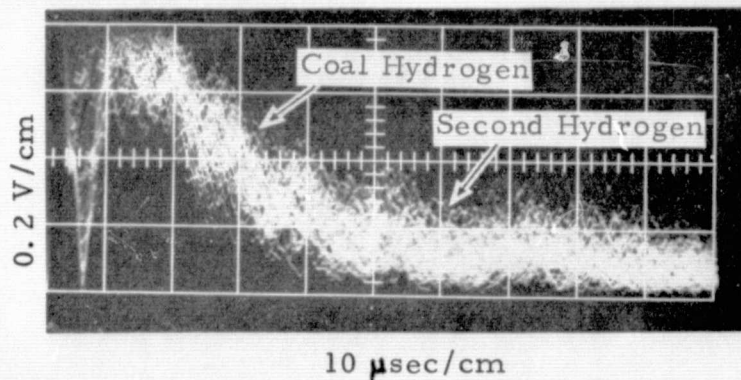

b. The signal in (a) expanded to show the first 100 microseconds.

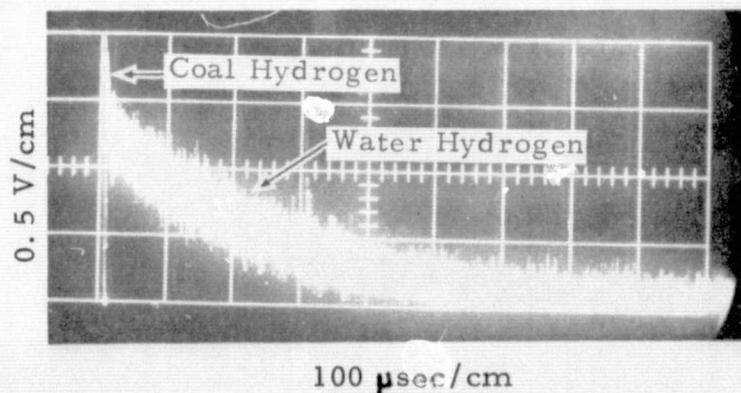

c. Total hydrogen free induction decay signal from anthracite coal with water added to form a slurry.

FIGURE 6. HYDROGEN FREE INDUCTION DECAY SIGNALS FROM GROUND ANTHRACITE COAL (a); WITH EXPANDED (10 times) HORIZONTAL SCALE (b); WITH WATER ADDED (c).

ORIGINAL PAGE IS
OF POOR QUALITY

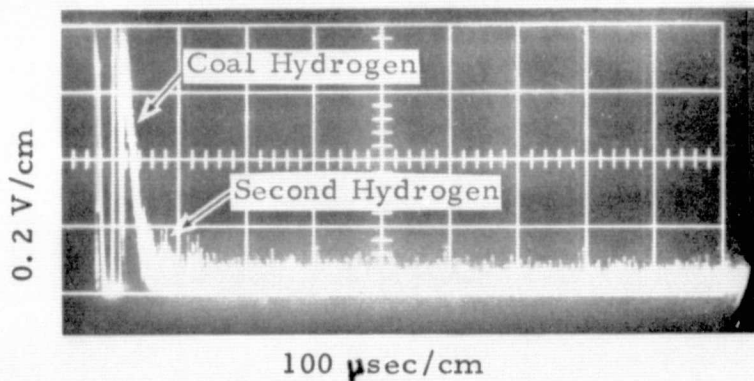

a. Total hydrogen free induction decay signal from ground Forge coal showing two components.

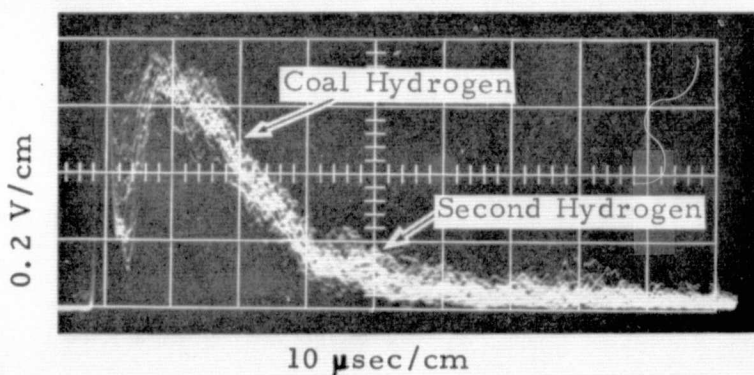

b. The signal in (a) expanded to show the first 100 microseconds.

ORIGINAL PAGE IS
OF POOR QUALITY

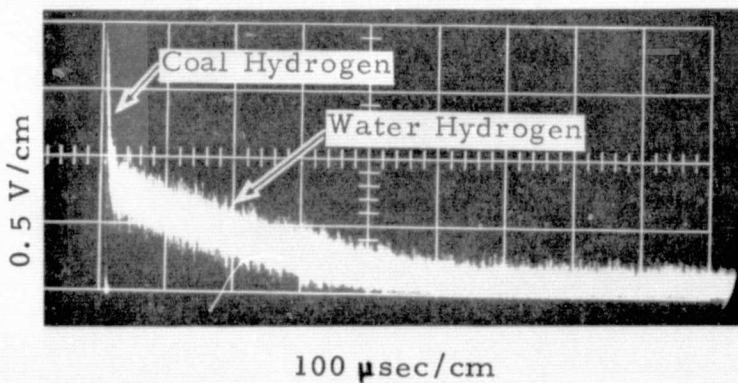

c. The total hydrogen free induction decay signal from ground Forge coal with water added to make a slurry.

FIGURE 7. HYDROGEN FREE INDUCTION DECAY SIGNALS FROM GROUND FORGE COAL (a); WITH EXPANDED (10 times) HORIZONTAL SCALE (b); WITH WATER ADDED (c).

7. Data Analyses

The electron magnetic resonance signals from the 133 samples of coal and rock were received as recordings of derivatives of the absorption curves. Figure 3 contains four representative recordings of the derivative signals from coal and Figure 4 has four typical records from rock. The peak-to-peak values of the derivative curves were first measured in terms of the calibrations on the recording paper where full scale is 100 divisions (5 inches). Second, each of the peak-to-peak values was normalized for the differences in equipment parameters used so that all signal values were proportional only to free electron concentrations.

Graphs were then made of the normalized magnitudes of the signals from the samples as functions of the position of the samples relative to the coal-rock interfaces. Five graphs were made for the first series of samples, one for each of the five positions on the four interfaces (two on interface No. 1); only one graph was needed for the second series.

Statistical analyses were made using the data from the first series of samples because of overlapping in magnitudes. Only averages and extremes at each point were made from the second sample series data.

B. Phase B Tasks

1. Mathematical Model

A mathematical model was developed of one representation of the use of electron magnetic resonance signals from the free

electrons in coal and rock to determine the position of a coal-rock interface. This model was needed to demonstrate the theoretical feasibility of the method, to provide a basis for parameter selection for optimum operation, and to analyze the method's operational characteristics.

As a first step, the bias magnet was modelled as a collection of magnetic dipoles made up of pairs of north and south monopoles situated symmetrically on the faces of the bias magnet. The resultant field is the sum at all points of interest of the total assembly of dipoles.

The radiofrequency magnetic field was that from a simple current loop which was calculated directly using elliptic integrals. The signal strength was assumed to vary proportional to the equation for the radiofrequency field, and the equation for the angle between the radiofrequency and bias magnetic fields. The electron magnetic resonance signal was obtained by summing all of the effects of a distribution of magnetic moments simulating the distribution of free electrons in the coal and the rock.

2. Analysis of Mathematical Model

The equations for the model were programmed in FORTRAN on an HP2100 computer. The results were plotted using a Tektronix 4051 graphic computer. The resultant graphs were used to evaluate both the model and the system. Several cycles of programming, plotting and analyzing were needed before all of the variables were directly relatable and the results viable.

3. Experimental EMR Laboratory Apparatus for Low Frequencies

The instruments and apparatus, wherein available at Southwest Research Institute, were connected as an electron magnetic resonance spectrometer for low magnetic fields of 50 to 60 Gauss. Where apparatus was not available, it was constructed. The pieces which were constructed were mainly the detection coils and matching networks required to apply the radiofrequency power from the generator to the detection coil, to reject the direct coupling of radiofrequency power to the receiver and to feed the EMR signal picked up by the detection coil to the receiver. Several different assemblies and constructed pieces were needed before repeatable results were obtained.

4. EMR Measurements at Low Frequencies

The assembled spectrometer was used to determine the signal-to-noise ratio of coal at frequencies equivalent to electron magnetic resonance detection in magnetic fields of from 50 to 60 Gauss, or at frequencies from 140 MHz to 168 MHz. From the characteristics and parameters of the equipment used and the results obtained, estimates were made of the primary design factors:

- . detection technique
- . operating frequency
- . measurement range
- . measurement accuracies

- . RF requirements
- . magnet requirements
- . configuration
- . size, weight and power

5. Data Analysis and Conclusions

After all of the above tasks were performed, the data were analyzed and the indicated conclusions made. These will be used to re-evaluate the program proposed previously for Phases C and D, and to design new tasks for these phases if warranted.

III. PROGRAM RESULTS

The program described in Section II resulted in much data which has been condensed and will be summarized in the following paragraphs. The results are followed by the conclusions.

A. Results of Sample Studies

The results which will be presented are in the areas of: graphs of EMR signal levels across coal-rock interfaces, analyses of EMR signal levels from 133 coal and rock samples, description of the equipment used for obtaining 154.5 MHz EMR signals from coal, the measured EMR signals from coal at 154.5 MHz, mathematical model of EMR used to detect coal-rock interfaces, and computer results from the mathematical model.

1. Coal-Rock Interfaces - First Series Samples

The EMR signal data from the 22 samples taken around position 1 on interface 1 (see Figure 1 for location) was processed as described in the previous section, and graphed in Figure 8. The peak-to-peak value of each of the EMR signals is positioned at the distance each sample was taken from the first position on the first interface. The EMR signal from the sample taken one-half inch into the coal from the first interface had a peak-to-peak amplitude of 96 units; the EMR signal from the corresponding position in the rock was 37 units.

The average value of the 10 EMR signals from the coal side of interface 1 at position 1 is 85.3; the average value of the 12 from

4511

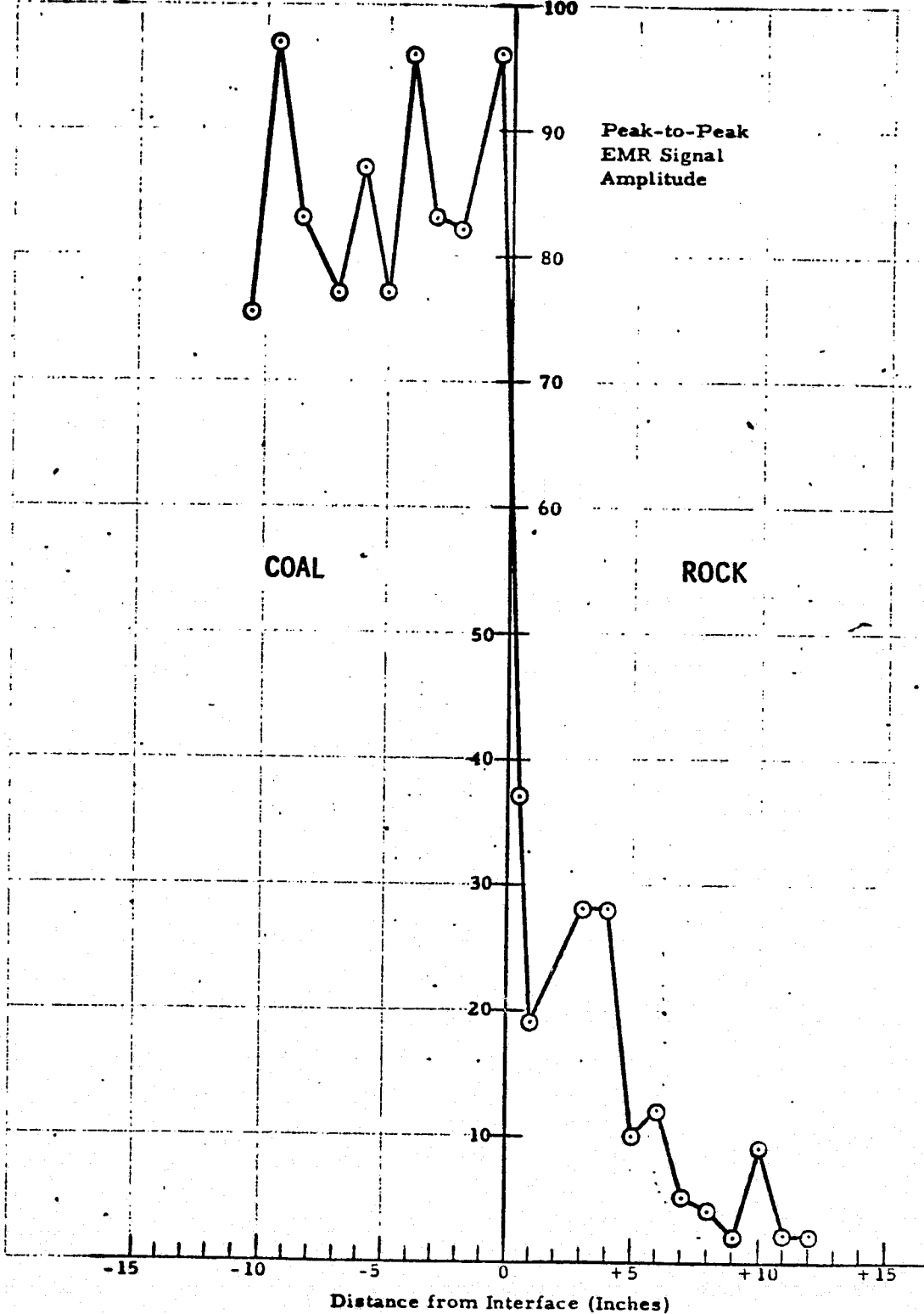

FIGURE 8. GRAPH OF THE PEAK-TO-PEAK VALUES OF THE RECORDED EMR SIGNALS FROM THE FIRST SERIES OF SAMPLES AS A FUNCTION OF DISTANCE FROM INTERFACE NO. 1 at POSITION NO. 1.

ORIGINAL PAGE IS OF POOR QUALITY

the rock side is 13.2. Therefore, on the average the EMR signal from the free electrons in the coal is 6.48 times the EMR signal from the rock around interface 1 at position 1.

At position No. 5, which is 50 feet to the right of position 1, the EMR signals around interface No. 1 gave the graph in Figure 9. While interface No. 1 at position 1 was well defined by the EMR signals, as shown by the graph in Figure 8, the same interface at a second position is even more well defined by the EMR signals as shown in Figure 9. The peak-to-peak signal at position 5, one-half inch into the coal from the first interface is 68 units, while the signal at the same distance into the rock is 4.5 units. Thus, the coal-to-rock signal ratio across the first interface at position 5 is 15 to 1 as compared to 2.6 to 1 at position 1.

The average value of the 12 EMR signals from the coal side of the first interface at position 5 is 69.1; the average value for the 12 from the rock side is 5.9. Therefore, on the average, the EMR signal from the free electrons in the coal is 11.7 times that from the rock around the first interface at position 5. By comparison, the factor was 6.48 around the first interface at position 1.

The graph of the data from interface 2 (position 2 in Figure 1) is given in Figure 10. The signal from one-half inch into the coal from interface 2 has an amplitude of 58 units, while the amplitude from a similar distance into the rock is 6 units. The ratio of EMR signals from coal-to-rock across the second interface is 9.67 to 1 which is in between

4579

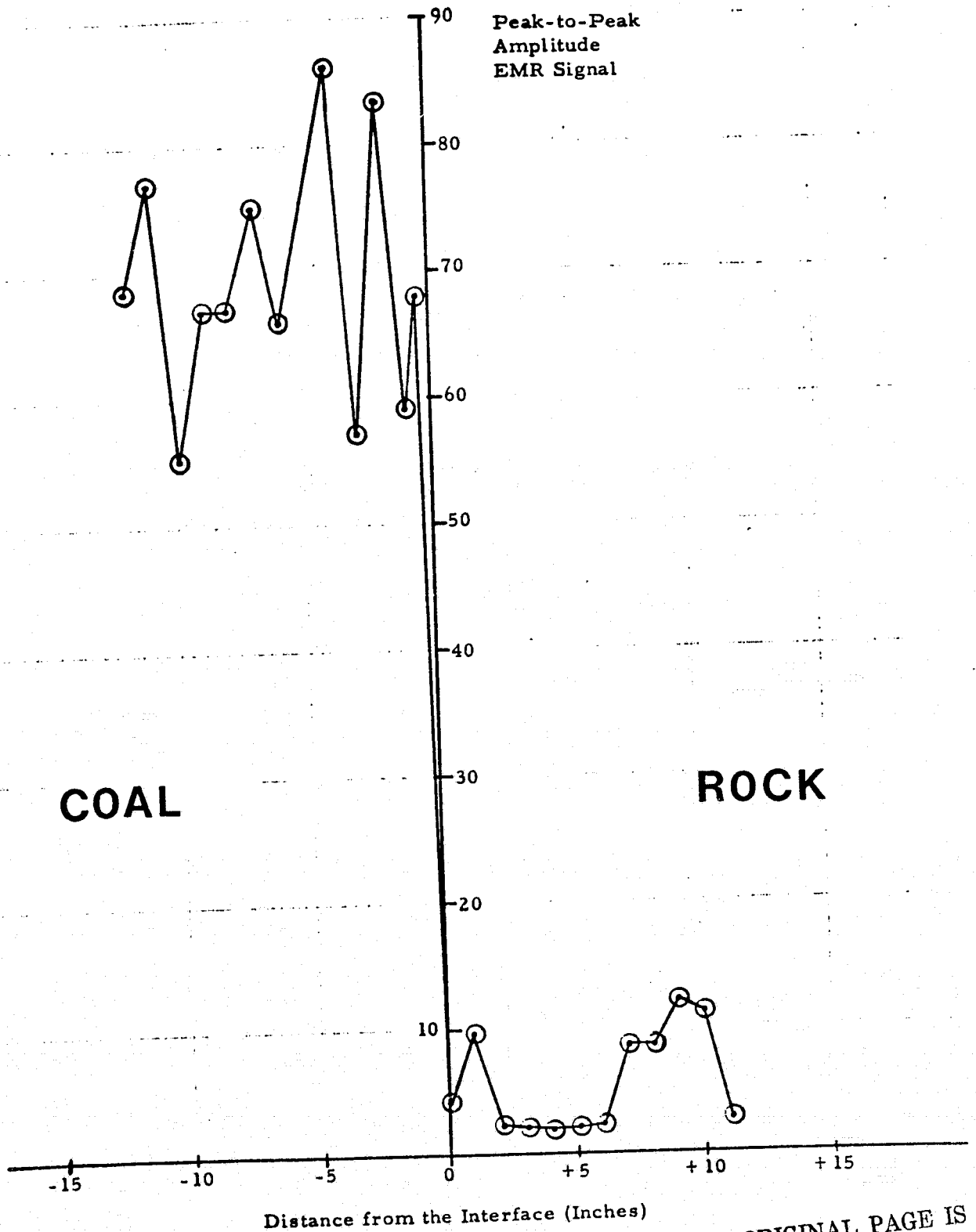

ORIGINAL PAGE IS
OF POOR QUALITY

FIGURE 9. GRAPH OF THE PEAK-TO-PEAK VALUES OF THE ELECTRON MAGNETIC RESONANCE SIGNALS FROM SAMPLES TAKEN AT VARIOUS DISTANCES AROUND THE FIRST INTERFACE (Position 5) OF THE FIRST SUPPLY OF SAMPLES

4576

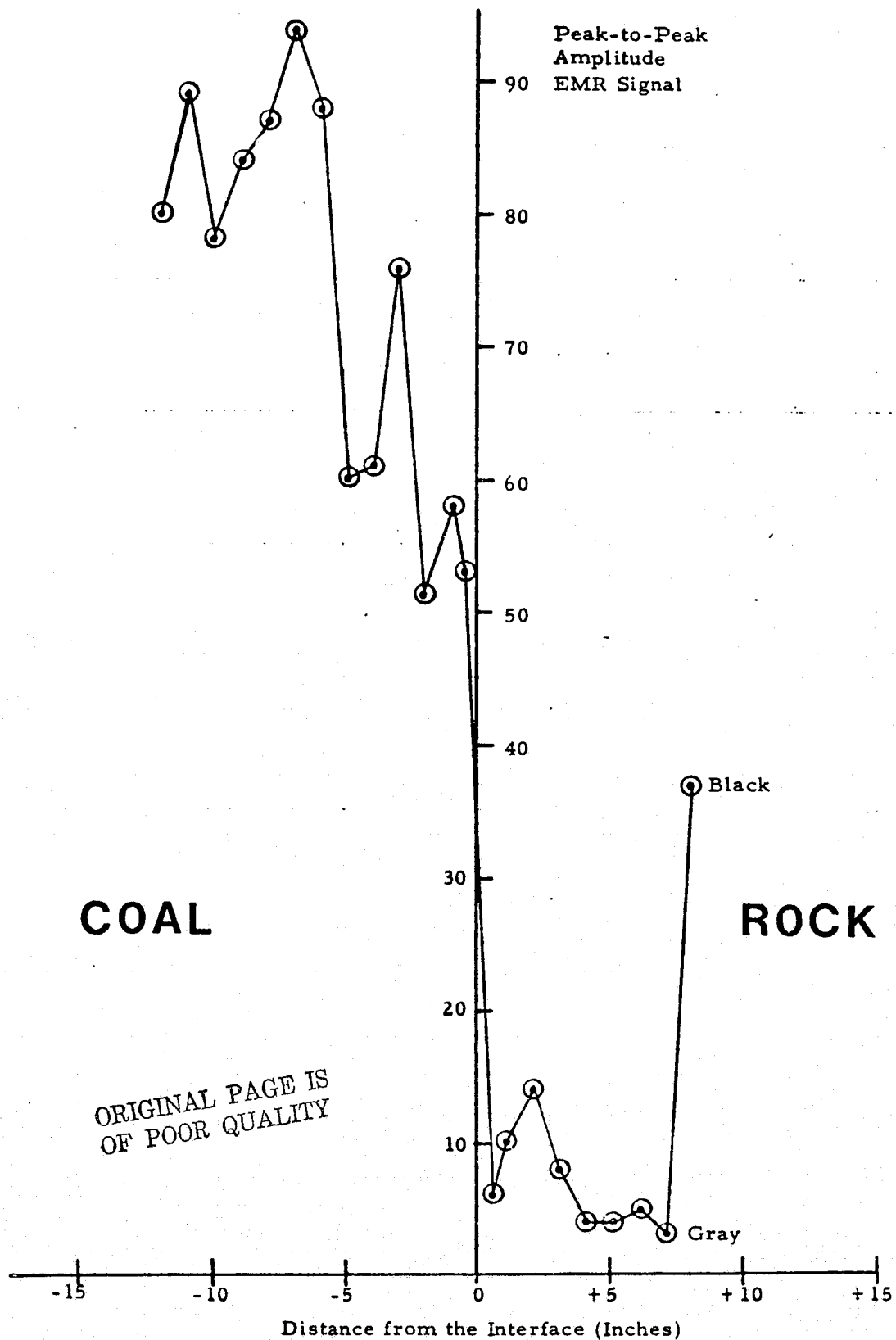

FIGURE 10. GRAPH OF THE PEAK-TO-PEAK VALUES OF THE ELECTRON MAGNETIC RESONANCE SIGNALS FROM SAMPLES TAKEN AT VARIOUS DISTANCES AROUND THE SECOND INTERFACE (Position 2) OF THE FIRST SUPPLY OF SAMPLES

the two values of 15 to 1 and 2.6 to 1 obtained at positions 1 and 5 on the first interface. Therefore, the EMR signals provide a good definition of the interfaces 1 and 2.

Although not shown by the data graphed in Figure 10, the intensities of the signals graphed in Figure 10 were increased by 1.285 relative to the intensities in Figures 8 and 9. This difference must be kept in mind when comparisons are made.

An examination of the graph in Figure 10 and a comparison of Figure 10 with Figures 8 and 9, on the coal side, show a definite difference between the data from interface 2 and interface 1. Around interface 1 the amplitude of the coal signal "holds up" or has the same average value close to the interface as far from it; around interface 2, the average value of the coal signal has a lower value of about 60 from zero to -5 and a higher value of around 85 from -5 to -13. This change may mean that the concentration of the free electrons in the coal has dropped from -5 to zero which would be in accord with statements made by coal mining experts that the coal close to the interface is sometimes of lower quality than that far away from the interface, and statements in the EMR literature that coal of lower quality contains a lower concentration of free electrons, at least for coals from lignite through bituminous.

Another examination of Figure 10 shows an anomalously high value for the last rock sample or the one from 8 inches into the rock. To explain this anomaly, comparisons were made between the colors of the

samples at 7 inches and at 8 inches, as well as the positions of the sample at 8 inches and the coal vein just above it. The two samples, one at 7 and one at 8 inches, had different colors; the one at 7 inches was gray like the rest of the rock, while the one at 8 inches was black like the coal samples. The sample at 8 inches was only 1.5 inches (see Figure 1) from the coal vein just above it. Therefore, it was assumed that the sample from 8 inches into the rock from interface 2 was either a piece of coal or rock with a very high concentration of coal like "wild-coal". To give more credulance to these two assumptions, it would be necessary to have more samples from different positions around interface 2.

The graph of data from position 3 is given in Figure 11. From the comparison of this data with the previous data one would conclude that the interface defined by the EMR signals extends from -7 inches to +7 inches. This may or may not be true. Since color comparisons had helped in the anomaly in Figure 10, the colors of most of the samples were estimated visually and the results written by the value in Figure 11. Both of the samples at the interface which had signal values of 33 and 55 were respectively brown and black. The large rock EMR signal of 57 at 3 inches comes from a sample which is black. Here again it must be understood that these first series of samples were very small in size and, since rock sometimes contains small layers of coal, small rock samples have a distinct and finite probability of being either rock or coal.

4577

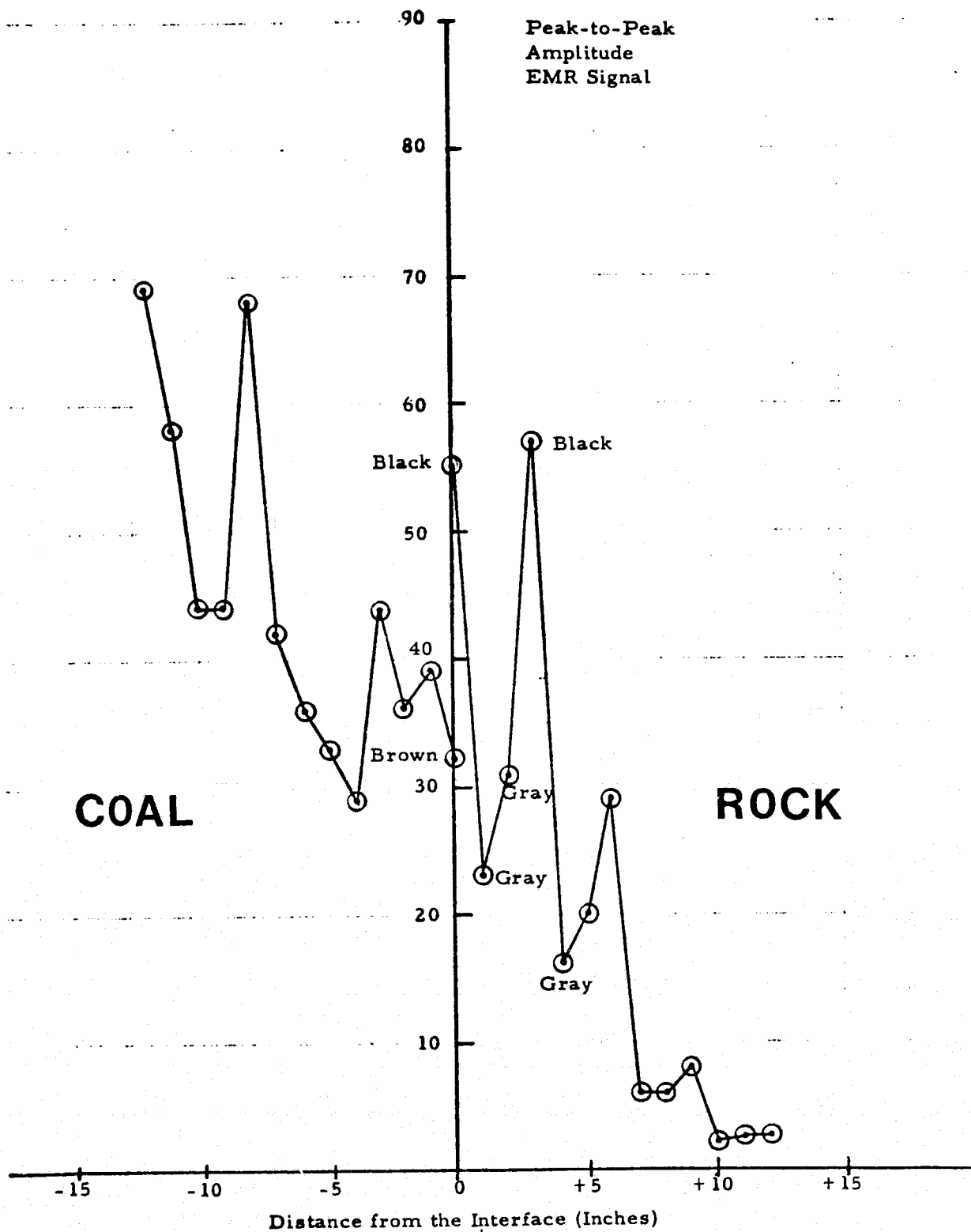

ORIGINAL PAGE IS
OF POOR QUALITY

FIGURE 11. GRAPH OF THE PEAK-TO-PEAK VALUES OF THE ELECTRON MAGNETIC RESONANCE SIGNALS FROM SAMPLES TAKEN AT VARIOUS DISTANCES AROUND THE THIRD INTERFACE (Position 3) OF THE FIRST SUPPLY OF SAMPLES

An improved procedure for setting the attenuator on the type EM-500 spectrometer gave better results so the data from the samples around position 3 was taken again. The graph from the new data with each sample color is given in Figure 12. Some of the large scatter in data was reduced by the new procedure but the EMR signals did not display an abrupt interface. There was little difference between the number of free electrons in the essentially brown-colored coal from -10 to zero and the number of free electrons in the gray and dark-gray colored rock from zero to +6. Beyond +6, the rock is light gray in color and the EMR signals from those samples were below 10 units in magnitude.

The graph of the EMR signals from the samples around the fourth interface (position 4) is given in Figure 13. Again the color of each sample is stated by its value. The layers on both sides of the fourth interface are small and the number of samples small. While the graph shows promise of a medium-well defined interface, with a change of from 41 to 7.5 in EMR signals, more samples are needed.

2. Coal-Rock Interfaces - Second Series Samples

The second series of samples were seven fist-sized chunks. Four small-sized samples were taken from each larger-sized sample, and were chosen to represent the range of colors present in the various layers. The EMR signals from these four replicates of each collection point were normalized and averaged. The graph is given in Figure 14 of the average values and extremes of the peak-to-peak EMR

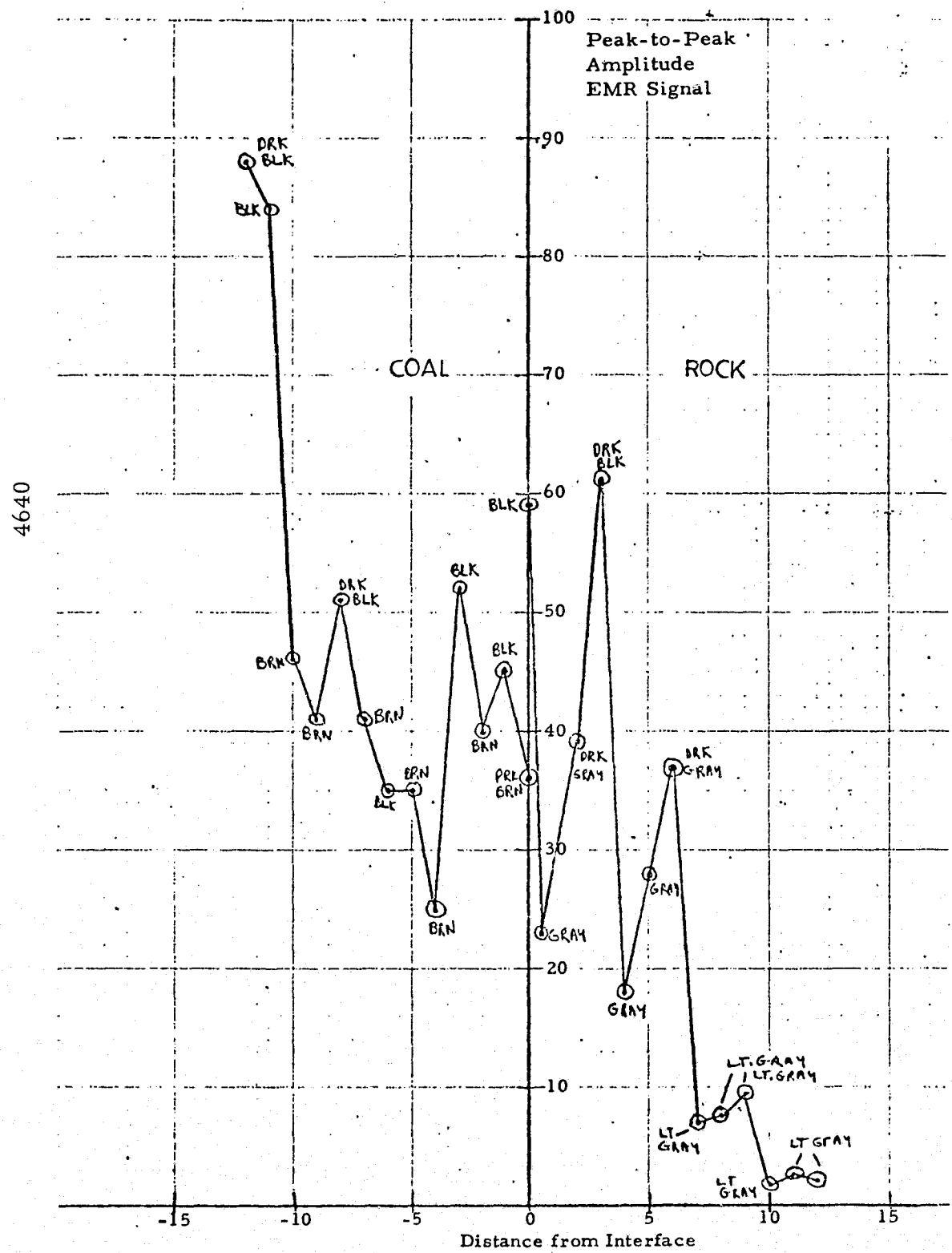

FIGURE 12. GRAPH OF THE PEAK-TO-PEAK VALUES OF THE REPEAT ELECTRON MAGNETIC RESONANCE SIGNALS USING AN IMPROVED ATTENUATION ADJUSTMENT TECHNIQUE, FROM THE SAMPLES TAKEN AT VARIOUS DISTANCES AROUND THE THIRD INTERFACE (Position 3) OF THE DRUMMOND STRIP MINE

ORIGINAL PAGE IS OF POOR QUALITY

4578

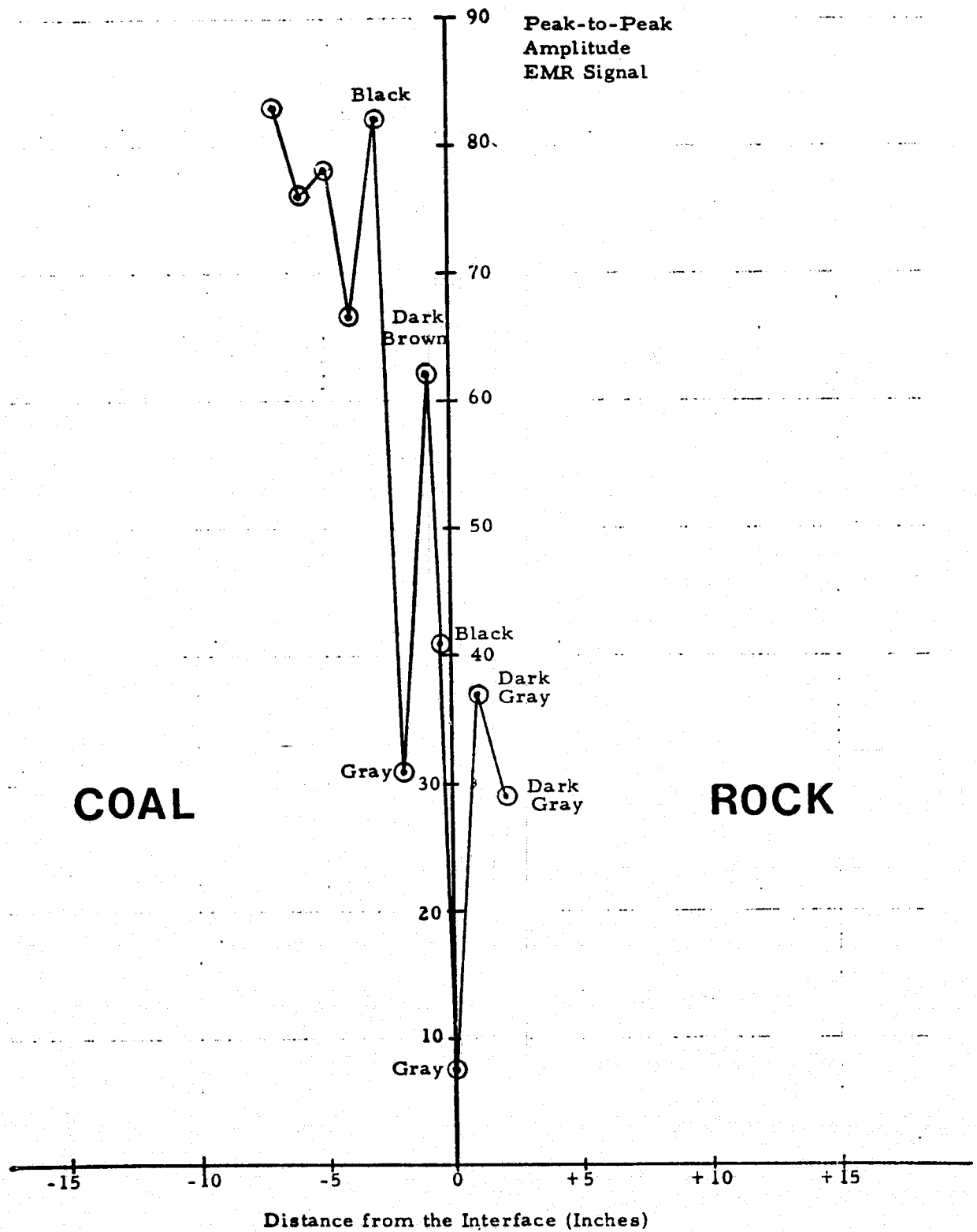

FIGURE 13. GRAPH OF THE PEAK-TO-PEAK VALUES OF THE ELECTRON MAGNETIC RESONANCE SIGNALS FROM SAMPLES TAKEN AT VARIOUS DISTANCES AROUND THE FOURTH INTERFACE (Position 4) OF THE FIRST SUPPLY OF SAMPLES

4639

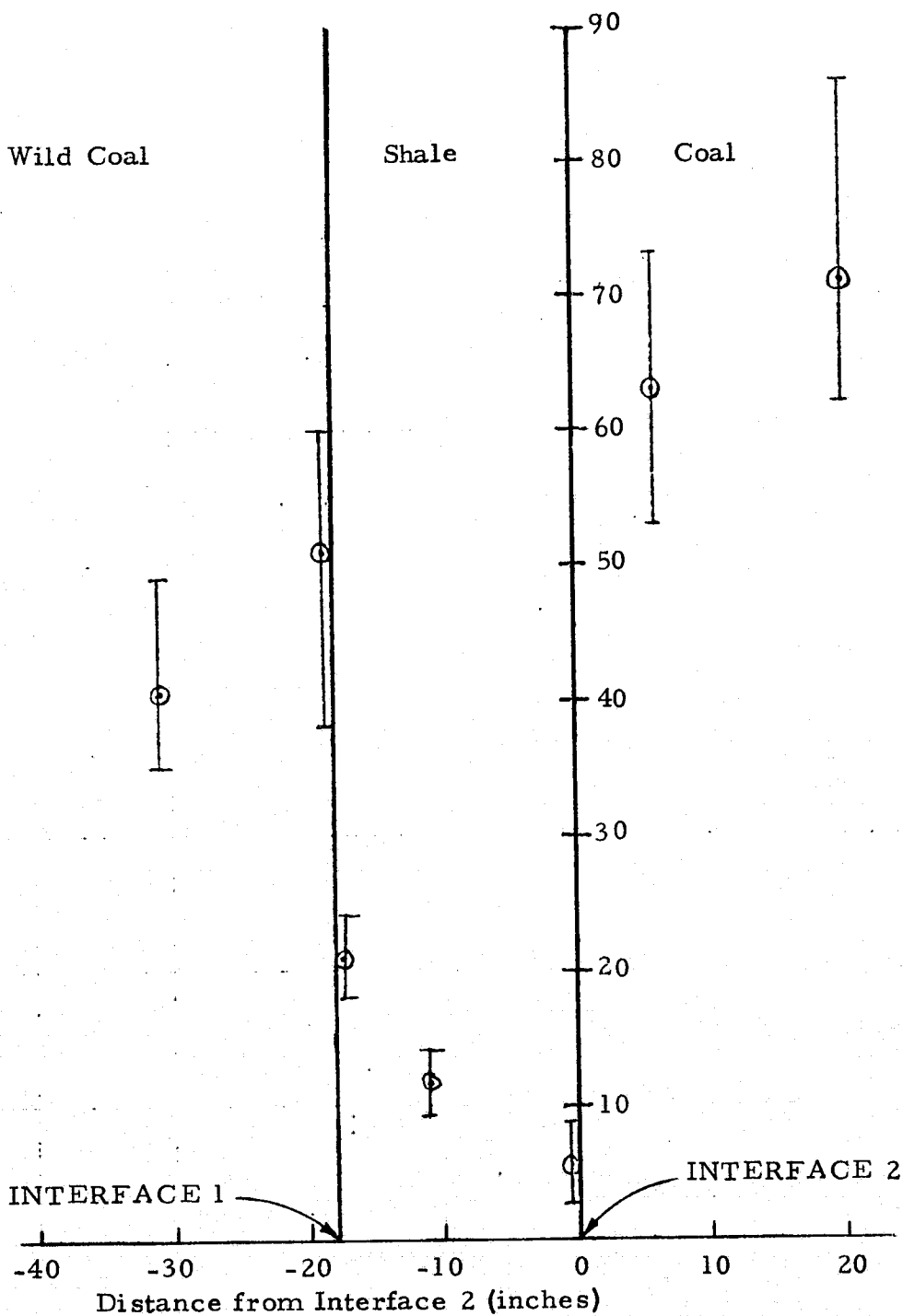

FIGURE 14. GRAPH OF THE MEAN VALUES AND LIMITS OF THE PEAK-TO-PEAK EMR SIGNALS FROM THE FOUR REPLICATES FROM EACH OF THE SEVEN SAMPLES FROM THE BRUCETON MINE

ORIGINAL PAGE IS
OF POOR QUALITY

signals from the four replicates at each collection point. One of the samples was indicated as coming from the coal-shale interface (see Fig. 2) and two others from the wild-coal-to-shale interface. However, the samples indicated from the same interface did not give the same magnitudes of signals. It was at this point that it was noticed that there were different position indicating arrows (see Fig. 2) attached to each of the three samples at the two interfaces. These arrows were interpreted to mean the following:

- . sample No. 5 came from the wild-coal side of interface p, series 2
- . sample No. 4 came from the shale side of interface 1, series 2
- . sample No. 2 came from the shale side of interface 2, series 2

When the signal amplitudes were graphed following the foregoing three position assumptions, the results given in Figure 14 were obtained and the magnitudes all fell into place.

The following conclusions can be made from the EMR signal responses obtained from the samples from the Bruceton mine:

- (1) The wild-coal EMR response produces a detected signal having an average peak-to-peak voltage amplitude of 46 (relative units). The peak-to-peak range of voltage variation observed from sample to sample extends from 35 to 60 units. A voltage unit in this case is one division on a chart recording of the EMR response.

- (2) The shale EMR signals have an average peak-to-peak amplitude of 13 units and the sample-to-sample range extends from 2.8 to 24 units.
- (3) The coal EMR signals have an average peak-to-peak voltage amplitude of 69 units and the sample-to-sample range extends from 53 to 86 units.

These values are within the amplitude ranges of the EMR response signals obtained with corresponding coal and rock samples from the Drummond Strip Mine.

3. Data Analyses

The data from the first series of samples were used for distributional analyses. The peak-to-peak EMR signal amplitudes ranged from a few divisions to 100 divisions (relative voltage units). This total range (from zero to 100) was divided into 20 "slots", each 5 units wide. A graph was then made of the number of measurements from the rock and from the coal which fell into each "slot". Figure 15 is the distribution graph for the rock samples. A total of 37 samples were measured from the rock and 26 of them, or 70.2% of the total, had EMR response values below 15 units. More than 50% are below 10.

Figure 16 is the distribution graph for the EMR signals obtained from the coal samples. A total of 46 coal samples were received and all but 5 (or 89%) exhibited EMR signal response amplitudes ranging between 50 and 95 units.

ORIGINAL PAGE IS
OF POOR QUALITY

4646

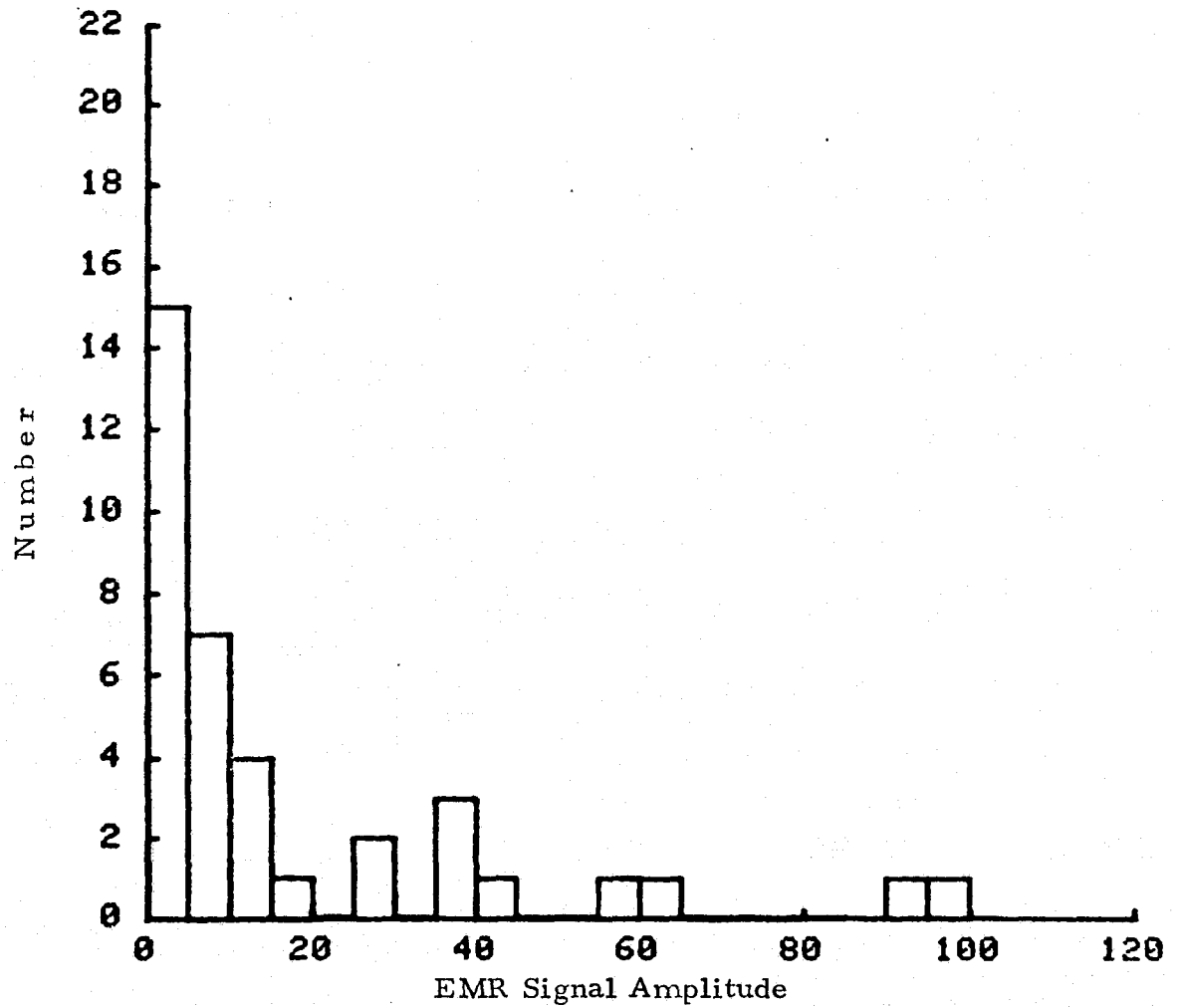

FIGURE 15. DISTRIBUTION GRAPH FOR THE NUMBER OF VALUES OF THE EMR SIGNALS FROM THE ROCK SAMPLES FROM THE DRUMMOND STRIP MINE AS A FUNCTION OF SIGNAL AMPLITUDE.

4647

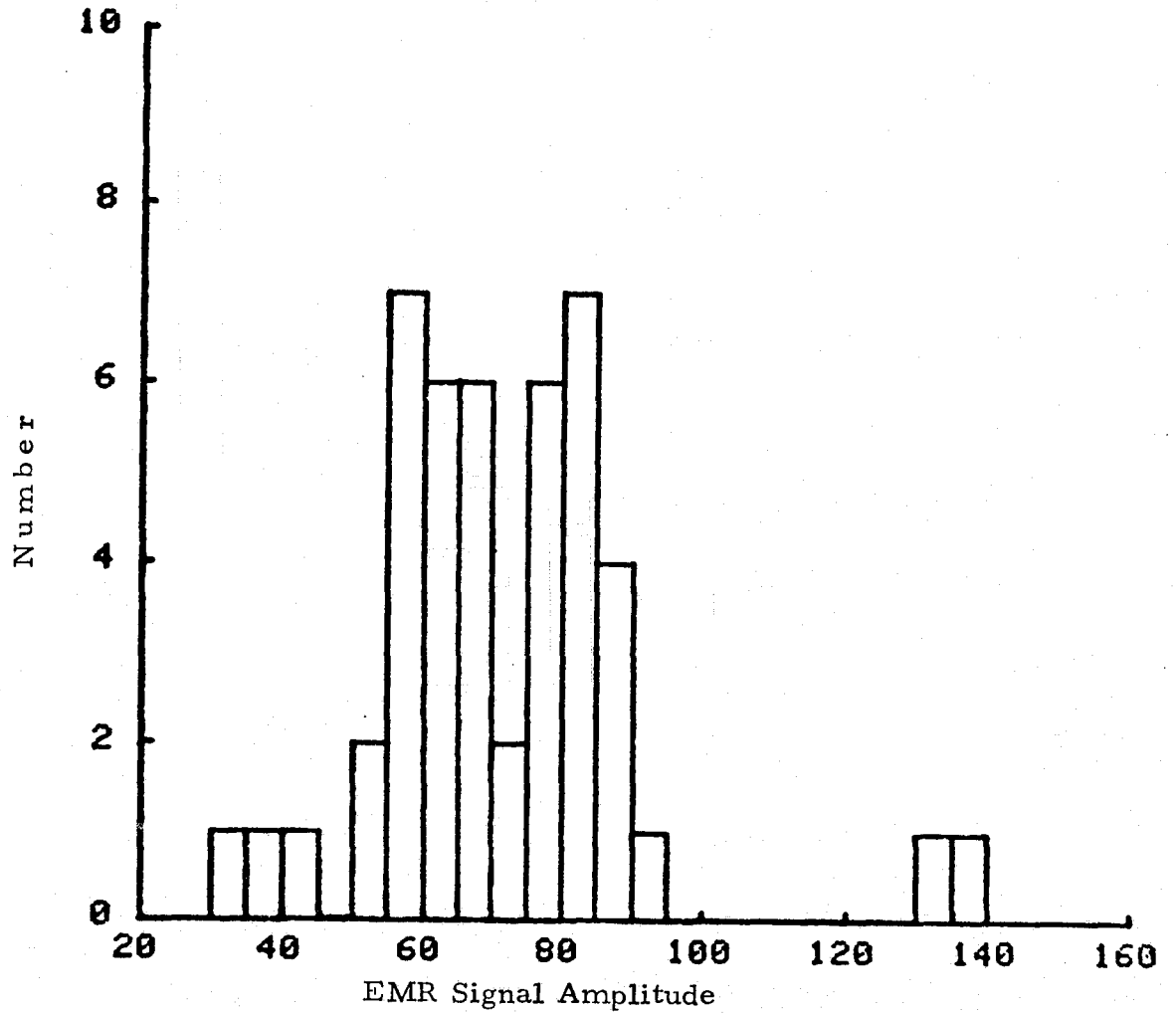

FIGURE 16. DISTRIBUTION GRAPH (number vs. signal amplitude) FOR THE EMR SIGNALS FROM THE COAL SAMPLES FROM THE DRUMMOND STRIP MINE.

ORIGINAL PAGE IS
OF POOR QUALITY

B. Results of Low Frequency Studies

1. EMR Equipment for 154.5 MHz

The equipment assembled to obtain EMR signals at low magnetic fields of 50 to 60 Gauss (140 MHz to 168 MHz) followed the block diagram of Figure 17. The equipment shown as blocks in Figure 17 was available at SwRI as were the magnet and the modulation coils. The remainder of the equipment was designed and constructed specifically for this application. Of several bridge configurations, balancing arrangements and matching networks, which were evaluated that shown in Figure 17, provided the best performance.

With the proper adjustment the detection coil (L) and the matching network (C_1 and C_2), the bridge could be tuned to be sensitive to resonance absorption signals at 154.5 MHz. The generator was then set to this frequency and C_4 , C_3 and R were adjusted to give a null at the output of the bridge, point c. Although great care was not taken in construction and flexible coaxial cable was used for the four arms, the output of the bridge could be readily balanced to -30 dBm.

With an 18 Hz modulation frequency, the EMR signal was a very small 18 Hz modulation of the output of the bridge. This modulation exhibited both amplitude (absorption) and phase (dispersion) components. The balanced mixer, when connected as shown in Figure 17, acts as a phase-sensitive detector which could be adjusted to more strongly detect either the amplitude or absorption component of the modulation on the bridge output.

4783

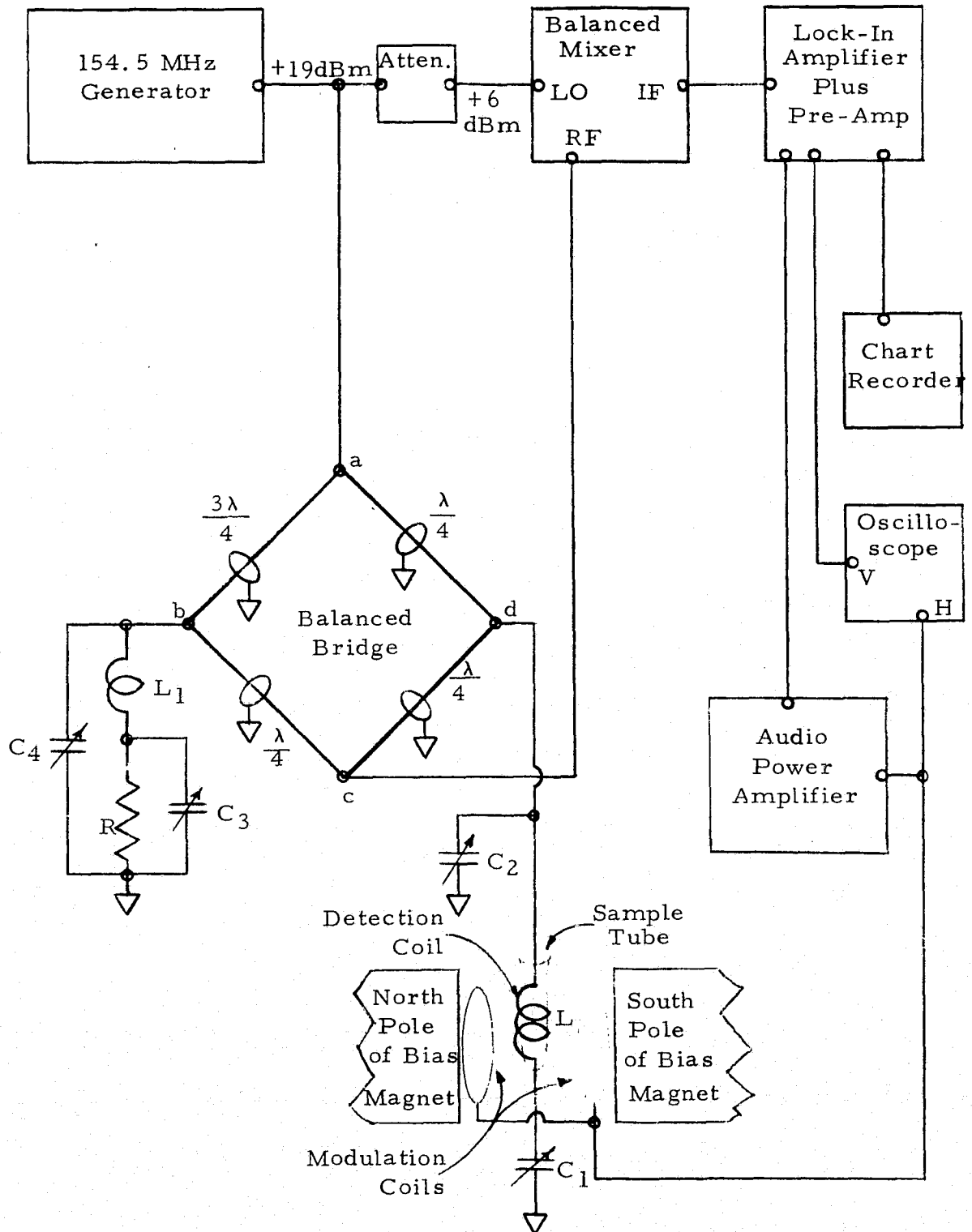

FIGURE 17. BLOCK DIAGRAM OF THE EXPERIMENTAL APPARATUS ASSEMBLED TO OBTAIN ELECTRON MAGNETIC RESONANCE SIGNALS AT 154.5 MHz FROM SAMPLES

ORIGINAL PAGE IS OF POOR QUALITY

The Lock-In amplifier is essentially a narrowband filter centered on 18 Hz plus a phase-sensitive detector at the same frequency. The Lock-In amplifier output signal is recorded on the chart recorder. This recorded signal is a voltage vs. time plot of the derivative of the absorption component of the EMR signal such as those produced by the Varian Spectrometer at an operating frequency of about 10 GHz and shown in Figures 3-5. A representative EMR signal from coal at 154.5 MHz is reproduced in Figure 18.

2. EMR Signals from Coal at 154.5 MHz

For the initial tests, the 0.5" (1.25 cm) diameter by 0.5" (1.25 cm) long detection coil (L) was filled with a test tube containing a sample of coal. The detection coil containing the sample was placed in the homogeneous magnetic field, H_0 , of an electromagnet and the 18 Hz signal from the audio amplifier was applied at an appropriate level to the modulation coils. The modulation coils were oriented to produce an A.C. magnetic field component in parallel to the field, H_0 . After adjustment of the apparatus for proper operation, the intensity of the field H_0 was caused to slowly sweep over a range of values centered about that (55.2 gauss) required for EMR at the operating frequency of 154.5 MHz. As the field intensity was swept through the range required for EMR, the derivative curve as shown in Figure 18 was produced. To gain a better insight into the characteristics of the coal EMR response at these low frequencies, several tests were performed.

4784

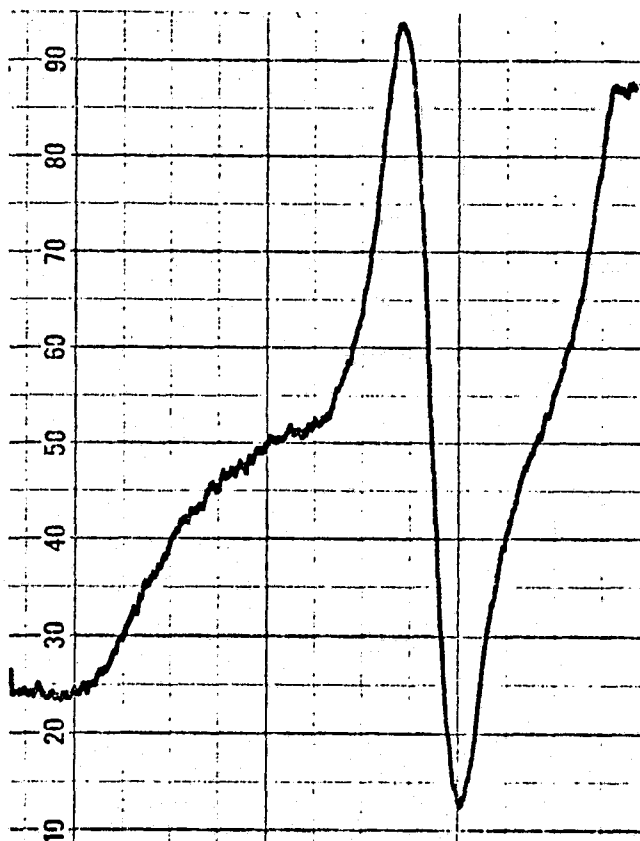

FIGURE 18. RECORDING OF THE ELECTRON MAGNETIC RESONANCE SIGNAL AT 155 MHz FROM THE FREE ELECTRONS IN A REPRESENTATIVE SAMPLE OF COAL

To test for the effect of modulation on the signal, the voltage level into the modulation coils was varied and the EMR signals from the same coal sample recorded. The graph of the peak-to-peak values for the coal EMR signals as a function of the modulation voltage is given in Figure 19. Above a modulation voltage of 6 volts, little additional increase in signal is obtained.

An increase in modulation should be accompanied by an increase in the width or the distance between the peaks of the recorded signal. The graph in Figure 20 shows that the linewidth has changed by 2.4 times as the modulation amplitude has varied from 0.5 volts to 6 volts.

The signal/noise ratio of the total EMR system can be calculated from the recorded signal reproduced as Figure 18. The maximum peak-to-peak value of the free electron signal from coal at 154.5 MHz is 108.5 millimeters while the peak-to-peak value of the noise is 2 millimeters. Therefore, the signal/noise ratio obtained is the ratio of the peak-to-peak values of the signal and noise times 2.5 or 135.6. This is a very good value considering that the output of the 154.5 MHz generator is considerably less than the amount estimated to provide the largest signal possible. With improved apparatus it is estimated that the signal/noise ratio could be increased by 6 to 8 times that shown in Figure 18 or to levels of between 814:1 and 1085:1. The signal/noise ratio estimated from basic principles ranges from a minimum of 1000 to a maximum of 10,000.

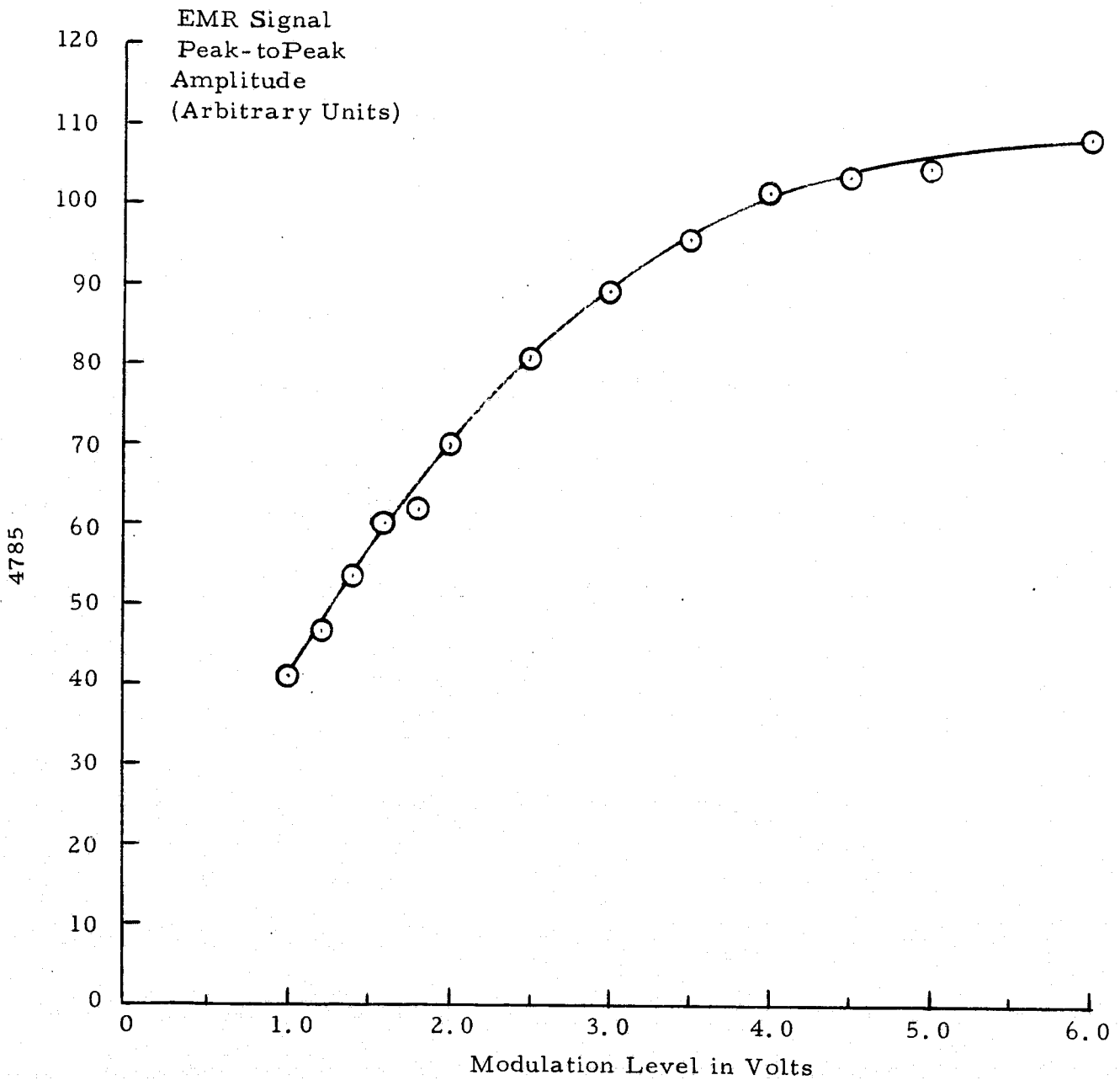

FIGURE 19. VARIATION OF THE AMPLITUDE OF THE EMR SIGNAL AT 155 MHz FROM COAL AS A FUNCTION OF MODULATION LEVEL

ORIGINAL PAGE IS
OF POOR QUALITY

4786

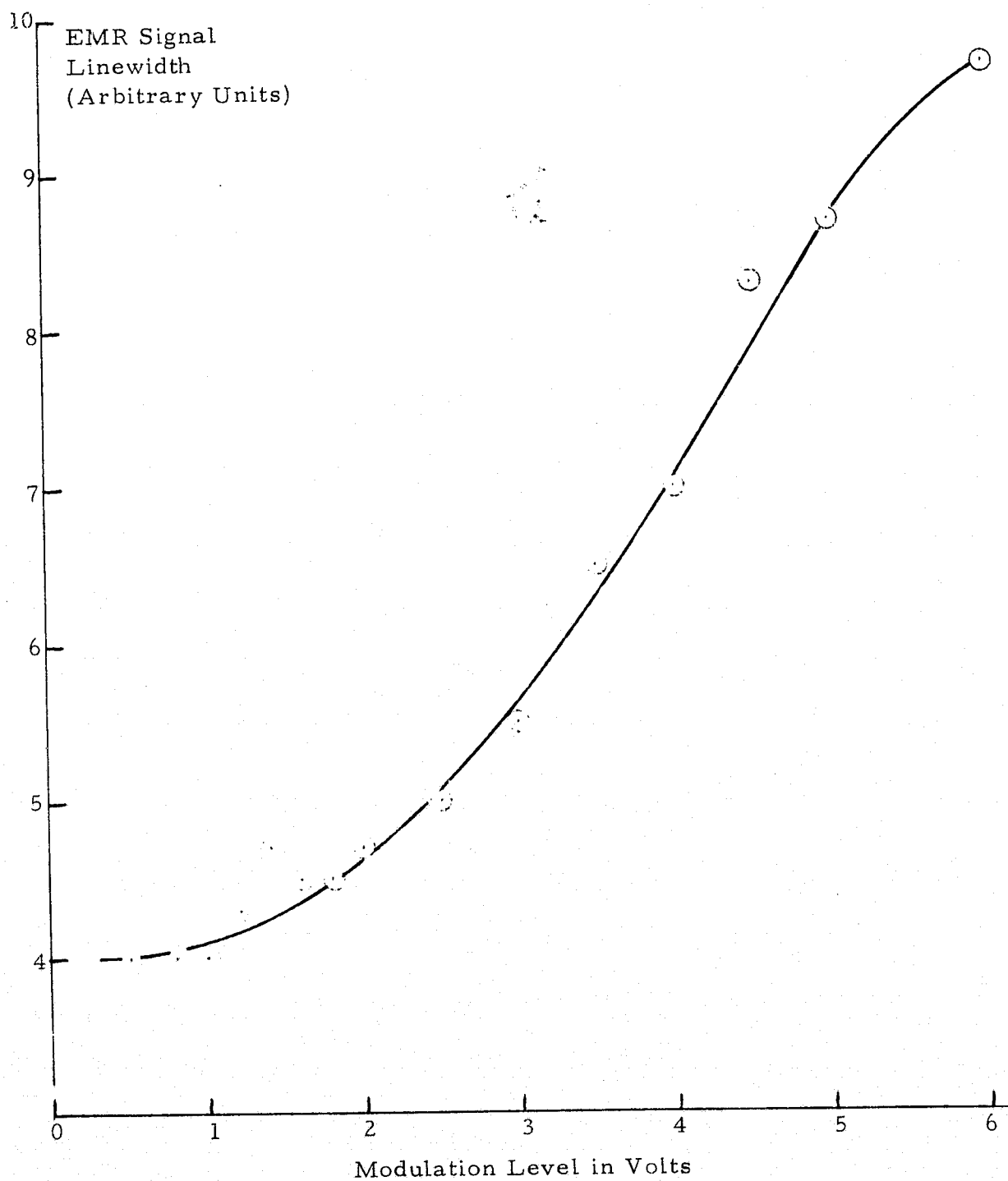

FIGURE 20. VARIATION IN THE LINEWIDTH OF THE RECORDED EMR SIGNALS AT 155 MHz FROM COAL AS A FUNCTION OF MODULATION LEVEL

ORIGINAL PAGE IS
OF POOR QUALITY

C. Results of Model Studies

1. Mathematical Model of the Detection Technique

To evaluate the feasibility of the EMR technique as applied to coal thickness measurement and for coal-rock interface detection, a preliminary mathematical model of one EMR detection technique has been developed. This model allows the measurement range, the measurement resolution and sensitivity variation with distance to be evaluated. The model is based on the use of a two-pole, U-shaped magnet structure with a radiofrequency detection coil located between and in the plane of the two magnetic poles. The magnet structure produces a magnetic bias field, H_0 . The RF coil is used with an appropriate transmitter, receiver and auxiliary apparatus to detect any EMR response from the material coupled to the coil. The magnetic bias field extends outward from the poles and can interact with unpaired electrons in material located within the field to produce an EMR at a frequency, f_0 . The EMR frequency, f_0 , is related to the magnetic field by

$$f_0 = \frac{\gamma H_0}{2\pi} \quad (1)$$

where

$$\begin{aligned} \gamma &= \text{gyromagnetic ratio of electron} \\ &= 17.61 \times 10^6 \text{ for free electrons} \end{aligned}$$

$$H_0 = \text{particular value of magnetic field intensity required for resonance expressed in Gauss}$$

Thus for a free electron

$$f_0 = 2.8 \times 10^6 H_0, \quad (2)$$

and if H_0 is 100 Gauss, the EMR resonant frequency is 280 MHz. The

field intensity, H , for a given pole strength is seen to vary as a function of distance and direction from the plane of the poles. Thus for a given magnetic pole strength, the EMR frequency for free electrons would vary as a function of location within the material. By adjusting the pole strength, the EMR frequency anywhere in the material can be made to be equal to any desired value, f_0 . By varying the pole strength over a selected range as a function of time, the particular field intensity H_0 required for EMR at frequency, f_0 , can be made to sweep through the material as a function of time. At any one time, the exact field intensity, H_0 , occurs along a line of constant flux density. By varying the pole strength, the intensity, H_0 , can be made to occur along any one of the family of curves of constant flux density. Since the EMR energy absorption curve has finite width, some response will be produced by electrons in material extending on each side of the exact, H_0 , line. The extent for a response equal to half of the center response is called the linewidth. Thus the detection system model selected for analysis makes use of a bias magnet which may be varied in intensity to cause EMR for a particular operating frequency, f_0 , to occur at any desired region within the material.

The radiofrequency coil and associated electronic circuitry detect the EMR response from the volume of material where the field intensity is within the EMR linewidth (about 5-8 Gauss in coal) of the resonance intensity, H_0 . Coal produces a large EMR response while rock has been found to exhibit only a very small EMR response. Thus if the magnetic field

intensity is such that H_0 occurs within a region filled with coal a relatively large EMR response will be obtained compared to that when H_0 occurs in the rock. As the field is varied, the resonance value, H_0 , is swept over a coal-rock interface and there will be an abrupt change in the detected amplitude of the EMR response at the interface. This can be used to define the location of the coal-rock interface. Similarly the abrupt change in the amplitude of the EMR response that is obtained as the field is varied to cause H_0 to sweep across the air-coal interface may be used to define the location of the front surface of the coal. By making use of the location of both points, the coal thickness may be determined.

The mathematical model is based on determining the EMR signal level that is obtained from material extending outward from the plane of the poles of the magnetic bias magnet and the radiofrequency detection (sample) coil. For analytical purposes the total EMR signal may be considered to be the sum of the contribution, dS , from all elemental volumes, dV , within the material. The amount of contribution from any one elemental volume is dependent on several factors including: (1) the distance from the detection coil; (2) the direction from the detection coil; (3) the angle between the magnetic bias field, H , vector and the radiofrequency magnetic field, H_1 , vector produced by the detection coil; and (4) the density of unpaired electrons (or free electron density) within the volume. The number of elemental volumes making a contribution is determined by:

(1) the gradient in the magnetic bias field; (2) the width of the EMR line; (3) the field shape resulting from the size and geometry of the bias magnet; and (4) the field shape resulting from the size and geometry of the radio-frequency detection coil.

The equation used in the preliminary model of the electron magnetic resonance coal-rock interface detection system based on the foregoing concept is

$$dS_m = dS_o(A)(B)(C)(D) \quad (3)$$

where

dS_m = the EMR signal induced in the sample coil by elemental volume dV_m

dS_o = the EMR signal induced in the sample coil by a reference elemental volume dV_o located in the center of and in the plane of the sample coil

(A) = normalized detection coil equation

(B) = normalized equation for the resonance absorption

(C) = normalized equation for the vector field angles involved

(D) = normalized equation for the coal-rock interface.

The detection coil equation is the one which gives the voltage induced into the detection coil from a small volume, dV , having a recessing magnetization, dm , from the free electrons. When the detection coil is circular with radius, a , then the detection coil equations are,

$$H_r = \frac{2NIz}{r[a+r]^2 + z^2}^{1/2} \left[-K(k) + \frac{a^2 + r^2 + z^2}{(a-r)^2 + z^2} E(k) \right] \quad (4)$$

ORIGINAL PAGE IS
OF POOR QUALITY

$$H_z = \frac{2NI}{[(a+r)^2 + z^2]^{1/2}} \left[+K(k) + \frac{a^2 - r^2 - z^2}{(a-r)^2 + z^2} E(k) \right] \quad (5)$$

where H_r is the radial component, H_z is the z-axis component, $K(k)$ and $E(k)$ are elliptic integrals of the first and second kinds, and the modulus, k , is

$$k^2 = 4ar [(a+r)^2 - z^2]^{-1} \quad (6)$$

For use in Equation (3), Equations (4) and (5) are normalized with the values of H_r and H_z when $r = 0$ and $z = 0$.

The normalized equation for the EMR absorption curve is

$$R = \frac{1}{1 + \left(\frac{H - H_0}{\Delta H/2} \right)^2} \quad (7)$$

where H_0 is the resonance value of the bias magnetic field, H is the value to which the bias magnetic field is set at any instant, and ΔH is the width of the resonance absorption curve (line) at half-amplitude.

The angles involved vary from place-to-place and are those between the vector of the radiofrequency magnetic field H_1 and the vector of the bias magnetic field H_0 . The equation in the plane including H_0 and H_1 is,

$$A = \sin \phi \quad (8)$$

where \emptyset is the angle between the H_1 and the H_0 field vectors. When the angle is 90° , the value of A is unity.

The normalized equation for the interface is a step-function which, if assumed to be unity on the coal side of the interface, has an experimentally determined value of 0.154 on the rock side. The value of 0.154 is based on the average values for the samples of rock and coal from the first interface of the Drummond Strip Mine.

The normalized angle equation is obtained from the equations for the field of the radiofrequency detection coil and the bias magnetic field. The magnitudes and directions for the bias magnetic field, H, will be shown later in the section on computer calculations.

The graphs of some representative curves for three of the four parts of the model Equation (3) are shown in Figure 21. The bias field curve, a, shows the intensity of H along a line which is perpendicular to the plane of the magnetic poles and the sample coil, and centered between the two magnetic poles. The bases are a center-to-center spacing between poles of 10 inches, a pole width of 5 inches and a fixed pole strength of one selected value. Curve b in Figure 21 is that of the radiofrequency magnetic field along the same line as a, based on a coil diameter of 4.5 inches. The resonance curve, c, shows the shape of the EMR response that would be obtained at a frequency of 100 MHz from an elemental volume located at 3 inches away from the detection head

4641

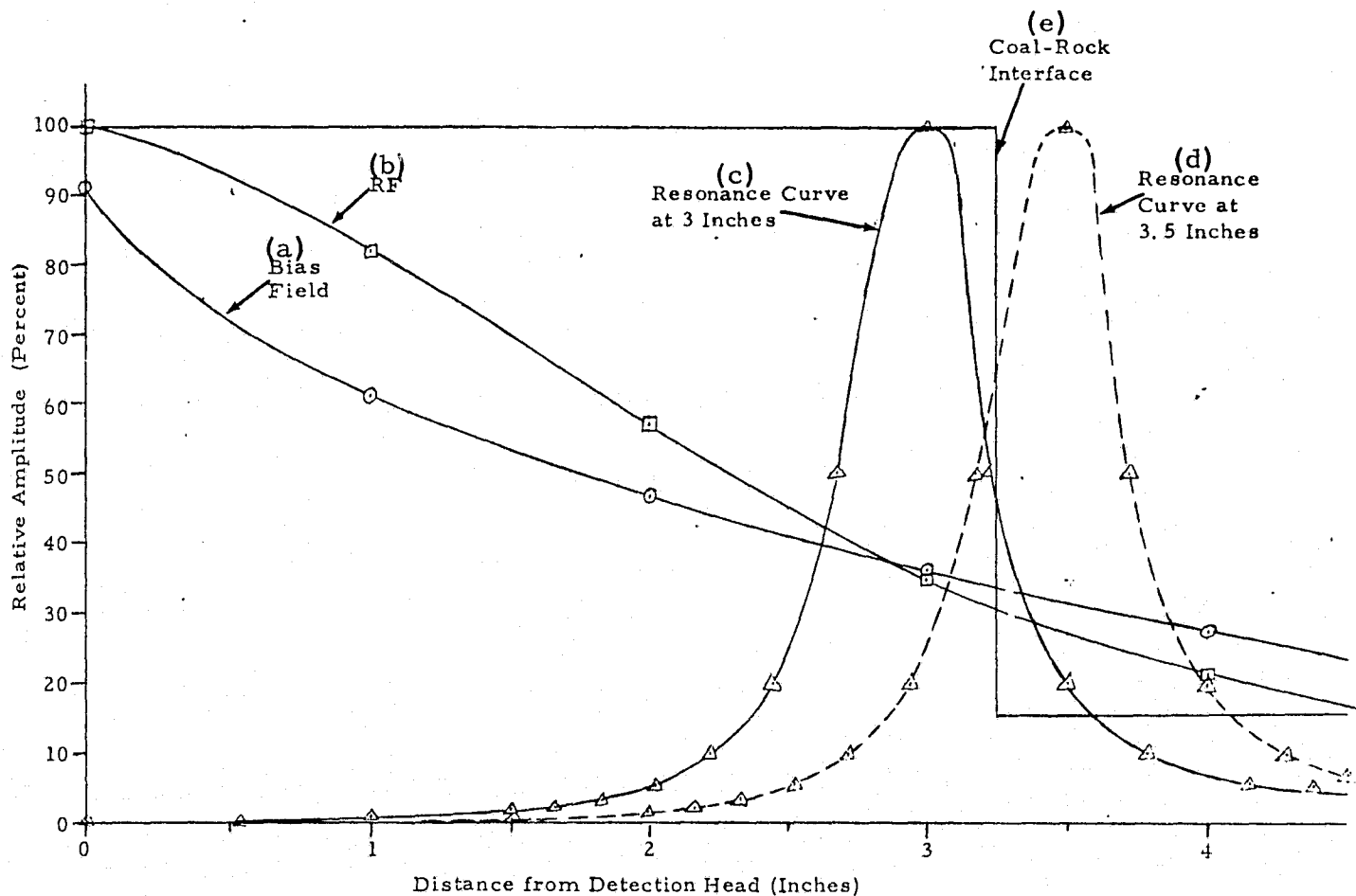

FIGURE 21. GRAPHS OF FOUR OF THE EQUATIONS USED IN THE MODEL FOR THE DETECTION OF COAL/ROCK INTERFACES WITH EMR SIGNALS FROM FREE ELECTRONS. (a) Graph of the bias field along the z axis, (b) Graph of the field from the RF or detection coil, (c) Graph of the resonance curve at 3 inches, (d) Graph of the resonance curve at 3.5 inches, and (e) Graph of the coal-rock interface

as the magnetic field is varied to cause the H_0 point to sweep from 0 to 4.5 inches away from the detection head. The resonance curve, d , is the shape of the EMR response that would be similarly obtained from an elemental volume located at 3.5 inches from the detection head. From these response curves it can be readily seen that, for the field gradient produced by the indicated bias magnet and the operating frequency of 100 MHz, a range resolution of much better than 0.5 inch is available. This is based on the width of the EMR line in coal and the specified field gradient conditions. A higher gradient would produce even better resolution.

The mathematical model was then put into a form where computations could be made with a model HP-2100 computer and plots of the results could be made on a Tektronix Model 4051 graphic computer.

2. Computer Analyses of Mathematical Model

Three separate computer programs were written to make up the system mathematical model. The first program modeled the bias magnetic field. The faces of the U-shaped electromagnet were replaced by a distribution of magnetic "poles", north types on one face and south types on the other. A north "pole" on one face made a dipole pair with a south "pole" on the other face. The magnetic fields of these dipoles were summed and the constant flux lines and surfaces were found. The second program was written to graph the constant flux lines as two dimensional cuts and isometric projections in two dimensions.

ORIGINAL PAGE IS
OF POOR QUALITY

The third program completed the model. The detection coil was modeled as a single-turn, circular loop since the equations for it are well known. The free electron concentration was modeled as a distribution of small permanent magnet dipoles and the field of each dipole was written in terms of elliptic integrals. For simplicity, it was assumed that the density of these dipoles was zero in air, zero in rock and had some finite value in coal. A radiofrequency pulse from the detection coil would cause these dipole magnets to rotate about the direction of the field from the detection coil. The angle of rotation was determined from the product of the length and strength of the pulsed radiofrequency field. This pulse length and strength was determined by the condition that a 90° rotation was obtained on the centerline of the bias magnet. The different values of rotation angle could then be determined at any point on the constant flux density surface for the bias field. The final angle of rotation for these magnets was complicated further by the fact that the angle between the radiofrequency field and the bias field directions varies along a constant flux surface. Once all of these factors were included and the difficulties worked out, the relative value of the EMR signal could be calculated and graphed for any point on a constant flux surface.

The first results of the computer program for the mathematical model were the graphs of the lines of constant flux density for different pole configurations of the bias magnet. The graphs of nine different values of constant flux density lines are given in Figure 22 for a

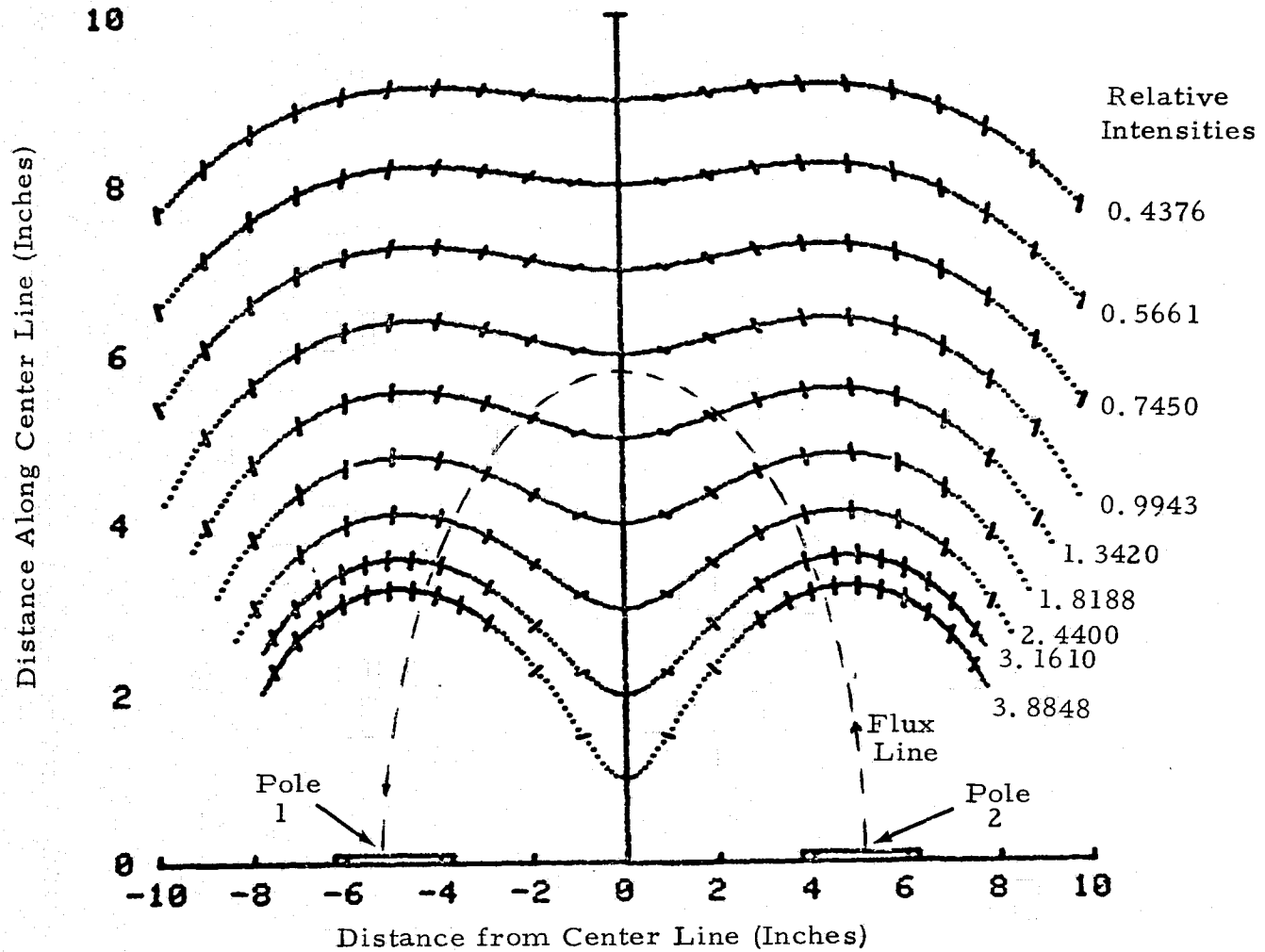

ORIGINAL PAGE IS
OF POOR QUALITY

FIGURE 22. CONSTANT FIELD INTENSITY CONTOURS PRODUCED BY TWO MAGNETIC POLES 2.5 UNITS WIDE SPACED 10 UNITS CENTER-TO-CENTER ($W/S = 4$)

U-shaped magnet having pole faces 2.5 units wide separated by 10 units center-to-center. The horizontal or x-axis is the distance from the centerline between the two poles and the vertical or z-axis is the distance away from the plane of the faces of the two poles. The marks on each line of constant flux density in Figure 22 give the direction of the bias field at that point in the xz plane. The dotted elliptically-shaped line in Figure 22 is one of the lines of flux. Along the z axis, the direction of the flux lines are parallel to the x-axis, perpendicular to the z-axis. In Figure 23 is a similar plot to that in Figure 22, but with the magnet poles increased to 5 units wide while keeping the same center-to-center pole separation of 10 units. Again a representative flux line is shown dashed.

To investigate the inhomogeneity of the fields, the program was changed to add the plus 5% and minus 5% lines around each line of constant flux density. The results for the two bias magnet configurations are given in Figures 24 and 25. As can be observed, the width of the $\pm 5\%$ lines changes slowly over the range plotted. Again, the short lines on the constant flux density lines give the directions for the fields at those points.

Again the plotting program was changed so that the three dimensional graph of the bias field could be made. The constant flux density value chosen was the one at $x = 0$, $y = 0$, $z = 0.5$. The resulting constant flux density surface is given in Figure 26. Further programming and work will be needed to give plots of constant EMR sensitivity.

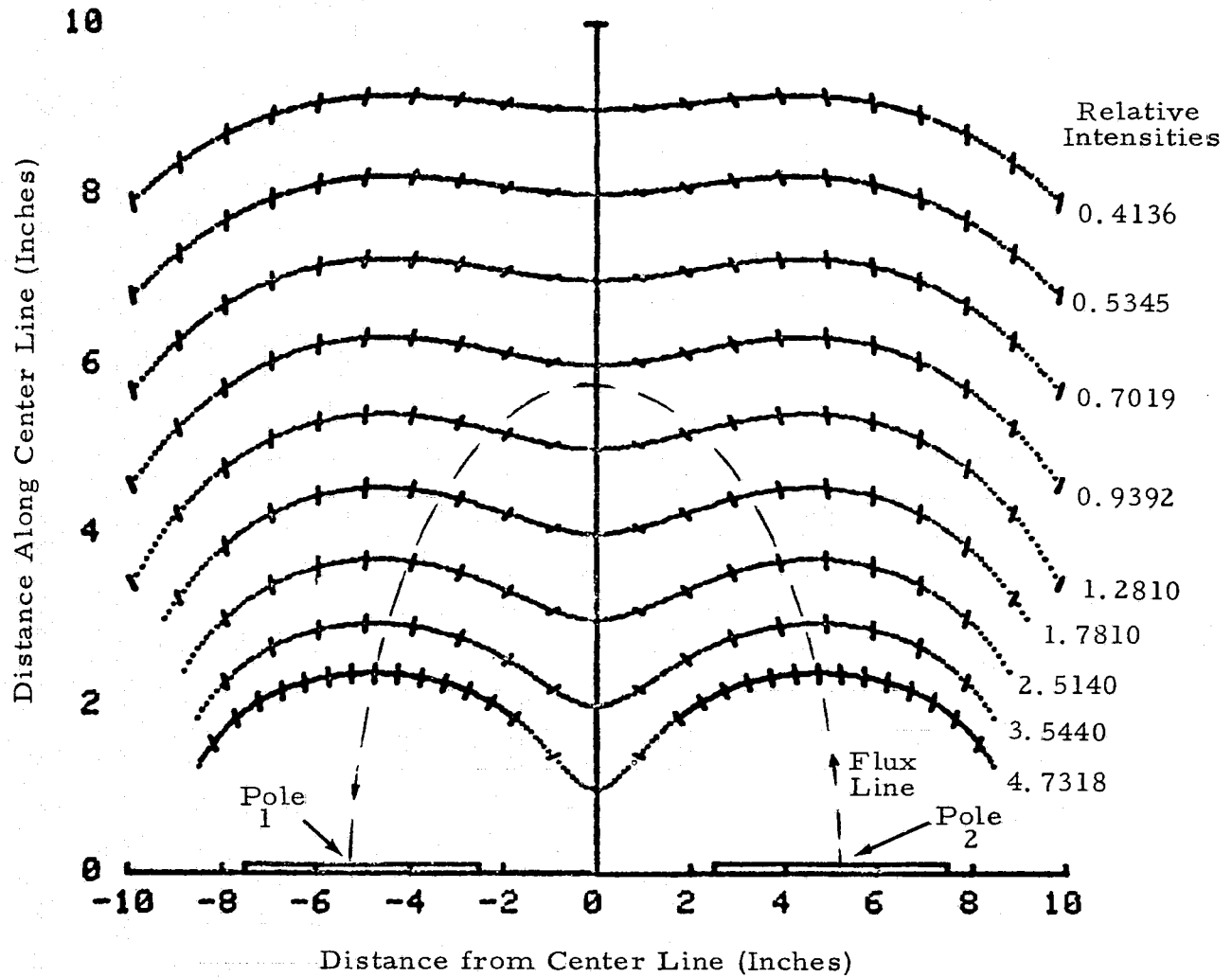

FIGURE 23. CONSTANT FIELD INTENSITY CONTOURS PRODUCED BY TWO MAGNETIC POLES 5.0 UNITS WIDE SPACED 10 UNITS CENTER-TO-CENTER ($W/S = 2$)

ORIGINAL PAGE IS
OF POOR QUALITY

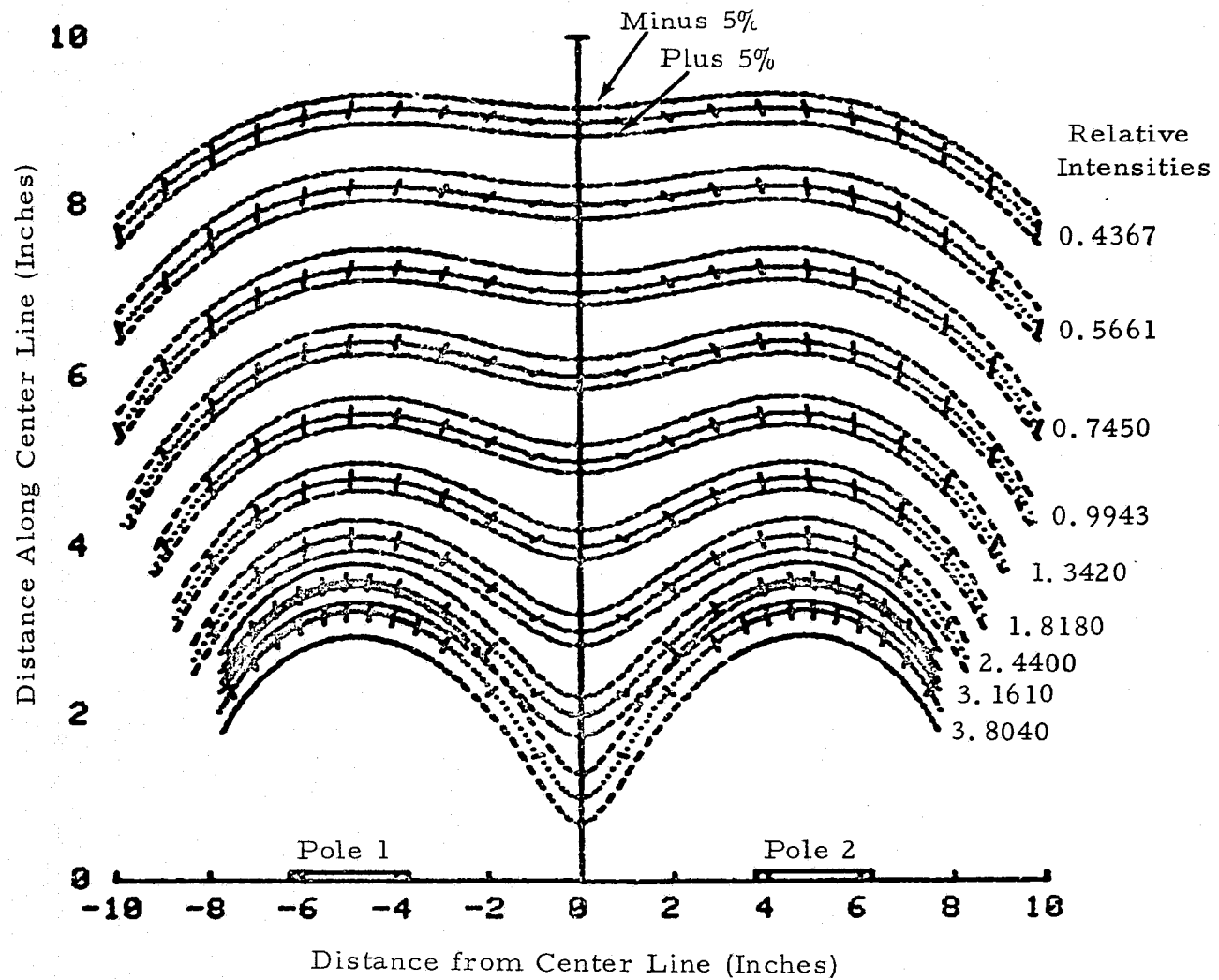

FIGURE 24. CONSTANT INTENSITY CONTOURS WITH $\pm 5\%$ LIMITS FOR TWO-POLE MAGNET WITH $W/S = 4$

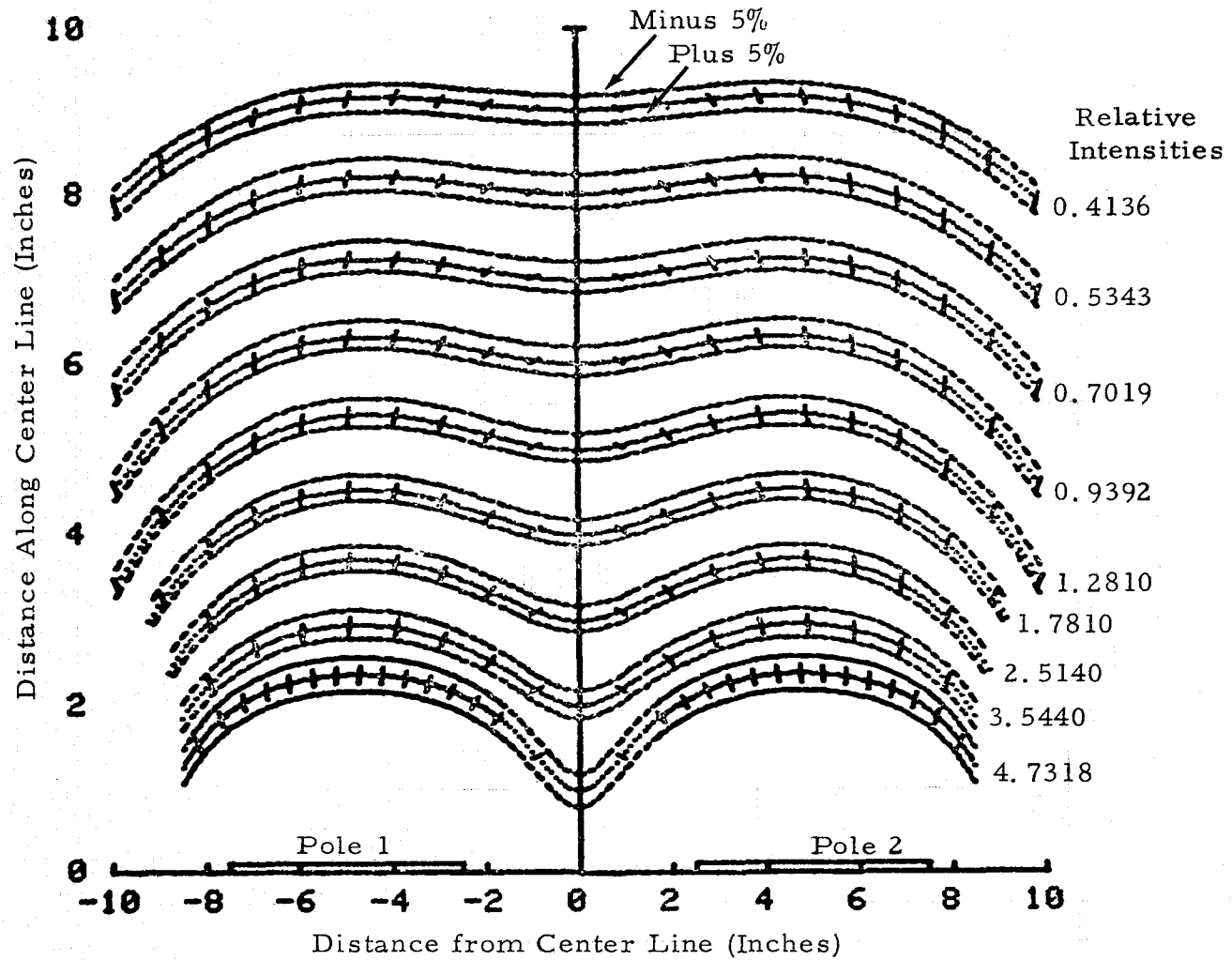
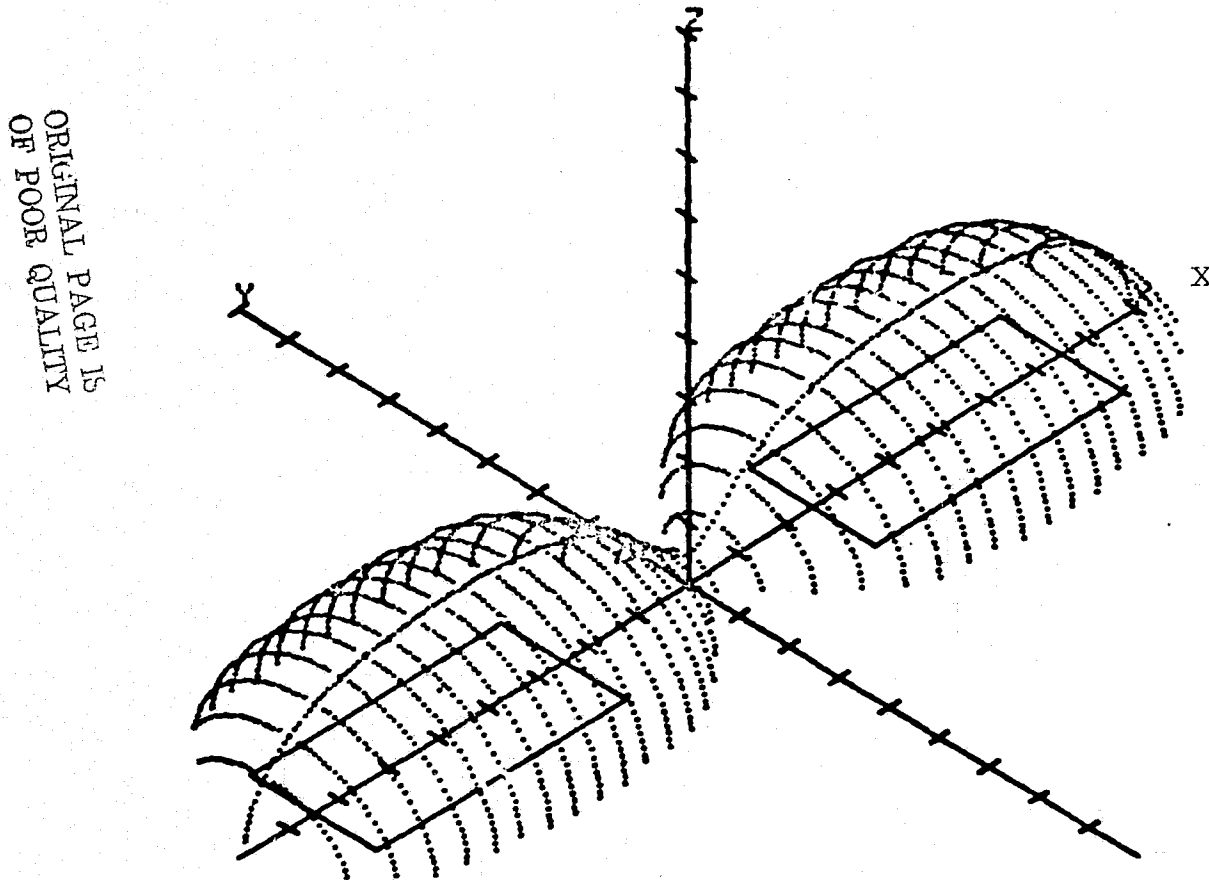

FIGURE 25. CONSTANT INTENSITY CONTOURS WITH $\pm 5\%$ LIMITS FOR TWO-POLE MAGNET WITH $W/S = 2$.

ORIGINAL PAGE IS
OF POOR QUALITY

T-D PLOT OF CONSTANT B SURFACE BEGINNING AT 0,0,.5



EACH TIC MARK IS ONE UNIT ALONG THAT AXIS

FIGURE 26. THE CONSTANT FLUX DENSITY SURFACE HAVING THE VALUE BEGINNING AT $(0, 0, 5)$ FOR THE TWO-POLE MAGNET WHOSE POLES ARE 5 UNITS WIDE, 2 UNITS DEEP, SPACED 10 UNITS.

The programs were again changed to draw the sensitivity or the strength of the EMR signal in the detection coil as the resonance value of the magnetic bias field is moved out along the z-axis at distances of from one to ten inches. The graph obtained with coal alone, as the resonance field value is varied from one to ten inches, is given in Figure 27. The numbers near the diamonds on the curve are the distances in inches while the horizontal scale is the current driving the bias electromagnet. With a coal-rock interface at two inches, the output of the detection coil (the EMR signal) would be as in Figure 28 for a one to ten inch scan of the magnetic field made by a 2 to 31 ampere change in the current of the bias magnet. The dotted curve is the change expected if the EMR signal had almost zero width.

When the coal-rock interface is placed at 5 inches, the signal would behave as in Figure 29. Again the dotted line would result if the EMR signal had almost zero width. With the interface at 9 inches, the curve in Figure 30 results.

The plotting program was then changed to give a graph at more points around the interface, and to make the horizontal variable "distance" instead of "magnet current". The first of these graphs, in Figure 31, was with a coal-rock interface at 5 inches. The computer plotted additional points every 0.1 inch from 4.5 inches to 5.5 inches. This plot in Figure 31 shows that the total signal change, for an instantaneous coal-rock interface, takes place over a length of 0.5 inch. When

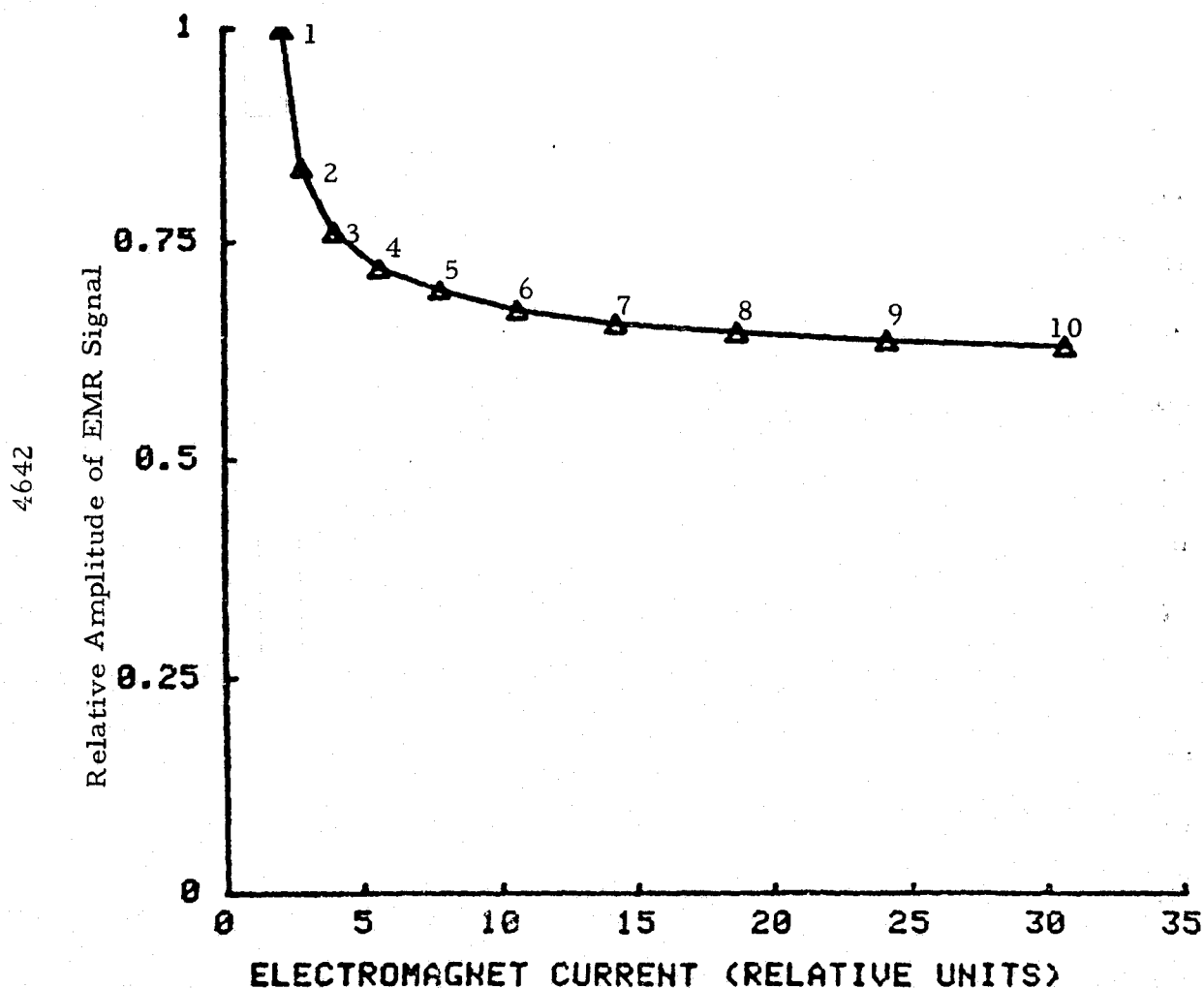

FIGURE 27. GRAPH OF THE AMPLITUDE OF THE EMR SIGNAL FROM FREE ELECTRONS RELATIVE TO THE VALUE AT A DISTANCE OF 1-INCH FROM THE DETECTION HEAD AS A FUNCTION OF THE CURRENT IN THE ELECTROMAGNET GIVING THE BIAS FIELD FOR THE CONDITION OF NO COAL-ROCK INTERFACE. The numerals by the triangles on the curve are distances in inches from 1 to 10 inches.

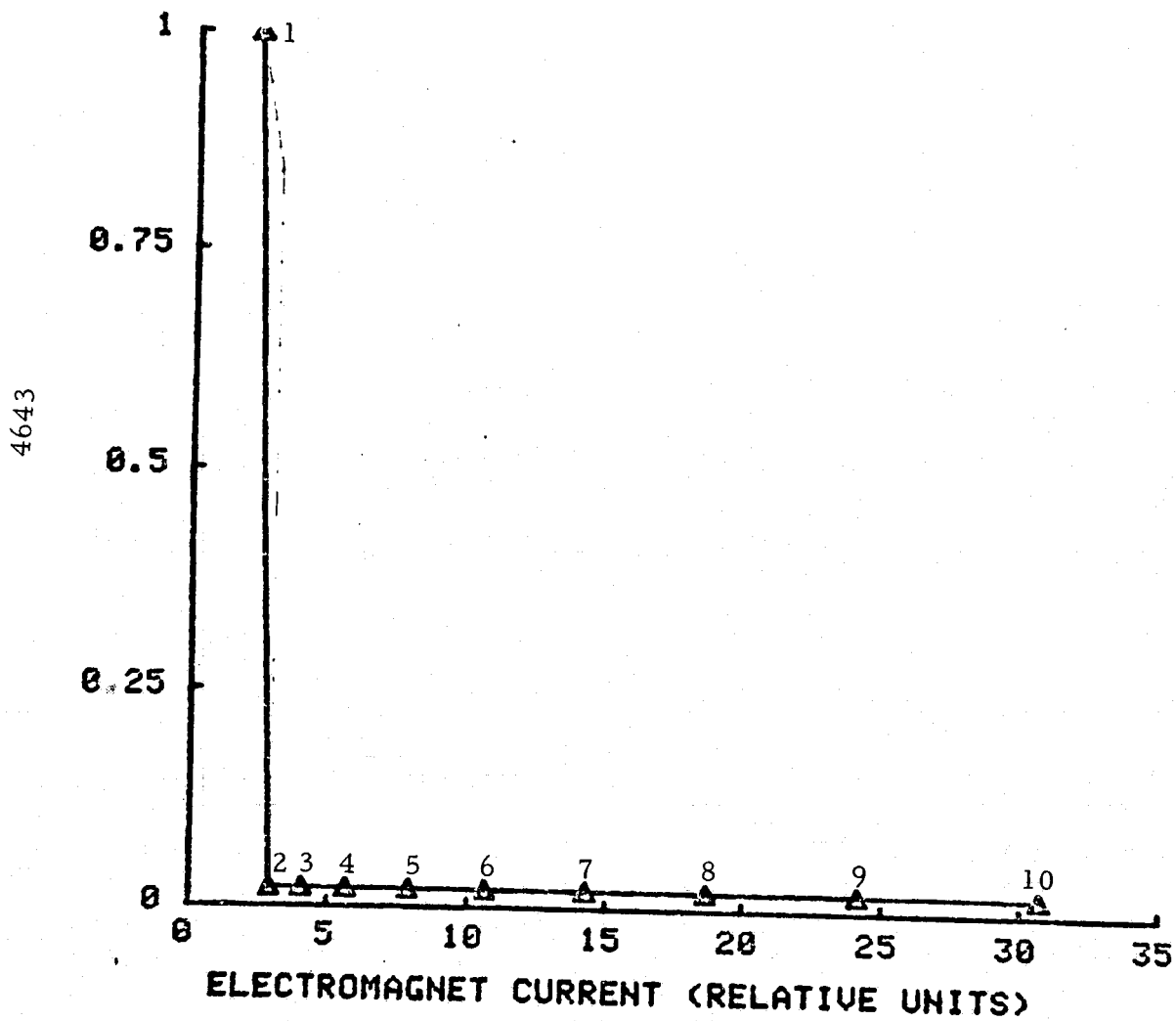

FIGURE 28. GRAPH OF THE AMPLITUDE OF THE EMR SIGNAL RELATIVE TO THE VALUE FOR COAL AT ONE INCH FROM THE DETECTION HEAD WITH A COAL-ROCK INTERFACE AT 2 INCHES. The dotted curve would be obtained if the computer plotted more points between 1 and 2 inches. The numerals by the triangles are the distances in inches.

ORIGINAL PAGE IS
OF POOR QUALITY

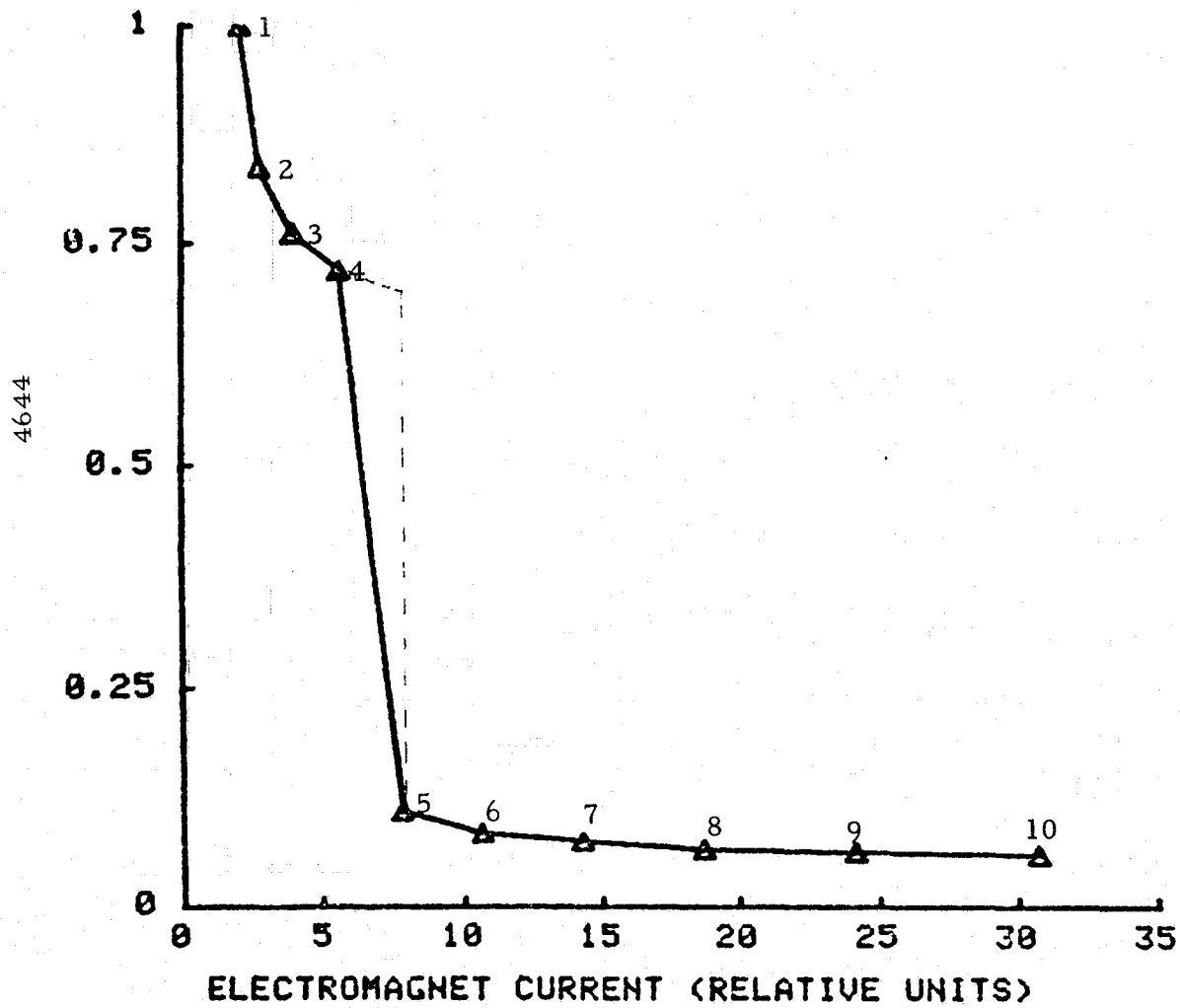

FIGURE 29. GRAPH SIMILAR TO FIGURES 27 AND 28 BUT WITH THE COAL-ROCK INTERFACE AT 5 INCHES

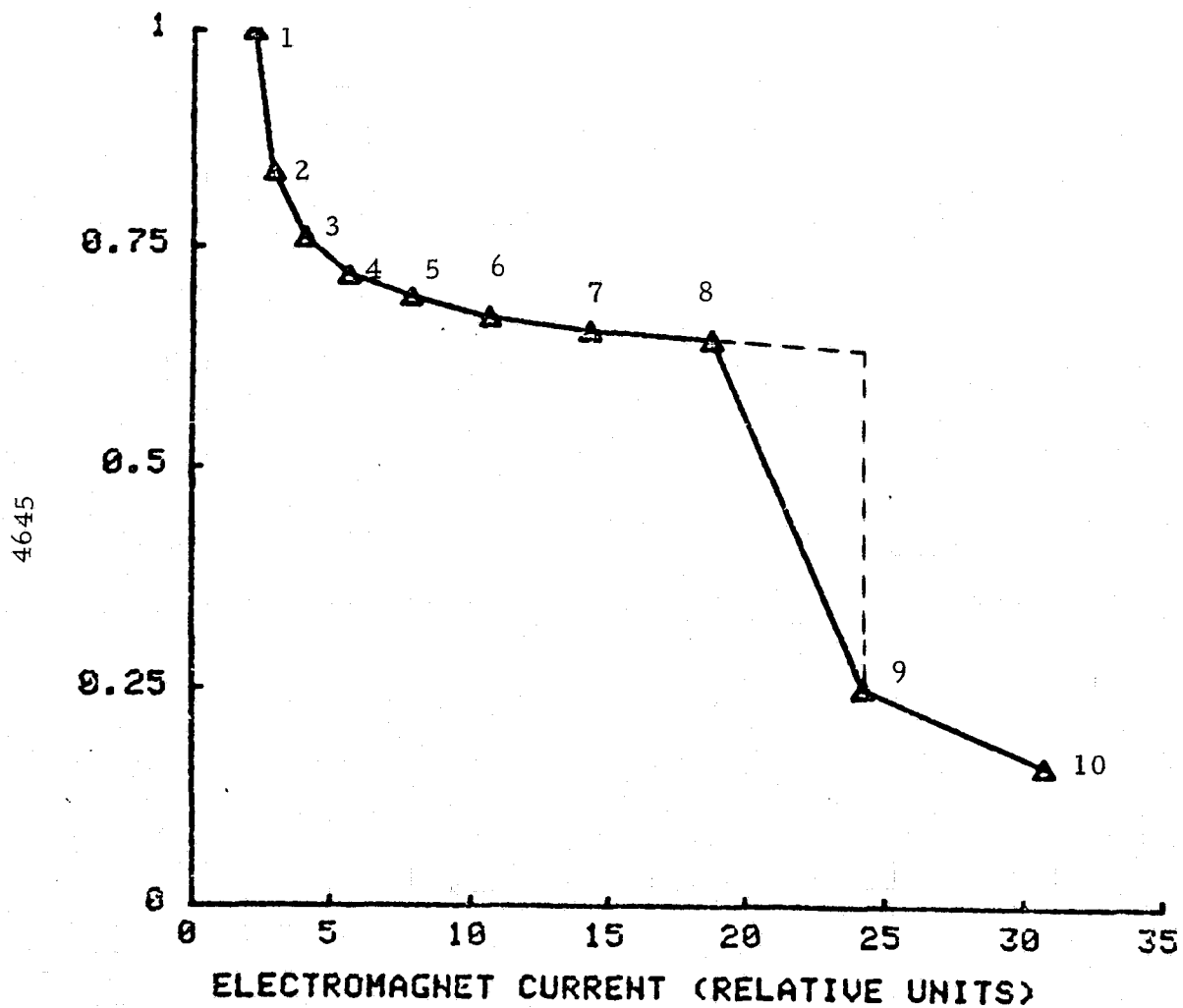

FIGURE 30. GRAPH SIMILAR TO FIGURES 27, 28, AND 29 BUT WITH THE COAL-ROCK INTERFACE AT 9 INCHES.

4788

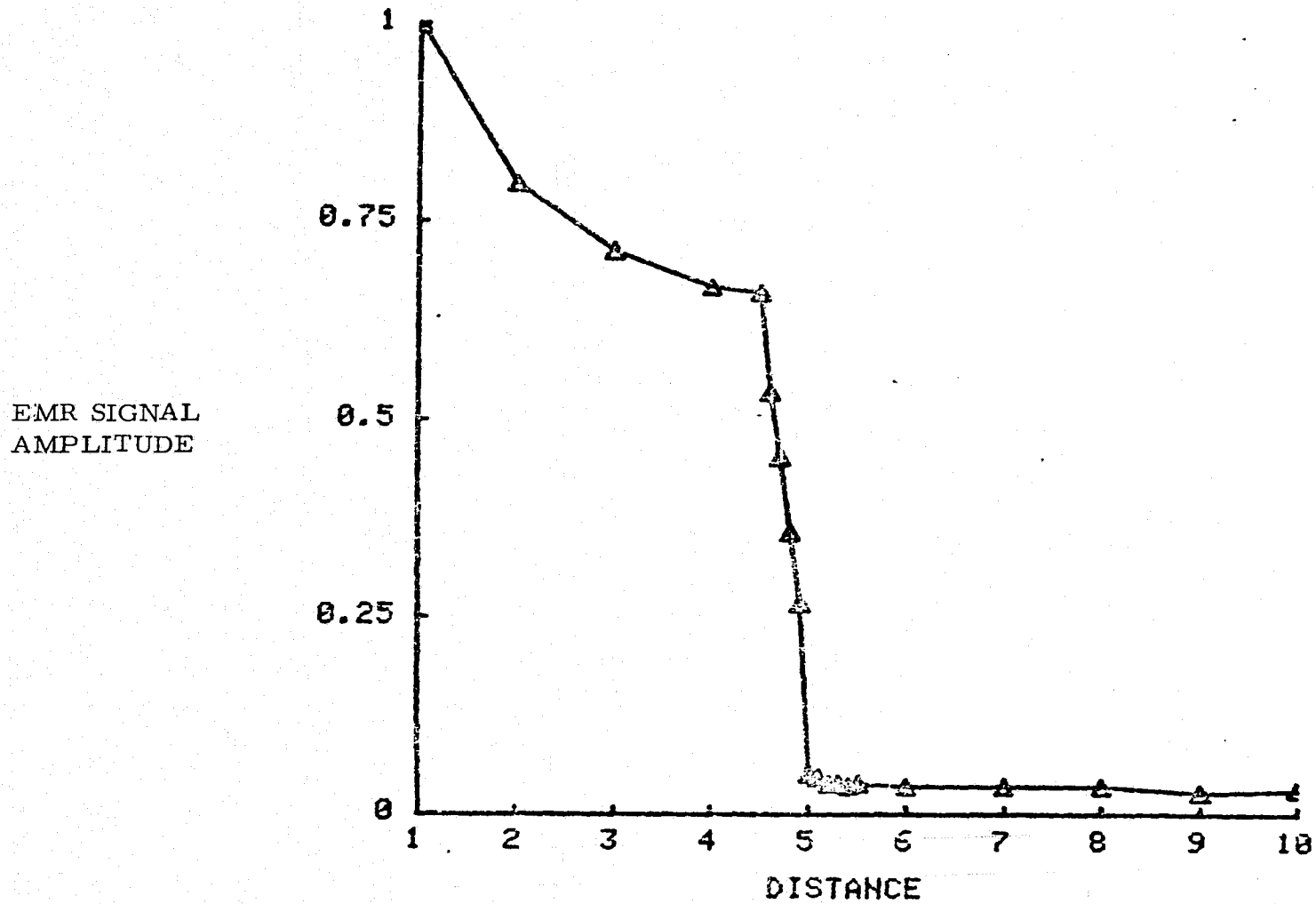

FIGURE 31. GRAPH OF THE EMR SIGNAL AMPLITUDE FROM THE MATHEMATICAL MODEL AS A FUNCTION OF DISTANCE WITH A COAL-ROCK INTERFACE AT 5 INCHES. Additional points are taken every 0.1 inch from 4.5 to 5.5 inches.

the interface is placed at 10 inches, the graph of Figure 32 is obtained. The additional points in this case were from 9.5 to 10.5. Again the total change takes place in one-half inch.

The magnitude of the changes in the EMR signal amplitude caused by the abrupt interface (relative amplitude unity to zero) varies with the distance to the interface. The change values at various distances are:

- . change at 2 inches = 95 to 5
- . change at 5 inches = 72 to 10 and 65 to 5
- . change at 9 inches = 65 to 20
- . change at 10 inches = 62 to 10

With no interface, the signal level changed rapidly from 100 at one inch to 72 at five inches. The level change from five inches to ten inches was only from 72 to 62. It appears from the model chosen that the signal level reaches an asymptotic value of around 60.

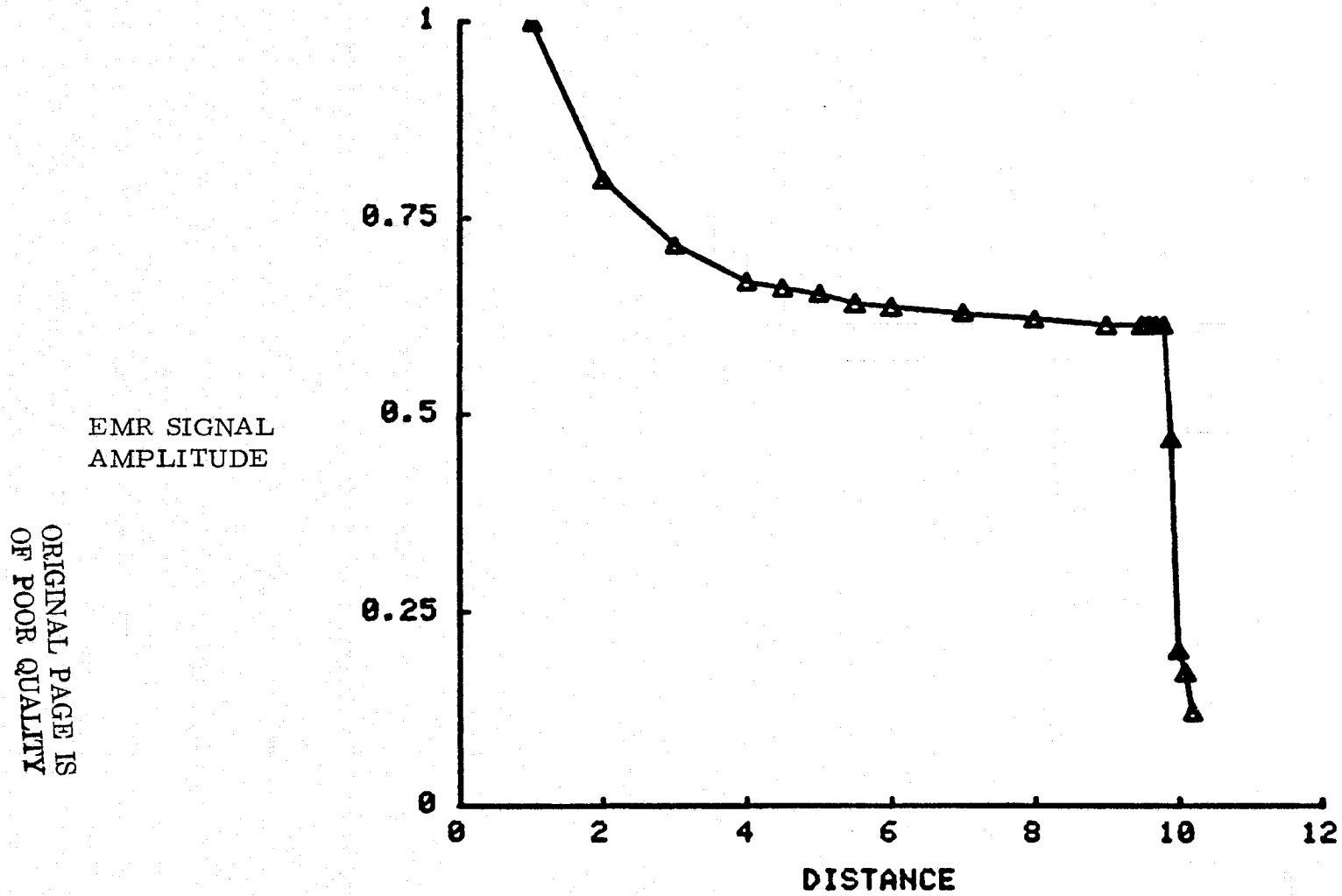

FIGURE 32. GRAPH OF THE EMR SIGNAL AMPLITUDE FROM THE MATHEMATICAL MODEL AS A FUNCTION OF DISTANCE WITH A COAL-ROCK INTERFACE AT 10 INCHES. Additional points every 0.1 inch from 9.5 to 10.5.

IV. CONCLUSIONS AND RECOMMENDATIONS

A. Conclusions

To make conclusions it may first be helpful to summarize the results obtained. The EMR signal levels and coal-rock ratios across the five positions on the four interfaces of the Drummond Strip Mine are given in Table I. The results from position 3, interface 3, showed that there was either: (1) a diffuse interface, (2) a change in coal quality across the interface, or (3) two interfaces. If two interfaces are present around interface 3 then the first one has a coal/rock EMR ratio of 85/40 at 10 inches into the coal; the second interface could be at 6 inches into the rock and have an EMR coal/rock ratio of 40/5.

Table I.

EMR Signal Levels and Ratios - Drummond Strip Mine

<u>Place</u>	<u>Signal in Coal</u>	<u>Signal in Rock</u>	<u>Coal/Rock Ratio</u>
First one-half inch Position 1, Interface 1	96	37	2.6
Average Position 1, Interface 1	85.3	13.2	6.48
First one-half inch Position 5, Interface 1	68	4.5	15
Average Position 5, Interface 1	69.1	5.9	11.7
First one-half inch Position 2, Interface 2	58	6.0	9.67
First one-half inch Position 4, Interface 4	41	7.5	5.47

The average EMR signal levels and coal/rock ratios across the interfaces in the Bruceton mine are: wild-coal/rock = $46/13 = 3.54$ and coal/rock = $69/13 = 5.3$.

The analyses made on the data from the Drummond Strip Mine samples showed that 70% of the EMR signals from the rock had levels below 15 units and that 59% of the signals from rock were below 10 units. There appeared to be two groupings of the signal levels from the Drummond coal. The lower grouping was from 55 to 70 units and contained 41% of the samples. The upper grouping involved 37% of the samples in the range of from 75 to 90 units.

The EMR signals from interface 2, position 2 from the Drummond Strip Mine had an average value of 85 from 13 inches into the coal to 5 inches into the coal. From 5 inches into the coal to the coal/rock interface, the EMR coal signals averaged only 60. Does this significant EMR signal change indicate a change in coal quality close to (within 5 inches) the coal/rock interface?

The laboratory EMR spectrometer performed very well and permitted a measurement of 135.6 for the signal/noise ratio of coal EMR signals at 154.5 MHz. The signal/noise ratio measured is not the maximum which can be obtained and values between 800 and 1100 are practical for consideration when the detection head is flush against the surface of a thick vein of coal.

The results computed from the mathematical model show that a very useful change in the EMR signal is caused by the interface assumed from the measurements on the coal and rock samples. The EMR signal change should be from 95 to 15 when the interface is at 2 inches, 72 to 15 at 5 inches, 65 to 15 at 9 inches and 62 to 15 at 10 inches. In addition, the changes take place over the very short length of one-half inch.

In general, it can be concluded that, with the proper implementation, it is feasible to use EMR signals to determine the distance from the detection head to both air/coal and coal/rock interfaces. The signals from an EMR detection head should provide a more than adequate change when the "sensitive" region is scanned past an air/coal or a coal/rock interface since the differences between the EMR signals from coal samples and samples of air or rock are many times larger than the noise. The results from the mathematical analyses indicate an excellent probability of achieving an EMR Coal Thickness Gauge with a resolution of 1 centimeter or less over a thickness range of from 1.3 cm (1/2 inch) to 15 cm (6 inches). There is also an excellent probability of constructing a detection head with its associated electronics which can meet the size, weight, power and environmental requirements of a coal thickness gauge for use on mine machinery. From the results and analyses, it is possible to describe one concept of the use of EMR signals to determine the distances to air/coal and coal/rock interfaces. For this one concept the EMR equipment will generate a signal whose amplitude is proportional to the density

of free electrons in a thin "sensitive" volume located at a voltage-controllable distance measured from the detection head into the coal or rock. The amplitude of the EMR signal as a function of the control voltage for the position of the "sensitive" volume will define the distance to the coal/rock interface from the detection head. As the "sensitive" volume is moved through the coal-to-rock interface by varying the controllable voltage, the EMR signal will decrease from a high level in the coal (a high density of free electrons), to a low level in the rock (a low density of free electrons). The position equivalent to the control voltage at which the signal decreases by one-half the coal-to-rock signal difference is the distance to the coal/rock interface. In a similar manner, the air-to-coal interface can be located as a signal increase. The width of the "sensitive" volume, along the direction of variation, is around 0.5 inch. However, the accuracy of location is less than the 0.5 inch width, and depends upon the signal-to-noise ratios of the signals and the differences in the EMR signal levels from the coal, rock and air.

B. Recommendations

The results obtained in the foregoing study establish the basic feasibility of using EMR as the basis for a coal thickness gauge. It is recommended that the technique be further developed to permit experimental verification of the range and accuracy capabilities and to determine other important performance characteristics and limitations.

APPENDIX A

BIBLIOGRAPHY

BIBLIOGRAPHY

1. "Slurry: A Fight Over Best Way to Haul Coal", U. S. News & World Report, March 29, 1976.
2. Lytle, R. J. and Lager, D. L., "Using the Natural-Frequency Concept in Remote Probing of the Earth", Lawrence Livermore Laboratory, UCRL-77022 Rev. 1, November 13, 1975.
3. Lytle, R. Jeffrey and Lager, Darrell L., "Theory Relating to Remote Electromagnetic Probing of a Nonuniform-Thickness Coal Seam", Lawrence Livermore Laboratory, UCRL-77014 Rev. 1, November 13, 1975.
4. Aude, T. C., Thompson, T. L. and Wasp, E. J., "Slurry-Pipeline Systems for Coal, Other Solids Come of Age", The Oil and Gas Journal, July 21, 1975, P. 66.
6. Durham, G. H., "Long-Distance Slurry Lines Have Great Future", P&GJ, April, 1975, P. 28.
7. Gat, Uri, Dhir, V.K. and Crewe, G. F., "Effect of Pumping on the Caking Properties of Coal", CIM Bulletin, December, 1974, P. 71.
8. Ferretti, Emmett J., "Feeding Coal to Pressurized Systems", Chem. Eng., December 9, 1974, P. 113.
9. "Coal-Slurry Pipelines... A Rapidly Growing Technique", Coal Age, July 1974, P. 96.
10. Kini, Kulai A. and Murthy, Gumma S., "Binding Properties of Coal-Tar Pitches in Relation to Nuclear Magnetic Resonance Spectra", Fuel, Vol. 53, No. 3, July 1974, P. 204.
11. Wasp, E. J. and Thomspson, T. L., "Coal Slurry Pipe Lines - Energy Movers of the Future", Pipe Line Industry, May 1974, p. 26.
12. "ETSI Proposes 1,000-mile, Wyoming-Arkansas Slurry Line", Pipe Line Industry, May 1974, p. 65.
13. Montfort, J. G., "Black Mesa System Proves Coal Slurry Technology", Pipe Line Industry, May 1974.
14. "Wyoming-To-Arkansas Coal Slurry Line Planned", P&GJ, May, 1974, p. 18.

15. "800-Mile Coal Pipeline Proposed for Northwest", ENR, May 30, 1974, p. 10.
16. Letters to the Editor: Pearson, Robert M., "Chemical Structure of Pitch by Proton Nuclear Magnetic Resonance"; Bozkurt, Bedri, Gaines, Alec F., et. al., "Oxidation of Solid Fuels by Alkaline Nitrobenzene"; Moschopedis, Speros E. and Speight, James G., "Oxidation of Petroleum Fractions", Fuel, Vol. 52, No. 1, January, 1973, p. 80-83.
17. Hall, A. W., Konchesky, J. L., and Stewart, R. F., "Continuous Monitoring of Coal by a Neutron Moisture Meter", Bureau of Mines, RI 7807, 1973.
18. Yulish, Judith, "Solids Pipelining Pushes On", Chem. Eng., September 6, 1971, p. 32.
19. Roberts, R. N., "Pipelines for Process Slurries", Chem. Eng., July 31, 1967, p. 125.
20. Friedel, R. A. and Retcofsky, H. L., "Quantitative Application of C^{13} Nuclear Magnetic Resonance: C^{13} N.M.R. Signals in Coal Derivatives and Petroleum", Chem. & Ind., March 12, 1966, p. 455.
21. Steelink, Cornelius, "Electron Paramagnetic Resonance Studies of Humic Acid and Related Model Compounds", Coal Science, American Conf. on Coal Science, June 23-26, 1964, p. 80.
22. Austen, D. E. G., Ingram, D. J. E., et. al., "Electron Spin Resonance Study of Pure Macerals", Coal Science, American Conf. on Coal Science, June 23-26, 1964, p. 344.
23. Retcofsky, H. L. and Friedel, R. A., "Proton and Carbon-13 NMR of Coal Derivatives and Other Carbonaceous Materials", Coal Science, American Conf. on Coal Science, June 23-26, 1964, p. 503.
24. Dryden, I. G. C., "Carbon-Hydrogen Groupings in the Coal Molecule", Fuel, Vol. 41, 1962, p. 55.
25. Sanada, Y. and Honda, H., "Molecular Motion and Arrangement in Coal by Nuclear Magnetic Resonance Method", Fuel, Vol. 41, 1962, p. 437.
26. Costantini, Ralph, "Pipelines Show Good Potential for Long-Distance Transporting of Solids", Mining Eng., August 1961, p. 977.
27. Friedel, R. A. and Retcofsky, H., "Spectral Studies of Coal", Proc. of the Conf. on Carbon, Vol. 2, 1961, p. 149.

28. Mangiaracina, R. and Mrozowski, S., "Trapped Radicals in Organic Deposits", Proc. of the Conf. on Carbon, Vol. 2, 1961, p. 89.
29. Jacobowicz, M. and Uebersfeld, J., "Double Magnetic Resonance in Chars", Proc. of the Conf. on Carbon, Vol. 2, 1961, p. 73.
30. Wolfs, P. M. J., Van Krevelen, D. W. and Waterman, H. I., "Chemical Structure and Properties of Coal XXV - The Carbonization of Coal Models", Fuel, Vol. 39, 1960, p. 25.
31. Uebersfeld, J. and Jacobowicz, M., "Double Magnetic Resonance of Fluids Absorbed on Coals", Proc. of the Conf. on Carbon, 1959, p. 267.
32. McCartney, J. T. and Ergun, S., "Optical Properties of Graphite and Coal", Proc. of the Conf. on Carbon, 1957, p. 223.
33. Uebersfeld, J., "These Paris", Annal. Phys., Vol. 13, No. 1, 1956, p. 395.
34. Hennig, G. R., Smaller, B. and Yasaitis, E. L., "Paramagnetic Resonance Absorption in Graphite", Phys. Rev., Vol. 95, 1956, p. 1088.
35. Castle, J. G., Jr., "Paramagnetic Resonance Absorption in a Soft Carbon", Phys. Rev., Vol 95, 1954, p. 846.
36. Castle, J. G., Jr., "Paramagnetic Resonance Absorption in Carbons", Phys. Rev., Vol 94, No. 4, May 15, 1954, p. 1410.
37. Bennett, J. E., Ingram, D. J. E., and Tapley, J. G., "Paramagnetic Resonance in Different Forms of Carbon", Defects in Crystalline Solids, Bristol Conference, 1954, p. 65.
38. Castle, J. G., Jr., "Paramagnetic Resonance Absorption in Graphite", Phys. Rev., Vol. 92, 1953, p. 1063.
39. Babu, S. P., "Trace Elements in Fuel," Advances in Chemistry, Series 141, American Chemical Society, Washington, D. C. (1975) pp. 1-22.
40. Lee, B. S., "Slurry Feeding of Coal Gasifiers," Chem. Eng. Prog., Vol. 71, #4 (April 1975), p. 139.
41. Parkhomenko, E. I., "Electrical Properties of Rocks," Plenum (1967), p. 43, 44.

42. Trendade, S. C. and Kolm, H. H. , "Magnetic Desulfurization of Coal," IEEE Transactions on Magnetics, Vol. MAG-9, No. 3 (Sept. 1973), p. 310.
43. Ladner, W. R. and Stacey, A. E. , "The Analysis of the Lineshapes of the Hydrogen Magnetic Resonance Spectra of Coals in Terms of the Lineshapes of Known Structures," Fuel, Vol. 43 (1964), p. 13.
44. Ladner, W. R. and Stacey, A. E. , "Broadline Nuclear Magnetic Resonance Measurements on Carbonized Coals," Fuel, Vol. 44 (1965), p. 71.
45. Ubersfeld, U. , Etienne, A. , and Combrisson, J. , "Paramagnetic Resonance, A New Property of Coal-Like Materials," Nature, Vol. 174 (25 Sept. 1954), p. 614.
46. Ingram, D. J. E. and Colegues, "Paramagnetic Resonance in Carbonaceous Solids," Nature, Vol. 174 (23 Oct. 1954), p. 797.
47. Ingram, D. J. E. , and Bennett, J. E. , Phil. Mag. Vol. 45 (1954), p. 545.
48. Singer, L. S. , "A Review of Electron Spin Resonance in Carbonaceous Materials," Proc. of the Conf. on Carbon, Vol. 2 (1961), p. 37.
49. Bennett, J. E. , et. al. , "Paramagnetic Resonance from Broken Carbon Bonds," J. Chem. Phys., Vol. 23 (1955), p. 215.
50. Ingram, D. J. E. , "Electron Resonance Studies of Heat-Treated Organic Compounds," Proceedings of the Conference on Carbon (3rd Biennial) (1957), p. 93.
51. Ubersfeld, U. and Erb. , E. , "Paramagnetic Resonance in Coals and Heat Treated Organic Compounds," Proc. of the Conference on Carbon (1957), p. 103.
52. Rollwitz, William L. , "NMR Fundamentals," Southwest Research Institute, San Antonio, Texas, Sept. 1965.
53. Retcofsky, H. L. and Friedel, R. A. , "Room-Temperature Proton Magnetic Relaxation Times in a Bituminous Coal," Fuel, Vol. SL VII, No. 5 (Sept. 1968), p. 391.
54. Wart, J. R. and Chang, D. C. , "Theory of Electromagnetic Scattering from a Layered Medium with a Laterally Varying Substrate," Radio Science Vol. 11, No. 3, (March 1976), pp. 221-229.

55. Cook, J. C. , "R. F. Electrical Properties of Bituminous Coal Samples," Geophys. , Vol. 35, pp. 1079-1085, 1970.
56. Cook, J. C. , "Radar Transparencies of Mine and Tunnel Rocks," Geophys. Vol. 40, No. 5, pp. 865-885, Oct. 1975.
57. Suhler, S. A. , Owen, T. E. , et. al. , "Development of a Deep Penetrating Borehole Geophysical Technique for Predicting Hazards Ahead of Coal Mining," Phase I, Interim Report, Contract No. H0252033, U. S. Bureau of Mines, Sept. 1975.
58. Suhler, S. A. , Owen, T. E. , and Claassen, J. P. , "Development of an Advanced Prototype VHF Tunnel Detector (U)," Final Technical Report 14-2694, Southwest Research Institute, Contract DAAK02-70-C-0101, USAMERDC, July 1970 (Confidential).
29. Fountain, L. S. , Hipp, J. E. , and Owen, T. E. , "Study and Analysis of Soil Anomalies Related to Mine Detection," Final Technical Report 1402885, Southwest Research Institute, Contract DAAK02-70-C00586, May 1971 (Confidential).
60. Cook, J. C. , "A Study of Radar Exploration of Coalbeds," Tech. Report, TR-71-8 Bureau of Mines-OFR-5-72, Contract H0101620, June 1971.
61. Moffatt, D. L. , "Electromagnetic Pulse Sounding for Geological Surveying with Application in Rock Mechanics and Rapid Excavation Program," Report 3190-1, OSUEL, Contract H0210042, U. S. Bureau of Mines and ARPA, Oct. 1971.
62. Holser, W. T. , Brown, R. J. S. , Roberts, F. A. , Frederikson, D. A. , and Unterberger, "Radar Logging of a Salt Dome," Geophys. , Vol. 37, No. 5, pp. 889-906, Oct. 1972.
63. Morey, R. M. and Harrington, W. S. , "Feasibility Study of Electromagnetic Subsurface Profiling," EPA-R2-72-082, Contract 68-01-0062, EPA, Oct. 1972.
64. Hipp, J. E. , "Soil Electromagnetic Parameters as Functions of Frequency, Soil Density and Soil Moisture," Proc. IEEE, Jan. 1974.
65. Hipp, J. E. and Fountain, L. S. , "In Situ Soil Properties Measurement: Instrumentation, Theory and Method," Final Technical Report, Vol. III-14-3440, Southwest Research Institute, Contract DAAK02-72-C-0638, June 1974.
66. Dolphin, L. , Bollen, R. and Ortzal, G. , "An Underground Electromagnetic Sounder Experiment," Geophys. , 1974.

67. Gates, D. C. and Armistead, R. A. , "The Use of Advanced Technologies for Locating Underground Obstacles," Southwest Research Institute Project PYU-2660, Contract 14-01-0001-01570, U. S. Dept. of Interior and Elect. Power Res. Inst. , June 1974.
68. Scott, J. H. and Tibbetts, B. L. , "Well Logging Techniques for Mineral Deposit Evaluation: A Review," U. S. Bureau of Mines Info. Circ. IC-86-27, 44 pp. , 1974.
69. Day, J. G. , "Cave Detection by Geoelectrical Methods; Part II: Transient and Inductive Methods," Cave Notes, Vol. 7, No. 3, 1965.
70. Bristow, C. , "A New Graphical Resistivity Technique for Detecting Air-Filled Cavities," Studies in Speleology, 1, Part 4, 204-227, December 1966.
71. Fountain, L. S. , "An Exploratory Study of Soil Resistivity Measurements Using a Rolling Contact Electrode Array," Final Technical Report, SwRI Internal Research Project 14-9057, April 1972.
72. Fountain, L. S. , Herzig, F. X. , and Owen, T. E. , "Detection of Subsurface Cavities by Surface Remote Sensing Techniques," FHWA Report No. FHWA-RD-75-80, Southwest Research Institute Project 14-4013, June 1975.
73. Chan, S. H. , "A Study of the Direct Interpretation of Resistivity Sounding Data Measured by Wenner Electrode Configuration," Geophys. Prospect 18 (2), 215-235, June 1970.
74. Lee, T. , "A General Technique for the Direct Interpretation of Resistivity Data Over Two-Dimensional Structures," Geophys. Prospect. (Netherlands), 20 (4), 847-859, December 1972.
75. Bates, E. R. , "Detection of Subsurface Cavities," Miscellaneous Paper S-73-40, AD 762538, U. S. Army Engineer Waterways Experiment Station, Vicksburg, Mississippi, June 1973.

76. Greene, Frank M., "The Near-Zone Magnetic Field of a Small Circular-Loop Antenna," J. of Res. of NBS-C., Vol. 71C, No. 4, October-December 1967, pp. 319-326.
77. Grant, W. J. C., and Strandberg, M. W. P., "Magnetic Field of Noncylindrical Coils," Rev. of Sci. Instr., Vol. 36, No. 3, March 1965, pp. 343-346.
78. Alldred, J. C. and Scollar, I., "Square Cross Section Coils for the Production of Uniform Magnetic Fields," J. Sci. Instrum. Vol. 44, 1967, pp. 755-760.
79. Gabillard, MM. Robert, and Martin, Jacques-Andre, presentee par Cabannes, M. Jean., "Resonance Paramagnetique Electronique - Mesure des temps de relaxation T_1 et T_2 du radical libre diphenyl-picryl-hydrazil," Comptes Rendus, Seance du 14 Juin 1954, pp. 2307-2309.
80. Roest, R. and Poulis, N. J., "The Spin-Spin Relaxation Time of Diphenyl Picryl Hydrazyl in Weak Fields," Physica 25, pp. 1253-1254, Com. No. 319b from Kamerlingh Onnes Laboratorium, Leiden, Nederland.
81. Narasimhan, P. T., "NMR, ESR & NQR & Theoretical Chemistry," J. Scient. Ind. Res., Vol. 35, January 1976, pp. 11-18.
82. Poulis, N. J., "Nuclear Magnetic Relaxation in Metallic Lithium and Aluminium," Physica XVI, No. 4, April 1950, pp. 373-376.
83. Mansfield, P. and Ware, D., "Artificial Line Narrowing and Spin-Lattice Relaxation in Solids," 14th Colloque Ampere - 1966, "Magnetic Resonance & Relaxation," Ed. by R. Blinc, North Holland, 1967, pp. 948-951.
84. Powles, J. G. and Mansfield, P., "Double-Pulse Nuclear-Resonance Transients in Solids," Physics Letters, Vol. 2, No. 2, 15 Aug. 1962, pp. 58-59.
85. Mansfield, P. and Ware, D., "Nuclear Resonance Line Narrowing in Solids by Repeated Short Pulse RF Irradiation," Physics Letters, Vol. 22, No. 2, 1 August 1966, pp. 133-135.
86. Clough, S., "Nuclear Magnetic Resonance Line Shapes in Solids," 13th Colloque Ampere - 1964, "Nuclear Magnetic Resonance & Relaxation in Solids," Ed. by L. Van Gerven, North-Holland, 1965, pp. 95-98.

87. Mansfield, P. and Ware, D., "Nuclear Double Resonance Effects of Multiple Solid Echo Trains," *Physics Letters*, Vol. 23, No. 7, 14 November 1966 pp. 421-422.
88. Hausser, R. and Siegle, G., "Free Induction NMR-Signals in Solids," *Physics Letters*, Vol. 19, No. 5, 15 November 1965, pp. 356-358.
89. Ernst, H., Fenzke, D., Heink, W., Pfeifer, H. and Schmiedel, H., "A Simple Method to Measure NMR Shifts in Solids: Sweepled Multiple Pulse Sequence Experiments," 17th Colloque Ampere - 1972, ed. by V. Hovi, North-Holland - 1973, pp. 384-386.
90. Mansfield, P., "Multiple-Pulse Nuclear Magnetic Resonance Transients in Solids," *Phy. Rev.* Vol. 137, No. 3A, 1 Feb., 1965, pp. A961-A974.
91. Mansfield, P. and Ware, D., "Nuclear Resonance Line Narrowing in Solids by Repeated Short Pulse R.F. Irradiation," *Phy. Ltrs.*, Vol. 22, No. 2, 1 August 1966, pp 133-135.
92. Powles, J. G. and Strange, J. H., "Zero Time Resolution Nuclear Magnetic Resonance Transients in Solids," *Proc. Phys. Soc.*, 1963, Vol. 82, pp. 6-15.
93. Owston, "Magnetic Flux Leakage Technique of NDT," *British J. of NDT*, Nov. 1974, pp. 167-168.
94. Herve, J. and Pescia, J., "Le Probleme de la Mesure Des Temps de Relaxation Tres Courts," 12th Colloque Ampere - 1963, "Electronic Magnetic Resonance & Solid Dielectrics," Ed. by R. Servant and A. Charru, North-Holland, 1964.
95. Accou, J. Van Hecke, P., and Van Gerven, L., "Magnetic Dispersion in Weak Steady and Strong HF Fields," 17th Colloque Ampere - 1972, Ed. by Hovi, North-Holland 1973, pp. 379-383.
96. Van Gerven, L., and Van Itterbeek, A., "Sur la forme generale des raies d'absorption paramagnetique dans des champs transversaux (champ HF faible)," 10th Colloque Ampere, "Spectroscopy & Relaxation at Radiofrequencies," 1962., North Holland.
97. Tanaka, Kunio, Yamada, Yoshifumi, Shimizu, Tetsuya, Sano, Fumio and Abe, Zemon, "Fundamental Investigations (in vitro) for a Non-Invasive Method of Tumor Detection by Nuclear Magnetic Resonance," *Biotelemetry* 1: 337-350 (1974).

98. Tanaka, Kunio, Sano, Fumio and Abe, Zenuemon, "Non-Invasive Measurements of Biological Information Utilizing Nuclear Magnetic Resonance Technique - Fundamental Investigations on the Measuring Sensitivity," The Research Institute of Applied Electricity, Hokkaido Univ., Sapporo, Japan.
99. Sasai, Hitoshi and Fukuda, Toyoho, "Consideration of Linear Delay-Differential Systems by Approximation Systems," Faculty of Business Administration, Yokohama National University, Yokohama, Japan.
100. Llaurado, J. G., Sances, Jr., A., and Battocletti, J. H., "Biologic and Clinical Effects of Low-Frequency Magnetic and Electric Fields," ISBN 0-398-03024-3, Lib. of Congress Catalog Card No. 73-18332.
101. Krishnan, R. S., "Nuclear Resonance in Flowing Liquids," Proc. of the Indian Academy of Sciences, Vol. XXXIII, Sec. A, Bangalore City, 1951, pp. 107-111.
102. Bowman, R. L. and Kudravcev, V., "Blood Flowmeter Utilizing Nuclear Magnetic Resonance," IRE Trans. on Medical Electronics, 1959, pp. 267-269.
103. Singer, J. R., "Blood Flow Rates by Nuclear Magnetic Resonance Measurements," Science, Vol. 130, 11 Dec. 1959, pp. 1652-1653.
104. Singer, J. R., "Flow Rates Using Nuclear or Electron Paramagnetic Resonance Techniques with Applications to Biological and Chemical Processes," J. of App. Phy., Vol. 31, No. 1, January 1960, pp. 125-127.
105. Singer, J. R., "Biological Flow and Process Tracing Using Nuclear and Electron Paramagnetic Resonance," IRE Trans. on Medical Electronics, January 1960, pp. 23-28.
106. Morse, O. C. and Singer, J. R., "Blood Velocity Measurements in Intact Subjects," Science, Vol. 170, 23 Oct. 1970, pp. 440-441.
107. Masaaki, Imai and Kunio, Tanaka, "Theoretical Studies on Blood Flowmeter Utilizing Nuclear Magnetic Resonance Techniques," Bulletin of the Research Institute of Applied Electricity, Hokkaido University, Vol. 23, No. 1, Mar. 1971, pp. 11-29.
108. Jackson, Jasper A. and Langham, Wright H., "Whole-Body NMR Spectrometer," The Review of Scientific Instruments, Vol. 39, No. 4, April 1968, pp. 510-513.

109. Battocletti, J. H., Evans, S. M., Larson, S. J., and Antonich, F. J., "Measurement of Blood Flow by Nuclear Magnetic Resonance Techniques," Proc. Symp. Flow, Pittsburg, 4-2-9, 1971, pp. 1401-1409.
110. Battocletti, Joseph H., et. al., "Analysis of a Nuclear Magnetic Resonance Blood Flowmeter for Pulsatile Flow," IEEE Trans. on Biomedical Engineering, Vol. BME-19, No. 6, Nov. 1972, pp. 403-407.
111. Damadian, Raymond, "Tumor Detection by Nuclear Magnetic Resonance," Science, Vol. 171, 19 March 1971, pp. 1151-1153.
112. Faini, G. and Svelto, O., "Signal-to-Noise Considerations in a Nuclear Magnetometer," Supplemento Al Vol. XXIII, Serie X del Nuovo Cimento, N. 1, 1962, 1° Trimestre, pp. 55-66.
113. Bowers, K. D. and Mims, W. B., "Paramagnetic Relaxation in Nickel Fluosilicate," Phy. Rev., Vol. 115, No. 2, July 15, 1959, pp. 285-295.
114. Giordmaine, J. A., Alsop, L. E., Nash, F. R., and Townes, C. H., "Paramagnetic Relaxation at Very Low Temperatures," Phy. Rev. Vol. 109, No. 2, January 15, 1958, pp. 302-311.
115. Mims, W. B., "Electron Echo Methods in Spin Resonance Spectrometry," Rev. of Sci. Instruments, Vol. 36, No. 10, October 1965, pp. 1472-1479.
116. Bozanic, D. A., Krikorian, K. C., Mergerian, D., and Minarik, R. W. "Electron Spin-Echo Studies of Relaxation Processes in High-Spin Ferrimyoglobin," J. of Chem. Phy., Vol. 50, No. 8, 15 Apr. 1969, pp. 3606-3610.
117. Cowen, J. A., Kaplan, D. E., and Browne, N. E., "Electron Spin Echo Studies of Paramagnetic Systems," J. of Phy. Society of Japan, Vol. 17, Sup. B-1, 1962, pp. 465-468.
118. Knowles, P. F., Marsh, D., Rattle, H. W. E., "Magnetic Resonance of Biomolecules - An Introduction to the Theory and Practice of NMR and ESR in Biological Systems," John Wiley & Sons, Ltd., 1976.
119. Volkov, V. I., Muromtsev, V. I., Pukhov, K. K., and Cheredintsev, V. G., "ESR Investigation of Relaxation of Thermodynamically Inequivalent States in a Solid," Sov. Phys. Solid State, Vol. 19, No. 4, April 1977, pp. 720-721.

120. Giordano, M. , Martinelli, M. , Pardi, L. , and Santucci, S. , "Electron Spin Resonance Spectrometer with a New Wideband Resonator for Aqueous Samples," Rev. Sci. Instrum. , Vol. 47, No. 11, November 1976, pp. 1402-1404.
121. Woods, R. Claude, "Field Spinning Zeeman Modulation in Microwave Spectroscopy with Cosine Distribution Magnets," Rev. of Sci. Instrum. Vol, 44, No. 3, March 1973, pp. 274-281.
122. Herve, J. , Reimann, R. , and Speace R. D. , "Resonance magnetique des protons du DPPH a basse temperature," Colloque de Pise, 1960, pp. 397-401.
123. Reimann, Richard, "La Structure de la Raie de Resonance Magnetique des Protons du DPPH a Basse Temperature," Archives des Sciences, Vol. 14, fase. 1, 1961, pp. 2-85.
124. Ishii, Tadao, "Theory of Electromagnetic Radiation in Amplified Sounds. I," J. of Phy. Society of Japan, Vol. 39, No. 4, Oct. 1975, pp. 976-982.
125. Ishii, Tadao, "Theory of Electromagnetic Radiation in Amplified Sounds. II. Discussion on Acoustically Induced Low Field Radiation," J. of Phy. Society of Japan, Vol. 43, No. 2, Aug. 1977, pp. 505-511.
126. David, C. F. , Jr. , Strandberg, M.W.P. , and Kyhl, R. L. , "Direct Measurement of Electron Spin-Lattice Relaxation Times," Phy. Rev. Vol. 111, No. 5, Sept. 1, 1958, pp. 1268-1272.
127. Mayer, H. C. , McDonald, P. F. , and Donoho, P. L. , "Techniques of Ultrasonic Paramagnetic Resonance," Rev. of Sci. Instrum. , Vol. 39, No. 10, Oct 1968, pp. 1459-1460.
128. Pace, J. H. , Sampson, D. F. , and Thorp, J. S. , "Spin-Lattice Relaxation Times in Ruby at 34.6 kMc/sec," Phy. Rev. Ltrs. , Vol. 4, No. 1, Jan. 1, 1960, pp. 18-19.
129. Collins, S. A. , Kyhl, R. L. and Strandberg, M.W.P. , "Spin-Lattice Relaxation from State of Negative Susceptibility," Phy. Rev. Ltrs. , Vol. 2, No. 3, Feb. 1, 1959, pp. 88-90.
130. Pace, J. H. , Sampson, D. F. , and Thorp, J. S. , "Spin-Lattice Relaxation Times in Ruby at 34.6 Gc/s," Royal Radar Establishment, Malvern, Worcs.

131. McDonald, Perry F., "Ultrasonic Paramagnetic Resonance of U^{4+} in CaF_2 ," Phys. Rev., Vol. 177, No. 2, 10 Jan. 1969, pp. 447-453.
132. McDonald, P. F., Meyer, H. C., and Donoho, P. L., "Frequency Dependence of Ultrasonic Paramagnetic Resonance Absorption in $CaF_2:U^{4+}$," Solid State Comm., Vol. 6, 1968, pp. 367-369.