

NASA Technical Paper 1172

**Water-Vapor Pressure
Control in a Volume**

John J. Scialdone

MARCH 1978

**CONFIDENTIAL
COPY**

NASA

NASA Technical Paper 1172

Water-Vapor Pressure Control in a Volume

John J. Scialdone
*Goddard Space Flight Center
Greenbelt, Maryland*

NASA

National Aeronautics
and Space Administration

**Scientific and Technical
Information Office**

1978

This document makes use of international metric units according to the Systeme International d'Unites (SI). In certain cases, utility requires the retention of other systems of units in addition to the SI units. The conventional units stated in parentheses following the computed SI equivalents are the basis of the measurements and calculations reported.

CONTENTS

	<i>Page</i>
INTRODUCTION	1
ANALYSIS	2
CONCLUSIONS	14
ACKNOWLEDGMENTS	14
REFERENCES	15

WATER-VAPOR PRESSURE CONTROL IN A VOLUME

John J. Scialdone
*Goddard Space Flight Center
Greenbelt, Maryland*

INTRODUCTION

Water adsorption or absorption by critical surfaces may degrade the performance of systems exposed to high humidity. The degradation may result from physical or chemical changes of these surfaces and may involve changes in properties such as optical reflectance. In addition, surfaces may release acquired water vapor when exposed to a lower vapor pressure (e.g., surfaces of a spacecraft in orbit). The released vapor may interfere with measurements of the natural environment or may deposit on surfaces at low temperatures, causing their loss of performance. Water that may cause degrading effects is present as a function of the exposure time and temperature, and partial pressure (pp) that exists during manufacture, testing, assembly, shipment, storage, and launch. In the aerospace industry, these problems are recognized, and the humidity environment is controlled during the various stages. The humidity is limited to prevent water absorption but is not maintained low enough to cause high surface resistivity and electrostatic discharges (Reference 1).

In clean rooms, the humidity and temperatures are controlled by purging flows of approximately 20 volume changes per hour at velocities of about 30 m/min (Reference 1). These flows sweep particulates and other gases from the systems and maintain the desired humidity and temperatures.

In this document, the amount of purging flows is evaluated as a function of its entrance vapor pressure, the partial pressure in the volume, the ambient vapor pressure, and the sources of vapor in the volume. No attempt is made to include heat-transfer effects, ventilation required for personnel, particulate sweep requirements, or permeation of vapor through the walls. The analysis is applicable to shipping containers, storage places, and volumes with very limited personnel traffic. However, it can be used with appropriate engineering judgment for any application by adding infiltration and personnel vapor sources, as recommended in Reference 2.

Expressions for the variation with time of the water pp in a volume that has openings to the outside and that includes vapor sources are obtained as a function of the purging flow. The analysis has been supplemented with experimental tests to estimate the diffusion of ambient

humidity through various openings and to check the calculated results. This analysis can be used to obtain the following:

- Pressure versus time in a volume initially at low water-vapor pressure when no purging is available
- Time needed for obtaining a required pressure with a given purging flow
- Flow needed for maintaining a certain humidity in the volume
- Flow required to prevent water condensation on a surface or the degree of water accretion on a surface given the humidity in the volume

Most important, the evaluation of these parameters may prevent the uneconomical practice of purging with too large a flow (about one volume change per minute) and, correspondingly, eliminate the equally undesirable conditions of extreme dryness in a volume.

ANALYSIS

The relations that express the pp of water (P) as a function of time (t) in a volume (V) having an opening of area (A) leading to the outside at partial pressure (P₀) purged with a volumetric flow (Q at pp, P_u) can be derived as follows:

The vapor mass change in the volume is determined by the difference of the rates of vapor flowing into and out of the volume. For isothermal conditions, this mass balance, expressed in pressure volume units, is

$$V \frac{dP}{dt} = C(P_0 - P) - Q(P - P_u) \quad (1)$$

where C (m³/min) is a diffusion constant for the volumetric flow of ambient vapor through opening A into the volume. The general solution of this equation with a constant k to be determined from the initial conditions is:

$$P = K e^{-\left(\frac{C+Q}{V}\right)t} + \frac{CP_0 + QP_u}{C+Q} \quad (2)$$

which can be verified by substitution into equation 1. The vapor pressure in the volume for the various initial conditions is as follows.

If the volume pressure is $P = P_i$ (i.e., quasi-dry) at $t = 0$, the pressure will change as:

$$P = P_i e^{-\left(\frac{c+Q}{v}\right)t} + \left[\frac{P_0 + \frac{Q}{V} \frac{V}{C} P_u}{1 + \frac{Q}{V} \frac{V}{C}} \right] \left(1 - e^{-\left(\frac{Q+c}{v}\right)t} \right) \quad (3)$$

If the volume pressure is $P = 0$ (completely dry) at $t = 0$, the pressure will change as:

$$P = \left[\frac{P_0 + \frac{Q}{V} \frac{V}{C} P_u}{1 + \frac{Q}{V} \frac{V}{C}} \right] \left(1 - e^{-\left(\frac{Q+c}{v}\right)t} \right) \quad (4)$$

If the pressure is $P = P_0$ (wet as the ambient) at $t = 0$, the pressure changes as:

$$P = P_0 e^{-\left(\frac{Q+c}{v}\right)t} + \left[\frac{P_0 + \frac{Q}{V} \frac{V}{C} P_u}{1 + \frac{Q}{V} \frac{V}{C}} \right] \left(1 - e^{-\left(\frac{Q+c}{v}\right)t} \right) \quad (5)$$

In these expressions, the ratio (Q/V) is the purging volume change per unit time that can be interpreted as the inverse of the time constant ($1/\tau_u = Q/V$) of the purging volume. Similarly, $C/V = 1/\tau_0$ is the inverse of the time constant for the ambient humidity entering the volume through A. The equations show that the equivalent time constant (τ_e) for the volume flow conditions is the reciprocal of the sum of the inverse of the individual contributing time constants; i.e.,

$$\tau_e = \frac{1}{\sum \frac{1}{\tau_i}} = \frac{1}{\frac{1}{\tau_u} + \frac{1}{\tau_0} + \dots} \quad (6)$$

If the equivalent time constant is known, the foregoing equations can be generalized to include additional sources, provided that the conductances G (m^3/min), the corresponding time constants $1/\tau = G/V$, and their pressure (P_i) are known.

The equations evaluated for $t = \infty$ indicate the steady-state pressure (P_s) in the volume and the purging flow (Q/V) required for maintaining that pressure. The same information is obtained from a mass balance of the flow going into and out of the volume at equilibrium. This equilibrium pressure is:

$$P_s = \frac{C/V P_o + Q/V P_u + \sum_n G_{in}/V P_{in}}{C/V + Q/V + \sum_n G_{on}/V} \quad (7)$$

and the purging flow for maintaining P_s is:

$$Q/V = \frac{C/V (P_o - P_s) + (\sum G_{in} P_{in} - \sum G_{on} P_s) 1/V}{(P_s - P_u)} \quad (8)$$

where G_{in} are the conductances of additional sources at P_{in} into the volume, and G_{on} are the conductances for the sinks of vapor leaving the volume at P_s . The conductances (Q and C) are assumed to be the same in either direction of flow. This assumption is justified by the small differences of pressure and temperature between the flow into and out of the volume. Equations 7 and 8 indicate the influence on the internal pressure of the purging flow, infiltrations, and other sources. The effect of the dryness (P_u) of the purging can also be assessed.

An additional source that is important in the contamination and deterioration of surfaces is the vapor from a water or ice surface. The net rate of evaporation from surface A at temperature T_i into the volume where the vapor pressure is P_s and temperature T_s is a function of the air movement over the surface, the diffusion coefficient, and the total pressure over the surface. According to Reference 3, the evaporation at normal conditions of pressure and temperature is probably 10^{-2} to 10^{-3} of the maximum evaporation in vacuum. When compared to the maximum rate, other recommendations and empirical equations (References 2 and 4) show a coefficient of about 10^{-4} . Choosing coefficient $B = 10^{-2}$ would provide a conservative estimate of the evaporation at ambient conditions. The evaporation in vacuum can be determined by considering the rates of evaporation and condensation as follows. According to Reference 5, the flow in units of pressure and volume, W_e , from an orifice, A (m^2), of a gas of molecular mass, M (g/mole), at temperature, T_i (K), and pressure, P (torr), is:

$$W_e = 2172 \sqrt{\frac{T_i}{M}} A P_i \text{ torr} \cdot \text{m}^3/\text{min} \quad (9)$$

If P_i is the vapor pressure of the water vapor at T_i , the equation represents full evaporation into vacuum and is equal to Langmuir's equation. Similarly, vapor at P_s and T_s condenses on A at a rate of $W_c = 2172 \sqrt{T_s/M} A P_s$.

The net evaporation or condensation is the difference of these equations times a coefficient less than one. For evaporation at normal conditions, the coefficient can be the suggested B, so that the net evaporation is:

$$W = G_i P_i - G_o P_s = G_i P_i \left(1 - \frac{P_s}{P_i} \frac{G_o}{G_i} \right) \text{ torr} \cdot \text{m}^3/\text{min} \quad (10)$$

where

$$G_i = 2172 B \sqrt{\frac{T_i}{M}} A \text{ m}^3/\text{min} \quad \text{and} \quad G_o = G_i \sqrt{\frac{T_s}{T_i}}$$

with the same surface area for evaporation and condensation. It can be seen that, for small temperature differences, $G_i \approx G_o$ (i.e., the conductances are the same for vapor flowing into and out of the volume).

Experimental

For applying the foregoing relations, the mass-transfer coefficient of the water vapor through the venting port ($C \text{ m}^3/\text{min}$) must be known. This coefficient is a function of several parameters (Reference 2). An equivalent mass-transfer or infiltration coefficient has been experimentally obtained for different sizes of thin orifices. This coefficient reflects the average conditions of encountered total pressures and temperatures. The evaluation of this parameter was carried out in the Test and Evaluation Laboratory at the Goddard Space Flight Center (GSFC). The ambient conditions in this laboratory are maintained at about 50-percent relative humidity with the temperature at 21 to 22°C (69.8 to 71.6°F) so that the vapor partial pressure is about 10 torr. A 0.91- by 0.91-m (3- by 3-ft) (0.651-m³) stainless-steel vacuum chamber (figure 1) was fitted with a variable exhaust port, a flow-meter for measuring gaseous nitrogen (GN₂) purging flow, and a model 1000 hygrometer (Reference 6) manufactured by Panametric, Inc., located at the center of the volume. The hygrometer consists of a porous oxide layer on an aluminum strip covered with a thin coat of gold. Water molecules absorbed on the oxide change the electrical conductivity of the porous wall. The conductivity is related with a calibration curve to the dew/frost-point temperatures, which, when using saturation pressure tables such as those in Reference 7, can indicate the partial pressures. The instrument had been recalibrated against the Cambridge Model 110 hygrometer and standard-solution dew points before these tests.

The experimental determination of $V/C = \tau_0$ was accomplished by measuring the pp inside the chamber as a function of time when various orifices were used. The chamber was

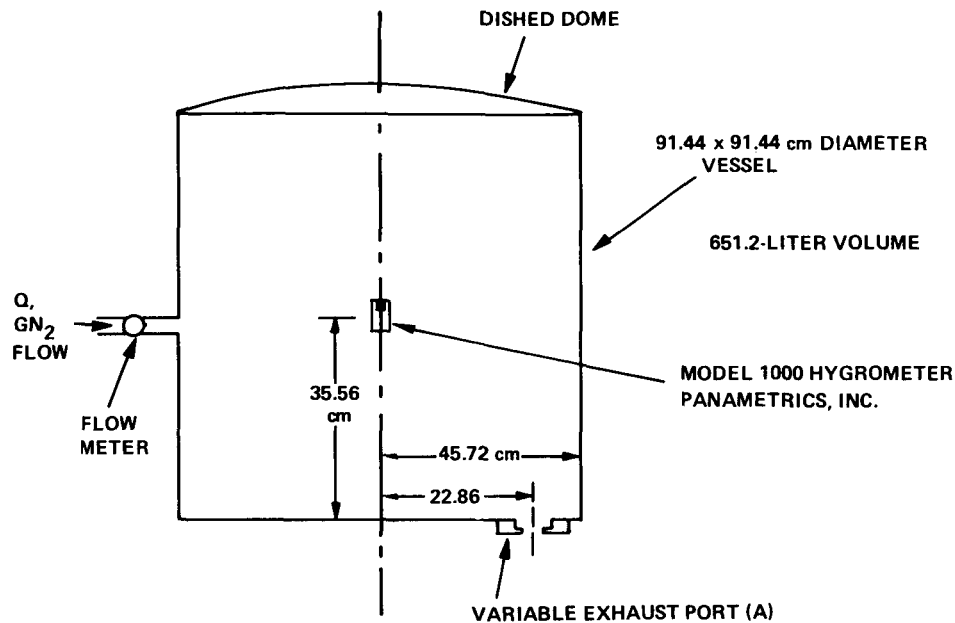

Figure 1. Test setup.

purged with GN_2 to about 10^{-2} torr vapor pressure and then, with no purging, permitted to equilibrate with the ambient pp. Figure 2 shows plots of these tests with the volume to orifice-area ratio (V/A) as a parameter. Equation 4, which is for an initially dry volume ($P = 0$ at $t = 0$) with no purging flow ($Q = 0$), describes the pressure in the volume connected through a conductance (C) to the outside at P_0 ; i.e.,

$$P = P_0 \left(1 - e^{-C/V t} \right) \quad (11)$$

From this equation, the value of t for $P_0 = P(1 - e^{-1}) = 0.63 P_0$ corresponds to the time constant ($\tau_0 = V/C$). Figure 3 is a log plot of the measured time constants versus V/A . The scattered data were plotted by a straight line with a slope of 0.25. It shows that, for a volume/area ratio (V/A) of 10 to 10^6 , the time constant (V/C) varies from about 0.7 to 13 days. A better correlation of the results should be obtained by performing additional tests. As shown in these figures, a result with an opening consisting of an 0.5-inch inside diameter by 18-inch long pipe is also included, although the pipe cannot be considered an orifice with an area given by the pipe internal diameter. Figures 4, 5, and 6 compare experimental results with those calculated by using equation 4 and the V/C of figure 3. In these tests, dry nitrogen flows of 1.88, 0.944, 0.472, and 0.094 l/min, corresponding to a Q/V of 2.9×10^{-3} , 1.45×10^{-3} , 7.25×10^{-4} , and 1.45×10^{-4} changes per minutes, were circulated through the volume. The exhaust orifices for these tests were 1.27-cm diameter (0.5-inch), 5.08-cm diameter (2-inch), and two 10.16-cm diameter (4-inch) parallel combination. The agreement for the calculated and measured results appears to be fairly good. Additional

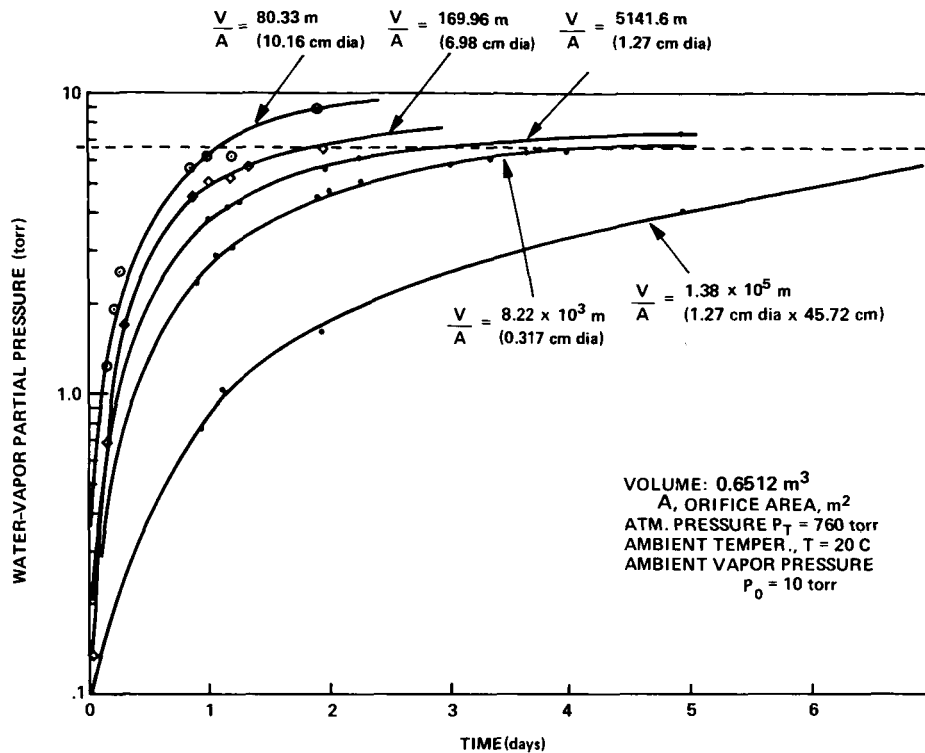

Figure 2. Water-vapor pressure versus time in an initially dry vessel.

tests were performed (figure 7) with the volume initially at ambient partial pressure and subsequently purged with GN_2 flows corresponding to a Q/V of 2.9×10^{-3} , 1.45×10^{-3} , 1.45×10^{-3} , and 7.25×10^{-4} volume changes per minutes. The V/A was 80.3 m, corresponding to a 10.16-cm (4-inch) orifice. The test results differ 1 to 2 torr at the steady-state conditions from those calculated by using equation 5.

The steady-state values of the pressures obtained from these tests have been superimposed on those calculated from the equations evaluated at $t = \infty$ and for $P_u = 0$ (figure 8). This figure shows the steady-state pressure normalized to the ambient pp (P/P_0) versus the purging volume changes per minute (Q/V) with the volume orifice-area ratios (V/A) as the parameter which varies from 1 to 10^6 .

Applications

Initial Purging

The equations show that the time required for obtaining a desired pp is dictated by the equivalent time constant in the exponential functions. This time constant is dominated strongly by the purging flow (Q/V) time constant because, as shown by the tests, the

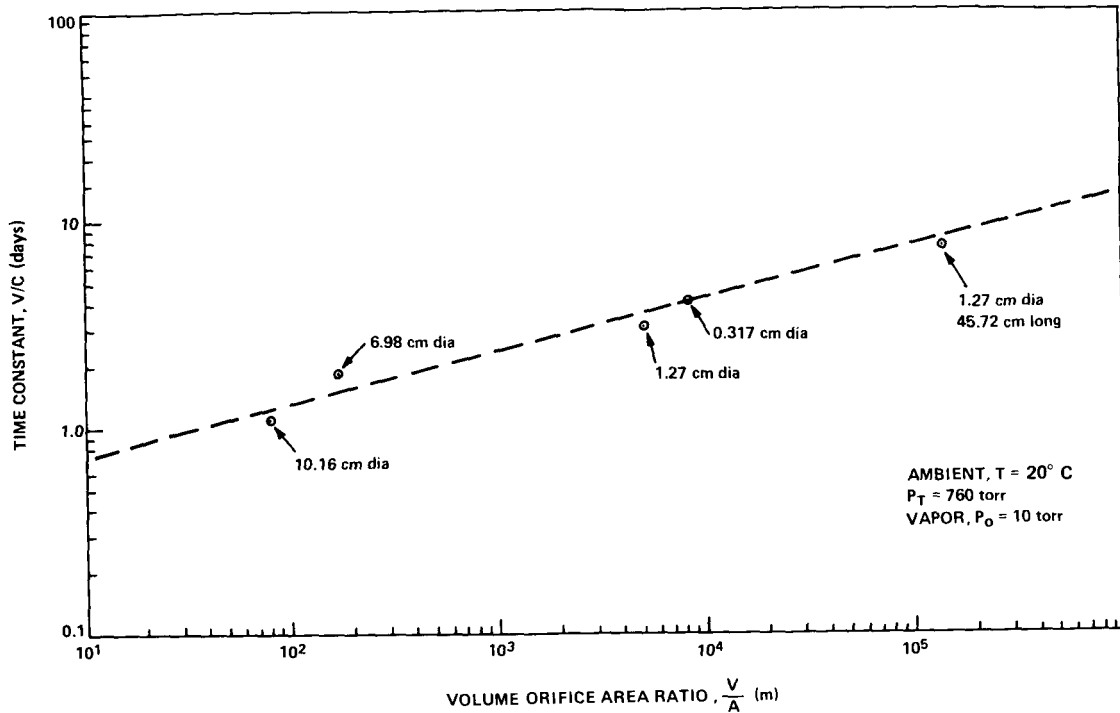

Figure 3. Volume orifice time constant versus volume orifice-area ratio for vapor diffusion.

infiltration time constant (V/C) is on the orders of days. In a reasonable application, the contribution from other sources would also have relatively long time constants, and the purging flow would be large enough to bring about a needed humidity in a reasonable length of time. Therefore, the initial purging flow can be established by letting C/V and other contributing changes per unit time tend to zero. With these substitutions, equation 5 reduces to $P = P_0 \exp(-Q/V t)$, and the initial purging flow is:

$$\frac{Q}{V} = \frac{1}{t} \ln \frac{P_0}{P} \quad \text{min}^{-1} \quad (12)$$

where P_0 is the initial water pp, P is the desired pressure, and t is the length of time needed for accomplishing the pressure change. For example, if a pressure $P = 5\% P_0$ in 3 minutes is desired, the required flow change is one volume per minute.

Steady-State Purging

The initial purging flow can be continued, and this would bring about a dryness in the volume corresponding to that of the purging flow. However, the large flow could be

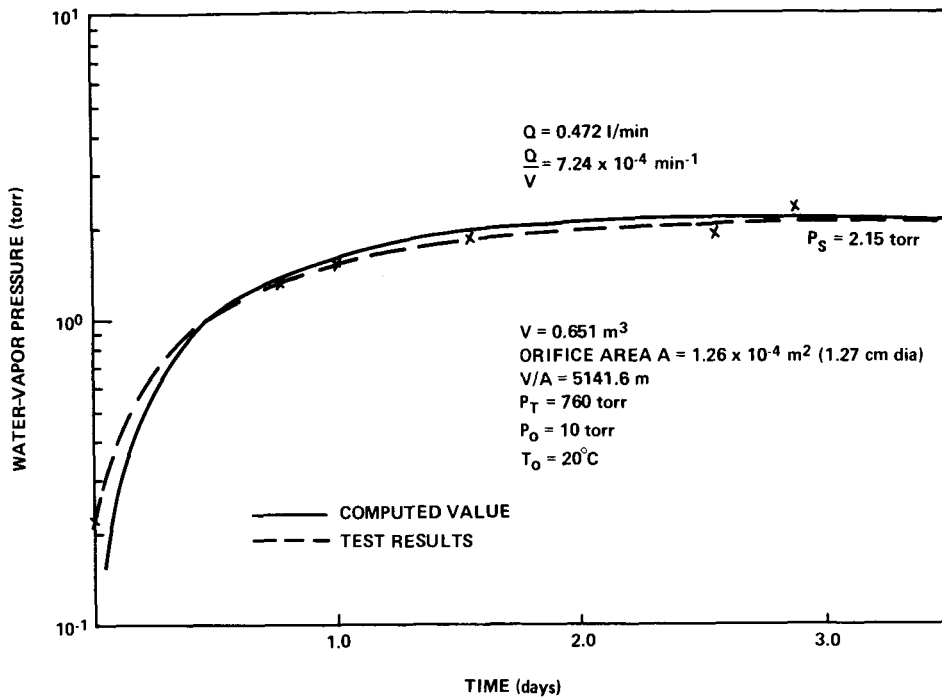

Figure 4. Vapor pressure versus time in an initially dry volume ($V/A = 5141.6$) as a function of GN_2 purging flow.

uneconomical and objectionable because of the high flow velocities in the volume. Also, the ultimate desirable dryness could be obtainable only by changing the dryness of the flow. For GN_2 purging, the ultimate dryness could be controlled only by flow adjustment. As previously indicated, the degree of dryness is important for controlling condensation or evaporation on a critical surface. The required flow can be determined from the steady-state solutions of the equations (equation 8).

As an application of this work, consider the following problems which could be applicable to the shuttle bay volume:

Determine the flow of purging air at $T_u = 25^\circ\text{C}$ with a relative humidity (RH) of $\phi_u = 10\%$ or $\phi_u = 0$ required to attain within 5 minutes and maintain a temperature of $T_s = 25^\circ\text{C}$ and RH $\phi_s = 25\%$ in a volume, $V = 350 \text{ m}^3$, with a venting area of $A = 0.48 \text{ m}^2$. The volume is initially at the ambient conditions of $T_0 = 32.5^\circ\text{C}$ and RH $\phi_0 = 80\%$.

$$V = 350 \text{ m}^3; V/A = 729; \text{ from figure 3, } V/C = 2.2 \text{ d} = 3.168 \times 10^3 \text{ min}$$

$$T_0 = 32.5^\circ\text{C}; \phi_0 = 80\%; \text{ from water-vapor pressure table, } P_{s0} = 36.69 \text{ torr,}$$

$$P_0 = \phi_0 P_{s0} = 29.35 \text{ torr}$$

$$T_u = 25^\circ\text{C}; \phi_u = 10\%; \text{ from water-vapor pressure table, } P_{su} = 23.76 \text{ torr,}$$

$$P_u = \phi_u P_{su} = 2.37 \text{ torr}$$

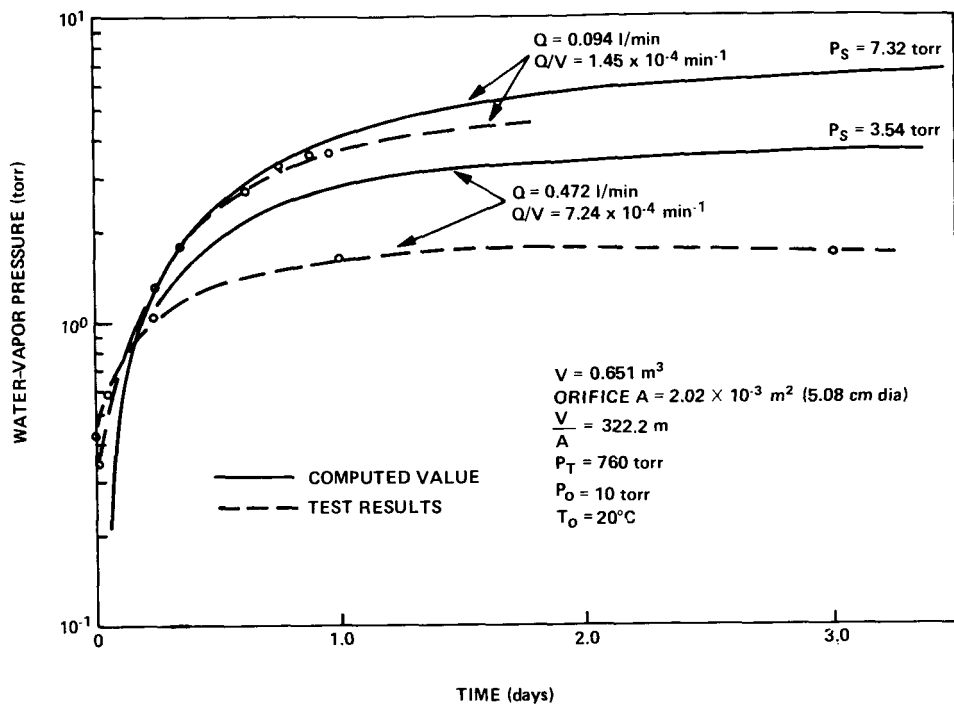

Figure 5. Vapor pressure versus time in an initially dry volume ($V/A = 322.2$) as a function of GN_2 purging flow.

$$T_u = 25^\circ\text{C}; \phi_u = 0; \text{ from water-vapor pressure table, } P_u = 0$$

$$T_s = 25^\circ\text{C}; \phi_s = 25\%; \text{ from water-vapor pressure table, } P_{ss} = 23.76 \text{ torr,}$$

$$P_s = \phi_s P_{ss} = 5.94 \text{ torr}$$

The flow for attaining $P_s = 5.94 \text{ torr}$ in 5 minutes from an initial $P_0 = 29.35$ is derived from equation 12,

$$(Q/V)_i = \frac{1}{t} \ln \frac{P_0}{P_s} = 0.319 \text{ min}^{-1} \text{ so that } Q_i = \left(\frac{Q}{V}\right)_i V = 111 \text{ m}^3/\text{min}$$

If purging is continued with this flow, the volume would attain the RH of the purging flow as verified by equation 7 with $Q/V = 0.319$; i.e.,

$$P_s = \frac{P_0 + \frac{Q}{V} \frac{V}{C} P_u}{1 + \frac{Q}{V} \frac{V}{C}} = 2.39 \text{ torr} \text{ so that } \phi_s = \frac{P_s}{P_{su}} = 10\%$$

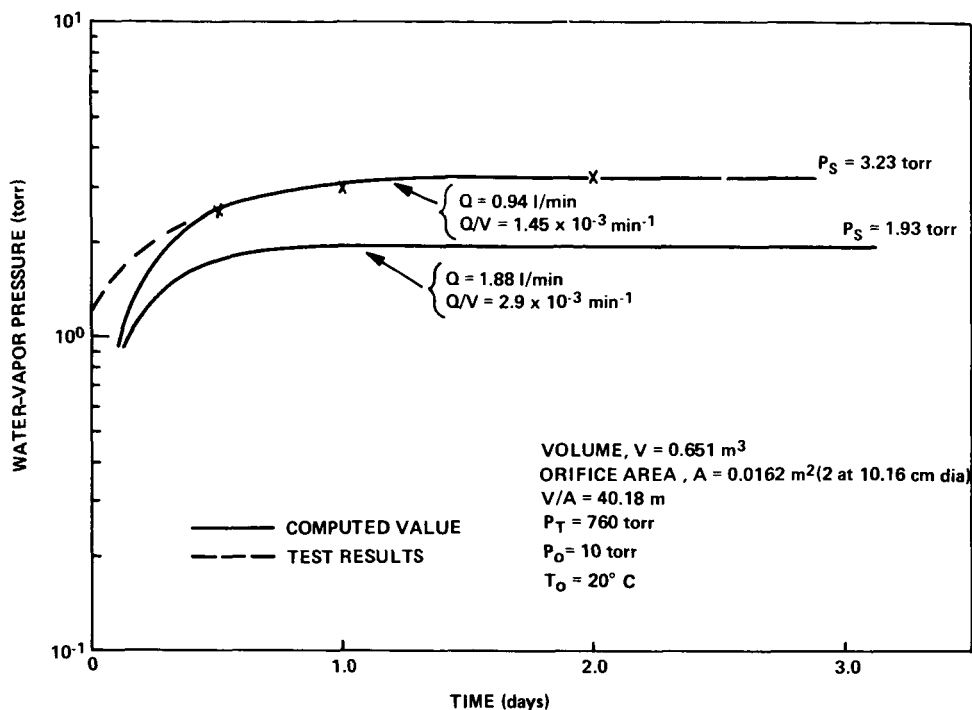

Figure 6. Vapor pressure versus time in an initially dry volume ($V/A = 40.18$) as a function of GN_2 purging flow.

With the dry purging ($P_u = 0$), the final pp from equation 7 or from figure 8 is:

$$P_s = \frac{P_o}{1 + \frac{Q V}{V C}} = 0.029 \text{ torr}$$

so that

$$\phi_s = 0.12\%$$

These RH's are unsafe for electrostatic discharges. After attaining the desired RH ($P_s = 5.94$ torr ($\phi = 25\%$)), it can be maintained with the flow calculated from equation 8 with $G = 0$; i.e.,

$$\frac{Q}{V} = \frac{C}{V} \left(\frac{P_o - P_s}{P_s - P_u} \right) = 2.06 \times 10^{-3} \text{ min}^{-1} \text{ so that } Q = 0.724 \text{ m}^3/\text{min}$$

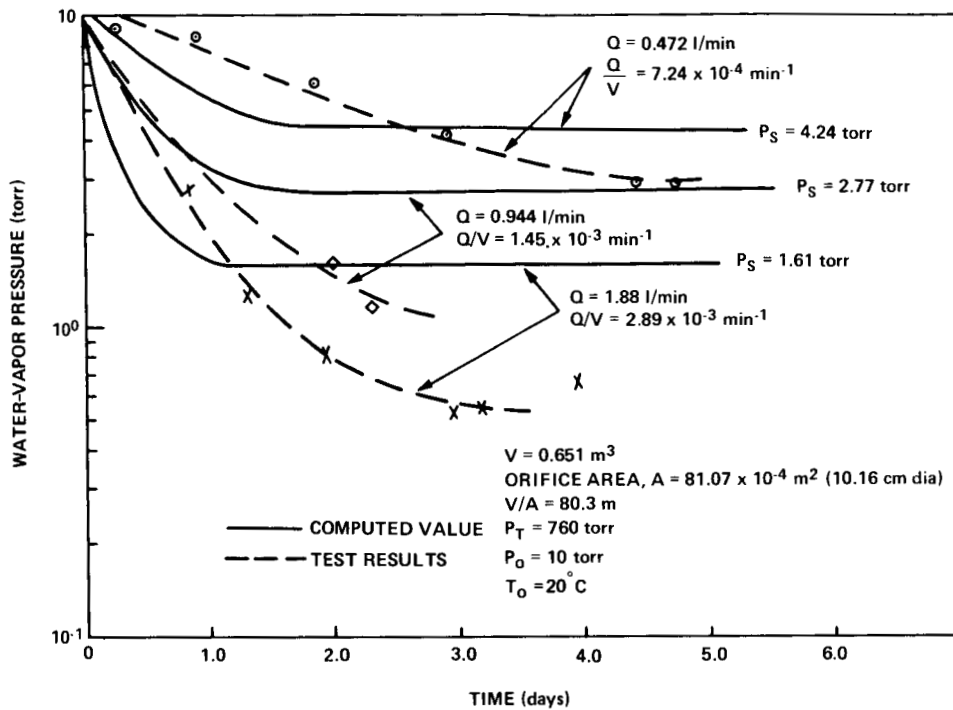

Figure 7. Vapor pressure versus time in volume ($V/A = 80.3$) initially at $P_0 = 10$ torr as a function of GN_2 purging flow.

is the required flow with a purging flow of air at $\phi_u = 10\%$ or, if the purging flow is with dry air ($P_u = 0, \phi_u = 0$), $Q/V = 1.24 \times 10^{-3}$ and $Q = 0.434 \text{ m}^3/\text{min}$, which can be also obtained from figure 8.

As an additional problem, consider the case where a plate of 1 m^2 at $T_1 = -10^\circ\text{C}$ is in the same volume. The plate is covered with an ice thickness of $h = 0.5 \text{ cm}$. What purging flow is required for preventing further formation of ice, and how long will it take, with that purging, to remove the ice from the plate?

With a plate at -10°C in the volume, additional considerations are necessary. The ice-vapor pressure at -10°C is $P_1 = 2.14$ torr. For no condensation, the pressure in the volume must be less than 2.14 torr. For example, consider $P_s = 1$ torr with a purging flow at $P_u = 0.1$ torr. By applying equation 8 in conjunction with the relations of equation 9, the required flow is for $B = 10^{-2}$,

$$Q/V = \frac{C}{V} \left(\frac{P_0 - P_s}{P_s - P_u} \right) + \frac{2172 A_1 P_1}{V(P_s - P_u)} \sqrt{\frac{T_1}{M}} \left(1 - \frac{P_s}{P_1} \sqrt{\frac{T_s}{T_1}} \right) B = 9.94 \times 10^{-3} + 0.283 = 0.293 \text{ min}^{-1}$$

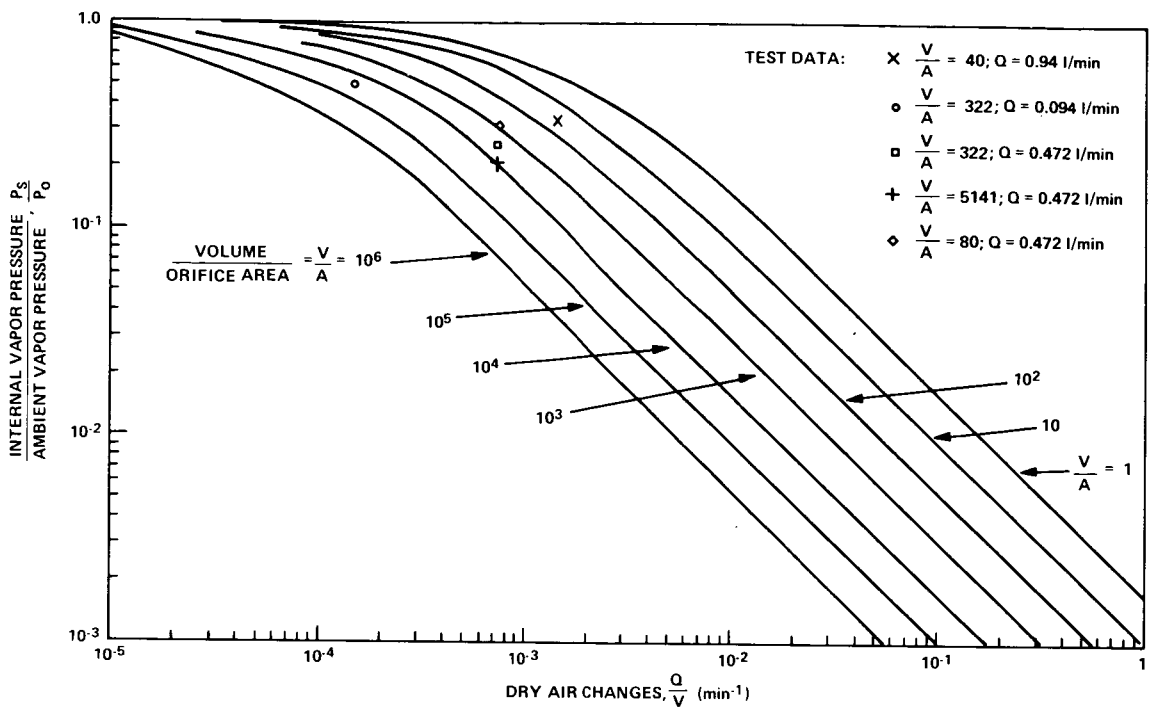

Figure 8. Volume internal vapor pressure versus dry air changes as a function of volume to vent-area ratio.

Therefore, the required purging flow with a water pp, $P_u = 0.1$ torr, is

$$Q = 102.69 \text{ m}^3/\text{min}$$

The evaporation from the plate corresponds to a volume rate $Q = 0.283 \times 350 = 99.05 \text{ m}^3/\text{min}$ and mass rate

$$\dot{m} = Q\rho = 99.05 \frac{M}{22.4} \times \frac{P_s - P_u}{760} \times \frac{273}{T_1} \times 10^3 = 97.83 \text{ g/min}$$

At this rate, the mass of ice ($m = v\rho = Ah\rho = 10^4 \times 0.5 \times 0.92 = 4.6 \times 10^3 \text{ g}$) would leave the plate in $t = m/\dot{m} = 47$ minutes.

If the same flow ($Q/V = 0.293$) would be used to attain $P_s = 1$ in the volume that is initially at $P_0 = 29.35$, the time required is:

$$t = \frac{V}{Q} \ln \frac{P_0}{P_s} = 11.5 \text{ min}$$

These values are approximate because they were dependent on the evaporation coefficient (B), which depends, among other things, on the velocity of air flow over the plate. Further, it is assumed that heat transfer to and from the purging flow is negligible so that the flow remains at constant temperature.

CONCLUSIONS

The water vapor pp control inside a volume, which is important for preventing contamination, corrosion, electrostatic discharge, and water absorption by hygroscopic materials, can be evaluated by using the relations developed here. These relations have been supported with a number of tests, including those for providing data on vapor infiltration rates through various passages sizes. The pp's can be determined as a function of the purging flow, its temperature and humidity, and ambient air conditions, the infiltration passage from the ambient and the temperature, and surface area of a source of vapor inside the volume. The purging flow can be determined for both the initial attainment and the maintenance of a desired vapor pressure inside the volume. The relations can be used to establish conditions for preventing water condensation on critical surfaces and for removing condensation from surfaces. The results are applicable for estimating purging flows and humidity conditions inside shipping containers, storage rooms, clean rooms, and other volumes where personnel entrance and door openings are limited. It is shown that the steady-state purging flow for these volumes can be considerably less than the initial flow required for establishing the desirable conditions. In view of this, economical benefits could be derived by adjusting the flow accordingly.

ACKNOWLEDGMENTS

The author thanks B. Paxson, who set up the various tests, and R. Kruger and J. Diggins for suggesting the investigation.

Goddard Space Flight Center
National Aeronautics and Space Administration
Greenbelt, Maryland January 1978

REFERENCES

1. Sandia Laboratories, *Contamination Control Handbook*, NASA CR 61264, February 1969, p. V-34.
2. American Society of Heating, Refrigerating and Air Conditioning Engineers, *ASHRAE Handbook of Fundamentals*, New York, 1974.
3. Tverskoi, P. N., "Physics of the Atmosphere-A Course in Metereology" (translated from Russian), NASA TTF 288 (Israel Program for Scientific Translations), 1965, p. 286.
4. Perry, R. H., and C. H. Chilton, *Chemical Engineering Handbook*, 5th Ed., McGraw-Hill Book Co., New York, 1973, p. 1358.
5. Dushman, S., and J. M. Lafferty, ed., *Scientific Foundation of Vacuum Techniques*, 2nd Ed., John Wiley & Sons, Inc., New York-London, 1962.
6. Panametric, Inc., "Operating Manual, Model 1000 Hygrometer," Waltham, Massachusetts.
7. American Institute of Physics, *American Institute of Physics Handbook*, 2nd Ed., McGraw-Hill Book Co., New York, 1963, pp. 4-274.

BIBLIOGRAPHIC DATA SHEET

1. Report No. NASA TP-1172	2. Government Accession No.	3. Recipient's Catalog No.	
4. Title and Subtitle Water-Vapor Pressure Control in a Volume		5. Report Date March 1978	
		6. Performing Organization Code 726	
7. Author(s) John J. Scialdone		8. Performing Organization Report No. G7802-F6	
9. Performing Organization Name and Address Goddard Space Flight Center Greenbelt, Maryland 20771		10. Work Unit No. 975-30-08	
		11. Contract or Grant No.	
12. Sponsoring Agency Name and Address National Aeronautics and Space Administration Washington, D.C. 20546		13. Type of Report and Period Covered Technical Paper	
		14. Sponsoring Agency Code	
15. Supplementary Notes			
16. Abstract The variation with time of the partial pressure of water in a volume that has openings to the outside environment (ambient) and includes vapor sources has been evaluated as a function of the purging flow and its vapor content. Experimental tests to estimate the diffusion of ambient humidity through openings and to validate calculated results have been included. The purging flows required to produce and maintain a certain humidity in shipping containers, storage rooms, and clean rooms can be estimated with the relationship developed here. These purging flows are necessary to prevent the contamination, degradation, and other effects of water vapor on the systems inside these volumes.			
17. Key Words (Selected by Author(s)) Humidity, Cryogenic surface, Contamination, Clean rooms, Environment		18. Distribution Statement STAR Category 45 Unclassified—Unlimited	
19. Security Classif. (of this report) Unclassified	20. Security Classif. (of this page) Unclassified	21. No. of Pages 20	22. Price* \$4.00