

General Disclaimer

One or more of the Following Statements may affect this Document

- This document has been reproduced from the best copy furnished by the organizational source. It is being released in the interest of making available as much information as possible.
- This document may contain data, which exceeds the sheet parameters. It was furnished in this condition by the organizational source and is the best copy available.
- This document may contain tone-on-tone or color graphs, charts and/or pictures, which have been reproduced in black and white.
- This document is paginated as submitted by the original source.
- Portions of this document are not fully legible due to the historical nature of some of the material. However, it is the best reproduction available from the original submission.

NASA

Solar Power Satellites

No 7
DRA

SQT-14



Presented by

Christopher C. Kraft, Jr.
Director

Lyndon B. Johnson Space Center
Houston, Texas

(NASA-TM-79434) SOLAR POWER SATELLITES
(NASA) 7 p HC A02/MF A01

CSCL 10A

N78-21612

G3/44
Unclas
15188

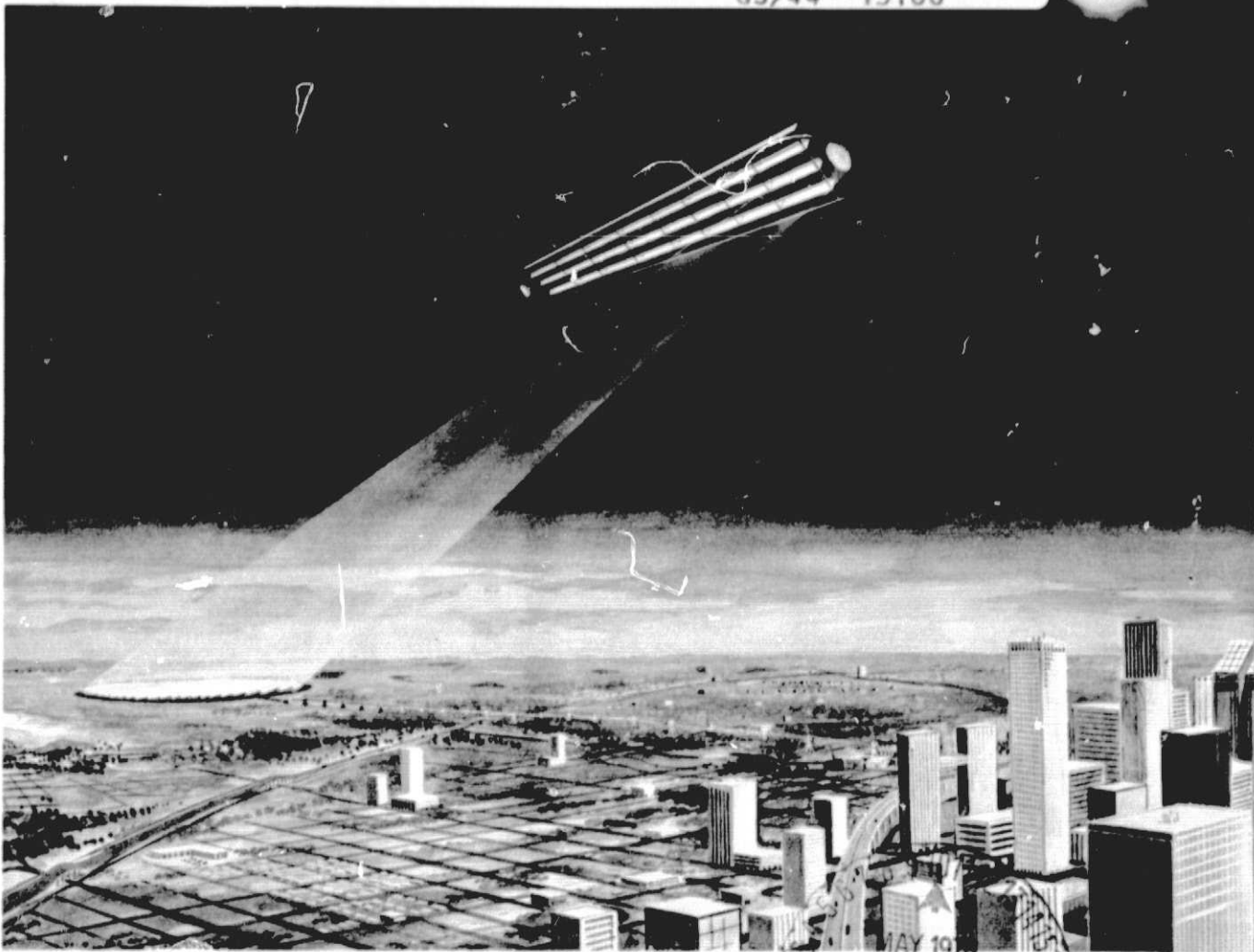
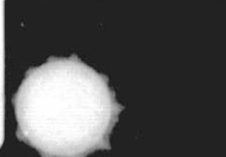

Introduction

The problem of meeting the world's energy needs at an acceptable cost looms larger as time proceeds. The requirement to seek out and bring new sources of energy into use consequently requires an increasing share of our resources and interest. There appears to be no lack of new energy options to pursue; however, the job is to select the more viable approaches, hopefully more than one, set our goals, and get the effort underway.

This does not mean that no efforts are underway at the present, but the scope and intensity of the present effort do not match my perception of the importance of the problem. My background is not of the energy business; however, my recent association with matters related to energy has brought home to me several features of the business, including its enormity and complexity; but perhaps more importantly, the pervasiveness with which energy affects our total lifestyle and culture and hence its overwhelming importance.

Today I would like to provide you with a perspective of one of the many advanced energy options that have been proposed. This concept involves the use of space satellites to collect and transfer solar energy to Earth. Although I and my colleagues are not experienced in conventional energy systems, this concept is so uniquely a space system that we feel competent to evaluate its feasibility and possibilities.

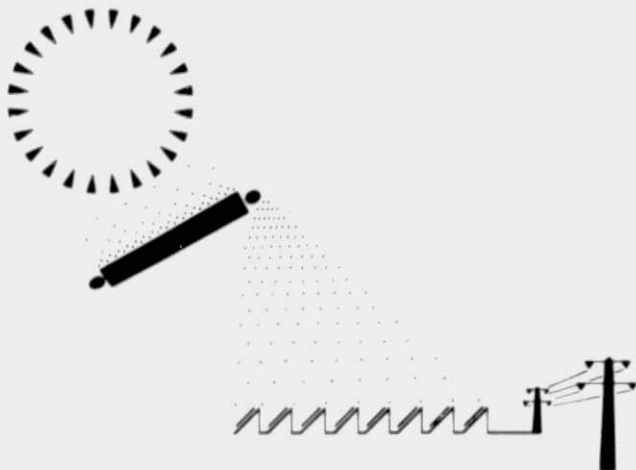

Figure 1

Solar power satellite concept

Concept

The relatively straightforward concept is illustrated on the cover and in figure 1. A large solar collector is located in space, some 35,800 kilometers (22,000 miles) above the Earth in what is termed geosynchronous equatorial orbit. In such an orbit, the satellite remains fixed relative to a point (or a city) on the Earth. Solar energy impinges on the collector where it is converted into electricity. The electricity is then converted into microwave energy and transmitted to Earth. It is received by an antenna and reconverted into electric power and introduced into a utility network.

Although the concept is simple, the implementation of such a project would be a large research, development, and operational task; but more about that later. First, let us review the apparent advantages of the concept. We can ask the question in the context of solar energy; that is, why go to the trouble of placing the collector in space rather than on the ground and why this concept vis-a-vis any other advanced energy concept?

Locating the collector 35,800 kilometers above the Earth results in the collector being in sight of the Sun on practically a continuous basis; consequently, there is no nighttime when energy, and hence electricity, cannot be available. The very small amount of time that the collector cannot view the Sun occurs near midnight at several times in the year. These times, specifically known beforehand, would be used for maintenance activities.

Energy from the Sun to the Earth is significantly reduced by the normal atmosphere and can be virtually eliminated by cloud cover. These effects are negated in the satellite concept by the use of the microwave transmission. By the use of proper frequencies, the energy collected can be transferred to the Earth on a continuous basis virtually independent of atmospheric and cloud conditions.

These factors result in 6 to 15 times more sunlight falling on the collector in space than a similar sized collector on Earth over a given period of time of at least 24 hours. The near-continuous operational capability provides a "baseload" capability of energy generation, and it is assumed that we will need a continuing increase in our "baseload" energy systems as well as other sources to provide energy on an intermittent basis.

The use of microwave transmission to relay the power to ground being independent of cloud conditions offers a high degree of geographic flexibility. The system does not have to cater to areas with a high percentage of cloud-free days. The satellite's location in orbit above the Equator, however, would reduce its effective use in polar and subpolar regions.

In summary, the near-continuous access to sunlight provided by the space location and the freedom from atmospheric and cloud cover are the basic advantages provided by the satellite power concept. These advantages must be weighed against the implementation task. Numerous studies of the concept have been made by industry and governmental agencies. I will briefly describe the results of one of these studies in the remainder of my discussion.

ORIGINAL PAGE IS
OF POOR QUALITY

System Description

Figure 2 presents a typical system configuration resulting from an initial study. This configuration produces a total of 10,000 megawatts of power at the ground rectennas for introduction into the electrical grid. Five thousand megawatts are available from each of two rectennas that operate with the same satellite. This particular two-antenna-rectenna combination is not required, but it is convenient to "balance" the space solar power station.

The large size (5 by 25 kilometers) of the satellite is related to its large power output capability. Additional studies will be required to determine the optimum size for the solar power stations, although they are expected to be quite large for reasons of economy. An additional consideration for using this size for the study was the projected requirement for large electrical parks of this size in the period 2000 and beyond.

The configuration illustrated contains silicon solar cells operating at a conversion efficiency of 10 percent at 373 K (100 °C). Reflectors are used to concentrate the sunlight on the solar cells. The energy from the solar cells is converted to microwave energy and transmitted to Earth at a frequency of 2.45 gigahertz. The efficiency of this conversion and transmission is estimated to be approximately 60 percent, resulting in an overall collection-conversion-transmission efficiency of 6 percent. The transmitting antenna consists mainly of microwave generators, in the form of klystrons or amplifiers, and waveguides.

The ground-based rectenna or rectifying antenna collects the microwave radiation from space and rectifies this power into direct current. The rectenna elements consist of a half-wave dipole antenna and a half-wave rectifier (Schottky barrier diode).

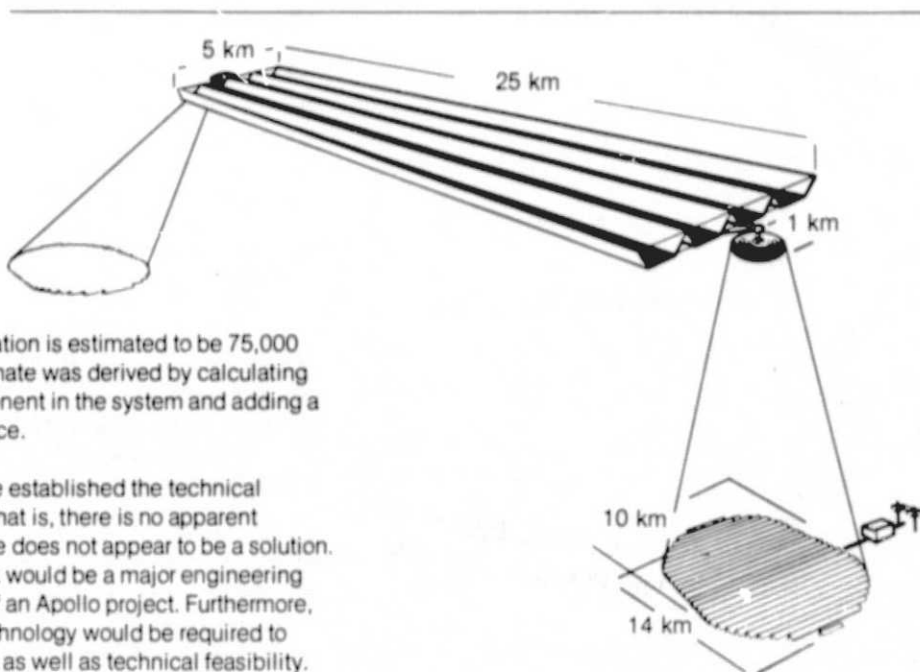

The weight of the configuration is estimated to be 75,000 metric tons. This total estimate was derived by calculating the weights of each component in the system and adding a 50 percent growth allowance.

This and other studies have established the technical feasibility of the concept; that is, there is no apparent requirement for which there does not appear to be a solution. On the other hand, the task would be a major engineering undertaking on the scale of an Apollo project. Furthermore, significant advances in technology would be required to achieve economic viability as well as technical feasibility.

Costs

The prediction of costs 15 to 20 years in the future is a hazardous undertaking, and yet no energy source can be evaluated without economic considerations. Consequently, estimates have been made and the results show that potential costs are in a range such as to warrant continued investigation of the concept.

A range of costs was estimated for different projections of technology. This range extends from a low of 30 mills per kilowatt hour to a high of 115 mills per kilowatt hour. The numbers are associated with costs to the power company at the electrical grid. The lower end of the cost range reflects optimism in technological advancement, where the high end reflects a much more conservative approach. Costs in the range of 50 to 60 mills per kilowatt hour do not appear unreasonable. For perspective, individual consumers are now paying anywhere from 25 to 75 mills per kilowatt hour in different parts of the country.

The cost of the power from this system is affected by two primary components. These are the cost of the solar cells, or energy conversion units, and the cost of transportation to space.

Solar cells have been used in space for a number of years. Interplanetary spacecraft, communications satellites, the manned Skylab, and many other systems have made use of these devices, which have proved to be extremely reliable. Those uses, however, have resulted in a relatively modest total number of cells, which did not warrant the techniques or investments for truly large-scale production.

Figure 2 Typical solar power satellite configuration

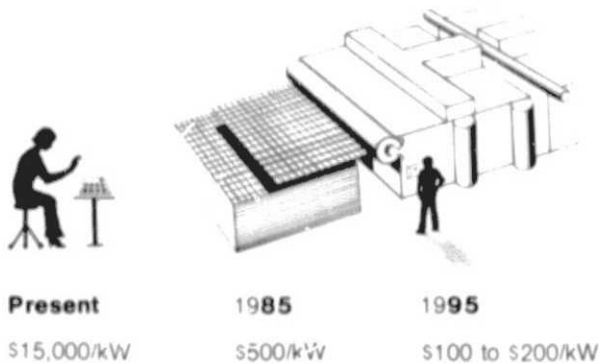

Figure 3 Solar cell development

In recent years, the Department of Energy has sponsored programs to reduce the cost of solar cells for terrestrial use (fig. 3). A goal of \$500 per kilowatt by 1986 has been set, with projections of \$100 to \$300 per kilowatt by the year 2000. Recent surveys of industry involved in the program give confidence that the 1986 goal will be met. These goals and projections have been used as the basis for the current studies.

NASA's current largest development project is the Shuttle transportation system (fig. 4). This system was designed to provide a basic space transportation system for the 1980's, replacing a number of types of launch vehicles now in use. The new system is designed to significantly reduce the cost of moving men and material into space. The reduction is being achieved by recovering and reusing a major part of the system. This recoverable part of the system, called the Orbiter, which looks somewhat like an aircraft, lands on a prepared runway upon returning from space (fig. 5). It is checked out, mated with a new fuel tank and auxiliary rockets, and reused. It carries a payload of up to 27.2 metric tons (60,000 pounds) in a compartment approximately the size of a Greyhound bus.

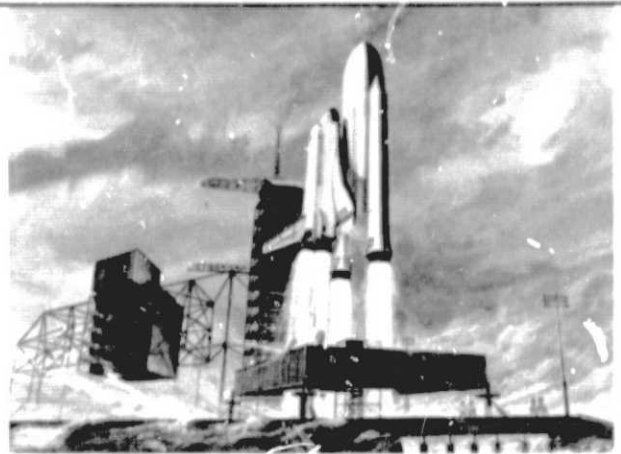

Figure 4 Shuttle/Orbiter launch

The solar power system would require a new cargo transportation system (fig. 6) to achieve economic viability. This new system would reduce transportation costs lower than the Shuttle by recovering the total system on each flight for multiple reuse. Studies indicate both the feasibility and economic gains of such a system when used on a large scale as required for the solar power satellites. The Shuttle system, however, is a primary ingredient of any solar power satellite program. It would provide transportation to space for the many test activities in the 1980's and could serve as a personnel carrier in implementing a full-scale program.

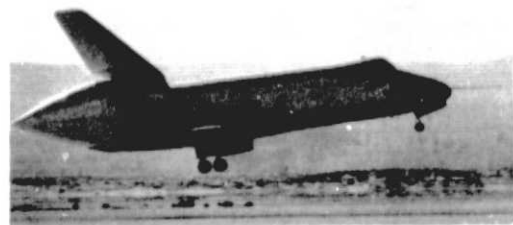
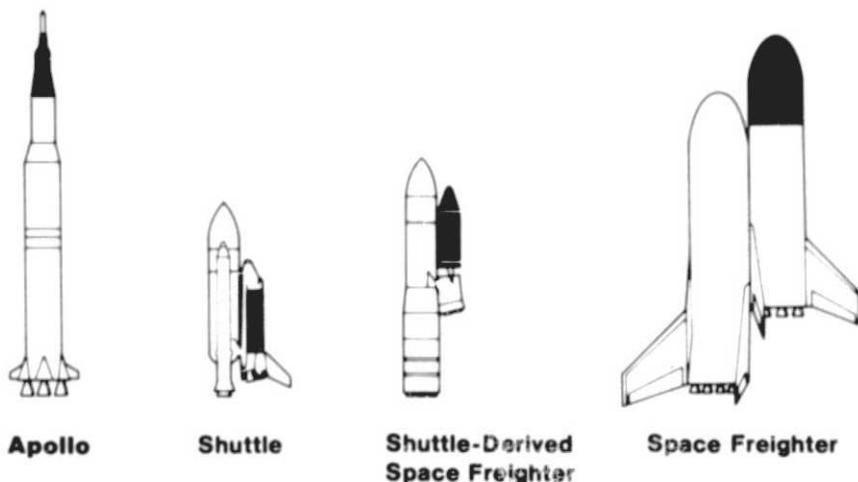

Figure 5 Orbiter landing



ORIGINAL PAGE IS
OF POOR QUALITY

Figure 6 Space transportation

Environmental Considerations

The solar power satellite concept provides a remarkably "clean" source of energy. There is no air or water pollution associated with the operation of the satellite. Moreover, the "waste heat" generated in the conversion of solar energy to electricity is primarily radiated to space rather than requiring large quantities of cooling water. There are significant land requirements for the rectenna. However, it should be noted that the rectenna is not a continuous structure and some 75 percent of normal sunlight will reach the Earth. It may or may not be practical to put this land to multiple use, but vegetation or other natural conditions may continue under the rectenna.

The operation of the satellite involves the use of the microwave transmission system. The characteristics of this microwave beam as it may affect the environment or living creatures is a legitimate area of interest and has been carefully considered in the studies to date. It is most important to understand the levels of power associated with the beam. The power in the center of the beam has been limited to 23 milliwatts per square centimeter. This level has been used in design studies because estimates indicate that there would be no nonlinear effects in the ionosphere at this level. Higher levels may not be detrimental, but the situation is less understood.

The beam is shaped such that the power at the edge of the rectenna is less than 1 milliwatt per square centimeter. For reference, the allowable leakage rates of new and old microwave ovens are 1 and 5 milliwatts per square centimeter, respectively.

These facts are not presented with the idea that we have a full understanding of all possible microwave considerations. We would make the point, however, that the levels being considered are not beyond our past and current experiences; and, yes, it is an area that requires more study and testing for the present application, as well as for the many other applications that microwave radiation is involved in our daily lives.

A final point regarding the microwave beam — the question is often asked, "What happens if the beam is not pointed directly at its rectenna?" The satellite and rectenna are an "interlocked system." If the satellite is not pointed at the rectenna, the beam "defocuses" and the power levels drop to a very low 0.003 milliwatt per square centimeter.

Program Implementation

At the present time, this concept is being evaluated as a joint study of the Department of Energy and NASA. The studies are directed toward the feasibility and viability of this concept related to other energy options. The studies are intended to result in recommendations as to whether the option should be pursued and in what manner.

Preliminary studies envision the following program evolution.

- An active ground-based *laboratory and test program* to investigate critical questions
- A series of *space experiments* to provide data that cannot be obtained on Earth
- A number of *space projects* that will provide systems-level information and operational experience
- A decision as to the desirability of implementing a "full-scale" system or a large "pilot plant"
- System development
- Commercialization

It is expected that the first three steps could be accomplished in the 1980's. The rate at which they are accomplished would obviously be a function of resources applied. The decision to implement a full-scale system in the late 1980's would be based on the information from the three previous activities and the situation in regard to other energy options at that time. The accomplishment of the three initial steps would cost on the order of \$5 to \$10 billion, spread over a 10-year period. Within that period, there would be additional "decision points," which would allow commitment of resources to be based on progress within the program and events external to the program. The following paragraphs provide some detail as to the contents of the three initial program steps.

Bead-forming section

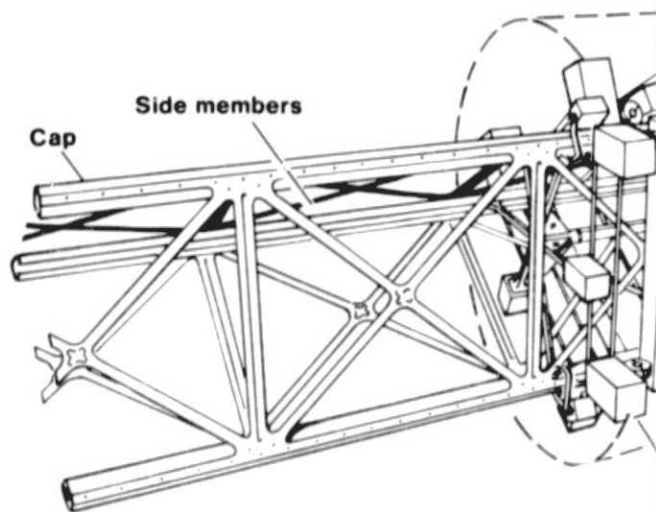

The completed and ongoing studies have identified several areas that require definitive data to confirm analysis or to answer questions not amenable to analysis. Two examples will provide insight into this activity. It was earlier noted that the power of the microwave beam as it passes through the ionosphere is 23 milliwatts per square centimeter. Analysis does not indicate any deleterious effect on the ionosphere; however, tests would be desirable to confirm the absence of adverse effects on the environment. Such a test does not require a satellite with microwave transmission from above. A ground system, such as the Arecibo facility in Puerto Rico, could be upgraded to allow testing at these power levels. Such a test could also provide information on the potential effects of ionospheric heating on communications, electronic equipment, and X-ray astronomy research. The tests would cost on the order of \$4 million. Needless to say, such studies are of additional basic scientific interest.

The system requires the conversion of electricity from the solar cells to microwave radiation. Microwave generators such as klystrons are required. Magnetrons are the devices used in microwave ovens for this function. Another device called an "amplitron" has been under study for the last several years. Laboratory tests are required to provide definitive performance and noise data on these devices to confirm existing analyses. The building and testing of such devices would cost on the order of \$2 to \$3 million.

Similar tests are required in a number of specific areas within the system. The laboratory and test efforts would be geared toward this type of activity, as well as initiating a series of space experiments and planning a number of space projects described later. The total cost of this initial activity would be approximately \$100 million over a 3-year period.

The second activity would consist of a series of space experiments. These experiments would be directed toward developing or demonstrating technologies that cannot be adequately simulated on Earth. Typical of these experiments would be activities dealing with construction of large systems in space. The size of the satellite requires that it be constructed in space in a highly automated fashion. An element of this automated operation may include a "beam builder" (fig. 7) device that would fabricate structural beams for the system from tightly wound, high-density rolls of materials. Other experiments (fig. 8) would include development of various attaching schemes such as ultrasonic welding, and the testing of these very lightweight structures to determine their thermal and other characteristics. This experiment program, which would involve many disciplines, would cost on the order of \$500 million and last for 3 to 6 years.

The third activity would involve conducting a limited number of relatively large projects (fig. 9). These projects would integrate and demonstrate a number of the concepts and techniques studied in the ground tests and space experiments. They would include placing a satellite at geosynchronous orbit as early as possible to evaluate the effect of that environment on the various materials contemplated for use in the project. The early implementation of this project would allow the best evaluation of what is essentially a time-dependent degradation activity.

A second project would involve the construction in space (low Earth orbit) of a relatively large solar array (200 to 500 kilowatts) with a radiating antenna and target antenna to study the characteristics of the microwave beam in space-to-space tests. Heating tests of the microwave generators would also be conducted.

The solar power satellite will operate from geosynchronous orbit. To demonstrate the control of the microwave system, a satellite test would be required from geosynchronous orbit. This activity would also involve manned activity at geosynchronous orbit, and the testing of the associated propulsion systems to transport crews from low Earth orbit and return.

A final project would be required to prove out the selected construction concept and provide productivity data. This activity would involve the building and demonstrating of a "space factory" or a part thereof.

This series of space projects might require \$5 to \$10 billion over a 10-year period. The cumulative results of these ground and space activities would provide the basis for implementation of large commercial systems or, more conservatively, an intermediate (500 to 1000 megawatt) "pilot plant," which would provide a further demonstration of the system's viability.

Figure 7 Beam builder machine concept

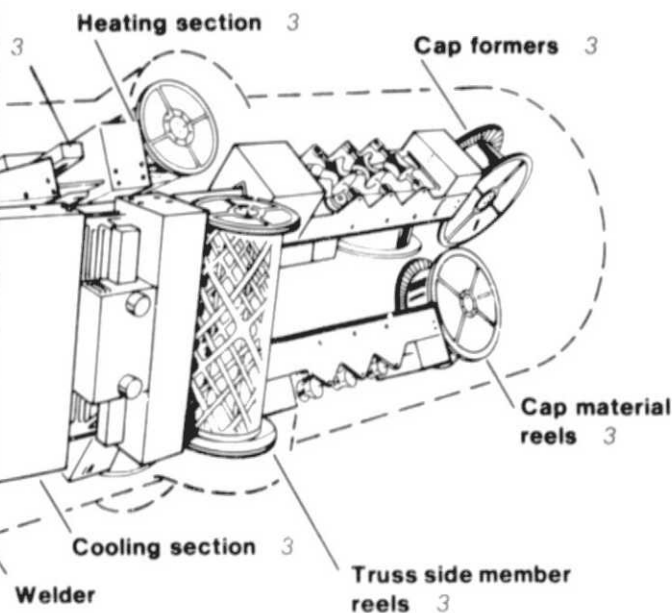

**ORIGINAL PAGE IS
OF POOR QUALITY.**

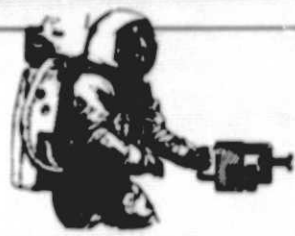

Space welding



Geosynchronous environment materials experiment

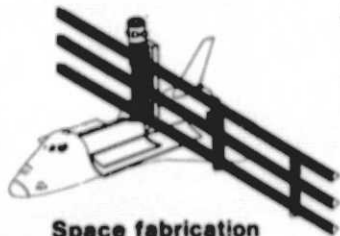

Space fabrication

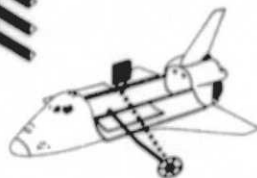

Subsystem experiments

Figure 8 Flight experiments

Figure 9 Flight projects

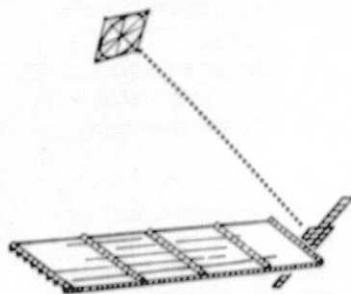

Microwave energy transmission test

Geosynchronous orbit



Phase control/ ionosphere test

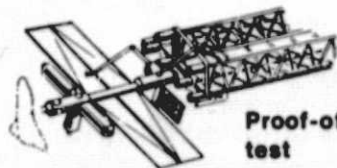

Proof-of-construction test

Concluding Remarks

An advanced energy concept has been described, including the advantages of the basic concept, system characteristics, cost and environmental considerations, and the outline of a plan for the further evaluation and implementation of the system. Considerably more information is available on such subjects as natural resource requirements, energy payback, alternate energy-conversion techniques, and satellite configuration. Time precludes a full discussion of this information, which is available in a number of documented studies.

We have concluded that the satellite concept is competitive with other advanced power generation systems when a variety of factors are considered, including technical feasibility, cost, safety, natural resources, environment, baseload capability, location flexibility, land use, and existing industrial base for implementation. From a more basic standpoint, the system uses the inexhaustible fuel of the Sun, is not inhibited by the weather or climate, does not require water for cooling, and radiates its waste heat from conversion into space rather than in heating the Earth's atmosphere.

Finally, this activity need be placed in context with the space program. NASA over the past 15 years, in conjunction with the aerospace industry, has developed a significant capability for organizing and conducting very large high-technology programs. The Space Shuttle Transportation System, now nearing completion, represents the latest of these large programs. Within earlier programs, it has been demonstrated that man can safely and reliably operate 463,000 kilometers (250,000 miles) away from Earth, and that he can live and work in space for long periods of time.

We foresee a future need for large structures in space and relatively large power supplies for space use. We believe these general needs are compatible with the research and development evaluation of the satellite power concept over the next 10 years. Consequently, we see considerable merit in applying the talents of an organized government-industry technology capability to a major Earth problem as we continue to develop and expand man's activities in space.

National Aeronautics and
Space Administration

Lyndon B. Johnson Space Center
Houston, Texas 77058
AC 713 483-5111