

General Disclaimer

One or more of the Following Statements may affect this Document

- This document has been reproduced from the best copy furnished by the organizational source. It is being released in the interest of making available as much information as possible.
- This document may contain data, which exceeds the sheet parameters. It was furnished in this condition by the organizational source and is the best copy available.
- This document may contain tone-on-tone or color graphs, charts and/or pictures, which have been reproduced in black and white.
- This document is paginated as submitted by the original source.
- Portions of this document are not fully legible due to the historical nature of some of the material. However, it is the best reproduction available from the original submission.



Technical Memorandum 78108

(NASA-TM-78108) A PORTABLE L-BAND VOICE
TRANSCIVER FOR SATELLITE COMMUNICATION
(NASA) 30 p HC A03/MF A01

CSCI 17B

N78-24403

Unclas

G3/32 21280

A Portable L-Band Voice Transceiver for Satellite Communications

J. Maruschak and D. Nace

MARCH 1978

National Aeronautics and
Space Administration

Goddard Space Flight Center
Greenbelt, Maryland 20771



A PORTABLE L-BAND VOICE TRANSCEIVER
FOR SATELLITE COMMUNICATIONS

J. Maruschak
D. Nace

March 1978

GODDARD SPACE FLIGHT CENTER
Greenbelt, Maryland

CONTENTS

	<u>Page</u>
ABSTRACT	v
INTRODUCTION	1
DESIGN CONSIDERATIONS AND OPERATION	5
Receive Signal Path	5
Transmit Signal Path	15
ALIGNMENT AND TESTING	19
PACKAGING	22
COST	22
CONCLUSIONS	23
ACKNOWLEDGMENTS	24

ILLUSTRATIONS

<u>Figure</u>		<u>Page</u>
1	Photograph of the Briefcase Transceiver	2
2	L-Band Voice Transceiver Block Diagram	4
3	Photograph of the 20 Watt Power Amplifier	16

TABLES

<u>Table</u>		<u>Page</u>
1	L-Band Transceiver Subsystem Specifications, Model Numbers and Costs	8
2	Specifications of the Icom IC-30A UHF/FM Transceiver . . .	13
3	Electrical Specifications of the L-Band Voice Transceiver . .	21

A PORTABLE L-BAND VOICE TRANSCEIVER
FOR SATELLITE COMMUNICATIONS

J. Maruschak

D. Nace

ABSTRACT

A portable L-band voice transceiver was developed as a feasibility model which can provide a half-duplex voice link to another terminal via the L-band transponder on the Applications Technology Satellite, ATS-6.

The narrow band FM transceiver utilizes commercial subsystems including a UHF transceiver, provides an RF output power of 20 watts, weighs less than 25 lbs., is housed in a plastic briefcase, can be powered by an automobile electrical system, and has been successfully operated with ATS-6 on numerous occasions. The cost of the transceiver subsystems is approximately \$5000. Design considerations and operation of the transceiver are described, along with alignment and testing procedures, packaging and cost considerations, subsystem performance requirements and overall transceiver performance characteristics.

A PORTABLE L-BAND VOICE TRANSCEIVER FOR SATELLITE COMMUNICATIONS

INTRODUCTION

The portable L-band voice transceiver, also known as the briefcase transceiver because of its housing, was developed and built at Goddard to be the main component of a small earth terminal. When connected to a simple helical antenna, it provides a half-duplex voice link with another terminal via the L-band transponder on-board the Applications Technology Satellite ATS-6. Intended as a feasibility model, the transceiver was developed in-house, using standard models of commercially available subsystems wherever possible, for the sake of expediency.

It is housed in a government-issue plastic briefcase measuring $18 \times 13 \times 4\frac{1}{2}$ inches and weighs less than 25 pounds. Since it was originally intended for mobile (automobile) application, it operates from a 12 volt DC source. In the transmit mode, when the 20 watt amplifier is operating, the transceiver draws approximately 8 amps; in the receive mode, it draws approximately 2 amps.

A photograph of the transceiver is shown in Figure 1.

The purpose of the transceiver is two fold:

1. To show the potential of current microwave technology to reduce the physical size of earth terminal transceivers—the briefcase transceiver

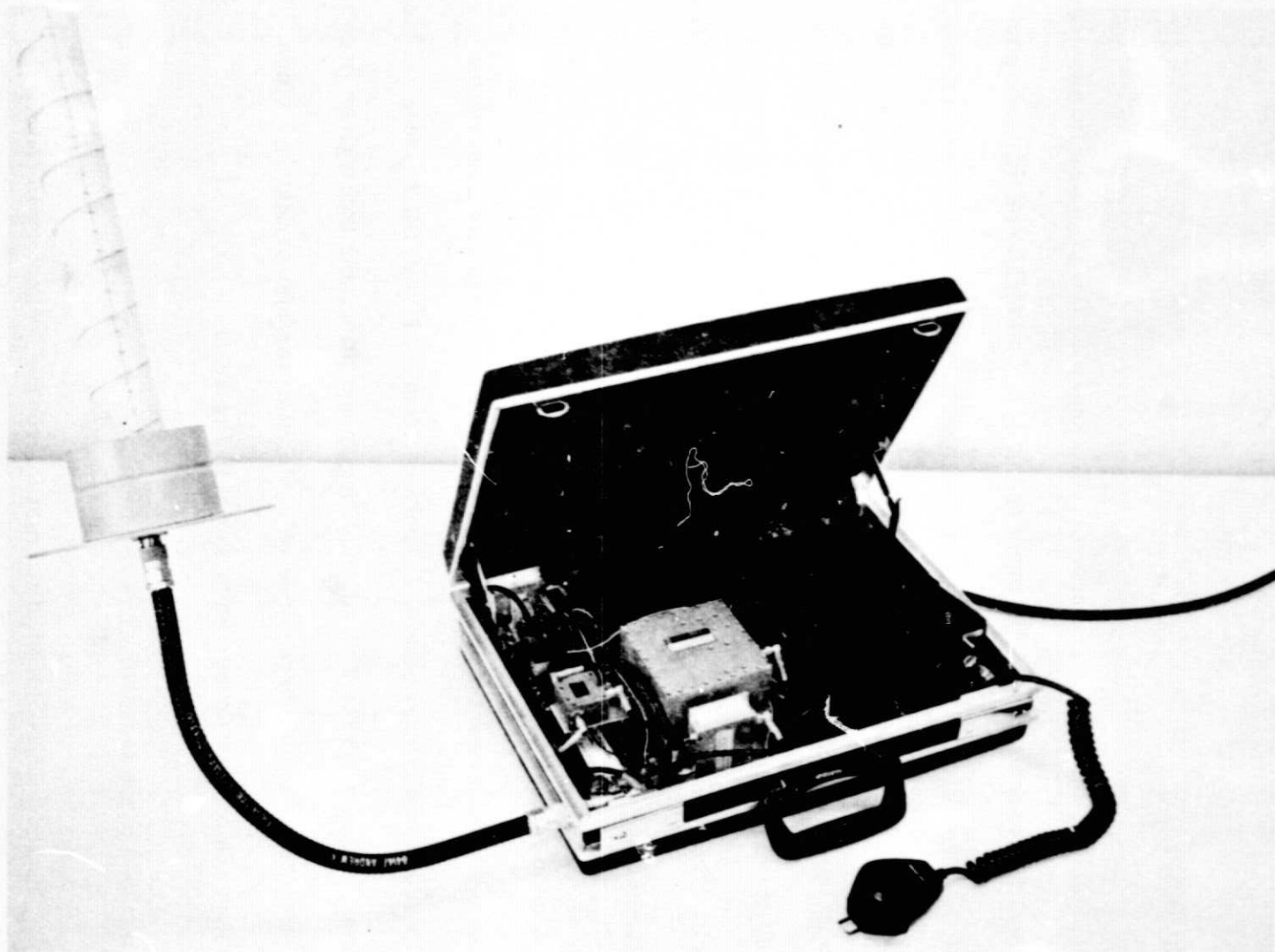

Figure 1. Photograph of the Briefcase Transceiver

ORIGINAL PAGE IS
OF POOR QUALITY

is believed to be the smallest civilian satellite communications transceiver in existence.

2. To provide the means for performing the mobile and portable earth station communications experiments that this small size allows.

The transceiver was implemented in a very straightforward manner and essentially consists of a consumer grade commercial UHF/FM transceiver and UHF to L-band/L-band to UHF frequency translators and amplifiers. See Figure 2. This scheme simplified the overall task, since audio processing, modulation, and demodulation are all provided by the commercial UHF transceiver. Most of the various subsystems required for the UHF to L-band frequency converters were purchased as readily available standard models of commercial equipment whose specifications either met or exceeded the transceiver requirements. In some cases, subsystems were purchased on a lowest-bid basis. This procurement information is mentioned in order to emphasize that this transceiver has not been optimized for small size or for minimum power consumption or for cost effectiveness or for mass producibility. The configuration and form represent the most expedient way to build a few L-band transceivers that grossly approximate the characteristics and performance of commercial transceivers that could evolve in the near future.

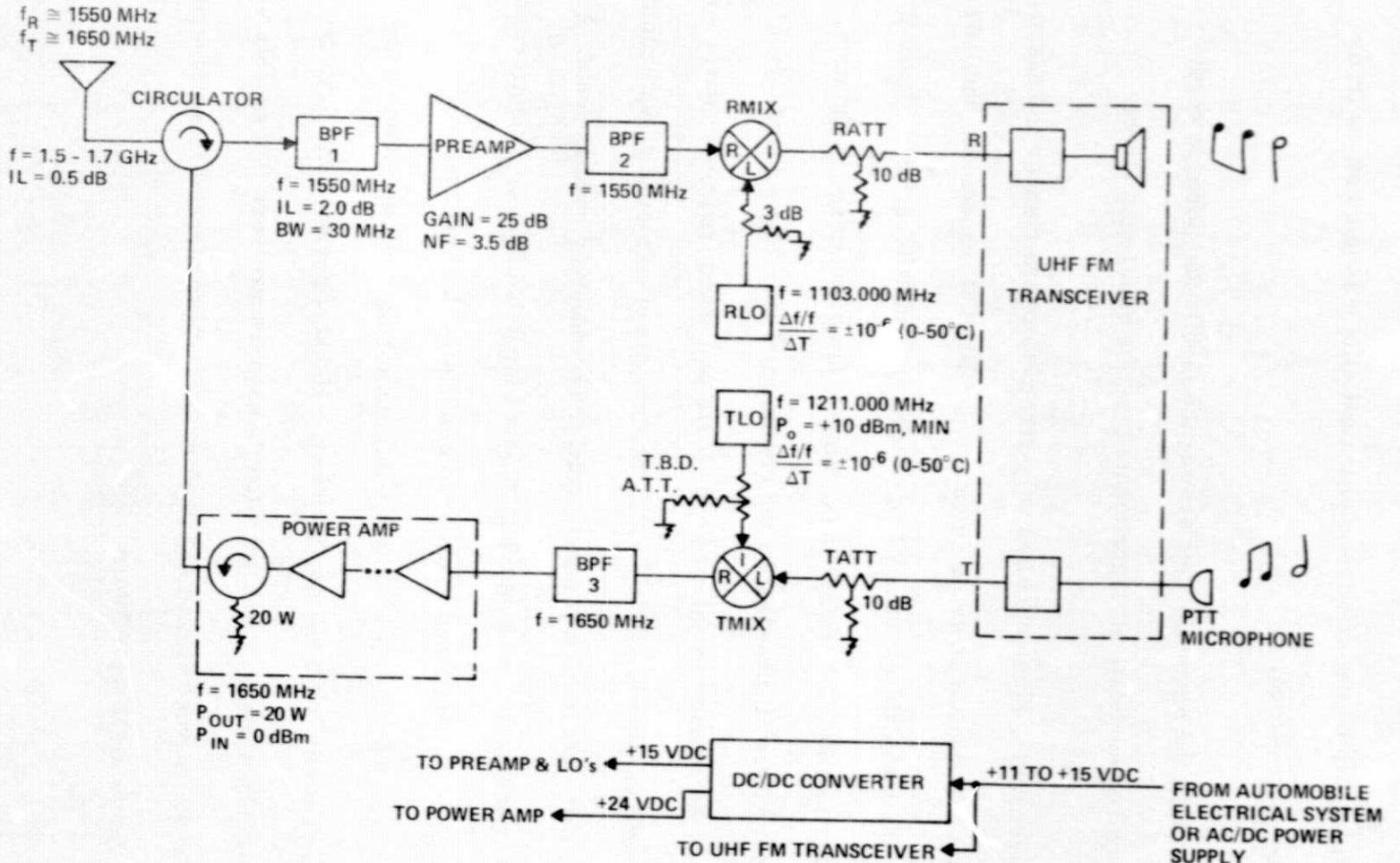

Figure 2. L-Band Voice Transceiver Block Diagram

ORIGINAL PAGE IS
 OF POOR QUALITY

DESIGN CONSIDERATIONS AND OPERATION

Receive Signal Path

The commercial UHF/FM voice transceiver, the Icom model IC-30A, incorporated into the briefcase transceiver, has only one RF connector, labelled "antenna," which is used for both the transmitting and receiving function by means of the internal RF switching relay actuated by the PTT (push to talk) button on the microphone.

Since the UHF transmit and receive signals have to be separated for UHF to L-band conversion, three alternatives for providing this separation were identified: 1) add another RF switching relay, 2) add an appropriate UHF circulator network, or 3) modify the IC-30A. The last alternative was selected and consisted of disconnecting the internal RF switching relay and allowing the existing RF connector to function as the transmit port and adding an additional RF connector, BNC type, directly wired to the receiver input portion of the transceiver. In addition, the 10 watt amplifier portion of the transceiver was disabled.

The block diagram of the briefcase transceiver is shown in Figure 2. The circulator allows one antenna to serve both the transmit and receive function by directing received signals from the antenna to the receiver path and by directing transmit signals from the power amplifier to the antenna. The frequency range of the circulator was specified to be 1500 to 1700 MHz so that the receive

frequency of approximately 1550 MHz and the transmit frequency of approximately 1650 MHz might easily be accommodated. The insertion loss (IL) of 0.5 dB maximum is typical of commercial circulators.

The first element in the receive path is a bandpass filter (BPF1) and its main function is to reflect incidental transmit signal back into the circulator and thus prevent damaging the preamplifier. Transmit signal power at the receive port of the circulator can be appreciable. In this case, the power amplifier provides +43 dBm to the antenna and if the impedance match of the antenna corresponds to a VSWR of 1.5:1 (a respectable impedance match), nearly 1 watt of transmit signal power will be reflected back from the antenna and be directed by the circulator into the receive path. This would be more than enough power to damage the preamplifier. But, because of its reactance at the transmit frequency, BPF1 reflects this power back into the circulator which routes it to the output of the transmit power amplifier where the output isolator routes it to the 20 watt termination.

The 3 dB bandwidth (BW) of this filter, and of all the filters in the briefcase transceiver, was specified at 30 MHz and the number of poles was specified at 4. These values allow a tolerable insertion loss of 2 dB, provide approximately 60 dB of attenuation to the incidental transmit signal power approaching the preamplifier and accommodate the full 6 MHz frequency range of the UHF transceiver even after the narrowing of the receive path bandwidth caused by positioning

an additional filter after the preamplifier. Actually, three pole filters would be more than adequate and in fact two pole filters, designed and fabricated in-house, were used in the first two transceivers because of a lead-time perturbation in the procurement of the four pole commercial filters.

Since the noise figure of the receiver portion of the briefcase transceiver is the sum of the preamplifier noise figure and the insertion loss of BPF1 and the insertion loss of the circulator (all terms in dB), a lower insertion loss alternative to BPF1 was developed in-house to minimize receiver noise figure. This consisted of a two pole band reject filter, implemented in microstrip on a teflon/fiberglass substrate, and exhibited only 0.5 dB insertion loss at the receive frequency and greater than 30 dB attenuation at the transmit frequency. Once receiver tests with the satellite proved an abundance of signal to noise margin, this filter was abandoned because of its larger physical size and the lack of temperature test data.

The main function of the preamplifier is to determine the noise figure of the receiver. A gain of 25 dB causes second stage noise contributions to be negligible and compensates for the losses in the filters and the mixer. The Watkins-Johnson model 737-312 amplifier was selected because of its good noise figure of 3.5 dB maximum, adequate gain, off-the-shelf availability and reasonable price. See Table 1 for specific parameters. The disadvantage of octave bandwidth was eliminated by filters BPF1 and BPF2.

Table 1. L-Band Transceiver Subsystem Specifications, Model Numbers and Costs

Subsystem	Specifications*	Manufacturer** and Model	Cost
Circulator	Form: coaxial Freq. range: 1.5-1.7 GHz, min Insertion loss: .5 dB, max VSWR: 1.25:1, max Isolation: 20 dB, min Power capability: 25W Connectors: OSM	Aertech Model AMF 5844	\$195
Bandpass filters (BPF 1, 2, 3)	Form: coaxial Center freq: 1550 or 1650 MHz 3 dB bandwidth: 30 MHz Insertion loss: 2 dB, max Number of poles: 4 VSWR: less than 1.5:1 over 50% of passband Connectors: OSM	Cirqtel	<\$100
Preamplifier	Frequency range: 1 - 2 GHz Gain: 25 dB, min Noise figure: 3.5 dB, max VSWR: 2.0:1, max Supply voltage: +15 VDC	Watkins-Johnson Model 737-312	\$445

*Either the required specifications or specifications of a readily available model which meets and/or exceeds the requirements.

**Not necessarily the only manufacturer and model which will satisfy the specification.

8
ORIGINAL PAGE IS
OF POOR QUALITY

Table 1--Continued

Subsystem	Specifications	Manufacturer and Model	Cost
Receive mixer (RMIX)	Type: low-level, double balanced Frequency range: R&L ports: 1000-1800 MHz, min I port: 400-500 MHz, min Conversion loss: 9 dB, max Isolation: 25 dB, min Connectors: OSM L port power required: +7 dBm	Watkins-Johnson Model M1J	\$125
Transmit mixer (TMIX)	Type: high-level, double balanced Frequency range: R&I ports: 1000-1800 MHz, min L port: 400-500 MHz, min Conversion loss: 9 dB, max Isolation: 25 dB, min Connectors: OSM Allowable L port power: 200 mw, min	Anzac MD-525-4	\$175
Local oscillators (RLO & TLO)	Type: crystal-controlled, ovenized Frequency: 1211.000 and 1103.000 MHz Freq. stability: $\pm 10^{-6}$ over 0° to $+50^{\circ}\text{C}$ Freq. adjustment: tuning adjustment shall be provided to compensate for crystal aging Output power: +10 dBm, min Supply voltage: +15 VDC Output connector: OSM	Frequency sources Model FS-3020-6	\$710

Table 1—Continued

Subsystem	Specifications	Manufacturer and Model	Cost
Power amplifier	Frequency range: 1500-1700 MHz Power output: 20 watts Power input: .001 watt Output protection: circulator and 20 watt termination DC supply: +24 volts, drawing 2.3 amps in operating mode, 50 ma in standby mode Operating temperature: -30°C to +60°C Size: 2 X 8.2 X 0.5 inches	GSFC/Code 715	Components cost approximately \$1000
DC/DC converter	Input voltage range: +11 to +15 VDC Output terminal: #1: +24 VDC providing 0 to 2.5 amps Output terminal #2: +15 VDC providing 100-500 ma Regulation: ±0.5 VDC max, for any combination of load and input voltage Operating temperature: -10°C to +50°C Isolation: all inputs & outputs shall be isolated Size: less than 4 X 4 X 7 inches	Todd Products Model 2-2XS421S	\$450
FM transceiver	Consumer grade, 10 and 1 watt output power, 22 channel, 440 to 450 MHz, FM transceiver configured for mobile operation. See Table 2 for specifications.	Icom Model IC-30A	\$400

The second bandpass filter (BPF2) is required for image rejection. In this case, the image frequency is approximately 650 MHz so that a two pole filter with a bandwidth of 30 MHz is more than adequate to provide a nominal rejection of 30 dB. The absence of this filter can, depending upon the gain and noise figure of the preamplifier at the image frequency, increase the receiver noise figure.

The receive path mixer, RMIX, has no special requirements placed on it as long as it can accommodate the proper frequencies. The 3 dB attenuator between RMIX and the receive path local oscillator, RLO, insures oscillator stability by presenting it with a resistive load.

RLO drives RMIX and enables the L-band to UHF frequency conversion. Since narrowband receivers such as the Icom IC-30A will tolerate only about 2 kHz frequency drift before the received audio becomes distorted, good frequency stability is required of RLO. Accordingly, an RLO frequency drift of 1 kHz was allowed. This 1 kHz, taken as a fraction of the actual RLO frequency, was expressed as a frequency stability of 10^{-6} , and was the specification used for the oscillators, both transmit and receive. This specification was defined to apply to a temperature range of 0° to $+50^{\circ}\text{C}$, not only because this was the manufacturer's conventional definition but because it was judged that this temperature range was adequate for an experimental system, and because it was

determined that the oscillators would never fall below 0°C due to the power dissipation of the other transceiver subsystems in the confinement of the transceiver packaging, and because it was felt that the extra \$300 per oscillator required for a stability of 10^{-8} would be wasted unless it was proven by measurement to be necessary. Commercial transceivers are designed to operate over a temperature range of from -30°C to +60°C.

A provision for frequency adjustment of the oscillators was specified in order to compensate for crystal aging and in order to be able to convert the incoming L-band signals to the exact UHF frequency required by the Icom IC-30A.

The attenuation of the receive attenuator, RATT, was selected during satellite testing of the briefcase transceiver. A 10 dB attenuator allows the signal strength meter of the Icom transceiver to indicate approximately half scale during nominal ATS-6 transmissions.

Having been down-converted to UHF, the received signal is routed through RATT to the Icom IC-30A where additional down conversion, channel selection, demodulation and audio processing are accomplished. The UHF transceiver specifications are listed in Table 2.

Table 2. Specifications of the Icom IC-30A UHF/FM Transceiver

GENERAL:	
Frequency coverage	444.00 - 449.99
Number of transistors	Transistors 40
	FET's 24
Diodes	Diodes 3
	IC's 3
	Freq. range 440-450 MHz
	For specifications without
	retuning. 3 MHz
Freq. stability	$1 \times 10E-5$ (0.001%)
Impedance	50 ohms
Voltage	13.8V \pm 15%
Polarity	Negative ground
Current	Receiver squelched . . .250 ma
	Receiving signal550 ma
	TX (10W) 2.8 A
	TX (1W) 1.3 A
Size	58 X 156 X 244 mm
Weight	2.4 kg
Modulation type	F3
Antenna input	50 ohms
TRANSMITTER:	
Freq. range	444.00 - 449.99, 22 channels
RF power output	HI 10W
	LOW 1W
Maximum frequency deviation	Adjustable between 3 to 16 kHz
Audio input	500 ohms
Modulation system	Variable reactance phase modulation
Microphone	500 ohms—dynamic microphone with push button switch
Crystal mult. factor	24
Crystal range	18 MHz
Spurious response	-60 dB or less

Table 2—Continued

RECEIVER:	
Freq. range	444.00 - 449.99, 22 channels
Modulation acceptance	Maximum 16 F-3
I. F. frequencies	1st—10.69 MHz 2nd—455 kHz
20 dB quieting sensitivity	-4 dB or less (0 dB = 1 microvolt)
Bandwidth	±15 kHz at the -6 dB point
Selectivity	±25 kHz (-50 dB) point
Squelch sensitivity	-80 dB or less (0 dB = 1 microvolt)
Spurious rejection	60 dB or more
Audio power output	1.2 W

Transmit Signal Path

The Icom transceiver provides a modulated UHF transmit signal which the transmit path circuitry must up-convert to L-band and amplify to 20 watts. Since the Icom IC-30A provides a signal level of +30 dBm (the optional +40 dBm amplifier had been disabled), it was decided that high-level mixing would be used to keep the signal at as high a level as possible ahead of the 20 watt power amplifier in order to minimize the gain required of the power amplifier. Conventional low-level mixers generally require a local oscillator level of +7 dBm and must be used with a signal level of less than 0 dBm in order to insure that conversion compression remains negligible. If a conventional mixer had been used for TMIX the Icom transmit signal of +30 dBm would have been attenuated to the 0 dBm required by the mixer and the resultant signal applied to the input of the 20 watt power amplifier would have been on the order of -10 dBm. The gain then required by the power amplifier would have been 53 dB.

Instead, a high level mixer, the Anzac MD-425-4, was used in the scheme shown in Figure 2 and resulted in the delivery of 0 dBm of transmit signal to the power amplifier with the advantage that only 43 dB of power amplifier gain is required. This is accomplished by reversing the conventional levels of signal and local oscillator at TMIX and attenuating the Icom transmit signal to a level of +20 dBm and allowing it to function as the conventionally higher level local oscillator signal, even though it is a modulated signal. The transmit local

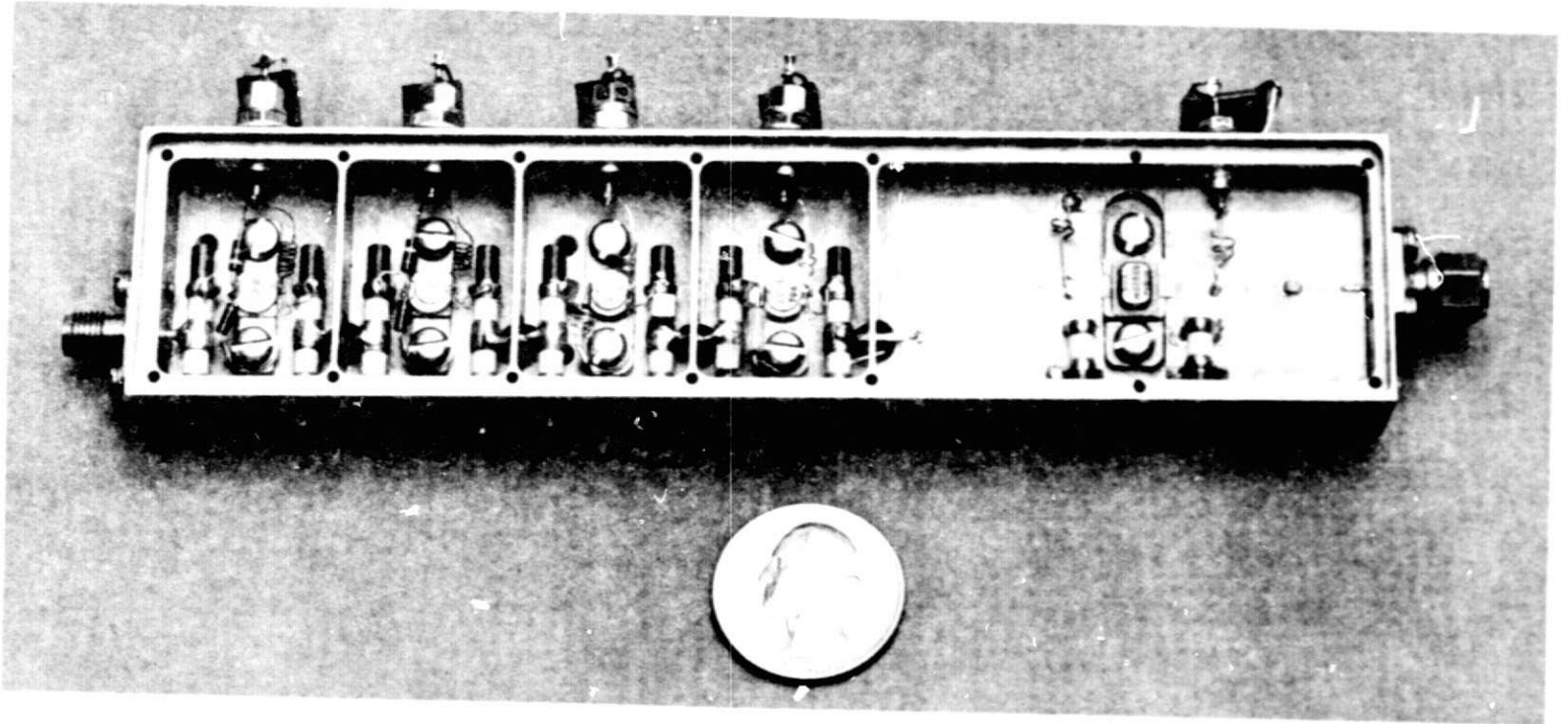

Figure 3. Photograph of the 20 Watt Power Amplifier

oscillator, TLO, output is attenuated to approximately +10 dBm and allowed to function as the lower level signal input into the mixer, even though it is not modulated.

The resultant mixing product at L-band is, therefore, only approximately 8 dB less than the lowest level signal applied to TMIX and is on the order of +2 dBm. The insertion loss of BPF3 reduces this to 0 dBm at the input to the power amplifier.

The attenuator between TLO and TMIX, TBD ATT, is selected during testing as a final level adjustment in order to provide the power amplifier with as close a level to 0 dBm as possible. An assortment of 1, 2, and 3 dB attenuators was purchased for this purpose, since commercial crystal oscillators are generally specified to provide a minimum power output level rather than an exact level, and do in fact have a wide variation in output levels. Commercial oscillators specified for +10 dBm minimum output have been measured at Goddard at levels from +10.5 dBm up to +16 dBm.

Precisely 0 dBm is desirable at the input to the 20 watt power amplifier because this is the input level for which it was optimized, although it will still function adequately for input level variations greater than ± 1 dB.

The final bandpass filter, BPF3, serves to insure that no unwanted signals enter the power amplifier. Here again, filter characteristics are not stringent, since another in-house two pole filter performed the function adequately.

The 20 watt L-band power amplifier was designed, built, and tested within Goddard by L. Line of the RF Technology Branch and utilizes the design and construction techniques used in satellite hardware to achieve a very compact and efficient subsystem. Figure 3 shows a photograph of this amplifier. It employs an output isolator for the protection of the output transistor, draws approximately 30 ma of current from the supply voltage with no signal applied, operates with a DC/RF efficiency of approximately 40% and has been tested over a temperature range of from -30° to $+60^{\circ}\text{C}$. The final stage of the amplifier operates in Class C and approaches the state of the art in power output capability. It requires a +24 volt supply instead of the +15 volt supply used for all other briefcase transceiver subsystems, because the only transistor capable of 20 watts output at L-band is a 24 volt device. Additional information on the amplifier is provided in Table 1.

The DC/DC converter accepts the +11 volt to +15 volt variation in an automobile electrical system and provides the regulated +24 volts required by the power amplifier and the regulated +15 volts required by the other briefcase transceiver subsystems.

Regulation is especially required for the local oscillators since measured frequency variations as a function of supply voltage are greater than 1 kHz/volt, which could cause alignment problems.

ALIGNMENT AND TESTING

Some aspects of the alignment and level setting of the briefcase transceiver have been mentioned already but will be repeated for completeness.

Two level adjustments are required:

1. With a nominal level of receive signal at the briefcase RF port, the attenuation of RATT was selected to allow the signal strength meter of the Icom transceiver to indicate half-scale. A signal from ATS-6 was used for the input signal because no laboratory signal generator of sufficient stability was available.
2. Since the 20 watt power amplifier requires 0 dBm at its input for optimum performance, the output of BPF3 was connected to a power meter (and to a spectrum analyzer to insure that no spurious or harmonics are present) and the attenuation of the "To Be Determined" attenuator, TBD ATT, was selected to provide the 0 dBm required. The level at the L port of TMIX was not used because of the non-linear level relationship between mixer ports L and R.

Two frequency adjustments were made:

1. After a reasonable warm-up period, both of the local oscillators, RLO and TLO, were connected in turn to a laboratory frequency counter and

tuned, by means of the crystal aging adjustment, to 1103.0000 MHz \pm 0.0001 MHz and 1211.0000 MHz \pm 0.0001 MHz, respectively. This facilitates the UHF and L-band frequency identification and transposition.

The L-band frequencies must fall within the satellite transponder bandwidth but otherwise may be arbitrarily selected. A transmit frequency of 1655.100 MHz and a receive frequency of 1552.100 MHz were selected and necessitated the purchase of the appropriate UHF transceiver crystals for 441.100 MHz and 449.100 MHz, respectively. Additional crystals were purchased for other frequencies.

2. Initial frequency alignment of the UHF transceiver was performed in the laboratory according to the procedures outlined in the instruction manual and utilizing a high stability, high resolution UHF generator for the receive mode alignment and a frequency counter for the transmit mode alignment. The final adjustment on the receive adjustment was made during actual satellite tests, with ATS-6 serving as the signal source.

Characterization of the briefcase transceiver by testing was minimal. The regulation of the DC/DC converter under load was briefly checked and the transmit power level at the antenna port was verified at room temperature. Other than the successful operational tests with the satellite, the only additional test

Table 3. Electrical Specifications of the L-Band Voice Transceiver

Transmit	
Power out	20 watts
Frequency range	1655.000 - 1656.000 MHz
Frequency stability	1 part in 10^6
Modulation	Narrowband FM
Audio bandwidth	300 - 3000 Hz
Peak deviation	5 kHz
Pre emphasis	.2 millisecond
Receive	
Noise figure	6.0 dB
Frequency range	1552.000 - 1553.000 MHz
Frequency stability	1 part in 10^6
Audio bandwidth	300 - 3000 Hz
De emphasis	.2 millisecond
IF bandwidth	15 kHz
Power	+11 to +15 volts dc
Temperature	0°C to 50°C

performed was of FM quieting, which was measured to be greater than 35 dB.

This test again utilized the satellite as a signal source and a simple helical antenna with a gain of 9 dB.

A summary of the electrical specifications of the transceiver is shown in Table 3.

PACKAGING

The initial plan was to package the transceiver in a metal enclosure, and heat-sinking and other thermal control techniques were taken into account. The housing that was finally used, a black plastic briefcase, was not analyzed and, therefore, intuition and the high temperature (determined by touch) of some of the briefcase subsystems dictate that the briefcase lid remain fully open during transceiver operation to fully utilize convective cooling.

Denser packaging than that achieved in the briefcase transceiver could be implemented, but not without considerably more machine and sheet metal work.

CCST

The total cost of the components used in the briefcase transceiver is the sum of the small quantity prices shown in Table 1, and is approximately \$5,000 and includes an additional miscellaneous component cost of approximately \$200 to account for such items as RF connectors and attenuators.

To translate this component cost into a manufacturer's selling price, the rule of thumb factor of 2.5 must be applied twice. The component cost of the 20 watt power amplifier, \$1000, must be converted to a manufacturer's selling price of \$2500, and then this number must be substituted for the \$1000 component cost listed for the power amplifier to obtain the realistic total of subsystem costs

which thus becomes \$6500. The final factor of 2.5 is then applied to this amount to estimate the manufacturer's selling price for the complete system and the small quantity selling price becomes approximately \$16,000.

This price refers only to duplicates of the briefcase transceiver produced in small quantities. In order to appreciate the impact of productionization, it must be mentioned that commercial 35 watt transceivers for the 900 MHz land mobile band are presently available for approximately \$1500.

CONCLUSIONS

The briefcase transceiver is obviously a very make-shift, minimally tested and non-optimized device, but it does work well. It has operated with the satellite, ATS-6, many times and a prototype unit, packaged for mobile operation and connected to a simple dipole antenna mounted on an automobile roof, successfully demonstrated good quality mobile/satellite communications through ATS-6. It has fulfilled the purposes for which it was developed and presents a glimmer of the potential of satellite communications and a model upon which further development might be based.

Further effort on this device might include more extensive tests. Further development might include the replacement of the two local oscillators by one oscillator with two switchable crystals and an output diplexer, for the purpose of reducing cost, size, weight, and power drain.

ACKNOWLEDGEMENTS

The authors wish to acknowledge Dr. J. Brown for the initial idea and technical consultation, L. Line for the power amplifier, and J. Cottrell and R. Schnurr for support of the packaging effort.

BIBLIOGRAPHIC DATA SHEET

1. Report No. 78108	2. Government Accession No.	3. Recipient's Catalog No.	
4. Title and Subtitle A Portable L-Band Voice Transceiver for Satellite Communications		5. Report Date	
		6. Performing Organization Code	
7. Author(s) J. Maruschak, D. Nace		8. Performing Organization Report No.	
9. Performing Organization Name and Address Telecommunications Systems Branch Communications & Navigation Division Applications Directorate		10. Work Unit No.	
		11. Contract or Grant No.	
12. Sponsoring Agency Name and Address NASA, Goddard Space Flight Center Greenbelt, Maryland 20771		13. Type of Report and Period Covered	
		14. Sponsoring Agency Code	
15. Supplementary Notes			
16. Abstract A portable L-band voice transceiver was developed as a feasibility model and can provide a half-duplex voice link to another terminal via the L-band transponder on the Applications Technology Satellite, ATS-6. The narrow band FM transceiver utilizes commercial subsystems including a UHF transceiver, provides an RF output power of 20 watts, weighs less than 25 lbs., is housed in a plastic briefcase, can be powered by an automobile electrical system, and has been successfully operated with ATS-6 on numerous occasions. The cost of the transceiver subsystems is approximately \$5000. Design considerations and operation of the transceiver are described, along with alignment and testing procedures, packaging and cost considerations, subsystem performance requirements and overall transceiver performance characteristics.			
17. Key Words (Selected by Author(s)) Satellite Communications, Portable Transceiver		18. Distribution Statement	
19. Security Classif. (of this report)	20. Security Classif. (of this page)	21. No. of Pages	22. Price*