

May, 1978

ESL-TH-821

Research Supported by:

NASA Ames Grant NGL-22-009-124

AFOSR Grant 77-3281

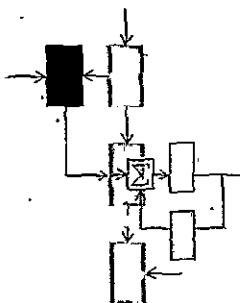

ON RELIABLE CONTROL SYSTEM DESIGNS

John Douglas Birdwell

(NASA-CR-157229) ON RELIABLE CONTROL SYSTEM
 DESIGNS Ph.D. Thesis (Massachusetts Inst.
 of Tech.) 260 p HC A12/NF A01 CSCL 12B

N78-26781

Unclas
G3/63 23298

Electronic Systems Laboratory

MASSACHUSETTS INSTITUTE OF TECHNOLOGY, CAMBRIDGE, MASSACHUSETTS 02139

REPRODUCED BY
 NATIONAL TECHNICAL
 INFORMATION SERVICE
 U. S. DEPARTMENT OF COMMERCE
 SPRINGFIELD, VA. 22161

U.S. DEPARTMENT OF COMMERCE
National Technical Information Service

N78-26781

ON RELIABLE CONTROL SYSTEM DESIGNS

JOHN DOUGLAS BIRDWELL

MASSACHUSETTS INSTITUTE OF TECHNOLOGY
CAMBRIDGE, MASSACHUSETTS

MAY 1978

May, 1978

ESL-TH-821

ON RELIABLE CONTROL SYSTEM DESIGNS

by

John Douglas Birdwell

This report is based on the unaltered thesis of John Douglas Birdwell, submitted in partial fulfillment of the requirements for the degree of Doctor of Philosophy at the Massachusetts Institute of Technology in May, 1978. The research was conducted at the M.I.T. Electronic Systems Laboratory. Stipend and tuition support was from a fellowship from the Fannie and John Hertz Foundation; additional support was from NASA Ames grant NGL-22-009-124 and AFOSR grant 77-3281.

Electronic Systems Laboratory
Massachusetts Institute of Technology
Cambridge, Massachusetts 02139

1

ON RELIABLE CONTROL SYSTEM DESIGNS

by

JOHN DOUGLAS BIRDWELL

B.S., The University of Tennessee
(1974)

M.S., The University of Tennessee
(1974)

SUBMITTED IN PARTIAL FULFILLMENT
OF THE REQUIREMENTS FOR THE
DEGREE OF

DOCTOR OF PHILOSOPHY

at the

MASSACHUSETTS INSTITUTE OF TECHNOLOGY

MAY, 1978

© John Douglas Birdwell 1978

Signature of Author..... *John Douglas Birdwell*
Department of Electrical Engineering, May 18, 1978

Certified by..... *Michael Atham*
Thesis Supervisor

Accepted by.....
Chairman, Departmental Committee on Graduate Students

copyright: John Douglas Birdwell, 1978

The Massachusetts Institute of Technology and the Electronic Systems Laboratory are granted the right to reproduce and distribute this report in its entirety without limitation. All other rights reserved.

ON RELIABLE CONTROL SYSTEM DESIGNS

by

JOHN DOUGLAS BIRDWELL

Submitted to the Department of
Electrical Engineering and Computer Science
on May 18, 1978 in partial fulfillment of the requirements
for the Degree of Doctor of Philosophy.

ABSTRACT

This report contains a method of approach and theoretical framework which advances the state of the art in the design of reliable multivariable control systems, with special emphasis on actuator failures and necessary actuator redundancy levels.

The mathematical model consists of a linear time invariant discrete time dynamical system. Configuration changes in the system dynamics, (such as actuator failures, repairs, introduction of a back up actuator) are governed by a Markov chain that includes transition probabilities from one configuration state to another. The performance index is a standard quadratic cost functional, over an infinite time interval.

If the dynamic system contains either process white noise and/or noisy measurements of the state, then the stochastic optimal control problem reduces, in general, to a dual problem, and no analytical or efficient algorithmic solution is possible. Thus, the results are obtained under the assumption of full state variable measurements, and in the absence of additive process white noise.

Under the above assumptions, the optimal stochastic control solution can be obtained. The actual system configuration can be deduced with an one step delay. The calculation of the optimal control law requires the solution of a set of highly coupled Riccati-like matrix difference equations; if these converge (as the terminal time goes to infinity) one has a reliable design with switching feedback gains, and, if they diverge, the design is unreliable and the system cannot be stabilized unless more reliable actuators or more redundant actuators are employed. For the reliable designs, the feedback system requires a switching gain solution, that is, whenever a system change is detected, the feedback gains must be reconfigured. On the other hand, the necessary reconfiguration gains can be precomputed, from the off-line solutions of the Riccati-like matrix difference equations.

Through the use of the matrix discrete minimum principle, a suboptimal solution can also be obtained. In this approach, one wishes to avoid the reconfiguration of the feedback system, and one wishes to know whether or not it is possible to stabilize the system with a constant feedback gain, which does not change even if the system changes. Once more this can be deduced from another set of coupled Riccati-like matrix difference equations. If they diverge as the terminal time goes to infinity, then a constant gain implementation is unreliable, because it cannot stabilize the system. If, on the other hand, there exists an asymptotic solution to this set of Riccati-like equations then a reliable control system without feedback reconfiguration can be obtained. The implementation requires constant gain state variable feedback, and the feedback gains can be calculated off-line.

In summary, these results can be used for off-line studies relating the open loop dynamics, required performance, actuator mean time to failure, and functional or identical actuator redundancy, with and without feedback gain reconfiguration strategies.

Thesis Supervisor: Michael Athans

Title: Professor of Electrical Engineering and Computer Science

ACKNOWLEDGMENT

I deeply appreciate the guidance and encouragement of my thesis supervisor, Professor Michael Athans. I thank him for the opportunity to observe his unique insight and approach to systems theory.

I thank my readers, Prof. Alan Willsky, Prof. Nils Sandell, and Dr. David Castanon, for their valuable advice. I am especially grateful to Dr. Castanon for the time he spent with me, and for his assistance, in the development of the non-switching gain methodology.

I would like to acknowledge the many hours of discussion with my fellow students, in particular, with Mr. C. Greene, Mr. W.-H. Lee, and Dr. M. Safonov. I would also like to acknowledge Mr. J. Carrig, who wrote the computer routines for this research. A special thanks goes to Dr. Tse-Wei Wang for the many hours she spent helping type this report. Lastly, I thank my parents, Mr. and Mrs. Louis T. Birdwell, for their support and encouragement during the last four years.

This research was conducted at the M.I.T. Electronic Systems Laboratory. Stipend and tuition support was from a fellowship from the Fannie and John Hertz Foundation; additional support was from NASA Ames grant NGL-22-009-124 and AFOSR grant 77-3281.

TABLE OF CONTENTS

| | |
|--|----|
| ABSTRACT | 3 |
| ACKNOWLEDGMENT | 5 |
| TABLE OF CONTENTS | 6 |
| LIST OF FIGURES | 10 |
| LIST OF TABLES | 11 |
| 1. INTRODUCTION | 12 |
| 1.1 Motivation for the Research. | 12 |
| 1.2 General Nature of the Problem. | 13 |
| 1.2.1 Reliability Theory. | 13 |
| 1.2.2 Control Theory. | 22 |
| 1.2.3 General Nature of Results. | 27 |
| 1.3 Relations with Previous Literature. | 29 |
| 1.4 Summary of Main Contributions. | 35 |
| 1.5 Outline of Report. | 36 |
| 2. CLARIFICATION AND MOTIVATION OF RESEARCH | 38 |
| 2.1 Introduction. | 38 |
| 2.2 A Simple Example--The Optimal Solution. | 39 |
| 2.2.1 Problem Statement. | 39 |
| 2.2.2 Summary of Solution. | 41 |
| 2.3 The Dual Control Effect. | 43 |
| 2.3.1 A Special Case. | 46 |
| 2.4 Existence of a Steady-State Solution. | 48 |
| 2.5 Conclusions on the Switching Gain Methodology. | 49 |
| 2.5.1 Implications of the Dual Control Effect. | 50 |
| 2.5.2 Existence of a Steady-State. | 50 |

| | | |
|-------|--|-----|
| 2.6 | A Simple Example--The Non-Switching Solution. | 52 |
| 2.6.1 | Problem Statement. | 53 |
| 2.6.2 | Summary of Solution. | 54 |
| 2.7 | Existence of a Steady-State Solution and the Uncertainty Threshold Principle. | 56 |
| 2.7.1 | Formulation of Existence Problem. | 56 |
| 2.7.2 | Summary of Solution. | 57 |
| 2.7.3 | Graphical Illustration of Solution. | 59 |
| 2.7.4 | Best Control with Infinite Cost. | 61 |
| 2.7.5 | Conclusion. | 66 |
| 2.8 | Summary. | 66 |
| 3. | THE SWITCHING GAIN SOLUTION | 68 |
| 3.1 | Introduction. | 68 |
| 3.2 | Mathematical Formulation. | 70 |
| 3.3 | The Switching Gain Solution. | 72 |
| 3.4 | Discussion of Results. | 74 |
| 3.5 | Examples. | 78 |
| 3.6 | Summary. | 86 |
| 4. | EXTENSIONS TO THE STOCHASTIC CASE | 87 |
| 4.1 | Introduction. | 87 |
| 4.2 | Hypothesis Testing Identification. | 88 |
| 4.3 | Dual Identification. | 90 |
| 4.4 | Examples. | 94 |
| 4.5 | Summary. | 100 |
| 5. | THE NON-SWITCHING GAIN SOLUTION | 101 |
| 5.1 | Introduction. | 101 |
| 5.2 | Problem Statement. | 103 |
| 5.3 | Problem A. | 104 |

| | | |
|---------|--|-----|
| 5.4 | The Method of Solution. | 106 |
| 5.5 | The Necessary Conditions. | 111 |
| 5.6 | Problem B: The Non-Switching Solution. | 114 |
| 5.7 | Stability and the Steady-State Solutions. | 119 |
| 5.7.1 | Stability and Cost-Stability. | 119 |
| 5.7.2 | Definition of the Infinite-Time Cost. | 120 |
| 5.7.3 | Bounded Cost and Mean-Square Stability. | 121 |
| 5.7.4 | Cost-Stability. | 121 |
| 5.7.5 | Equivalence of Problems AE and B. | 122 |
| 5.7.6 | The Steady-State Solution. | 123 |
| 5.7.6.1 | Steady-State Solution to Problem AE. | 124 |
| 5.7.6.2 | Steady-State Solution to Problem B. | 125 |
| 5.7.7 | The Possibility of Limit Cycles. | 126 |
| 5.8 | Equality of \underline{G}_{ns} and \underline{G}^* | 127 |
| 5.9 | Robustness. | 130 |
| 5.10 | Examples. | 132 |
| 5.11 | Summary. | 141 |
| 6. | COMPUTER-AIDED DESIGN | 143 |
| 6.1 | Introduction. | 143 |
| 6.2 | The Design Decision. | 143 |
| 6.3 | A Trade-Off of System Performance Versus Reliability. | 163 |
| 6.4 | Summary. | 173 |
| 7. | CRITIQUE | 174 |
| 7.1 | Introduction. | 174 |
| 7.2 | The Switching Gain Solution. | 174 |
| 7.2.1 | Deterministic Optimal Solution. | 175 |
| 7.2.2 | Non-Extendability to Stochastic Systems. | 175 |
| 7.2.3 | Suboptimal Extensions. | 176 |

| | | |
|------------------------|---|-----|
| 7.3 | The Non-Switching Gain Solution. | 178 |
| 7.3.1 | The Necessary Conditions--Unsolvability. | 178 |
| 7.3.2 | The Equivalent Problem. | 178 |
| 7.3.3 | Existence of a Stabilizing Gain. | 179 |
| 7.3.4 | Problems with Convergence. | 179 |
| 7.3.5 | Existence of a Robust Gain. | 180 |
| 7.4 | Computer-Aided Design. | 182 |
| 7.5 | Suggestions for Future Research. | 185 |
| 7.6 | Summary. | 187 |
| APPENDICES | | 189 |
| Appendix to Chapter 1. | | 190 |
| Appendix to Chapter 2. | | 192 |
| A2.1 | Exact Optimal Solution for Deterministic Case, Chapter 2, Section 2. | 193 |
| A2.2 | Exact Optimal Solution for Stochastic Case, $T = 0, 1, 2 = T_f$. (1-d example). | 194 |
| A2.3 | Exact Solution of Stochastic Case Over $T = 0, 1,$ $2 = T_f$ for a Specific Form of $\rho(\xi)$, Chapter 2, Section 2.3.1. | 199 |
| A2.4 | Existence of Steady-State Solution for 1-d Example. | 202 |
| Appendix to Chapter 3. | | 206 |
| A3.1 | Proof of Theorem 1. | 207 |
| A3.2 | Optimal Solution for Deterministic Problem. | 208 |
| A3.3 | Proof of Lemma 1. | 211 |
| Appendix to Chapter 5. | | 213 |
| A5.1 | Proof of Theorem 1, Chapter 5. | 214 |
| A5.2 | Proof of Remark on Theorem 1, Chapter 5. | 216 |
| A5.3 | Proof of Theorem 2, Chapter 5. | 217 |
| A5.4 | Proof of Theorem 3, Chapter 5. | 219 |
| A5.5 | Proof of Lemma 2, Chapter 5. | 220 |
| A5.6 | Proof of Lemma 3, Chapter 5. | 221 |
| A5.7 | Proof of Theorem 4, Chapter 5. | 222 |
| COMPUTER ROUTINES | | 223 |
| LIST OF REFERENCES | | 256 |

LIST OF FIGURES

| | | |
|------|---|-----|
| 1.1 | Exponential failure distribution. | 16. |
| 1.2 | Typical hazard rate function for a transistor. | 17 |
| 1.3 | Three hypothetical system structures. | 20 |
| 1.4 | Configuration for structures in Figure 1.3. | 21 |
| 1.5 | Two possible structural trajectories. | 23 |
| 2.1 | A probability distribution for amplitude-limited white noise. | 47 |
| 2.2 | $ a _{\text{threshold}}$ versus p, b . | 60 |
| 2.3a | h versus p, b . | 62 |
| 2.3b | h versus p, b . | 63 |
| 2.4 | g versus p, b . | 65 |
| 3.1 | The switching gain control law. | 75 |
| 3.2 | Markov transition probabilities for Example 3.1. | 79 |
| 5.1 | Markov transition probabilities for Example 5.2. | 137 |

LIST OF TABLES

| | |
|--|-----|
| 2.1 The optimal control u_0^* versus x_0 and \bar{E} . | 45. |
|--|-----|

CHAPTER 1

INTRODUCTION

1.1 Motivation for the Research.

This report addresses some of the current problems in interfacing systems theory and reliability, and puts this research in perspective with the open questions in this field. Reliability is a relative concept; it is, roughly, the probability that a system will perform according to specifications for a given amount of time. The motivating question behind this report is: What constitutes a reliable system?

Knowledge of the reliability of a system is crucial. In this report, a system is reliable if it has a (quantitative) reliability of one, i.e., if the probability that the system will not perform according to specifications for a given period of time is zero. Therefore, the question "What constitutes a reliable system?" can be restated as: What are the specifications which a system must meet in order to be reliable?

A system is normally designed in two stages: First, the components are selected in such a way as to meet the reliability specifications; second, the control problem is formulated and solved for that configuration of components. Although this procedure is over-simplified, it illustrates a second question: Should the control problem influence the choice of the configuration, and if so, how can this be achieved? The first part of the question is answered by history: The control problem influences configuration design now by iteration between the two stages of design. This is most likely not the best method! If a theory were

available which allowed a comparison between alternate designs, based on both the expected system reliability and the expected system performance, it would greatly simplify the current design methodology. It is unfortunate that at present there is no accepted methodology for a determination of expected system performance which accounts for changes in the performance characteristics due to failure, repair or reconfiguration of system functions. This report presents such a methodology for a specific class of linear systems with quadratic cost criteria.

1.2 General Nature of the Problem.

This Section presents the general theoretical framework necessary to approach the problem of reliable control system design. First, a discussion of some of the concepts in reliability theory will be presented. The control-theoretic framework for the specific topics covered in this report will then be developed. Finally, the interrelationships between systems theory and reliability theory will be explored, leading to a mathematical formulation of the reliable control system design problem and a discussion of the general nature of the results presented in the remainder of this report.

1.2.1 Reliability Theory.

The generally accepted definition of reliability is stated in Appendix 1. Basically, the reliability of a system is the probability that the system will perform according to specifications for a given amount of time. In a system-theoretic context, the specification which a system must meet is stability; also, since, at least for most mathematical models of systems, stability is a long-term attribute of the system,

the amount of time for which the system must remain stable is taken to be infinite. Therefore, the following definitions of system reliability are used in this report:

Definition 1: A system (implying the hardware configuration, or mathematical model of that configuration, and its associated control and estimation structure) has reliability r where r is the probability that the system will be stable for all time.

Definition 2: A system is said to be reliable if $r = 1$.

Definition 3: A system design, or configuration, is reliable if it is stabilizable with probability one.

These definitions of reliability depend on the definition of stability, and for systems which can have more than one mode of operation, stability is not that easy to determine. In this report, stability will mean either mean-square stability (over some random space which will be left unspecified for the moment), or cost-stability (again, an expectation over a certain random space), which is basically the property that the accumulated cost of system operation is bounded with probability one. (The definition of cost is also deferred.)

The reliability of a system will depend on the reliabilities of its various components and on their interconnections. Thus, the systems engineer must have an understanding of the probabilistic mechanisms of component failure, repair, and system reconfiguration. There are a multitude of models which can be used for component failure and repair, and reconfiguration. Two good references to the mechanics of reliability

theory are [Shooman, 1] and [Green and Bourne, 2].

Consider a device which begins operation at time 0 and can experience catastrophic (i.e., instantaneous) failure to a non-operational state. Let the probability of failure of this device occurring in the interval $[0,t]$ be

$$F(t) = \text{prob. of failure in } [0,t] \quad (1.2.1)$$

This is the definition of the failure distribution function [Shooman, 1].

Define the hazard rate as

$$z(t) = \frac{\frac{dF(t)}{dt}}{1 - F(t)} \quad (1.2.2)$$

from [Shooman, 1]. The hazard rate is the incremental failure probability at time t , given that the device is operational at time t . Now, suppose the hazard rate of the device is independent of time; i.e., the probability that the device will fail sometime in a time interval starting at the present time is independent of how long the device has been operational. This constant hazard rate

$$z(t) = c \quad (1.2.3)$$

results in the exponential failure distribution shown in Figure 1.1.

The constant hazard rate is a close approximation to the actual hazard rate of many devices. For example, the transistor has a hazard rate similar to that shown in Figure 1.2. This type of function is quite common [Shooman, 1]. Early failures in Region I of Figure 1.2 are failures during the "burning-in" of the device; they are associated with poor assembly, defective materials and other random fluctuations in the manufacturing process. Failures in Region III are due to the wearing out of elements in the part. Region II is relatively constant and closely

approximates the constant hazard rate function. In a large system, parts are generally "burned-in" before assembly is completed; therefore, the system begins operation in Region II. As the system ages, periodic maintenance removes old parts before the hazard rate rises in Region III. Therefore, the assumption of a constant hazard rate is usually justified. In this report, the constant hazard rate function is used exclusively. This is due not only to its broad applicability, but also to the fact that any non-constant hazard rate requires a reliable control system to keep track of the starting times of the system's mode of operation.

In the discrete-time case, to which this report is confined exclusively, the hazard rate becomes the probability of failure (or repair or reconfiguration) between time t and time $t+1$. For a system with many operating modes, the probability of being in a given mode at a given time, given some past probability vector over the various operating modes, can be modeled by a Markov chain. If $\underline{\pi}_t$ is a vector

$$\underline{\pi}_t \in \mathbb{R}^{L+1} \quad (1.2.4)$$

where there are $L+1$ operating modes, then $\underline{\pi}_t$ is propagated in time by

$$\underline{\pi}_{t+1} = \underline{P} \underline{\pi}_t \quad (1.2.5)$$

where

$$\underline{P} = (p_{ij}) \in \mathbb{R}^{L+1 \times L+1} \quad (1.2.6)$$

and

$$p_{ij} = \text{prob. of system being in mode } i \text{ at time } t+1, \text{ given it was in mode } j \text{ at time } t \quad (1.2.7)$$

(see [Paz, 3]). The probability p_{ij} is the discrete-time equivalent of the hazard rate, and is time-invariant. In the future, a time-invariant Markov chain will be assumed as a model of the modes of operation

and the statistics of the random switchings between modes.

It is now necessary to define precisely these modes of operation and their dynamic transitions. The terms system configuration and system structure will be used.

Definition 4: System Structure: A possible mode of operation for a given system; the components, their interconnections, and the information flow in the system at a given time.

Definition 5: System Configuration: The original design of the system, accounting for all modeled modes of operation, and the Markov chain governing the configuration, or structural, dynamics (transitions among the various structures).

An example of three possible structures for a given system is shown graphically in Figure 1.3. In this report, structures are referenced by convention by the set of non-negative integers

$$I = \{0,1,2,3,\dots,L\} \quad (1.2.8)$$

The configuration for the design illustrated in Figure 1.3 is depicted graphically in Figure 1.4. The nodes of the graph in Figure 1.4 represent the system structures of Figure 1.3. The edges of the graph represent probabilities of transfer from one node to another, and are elements of the matrix P.

$$P_{i+1,j+1} = \begin{array}{l} \text{prob. structure } i \text{ at time } t+1 \text{ given structure } j \text{ at} \\ \text{time } t. \end{array} \quad (1.2.9)$$

The state of the system configuration at time t is the structure in which the system is operating at that time.

76265AW018

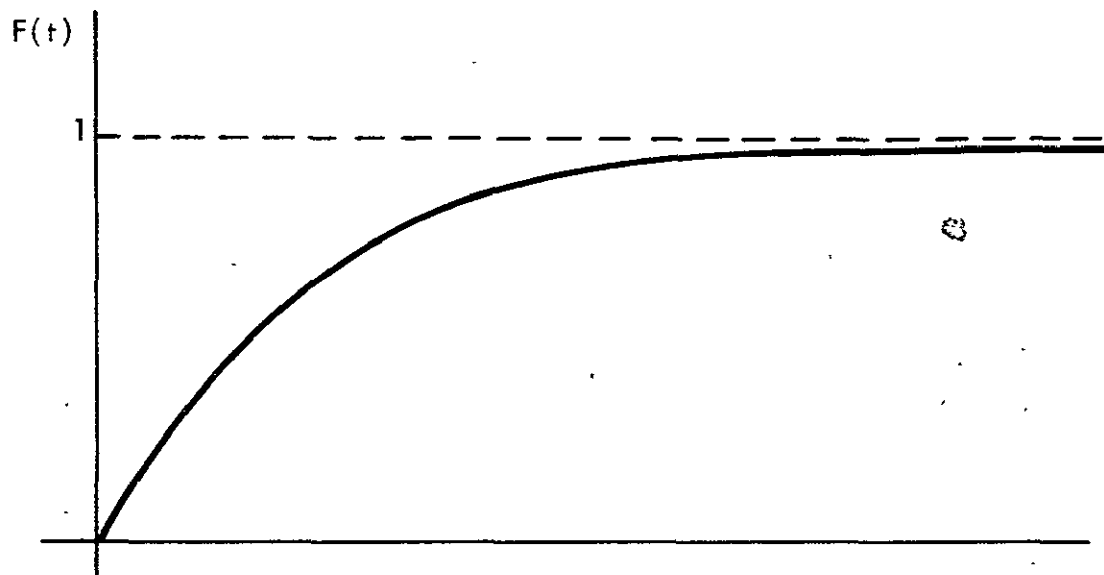

Figure 1.1: Exponential failure distribution.

76265AW019

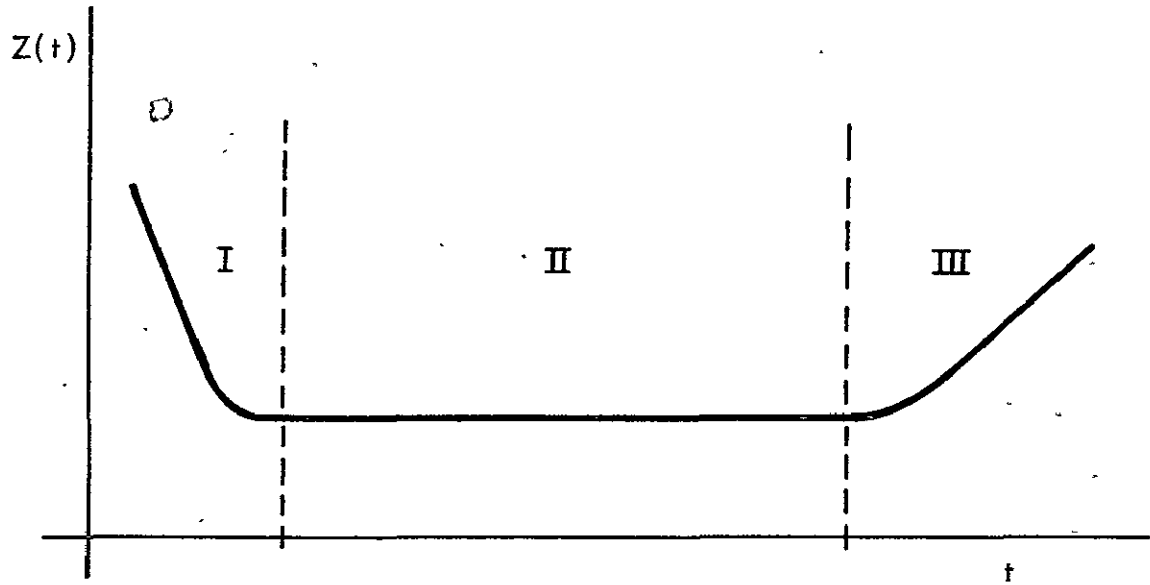

Figure 1.2: Typical hazard rate function for a transistor.

76265AW020

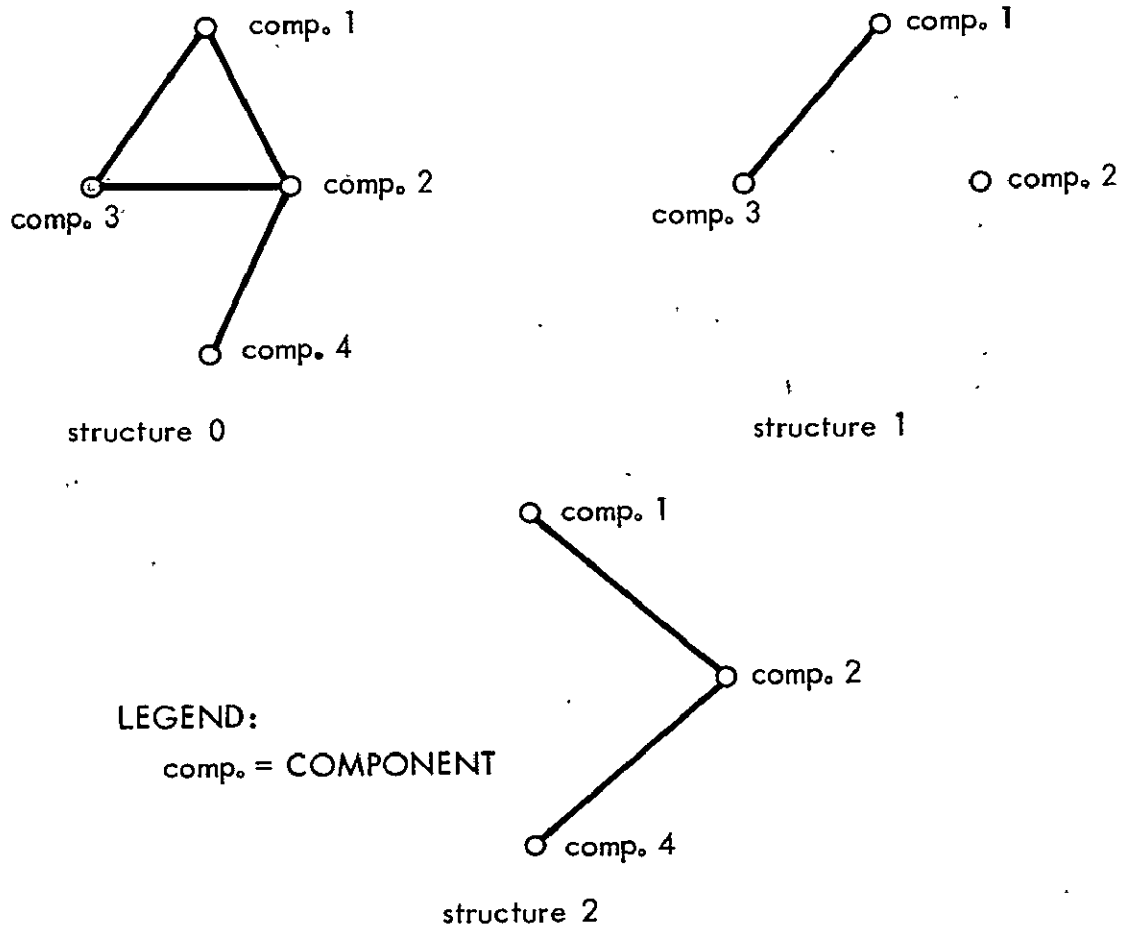

Figure 1.3: Three hypothetical system structures.

76265AW021

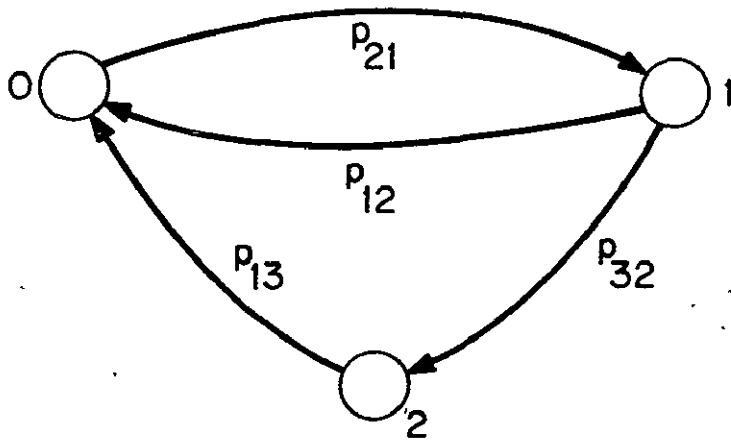

Figure 1.4: Configuration for structures in Figure 1.3.

$$k(t) = \text{structural state at time } t \quad (1.2.10)$$

$$k(t) \in I \quad (1.2.11)$$

This structural state evolves in time to form the structural trajectory (of length $T+1$)

$$\bar{x}_T = (k(0), k(1), \dots, k(T)) \quad (1.2.12)$$

In general, this structural trajectory is a random variable with apriori probability of occurrence

$$p(\bar{x}_T) = \pi_{k(0),0} \cdot p_{k(1)k(0)} \cdot p_{k(2)k(1)} \cdots p_{k(T)k(T-1)} \quad (1.2.13)$$

(Figure 1.5).

1.2.2 Control Theory.

In this report, only linear systems with a quadratic cost index are considered. At this time, any more general formulation is of dubious value in that the linear quadratic problems can demonstrate many of the fundamental concepts of reliable control system design. It is doubtful that any other formulation could be solved without the knowledge gained from the linear quadratic solutions presented in the remainder of this report. As a further restriction, perfect observation of the system state \underline{x}_t is assumed. The general class of linear systems discussed in this report is of the form

$$\underline{x}_{t+1} = \underline{A}_{k(t)} \underline{x}_t + \underline{B}_{k(t)} \underline{u}_t \quad (1.2.14)$$

The set of pairs $(\underline{A}_k, \underline{B}_k)$ describe the possible system structures,

where

$$k(t) \in I \quad (1.2.15)$$

The remainder of the configuration is specified by the Markov chain equation (1.2.5). The objective of this research is to develop control

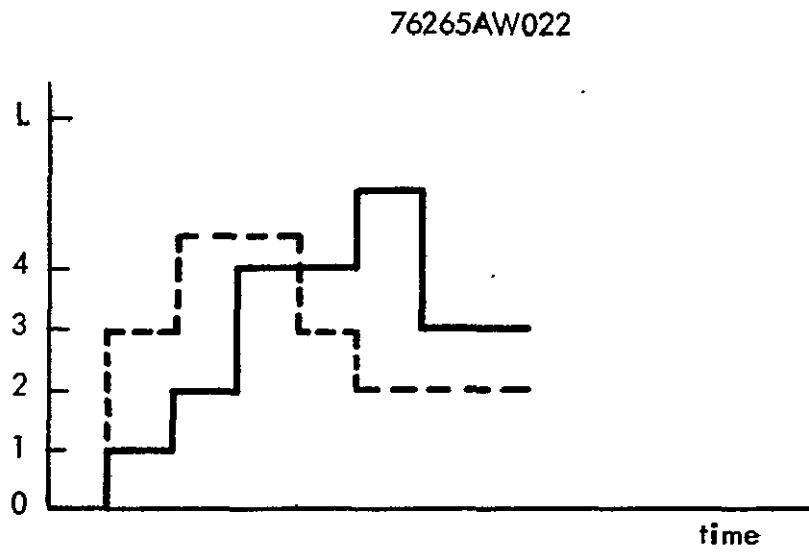

Figure 1.5: Two possible structural trajectories.

laws which account for the possible structural trajectories (1.2.12) while minimizing some function of the cost. The cost function for a given random state and control trajectory $((\underline{x}_t, \underline{u}_t)_{t=0}^{T-1}, \underline{x}_T)$ is

$$J_T = \sum_{t=0}^{T-1} \underline{x}_t^T \underline{Q} \underline{x}_t + \underline{u}_t^T \underline{R} \underline{u}_t + \underline{x}_T^T \underline{Q} \underline{x}_T \quad (1.2.16)$$

The function of the cost which is minimized is generally taken to be the expected value of J_T over all possible structural trajectories $\bar{\underline{x}}_T$. It is shown that this class of optimization problems yields solutions which are sensitive to both system performance and system reliability, as modeled in the configuration.

In the remainder of the report, only variations in the B-matrix, or actuators are considered. An actuator is a device which transfers the control input to the system dynamics. The actuator in the B-matrix may model a physical linkage, such as is found on the control surfaces of aircraft, or, for example, the effectiveness of a tax reduction on the economy. A single actuator may fail in many different modes. For example, the B-matrix can be of the form

$$\underline{B}_0 = [\underline{b}_0 \mid \underline{b}_1 \mid \cdots \mid \underline{b}_J] \quad (1.2.17)$$

where the \underline{b}_i 's are actuators which may fail to an actuator having zero gain with a failure probability per unit time p_f :

$$\underline{b}_i \rightarrow \underline{0} \quad (1.2.18)$$

Then the system structures representing modes of failure would be modeled as B-matrices having at least one zero column.

This class of linear models can also be used as a model for self-reorganizing systems; the only restriction is that the reorganization, or reconfiguration, process must be modeled with a constant hazard rate.

An important aspect of this research is the study of various types of redundancy. At present, the effect of redundancy on system performance is poorly understood. There are two basic types of redundancy: component redundancy and functional redundancy. Component redundancy is the use of two or more identical components (in this report, actuators) for the same task. A good example is provided by equation (1.2.17). Suppose two actuators, \underline{b}_i and \underline{b}_j , are identical. If \underline{b}_i fails (Equation (1.2.18)), \underline{b}_j is still operational, and vice-versa. In order to lose the function of actuators \underline{b}_i and \underline{b}_j , both actuators must fail; this event will have a lower probability of occurrence than the event of the failure of \underline{b}_i ; if \underline{b}_j were not in the configuration the function of actuator \underline{b}_i would be lost.

The problem with component redundancy in control theory is how should the allocation of control resources be allocated to the redundant components, and how should the component reliabilities affect the choice of an optimal control law? The control methodologies presented in this report answer the question for a specific class system configurations.

Functional redundancy implies the overlapping of function of two or more components in a system. If one of the components fails, part of its function is still performed by the other (redundant) component(s). Functionally redundant actuators are modeled in this report in the same way as component redundancy. The functional redundancy is accounted for in the expectation of the cost index over the structural trajectories.

The dynamics of repair and reconfiguration are all modeled in this report as exponential failure distributions (constant hazard rates).

As an example, if two actuators (\underline{b}_0 and \underline{b}_1) are in a system configuration and can each fail with probability p_{f_0} and p_{f_1} per unit time, respectively, to an actuator with zero gain ($\underline{0}$), then the configuration dynamics are, assuming independence of failures:

$$\underline{B}_0 = [\underline{b}_0 \mid \underline{b}_1] \quad (1.2.19)$$

$$\underline{B}_1 = [0 \mid \underline{b}_1] \quad (1.2.20)$$

$$\underline{B}_2 = [\underline{b}_0 \mid 0] \quad (1.2.21)$$

$$\underline{B}_3 = [0 \mid 0] \quad (1.2.22)$$

$$\underline{B}_0 \rightarrow \underline{B}_1 \quad \text{with probability } p_{f_0}(1-p_{f_1}) \text{ per unit time} \quad (1.2.23)$$

$$\underline{B}_0 \rightarrow \underline{B}_2 \quad \text{with probability } p_{f_1}(1-p_{f_0}) \text{ per unit time} \quad (1.2.24)$$

$$\underline{B}_0 \rightarrow \underline{B}_3 \quad \text{with probability } p_{f_0}p_{f_1} \text{ per unit time} \quad (1.2.25)$$

$$\underline{B}_1 \rightarrow \underline{B}_3 \quad \text{with probability } p_{f_1} \text{ per unit time} \quad (1.2.26)$$

$$\underline{B}_2 \rightarrow \underline{B}_3 \quad \text{with probability } p_{f_0} \text{ per unit time} \quad (1.2.27)$$

From this information, the Markov chain transition matrix \underline{P} can be formed:

$$\underline{P} = \begin{bmatrix} 1-p_{f_0}-p_{f_1}+p_{f_0}p_{f_1} & 0 & 0 & 0 \\ p_{f_0}(1-p_{f_1}) & 1-p_{f_2} & 0 & 0 \\ p_{f_1}(1-p_{f_0}) & 0 & 1-p_{f_1} & 0 \\ p_{f_0}p_{f_1} & p_{f_2} & p_{f_1} & 1 \end{bmatrix} \quad (1.2.28)$$

Repair is considered to be component replacement, and is modeled in the same manner; e.g.,

$$\underline{0} \rightarrow \underline{B}_0 \quad \text{with probability } p_{r_1} \cdot p_{r_2} \quad (1.2.29)$$

Reconfiguration is the restructuring of the (actuator) configuration to compensate for failure, and is modeled as

$$\underline{B}_1 \rightarrow \underline{B}_4 \quad \text{with probability } p_{41} \quad (1.2.30)$$

where \underline{B}_4 is a new actuator configuration which will be used on reconfiguration after failure.

The methodologies presented allow the study of the effects of failure, repair and reconfiguration on the optimal control of linear systems; they yield a quantitative analysis of the effectiveness of a given system design, where effectiveness is a quantity relating both the performance and the reliability of a configuration design (see Appendix 1).

1.2.3 General Nature of Results.

There are three classes of reliable controller methodologies:

- I) Passive (Robust) Controller Design
- II) Active (Switching) Controller, Passive Configuration Design
- III) Active Controller, Active Configuration Design

This report concentrates entirely on classes I) and II). Class III) methodologies are much more difficult to study. The Markov chain models of configuration dynamics which work in classes I) and II) do not hold in class III); as yet, there is no satisfactory way to model the configuration dynamics of a system in such a way that the control rules are well-defined.

Class I) methodologies are passive designs. These designs account for the occurrence of failures in the initial selection of the control law; on-line, this class of designs does not use any current estimate of the structural state of the configuration. The design is "conservative"

in that it continues to stabilize the system without regard to the current structural state. A special sub-class of these designs is the robust controller designs. A robust controller will stabilize any structure of the system without regard to the configuration dynamics; i.e., if the system remains in any structural state forever, it will still be stabilized. The class I) methodologies are represented by the non-switching gain methodology of Chapter 5.

Class II) methodologies are active controllers; in some sense, they are adaptive. From knowledge of the system's past, these controllers switch their control law on-line in order to compensate for what they estimate to be the correct structural state. For deterministic systems, these controllers can be determined analytically. For stochastic systems, the optimization problems cannot be solved analytically in general due to the dual control effect [Fel'dbaum, 4- 7]. Thus, suboptimal control strategies must be used. The class II) methodologies are represented by the switching gain methodology in Chapter 3 and its suboptimal extensions in Chapter 4.

1.3 Relations with Previous Literature.

This research is based on a background knowledge in both reliability theory and systems theory. Both mathematics and probability theory are fundamental in these fields. As general references to the techniques used in this report, in real analysis, and measure and integration theory, [Rudin,8], [Segal & Kunze, 9], and [Halmos,10] are good; in matrix theory, [Gantmacher,11] is the standard reference. In probability theory, [Bauer,12] and [Doob,13] are definitive; expansions on the theory of Markov chains are found in [Chung,14] and [Derman,15].

There are several good texts on reliability theory; of these, [Greene & Bourne, 2] and [Shooman, 1] are possibly the best. [Cox,16] and [Corcoran,17] demonstrate the current methods of the scheduling and use of redundancy in reliability technology. Other good treatments are found in [Barlow and Proschan,18] and [Gnedenko,19].

In control theory, a good treatment of the deterministic linear quadratic regulator problem is found in the IEEE Transactions Special Issue edited by [Athans,20], and in [Athans & Falb,21]. The dual control problem is described in [Fel'dbaum, 4- 7] and several other publications.

Previously, several authors have studied the optimal control of systems with randomly varying structure. Most notable among these is [Wonham,22], where the solution to the continuous time linear regulator problem with randomly jumping parameters is developed. This solution is similar to the discrete time switching gain solution presented in Chapter 3. The random parameters are restricted to be a continuous time Markov chain. The most notable difference is that in [Wonham,22],

the assumption is made that the controller has perfect information about the present state of the random process on-line. The solution switches gains in a linear state feedback control law whenever the (Markovian) random parameter jumps. In the discrete time switching gain solution presented in Chapter 3, the control law is determined from past observations which allow the deduction of the exact state of the random parameter process, and then the random parameter may switch values according to the statistics given by the Markov chain. Thus, the control may be applied to one of a number of possible structures at the next time instant. In Wonham's development, the optimal control law is matched specifically to one structure. The analogous continuous time version to the switching gain solution of Chapter 3 would be to assume on-line perfect observation of the random parameter with a fixed time delay. Wonham's result has no such time delay.

Wonham also proves an existence result for the steady-state optimal solution to the control of systems with randomly varying structure. This result is based on conditions of stabilizability of each system structure and observability of each structure with respect to the cost functional. The conclusion is only sufficient; it is not necessary for existence of a steady-state solution. Similar results were obtained in [Beard,23] for the existence of a stabilizing gain, where the structures were of a highly specific form; these results were necessary and sufficient algebraic conditions, but cannot be readily generalized to less specific classes of problems.

The time-varying solution of [Wonham,22] is computed using a set of coupled Riccati-like matrix equations. The coupling is in the form of

a linear term in the solution to the matrix equations added to the normal linear quadratic Riccati equation. The solution can be precomputed by solving the coupled Riccati-like equations off-line; the control law is then switched on-line to a gain which corresponds to the current state of the Markov process. The optimal solution requires perfect knowledge of the structure.

In reality, the structure is seldom known perfectly, and a noisy observation of the random process leads to a dual control problem. Although much of Chapter 3 is based on the fact that the controller can obtain the structural state with one-step delay in the deterministic discrete time problem, this report makes the connection, for the first time, of the existence of a steady-state switching gain controller with that system's reliability and effectiveness.

[Sworder, 24] has developed, using a version of the stochastic maximum principle, an optimal feedback control law for a class of linear systems with jump parameters which is almost identical to that of [Wonham, 22]; the coupled Riccati-like equations are identical except for notation. The only difference is Sworder's assumption that the random process is instantaneously observable from a set of sensors which are unaffected by the choice of the control law. Using this assumption, Sworder avoids the problems of dual control.

Sworder also comments on the usefulness of linear system models with jump parameters in modeling possible failures in the system [Sworder, 24]. [Ratner & Luenberger, 25] derive a control law for a continuous time linear system. The system has one failure mode, and a maximum number of renewals (repairs) can take place. The objective is

to determine apriori the optimal time intervals in which the system should operate in the failure mode, and the optimal control law, given the mode of operation, over a finite time interval. The failure process is assumed to have an exponential failure distribution (constant hazard rate); the renewal process is controlled, and is not random. The control law is of the switching gain type, and the solution is in the form of two coupled Riccati-like matrix equations quite similar to those in [Wonham,22] and [Sworder,24]. The optimal control policy and the optimal renewal policy can both be calculated off-line. This class of problems is further investigated by [Sworder,26] to determine over what region immediate renewal is the optimal policy. Both of these papers illustrate examples of class III) control methodologies; the structural state as well as the system state is under the influence of the controller. The simple structure of the class of systems studied by [Ratner & Luenberger,25] allows a solution. There is need for much more work in this area.

Still a third approach to the problems associated with multiple-structure systems is given in [Bar-Shalom & Sivan,27]. Here, the measurements of the system state are corrupted by additive noise. The open-loop controller and the open-loop feedback controller are derived using dynamic programming. Knowledge of the present state of the random process governing the system configuration is not assumed. Therefore, the (optimal) closed-loop controller would be a dual control law. The open-loop controller assumes no on-line measurements of the system state; the open-loop feedback controller assumes future on-line measurements and thereby improves its performance. There is little correlation

between this paper and the research on which this report is based.

[Willner,28] developed a suboptimal control scheme, which allowed for imperfect observation of the random parameter process, known as multiple-model adaptive control. In this method, the parameters could only take a discrete set of values, a cause of recent disfavor, as MMAC does not always work well when the parameters vary continuously and are approximated by the mathematics. Similar work has been done in [Pierce & Sworder,29]. The MMAC methodology is optimal one step backward from the final time, as is the switching gain methodology in the example of Chapter 2 when applied to systems with additive white control noise.

The dual problem of state estimation with a system with random parameter variations over a finite set was studied in [Chang & Athans,30]. It is shown there that the optimal estimator consists of a geometrically increasing set of Kalman filters, one for each possible structural trajectory of length $t+1$ at time t , and an averaging process to compute the minimum mean-square error estimate from the filter estimates. It is also shown that when the parameter process is Markovian, a bank of N^2 estimators is optimal, where there are N possible values of the parameters. Each estimator is then conditioned on the possible values of the parameters at the two previous time instants.

Recently, the robustness of the linear quadratic regulator has been studied in depth. This work is described in [Wong, et. al.,31] and in [Safonov & Athans,32]. A long-standing problem with the linear quadratic design methodology has been the lack of analogs to the various stability and robustness criteria of classical systems theory. This research was aimed at characterizations of robust solutions to,

specifically, the linear quadratic regulator. Supporting research is reported in [Safonov & Athans,33], [Wong & Athans,34], [Wong,35], and [Safonov,36]. The research in this report is related to the robust controller problem, but the approach is different in that the performance criterion is modified to account for possible variations in structure, such as those caused by failures, rather than depending on certain properties of the linear quadratic regulator solution to guarantee robustness. In this research, the concept of stability is related to the existence of a finite cost solution to the non-switching gain problem. For a specific class of configurations, this approach solves the robust controller problem (Chapter 5, Section 9).

The existence of an uncertainty threshold for the non-switching controller of Chapter 5, that limit on parameter uncertainty beyond which no controller can stabilize the system, is proven for an one-dimensional example. This work is similar to the work by [Athans, et. al.,37] on the Uncertainty Threshold Principle and the related papers by [Ku & Athans,38] and [Ku, et. al.,39]. This research is reported in Chapter 2, Section 7.

Lastly, parts of this research have been presented in an unpublished form at the 1977 Joint Automatic Control Conference in San Francisco, and published for the 1977 IEEE Conference on Decision and Control Theory in New Orleans [Birdwell & Athans,40].

1.4 Summary of Main Contributions.

There are two major contributions of this research. First, the classification of a system design as reliable or unreliable, for the deterministic variable actuator linear system in Chapter 3, has been equated with the existence of a steady-state switching gain and cost for that design. If the steady-state switching gain does not exist, then the system design cannot be stabilized; hence, it is unreliable. The only recourse in such a case is to use more reliable components and/or more redundancy. Reliability of a system design can therefore be determined by a test for convergence of the set of coupled Riccati-like equations (3.3.6) as the final time goes to infinity.

A similar result holds for the non-switching gain methodology of Chapter 5. Here, the system design is classified as reliable or unreliable with respect to a constant gain linear feedback control law, depending on the convergence, or divergence, respectively, of equation (5.6.16) as the final time goes to infinity. If equation (5.6.16) converges to a limit cycle, then that limit cycle produces a stabilizing cyclic steady-state gain.

The second major contribution lies in the robustness implications of the non-switching gain methodology. Precisely, a constant gain for a linear feedback control law for a set of linear systems is said to be robust if that gain stabilizes each linear system individually, i.e., without regard to the configuration dynamics. The problem of determining when such a gain exists, and of finding a robust gain, can be formulated in the context of the non-switching gain methodology. As a result, the non-switching gain methodology gives an algorithm for determining a

robust gain for a set of linear systems which is optimal with respect to a quadratic cost criterion. If the algorithm does not converge, then no robust gain exists.

The following Section of this Chapter will outline the remainder of this report.

1.5 Outline of Report.

In Chapter 2, several one-dimensional examples are examined as a clarification and motivation for the methodologies presented in Chapters 3 through 5. In addition, Chapter 2, Section 7, deals with the relationship between the Uncertainty Threshold Principle and the existence of a steady-state solution to the non-switching gain problem.

Chapter 3 develops the optimal solution to the class of problems described in Section 2 of this Chapter. The solution is labeled the switching gain solution because the gain of a linear feedback control law switches in response to the exact observation of the system structure with one-step delay.

Since Chapter 3 deals entirely with deterministic systems, and the switching gain solution does not extend optimally to the stochastic case, Chapter 4 presents some suboptimal methods which can be used to extend the switching gain solution to stochastic problems. Two methodologies are presented. One (hypothesis testing) is based entirely on estimation of the structure. The second (dual identification) uses the dual effect of the control law to determine more precisely what the structure is with the next observation. The optimal control law would have some characteristics of both methodologies, as is shown by example

in Chapter 2, Section 5.

Chapter 5 derives a control law which ignores any on-line information which might be gathered about the structural state, and results in a non-switching gain solution used in a linear feedback control law. The stability of this non-switching solution is explored, along with the existence of a steady-state solution, in Section 7. In Section 9, the robustness issue is addressed, and the non-switching methodology is used to define an algorithm which can determine the existence of a robust gain and calculate an optimal robust gain with respect to a quadratic cost functional, when one exists.

Chapter 6 focuses on the issues of computer-aided design and the application of the non-switching gain methodology to design problems. Two examples are used to demonstrate the effectiveness of the non-switching methodology in design.

Chapter 7 reviews the results described in the report and suggests new directions for future research.

CHAPTER 2

CLARIFICATION AND MOTIVATION OF RESEARCH

2.1 Introduction.

The purpose of this Chapter is to motivate all subsequent more general Chapters with simple one-dimensional examples. In particular, in Section 2, a one-dimensional problem is formulated and solved to illustrate the optimal (switching gain) deterministic control for linear quadratic systems with variable actuator configurations.

The effects of process noise on this solution are examined in Section 3. The dual effects which occur in the stochastic systems motivate the suboptimal approaches described in Chapter 4.

The possibility of steady-state control of variable actuator configuration systems with a single linear independent control law is discussed in Section 6, motivating the work on the non-switching gain solution and robust control laws in Chapter 5. In addition, the possibility of existence of a steady-state stabilizing linear feedback control law with constant gain is compared with the work on the Uncertainty Threshold Principle [Athans,et.al.,37] in Section 7. Section 7 contains the only case of this report where exact algebraic conditions for the existence of a steady-state solution have been derived. Unfortunately, these results do not readily extend in an analytical manner to higher dimensions.

The question of existence of a steady-state solution to these problems is of great importance. A system design is defined to be reliable with respect to a certain class of control laws if there

exists a control law from that class for which the infinite time cost incurred using that control law is finite. Since the switching and non-switching gain solutions are the optimal solutions for their respective classes of control laws, if they incur an infinite cost, so will any other control law from that class. In addition, since the switching gain solution is the optimal control law for the deterministic problem, a system design is termed deterministically reliable, or reliable if and only if the incurred infinite time expected cost is finite.

In the next Section, a one-dimensional example is presented which will be used to motivate the remainder of this report by examining the ramifications of the switching and non-switching gain solutions through their specific application to the example.

2.2 A Simple Example--The Optimal Solution.

The following one-dimensional example is used to demonstrate the switching gain methodology presented in Chapter 3, and to show that the general stochastic problem is analytically intractable. All proofs and derivations are given in Appendix 2.

2.2.1 Problem Statement.

Let the discrete-time system be one-dimensional with one control variable u_t and state variable x_t related by

$$x_{t+1} = ax_t + b_k u_t \quad (2.2.1)$$

The value of the control multiplier (b_k) is a random variable which takes on one of two discrete values at each time t .

$$b_k(t) = \begin{cases} b & \text{if } k = 0 \\ 1/b & \text{if } k = 1 \end{cases} \quad (2.2.2)$$

The random process $k(t)$ is governed by the Markov chain represented by

$$\underline{\pi}_{t+1} = \underline{P} \underline{\pi}_t \quad (2.2.3)$$

where

$$\underline{\pi}_t \in \mathbb{R}^2 \quad (2.2.4)$$

$$\underline{P} = \begin{bmatrix} p_{11} & p_{12} \\ p_{21} & p_{22} \end{bmatrix} \quad (2.2.5)$$

At any given time t , the following sequence of events occurs:

- I) x_t is observed exactly, $b_{k(t-1)}$ is computed, and $k(t-1)$ is set to 0 or 1 depending on $b_{k(t-1)}$, where $k(t-1)$ is the variable representing the Markov chain;
- II) $b_{k(t-1)}$ may change values to $b_{k(t)}$;
- III) u_t is applied.

For any given sample path, the performance index is given by

$$J = \sum_{t=0}^T (qx_t^2 + ru_t^2) \quad (2.2.6)$$

where $\{0, 1, \dots, T\}$ is the time set over which the system is to be controlled. The objective of the control problem is to minimize the expected cost-to-go at time t , given by

$$V(x_t, k(t-1), u_t, t) = E \left[\sum_{\tau=t}^T (qx_\tau^2 + ru_\tau^2) \mid k(t-1) \right] \quad (2.2.7)$$

where the expectation is taken over all possible sample paths of $k(\tau)$, $t < \tau \leq T$.

2.2.2 Summary of Solution.

From Appendix 2.1, we find that the optimal control is given by

$$u_t = - \frac{\pi_{0,t} abS_{0,t} + \pi_{1,t} (a/b)S_{1,t+1}}{r + \pi_{0,t} b^2 S_{0,t} + \pi_{1,t} (1/b^2)S_{1,t+1}} x_t \quad (2.2.8)$$

where

$$\underline{\pi}_t = \begin{bmatrix} \pi_{0,t} \\ \pi_{1,t} \end{bmatrix} = \underline{P} \underline{\pi}_{t-1} \quad (2.2.9)$$

Thus, the control law is linear in the state x_t , and switches between two precomputable gains, depending on the value of $k(t-1)$.

Given x_t , x_{t-1} and u_{t-1}

$$\underline{\pi}_{t-1} = \begin{cases} \begin{bmatrix} 1 \\ 0 \end{bmatrix} & \text{if } \frac{x_t - ax_{t-1}}{u_{t-1}} = b \\ \begin{bmatrix} 0 \\ 1 \end{bmatrix} & \text{if } \frac{x_t - ax_{t-1}}{u_{t-1}} = 1/b \end{cases} \quad (2.2.10)$$

and $k(t-1) = 0$ if $\underline{\pi}_{t-1} = [1 \ 0]'$ or 1 if $\underline{\pi}_{t-1} = [0 \ 1]'$.

The optimal cost-to-go is

$$V^*(x_t, k=i, t) = x_t^2 S_{i,t} \quad (2.2.11)$$

where $S_{0,t}$ and $S_{1,t}$ are propagated backward in time by the following equations:

Assuming $k=0$ at time t , then $\underline{\pi}_t = [p_{11} \ p_{21}]'$ and

$$\begin{aligned}
 s_{0,t} = & q + \frac{r[p_{11} ab s_{0,t+1} + p_{21} (a/b) s_{1,t+1}]^2}{[r + p_{11} b^2 s_{0,t+1} + p_{21} (1/b^2) s_{1,t+1}]^2} \\
 & + p_{11} \left(a - \frac{b[p_{11} ab s_{0,t+1} + p_{21} (a/b) s_{1,t+1}]}{r + p_{11} b^2 s_{0,t+1} + p_{21} (1/b^2) s_{1,t+1}} \right)^2 s_{0,t+1} \\
 & + p_{21} \left(a - \frac{p_{11} ab s_{0,t+1} + p_{21} (a/b) s_{1,t+1}}{b[r + p_{11} b^2 s_{0,t+1} + p_{21} s_{1,t+1}/b^2]} \right)^2 s_{1,t+1} \quad (2.2.12)
 \end{aligned}$$

Assuming $k=1$ at time t , then $\underline{\pi}_t = [p_{12} \ p_{22}]'$ and

$$\begin{aligned}
 s_{1,t} = & q + \frac{r[p_{12} ab s_{0,t+1} + p_{22} (a/b) s_{1,t+1}]^2}{[r + p_{12} b^2 s_{0,t+1} + p_{22} (1/b^2) s_{1,t+1}]^2} \\
 & + p_{12} \left(a - \frac{b[p_{12} ab s_{0,t+1} + p_{22} (a/b) s_{1,t+1}]}{r + p_{12} b^2 s_{0,t+1} + p_{22} (1/b^2) s_{1,t+1}} \right)^2 s_{0,t+1} \\
 & + p_{22} \left(a - \frac{p_{12} ab s_{0,t+1} + p_{22} (a/b) s_{1,t+1}}{b[r + p_{12} b^2 s_{0,t+1} + p_{22} s_{1,t+1}/b^2]} \right)^2 s_{1,t+1} \quad (2.2.13)
 \end{aligned}$$

Note from equation (2.2.8) that u_t switches from one linear gain to another, depending on the value of x_t -- thus, this solution depends on an exact knowledge of x_t . If knowledge of x_t is corrupted by measurement noise (or, if u_t is corrupted by control noise), then it will be shown by example that this becomes a dual control problem.

2.3 The Dual Control Effect.

To demonstrate the difficulties encountered when white process noise is present, the optimal solution for the one dimensional example is derived over the time interval $\{0,1,2\}$ with additive white control noise present. The system is now represented by

$$x_{t+1} = ax_t + b_{k(t)}u_t + \xi_t \quad (2.3.1)$$

ξ_t is discrete time white noise with zero mean, $E[\xi_t \xi_\tau] = E\delta_{t-\tau}$, probability distribution $\rho(\xi)$, and is uncorrelated with x_τ and $k(\tau)$ for $\tau \leq t$.

Thus, the problem is to find u_0^* and u_1^* such that the expected cost-to-go is minimized.

From Appendix 2.2, the optimal control one step back in time (at $t=1$) is

$$u_1^* = - \frac{\left[\sum_{i=0}^1 \pi_i(1|1)b_i \right] qa}{r + \left[\sum_{i=0}^1 \pi_i(1|1)b_i^2 \right] q} x_1 \quad (2.3.2)$$

where $\pi_i(1|1)$ is the probability that $k_1 = i$, given the information set $Z_1 = \{\pi_0, x_0, u_0, x_1\}$. As expected, this control is of the same form as is the deterministic control law, equation (2.2.8), since there is no benefit in trying to determine k_1 more accurately through the use of a special control value. In other words, there is no dual control effect at $t = T_f - 1$ (in this example, $t=1$).

At $t=0$, the situation is different. Now, the optimal control will force the system to supply more information through the state at $t=1$ than it normally would in the absence of the process white noise ξ_t .

In order to compute u_0^* , a numerical minimization of a numerical integration (in general) must be performed. Thus, u_0^* is the solution of

$$\begin{aligned}
 v^*(x_0, 0) = \min_{u_0 = \phi_0(Z_0)} & \left\{ x_0^2 q + u_0^2 r + \mathbb{E}q \right. \\
 + \sum_{k_0=0}^1 & \left[\sum_{k_1=0}^1 \int_{R(x_1)} x_1^2 \left[q(1+a^2) \right. \right. \\
 - \frac{\left[\sum_{i=0}^1 \pi_i(1|1)b_i \right]^2 q^2 a^2}{r + \left[\sum_{i=0}^1 \pi_i(1|1)b_i^2 \right] q} & \left. \left. \left[dp(x_1 | k_1, k_0, Z_0) p_{k_1 k_0} \right] \pi_{k_0, 0} \right\} \right.
 \end{aligned} \tag{2.3.3}$$

where

$$\pi_k(1|1) = \sum_{j=0}^1 p_{kj} \frac{\rho(x_1 - ax_0 - b_j u_0) \pi_{j,0}}{\sum_{i=0}^1 \rho(x_1 - ax_0 - b_i u_0) \pi_{i,0}} \tag{2.3.4}$$

and $p(x_1 | k_1, k_0, Z_0)$ is the probability measure of x_1 over $R(x_1)$, the range of x_1 , given k_1 , k_0 , and Z_0 .

Equation (2.3.3) is very difficult to solve numerically, and for any realistically-sized problem would be economically infeasible. For the limited amount of computation that has been done with equation (2.3.3), the dual control effect is evident from Table 2.1. Note that as the process noise variance increases, the trend is for the control u_0^* to increase. This is due to the need for a larger control to lessen the effect of noise on future estimations of the structure.

Table 2.1

The optimal control u_0^* versus x_0 and $\bar{\epsilon}$.

| x_0 | u_0^* ($\bar{\epsilon}=3$) | u_0^* ($\bar{\epsilon}=6$) | u_0^* ($\bar{\epsilon}=10$) |
|-------|--------------------------------|--------------------------------|---------------------------------|
| -2.0 | 2.3170089 | 2.3188635 | 2.3201611 |
| -1.6 | * | 1.8550055 | 1.8559061 |
| -1.2 | 1.3898305 | 1.3907551 | 1.3912676 |
| -0.8 | 0.9255912 | 0.9259997 | 0.9261950 |
| -0.4 | 0.4606236 | 0.4606920 | 0.4607206 |
| 0.0 | -0.005 | -0.005 | -0.005 |
| 0.4 | -0.4706236 | -0.4706920 | -0.4707206 |
| 0.8 | -0.9355912 | -0.9359997 | -0.9361950 |
| 1.2 | -1.3998305 | -1.4007551 | -1.4012676 |
| 1.6 | -1.8635511 | -1.8650055 | -1.8659061 |

* - calculation did not converge due to numerical errors

The system used in the calculations is described by equation

(2.2.1) where

$$a = 2.$$

$$k(t) \text{ is } 0 \text{ or } 1$$

$$b_0 = 2.$$

$$b_1 = .5$$

$$q = 3.$$

$$r = 1.$$

$$\underline{P} = \begin{bmatrix} .7 & .3 \\ .3 & .7 \end{bmatrix}$$

$$\underline{\Pi}_0 = \begin{bmatrix} .5 \\ .5 \end{bmatrix}$$

Table 2.1 is only intended to demonstrate the difference in the optimal control laws at time 0 for a two-stage process; numerical accuracy is not assured. Specifically, the values of $-.005$ for u_0^* ($x_0 = 0$) are highly doubtful, as well as the consistent asymmetry between positive and negative values in the Table.

2.3.1 A Special Case.

It is interesting that for one specialized probability distribution $\rho(\xi)$, when the optimal control u_0^* is large enough, the optimal solution is identical with the deterministic solution of Section 2.

From Appendix 2.3, assuming

$$\rho(\xi) = \begin{cases} \frac{1}{2\sqrt{3E}}, & \text{for } -\sqrt{3E} \leq \xi \leq \sqrt{3E} \\ 0 & \text{otherwise} \end{cases} \quad (2.3.5)$$

as shown in Figure 2.1, if u_0^* from the deterministic solution (equation 2.2.8) satisfies

$$|(b_{k_0} - b_i)u_0^*| > 2\sqrt{3E} \quad \text{for } k_0 \neq i \quad (2.3.6)$$

then u_0^* is also the solution to the stochastic control problem.

Physically, because the noise is amplitude limited, it is easy to exactly deduce the structure if the control is large enough.

76265AW023

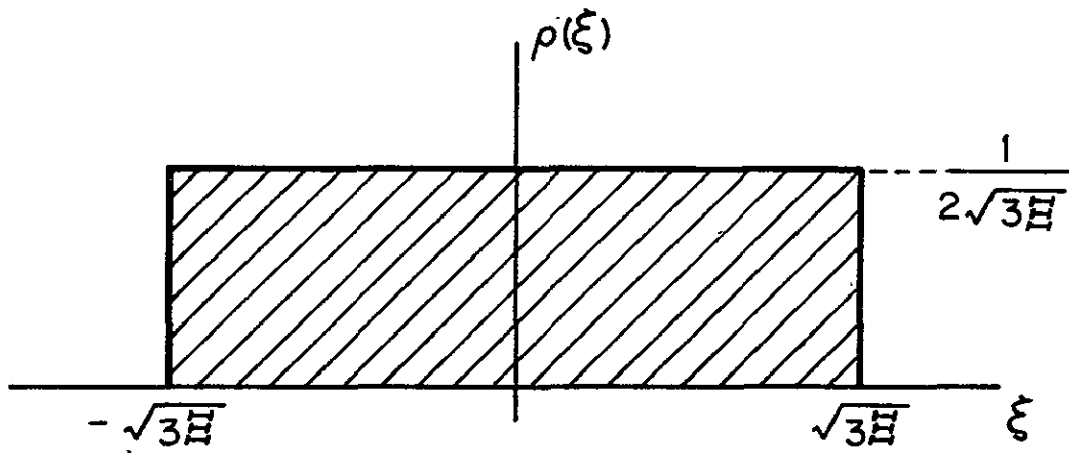

Figure 2.1: A probability distribution for amplitude-limited white noise.

2.4 Existence of a Steady-State Solution.

Although, as will be stated in Chapter 3, little can be said about the existence of a steady-state solution to the general n-dimensional switching gain problem, for the one-dimensional example, exact conditions for the existence of a steady-state solution can be found. They are in the form of two simultaneous algebraic equations which can be solved analytically.

$$\begin{aligned} \Gamma &= p_{11} \left(a - \frac{b[p_{11}ab + p_{21}(a/b)h]}{p_{11}b^2 + p_{21}(1/b^2)h} \right)^2 \\ &+ p_{21} \left(a - \frac{p_{11}ab + p_{21}(a/b)h}{b[p_{11}b^2 + p_{21}h/b^2]} \right)^2 h \end{aligned} \quad (2.4.1)$$

$$\begin{aligned} h\Gamma &= p_{12} \left(a - \frac{b[p_{12}ab + p_{22}(a/b)h]}{p_{12}b^2 + p_{22}(1/b^2)h} \right)^2 \\ &+ p_{22} \left(a - \frac{p_{12}ab + p_{22}(a/b)h}{b[p_{12}b^2 + p_{22}h/b^2]} \right)^2 h \end{aligned} \quad (2.4.2)$$

The equations are derived in Appendix 2.4. In these equations the variables Γ and h are defined as

$$\Gamma = \lim_{t \rightarrow -\infty} \frac{S_{0,t}}{S_{0,t+1}} \quad (2.4.3)$$

and

$$h = \lim_{t \rightarrow -\infty} \frac{S_{1,t}}{S_{0,t}} \quad (2.4.4)$$

whenever both $S_{0,t}$ and $S_{1,t}$ increase without bound as $t \rightarrow -\infty$, as defined in equations (2.2.12) and 2.2.13).

Since Γ is the limiting value of the ratio of the next value of $S_{0,t}$ to the present value $S_{0,t+1}$, it is necessary that

$$\Gamma \geq 1 \quad (2.4.5)$$

for

$$S_{0,t} \rightarrow \infty \quad (2.4.6)$$

Similarly, if $S_{0,t}$ has a limit, then Γ can have a maximum value of

1. Therefore, a test can be made on the solution (h, Γ) to equations (2.4.1) and (2.4.2) for the existence of a steady-state solution:

If

$$h \neq 0 \text{ or } \infty \quad (2.4.7)$$

then

$$S_{0,t}, S_{1,t} \rightarrow \infty \text{ if } \Gamma > 1 \quad (2.4.8)$$

$$S_{0,t}, S_{1,t} \text{ converge if } \Gamma < 1 \quad (2.4.9)$$

and there is no conclusion if $\Gamma = 1$.

By way of eliminating all possibilities, as an aside, a limit cycle to the solution of equations (2.2.12) and (2.2.13) cannot occur by Lemma 1 of Chapter 3.

2.5 Conclusions on the Switching Gain Methodology.

The purpose of the last three Sections on the one-dimensional switching gain example was to clarify the approach of this phase of the research, and to motivate the approach of Chapters 3 and 4. In this Section, some implications of the one-dimensional example will be discussed.

2.5.1 Implications of the Dual Control Effect.

It was shown in Section 2 that the optimal solution to the deterministic class of variable actuator linear quadratic control problems; i.e., the switching gain solution, is conceptually straightforward, although computationally complex off-line. Unfortunately, in Section 3, it was demonstrated that the optimal solution of the stochastic version of the same problem is infeasible. (Witness the problems of calculating the two-step optimal solution.) Therefore, since the switching gain deterministic solution is essentially the only solution which can be described analytically, the research involved in developing the n-dimensional switching gain solution is justified. This is exactly what is presented in Chapter 3.

It then remains to investigate any extensions (which will of necessity be suboptimal) which may be made to the switching gain solution to adapt the solution to the stochastic problem. In Chapter 4, a start is made in that direction. These are two basic routes to follow: The various hypothesis testing algorithms in combination with the switching gain solution, and a formulation developed in Chapter 4 which gives the control vector a dual effect; the control is changed to increase the accuracy of the estimation algorithm. The optimal control would use techniques from both categories, as the dual effect is clearly seen in Table 2.1.

2.5.2 Existence of a Steady-State.

Although for the one-dimensional example, it is possible to determine the condition for convergence of the Riccati-like equations

(2.2.12) and (2.2.13), this method does not extend to the n-dimensional solution. It is at present unknown under what conditions the Riccati-like equations for the n-dimensional problem converge; therefore, there is little comment on conditions for convergence in the remainder of this report.

2.6 A Simple Example--The Non-Switching Solution.

In the previous sections of this Chapter, motivation was given for the development of the optimal (switching) solution to the linear quadratic variable actuator configuration control problem. Several problems with the method were pointed out in Section 5. Specifically, the methodology does not extend optimally to the stochastic case due to the dual control effect. Secondly, the increase in on-line complexity over the usual linear quadratic control problem is significant, especially in the suboptimal stochastic schemes.

In many instances, a stabilizing solution to this class of control problems is desired which exhibits the same complexity as does the usual linear quadratic controller. For instance, it may be desired that a control law stabilize a system without requiring error detection strategies and switching to a new form upon detection of failure. A subclass of these problems occur when a robust gain (one which stabilizes each configuration without regard for the dynamics of structural changes) for a set of linear systems is desired. The first problem within this subclass deals with the existence of such a gain. The second problem deals with the choice of an optimum robust gain with respect to some cost index.

In the following Subsections, an example of non-switching gain methodology is given as an illustration of the concepts; since the derivations are quite complex, proofs are deferred until Chapter 5, where the entire development of the non-switching solution is presented.

The following formulation is only for the steady-state solution; in Section 7, the conditions for existence of the steady-state solution will be given and related to the Uncertainty Threshold Principle [Athans, et. al.,]

2.6.1 Problem Statement

In Chapter 5, the non-switching control problem is solved for linear systems with variable actuator configurations and quadratic cost. It was stated in the conclusion of the previous Section that a relationship exists between the existence of a steady-state solution and the Uncertainty Threshold Principle. In this Subsection, the existence of a steady-state non-switching solution to the one dimensional example presented in Section 2 will be studied to illustrate this relationship.

The system to be used is

$$x_{t+1} = ax_t + b_k u_t \quad (2.6.1)$$

where x , a , b_i and u are scalars, k can be either 0 or 1, and t takes on integer values.

$$b_i = \begin{cases} b & \text{if } k=0 \\ 1/b & \text{if } k=1 \end{cases} \quad (2.6.2)$$

The index k represents the structural state of the system, and is a random variable with statistics generated by the Markov chain

$$\underline{\pi}_{t+1} = \underline{P} \underline{\pi}_t \quad (2.6.3)$$

$$\underline{P} = \begin{bmatrix} p & 1-p \\ 1-p & p \end{bmatrix} \quad (2.6.4)$$

where $\underline{\pi}_{i,t}$ is the probability that the structural state is i at time t , given some initial condition $\underline{\pi}(\underline{T}_{init})$.

The infinite-time, or steady-state non-switching control problem is formulated by specifying that the solution u_t is to minimize the cost of a trajectory $(k_t, u_t)_{t=\underline{T}_{init}}^{\infty}$ given by the sum

$$J = \sum_{t=\underline{T}_{init}}^{\infty} q x_t^2 + r u_t^2 \quad (2.6.5)$$

2.6.2 Summary of Solution

The solution is computed, from Chapter 5, equations (5.7.17) and (5.7.18), when it exists, as the solution (S_0, S_1) of

$$S_0 = a^2 \left(p \left(S_0 - \frac{(bS_0 + S_1/b) b S_0}{\frac{1}{2}(b^2 S_0 + S_1/b^2) + r} + \frac{(bS_0 + S_1/b)^2 (r + b^2 S_0)}{4(\frac{1}{2}(b^2 S_0 + S_1/b^2) + r)^2} \right) + (1-p) \left(S_1 - \frac{(bS_0 + S_1/b) S_1}{(\frac{1}{2}(b^2 S_0 + S_1/b^2) + r)b} + \frac{(bS_0 + S_1/b)^2 (r + S_1/b^2)}{4(\frac{1}{2}(b^2 S_0 + S_1/b^2) + r)^2} \right) \right) + q \quad (2.6.6)$$

$$S_1 = a^2 \left((1-p) \left(S_0 - \frac{(bS_0 + S_1/b) b S_0}{\frac{1}{2}(b^2 S_0 + S_1/b^2) + r} + \frac{(bS_0 + S_1/b)^2 (r + b^2 S_0)}{4(\frac{1}{2}(b^2 S_0 + S_1/b^2) + r)^2} \right) + p \left(S_1 - \frac{(bS_0 + S_1/b) S_1}{(\frac{1}{2}(b^2 S_0 + S_1/b^2) + r)b} + \frac{(bS_0 + S_1/b)^2 (r + S_1/b^2)}{4(\frac{1}{2}(b^2 S_0 + S_1/b^2) + r)^2} \right) \right) + q \quad (2.6.7)$$

and the control is given by

$$u_t^* = - \frac{(bs_0 + s_1/b)a}{(r + \frac{1}{2}(b^2 s_0 + s_1/b^2))} \cdot x_t \quad (2.6.8)$$

Note that the steady-state solution is a linear feedback control law with a constant gain which is pre-computable using equations (2.6.6) and (2.6.7). The on-line implementation of this solution has the same complexity as does the usual linear quadratic steady-state solution.

2.7 Existence of a Steady-State Solution and the Uncertainty Threshold Principle.

In this Section, the existence of a steady-state solution to equations (2.6.6) and (2.6.7) is related to the Uncertainty Threshold Principle [Athans et. al.,37]. This Principle states that for a certain class of systems, there exists a threshold, or bound, on the degree of uncertainty in the system dynamics beyond which no control law will stabilize the system. Furthermore, it is noted in [Athans et. al.,37] that there does exist a "minimizing" control even though the infinite-time cost is infinite.

For the non-switching gain class of controllers, it will be shown in this Section that, at least for the one-dimensional example of Sections 2 and 6; such a threshold does exist; furthermore, it will be explicitly calculated. In addition, it will be demonstrated that the non-switching control gain converges even when no finite cost steady-state solution exists.

2.7.1 Formulation of Existence Problem.

The question is now asked: When does the steady state solution exist? I.e., when is the cost, given by

$$J = \frac{1}{2}(S_0 + S_1)x_0^2 \quad (2.7.1)$$

finite?

This problem is solved by showing when the solution does not exist.

Allowing

$$S_0 \rightarrow \infty \quad (2.7.2)$$

and setting

$$h = \lim_{t \rightarrow -\infty} \frac{S_{1,t}}{S_{0,t}} \quad (2.7.3)$$

$$\Gamma = \lim_{t \rightarrow -\infty} \frac{S_{0,t}}{S_{0,t+1}} \quad (2.7.4)$$

where $S_{0,t}$ and $S_{1,t}$ are the values of the r.h.s. of equations (2.6.6) and (2.6.7) iterated backwards t times from an initial value $S_{i,0} = Q$, equations (2.6.6) and (2.6.7) become

$$\Gamma = a^2 \left(p \left(1 - \frac{(b+h/b)b}{\frac{1}{2}(b^2+h/b^2)} + \frac{(b+h/b)^2 b^2}{(b^2+h/b^2)^2} \right) + (1-p) \left(h \left(1 - \frac{(b+h/b)}{\frac{1}{2}(b^2+h/b^2)b} + \frac{(b+h/b)^2/b^2}{(b^2+h/b^2)^2} \right) \right) \right) \quad (2.7.5)$$

$$h\Gamma = a^2 \left((1-p) \left(1 - \frac{(b+h/b)b}{\frac{1}{2}(b^2+h/b^2)} + \frac{(b+h/b)^2 b^2}{(b^2+h/b^2)^2} \right) + p \left(h \left(1 - \frac{(b+h/b)}{\frac{1}{2}(b^2+h/b^2)b} + \frac{(b+h/b)^2/b^2}{(b^2+h/b^2)^2} \right) \right) \right) \quad (2.7.6)$$

2.7.2 Summary of Solution.

Equations (2.7.5) and (2.7.6) have 5 solutions. The solutions of h and Γ of interest are:

For $p \neq \frac{1}{2}$:

$$h = -(p(b^4(6-2W)-3b^8-3)+((2b^4-2)p-b^4+1)V + (4b^8-2b^4+2)p^2+b^8-2b^4+1)/((2b^4+2)p^2-2pw) \quad (2.7.7)$$

$$\Gamma = a^2 (-p[b^4(2p^2+4p-2)+(b^8+1)(p^2-2p+1)]^{\frac{1}{2}}+(b^4+1)p^2) / ((b^2+1)^2(2p-1)) \quad (2.7.8)$$

where

$$V = [b^4(p(4-4[b^4(2p^2+4p-2)+b^8(p^2-2p+1)+p^2-2p+1])^{\frac{1}{2}} + 2p^2-2) + b^8(5p^2-2p+1)+p^2-2p+1]^{\frac{1}{2}} \quad (2.7.9)$$

and

$$W = [(b^8+2b^4+1)p^2+(-2b^8+4b^4-2)p+b^8-2b^4+1]^{\frac{1}{2}} \quad (2.7.10)$$

For $p = \frac{1}{2}$;

$$h = 1 \quad (2.7.11)$$

$$\Gamma = \frac{a^2(b^2-1)^2}{2(b^4+1)} \quad (2.7.12)$$

2.7.3 Graphical Illustration of Solution.

Equations (2.7.7) through (2.7.12) are too complex for much information to be gleaned from study. Therefore, their significance is demonstrated graphically in this section.

These equations are used to compute the absolute values of a versus b and p above which no stabilizing non-switching control exists; i.e., since Γ is the limiting ratio of $S_{0,t}$ to $S_{0,t+1}$, what threshold value of $|a|$ yields $\Gamma = 1$? Since the system (2.6.1) is a discrete time one, this threshold quantifies how unstable the open-loop system must be for there to be no stabilizing solution. This quantity is called the uncertainty threshold value of $|a|$. For the case $p = \frac{1}{2}$, $|a|_{\text{threshold}}$ is easy to compute from equation (2.7.12)

$$|a|_{\text{threshold}} = \frac{[2(b^4+1)]^{\frac{1}{2}}}{|b^2-1|} \quad (2.7.13)$$

For $p \neq \frac{1}{2}$,

$$|a|_{\text{threshold}} = \frac{(b^2+1)[(2p-1)]}{\left[(p((b^4+1)p - [b^4(2p^2+4p-2) + (b^8+1)(p^2-2p+1)]^{\frac{1}{2}}) \right]^{\frac{1}{2}}} \quad (2.7.14)$$

A plot of $|a|_{\text{threshold}}$ versus p (long axis) and b is shown in Figure 2.2.

76265AW024

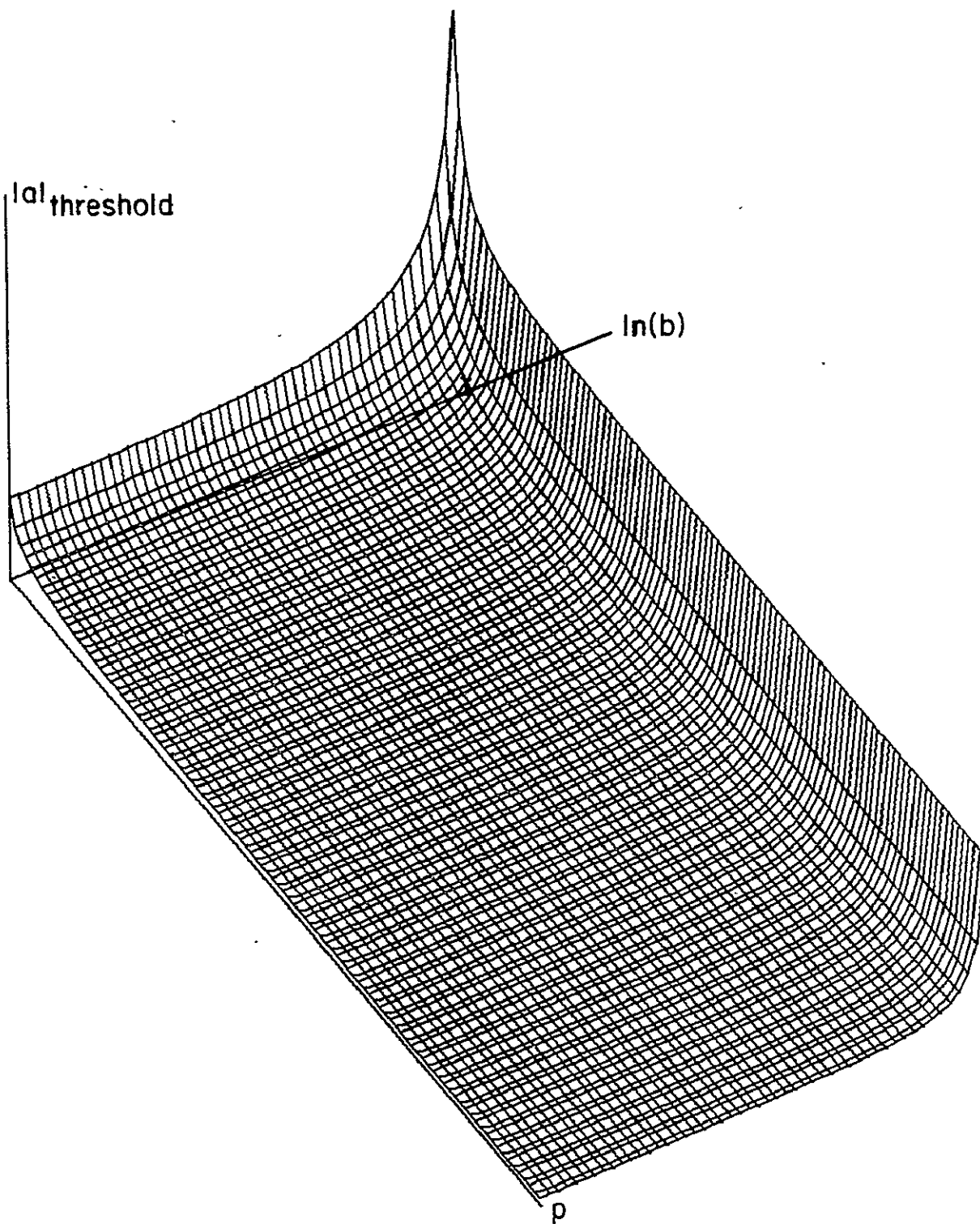

Figure 2.2: $|a|_{\text{threshold}}$ versus p , b .

The $\ln(b)$ axis is used because $|a|_{\text{threshold}}$ is symmetric with respect to $\ln(b)$ around zero ($|a|_{\text{threshold}}(b) = |a|_{\text{threshold}}(1/b)$). b varies from $e^{-2.5}$ to $e^{-.05}$; p varies from $p = 1$ to $p = .01$. Note that $|a|_{\text{threshold}} \rightarrow \infty$ as $b \rightarrow 1$ and/or $p \rightarrow 0$. This is because as $b \rightarrow 1$, the system looks more and more like

$$x_{t+1} = ax_t + bu_t \quad (2.7.15)$$

which is controllable for all values of a . As $p \rightarrow 0$, the system is switching more and more rapidly between the two structures; therefore, each structure has less time to influence the system unfavorably and the system becomes easier to control, leading to $|a|_{\text{threshold}} \rightarrow \infty$.

2.7.4 Best Control with Infinite Cost.

Although the cost may be infinite, a finite gain control exists. From equation (2.6.8), and allowing $S_0 \rightarrow \infty$ and $S_1/S_0 \rightarrow h$, the control becomes

$$u_t^* = - \frac{(b+h/b)a}{(b^2+h/b^2)} x_t \quad (2.7.16)$$

Note that the control gain does not depend on q or r , but only on p , a and b , as in the work with the Uncertainty Threshold Principle. A plot of h versus p (long axis) and b is given in Figures 2.3a and 2.3b, in the same manner as for Γ . Note that as $p \rightarrow 0^+$, $h \rightarrow \infty$ (except at $b = 1$). For this boundary, we rely on a symmetric argument, switching the roles of S_0 and S_1 , since we only know that $S_1 \rightarrow \infty$.

An interesting symmetry exists in h with respect to p . If \bar{h} is defined as

$$\bar{h} = \lim_{b \rightarrow 0} h \quad (2.7.17)$$

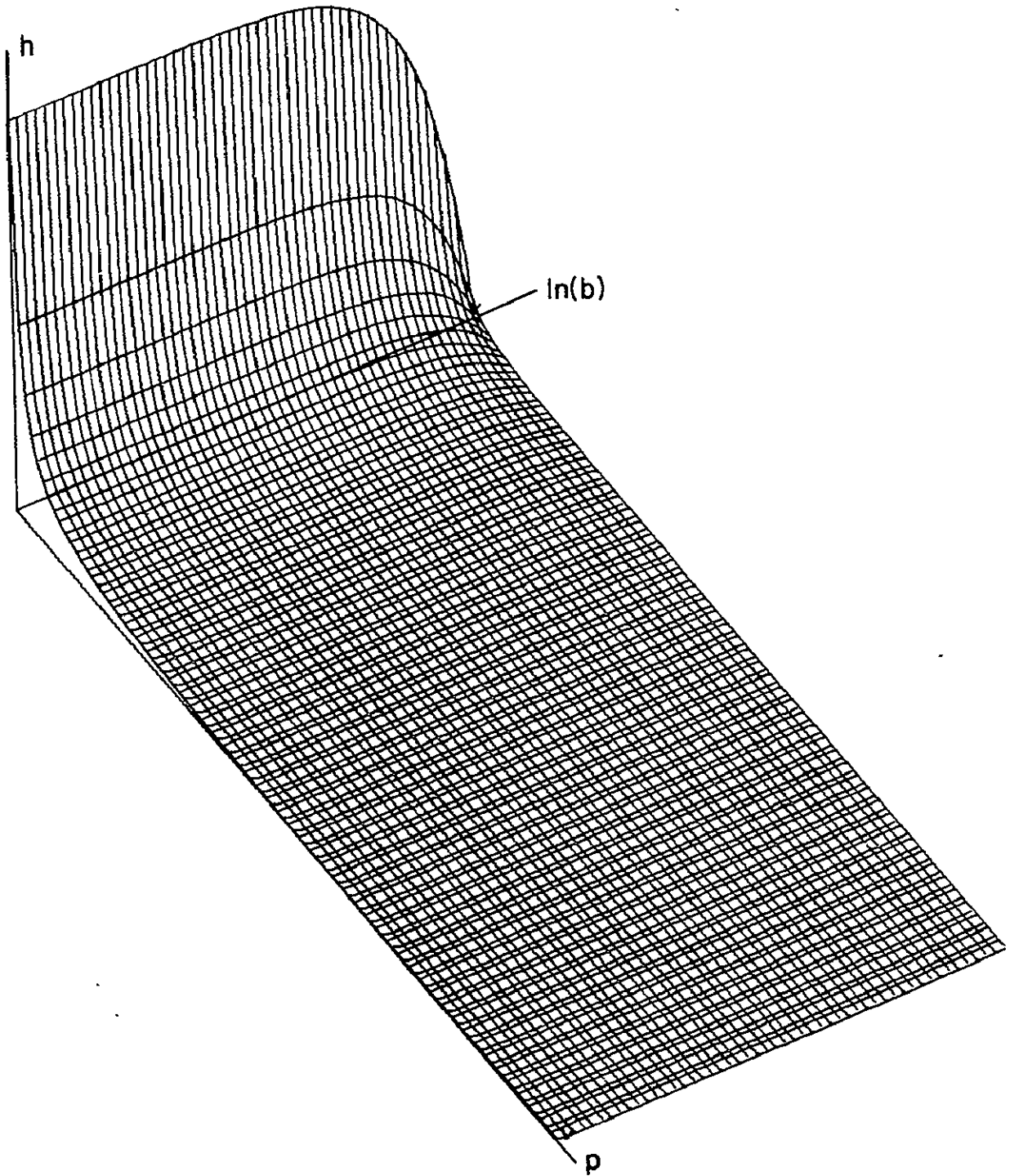

Figure 2.3a: h versus p, b .

ORIGINAL PAGE IS
OF POOR QUALITY

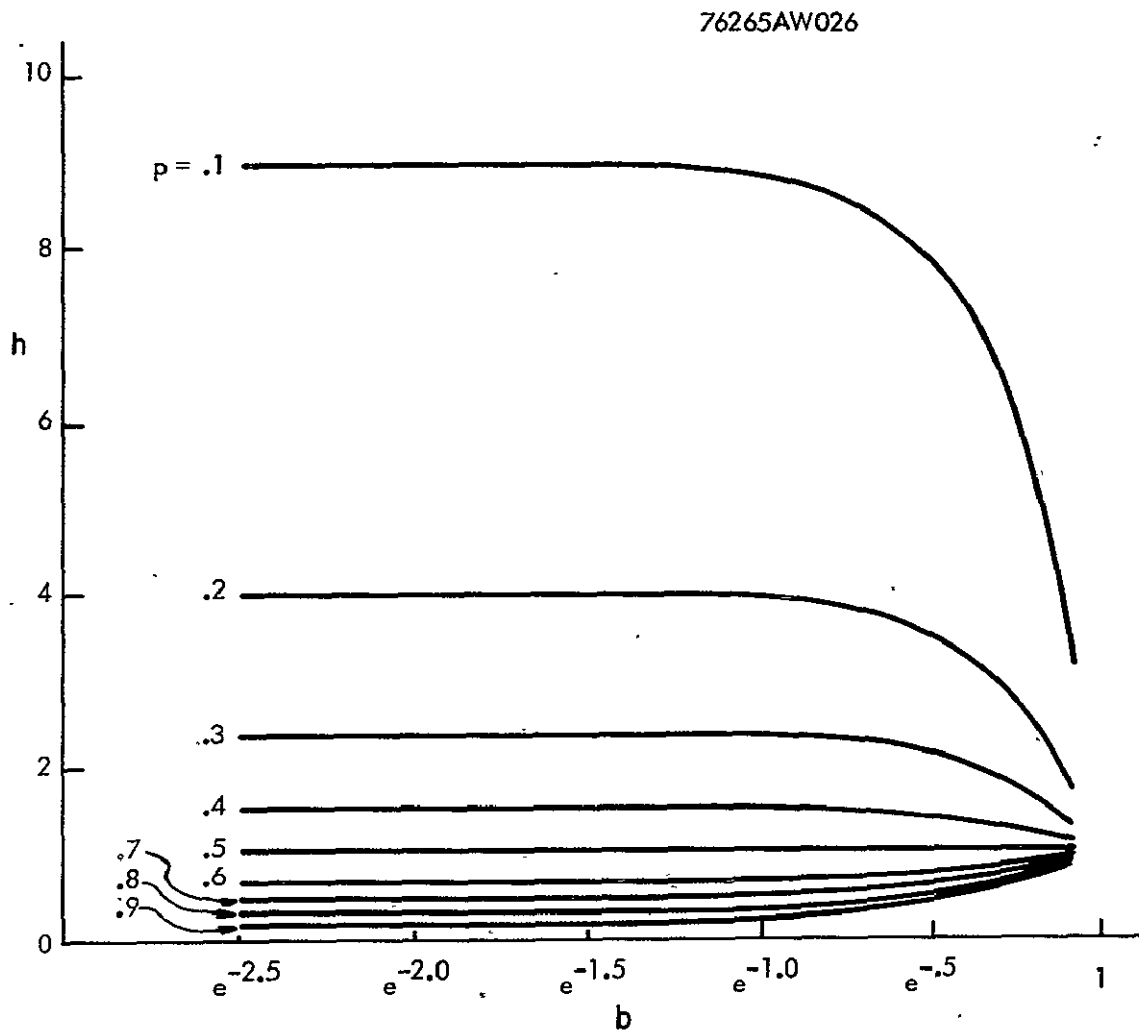

Figure 2.3b: h versus p , b .

then

$$\bar{h} = \frac{1-p}{p} \quad (2.7.18)$$

Letting $p = \frac{1}{2} + x$,

$$\bar{h}(x) = \frac{1-2x}{1+2x} \quad (2.7.19)$$

and

$$\bar{h}(x) = \frac{1}{\bar{h}(-x)} \quad (2.7.20)$$

Thus, $\ln[\bar{h}(p)]$ is symmetric around $p = .5$. This solves the boundary problem, because as $p \rightarrow 1$, $h \rightarrow 0$ (except at $b = 1$), and the condition $S_0 \rightarrow \infty$ is satisfied ($S_1 \rightarrow 0$). Since \bar{h} is symmetric, and $h(p,b) \rightarrow \bar{h}(p)$ for $p \rightarrow 0$, the solution is well-defined at $p = 0$.

In Figure 2.4, the control gain divided by a , g , is plotted as a function of p and b .

$$u_t^* = -gax_t \quad (2.7.21)$$

Note that as $p \rightarrow 0^+$ (and $h \rightarrow \infty$), $g \rightarrow b$, and as $p \rightarrow 1^-$ (and $h \rightarrow 0$), $g \rightarrow 1/b$, and that $b_0 = b$ and $b_1 = 1/b$. Thus, as $p \rightarrow 0^+$, the optimal gain tends towards the deadbeat controller for the system in structural state 1, and as $p \rightarrow 1^-$, the optimal gain tends towards the deadbeat controller for the system in structural state 0.

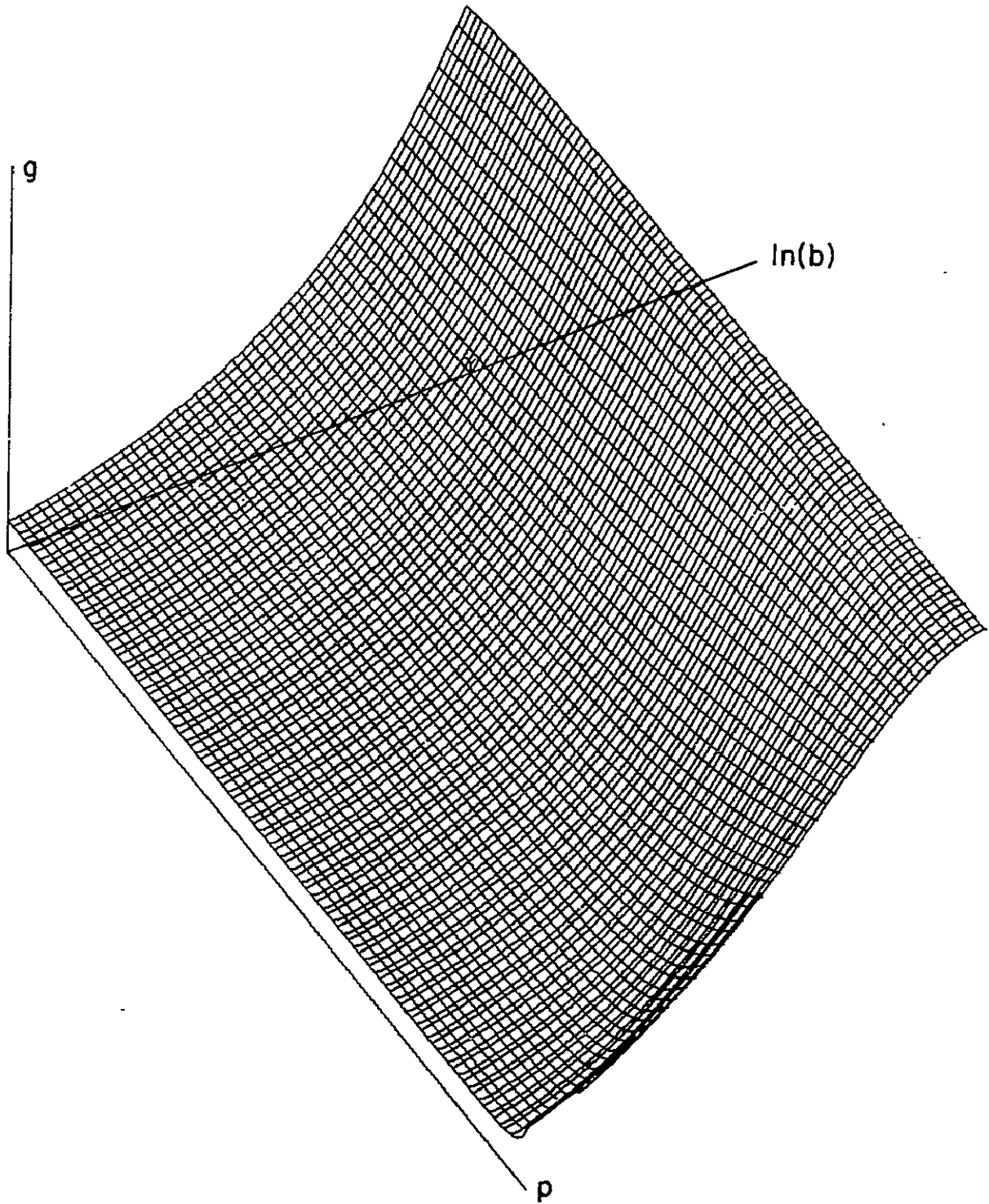

Figure 2.4: g versus p, b .

ORIGINAL PAGE IS
OF POOR QUALITY

2.7.5 Conclusion.

In this Section, the steady-state properties of the non-switching solution to a specific example of actuator failure were studied, and were related to the Uncertainty Threshold Principle. In particular, the existence of an uncertainty threshold has been established, and with the help of the high degree of symmetry in the example, the values for $|a|_{\text{threshold}}$, given b and p , were calculated. It was also shown that the best control with infinite cost is a function only of a , b and p , a situation analogous to the solution obtained in the papers on the Uncertainty Threshold Principle [Athans et. al.,37].

An analogous solution to that presented here should exist for the switching gain problem, and in fact, the rudiments of such a solution are given in Section 4. As a guide for future research, it would be interesting to compare the two methodologies on the basis of these solutions. Unfortunately, it is mathematically intractable to extend this result to the multivariable case, although another approach may be found.

2.8 Summary.

The unifying issue in this research is the interrelationship between the issues of control and reliability. Section 7 brushes on the question of when a system design is considered a reliable design. In Chapter 3, a reliable design will be defined as one in which the steady-state switching gain solution exists. Therefore, questions concerning the existence of such solutions become quite important. Unfortunately, little headway has been made in the development of any simple test for the existence of the steady-state solution. Only in

Section 7, in the specific case of the non-switching gain solution, for a specific (relatively trivial) example, and in Section 4 for the same example with the optimal solution, have conditions for existence of a steady-state been resolved. In Section 7, these conditions are given explicitly; in Section 4, they are given as the solution to two simultaneous equations. For the general n-dimensional problems in the remainder of this report, existence can only be tested by iteration of the solution equations.

CHAPTER 3

THE SWITCHING GAIN SOLUTION

3.1 Introduction.

In this Chapter, a control methodology for linear systems with quadratic cost criteria and variable actuator configurations will be developed which accounts for the failure, repair and reconfiguration of the actuators by switching the control gain on detection of a change in configuration. This problem is viewed as a control problem rather than as the traditional estimation problem. Therefore, a deterministic model is assumed, except for the random changes in configuration, which are modeled by a Markov chain. This methodology has the advantage that all gain and expected cost calculations are done off-line. The gains switch on-line with changes in the configuration, which are observable with one-step delay for almost all values of \underline{u}_t (i.e., except for a set of measure zero). In addition, the method is useful in the stochastic case, though not optimal, in conjunction with identification methods such as hypothesis testing and dual identification, which will be described in Chapter 4. The gain and expected cost calculations can be used as an evaluation technique in computer-aided design of linear systems. An example would be in trade-off studies of various redundancy configurations with respect to performance, reliability, and system effectiveness. The disadvantages of the technique as it is presented here are that it requires perfect measurement of the state and that only multiple

actuator configurations are considered. The multiple sensor configuration problem should be dual to this work. Changes in the A matrix are a minor extension; however, the general problem allowing variations in both the actuators and the observers would be a major result.

Previously, several authors have studied the optimal control of systems with randomly varying structure. Most notable among these is [Wonham,22], where he develops a solution to the linear regulator problem with randomly jumping parameters in continuous time. The solution assumes apriori that the controller has perfect information about the present state of the random parameter process. Little work was done on the steady-state existence problem.

The solution presented in this Chapter is analogous to that of Wonham's; however, the discrete time formulation of the problem allows the controller to observe exactly with one step delay the value of the Markov parameter process. Thus, it is shown that for the discrete-time process, the optimal controller is not dual.

In addition to this conclusion, this research makes the connection, for the first time, of control and system reliability and effectiveness. This is the unifying concept in the entire report, and has been discussed in detail in Chapter 1.

The procedure for determining the existence of a steady-state solution to the switching gain control problem divides system designs into two classes: If a design allows a steady-state solution, then that solution is stabilizing (see Section 7, Chapter 5); therefore, that design is classified as a reliable design. On the other hand, if

no steady-state solution exists, then that design is classified as inherently unreliable.

Although no easy test exists for the existence of a steady-state solution, the computer can always be used to iterate equation (3.3.6) backward in time and check for stability. Therefore, this methodology yields a classification of systems into those which are inherently reliable and those which are not.

3.2 Mathematical Formulation.

In this Section, the n-dimensional extension to the one-dimensional switching gain result presented in Chapter 2 will be developed. The only non-trivial task is to prove that the system structure is observable for almost all values of the control. The system model is

$$\underline{x}_{t+1} = \underline{A}\underline{x}_t + \underline{B}_k(t)\underline{u}_t \quad (3.2.1)$$

where

$$\underline{x}_t \in \mathbb{R}^n \quad (3.2.2)$$

$$\underline{u}_t \in \mathbb{R}^m \quad (3.2.3)$$

$$\underline{A} \in \mathbb{R}^{n \times n} \quad (3.2.4)$$

and, for each k, an element of an indexing set I

$$k \in I = \{0, 1, 2, \dots, L\} \quad (3.2.5)$$

$$\underline{B}_k \in \mathbb{R}^{n \times m} \quad (3.2.6)$$

where

$$\underline{B}_k \in \{\underline{B}_i\}_{i \in I} \quad (3.2.7)$$

The index k(t) is a random variable taking values in I which is governed by a Markov chain and

$$\underline{\pi}_{t+1} = \underline{P}\underline{\pi}_t \quad (3.2.8)$$

$$\underline{\pi}_t \in R^{L+1} \quad (3.2.9)$$

where $\pi_{i,t}$ is the probability of $k(t) = i$, given no on-line information about $k(t)$, and $\underline{\pi}_0$ is the initial distribution over I .

It is assumed that the following sequence of events occurs at each time t :

- 1) \underline{x}_t is observed exactly
- 2) then $\underline{B}_{k(t-1)}$ switches to $\underline{B}_{k(t)}$
- 3) then \underline{u}_t is applied.

The control interval is assumed to be

$$\{0, 1, 2, \dots, T\} \quad (3.2.10)$$

and the cost function is selected as

$$\begin{aligned} J_T(\underline{x}_t, \underline{u}_t)_{t=0}^{T-1}, \underline{x}_T \\ = \sum_{t=0}^{T-1} \underline{x}_t^T \underline{Q} \underline{x}_t + \underline{u}_t^T \underline{R} \underline{u}_t + \underline{x}_T^T \underline{Q} \underline{x}_T \end{aligned} \quad (3.2.11)$$

The objective is to choose a feedback control law, which may depend on any past information about \underline{x}_t or \underline{u}_t , mapping \underline{x}_t into \underline{u}_t

$$\underline{\phi}_t^* : R^n \rightarrow R^m \quad (3.2.12)$$

$$\underline{\phi}_t^* : \underline{x}_t \rightarrow \underline{u}_t \quad (3.2.13)$$

such that the expected value of the cost function J_T from equation (3.2.11)

$$J_T = E[J_T | \underline{\pi}_0] \quad (3.2.14)$$

is minimized over all possible mappings $\underline{\phi}_t$ at $\underline{\phi}_t^*$.

3.3 The Switching Gain Solution.

Normally, a control law of the form (3.2.13) must provide both a control and an estimation function in this type of problem; hence the label dual control is used. Here, the structure of the problem allows the exact determination of $k(t-1)$ from \underline{x}_t , \underline{x}_{t-1} and \underline{u}_{t-1} for almost all values of \underline{u}_{t-1} . This result is stated and proved in the following theorem.

Theorem 1: For the set $\{\underline{B}_k\}_{k \in I}$, where the \underline{B}_k 's are distinct, the set $\{\underline{x}_{k,t+1} = \underline{A}\underline{x}_t + \underline{B}_k \underline{u}_t\}_{k=0}^L$ has distinct members for almost all values of \underline{u}_t .

Proof: See Appendix 3.1.

Ignoring the set of controls of measure zero for which the members of

$$\{\underline{x}_{k,t+1}\}_{k=0}^L \tag{3.3.1}$$

are not distinct, then for (almost) any control which the optimal algorithm selects, the resulting state \underline{x}_{t+1} can be compared with the members of the set (3.3.1) for an exact match (of which there is only one with probability 1), and $k(t)$ is identified as the generator of that matching member $\underline{x}_{k,t+1}$.

Since perfect identification is the best any algorithm can achieve, the optimal control law $\underline{u}_t^* = \underline{\phi}_t^*(\underline{x}_t)$ can be calculated with the assumption that $k(t-1)$ is known, since this is the case with probability one. Thus, this solution will be labeled the switching gain solution, since, for each time t , $L+1$ optimal solutions are calculated apriori, and one solution is chosen on-line for each time t , based on the past

measurements \underline{x}_t , \underline{x}_{t-1} and \underline{u}_t , which yield perfect knowledge of $k(t-1)$.

Dynamic programming will be used to derive the optimal switching gain solution. At each time t , the expected cost-to-go using the control sequence

$$\underline{u}_t^*, \underline{u}_{t+1}^*, \underline{u}_{t+2}^*, \dots, \underline{u}_{T-1}^* \quad (3.3.2)$$

and given the value of $k(t-1)$ is defined as

$$\begin{aligned} V(\underline{x}_t, \underline{u}_t, k(t-1), t) \\ = \underline{x}_t^T \underline{Q} \underline{x}_t + \underline{u}_t^T \underline{R} \underline{u}_t \\ + E_{k(t)} \{ V^*(\underline{x}_{t+1}, k(t), t+1) \mid k(t-1) \} \end{aligned} \quad (3.3.3)$$

where $*$ denotes the optimum value and V^* is the optimal value of V .

Then, by dynamic programming

$$\begin{aligned} V^*(\underline{x}_t, k(t-1), t) = \min_{\substack{\underline{u}_t = \phi_t(\underline{x}_t) \\ \underline{u}_t}} \left(\underline{x}_t^T \underline{Q} \underline{x}_t + \underline{u}_t^T \underline{R} \underline{u}_t \right. \\ \left. + E_{k(t)} \{ V^*(\underline{x}_{t+1}, k(t), t+1) \mid k(t-1) \} \right) \end{aligned} \quad (3.3.4)$$

It is proved, from Appendix 3.2, that

$$V^*(\underline{x}_t, k(t-1), t) = \underline{x}_t^T \underline{S}_{k,t} \underline{x}_t \quad (3.3.5)$$

where the $\underline{S}_{k,t}$ are determined by a set of $L+1$ coupled Riccati-like equations (one for each possible configuration):

$$\begin{aligned} \underline{S}_{k,t} = \underline{A}^T \left\{ \sum_{i=0}^L P_{ik} \underline{S}_{i,t+1} \right. \\ \left. - \left[\sum_{i=0}^L P_{ik} \underline{S}_{i,t+1} \underline{B}_i \right] \left[\underline{R} + \sum_{i=0}^L P_{ik} \underline{B}_i^T \underline{S}_{i,t+1} \underline{B}_i \right]^{-1} \right. \\ \left. \cdot \left[\sum_{i=0}^L P_{ik} \underline{B}_i^T \underline{S}_{i,t+1} \right] \right\} \underline{A} + \underline{Q} \end{aligned} \quad (3.3.6)$$

The optimal control, given $k(t-1) = k$, is

$$\begin{aligned} \underline{u}_{k,t}^* &= - \left[\underline{R} + \sum_{i=0}^{I_k} P_{ik} \underline{B}_i^T \underline{S}_{i,t+1} \underline{B}_i \right]^{-1} \\ &\quad \cdot \sum_{i=0}^{I_k} P_{ik} \underline{B}_i^T \underline{S}_{i,t+1} \underline{A} \underline{x}_t \end{aligned} \quad (3.3.7)$$

Writing

$$\underline{u}_{k,t}^* = \underline{G}_{k,t} \underline{x}_t \quad (3.3.8)$$

then

$$\begin{aligned} \underline{G}_{k,t} &= - \left[\underline{R} + \sum_{i=0}^{I_k} P_{ik} \underline{B}_i^T \underline{S}_{i,t+1} \underline{B}_i \right]^{-1} \\ &\quad \cdot \sum_{i=0}^{I_k} P_{ik} \underline{B}_i^T \underline{S}_{i,t+1} \underline{A} \end{aligned} \quad (3.3.9)$$

Thus, $\underline{u}_t^* = \phi_t(\underline{x}_t)$ is a switching gain linear control law which depends on $k(t-1)$. The variable $k(t-1)$ is determined by

$$k(t-1) = i \quad \text{iff} \quad \underline{x}_t = \underline{A} \underline{x}_{t-1} + \underline{B}_i \underline{u}_{t-1} \quad (3.3.10)$$

Note that the $\underline{S}_{i,t}$'s and the optimal gains $\underline{G}_{k,t}$ can be computed off-line and stored. Then, at each time t , the proper gain is selected on-line from $k(t-1)$, using equation (3.3.10), as in Figure 3.1.

3.4 Discussion of Results.

The solution in section 3 is quite complex relative to the structure of the usual linear quadratic solution. Each of the Riccati-like equations (3.3.6) involves the same complexity as the Riccati equation for the linear quadratic solution. In addition, there is the on-line complexity arising from the implementation of gain scheduling. In Chapter 5, a non-switching gain solution will be presented which has an identical on-line structure to that of the linear quadratic

76265AW028

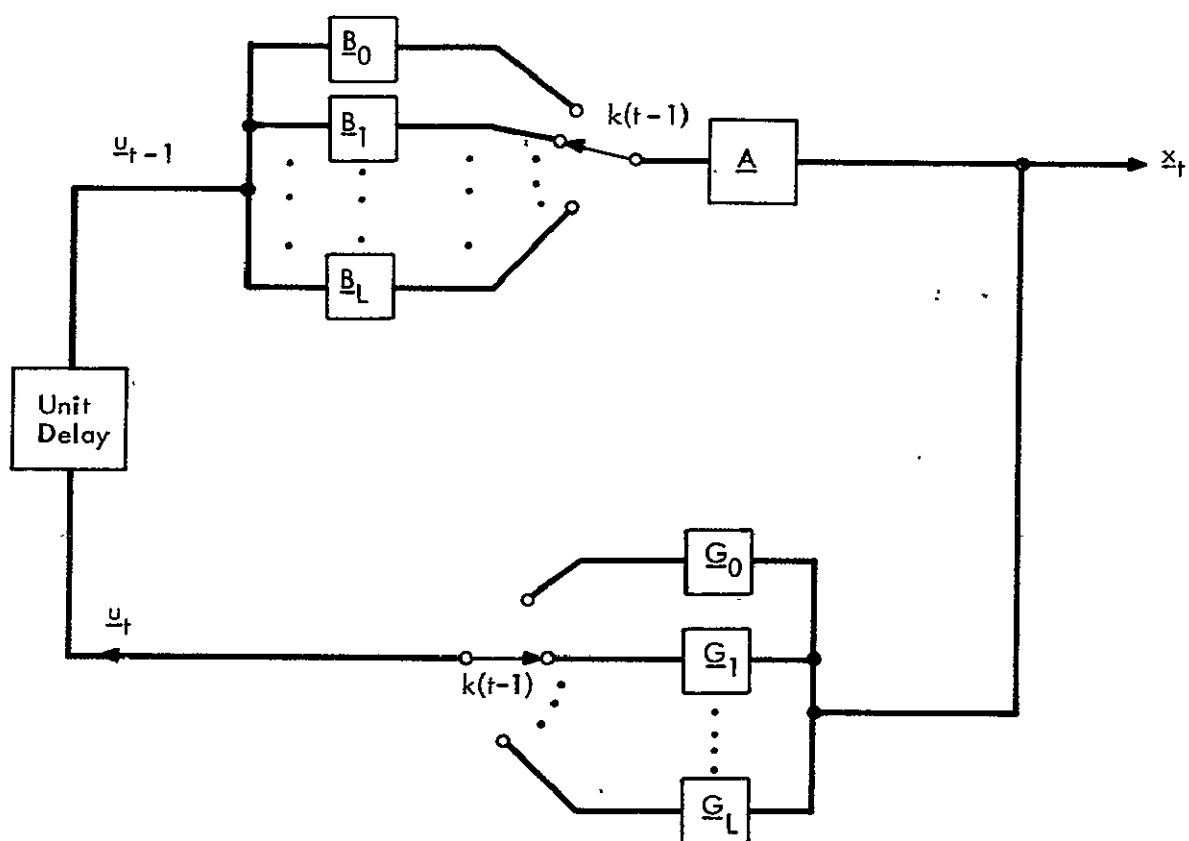

Figure 3.1: The switching gain control law.

solution, but has similar off-line computational complexity to that of the switching gain solution. Depending on the system requirements, either solution could be used; the non-switching gain solution is suboptimal, but requires less on-line complexity. This trade-off may favor the non-switching solution in some cases.

A steady-state solution to equation (3.3.6) may exist, but the conditions for its existence are unknown. The steady-state solution would have the advantage that a time-invariant set of gains result. Thus, only one set of gains need be stored on-line, instead of requiring a set of gains to be stored for each time t . Since the steady-state solution is simply the value to which equation (3.3.6) converges as it is iterated backward in time, at present, the equations can be iterated numerically until either they converge or meet some test of non-convergence. Unlike the non-switching solution presented in Chapter 5, the possibility of limit cycle solutions in the switching gain computations is excluded by the following lemma:

Lemma 1: If the optimal expected cost-to-go at time t is bounded for all t , then equation (3.3.6) converges.

Proof: See Appendix 3.3.

Once again, it is stressed that the existence of a steady-state solution to the switching gain problem establishes a division of system designs into those which are inherently reliable and those which are unreliable. Even though conditions to test for the existence of the steady-state solution are unavailable, software can be used with iteration for the test.

In Section 5, some numerical examples are given to illustrate the switching gain solution.

3.5 Examples.

In this Section, a two-dimensional example is presented with three different switching gain solutions to illustrate the switching gain computational methodology. The computer routines which are used in the calculation of the switching gain solution are listed in the Appendix. The primary subroutine is READY; it calls WEIGHT. Any other routines which are used are from the standard ESL subroutine library. The main program RDYMAIN is used to call READY.

Example 3.1 is a two-dimensional system with four structural states corresponding to the failure modes of two actuators. In this example, failure of an actuator is modeled as an actuator gain of zero. Thus, the four structures are: I) Both actuators working (\underline{B}_0); II) One actuator failed (\underline{B}_1 and \underline{B}_2), and III) Both actuators failed (\underline{B}_3). The system is controllable in all structures except for the structure represented by \underline{B}_3 .

Actuator failures and repairs are assumed to be independent events with probabilities of failure and repair, per unit time, of p_f and p_r , respectively, for both actuators.

In Example 3.1, the matrixes \underline{Q} and \underline{R} are the quadratic weighting matrices for the state \underline{x}_t and the control \underline{u}_t , respectively. The matrix \underline{P} is the Markov transition matrix, which is calculated from knowledge of the system configuration dynamics, represented graphically in Figure 3.2.

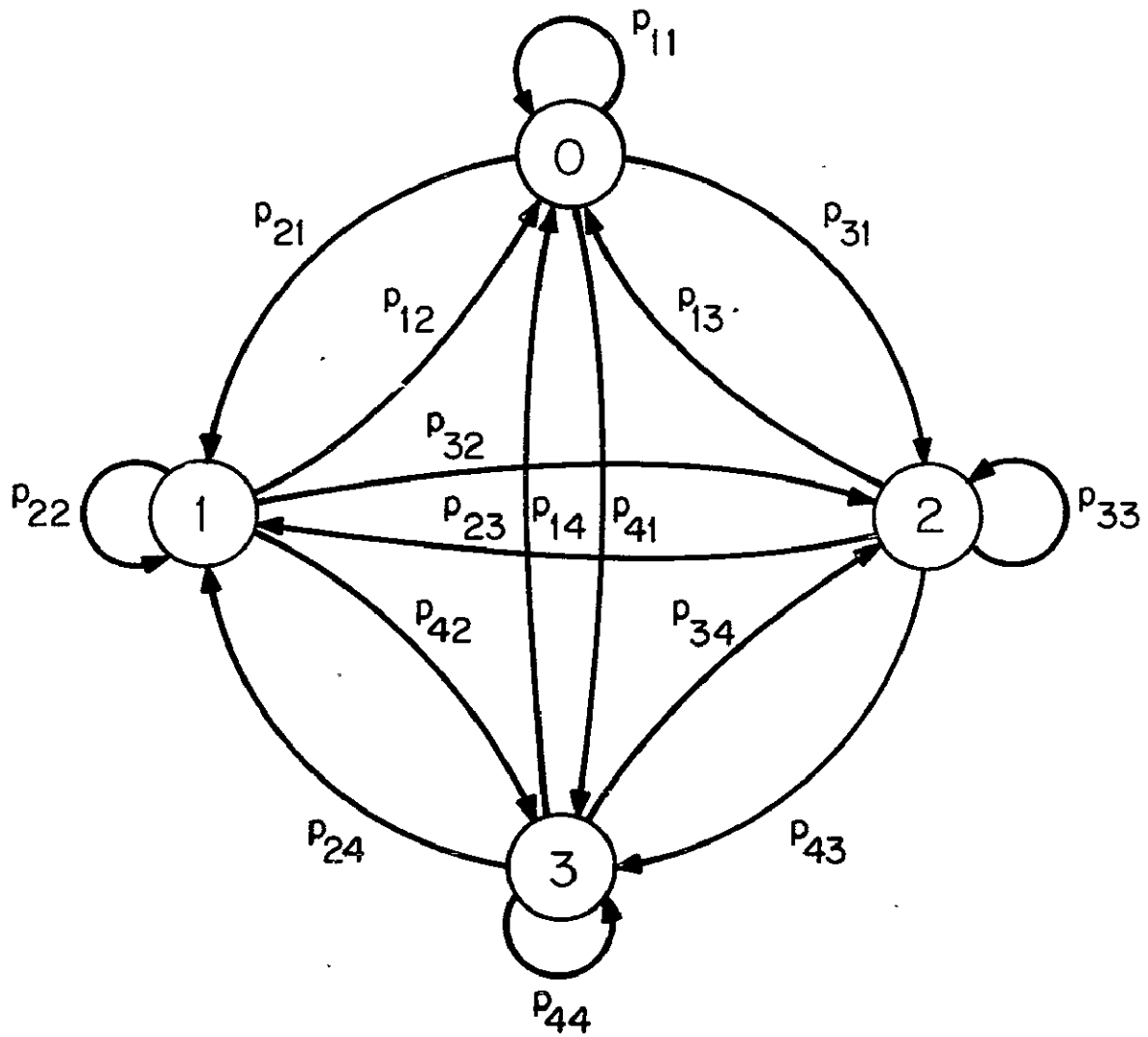

Figure 3.2: Markov transition probabilities for Example 3.1.

There are three Cases to Example 3.1. Each Case assumes a different failure rate and repair rate for the actuators. Case i) has a high probability of failure and a low probability of repair, relative to Cases ii) and iii). The switching gain solution is not convergent for Case i); the gains themselves converge, but the expected costs do not. Only configuration state 0 is stabilized with its corresponding gain, \underline{G}_0 .

Cases ii) and iii) both assume more reliable actuators than does Case i). Both Cases ii) and iii) have convergent switching gain solutions. Therefore, both Cases ii) and iii) represent reliable configuration designs, while Case i) is unreliable. This difference is due entirely to the different component reliabilities. Equivalently, Cases ii) and iii) are stabilized by the switching gain solution, while Case i) is not. Note that in this Example, stabilizability is not equivalent to stability in each configuration state, or robustness. For this example, no robust gain exists because the system is uncontrollable from configuration state 3.

Cases ii) and iii) are also presented in Chapter 5, where their non-switching gain solutions are given. According to the theory, it should be more difficult to stabilize a given system with the non-switching gain than it is with the switching gain, because of the optimality of the switching gain solution. This is demonstrated for this example; in Chapter 5, the non-switching gain solution to Case ii) is not convergent.

Example 3.1:

$$\underline{A} = \begin{bmatrix} 2.71828 & 0.0 \\ 0.0 & .36788 \end{bmatrix}$$

$$\underline{B}_0 = \begin{bmatrix} 1.71828 & 1.71828 \\ -.63212 & .63212 \end{bmatrix}$$

$$\underline{B}_1 = \begin{bmatrix} 0.0 & 1.71828 \\ 0.0 & .63212 \end{bmatrix}$$

$$\underline{B}_2 = \begin{bmatrix} 1.71828 & 0.0 \\ -.63212 & 0.0 \end{bmatrix}$$

$$\underline{B}_3 = \begin{bmatrix} 0.0 & 0.0 \\ 0.0 & 0.0 \end{bmatrix}$$

$$\underline{Q} = \begin{bmatrix} 14. & 8. \\ 8. & 6. \end{bmatrix}$$

$$\underline{R} = \begin{bmatrix} 1.0 & 0.0 \\ 0.0 & 1.0 \end{bmatrix}$$

$$\underline{P} = \begin{bmatrix} 1-2p_f+p_f^2 & (1-p_f)p_r & (1-p_f)p_r & p_r^2 \\ p_f(1-p_f)^2 & 1-p_f-p_r+p_f p_r & p_r p_f & p_r(1-p_r) \\ p_f(1-p_f)^2 & p_r p_f & 1-p_f-p_r+p_f p_r & p_r(1-p_r) \\ p_f^2 & (1-p_r)p_f & (1-p_r)p_f & 1-2p_r+p_r^2 \end{bmatrix}$$

The system dynamics are

$$\underline{x}_{t+1} = \underline{A}\underline{x}_t + \underline{B}_{k(t)}\underline{u}_t \quad \underline{x}_t = [x_{1,t} \quad x_{2,t}]^T$$

$$k(t) \in \{0,1,2,3\}$$

The cost, which is to be minimized, is

$$J = E \left[\sum_{t=0}^{\infty} \underline{x}_t^T \underline{Q} \underline{x}_t + \underline{u}_t^T \underline{R} \underline{u}_t \mid \underline{\pi} \right]$$

Example 3.1, Case i)

$$p_f = .3$$

$$p_r = .7$$

$$\underline{\pi} = \begin{bmatrix} .49 \\ .21 \\ .21 \\ .09 \end{bmatrix} = \begin{bmatrix} \pi_0 \\ \pi_1 \\ \pi_2 \\ \pi_3 \end{bmatrix}$$

82

Non-Convergent; but gains converge:

$$\underline{G}_0 = \begin{bmatrix} -.9636 & 1.094 \times 10^{-6} \\ -.9134 & -5.835 \times 10^{-6} \end{bmatrix}$$

$$\underline{G}_1 = \begin{bmatrix} -.9234 & 1.740 \times 10^{-6} \\ -.8699 & -5.136 \times 10^{-6} \end{bmatrix}$$

$$\underline{G}_2 = \begin{bmatrix} -.8094 & .9186 \times 10^{-6} \\ -1.020 & -4.05 \times 10^{-6} \end{bmatrix}$$

$$\underline{G}_3 = \begin{bmatrix} -.9636 & .7353 \times 10^{-6} \\ -.9134 & -3.923 \times 10^{-6} \end{bmatrix}$$

Stability:

| Configuration | Stable |
|-------------------------|--------|
| 0 (\underline{B}_0) | yes |
| 1 (\underline{B}_1) | no |
| 2 (\underline{B}_2) | no |
| 3 (\underline{B}_3) | no |

Example 3.1, Case ii)

$$p_f = .1, p_r = .9$$

$$\underline{\pi} = \begin{bmatrix} .81 \\ .09 \\ .09 \\ .01 \end{bmatrix} = \begin{bmatrix} \pi_0 \\ \pi_1 \\ \pi_2 \\ \pi_3 \end{bmatrix}$$

Convergent Coupled Riccati Equations:

$$\underline{G}_i = \begin{bmatrix} -.8890 & .04222 \\ -.7752 & -.09914 \end{bmatrix}$$

$$\underline{S}_i = \begin{bmatrix} 25.57 & 8.611 \\ 8.611 & 6.398 \end{bmatrix}$$

for $i = 0, 1, 2, 3$

Stability:

| Configuration | Stable |
|-------------------------|--------|
| 0 (\underline{B}_0) | yes |
| 1 (\underline{B}_1) | no |
| 2 (\underline{B}_2) | no |
| 3 (\underline{B}_3) | no |

Example 3.1, Case iii)

$$p_f = .01, p_r = .98$$

$$\underline{\pi} = \begin{bmatrix} .9799 \\ .009999 \\ .009999 \\ .0001020 \end{bmatrix} = \begin{bmatrix} \pi_0 \\ \pi_1 \\ \pi_2 \\ \pi_3 \end{bmatrix}$$

Convergent Coupled Riccati Equations:

$$\underline{G}_0 = \begin{bmatrix} -.7558 & .1270 \\ -.8073 & -.1786 \end{bmatrix}$$

$$\underline{S}_0 = \begin{bmatrix} 15.88 & 8.105 \\ 8.105 & 6.137 \end{bmatrix}$$

$$\underline{G}_1 = \begin{bmatrix} -.7060 & .1186 \\ -.8441 & -1.723 \end{bmatrix}$$

$$\underline{S}_1 = \begin{bmatrix} 16.06 & 8.074 \\ 8.074 & 6.143 \end{bmatrix}$$

$$\underline{G}_2 = \begin{bmatrix} -.8375 & .1090 \\ -.7543 & -.1669 \end{bmatrix}$$

$$\underline{S}_2 = \begin{bmatrix} 16.31 & 8.199 \\ 8.199 & 6.158 \end{bmatrix}$$

$$\underline{G}_3 = \begin{bmatrix} -.7863 & .1023 \\ -.7926 & -.1619 \end{bmatrix}$$

$$\underline{S}_3 = \begin{bmatrix} 16.54 & 8.170 \\ 8.170 & 6.162 \end{bmatrix}$$

Stability:

| Configuration | Stable |
|-----------------------------|--------|
| 0 (<u>B</u> ₀) | yes |
| 1 (<u>B</u> ₁) | no |
| 2 (<u>B</u> ₂) | no |
| 3 (<u>B</u> ₃) | no |

3.6 Summary.

In this chapter, the optimal solution to the linear control problem with variable actuator configuration was developed. It was shown that the optimal solution uses a linear switching feedback gain which depends on the previous configuration. This configuration is directly computable from the past measurements; this fact allows the development of the switching gain solution by eliminating dual control considerations. The exact measurement of the configuration with one-step delay holds only for the deterministic case, where there is no corruption of the state or control observations by noise.

In Chapter 4, the use of the switching gain methods will be demonstrated for stochastic problems in conjunction with two different forms of identification: Hypothesis testing and dual identification, a technique for "pushing" the control variable out of the noisy region, when the noise is amplitude limited, to obtain an exact identification of the system structure.

CHAPTER 4

EXTENSIONS TO THE STOCHASTIC CASE

4.1 Introduction.

In Chapter 3, the optimal solution to the deterministic linear quadratic control problem with variable actuator configuration was developed. It was also demonstrated that the optimal solution of the general stochastic linear quadratic problem is hopelessly complex in Chapter 2. Therefore, in this Chapter, extensions to the deterministic solution to allow its operation in a stochastic environment will be studied.

From the derivation of the switching gain solution, whenever the structure of the system is known perfectly with one step delay, and if it is assumed that it will be measured perfectly at the next time instant, the optimal solution is the deterministic switching gain solution. In designing a suboptimal control system, a method of identifying the system structure is used, with the assumption that the identification is perfect, and the appropriate deterministic gain is selected.

Two conceptually different methods of structure identification will be presented in this Chapter. The first is classical hypothesis testing. It is the easiest to implement, although extensions to n-step hypothesis testing can be made which are very complex. The second method is labeled dual identification; the expression is used because it takes advantage of the dual effect of the control law to guarantee perfect identification. In this method, a perturbation

(which may or may not be that small) to the deterministic control is introduced which separates the effect of amplitude limited white control noise from that of the system structure. As a worst case control law, this perturbation would be applied at each time instant, but in practice, it would only be applied once every n time instances so that its overall effect on system performance would be lessened.

In the next Section, the system model will be described, and the hypothesis testing identification algorithm will be presented.

4.2 Hypothesis Testing Identification.

The system model used here is the same as in Chapter 3, but with the exception that additive white noise is introduced into the dynamics:

$$\underline{x}_{t+1} = \underline{A}\underline{x}_t + \underline{B}_k(t) u_t + \underline{\xi}_t \quad (4.2.1)$$

For the hypothesis testing identification method, $\underline{\xi}_t$ is assumed to be zero mean white noise with probability distribution $\rho(\underline{\xi})$. It is assumed to be uncorrelated with $k(t)$ and \underline{x}_t . Perfect measurement of the state is retained.

The basic hypothesis testing method is very simple: At each time t , one of $L+1$ hypotheses is chosen, where each hypothesis H_i is

$$H_i : k(t-1) = i \quad (4.2.2)$$

With each hypothesis H_i , there is a probability of H_i being correct, given the measurement \underline{x}_t and the past information: $\pi(t-1|t-1)$, the probability distribution of $k(t-1)$, given the measurements through \underline{x}_{t-1} . Then the updated probability (see Appendix 2) $\pi_i(t-1|t)$, the probability of $k(t-1) = i$, given all measurements through \underline{x}_t , is

given by

$$\pi_i(t-1|t) = \frac{\rho(\underline{x}_t - \underline{A}\underline{x}_{t-1} - \underline{B}_i \underline{u}_{t-1}) \pi_i(t-1|t-1)}{\sum_{j=0}^I \rho(\underline{x}_t - \underline{A}\underline{x}_{t-1} - \underline{B}_j \underline{u}_{t-1}) \pi_j(t-1|t-1)} \quad (4.2.3)$$

Hypothesis H_i is assumed to be correct if

$$\pi_i(t-1|t) > \pi_j(t-1|t) \quad \text{for all } j \neq i \quad (4.2.4)$$

Ties are resolved arbitrarily. Then, given the correct hypothesis H_i , the corresponding deterministic optimal switching gain is used to compute the control at time t

$$\underline{u}_t = \underline{G}_{i,t} \underline{x}_t \quad (4.2.5)$$

as in equations (3.3.8) and (3.3.9).

The probability distribution is then propagated with the Markov chain equation

$$\underline{\pi}(t|t) = \underline{P} \underline{\pi}(t-1|t) \quad (4.2.6)$$

and the process repeats.

This algorithm can work well if there are significant differences in the effect of the control variable between configurations. When the differences are slight, a mistracking will result until the errors are large enough to be detected through equation (4.2.3). The method does not exploit any of the dual effect of the control variable on the measurement of the configuration. The method presented next does use the dual effect to identify the correct structure. Analytically, it cannot be said which method is best, as the optimal control law will lie somewhere between the two. It is possible to extend the hypothesis testing procedure to n -step hypothesis testing where a hypothesis is made about the last n values of $k(t)$ and is then tested.

Since this investigation is not within the primary scope of this research, it is left as an open problem for future research. It is also possible that a combination of hypothesis testing and dual identification may be used to gain some of the advantages of both methods; dual identification yields fast identification of the correct structure, while hypothesis testing does not sacrifice control of the system while there is a high probability that the structure is correctly identified.

4.3 Dual Identification.

The underlying concept of dual identification is to periodically change the control in order to increase the accuracy of identification of the structure. In the limiting case, the control is changed enough to guarantee perfect identification of the current structure with the next observation. For this case only amplitude limited noise is considered. The system model is

$$\underline{x}_{t+1} = \underline{A} \underline{x}_t + \underline{B}_{k(t)} \underline{u}_t + \underline{M} \underline{\xi}_t \quad (4.3.1)$$

where $\underline{\xi}_t$ is ℓ -dimensional white noise which takes on values in the unit sphere with distribution $\rho(\underline{\xi})$ and is uncorrelated with \underline{x}_t and $k(t)$. \underline{M} is an $n \times \ell$ matrix which defines the ellipsoid in \mathbb{R}^n which contains $\underline{M} \underline{\xi}_t$.

Normally, if no identification were to be performed, and if $k(t-1)$ were known, the optimal deterministic switching gain $\underline{G}_{k(t-1),t}$ from equation (3.3.9) would be used to compute \underline{u}_t^* .

$$\underline{u}_t^* = \underline{G}_{k(t-1),t} \underline{x}_t \quad (4.3.2)$$

In dual identification, the goal is to compute a gain offset $\underline{u}_{1,t}$

such that when the control

$$\underline{u}_t = \underline{u}_t^* + \underline{u}_{1,t} \quad (4.3.3)$$

is applied to the system, identification of the structure $k(t)$ with the observation \underline{x}_{t+1} is guaranteed. To accomplish this, note that, for a given \underline{B}_k , \underline{x}_{t+1} will be in a bounded convex set determined by \underline{B}_k and \underline{M} . Thus,

$$\underline{x}_{t+1} - \underline{A}\underline{x}_t = \underline{B}_k \underline{u}_t + \underline{M}\underline{\xi}_t \quad (4.3.4)$$

and $\underline{\xi}_t$ can be any element in the unit sphere $S(R^{\ell})$. Therefore, perfect identification of $k(t)$ is guaranteed if no two of the domains of \underline{x}_{t+1} corresponding of the \underline{B}_k 's have a non-empty open intersection. That is, the following condition must be satisfied for each pair of \underline{B}_{k_i} 's and every $\underline{\xi}_1$ and $\underline{\xi}_2$ of $S(R^{\ell})$:

$$(\underline{B}_{k_1} - \underline{B}_{k_2})\underline{u}_t + \underline{M}(\underline{\xi}_1 - \underline{\xi}_2) \neq 0 \quad (4.3.5)$$

This condition is the same as

$$\begin{aligned} & \| \underline{M}^{\#} (\underline{B}_{k_1} - \underline{B}_{k_2})\underline{u}_t \| > 2 \\ & \text{if } (\underline{B}_{k_1} - \underline{B}_{k_2})\underline{u}_t \notin N(\underline{M}) \end{aligned}$$

otherwise,

$$(\underline{B}_{k_1} - \underline{B}_{k_2})\underline{u}_t \neq 0 \quad (4.3.6)$$

where $\underline{M}^{\#}$ is the generalized inverse of \underline{M} and $N(\underline{M})$ is the nullspace of \underline{M} . Note that the inequality of (4.3.6) can be relaxed to equality, since the intersection of the two domains of \underline{x}_{t+1} would only be at the point of tangency, a set of measure zero in either domain.

The objective is to choose $\underline{u}_{1,t}$ such that (4.3.6) is satisfied for all pairs \underline{B}_{k_1} and \underline{B}_{k_2} in the reachable subset of all actuator

configurations. The reachable subset refers to the subset of configurations \underline{B}_i which have a non-zero probability of occurrence at time t , given that the configuration was $\underline{B}_{k(t-1)}$ at $t-1$. This is the same as the condition that

$$\begin{aligned} \underline{B}_i & \text{ is in the reachable subset from } \underline{B}_{k(t-1)} \\ & \text{ if } P_{ik(t-1)} > 0 \end{aligned} \quad (4.3.7)$$

Suppose that there are J configurations in the reachable subset from $\underline{B}_{k(t-1)}$. Then there are $J(J+1)/2$ pairs of configurations for which condition (4.3.6) must be satisfied. Also, since $\underline{u}_{1,t}$ affects the state \underline{x}_{t+1} , it is reasonable to minimize its effect. Therefore, since the effect of $\underline{u}_{1,t}$ is modified by $\underline{B}_{k(t)}$, it is reasonable to minimize the norm of $\underline{u}_{1,t}$. Thus, the minimization problem is formulated subject to the constraints (4.3.6).

$$\begin{aligned} \min & \|\underline{u}_{1,t}\|^2 \\ & \underline{u}_{1,t} \\ \text{subject to} & \\ 4 - & \|\underline{D}_k [\underline{u}_t^* + \underline{u}_{1,t}]\|^2 \leq 0 \end{aligned} \quad (4.3.8)$$

where

$$\underline{D}_{i+(j-1)*J} = \underline{M}^\# (\underline{B}_i - \underline{B}_j) \quad (4.3.9)$$

Formulating this as a nonlinear programming problem, the Hamiltonian is

$$\begin{aligned} H(\underline{u}_{1,t}, \underline{\lambda}) = & \|\underline{u}_{1,t}\|^2 + \sum_k \lambda_k (4 - \|\underline{D}_k [\underline{u}_t^* + \underline{u}_{1,t}]\|^2) \\ & \lambda_k \geq 0 \end{aligned} \quad (4.3.10)$$

$$\lambda_k = 0 \quad \text{if} \quad 4 - \|\underline{D}_k [\underline{u}_t^* + \underline{u}_{1,t}]\|^2 < 0 \quad (4.3.11)$$

Differentiating H with respect to $\underline{\lambda}$, and solving for $\underline{u}_{1,t}$ as a function of \underline{u}_t^* and the parameter $\underline{\lambda}$,

$$\frac{\partial H}{\partial \underline{u}_{1,t}} = 0 = 2\underline{u}_{1,t} - \sum_k 2\lambda_k \underline{D}_k^T \underline{D}_k [\underline{u}_t^* + \underline{u}_{1,t}] \quad (4.3.12)$$

or,

$$\underline{u}_{1,t} = [\underline{I} - \sum_k \lambda_k \underline{D}_k^T \underline{D}_k]^{-1} \sum_k \lambda_k \underline{D}_k^T \underline{D}_k \underline{u}_t^* \quad (4.3.13)$$

Now, using (4.3.13) in the constraint equation (4.3.11)

$$4 - \left\| \underline{D}_k [\underline{I} + [\underline{I} - \sum_k \lambda_k \underline{D}_k^T \underline{D}_k]^{-1} \sum_k \lambda_k \underline{D}_k^T \underline{D}_k] \underline{u}_t^* \right\|^2 \leq 0 \quad (4.3.14)$$

Noting that

$$[\underline{I} - \lambda [\underline{I} + \lambda \underline{D}^T \underline{D}]^{-1} \underline{D}^T \underline{D}] = [\underline{I} + \lambda \underline{D}^T \underline{D}]^{-1} \quad (4.3.15)$$

then (4.3.14) simplifies to

$$4 - \left\| \underline{D}_k [\underline{I} - \sum_k \lambda_k \underline{D}_k^T \underline{D}_k]^{-1} \underline{u}_t^* \right\| \leq 0 \quad (4.3.16)$$

and if (4.3.16) is a strict inequality, then $\lambda_k = 0$. In general, a numerical algorithm must be used to solve for $\underline{\lambda}$ in the set of equations (4.3.16); this can be a major drawback to the application of this methodology if the on-line computer resources are unavailable. Although the computational burden of this technique is a disadvantage, dual identification would most likely be implemented in combination with a hypothesis testing algorithm. Dual identification would then form a test to be performed on the system after some interval of time to ensure that the hypothesis testing algorithm correctly tracked the configuration.

4.4 Examples.

In this Section, the one-dimensional example of Chapter 2, Section 2 is implemented with additive white noise applied to the control input. Three suboptimal control algorithms derived from this Chapter are implemented: Hypothesis testing, dual identification, and hypothesis testing in combination with dual identification, which is utilized every fifth time instant. The purpose of this example is to illustrate the degrading effect of the dual identification algorithm on the system state.

The principle subroutine used to generate the computer simulations of Example 4.1 is SWITCH; it is listed in the Appendix. SWITCH calls FIG and UCALC, also in the Appendix; any other routines which are used are in the ESL subroutine library.

The system in Example 4.1 has two structures, represented by the matrices \underline{B}_0 ($b = 2.$) and \underline{B}_1 ($1/b = .5$); the Markov transition probabilities are given by the matrix \underline{P} . The switching gain solution was calculated using the software described in Chapter 3, Section 5. Case i) of the Example corresponds to the hypothesis testing methodology described in Section 2. The additive white noise was amplitude-limited with zero mean and variance $\bar{\epsilon} = 1$. Case ii) of the example demonstrates the performance degradation due to the exclusive use of dual identification. Note that the variation among the values of the state and control are larger than in Case i). The advantage of dual identification is that, for amplitude-limited white noise, perfect identification of the system structure with one-step delay is guaranteed. In Case iii), hypothesis testing is used four-fifths of the time to partially avoid the degradation

due to dual identification. The control is more effective in Case iii) than in Case ii); however, for this example, it is not clear that the use of dual identification one-fifth of the time is warranted, since a performance degradation of Case iii) over Case i) is still evident in this particular simulation. More simulation would have to be carried out before the proper ratio of the use of hypothesis testing to the use of dual identification could be determined.

Example 4.1:

$$A = 1.414$$

$$B_0 = 2.000 \quad B_1 = .5000$$

$$Q = 3.000 \quad R = 1.000$$

$$P = \begin{bmatrix} .7 & .3 \\ .3 & .7 \end{bmatrix}$$

Switching Gain Deterministic Solution:

$$G_0 = -.7569$$

$$G_1 = -1.008$$

The system dynamics are

$$x_{t+1} = Ax_t + B_{k(t)}u_t$$

$$k(t) \in \{0,1\}$$

The cost function which was minimized is

$$J = E \left[\sum_{t=0}^{\infty} Qx_t^2 + Ru_t^2 \mid \underline{\pi} \right]$$

where

$$\underline{\pi} = \left[\frac{1}{2} \quad \frac{1}{2} \right]^T$$

Structural transitions are of the form

$$B_0 \begin{array}{c} \xrightarrow{.3} \\ \xleftarrow{.3} \end{array} B_1$$

When dual identification was employed, the control was set to

$$u_t = 1.25(\text{sign}(u_t^*))$$

This control was the minimum value required to establish perfect identification.

0-2

i) Hypothesis Testing

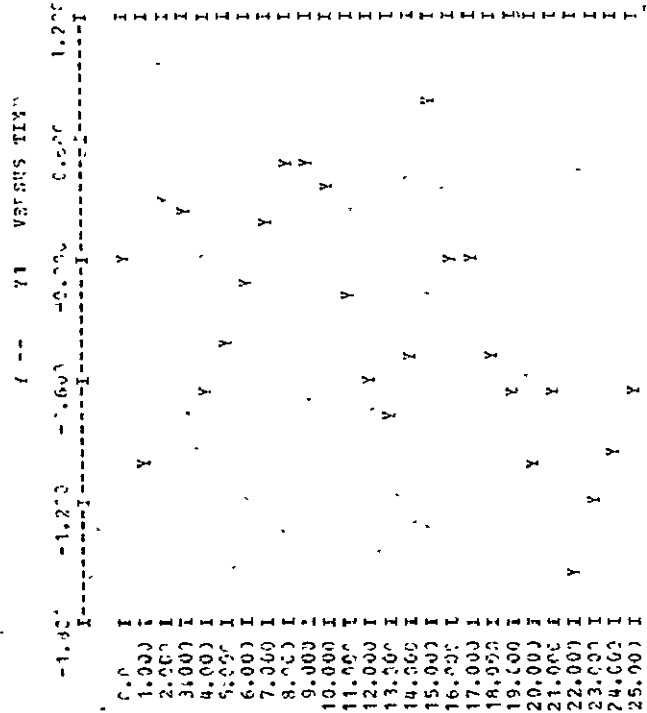

Simulation response of state x_1

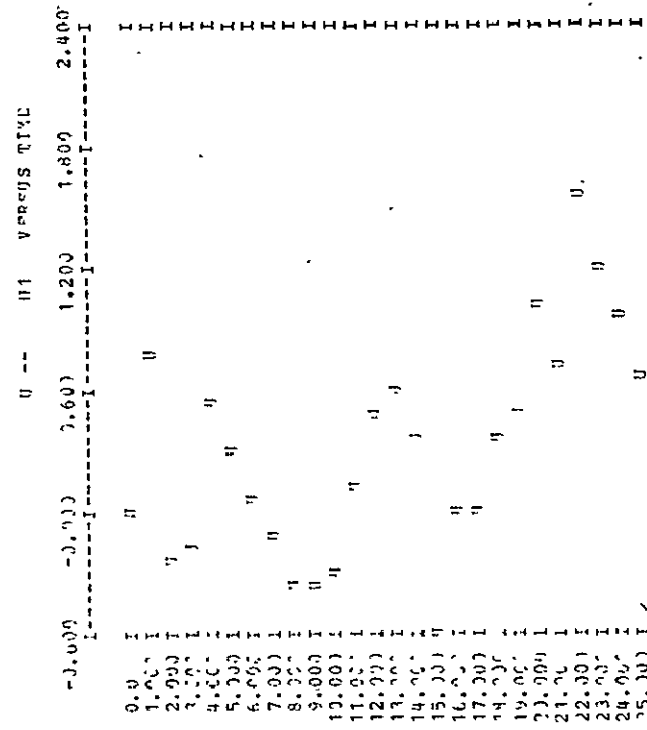

Control u_1 using hypothesis testing

ORIGINAL PAGE IS OF POOR QUALITY

ii) Dual Identification

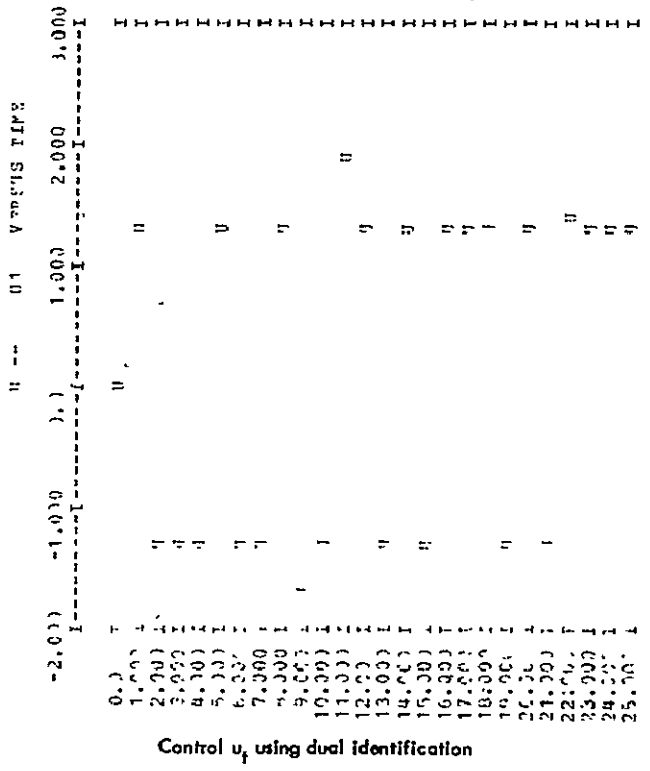
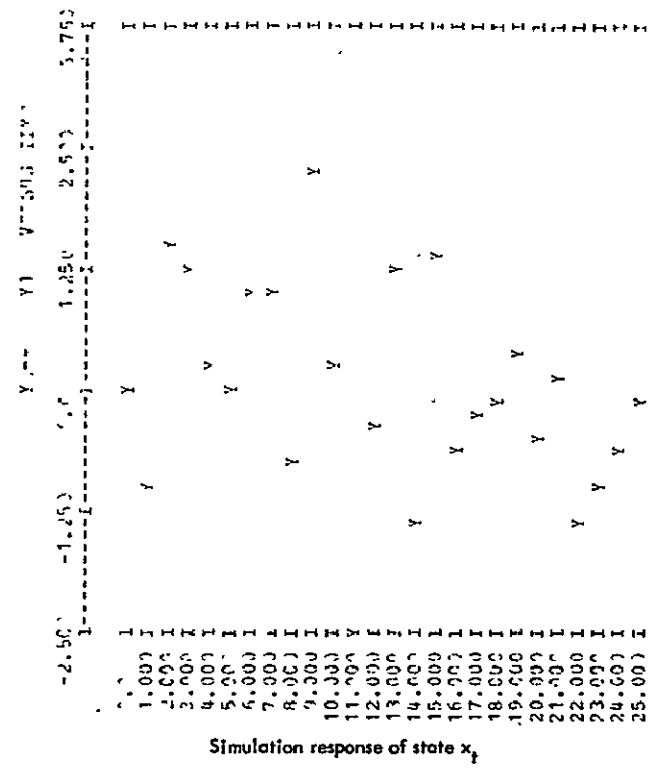

iii) Hypothesis testing and Dual Identification

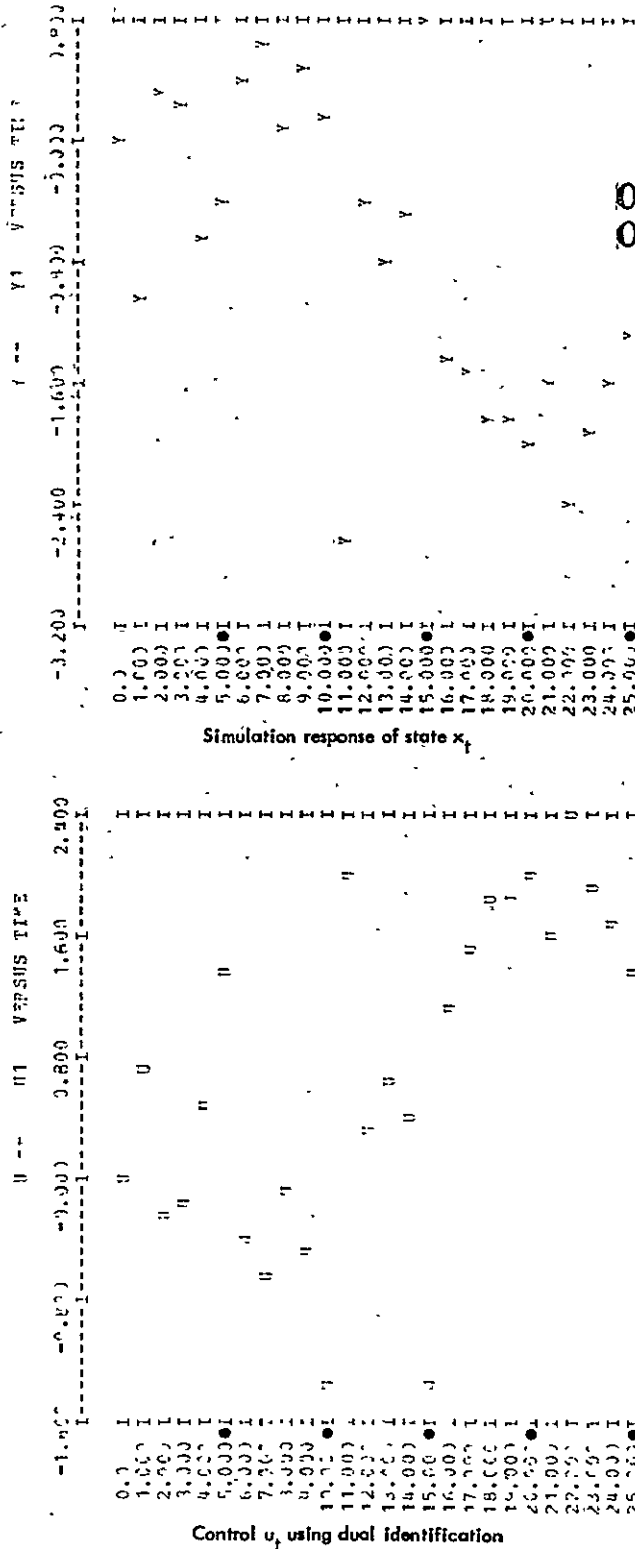

ORIGINAL PAGE IS
OF POOR QUALITY

4.5 Summary.

In this Chapter, two methods have been proposed to extend the deterministic optimal switching gain solution of Chapter 3 to the stochastic case. The two methods represent the two fundamental concepts of identification: Estimation and dual control. The optimal stochastic control law, if it could be computed, would rely on both concepts, using estimation when the control variable is large (and the state is far from the origin) and dual control to enhance estimation when the control and state variables are small.

In the dual identification technique presented here, control is sacrificed to obtain an exact observation of the structure. Thus, the system response would be roughly periodic, with the state being driven away from the origin in order to obtain an accurate estimate of the configuration, and decaying back toward zero between identifications. In the period when the control is not modified, hypothesis testing would be used to track the configuration.

CHAPTER 5

THE NON-SWITCHING GAIN SOLUTION

5.1 Introduction

In the previous two chapters, the switching gain solution was developed and studied. In this chapter, attention will be focused on obtaining a constant, robust, or non-switching gain which solves a variable actuator configuration linear quadratic control problem, with minimum cost for this class of solutions. It must be stressed that this is a suboptimal solution; for the deterministic case, Chapter 3 gives the optimal solution. The interest in this chapter lies in determining a sequence of gains, for a linear control law, which do not switch in response to the detection of a change in system structure. For instance, it may be desirable to ensure the stability of a control system under certain types of failure without creating the complexity necessary to detect those failures and compensate for them, as is done in the switching gain solution.

This class of solutions is related to the overall robustness problem where fault-tolerant control systems are desired. Although not formulated in this manner, the research described in this Chapter, as in Chapter 3, is readily extendable to system with variable system matrices as well; i.e., where the system can be represented as a set of possible structures $(\underline{A}_k, \underline{B}_k)$ over some suitable index, even though this class of problems is not as directly related to the underlying

reliability theme of this report.

Non-switching gain solutions to the variable actuator configuration class of problems can be obtained in different mathematical ways. Problem A of Section 3 is reformulated as a deterministic control problem (Problem AE), and is solved using the necessary conditions of the Matrix Minimum Principle [Athans,41] in Section 5. Unfortunately this approach, although yielding the necessary conditions for an optimum, does not allow an analytic solution. Therefore, in Section 6, a second problem (Problem B) is formulated and solved using dynamic programming.

Section 7 is by far the most detailed and one of the most important sections of the report, along with Sections 8 and 9. In Section 7, the concepts of stability and cost-stability are defined and are used to prove an equivalence between the infinite-time versions of Problems AE and B. In Subsection 7.6, the steady-state solutions for both problems are defined. Unfortunately, nothing in the mathematics appears to rule out the possibility of limit cycles in the infinite-time solution; this is discussed in Subsection 7.7. When the constant steady-state solutions to the two problems exist, it is proved in Section 8 that they are identical. This is a very important result, as it allows the steady-state solution of a complex two-point boundary value problem which is much more tractable.

In Section 9, it is demonstrated that the general robustness problem for linear systems (where one wishes to determine a single stabilizing

gain for a set of linear systems) is solved in this framework for the class of systems with variable actuator configurations. Examples of both the non-switching solution to Problem B and the robustness result are given in Section 10, and a chapter summary in Section 11.

5.2 Problem Statement.

The objective of the research described in this Chapter is to form a methodology which will be used to compute apriori a gain G (either time-varying or steady-state) which minimizes the expectation of the quadratic performance index over a set of linear systems with actuator variation and known transition probabilities of structural change (Problem A). The necessary conditions for minimization are given which this optimal gain must satisfy; it is shown that these conditions result in a complex two-point boundary value problem.

A second optimization problem is formulated which is based on the restriction to non-learning control laws which are precomputed; i.e., it is assumed that the control law cannot benefit from knowledge of its past. Although this formulation appears to be much weaker than that of Problem A, it is shown in Theorem 2 that if steady-state solutions to the two problems exist, then the steady-state solution to Problem A is stabilizing (in the sense that the mean square value of the trajectory is exponentially bounded) if and only if the steady-state solution to Problem B yields a system which is exponentially stable. This result is very significant, in that a Corollary to this

Theorem solves the problem of finding a robust gain for a set of linear systems and yields an explicit procedure for its calculation.

The last Theorem (Theorem 3) of the Chapter proves that the steady-state solutions to the two optimization problems are identical. This implies that not only does the procedure mentioned above determine a robust gain if and only if such a gain exists, but also that the steady-state gain is optimal with respect to the specified quadratic cost criterion.

5.3 Problem A.

Consider the system

$$\underline{x}_{t+1} = \underline{A}\underline{x}_t + \underline{B}_{k(t)}\underline{u}_t \quad (5.3.1)$$

where

$$\underline{x}_t \in R^n \quad (5.3.2)$$

$$\underline{u}_t \in R^m \quad (5.3.3)$$

$$k(t) \in I = \{0, 1, 2, \dots, L\} \quad (5.3.4)$$

I is an indexing set for the possible actuator structures $\{\underline{B}_k\}_{k \in I}$,

where

$$\underline{B}_k \in R^{n \times m} \quad (5.3.5)$$

$k(t)$ is a random variable with sufficient statistics given by the

Markov transition probabilities p_{ij} , where the matrix

$$\underline{P} = (p_{ij}) \quad (5.3.6)$$

is a stochastic matrix, and the initial probability distribution is

$$\underline{\pi}_0 = \underline{\delta}_i \quad * \quad (5.3.7)$$

Since $k(t)$ is assumed to be a Markov chain, the probability vector $\underline{\pi}_t$ is propagated in time by

$$\underline{\pi}_{t+1} = \underline{P} \underline{\pi}_t \quad (5.3.8)$$

where there is no real-time observation with which to update $\underline{\pi}_t$.

Consider the structure space $\{B_k\}_{k \in I}$ indexed by I . Define the structural trajectory \bar{x}_T to be a sequence of element $k(t)$ in I which select a specific structure $B_{k(t)}$ at time t ,

$$\bar{x}_T = (k(0), k(1), \dots, k(T-1)) \quad (5.3.9)$$

The structural trajectory \bar{x}_T is a random variable with probability of occurrence generated from the Markov equation (5.3.8).

$$p(\bar{x}_T) = \prod_{t=0}^{T-1} \pi_{k(t), t} \quad (5.3.10)$$

where the control interval is

$$\{0, 1, 2, \dots, T-1, T\} \quad (5.3.11)$$

for the finite time problem with terminal time T . Then for a given state and control trajectory $(\underline{x}_t, \underline{u}_t)_{t=0}^{T-1}$ generated by (5.3.1) and \bar{x}_T from a sequence of controls $(\underline{u}_t)_{t=0}^{T-1}$, the cost index is to be the standard quadratic cost criterion

$$J_T(\bar{x}_T, (\underline{x}_t, \underline{u}_t)_{t=0}^{T-1}) = \sum_{t=0}^{T-1} \underline{x}_t^T \underline{Q} \underline{x}_t + \underline{u}_t^T \underline{R} \underline{u}_t + \underline{x}_T^T \underline{Q} \underline{x}_T \quad (5.3.12)$$

The admissible controls are restricted to be of the linear feedback form

$$\underline{u}_t = \underline{G}_t \underline{x}_t \quad (5.3.13)$$

* i.e., $\underline{\pi}_0 = (1 \ 0 \ \dots \ 0)$ or $(0 \ 1 \ 0 \ \dots \ 0)$ or ... $(0 \ 0 \ \dots \ 0 \ 1)$.

where the gain matrix \underline{G}_t is restricted to be a function only of time and the initial conditions; i.e., it cannot depend on \underline{x}_t . The objective is to minimize over the set of admissible controls the expectation of (5.3.12), where the expectation is taken over the set of possible structural trajectories

$$\underline{x}_T \in \prod_T I \quad (5.3.14)$$

and the set of initial conditions \underline{x}_0 .

Thus, the optimal control law $\underline{u}_t^* = \underline{G}_t^* \underline{x}_t$ should minimize the cost

$$\begin{aligned} J_T &= E[J_T | \underline{\pi}_0] \\ &= E \left[\sum_{t=0}^{T-1} \underline{x}_t^T \underline{Q} \underline{x}_t + \underline{u}_t^T \underline{R} \underline{u}_t + \underline{x}_T^T \underline{Q} \underline{x}_T \mid \underline{\pi}_0 \right] \end{aligned} \quad (5.3.15)$$

over the set of admissible controls.

Since the structure of $\underline{u}_t = \underline{G}_t \underline{x}_t$ is fixed, the problem is equivalent to minimizing, in an open-loop sense, the cost function

$$E[J_T | \underline{\pi}_0] = E \left[\sum_{t=0}^{T-1} \underline{x}_t^T \underline{Q} \underline{x}_t + \underline{x}_t^T \underline{G}_t^T \underline{R} \underline{G}_t \underline{x}_t + \underline{x}_T^T \underline{Q} \underline{x}_T \mid \underline{\pi}_0 \right] \quad (5.3.16)$$

with respect to the gain matrix \underline{G}_t , $t=0,1,\dots,T-1$. Equation (5.3.16) is simply obtained by substituting equation (5.3.13) into equation (5.3.14).

5.4 The Method of Solution.

The matrix minimum principle [Athans,41] will be used to determine the necessary conditions for the existence of \underline{u}_t^* (or equivalently, \underline{G}_t^*). To solve the problem using the matrix minimum principle, the

formulation presented in the last section must be converted into an equivalent deterministic problem. For this purpose, let the initial state \underline{x}_0 be a zero mean random variable which is independent of any structure. Let

$$\underline{\Sigma}_0 = E[\underline{x}_0 \underline{x}_0^T | \underline{\pi}_0] = E[\underline{x}_0 \underline{x}_0^T] \quad (5.4.1)$$

be the covariance matrix of \underline{x}_0 .

Defining the covariance of \underline{x}_t as

$$\underline{\Sigma}_t \triangleq E[\underline{x}_t \underline{x}_t^T | \underline{\pi}_0] \quad (5.4.2)$$

then, by direct calculation, we obtain

$$\begin{aligned} \underline{\Sigma}_t &= \sum_{i_{t-1}=0}^L \sum_{i_{t-2}=0}^L \cdots \sum_{i_0=0}^L P_{i_{t-1} i_{t-2}} P_{i_{t-2} i_{t-3}} \cdots P_{i_1 i_0} \underline{\pi}_{i_0,0} \\ &\cdot \left[\prod_{j=0}^{t-1} (\underline{A} + \underline{B}_{i_j} \underline{G}_j) \right] \underline{\Sigma}_0 \left[\prod_{j=0}^{t-1} (\underline{A} + \underline{B}_{i_j} \underline{G}_j) \right]^T \end{aligned} \quad (5.4.3)$$

Similarly, if we define

$$\underline{\Sigma}_{i,t} = E[\underline{x}_t \underline{x}_t^T | k(t-1)=i, \underline{\pi}_0] \quad (5.4.4)$$

then, we deduce that

$$\begin{aligned} \underline{\Sigma}_{i,t} &= \frac{1}{\pi_{i_{t-1}}} \sum_{i_{t-2}=0}^L \sum_{i_{t-3}=0}^L \cdots \sum_{i_0=0}^L P_{i i_{t-2}} P_{i_{t-2} i_{t-3}} \cdots P_{i_1 i_0} \\ &\cdot \pi_{i_0,0} (\underline{A} + \underline{B}_{i_{t-1}} \underline{G}_{t-1}) \left[\prod_{j=0}^{t-2} (\underline{A} + \underline{B}_{i_j} \underline{G}_j) \right] \underline{\Sigma}_0 \\ &\cdot \left[\prod_{j=0}^{t-2} (\underline{A} + \underline{B}_{i_j} \underline{G}_j) \right]^T (\underline{A} + \underline{B}_{i_{t-1}} \underline{G}_{t-1})^T \end{aligned} \quad (5.4.5)$$

The matrix $\underline{\Sigma}_{i,t}$ can be defined recursively as

$$\underline{\Sigma}_{j,t+1} = \frac{1}{\pi_{j_t}} \sum_{i=0}^{L-1} p_{ji} \pi_{i_{t-1}} (\underline{A} + \underline{B}_j \underline{G}_t) \underline{\Sigma}_{i,t} (\underline{A} + \underline{B}_j \underline{G}_t)^T \quad (5.4.6)$$

for $t > 1$.

$$\underline{\Sigma}_{j,1} = (\underline{A} + \underline{B}_j \underline{G}_0) \underline{\Sigma}_0 (\underline{A} + \underline{B}_j \underline{G}_0)^T \quad (5.4.7)$$

and the relation

$$\underline{\Sigma}_t = \sum_{i=0}^{L-1} \pi_{i_{t-1}} \underline{\Sigma}_{i,t}, \quad t > 0 \quad (5.4.8)$$

is obvious from direct calculation.

Remark 1: At this stage, an equivalent deterministic problem (Problem AE) will be defined with state $(\underline{\Sigma}_{i,t})_{i=0}^{L-1}$ for $t > 0$ and state $\underline{\Sigma}_0$ at $t = 0$. The system dynamics are then defined by equations (5.4.6) and (5.4.7).

Definition (Problem AE): For the system with matrix state $(\underline{\Sigma}_{i,t})_{i=0}^{L-1}$ for $t > 0$ and $\underline{\Sigma}_0$ for $t = 0$ with dynamical equations (5.4.6) and (5.4.7) and matrix control \underline{G}_t , minimize the equivalent deterministic cost over $(\underline{G}_t)_{t=0}^{T-1}$:

$$\begin{aligned} J_T^E &= E_{\underline{x}, \underline{x}_0} \left[\sum_{t=0}^{T-1} \underline{x}_t^T \underline{Q} \underline{x}_t + \underline{x}_t^T \underline{G}_t^T \underline{R} \underline{G}_t \underline{x}_t \right. \\ &\quad \left. + \underline{x}_T^T \underline{Q} \underline{x}_T \mid \underline{\Sigma}_0, \pi_0 \right] \\ &= \sum_{t=0}^{T-1} \text{tr}[\underline{\Sigma}_t (\underline{Q} + \underline{G}_t^T \underline{R} \underline{G}_t)] + \text{tr}[\underline{\Sigma}_T \underline{Q}] \end{aligned} \quad (5.4.9)$$

Note that since the expectation in equation (5.3.13) is over all structural trajectories \bar{x} and the initial \underline{x}_0 also,

$$J_T^E = J_T \quad (5.4.10)$$

The symbol J_T will be used exclusively in the future. The one-stage, or instantaneous, cost at time t is

$$J_T^t = \text{tr}[\underline{\Sigma}_t (\underline{Q} + \underline{G}_t^T \underline{R} \underline{G}_t)] \quad (5.4.11)$$

Problem AE is completely deterministic in the state $(\underline{\Sigma}_{i,t})_{i=0}^L$, $\underline{\Sigma}_0$ and control \underline{G}_t .

At this point, the minimization will be decomposed into two parts using the Principle of Optimality [Athans and Falb, 21]. The first minimization is over the interval $\{1, 2, \dots, T-1\}$, and for this the matrix minimum principle will be used. The resulting solution will depend in general on the choice of \underline{G}_0 and on the initial conditions $\underline{\Sigma}_0$ and $\underline{\pi}_0$.

Let $V^*(\underline{G}_0)$ be the optimal cost resulting from the use of \underline{G}_0 and the optimal sequence \underline{G}_1^* , \underline{G}_2^* , \dots , \underline{G}_{T-1}^* for the interval $\{1, 2, \dots, T\}$. The second minimization is then over \underline{G}_0 of the cost

$$J_T = \text{tr}[\underline{\Sigma}_0 (\underline{Q} + \underline{G}_0^T \underline{R} \underline{G}_0)] + V^*(\underline{G}_0) \quad (5.4.12)$$

The Principle of Optimality states that these two minimizations result in the minimizing sequence $(\underline{G}_t^*)_{t=0}^{T-1}$ for Problem AE.

From [Athans,41], the Hamiltonian for the minimization over $\{1,2,\dots,T-1\}$ is

$$\begin{aligned}
 & H((\underline{\Sigma}_{i,t})_{i=0}^L, (\underline{S}_{j,t+1})_{j=0}^L, \underline{G}_t) \\
 & = \text{tr} \sum_{i=0}^L \pi_{i,t-1} \underline{\Sigma}_{i,t} (\underline{Q} + \underline{G}_t^T \underline{R} \underline{G}_t) \\
 & + \text{tr} \left[\sum_{j=0}^L \left(\frac{1}{\pi_{j,t}} \sum_{i=0}^L p_{ji} \pi_{i,t-1} (\underline{A} + \underline{B}_j \underline{G}_t) \underline{\Sigma}_{i,t} (\underline{A} + \underline{B}_j \underline{G}_t)^T \right) \underline{S}_{j,t+1} \right] \\
 & \text{for } t \in \{1,2,3,\dots,T-1\} \tag{5.4.13}
 \end{aligned}$$

where the costate matrix is $(\underline{S}_{j,t+1})_{j=0}^L$.

Remark: We have now formulated Problem AE-1, which minimizes the accumulated cost over the interval $\{1,2,\dots,T\}$ with respect to the sequence $(\underline{G}_t)_{t=1}^{T-1}$ using the matrix minimum principle and results in the optimum cost, given $\underline{G}_0, V^*(\underline{G}_0)$. Problem AE-2 is then the minimization of equation (5.4.12) over \underline{G}_0 .

5.5 The Necessary Conditions.

The matrix minimum principle yields necessary conditions which an optimum must satisfy. There are two conditions of importance.

(The third condition yields equation (5.4.6)).

From the necessary condition for the costate,

$$\underline{S}_{i,t}^* = \left. \frac{\partial H}{\partial \underline{\Sigma}_{i,t}} \right|_* \quad (5.5.1)$$

the propagation of $\underline{S}_{i,t}$ backward in time is derived.

$$\begin{aligned} \underline{S}_{i,t} = \pi_{i,t-1} & \left\{ \underline{Q} + \underline{G}_t^T \underline{R} \underline{G}_t \right. \\ & + \sum_{j=0}^L p_{ji} \frac{1}{\pi_{j,t}} \left[\underline{A}^T \underline{S}_{j,t+1} \underline{A} + \underline{G}_t^T \underline{B}_j^T \underline{S}_{j,t+1} \underline{B}_j \underline{G}_t \right. \\ & \left. \left. + \underline{A}^T \underline{S}_{j,t+1} \underline{B}_j \underline{G}_t + \underline{G}_t^T \underline{B}_j^T \underline{S}_{j,t+1} \underline{A} \right] \right\}. \quad (5.5.2) \end{aligned}$$

This equation is well-defined for any sequence $\{\underline{G}_t\}_{t=0}^{T-1}$ and $t > 0$.

The cost V of using this arbitrary sequence over the interval

$\{1, 2, \dots, T\}$ is given by

$$V(\underline{G}_t)_{t=0}^{T-1} = \text{tr} \left[\sum_{i=0}^L \underline{S}_{i,1} \underline{\Sigma}_{i,1} \right] \quad (5.5.3)$$

The total cost over the interval $\{0, 1, \dots, T\}$ using this sequence is

$$J_T = \text{tr} \left[\sum_{i=0}^L \underline{S}_{i,1} \underline{\Sigma}_{i,1} \right] + \text{tr} [(\underline{Q} + \underline{G}_0^T \underline{R} \underline{G}_0) \underline{\Sigma}_0] \quad (5.5.4)$$

$$= \text{tr} \left[\sum_{i=0}^L \left\{ (\underline{A} + \underline{B}_i \underline{G}_0) \underline{\Sigma}_0 (\underline{A} + \underline{B}_i \underline{G}_0)^T \underline{S}_{i,1} \right\} + \underline{\Sigma}_0 (\underline{Q} + \underline{G}_0^T \underline{R} \underline{G}_0) \right] \quad (5.5.5)$$

$$= \text{tr} \left[\underline{\Sigma}_0 \left\{ \underline{Q} + \underline{G}_0^T \underline{R} \underline{G}_0 + \sum_{i=0}^L (\underline{A} + \underline{B}_i \underline{G}_0)^T \underline{S}_{i,1} (\underline{A} + \underline{B}_i \underline{G}_0) \right\} \right] \quad (5.5.6)$$

Define

$$\underline{S}_0 \triangleq \sum_{i=0}^{L-1} (\underline{A} + \underline{B}_i \underline{G}_0)^T \underline{S}_{i,1} (\underline{A} + \underline{B}_i \underline{G}_0) + \underline{Q} + \underline{G}_0^T \underline{R} \underline{G}_0 \quad (5.5.7)$$

Then from equations (5.5.6) and (5.5.7)

$$J_T = \text{tr}[\underline{\Sigma}_0 \underline{S}_0] \quad (5.5.8)$$

Thus, the cost of a given sequence $(\underline{G}_t)_{t=0}^{T-1}$ of length T is

$$J_T = \text{tr}[\underline{\Sigma}_0 \underline{S}_0 (\underline{G}_0, \underline{G}_1, \dots, \underline{G}_{T-1})] \quad (5.5.9)$$

For future reference, define the matrix $\underline{S}'_{i,t}$ by

$$\underline{S}'_{i,t} \triangleq \frac{\underline{S}_{i,t}}{\pi_{i,t-1}} \quad (5.5.10)$$

and note that equation (5.5.2) becomes

$$\begin{aligned} \underline{S}_{i,t} = \underline{Q} + \underline{G}_t^T \underline{R} \underline{G}_t + \sum_{j=0}^{L-1} p_{ji} [\underline{A}^T \underline{S}_{j,t+1} \underline{A} + \underline{G}_t^T \underline{B}_j^T \underline{S}_{j,t+1} \underline{B}_j \underline{G}_t \\ + \underline{A}^T \underline{S}_{j,t+1} \underline{B}_j \underline{G}_t + \underline{G}_t^T \underline{B}_j^T \underline{S}_{j,t+1} \underline{A}] \end{aligned} \quad (5.5.11)$$

From the Hamiltonian minimization necessary condition

$$\left. \frac{\partial H}{\partial \underline{G}_t} \right|_* = 0 \quad (5.5.12)$$

the following relation between $\underline{\Sigma}_{i,t}$, $\underline{S}_{j,t+1}$, and \underline{G}_t is obtained.

$$\begin{aligned} \underline{0} = \underline{R} \underline{G}_t \sum_{i=0}^{L-1} \pi_{i,t-1} \underline{\Sigma}_{i,t} \\ + \sum_{j=0}^{L-1} \frac{1}{\pi_{j,t}} \left[[\underline{B}_j^T \underline{S}_{j,t+1} \underline{B}_j \underline{G}_t + \underline{B}_j^T \underline{S}_{j,t+1} \underline{A}] \sum_{i=0}^{L-1} p_{ji} \pi_{i,t-1} \underline{\Sigma}_{i,t} \right] \end{aligned} \quad (5.5.13)$$

Remark: At this point, a two-point boundary value problem has been defined with the constraint (5.5.13) relating equations (5.5.2) and (5.4.6). Equation (5.5.13) is not explicitly solvable for \underline{G}_t because $\underline{\Sigma}_{i,t}$ cannot be factored out of the sum over j ; thus, it cannot be used as a substitution rule in the other two equations. At this time, the solution for \underline{G}_t appears intractable. Thus, although necessary conditions for the existence of \underline{G}_t^* , the minimizing gain, have been established, they do not readily allow for the solution of \underline{G}_t^* , and certainly do not admit a closed-form expression.

5.6 Problem B: The Non-Switching Solution.

Although the methodology presented in Section 4 yields the necessary conditions for an optimum, these conditions are not analytically illuminating. In this section, a second optimization problem is formulated. An equivalent formulation was presented in [Birdwell & Athans, 40]. The solution will admit a closed form expression for \underline{u}_t . Although this solution is not the optimal solution for the first problem, in that this solution does not necessarily satisfy the necessary conditions for problem AE, it will be proved that the two solutions are equivalent in the sense that for the steady-state solutions, as defined in Section 7, either both solutions stabilize the system, or neither one stabilizes the system. Even better, it will be proved that the steady-state solutions to the problems are identical.

For the system (5.3.1), the objective is to minimize at each time t the weighted sum, with respect to $\underline{\pi}_{t-1}$, of the expected costs-to-go, given the control $\underline{u}_t = \underline{\phi}_t(\underline{x}_t)$ and $\underline{u}_\tau = \underline{\phi}_\tau^*(\underline{x}_\tau)$ for $\tau > t$, and given that the structure at time $t-1$ was $k(t-1) = i$, for each i .

Formally, let C be the expected cost-to-go, given \underline{x}_t , \underline{u}_t , and $k(t-1)$ at time t be defined as

$$C(\underline{x}_t, \underline{u}_t, k(t-1), t) \triangleq \underline{x}_t^T \underline{Q} \underline{x}_t + \underline{u}_t^T \underline{R} \underline{u}_t + E_{k(t)} [C^*(\underline{x}_{t+1}, k(t), t+1) | k(t-1)] \quad (5.6.1)$$

where $*$ denotes the optimum value, and \underline{u}_t^* is computed as

$$\underline{u}_t^* = \arg \min_{\underline{u}_t = \underline{\phi}_t(\underline{x}_t)} \langle \underline{\pi}_{t-1}, \underline{C}(t) \rangle \quad (5.6.2)$$

$$= \arg \min_{\underline{u}_t = \underline{\phi}_t(\underline{x}_t)} \underline{\pi}_{t-1}^T \underline{C}(t) \quad (5.6.3)$$

and

$$C^*(\underline{x}_t, k(t-1), t) = C(\underline{x}_t, \underline{u}_t^*, k(t-1), t) \quad (5.6.4)$$

where

$$\underline{C}(t) = \begin{bmatrix} C(\underline{x}_t, \underline{u}_t, k(t-1)=0, t) \\ \vdots \\ C(\underline{x}_t, \underline{u}_t, k(t-1)=L, t) \end{bmatrix} \quad (5.6.5)$$

and

$$\underline{C}(T) = \underline{C}^*(T) = \begin{bmatrix} \underline{x}_T^T \underline{Q} \underline{x}_T \\ \vdots \\ \underline{x}_T^T \underline{Q} \underline{x}_T \end{bmatrix} \quad (5.6.6)$$

Thus, the problem is

$$\begin{aligned} \min_{\underline{u}_t = \phi_t(\underline{x}_t)} & \sum_{i=0}^L \pi_{i,t-1} [\underline{x}_t^T \underline{Q} \underline{x}_t + \underline{u}_t^T \underline{R} \underline{u}_t \\ & + E[C^*(\underline{x}_{t+1}, k(t), t+1) | k(t-1)=i]] \end{aligned} \quad (5.6.7)$$

$$\begin{aligned} = \min_{\underline{u}_t = \phi_t(\underline{x}_t)} & \sum_{i=0}^L \pi_{i,t-1} \left[\underline{x}_t^T \underline{Q} \underline{x}_t + \underline{u}_t^T \underline{R} \underline{u}_t \right. \\ & \left. + \sum_{j=0}^L p_{ji} C^*(\underline{A} \underline{x}_t + \underline{B}_j \underline{u}_t, j, t+1) \right] \end{aligned} \quad (5.6.8)$$

From the formulation, \underline{u}_t is non-learning in that it depends only on π_{t-1} for its knowledge of the past. Let C^* be of the form

$$C^*(\underline{x}_t, k(t-1), t) = \underline{x}_t^T \underline{S}_{k,t}^* \underline{x}_t \quad (5.6.9)$$

Then for $t = T$,

$$\underline{S}_{k,T}^* = \underline{Q} \quad (5.6.10)$$

And equation (5.6.8) becomes

$$\min_{\underline{u}_t} \sum_{i=0}^L \pi_{i_{t-1}} \left[\underline{x}_t^T \underline{Q} \underline{x}_t + \underline{u}_t^T \underline{R} \underline{u}_t + \sum_{j=0}^L p_{ji} (\underline{A} \underline{x}_t + \underline{B}_j \underline{u}_t)^T \underline{S}'_{j,t+1} (\underline{A} \underline{x}_t + \underline{B}_j \underline{u}_t) \right] \quad (5.6.11)$$

At the minimum, differentiating (5.6.11) with respect to \underline{u}_t , we obtain

$$0 = \sum_{i=0}^L \pi_{i_{t-1}} \left[\underline{R} \underline{u}_t + \sum_{j=0}^L p_{ji} (\underline{B}_j^T \underline{S}'_{j,t+1} \underline{B}_j \underline{u}_t + \underline{B}_j^T \underline{S}'_{j,t+1} \underline{A} \underline{x}_t) \right] \quad (5.5.12)$$

Solving for \underline{u}_t ,

$$\underline{u}_t^* = - \left[\underline{R} + \sum_{j=0}^L \pi_{j_t} \underline{B}_j \underline{S}'_{j,t+1} \underline{B}_j \right]^{-1} \sum_{j=0}^L \pi_{j_t} \underline{B}_j \underline{S}'_{j,t+1} \underline{A} \underline{x}_t \quad (5.6.13)$$

and hence the gain matrix is given by

$$\underline{G}_t^* = - \left[\underline{R} + \sum_{j=0}^L \pi_{j_t} \underline{B}_j \underline{S}'_{j,t+1} \underline{B}_j \right]^{-1} \sum_{j=0}^L \pi_{j_t} \underline{B}_j \underline{S}'_{j,t+1} \underline{A} \quad (5.6.14)$$

where $\underline{u}_t^* = \underline{G}_t^* \underline{x}_t$

From (5.6.11) and (5.6.4),

$$\underline{x}_t^T \underline{S}'_{k,t} \underline{x}_t = \underline{x}_t^T \left[\underline{Q} + \underline{G}_t^{*T} \underline{R} \underline{G}_t^* + \sum_{j=0}^L p_{jk} (\underline{A} + \underline{B}_j \underline{G}_t^*)^T \underline{S}'_{j,t+1} (\underline{A} + \underline{B}_j \underline{G}_t^*) \right] \underline{x}_t \quad (5.6.15)$$

or, since (5.6.15) holds for all \underline{x}_t ,

$$\underline{S}'_{k,t} = \underline{Q} + \underline{G}_t^{*T} \underline{R} \underline{G}_t^* + \sum_{j=0}^L p_{jk} (\underline{A}^T \underline{S}'_{j,t+1} \underline{A} + \underline{A}^T \underline{S}'_{j,t+1} \underline{B}_j \underline{G}_t^* + \underline{G}_t^{*T} \underline{B}_j^T \underline{S}'_{j,t+1} \underline{A} + \underline{G}_t^{*T} \underline{B}_j \underline{S}'_{j,t+1} \underline{B}_j \underline{G}_t^*) \quad (5.6.16)$$

Thus, (5.6.16) proves by induction that equation (5.6.9) is valid.

Note that equations (5.6.16) and (5.5.11) are identical.

Therefore, the unconditional cost of \underline{G}_t^* , $t=0,1,\dots,T-1$, is, from

(5.5.9)

$$J_T = \text{tr}[\underline{\Sigma}_0 \underline{S}_0 (\underline{G}_0, \underline{G}_1, \dots, \underline{G}_{T-1})] \quad (5.6.17)$$

which in this case is simply

$$J_T = \underline{x}_0^T \underline{S}_0 (\underline{G}_0, \underline{G}_1, \dots, \underline{G}_{T-1}) \underline{x}_0 \quad (5.6.18)$$

The matrices \underline{G}_t^* are called the non-switching, or non-learning gains, and will hereafter be denoted \underline{G}_{ns_t} . The label \underline{G}_t^* will be reserved for

the solution to equation (5.5.13). The optimal value of the cost-to-go at time $t=0$ for this problem will be called the non-switching cost index, and is given by

$$J_{ns_T} = \sum_{i=0}^L \pi_{i_0} \underline{x}_{i_0}^T \underline{S}_{i,l} \underline{x}_{i_0} + \underline{x}_0^T (\underline{Q} + \underline{G}_{ns_0}^T \underline{R} \underline{G}_{ns_0}) \underline{x}_0 \quad (5.6.19)$$

$$= \underline{x}_0^T \left[\sum_{i=0}^L \pi_{i_0} (\underline{A} + \underline{B}_i \underline{G}_{ns_0})^T \underline{S}_{i,l} (\underline{A} + \underline{B}_i \underline{G}_{ns_0}) + \underline{Q} + \underline{G}_{ns_0}^T \underline{R} \underline{G}_{ns_0} \right] \underline{x}_0 \quad (5.6.20)$$

Note that if $\underline{G}_{ns_0} = \underline{G}_t^*$ for all time (i.e., if the solutions to the

optimal control gain problem and to the non-switching control problem

are the same, then $E_x [J_{ns_T}] = J_T$.

Summary: In this Section, the non-switching, or non-learning, gains have been derived. These gains are called non-switching or non-learning because they do not depend on the past trajectory of \underline{x}_t and \underline{u}_t , but only on the initial probability vector over I, $\underline{\pi}_0$. It was further shown that if the solutions to Problems AE and B were identical, then

$$E_{\underline{x}_0} [J_{ns_T}] = J_T \quad (5.6.21)$$

5.7 Stability and the Steady-State Solutions.

In this Section, the concept of stability for this class of systems will be precisely defined. From this, a natural concept of a steady-state solution to Problems AE and B will be given, and a very strong result relating the solutions to the two problems will be proved.

5.7.1 Stability and Cost-Stability.

For this class of systems, two definitions of stability will be tendered. The first is the usual definition of mean-square stability; the second definition, that of cost-stability, has a strong relation to the existence of solutions to the infinite time versions of Problems AE and B.

Definition 1: (Stability). \underline{G} is a constant stabilizing gain if and only if the resulting system given by equation (5.3.1) and repeated here

$$\underline{x}_{t+1} = \underline{A}\underline{x}_t + \underline{B}_k(t)\underline{u}_t \quad (5.3.1)$$

is mean-square stable:

$$E[\underline{x}_t \underline{x}_t^T] \rightarrow 0 \quad \text{as } t \rightarrow \infty. \quad (5.7.1)$$

Definition 2: (Cost-Stability). The system (5.3.1) is cost-stable if and only if the scalar random variable

$$\sum_{t=0}^{\infty} \underline{x}_t^T \underline{Q} \underline{x}_t + \underline{u}_t^T \underline{R} \underline{u}_t < \infty \quad (5.7.2)$$

with probability one.

5.7.2 Definition of the Infinite-Time Cost.

In this research, the infinite-time problem is defined as a minimization of

$$J = \lim_{T \rightarrow \infty} J_T \quad (5.7.3)$$

where J_T is the cost function for the corresponding finite-time problem. The sequences which solve these infinite-time versions of Problems A and B are $(\underline{G}_t^*)_{t=0}^{\infty}$ and $(\underline{G}_{ns_t})_{t=0}^{\infty}$, respectively, when a solution exists. A solution will exist if there exists a sequence of gains for which the limit in equation (5.7.3) exists. This definition of the infinite-time problem is chosen rather than the definition requiring a minimization of the average cost per unit time

$$J_1 = \lim_{T \rightarrow \infty} \frac{1}{T} J_T \quad (5.7.4)$$

because there is a direct correlation between the boundedness of J_T over all T for a constant sequence of gains \underline{G} and mean square stability of the system (5.3.1). It is necessary, however, to prove that the set of problems for which J_T is bounded for some sequence of gains is not vacuous. This fact is demonstrated by any of the convergent non-switching gain examples in Section 10.

As further demonstration of the validity of using equation (5.7.3), note that if $0 < J_1 < \infty$, then the cost per unit time has a non-zero steady-state value, which implies that the system (5.3.1) is not mean-square stable since

$$J_1 = \text{tr}[\underline{\Sigma}_{ss} (\underline{Q} + \underline{G}_{ss}^T \underline{R} \underline{G}_{ss})] \quad (5.7.5)$$

where $\underline{\Sigma}_{ss}$ and \underline{G}_{ss} are the steady-state values of $\underline{\Sigma}_t$ and \underline{G}_t , when they exist, and, since $\underline{Q} + \underline{G}_{ss}^T \underline{R} \underline{G}_{ss}$ is positive definite, $\underline{\Sigma}_{ss} \neq 0$.

5.7.3 Bounded Cost and Mean-Square Stability.

In choosing equation (5.7.3) as the basis for the definition of an infinite-time problem, a major requirement was that the existence of an infinite-time solution, namely of a sequence of gains which yields a finite cost in equation (5.7.3), imply mean-square stability. For the case where the sequence is constant, the following result is proved.

Theorem 1: A constant sequence of gains $(\underline{G})_{t=0}^{\infty}$ is mean-square stabilizing if and only if there exists a bound $B < \infty$ such that

$$J_T < B \quad \text{for all } T \quad (5.7.6)$$

Proof: See Appendix 5.1.

Remark: For a sequence $(\underline{G}_t)_{t=0}^{\infty}$, $J_t < B < \infty \forall T$ implies $(\underline{G}_t)_{t=0}^{\infty}$ is mean-square stabilizing, but $(\underline{G}_t)_{t=0}^{\infty}$ mean-square stabilizing does not imply J_T is bounded for all T .

Proof: See Appendix 5.2.

5.7.4 Cost-Stability.

As yet, the definition of cost-stability has not been utilized. In this Subsection, it will be shown that the system described by equation (5.3.1) is cost-stabilized by a sequence of gains $(\underline{G}_t)_{t=0}^{\infty}$ if and only if J is finite-valued for this sequence. One direction of this result is proved in the following theorem.

Theorem 2: Any sequence $(\underline{G}_t)_{t=0}^{\infty}$ for which $J < \infty$ cost-stabilizes (5.3.1) with probability 1.

Proof: See Appendix 5.3.

The other direction of this result is obvious: If a sequence $(\underline{G}_t)_{t=0}^{\infty}$ is cost-stabilizing with probability one, then the random cost, given by equation (5.7.2), is finite except on a set of structural trajectories of measure zero. (The appropriate measure on this set is given in the proof to Theorem 2.) Since the expected cost J is the integral of equation (5.7.2) with respect to the probability measure on the set of structural trajectories (see Appendix 5.3), then J is finite.

Thus, the cost-stability and the existence of an infinite-time solution are equivalent.

5.7.5 Equivalence of Problems AE and B.

The first major result of this Chapter will now be stated. This result establishes a strong equivalence between the solutions to Problems AE and B.

Theorem 3: A cost-stabilizing solution $(\underline{G}_{ns_t})_{t=0}^{\infty}$ exists if and only if there exists a cost-stabilizing solution $(\underline{G}_t^*)_{t=0}^{\infty}$, assuming $\pi_i > 0$ for all i and $\underline{\Sigma}_0 > 0$.

Proof : See Appendix 5.4.

Remark 1: This result provides a computationally feasible methodology for arriving at a sequence of gains $(\underline{G}_{ns_t})_{t=0}^{\infty}$ which cost-stabilize the original system (5.3.1) with probability 1, whenever such a sequence exists. The coupled matrix equations of Problem B (5.6.16) can be iterated backward in time. If the weighted sum with respect to the ergodic distribution $\underline{\pi}$ converges, then the resulting sequence of gains cost-stabilizes the system (5.3.1) with probability one.

5.7.6 The Steady-State Solution.

A steady-state solution to optimization Problems AE and B can exist only if there exists a steady-state probability distribution $\underline{\pi}$ over the set of possible configurations indexed by I such that

$$\underline{\pi} = \underline{P} \underline{\pi} \quad (5.7.7)$$

and

$$\lim_{t \rightarrow \infty} \underline{\pi}_t = \underline{\pi} \quad (5.7.8)$$

From equation (5.7.7), it is apparent that for $\underline{\pi}$ to exist, the matrix \underline{P} must have an eigenvalue at 1, and $\underline{\pi}$ must be in the subspace spanned by the eigenvectors of \underline{P} corresponding to that eigenvalue. The following lemma states precisely when $\underline{\pi}$ exists.

Lemma 1: $\underline{\pi}$ exists if and only if one of the following three conditions is satisfied for each diagonal element α_i of the Jordan normal form $\underline{\Lambda}$ of \underline{P} , where

$$\underline{P} = \underline{T} \underline{\Lambda} \underline{T}^{-1} \quad (5.7.9)$$

$$\underline{\Lambda} = \begin{bmatrix} \alpha_0 & \beta_0 & & & & \\ & \alpha_1 & \beta_1 & \underline{0} & & \\ & & \alpha_2 & & & \\ & & & \cdot & & \\ \underline{0} & & & & \cdot & \\ & & & & & \beta_{L-1} \\ & & & & & & \alpha_L \end{bmatrix} \quad \beta_i = 0 \text{ or } 1 \quad (5.7.10)$$

For each i,

- i) $|\alpha_i| < 1$
- ii) $\alpha_i = 1$
- iii) $|\alpha_i| = 1, \alpha_i \neq 1, (\underline{T}^{-1} \underline{\pi}_0)_i = 0$

Proof: Obvious.

5.7.6.1 Steady-State Solution to Problem AE.

Note that for Problem AE, initially, the gains $\underline{G}_0^*, \underline{G}_1^*, \dots$ will depend on $\underline{\Sigma}_0$, and near the final time, the gains $\dots \underline{G}_{T-2}^*, \underline{G}_{T-1}^*$ will depend on a time-varying $\underline{S}_{i,t}$. Thus, the steady-state solution for Problem AE is defined as the limiting solution to equations (5.4.6) (5.5.2) and (5.5.13) at time t , first as $T \rightarrow \infty$ and then as $t \rightarrow \infty$, if this limit exist. The steady-state values for \underline{B} , \underline{S}_i , and $\underline{\Sigma}_j$, when they exist, satisfy the following equations:

$$\underline{\Sigma}_j = \frac{1}{\pi_j} \sum_{i=0}^L P_{ji} \pi_i (\underline{A} + \underline{B}_j \underline{G}) \underline{\Sigma}_i (\underline{A} + \underline{B}_j \underline{G})^T \quad (5.7.11)$$

$$\underline{S}_i = \pi_i \left[\underline{Q} + \underline{G}^T \underline{R} \underline{G} + \sum_{j=0}^L P_{ji} \frac{1}{\pi_j} \left[\underline{A}^T \underline{S}_j \underline{A} + \underline{G}^T \underline{B}_j^T \underline{S}_j \underline{B}_j \underline{G} + \underline{A}^T \underline{S}_j \underline{B}_j \underline{G} + \underline{G}^T \underline{B}_j^T \underline{S}_j \underline{A} \right] \right] \quad (5.7.12)$$

$$0 = \underline{R} \underline{G} \sum_{i=0}^L \pi_i \underline{\Sigma}_i + \sum_{j=0}^L \frac{1}{\pi_j} \left[\underline{B}_j^T \underline{S}_j \underline{B}_j \underline{G} + \underline{B}_j^T \underline{S}_j \underline{A} \right] \sum_{i=0}^L P_{ji} \pi_i \underline{\Sigma}_i \quad (5.7.13)$$

which are the limit of equations (5.4.6), (5.5.2), and (5.5.13), given that the limiting solution $\underline{\Sigma}_{j,t}$ and \underline{G}_t^* exist, where $\underline{\pi}$ satisfies equations (5.7.7) and (5.7.8). The cost of this steady-state solution is

$$J = \lim_{T \rightarrow \infty} J_T \quad (5.7.14)$$

as in equation (5.7.3).

5.7.6.2 Steady-State Solution to Problem B.

The solution to Problem B depends on its past only through the probability distribution $\underline{\pi}(t)$ over the structure index set I. Therefore, to develop the steady-state solution, let the initial probability distribution $\underline{\pi}_0$ equal the steady-state value $\underline{\pi}$ from equations (5.7.7) and (5.7.8). Then the steady-state solution can be defined as the limit, when it exist, of the gain \underline{G}_{ns} calculated for the problem ending at time T, and of the solutions to the coupled Riccati-like equations (5.6.16), $\underline{S}_{i,0}$, as the final time approaches infinite. Let $\underline{G}_{ns_0}(T)$ and $\underline{S}'_{i,0}(T)$ be the solutions at time zero for Problem B with final time T. Then

$$\underline{G}_{ns} = \lim_{T \rightarrow \infty} \underline{G}_{ns_0}(T) \quad (5.7.15)$$

$$\underline{S}'_i = \lim_{T \rightarrow \infty} \underline{S}'_{i,0}(T) \quad , \quad i \in I \quad (5.7.16)$$

when the limits exist. The steady-state solution is said to exist whenever the limits of equation (5.7.16) exist. If these limits exist, then \underline{G}_{ns} and \underline{S}'_i must satisfy, from equations (5.6.14) and (5.6.16).

$$\underline{G}_{ns} = - \left[\underline{R} + \sum_{j=0}^L \pi_j \frac{\underline{B}_j^T}{\underline{B}_j} \underline{S}'_j \frac{\underline{B}_j}{\underline{B}_j} \right]^{-1} \sum_{j=0}^L \pi_j \frac{\underline{B}_j^T}{\underline{B}_j} \underline{S}'_j \underline{A} \quad (5.7.17)$$

$$\begin{aligned} \underline{S}'_k &= \underline{Q} + \underline{G}_{ns}^T \underline{R} \underline{G}_{ns} \\ &+ \sum_{j=0}^L p_{jk} \left(\underline{A}^T \underline{S}'_j \underline{A} + \underline{A}^T \underline{S}'_j \underline{B}_j \underline{G}_{ns} + \underline{G}_{ns}^T \underline{B}_j^T \underline{S}'_j \underline{A} \right. \\ &\left. + \underline{G}_{ns}^T \underline{B}_j^T \underline{S}'_j \underline{B}_j \underline{G}_{ns} \right) \end{aligned} \quad (5.7.18)$$

The cost of this steady-state solution, given \underline{x} , is, when the limit exists

$$J_{ns} = \lim_{T \rightarrow \infty} J_{ns_T} = \underline{x}^T \sum_{i=0}^{T-1} \pi_i S_i \underline{x} \quad (5.7.19)$$

5.7.7 The Possibility of Limit Cycles.

The discussions in the last Section do not rule out the possibility of limit cycles in an infinite-time solution. In Problem B, the expected cost is directly computable from a set of coupled Riccati-like equations (5.6.16), as is the non-switching gain (5.6.14). If these coupled matrix equations converge whenever the solution is bounded, then the non-switching gain is always directly computable when it exists. Boundedness implies convergence of the expected cost (Lemma 2); however, the possibility of the existence of a limit cycle in the solution to equation (5.6.16) is not ruled out. It is conjectured, but not proved, that such a limit cycle cannot exist.

Lemma 2: If the expected cost J_T^* for Problem A is bounded, then it converges.

Proof: See Appendix 5.5.

Since $E_x [J_{ns_T}] = J_T^*$, J_{ns_T} also converges.

5.8 Equality of \underline{G}_{ns} and \underline{G}^* .

In this Section it will be shown that when a steady-state \underline{G}_{ns} and \underline{G}^* exist, with finite cost J_{ns}^* and J^* , the gains are equal. This result is extremely important in that it yields a method of calculating the steady-state solution to a two-point boundary value problem as the limiting solution to an equivalent (in the steady-state) single boundary value problem. It is taken as a working hypothesis in this Section that both problems have a steady-state solution and that the ergodic distributions of $\underline{\pi}$ and $\underline{\Sigma}_i$, for all i , exist. Then the steady-state cost of the optimal problem is

$$J_{ss}^* = \text{tr}[\underline{\Sigma}_0 (\underline{Q} + \underline{G}_0^* \underline{R} \underline{G}_0^*)] + \sum_{i=0}^L \text{tr}[\underline{\Sigma}_i^* \underline{S}_i^*] \quad (5.8.1)$$

For any constant gain \underline{G} for which the limits exist, the value would be

$$J_{ss}(\underline{G}) = \text{tr}[\underline{\Sigma}_0 (\underline{Q} + \underline{G}^T \underline{R} \underline{G})] + \sum_{i=0}^L \text{tr}[\underline{\Sigma}_i(\underline{G}) \underline{S}_i(\underline{G})] \quad (5.8.2)$$

$$= \text{tr}[\underline{\Sigma}_0 (\underline{Q} + \underline{G}^T \underline{R} \underline{G})] + \sum_{i=0}^L \text{tr}[(\underline{A} + \underline{B}_i \underline{G}) \underline{\Sigma}_0 (\underline{A} + \underline{B}_i \underline{G})^T \underline{S}_i(\underline{G})] \quad (5.8.3)$$

$$= \text{tr} \left[\underline{\Sigma}_0 \left\{ \underline{Q} + \underline{G}^T \underline{R} \underline{G} + \sum_{i=0}^L (\underline{A} + \underline{B}_i \underline{G})^T \underline{S}_i(\underline{G}) (\underline{A} + \underline{B}_i \underline{G}) \right\} \right] \quad (5.8.4)$$

Similarly, equation (5.8.1) becomes

$$J_{ss}^* = \text{tr} \left[\underline{\Sigma}_0 \left\{ \underline{Q} + \underline{G}_0^{*T} \underline{R} \underline{G}_0^* + \sum_{i=0}^L (\underline{A} + \underline{B}_i \underline{G}_0^*)^T \underline{S}_i^* (\underline{A} + \underline{B}_i \underline{G}_0^*) \right\} \right] \quad (5.8.5)$$

For the non-switching, or non-learning problem, the steady-state cost for any \underline{G} for which the $\underline{S}_{i,t}$ converge is, given \underline{x}_0 ,

$$J_{ns_{ss}}(\underline{G}) = \underline{x}_0^T (\underline{Q} + \underline{G}_0^T \underline{R} \underline{G}) \underline{x}_0 + E \left[\sum_{i=0}^L \pi_i \underline{x}_1^T \underline{S}_i(\underline{G}) \underline{x}_1 \right] \quad (5.8.6)$$

$$= \underline{x}_0^T (\underline{Q} + \underline{G}^T \underline{R} \underline{G}) \underline{x}_0 + \underline{x}_0^T \sum_{i=0}^L \pi_i (\underline{A} + \underline{B}_i \underline{G})^T \underline{S}_i(\underline{G}) (\underline{A} + \underline{B}_i \underline{G}) \underline{x}_0 \quad (5.8.7)$$

Taking expectations with respect to \underline{x}_0 ,

$$E \left[J_{ns_{ss}}(\underline{G}) \right] = \text{tr} [\underline{\Sigma}_0 (\underline{Q} + \underline{G}^T \underline{R} \underline{G})] + \sum_{i=0}^L \text{tr} [\underline{\Sigma}_0 (\underline{A} + \underline{B}_i \underline{G})^T \underline{S}_i(\underline{G}) (\underline{A} + \underline{B}_i \underline{G})] \quad (5.8.8)$$

or,

$$E \left[J_{ns_{ss}}(\underline{G}) \right] = J_{ss}(\underline{G}) \quad (5.8.9)$$

Thus, the costs are equivalent for any \underline{G} for which the equations converge.

By Lemma 3, if the non-switching expected cost is bounded for a single \underline{G} , then the equations converge; i.e., there can be no limit cycle.

Lemma 3: For a given gain \underline{G} , if the expected cost $J_T(\underline{G})$ is bounded then it converges.

Proof: See Appendix 5.6.

Thus, either equation (5.8.9) holds, or both costs are infinite. Therefore, if the cost is finite for any single \underline{G} , then there exists a \underline{G}_{opt} which minimizes both costs. Furthermore, given that $\underline{G}_{ns_t}(T)$ converges, $\underline{G}_{ns_t}(T) \rightarrow \underline{G}_{opt}$ as $T \rightarrow \infty$. This result with an extension is stated in Theorem 4.

Theorem 4: Assume the values $\underline{G}_t^*(T)$, $\underline{G}_{ns_t}(T)$, $\underline{S}_{i,t}(T)$, $\underline{S}'_{i,t}(T)$, and

$\underline{\Sigma}_{i,t}$ converge. Then

A) $\underline{G}_{ns_t}(T) \rightarrow \underline{G}_{opt}$ as $T \rightarrow \infty$, which minimizes equation (5.8.9).

B) $\underline{G}_{ns} = \underline{G}^*$, where \underline{G}_{ns} is the steady-state value of $\underline{G}_{ns_t}(T)$,

and \underline{G}^* is the steady-state value of $\underline{G}_t^*(T)$:

$$\lim_{t \rightarrow \infty} \lim_{T \rightarrow \infty} \underline{G}_t^*(T) = \underline{G}^* \quad (5.8.10)$$

Proof: See Appendix 5.7.

Discussion: The result of Theorem 4 B) gives a direct computational procedure for calculating the optimal steady-state gain \underline{G}^* as the limiting gain \underline{G}_{ns} . There are, however, still some open questions concerning the existence of limit cycles in the calculation of \underline{G}_{ns} . Theorem 3, however, guarantees cost-stability using $(\underline{G}_{ns_t})_{t=0}^{\infty}$ if a cost-stabilizing sequence of gains exists.

5.9 Robustness.

The original problem (Problem A) can be formulated in such a way that the sequence $(\underline{G}_{ns_t})_{t=0}^{\infty}$ will cost-stabilize a set of linear systems with different actuator structures individually whenever such a stabilizing or robust gain exists.

Definition 3: A gain \underline{G} is robust if

$$\underline{x}_{t+1} = (\underline{A} + \underline{B}_k \underline{G}) \underline{x}_t \quad (5.9.1)$$

is stable for all k . This is the same as requiring the matrix $(\underline{A} + \underline{B}_k \underline{G})$ to have eigenvalues inside the unit circle for all k .

Corollary 1: For the set of $L+1$ systems

$$\underline{x}_{t+1} = \underline{A} \underline{x}_t + \underline{B}_k \underline{u}_t \quad (5.9.2)$$

with

$$\underline{P} = \underline{I} \quad (5.9.3)$$

$$\pi_j = \frac{1}{L+1} \quad (5.9.4)$$

if a robust gain exists, then $(\underline{G}_{ns_t})_{t=0}^{\infty}$ is a stabilizing sequence for (5.9.1) for each k , and if the gains $\underline{G}_{ns_t}(T)$ converge, then \underline{G}_{ns} is a robust gain.

Proof: For the expected cost to be finite, for any \underline{G} , \underline{G} must be robust, since each structure is equally likely and no structural changes can occur. Therefore, if a robust \underline{G} exists, then certainly $(\underline{G}_t^*)_{t=0}^{\infty}$ will be stabilizing, and by Theorem 3, so will $(\underline{G}_{ns_t})_{t=0}^{\infty}$. Also, if

$\underline{G}_{ns_t}(T)$ converges as $T \rightarrow \infty$, the \underline{G}_{ns} will be robust since it will have

finite cost $J(\underline{G}_{ns})$, which implies stability, in this case, for all $k \in I$.

Q.E.D.

Discussion: With Corollary 1, a specific existence problem for robust linear gains is solved. Existence of a robust gain is made equivalent to the existence of a finite cost infinite-time solution to Problem B, which is readily computable from equations (5.6.14) and (5.6.16).

5.10 Examples.

In this section, two examples are presented to illustrate the non-switching gain computational methodology. Example 5.1 is analogous to Example 3.1 of Chapter 3; it demonstrates the effect of component reliability on system stabilizability with a non-switching gain control law. The first case of Example 5.1 is not convergent; the second case is convergent. The only difference between the two cases is the reliability of the actuators. Case i) corresponds to Case ii) of Example 3.1; Case ii) corresponds to Case iii) of Example 3.1. Neither case results in a robust control law, but robustness is not possible because the system is uncontrollable in structural state 3. As an aside, it is interesting that the "optimal" non-switching gain in Case i) ignores state x_2 ; the system is decoupled in that there is no interaction between x_1 and x_2 . Since state x_2 has stable dynamics, and the dynamics of state x_1 are unstable, the entire control effect is concentrated on state x_1 .

The computer routines which are used in the calculation of the non-switching gain solution are listed in the Appendix. The primary subroutine is AIM; it calls WEIGHT. Any other routines which are used are from the standard ESL subroutine library.

Example 5.1:

$$\underline{A} = \begin{bmatrix} 2.71828 & 0.0 \\ 0.0 & .36788 \end{bmatrix}$$

$$\underline{B}_0 = \begin{bmatrix} 1.71828 & 1.71828 \\ -.63212 & .63212 \end{bmatrix} \quad \underline{B}_1 = \begin{bmatrix} 0.0 & 1.71828 \\ 0.0 & .63212 \end{bmatrix}$$

$$\underline{B}_2 = \begin{bmatrix} 1.71828 & 0.0 \\ -.63212 & 0.0 \end{bmatrix} \quad \underline{B}_3 = \begin{bmatrix} 0.0 & 0.0 \\ 0.0 & 0.0 \end{bmatrix}$$

$$\underline{Q} = \begin{bmatrix} 14. & 8. \\ 8. & 6. \end{bmatrix} \quad \underline{R} = \begin{bmatrix} 1.0 & 0.0 \\ 0.0 & 1.0 \end{bmatrix}$$

$$\underline{P} = \begin{bmatrix} 1-2p_f+p_f^2 & (1-p_f)p_r & (1-p_f)p_r & p_r^2 \\ p_f-p_f^2 & 1-p_f-p_r+p_f p_r & p_r p_f & p_r(1-p_r) \\ p_f-p_f^2 & p_r p_f & 1-p_f-p_r+p_f p_r & p_r(1-p_r) \\ p_f^2 & (1-p_r)p_f & (1-p_r)p_f & 1-2p_r+p_r^2 \end{bmatrix}$$

The system is

$$\underline{x}_{t+1} = \underline{A}\underline{x}_t + \underline{B}_{k(t)}\underline{u}_t \quad \underline{x}_t = [x_{1,t} \quad x_{2,t}]^T$$

$$k(t) \in \{0,1,2,3\}$$

The cost to be minimized is

$$J = E \left[\sum_{t=0}^{\infty} \underline{x}_t^T \underline{Q} \underline{x}_t + \underline{u}_t^T \underline{R} \underline{u}_t \mid \underline{\pi} \right]$$

Example 5.1, Case i)

$$p_f = .1, \quad p_r = .9$$

$$\underline{\pi} = \begin{bmatrix} .81 \\ .09 \\ .09 \\ .01 \end{bmatrix} = \begin{bmatrix} \pi_0 \\ \pi_1 \\ \pi_2 \\ \pi_3 \end{bmatrix}$$

Non-Convergent; but gain converges at

$$\underline{G}_{ns} = \begin{bmatrix} -1.246 & 0.0 \\ -1.039 & 0.0 \end{bmatrix}$$

Stability:

| Configuration | Stable |
|-------------------------|--------|
| 0 (\underline{B}_0) | no |
| 1 (\underline{B}_1) | yes |
| 2 (\underline{B}_2) | yes |
| 3 (\underline{B}_3) | no |

Interpretation: The coupled Riccati equations are unbounded. Note that since state x_2 has stable dynamics, the convergent non-switching gain \underline{G}_{ns} concentrates on stabilizing x_1 , which is open-loop unstable. From the above stability table, the control law

$$\underline{u}_t = \underline{G}_{ns} \underline{x}_t$$

stabilizes only configuration states 1 and 2; since the configuration has a high probability of being in state 0 (unstable), the cost diverges.

Example 5.1, Case ii)

$$p_f = .01, \quad p_r = .98$$

$$\underline{\pi} = \begin{bmatrix} .9799 \\ .009999 \\ .009999 \\ .0001020 \end{bmatrix} = \begin{bmatrix} \pi_0 \\ \pi_1 \\ \pi_2 \\ \pi_3 \end{bmatrix}$$

135

Convergent Coupled Riccati Equations.

$$\underline{G}_{ns} = \begin{bmatrix} -.7563 & .1266 \\ -.8070 & -.1784 \end{bmatrix}$$

Stability:

| Configuration | Stable |
|-------------------------|--------|
| 0 (\underline{B}_0) | yes |
| 1 (\underline{B}_1) | no |
| 2 (\underline{B}_2) | no |
| 3 (\underline{B}_3) | no |

Interpretation: With more reliable actuators, the non-switching gain expends less force on the stabilization of configuration states 1 and 2 (unstable); since configuration state 0 is stabilized, and the system has a (relatively) higher probability of being in configuration state 0 than in Case i), the non-switching coupled Riccati equations converge, resulting in a finite cost.

Example 5.2 uses the same system dynamics as in Example 5.1; however, only structures 0,1 and 2 (the controllable structures) are considered. The configuration dynamics are modeled as being in any structural state with equal probability of occurrence initially and remaining in that state forever; this model is illustrated graphically in Figure 5.1.

The state dynamics are

$$\underline{x}_{t+1} = \underline{A}\underline{x}_t + \underline{B}_{k(t)}\underline{u}_t \quad \underline{x}_t = [x_{1,t} \quad x_{2,t}]^T$$

$$k(t) \in \{0,1,2\}$$

The cost to be minimized is

$$J = E \left[\sum_{t=0}^{\infty} \underline{x}_t^T \underline{Q} \underline{x}_t + \underline{u}_t^T \underline{R} \underline{u}_t \mid \pi \right]$$

The non-switching methodology yields a robust control law of the form

$$\underline{u}_t = \underline{G}_{ns} \underline{x}_t$$

76265AW030

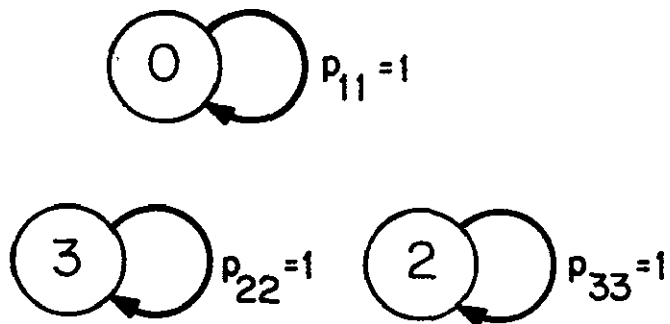

Figure 5.1: Markov transition probabilities for Example 5.2.

Example 5.2:

$$\underline{A} = \begin{bmatrix} 2.71828 & 0.0 \\ 0.0 & .3679 \end{bmatrix}$$

$$\underline{B}_0 = \begin{bmatrix} 1.71828 & 1.71828 \\ -.63212 & .63212 \end{bmatrix}$$

$$\underline{B}_1 = \begin{bmatrix} 0.0 & 1.71828 \\ 0.0 & .63212 \end{bmatrix}$$

$$\underline{B}_2 = \begin{bmatrix} 1.71828 & 0.0 \\ -.63212 & 0.0 \end{bmatrix}$$

$$\underline{P} = \begin{bmatrix} 1. & 0. & 0. \\ 0. & 1. & 0. \\ 0. & 0. & 1. \end{bmatrix}$$

Convergent:

$$\underline{G}_{ns} = \begin{bmatrix} -1.089 & -.008413 \\ -1.028 & -.01444 \end{bmatrix}$$

$$\sum_{i=0}^2 \pi_i S_i = \begin{bmatrix} 112.8 & 8.992 \\ 8.992 & 6.835 \end{bmatrix} \triangleq \underline{C}$$

Stability:

| Configuration | Stable |
|-------------------------|--------|
| 0 (\underline{B}_0) | yes |
| 1 (\underline{B}_1) | yes |
| 2 (\underline{B}_2) | yes |

Robust: yes

Riccati Solution:

$$\underline{S}_0 = \begin{bmatrix} 109.8 & 9.030 \\ 9.030 & 6.821 \end{bmatrix}$$

$$\underline{S}_1 = \begin{bmatrix} 114.3 & 6.285 \\ 6.285 & 6.836 \end{bmatrix}$$

$$\underline{S}_2 = \begin{bmatrix} 114.4 & 11.66 \\ 11.66 & 6.849 \end{bmatrix}$$

The non-switching solution converges for the system in Example 5.2, and the three resulting configurations are stabilized. Therefore \underline{G}_{ns} is a robust gain. Had the solution not converged, by Corollary 1 of Section 9, no robust gain would exist.

The apriori expected cost (before the configuration state is known) is, given \underline{x}

$$J = \underline{x}^T \underline{C} \underline{x}$$

5.11 Summary.

In this Chapter, an optimization problem was defined on linear systems with variable actuator configurations and quadratic cost criteria. The objective of this approach was to compute apriori a sequence of gains to be used in linear feedback control which do not depend on any on-line information about the process. These gains were to both stabilize the overall system, accounting for the various possible structures and minimize the expected value of the quadratic cost criterion, where the expectation is taken over the possible sequences of actuator configurations. This solution depends on both the performance, and on the reliability of the various structures, as represented by the Markov transition probabilities between structures.

The matrix minimum principle [Athans,41] was used to establish the necessary conditions for optimality of a solution to an equivalent deterministic problem to that described above, known as Problem AE in the Chapter. These conditions unfortunately do not yield an analytic solution for the gain sequence, but instead yielded an ill-posed two-point boundary value problem which must be solved numerically (Section 5). Therefore, a second problem (Problem B) was formulated which was solvable analytically using dynamic programming (Section 6). This solution has identical cost-stabilizing properties to the solution of Problem AE, but has the advantage of being directly computable.

The steady-state solutions to the infinite-time versions of both problems were defined, when they exist, and it was proved that, in addition to the equivalent stabilizing property of the two solutions, the steady-state values are identical, and this value is the same as the

optimal constant gain which minimizes the expected cost over the infinite time interval.

In addition, the general robustness question of when one gain can stabilize a set of linear systems with different actuator configurations was formulated in the context of Problem A and was solved by Problem B. Thus, a test for when a robust gain exists can be performed by iterating a set of coupled matrix Riccati-like equations and testing for convergence of a function of the solutions. If, in addition, the individual solutions converge, then the robust gain which minimizes the expected quadratic cost index can be calculated directly. It was noted that the extension to systems with variable dynamics (variations in \underline{A}), as well as variable actuator structure, is trivial as long as the dimension of the state is constant.

The major applications of this work are in the calculation of a robust gain for a set of linear systems and in the calculations of stabilizing gains for systems with variable structure, such as occurs in failure, repair, or reconfiguration. A second application will be covered in the next Chapter and involves using these calculations in a computer-aided design procedure for the determination of the relative effectiveness of various redundant component configurations.

CHAPTER 6

COMPUTER-AIDED DESIGN

6.1 Introduction.

In this Chapter, two specific applications of the non-switching gain methodology to computer-aided design are presented. Example 6.1 illustrates the usefulness of the non-switching gain methodology in the selection of an actuator design. Five possible designs are analyzed using the non-switching gain calculations as a basis for ranking the designs with respect to their expected performance. Example 6.2 compares two actuators, of which one is more reliable, but less effective (in that it incurs a greater cost for the same action) than the other. Three cases with various actuator reliabilities are presented as a study of the trade-off between actuator reliability and effectiveness.

These two examples are intended to demonstrate the usefulness of the non-switching gain methodology in design studies. No general methodology for computer-aided design using the results presented in this report is presented. Instead, tools are presented which can be used in the computer-aided design of system configurations.

6.2 The Design Decision.

A designer often has many means of achieving a desired goal; however, no unified methodology exists which can be used to choose a given design that is "better" than any other. At best, a set of tools can be developed which are applicable to specific situations and classes

of systems. Of these tools, all that are presently available evaluate a system either on the basis of performance or on the basis of reliability. The methodologies described in this report optimize a performance index which depends on both system reliability and system performance. Therefore, it is logical to apply these methodologies to the computer-aided design of system configurations.

Example 6.1 is an aid in the design of a linear system for which the state dynamics are fixed, but the actuator configuration is to be at most two actuators (one level of either component or functional redundancy) chosen from two types of actuators. The system in Example 6.1 is defined by

$$\underline{x}_{t+1} = \underline{A}\underline{x}_t + \underline{B}_{k(t)} \underline{u}_t \quad (6.2.1)$$

$$k(t) \in I \quad (6.2.2)$$

where $\underline{x}_t = [x_{1,t}, x_{2,t}, x_{3,t}]^T$. In Cases i) and ii), $I = \{0,1\}$; in Cases iii), iv), v), $I = \{0,1,2,3\}$. The cost to be minimized is

$$J_T = E \left[\sum_{t=0}^{\infty} \underline{x}_t^T \underline{Q} \underline{x}_t + \underline{u}_t^T \underline{R} \underline{u}_t \mid \underline{\pi} \right] \quad (6.2.3)$$

The cost of each actuator (labeled \underline{b}_0 and \underline{b}_1) is to be the quadratic cost incurred by the control input to that actuator. These costs are represented by the quadratic weights r_0 and r_1 , respectively, and are equal in Example 6.1. The actuators act on different states of the system; actuator \underline{b}_0 applies the control force to state x_2 , while \underline{b}_1 applies the control force to state x_3 . Each actuator can fail to an actuator with zero gain, $\underline{0}$. Repair constitutes replacement of the failed component with a new actuator, identical to the original actuator. The repair action is modeled using a Markov transition probability p_r , the probability of repair per unit of time. The actuators

have identical probabilities of failure and repair per unit time, p_f and p_r , respectively. The five possible actuator configurations are, in the order in which they are presented in Example 6.1,

$$\underline{B}^1 = \left[\underline{b}_0 \right] \quad (6.2.4)$$

$$\underline{B}^2 = \left[\underline{b}_1 \right] \quad (6.2.5)$$

$$\underline{B}^3 = \left[\underline{b}_0 \mid \underline{b}_0 \right] \quad (6.2.6)$$

$$\underline{B}^4 = \left[\underline{b}_1 \mid \underline{b}_1 \right] \quad (6.2.7)$$

$$\underline{B}^5 = \left[\underline{b}_0 \mid \underline{b}_1 \right] \quad (6.2.8)$$

Configurations \underline{B}^1 and \underline{B}^2 have two-state configuration dynamics directly defined by the failure and repair probabilities per unit time. Configurations \underline{B}^3 , \underline{B}^4 and \underline{B}^5 have four-state configuration dynamics represented graphically by Figure 3.2 of Chapter 3, Section 5. It is not immediately obvious from the configurations and the state dynamics which configuration is optimal. When a non-switching gain control is used, the expected steady-state cost, given by equation (5.7.3), is a measure of the expected performance of each configuration, and can be used to rank the five configurations in order of system effectiveness. System effectiveness is a measure of the expected performance of a system, taking into account all postulated modes of operation. Therefore, in Example 6.1, the non-switching gain and expected cost is computed for each of the five design configurations.

Example 6.1:

$$\underline{A} = \begin{bmatrix} 2.0000 & .5000 & .5000 \\ 0.0 & 0.0 & 1.000 \\ 0.0 & -1.000 & 0.0 \end{bmatrix}$$

$$\underline{Q} = \begin{bmatrix} 1.0 & 0.0 & 0.0 \\ 0.0 & 1.0 & 0.0 \\ 0.0 & 0.0 & 1.0 \end{bmatrix}$$

$$\underline{b}_0 = \begin{bmatrix} 0.0 \\ 0.0 \\ 1.0 \end{bmatrix}, \quad r_0 = 1.0$$

$$\underline{b}_1 = \begin{bmatrix} 0.0 \\ 1.0 \\ 0.0 \end{bmatrix}, \quad r_1 = 1.0$$

$$\underline{0} = \begin{bmatrix} 0.0 \\ 0.0 \\ 0.0 \end{bmatrix}$$

$$p_{f_0} = p_{f_1} = p_f = .01$$

$$p_{r_0} = p_{r_1} = p_r = .98$$

$$\underline{b}_i = \begin{matrix} p_{f_i} \\ p_{r_i} \end{matrix} \underline{0}$$

Example 6.1 Case i)

$$\underline{B}_0 = \begin{bmatrix} \underline{b}_0 \end{bmatrix} = \text{conf. } 0 \quad (\text{conf. } \underline{\Delta} \text{ configuration})$$

$$\underline{B}_1 = \underline{0} = \text{conf. } 1 \quad \underline{R} = \begin{bmatrix} r_0 \end{bmatrix} = \begin{bmatrix} 1.0 \end{bmatrix}$$

$$\underline{P} = \begin{bmatrix} 1-p_f & p_r \\ p_f & 1-p_r \end{bmatrix} = \begin{bmatrix} .99 & .98 \\ .01 & .02 \end{bmatrix}$$

$$\underline{\Pi} = \begin{bmatrix} .9899 \\ .01010 \end{bmatrix} = \begin{bmatrix} \pi_0 \\ \pi_1 \end{bmatrix}$$

Convergent Coupled Riccati Equations:

$$\underline{G}_{ns} = \begin{bmatrix} -4.863 & -.2582 & -1.733 \end{bmatrix}$$

$$\underline{S}'_0 = \begin{bmatrix} 182.5 & 37.06 & 57.93 \\ 37.06 & 9.943 & 12.32 \\ 57.93 & 12.32 & 22.81 \end{bmatrix}$$

$$\underline{S}'_1 = \begin{bmatrix} 188.6 & 37.39 & 60.09 \\ 37.39 & 9.961 & 12.44 \\ 60.09 & 12.44 & 23.58 \end{bmatrix}$$

$$\sum_{i=0}^1 \pi_i \underline{S}'_i = \begin{bmatrix} 182.6 & 37.07 & 57.95 \\ 37.07 & 9.943 & 12.33 \\ 57.95 & 12.33 & 22.82 \end{bmatrix} \stackrel{\Delta}{=} \underline{C}$$

$$\text{Expected cost} = \underline{x}^T \underline{C} \underline{x}$$

Stability:

| Configuration | Stable |
|-------------------------|--------|
| 0 (\underline{B}_0) | yes |
| 1 (\underline{B}_1) | no |

Interpretation: The steady-state non-switching gain exists; it stabilizes configuration 0 (\underline{B}_0), but does not stabilize configuration 1 (\underline{B}_1). Since the probability of being in configuration 0 (stable) (π_0) is much greater than the probability of being in configuration 1 (unstable) (π_1), the system configuration is stabilized using the non-switching gain \underline{G}_{ns} in the control law

$$\underline{u}_t = \underline{G}_{ns} \underline{x}_t$$

Example 6.1 Case ii)

$$\underline{B}_0 = \begin{bmatrix} \underline{b}_1 \end{bmatrix} = \text{conf. } 0$$

$$\underline{B}_1 = \underline{0} = \text{conf. } 1 \quad \underline{R} = \begin{bmatrix} r_0 \end{bmatrix} = \begin{bmatrix} 1.0 \end{bmatrix}$$

$$\underline{P} = \begin{bmatrix} 1-p_f & p_r \\ p_f & 1-p_r \end{bmatrix} = \begin{bmatrix} .99 & .98 \\ .01 & .02 \end{bmatrix}$$

$$\underline{\pi} = \begin{bmatrix} .9899 \\ .01010 \end{bmatrix} = \begin{bmatrix} \pi_0 \\ \pi_1 \end{bmatrix}$$

Convergent Coupled Riccati Equations:

$$\underline{G}_{ns} = \begin{bmatrix} -12.59 & -1.484 & -4.097 \end{bmatrix}$$

$$\underline{S}'_0 = \begin{bmatrix} 1035. & 125.0 & 271.4 \\ 125.0 & 18.84 & 33.04 \\ 271.4 & 33.04 & 73.80 \end{bmatrix}$$

$$\underline{S}'_1 = \begin{bmatrix} 1069. & 129.0 & 282.6 \\ 129.0 & 19.31 & 34.34 \\ 282.6 & 34.34 & 77.43 \end{bmatrix}$$

$$\sum_{i=0}^1 \pi_i \underline{S}'_i = \begin{bmatrix} 1035. & 125.0 & 271.6 \\ 125.0 & 18.85 & 33.05 \\ 271.6 & 33.05 & 73.83 \end{bmatrix} \triangleq \underline{C}$$

$$\text{Expected cost} = \underline{x}^T \underline{C} \underline{x}$$

Stability:

| Configuration | Stable |
|---------------|--------|
| 0 | yes |
| 1 | no |

Interpretation: The steady-state non-switching gain exists; it stabilizes configuration 0 (\underline{B}_0), but does not stabilize configuration 1 (\underline{B}_1). Since the probability of being in configuration 0 (stable) (π_0) is much greater than the probability of being in configuration 1 (unstable) (π_1), the system configuration is stabilized using the non-switching gain \underline{G}_{ns} in the control law

$$\underline{u}_t = \underline{G}_{ns} \underline{x}_t$$

Example 6.1 Case iii)

$$\underline{B}_0 = \left[\underline{b}_0 \mid \underline{b}_0 \right] = \text{conf. 0} \quad \underline{B}_2 = \left[\underline{b}_0 \mid \underline{0} \right] = \text{conf. 2}$$

$$\underline{B}_1 = \left[\underline{0} \mid \underline{b}_0 \right] = \text{conf. 1} \quad \underline{B}_3 = \left[\underline{0} \mid \underline{0} \right] = \text{conf. 3}$$

$$\underline{R} = \begin{bmatrix} r_0 & 0.0 \\ 0.0 & r_0 \end{bmatrix} = \begin{bmatrix} 1.0 & 0.0 \\ 0.0 & 1.0 \end{bmatrix}$$

$$\underline{P} = \begin{bmatrix} 1-2p_f+p_f^2 & p_r(1-p_f) & p_r(1-p_f) & p_r^2 \\ p_f(1-p_f) & 1-p_r-p_f+p_r p_f & p_r p_f & p_r(1-p_r) \\ p_f(1-p_f) & p_r p_f & 1-p_r-p_f+p_r p_f & p_r(1-p_r) \\ p_f^2 & p_f(1-p_r) & p_f(1-p_r) & 1-2p_r+p_r^2 \end{bmatrix}$$

$$= \begin{bmatrix} .9801 & .9702 & .9702 & .9604 \\ .0099 & .0198 & .0198 & .0196 \\ .0099 & .0098 & .0098 & .0196 \\ .0001 & .0002 & .0002 & .0004 \end{bmatrix}$$

$$\underline{\pi} = \begin{bmatrix} .9799 \\ .009999 \\ .009999 \\ .0001020 \end{bmatrix} = \begin{bmatrix} \pi_1 \\ \pi_2 \\ \pi_3 \\ \pi_4 \end{bmatrix}$$

Convergent Coupled Riccati Equations:

$$\underline{G}'_{ns} = \begin{bmatrix} -2.469 & -.1279 & -.8983 \\ -2.469 & -.1279 & -.8983 \end{bmatrix}$$

$$\underline{S}'_0 = \begin{bmatrix} 153.1 & 32.81 & 48.01 \\ 32.81 & 9.050 & 10.92 \\ 48.01 & 10.92 & 19.03 \end{bmatrix}$$

$$\underline{S}'_1 = \begin{bmatrix} 154.4 & 32.88 & 48.48 \\ 32.88 & 9.054 & 10.95 \\ 48.48 & 10.95 & 19.20 \end{bmatrix}$$

$$\underline{S}'_2 = \begin{bmatrix} 154.4 & 32.88 & 48.48 \\ 32.88 & 9.054 & 10.95 \\ 48.48 & 10.95 & 19.20 \end{bmatrix}$$

$$\underline{S}'_3 = \begin{bmatrix} 155.8 & 32.95 & 48.96 \\ 32.95 & 9.058 & 10.97 \\ 48.96 & 10.97 & 19.38 \end{bmatrix}$$

$$\sum_{i=0}^3 \pi_i \underline{S}'_i = \begin{bmatrix} 153.2 & 32.82 & 48.02 \\ 32.82 & 9.050 & 10.92 \\ 48.02 & 10.92 & 19.04 \end{bmatrix} \triangleq \underline{C}$$

Expected cost = $\underline{x}^T \underline{C} \underline{x}$

Stability:

| Configuration | Stable |
|-------------------------|--------|
| 0 (\underline{B}_0) | yes |
| 1 (\underline{B}_1) | no |
| 2 (\underline{B}_2) | no |
| 3 (\underline{B}_3) | no |

Interpretation: The steady-state non-switching gain exists; it stabilizes configuration 0 (\underline{B}_0), but does not stabilize configurations 1, 2, or 3. Since the probability of being in configuration 0 (stable) (π_0) is much greater than the probability of being in any other configuration (π_i , $i=1, 2$ or 3) (unstable), the system configuration is stabilized using the non-switching gain \underline{G}_{ns} in the control law

$$\underline{u}_t = \underline{G}_{ns} \underline{x}_t$$

Example 6.1 Case iv)

$$\begin{aligned} \underline{B}_0 &= \left[\underline{b}_1 \mid \underline{b}_1 \right] = \text{conf. 0} & \underline{B}_2 &= \left[\underline{b}_1 \mid \underline{0} \right] = \text{conf. 2} \\ \underline{B}_1 &= \left[\underline{0} \mid \underline{b}_1 \right] = \text{conf. 1} & \underline{B}_3 &= \left[\underline{0} \mid \underline{0} \right] = \text{conf. 3} \end{aligned}$$

$$\underline{R} = \begin{bmatrix} x_1 & 0.0 \\ 0.0 & x_1 \end{bmatrix} = \begin{bmatrix} 1.0 & 0.0 \\ 0.0 & 1.0 \end{bmatrix}$$

\underline{P} and $\underline{\pi}$ are the same as for Case iii).

Convergent Coupled Riccati Equations:

$$\underline{G}_{ns} = \begin{bmatrix} -6.097 & -.7347 & -2.011 \\ -6.097 & -.7347 & -2.011 \end{bmatrix}$$

$$\underline{S}'_0 = \begin{bmatrix} 762.2 & 95.14 & 195.1 \\ 95.14 & 15.18 & 24.64 \\ 195.1 & 24.64 & 52.13 \end{bmatrix}$$

$$\underline{S}'_1 = \begin{bmatrix} 768.7 & 95.92 & 197.3 \\ 95.92 & 15.27 & 24.89 \\ 197.3 & 24.89 & 52.83 \end{bmatrix}$$

$$\underline{S}'_2 = \begin{bmatrix} 768.7 & 95.92 & 197.3 \\ 95.92 & 15.27 & 24.89 \\ 197.3 & 24.89 & 52.83 \end{bmatrix}$$

$$\underline{S}'_3 = \begin{bmatrix} 775.3 & 96.71 & 199.5 \\ 96.71 & 15.36 & 25.16 \\ 199.5 & 25.16 & 53.55 \end{bmatrix}$$

$$\sum_{i=0}^3 \pi_i \underline{S}'_i = \begin{bmatrix} 762.3 & 95.15 & 195.2 \\ 95.15 & 15.18 & 24.64 \\ 195.2 & 24.64 & 52.14 \end{bmatrix} \stackrel{\Delta}{=} \underline{C}$$

$$\text{Expected cost} = \underline{x}^T \underline{C} \underline{x}$$

Stability:

| Configuration | Stable |
|-------------------------|--------|
| 0 (\underline{B}_0) | yes |
| 1 (\underline{B}_1) | no |
| 2 (\underline{B}_2) | no |
| 3 (\underline{B}_3) | no |

Interpretation: The steady-state non-switching gain exists; it stabilizes configuration 0 (\underline{B}_0), but does not stabilize configurations 1, 2, or 3. Since the probability of being in configuration 0 (stable) (π_0) is much greater than the probability of being in any other configuration (π_i , $i=1,2$ or 3) (unstable), the system configuration is stabilized using the non-switching gain \underline{G}_{ns} in the control law

$$\underline{u}_t = \underline{G}_{ns} \underline{x}_t$$

Example 6.1 Case v)

$$\begin{aligned} \underline{B}_0 &= \left[\underline{b}_0 \mid \underline{b}_1 \right] = \text{conf. } 0 & \underline{B}_2 &= \left[\underline{b}_0 \mid \underline{0} \right] = \text{conf. } 2 \\ \underline{B}_1 &= \left[\underline{0} \mid \underline{b}_1 \right] = \text{conf. } 1 & \underline{B}_3 &= \left[\underline{0} \mid \underline{0} \right] = \text{conf. } 3 \end{aligned}$$

$$\underline{R} = \begin{bmatrix} r_0 & 0.0 \\ 0.0 & r_1 \end{bmatrix} = \begin{bmatrix} 1.0 & 0.0 \\ 0.0 & 1.0 \end{bmatrix}$$

\underline{p} and $\underline{\pi}$ are the same as for Case iii).

Convergent Coupled Riccati Equations:

$$\underline{G}_{ns} = \begin{bmatrix} -3.815 & -.1312 & -1.106 \\ -2.956 & -.5815 & -1.486 \end{bmatrix}$$

$$\underline{S}'_0 = \begin{bmatrix} 126.5 & 24.86 & 32.32 \\ 24.86 & 7.066 & 6.842 \\ 32.32 & 6.842 & 10.69 \end{bmatrix}$$

$$\underline{S}'_1 = \begin{bmatrix} 128.4 & 24.93 & 32.88 \\ 24.93 & 7.096 & 6.863 \\ 32.88 & 6.863 & 10.85 \end{bmatrix}$$

$$\underline{S}'_2 = \begin{bmatrix} 127.3 & 25.01 & 32.72 \\ 25.01 & 7.097 & 6.921 \\ 32.72 & 6.921 & 10.89 \end{bmatrix}$$

$$\underline{S}'_3 = \begin{bmatrix} 129.2 & 25.08 & 33.28 \\ 25.08 & 7.100 & 6.942 \\ 33.28 & 6.942 & 11.05 \end{bmatrix}$$

$$\sum_{i=0}^3 \pi_i \underline{S}'_i = \begin{bmatrix} 126.5 & 24.86 & 32.33 \\ 24.86 & 7.067 & 6.843 \\ 32.33 & 6.843 & 10.69 \end{bmatrix} \triangleq \underline{C}$$

$$\text{Expected cost} = \underline{x}^T \underline{C} \underline{x}$$

Stability:

| Configuration | Stable |
|-------------------------|--------|
| 0 (\underline{B}_0) | yes |
| 1 (\underline{B}_1) | no |
| 2 (\underline{B}_2) | yes |
| 3 (\underline{B}_3) | no |

Interpretation: The steady-state non-switching gain exists; it stabilizes configuration 0 and 2 (\underline{B}_0 and \underline{B}_2). Since the probabilities of being in configuration 1 and 3 (\underline{B}_1 and \underline{B}_3) are small (π_1 and π_3) (unstable), the system configuration is stabilized during the non-switching gain \underline{G}_{ns} in the control law

$$\underline{u}_t = \underline{G}_{ns} \underline{x}_t$$

From the results in Example 6.1, the design configurations are ranked as follows, where $>$ is defined as "is better than".

$$\underline{B}^5 > \underline{B}^3 > \underline{B}^1 > \underline{B}^4 > \underline{B}^2 \quad (6.2.9)$$

One configuration is more desirable than another ($\underline{B}^j > \underline{B}^k$) if

$$\sum_{i=0}^{r^j} \pi_{i=i}^{j,j} - \sum_{i=0}^{r^k} \pi_{i=i}^{j,k} > 0 \quad (\text{negative definite}) \quad (6.2.10)$$

This criterion is reasonable; if $\underline{B}^j > \underline{B}^k$, then the expected cost using design configuration \underline{B}^j is always less than that using \underline{B}^k . If the left hand side of equation (6.2.10) is not negative definite, but is only semi-definite, then some other criterion must be used in addition to (6.2.10) to rank the various designs. For example, if one assumes a uniform distribution of the initial system state \underline{x}_0 in the unit sphere, and if the elements of the diagonal of the left hand side of equation (6.2.10) are all non-positive, then the trace operator may be used as a ranking function. If the trace of the left hand side of equation (6.2.10) is negative, then $\underline{B}^j > \underline{B}^k$. If the left hand side of equation (6.2.10) is not semi-definite, then the designer must choose which of the state variables are most important in an effort to eliminate the ambiguity of equation (6.2.10). In Example 6.1, equation (6.2.10) alone is sufficient to rank the designs.

The results stated in (6.2.9) are somewhat surprising. First, consider \underline{b}_0 and \underline{b}_1 . A control input at time t using \underline{b}_0 enters the system dynamics in state \underline{x}_3 , where $\underline{x}_t = [x_{1,t} \ x_{2,t} \ x_{3,t}]^T$. At time $t+1$, the same control is applied to state \underline{x}_1 with a gain of .5; also, $x_{2,t+1} = x_{3,t}$. At time $t+2$, that control is again applied to state \underline{x}_1 with a gain of .5. Now, consider

the same situation, but with \underline{b}_1 instead of \underline{b}_0 . In this case, at time $t+1$, the control is applied to state x_1 , with a gain of .5, but $x_{3,t+1} = -x_{2,t}$. Therefore, at time $t+2$, the negative value of the original control is applied to state x_1 , thus partially cancelling the effect of the original input. The same process occurs using \underline{b}_0 , but is delayed one time step; thus, the control affects state x_1 positively one additional time step when \underline{b}_0 is used. Because of the added effectiveness of \underline{b}_0 over \underline{b}_1 , $\underline{B}^1 > \underline{B}^2$, and in fact, $\underline{B}^1 > \underline{B}^4$. Thus, even after accounting for component reliability, configuration \underline{B}^1 , which has no component redundancy is more desirable than configuration \underline{B}^2 or \underline{B}^4 even though configuration \underline{B}^4 employs one level of component redundancy.

Using this reasoning, one would expect \underline{B}^3 to be the optimal design choice; however, the example demonstrates that this is not the case. From \underline{G}_{ns} for Case iv), note that the control which is applied to \underline{b}_0 depends mostly on the unstable state x_1 , while more emphasis is given to states x_2 and x_3 in the calculation of the control for actuator \underline{b}_1 . Thus, actuator \underline{b}_0 acts partially to stabilize the dynamics of state x_1 , while actuator \underline{b}_1 acts partially to counteract the negative effects of the subsystem of states x_2 and x_3 . This type of control action is an example of the use of functional redundancy, and is not possible with design configurations \underline{B}^3 or \underline{B}^4 .

The non-switching gain analysis of the proposed design configurations yields information not only about the effect of various actuator configurations but also about the effect of component reliability on the expected performance. Thus, \underline{B}^4 is more effective than \underline{B}^2 , and \underline{B}^3 is more effective than \underline{B}^1 ; \underline{B}^4 and \underline{B}^3 are versions of the configurations

\underline{B}^2 and \underline{B}^1 , respectively, with one level of component redundancy. Configuration \underline{B}^5 is an example of functional redundancy; both actuators provide control input to the same system, but are not identical components. Thus, the additional reliability of component redundancy contributes to ranking (6.2.9). The trade-off between system performance and system reliability will be further demonstrated in Section 3.

6.3 A Trade-Off of System Performance Versus Reliability.

The non-switching gain methodology can be used to study the relative effects of actuator reliability and actuator effectiveness on expected system performance. If a designer has a choice between using a high reliability actuator rather than one with relatively low reliability, but with a higher effectiveness, on what basis can a decision be made? In Example 6.2, two actuators are considered. Each actuator may fail to an actuator of gain zero (0) and be repaired (replaced). The probabilities of failure and repair are p_{f_i} and p_{r_i} , where $i=0$ or 1 and refers to the actuator (\underline{b}_0 or \underline{b}_1 ; respectively). One actuator (\underline{b}_0) has good reliability, but the actuator gain is unity. A second actuator (\underline{b}_1) has an actuator gain of ten (higher effectiveness), and a lower reliability. If the actuators had the same reliability, then actuator \underline{b}_1 would be preferable--it incurs a smaller cost for the same effect. In Case i) of Example 6.2, this reasoning is demonstrated numerically; the steady-state non-switching gain favors actuator \underline{b}_1 (the second column of \underline{B}_0). (The two rows of the gain matrix are compared; the top row corresponds to actuator \underline{b}_0 .)

In Cases ii) and iii) of Example 6.2, the reliability of actuator \underline{b}_1 is lower than the reliability of actuator \underline{b}_0 . In Case ii) the probability of failure per unit time of actuator \underline{b}_1 is five times greater than the probability of failure per unit time of actuator \underline{b}_0 ; in Case iii), it is ten times greater. The probabilities of repair per unit time for actuator \underline{b}_1 are also lower than for actuator \underline{b}_0 . Therefore, actuator \underline{b}_1 is significantly less reliable than actuator \underline{b}_0 . Note that in Case ii), the optimal non-switching steady-state controller

favors actuator \underline{b}_0 by a gain factor of 2.5 - 2.6; in Case i), actuator \underline{b}_1 is favored by a gain factor of 2.3. In Case iii), actuator \underline{b}_0 is favored by a gain factor of 5.1. Thus, the non-switching gain calculations can be quite sensitive to changes in component reliability.

Although the configuration states are identical for all three Cases of Example 6.2, the configuration dynamics are modified by the changes in actuator reliability. The effect of modifications in actuator reliability on the non-switching steady-state gain and cost is pronounced. The steady-state gain is very sensitive to the actuator reliabilities; the expected steady-state cost increases as the reliability decreases. A second effect demonstrated by Example 6.2 is interesting. In Case i), configuration state 2 is not stabilized by the non-switching gain. As the reliability of actuator \underline{b}_1 decreases, the average steady-state probability that the configuration is state 2 (actuator \underline{b}_1 failed, actuator \underline{b}_0 operational) increases. Therefore, the non-switching gain solution must concentrate more effort on stabilizing configuration state 2. Note that in Cases ii) and iii), configuration state 2 is stabilized by the non-switching gain solution. It is interesting to note also that the non-switching gains in Cases ii) and iii) are robust with respect to configuration states 0, 1 and 2. (Configuration state 3 is uncontrollable.)

The system dynamics in Example 6.2 are

$$\underline{x}_{t+1} = \underline{A} \underline{x}_t + \underline{B}_{k(t)} u_t \quad (6.3.1)$$

$$k(t) \in I \quad (6.3.2)$$

where $I = \{0, 1, 2, 3\}$ and $\underline{x}_t = [x_{1,t} \ x_{2,t} \ x_{3,t}]^T$. The set $\{\underline{B}_i\}_{i=0}^3$

of configuration states is given in Example 6.2. The cost to be

minimized is

$$J_T = E \left[\sum_{t=0}^{\infty} \underline{x}_t^T \underline{Q} \underline{x}_t + \underline{u}_t^T \underline{R} \underline{u}_t \mid \underline{\pi} \right] \quad (6.3.3)$$

Example 6.2:

$$\underline{A} = \begin{bmatrix} 2.0000 & .5000 & .5000 \\ 0.0 & 0.0 & 1.0000 \\ 0.0 & -1.0000 & 0.0 \end{bmatrix}$$

$$\underline{B}_0 = \begin{bmatrix} 0.0 & 0.0 \\ 0.0 & 0.0 \\ 1.0 & 10.0 \end{bmatrix} = \text{conf. 0} \quad \underline{B}_1 = \begin{bmatrix} 0.0 & 0.0 \\ 0.0 & 0.0 \\ 0.0 & 10.0 \end{bmatrix} = \text{conf. 1}$$

$$\underline{B}_2 = \begin{bmatrix} 0.0 & 0.0 \\ 0.0 & 0.0 \\ 1.0 & 0.0 \end{bmatrix} = \text{conf. 2} \quad \underline{B}_3 = \begin{bmatrix} 0.0 & 0.0 \\ 0.0 & 0.0 \\ 0.0 & 0.0 \end{bmatrix} = \text{conf. 3}$$

$$\underline{Q} = \begin{bmatrix} 1.0 & 0.0 & 0.0 \\ 0.0 & 1.0 & 0.0 \\ 0.0 & 0.0 & 1.0 \end{bmatrix} \quad \underline{R} = \begin{bmatrix} 5.0 & 0.0 \\ 0.0 & 5.0 \end{bmatrix}$$

$$\underline{P} = \begin{bmatrix} 1-p_{f_1}-p_{f_2}+p_{f_1}p_{f_2} & (1-p_{f_2})p_{r_1} & (1-p_{f_1})p_{r_2} & p_{r_1}p_{r_2} \\ p_{f_1}(1-p_{f_2}) & 1-p_{r_1}-p_{f_2}+p_{r_1}p_{f_2} & p_{f_1}p_{r_2} & (1-p_{r_2})p_{r_1} \\ p_{f_2}(1-p_{f_1}) & p_{f_2}p_{r_1} & 1-p_{f_1}-p_{r_2}+p_{f_1}p_{r_2} & (1-p_{r_1})p_{r_2} \\ p_{f_1}p_{f_2} & (1-p_{r_1})p_{f_2} & (1-p_{r_2})p_{f_1} & 1-p_{r_1}-p_{r_2}+p_{r_1}p_{r_2} \end{bmatrix}$$

Example 6.2 Case i)

$$P_{f_0} = .01$$

$$P_{f_1} = .01$$

$$P_{r_1} = .98$$

$$\underline{\pi} =$$

$$\begin{bmatrix} .9799 \\ .009999 \\ .009999 \\ .0001020 \end{bmatrix} = \begin{bmatrix} \pi_0 \\ \pi_1 \\ \pi_2 \\ \pi_3 \end{bmatrix}$$

Convergent:

$$\underline{G}_{ns} = \begin{bmatrix} -.2059 & -.01076 & -.07574 \\ -.4829 & -.02505 & -.1789 \end{bmatrix}$$

$$\underline{s}'_0 = \begin{bmatrix} 134.5 & 30.06 & 41.49 \\ 30.06 & 8.459 & 9.981 \\ 41.49 & 9.981 & 16.44 \end{bmatrix}$$

$$\underline{s}'_1 = \begin{bmatrix} 134.5 & 30.06 & 41.49 \\ 30.06 & 8.459 & 9.981 \\ 41.49 & 9.981 & 16.44 \end{bmatrix}$$

$$\underline{s}'_2 = \begin{bmatrix} 138.5 & 30.27 & 42.96 \\ 30.27 & 8.470 & 10.06 \\ 42.96 & 10.06 & 16.98 \end{bmatrix}$$

$$\underline{s}'_3 = \begin{bmatrix} 138.5 & 30.27 & 42.97 \\ 30.27 & 8.470 & 10.06 \\ 42.97 & 10.06 & 16.98 \end{bmatrix}$$

$$\sum_{i=0}^3 \pi_i \underline{s}'_i = \begin{bmatrix} 134.5 & 30.06 & 41.51 \\ 30.06 & 8.459 & 9.982 \\ 41.51 & 9.982 & 16.45 \end{bmatrix} \stackrel{\Delta}{=} \underline{c}$$

$$\text{Expected cost} = \underline{x}^T \underline{C} \underline{x}$$

Stability:

| Configuration | Stable |
|-------------------------|--------|
| 0 (\underline{B}_0) | yes |
| 1 (\underline{B}_1) | yes |
| 2 (\underline{B}_2) | no |
| 3 (\underline{B}_3) | no |

Interpretations: The system $\underline{x}_{t+1} = [\underline{A} + \underline{B}_i \underline{G}_{ns}] \underline{x}_t$ is stable only for $i=0$ and 1. The probabilities of the configuration being in states 2 and 3 (π_2 and π_3) are small; the system configuration is stabilized using the control gain \underline{G}_{ns} in the control law

$$\underline{u}_t = \underline{G}_{ns} \underline{x}_t$$

Example 6.2 Case ii)

$$p_{f_0} = .01 \quad p_{r_0} = .98$$

$$p_{f_1} = .05 \quad p_{r_1} = .90$$

$$\underline{\pi} = \begin{bmatrix} .9378 \\ .009212 \\ .05206 \\ .0005316 \end{bmatrix} = \begin{bmatrix} \pi_0 \\ \pi_1 \\ \pi_2 \\ \pi_3 \end{bmatrix}$$

Convergent:

$$\underline{G}_{ns} = \begin{bmatrix} -1.041 & -.05848 & -.3639 \\ -.4058 & -.02163 & -.1464 \end{bmatrix}$$

$$\underline{s}'_0 = \begin{bmatrix} 176.6 & 36.37 & 55.60 \\ 36.37 & 9.797 & 12.06 \\ 55.60 & 12.06 & 21.81 \end{bmatrix}$$

$$\underline{s}'_1 = \begin{bmatrix} 176.9 & 36.39 & 55.71 \\ 36.39 & 9.798 & 12.06 \\ 55.71 & 12.06 & 21.85 \end{bmatrix}$$

$$\underline{s}'_2 = \begin{bmatrix} 197.4 & 37.56 & 62.83 \\ 37.56 & 9.868 & 12.46 \\ 62.83 & 12.46 & 24.35 \end{bmatrix}$$

$$\underline{s}'_3 = \begin{bmatrix} 166.4 & 35.79 & 52.08 \\ 35.79 & 9.762 & 11.86 \\ 52.08 & 11.86 & 20.58 \end{bmatrix}$$

$$\sum_{i=0}^3 \pi_i \underline{s}'_i = \begin{bmatrix} 177.7 & 36.43 & 55.98 \\ 36.43 & 9.801 & 12.08 \\ 55.98 & 12.08 & 21.94 \end{bmatrix} \triangleq \underline{c}$$

$$\text{Expected cost} = \underline{x}^T \underline{C} \underline{x}$$

Stability:

| Configuration | Stable |
|-------------------------|--------|
| 0 (\underline{B}_0) | yes |
| 1 (\underline{B}_1) | yes |
| 2 (\underline{B}_2) | yes |
| 3 (\underline{B}_3) | no |

Interpretation: The system

$$\underline{x}_{t+1} = [\underline{A} + \underline{B}_i \underline{G}_{ns}] \underline{x}_t$$

is stable for $i = 0, 1, 2$.

Configuration state 2 is stabilized because the probability of the configuration state being 2 (\underline{B}_2) is larger than in Case i).

$$\begin{aligned}
 p_{f_0} &= .01 & p_{r_0} &= .98 \\
 p_{f_1} &= .10 & p_{r_1} &= .90
 \end{aligned}
 \quad \underline{\pi} = \begin{bmatrix} .8909 \\ .009172 \\ .09891 \\ .001010 \end{bmatrix} = \begin{bmatrix} \pi_0 \\ \pi_1 \\ \pi_2 \\ \pi_3 \end{bmatrix}$$

Convergent:

$$\underline{G}_{ns} = \begin{bmatrix} -1.729 & -.09453 & -.6062 \\ -.3400 & -.01858 & -.1195 \end{bmatrix}$$

$$\underline{s}'_0 = \begin{bmatrix} 210.6 & 41.04 & 67.28 \\ 41.04 & 10.76 & 13.61 \\ 67.28 & 13.61 & 26.29 \end{bmatrix}$$

$$\underline{s}'_1 = \begin{bmatrix} 213.2 & 41.14 & 68.26 \\ 41.14 & 10.75 & 13.66 \\ 68.26 & 13.66 & 26.66 \end{bmatrix}$$

$$\underline{s}'_2 = \begin{bmatrix} 212.3 & 41.09 & 67.92 \\ 41.09 & 10.75 & 13.64 \\ 67.92 & 13.64 & 26.53 \end{bmatrix}$$

$$\underline{s}'_3 = \begin{bmatrix} 196.0 & 40.19 & 62.11 \\ 40.19 & 10.70 & 13.32 \\ 62.11 & 13.32 & 24.47 \end{bmatrix}$$

$$\sum_{i=0}^3 \pi_i \underline{s}'_i = \begin{bmatrix} 210.7 & 40.99 & 67.28 \\ 40.99 & 10.75 & 13.60 \\ 67.28 & 13.60 & 26.28 \end{bmatrix} \stackrel{\Delta}{=} \underline{C}$$

$$\text{Expected cost} = \underline{x}^T \underline{C} \underline{x}$$

Stability:

| Configuration | Stable |
|-------------------------|--------|
| 0 (\underline{B}_0) | yes |
| 1 (\underline{B}_1) | yes |
| 2 (\underline{B}_2) | yes |
| 3 (\underline{B}_3) | no |

Interpretation: The system

$$\underline{x}_{t+1} = [\underline{A} + \underline{B}_i \underline{G}_{ns}] \underline{x}_t$$

is stable for $i = 0, 1, 2$.

Configuration state 2 is stabilized because the probability of the configuration state being 2 (\underline{B}_2) is larger than in Case i).

6.4 Summary.

In this Chapter, two applications of the non-switching gain methodology to computer-aided design (CAD) were presented. The purpose of these examples was to demonstrate the usefulness of the non-switching gain methodology in the design process. CAD has two uses: First, it is used by the system designer in the evaluation and design of a system. Second, it is quite useful to the theorist. In this research, for example, without CAD techniques, a thorough knowledge of the methodologies presented in this report could not have been gained. The equations describing the switching and non-switching gain methodologies can be derived, but their meaning in a specific context cannot be determined theoretically. The purpose of this research was to study the interactions between system reliability and optimal control. The methodologies presented in this report allow this study to proceed. The two Examples of this Chapter study two specific areas of interaction between system reliability and control. The door has now been opened to the answers to questions on reliable control system designs. Computer-aided design can provide the signposts to these answers.

CHAPTER 7

CRITIQUE

7.1 Introduction.

In this Chapter, the major results of the report will be summarized. In Chapters 3 and 4, the switching gain solution was developed and extended suboptimally to stochastic systems. In Chapter 5, the non-switching gain solution was developed. The problems associated with system stability, including definitions of what constitutes a stable system, and with the steady-state solutions to Problems A (Sections 3 through 5) and B (Section 6) were studied in detail in Section 7. The equivalence of the two approaches to the non-switching gain solution is proved in Section 8. The existence of a robust steady-state linear feedback control system was studied in Section 9.

In the following sections, each major result will be discussed; in Section 5, some suggestions for future directions in research will be made.

7.2 The Switching Gain Solution.

The switching gain solution was derived in Chapter 3 as a control methodology for linear system with quadratic cost criteria and variable actuator configurations. The resulting control law was to account for the failure, repair and reconfiguration of the actuators by switching the control gain on detection of a change in configuration. This type of control law is, from Chapter 1, Section 4, a class II reliable control methodology; an active (switching) controller is used with a passive

configuration design.

7.2.1 Deterministic Optimal Solution.

The switching gain solution of Chapter 2 is derived as the optimal solution for the discrete-time deterministic optimal control problem. It is the optimal control simply because the structure of the discrete-time system allows perfect observations of the system structure with one-step delay. Therefore, there is no need for the control law to have a dual effect; in fact, there can be no dual effect, since the control law does not affect the observation process, for almost all values of the control.

A minor drawback to the switching gain solution is the computational burden of iterating the Riccati-like equations (3.3.6), and solving for the optimal control using equation (3.3.7), backward in time for each time instant of the control interval, or until the steady-state solution is achieved, when one exists. Fortunately this computation is done off-line, and the various optimal gains are then stored for on-line use. On-line, the controller simply determines which structure the system was in at the previous time instant and chooses the corresponding (stored) gain. The control law is then a linear feedback control using that particular gain.

7.2.2 Non-Extendability to Stochastic Systems.

Unfortunately, the switching-gain solution does not extend optimally to systems where noise is present. When noise is present, it is no longer possible (in general) to determine exactly the previous value of the system structure. It was shown in Section 3 of Chapter 2 that

in such a case, the optimal control law exhibits a dual effect; i.e., the control law influences the measurement of the system structure. In a real-life situation, it is unlikely that a system with no internal noise will be found. Unfortunately, the optimal (dual) control law is, in practice, unsolvable due to the immense computer resources which are required.

7.2.3 Suboptimal Extensions.

Because of the dual control effect, the deterministic optimal solution is the only closed-form solution available. Thus, it is in our interest to look for suboptimal methodologies which extend the switching gain solution to the stochastic case. In Chapter 4, two of these methodologies were studied: Hypothesis testing and dual identification. While hypothesis testing is a measurement strategy, dual identification modifies the control in order to guarantee a perfect observation of the system structure with the next measurement. Both methodologies are presented in their simplest form, since the problems of stochastic control of systems with variable structure are not within the scope of this research. Two comments are in order, however: First, at least in the form presented in Chapter 4, a dual identification algorithm is computationally intensive. Since it is an on-line algorithm, a significant computational capacity may be required in its implementation. Second, it is observed that the optimal stochastic control law, if it could be calculated, would rely on both estimation and dual control, the two concepts which are represented in Chapter 4 by hypothesis testing and dual identification, respectively.

In a suboptimal implementation using dual identification, the algorithm would most likely be used only at intervals; the implementation would rely on an estimation algorithm for the remainder of the time. This scheme would attempt to minimize the degrading effect of dual identification on the state trajectory by using it only to guarantee that the estimation algorithm was tracking the system configuration properly. Thus, the system response would be roughly periodic, with the state being driven away from the origin in order to obtain an accurate estimate of the configuration, and decaying back toward zero between uses of the dual identification algorithm.

This type of control strategy deserves some attention in future research activities. It is similar to the class of self-testing systems which perform diagnostic testing of their configurations at intervals. It is also, at present, the only methodology which takes advantage of the dual property of the control law in systems with variable, imperfectly observed, structure.

7.3 The Non-Switching Gain Solution.

The non-switching gain solution of Chapter 5 was derived as an alternative to the switching gain solution of Chapter 3. Although the non-switching solution is, in general, suboptimal, the on-line complexity of the solution is less demanding than that of the switching gain solution. On-line, the non-switching gain solution has the same complexity as does the standard linear quadratic solution. Off-line, the computational requirements are equivalent to those of the switching gain solution.

7.3.1 The Necessary Conditions--Unsolvability.

When the non-switching control problem is formulated as an equivalent deterministic control problem (Chapter 5, Section 4), the necessary conditions from the matrix minimum principle [Athans,41] yield a two-point boundary value problem which is not explicitly solvable; at the present time, the solution to this problem appears intractable. The necessary conditions are used, however, in conjunction with an equivalent problem (Chapter 5, Section 6), to prove some strong properties of the solution to the equivalent problem.

7.3.2 The Equivalent Problem.

The equivalent problem formulated in Section 6 of Chapter 5 has the advantage over the original formulation that a closed-form expression for the solution can be readily obtained. From the necessary conditions of Section 5 in Chapter 5 for the original formulation, it is shown that the accumulated costs over the control interval for a specified gain sequence are identical for the two formulations. From this, in Section 8

of Chapter 5, it is shown that if the steady-state solutions to both problems exist, then they are identical. This is a major result, since the steady-state solution to the second formulation is calculable, while the solution to the first formulation is not.

7.3.3 Existence of a Stabilizing Gain.

Only one major result remains; one would hope that the steady-state solution to the second formulation exists if and only if the steady-state solution to the first formulation exists. In Section 7 of Chapter 5, the meaning of "steady-state" is precisely defined for both problems. In order for the concept of a steady-state solution to be well-defined, an exact definition of stability must be given. Two definitions are presented. Stability is defined as the usual concept of mean-square stability. A definition of cost-stability is presented as the condition when the expected cost for the infinite horizon problem (unnormalized by time) is bounded. It is proved that the solutions to the two formulations are equivalent in that one solution is cost-stabilizing if and only if the other is also. Cost stability is shown to imply mean-square stability; the reverse is not necessarily true.

7.3.4 Problems with Convergence.

There are two criticisms of the results of Chapter 5. First, although cost-stability is not implied by mean-square stability, it is possible that, for the specific form of the non-switching gain solution, the two definitions are equivalent. This is a minor point, in that the equivalence result is already very strong; it yields a procedure for the calculation of the steady-state solution to the two point boundary

value problem which converges if and only if that solution exists.

Second, there is still a minor problem concerning the convergence of the non-switching gain solution. The equivalence theorems of Chapter 5 only require the solution to have a steady-state, which may be a limit cycle. A limit cycle is still copacetic, but it is harder to implement than one gain would be. Therefore, it is desired that conditions be found for which the possibility of a limit cycle is ruled out.

Thus, two possible topics for future research are the examination of the exact relationship between cost-stability and mean-square stability for the non-switching solution and the determination of conditions for which the possibility of limit cycles as solutions is eliminated.

7.3.5 Existence of a Robust Gain.

A spin-off of the non-switching gain solution of Chapter 5 is the development of an algorithm which determines when a robust gain for a set of linear systems exists (Section 9). A robust gain is a gain which stabilizes each mode of the system configuration regardless of the configuration dynamics. This algorithm is developed by noting that the robustness problem can be reformulated as a non-switching gain problem. Since the non-switching gain is, in the steady-state case, the solution to the first formulation (Section 4, Chapter 5), and since it is stabilizing if and only if a stabilizing gain exists, then by the special structure of the robust formulation (Section 9), the steady-state non-switching gain is robust when it exists. In addition, if the non-switching solution is not cost-stabilizing, then no robust

gain exists. This is a very important result; it is unfortunate that determination of existence of the robust gain requires the solution of the non-switching gain problem. At present, however, no test on a system exists which determines when the non-switching gain solution is cost-stabilizing. It is hoped that such a test will be developed in the future.

7.4 Computer-Aided Design.

Chapter 6 demonstrates the usefulness of the non-switching gain calculations in computer-aided design (CAD). These calculations provide the backbone for comparison studies on the relative system effectiveness of various designs. In the first example, it is demonstrated that the non-switching control methodology yields a numerical value based on the expected performance of a design configuration over the effect of the structural dynamics. This example demonstrates that relatively subtle qualities of an actuator can be used to rank various actuator configurations; in this case, the ranking depends on the manner in which the control affected the system state and is not obvious on a casual inspection of the configuration.

The second example demonstrates the ability of the non-switching gain methodology to observe the trade-off between high reliability and high effectiveness in an actuator. Both qualities are desirable, but in this example, one actuator is highly reliable, while the second actuator is not as reliable, but is highly effective in that it incurs a much smaller cost in applying the same control effect to the system. The non-switching gain problem is solved for a range of actuator reliabilities for the highly effective sensor. It is demonstrated that the trend exists to depend more heavily on the high reliability sensor as the reliability of the highly effective sensor decreases, even though the operation of the highly reliable sensor incurs more cost.

Chapter 6 only touches upon the field of computer-aided design. There is much work to be done in this field, and the purpose of Chapter 6 is only to establish the usefulness of the non-switching gain methodology

in the design process. In the future, the applicability of the non-switching gain methodology to CAD should be studied in great detail; in particular, a comprehensive methodology for the application of the techniques of Chapter 5 to CAD should be developed. This methodology should include a strong argument for the validity of using the non-switching methodology in CAD. Specifically, research needs to be carried out on the relationship of the costs incurred by various design configurations; this is similar to justifying the use of the quadratic cost criterion in the linear quadratic regulator. In order to compare two designs, a valid basis of comparison, or cost index, must exist. The non-switching methodology is proposed as being a valid cost index for the class of systems for which it is applicable; this conjecture should be verified.

In addition to the usefulness of the non-switching methodology, it has been mentioned previously that a valid definition for a reliable design is that the design is cost-stabilizable. Since, for the deterministic control problem presented in Chapter 3, the switching gain solution is the optimal solution, the existence of the steady-state switching gain solution is equivalent to the stabilizability of that design. Hence, the existence of the steady-state switching gain solution is necessary and sufficient to classify a design reliable.

In theory, the computation of the steady-state switching gain solution can be used as a method in CAD for determining if a proposed design meets the minimum requirement of stabilizability. In practice, however, the proposed design will operate in a stochastic environment; therefore, the switching gain solution is not an absolute measure of the stabilizability of the design. In the future, research should be

concentrated on the development of the concept of stabilizability to more general stochastic systems than has been done previously. An example of work in this direction has been given with the Uncertainty Threshold Principle [Athans, et. al., 37], which is basically the determination of conditions of stabilizability for a specific system with a specific type of control law. The work on the existence of the non-switching gain solution for a simple system (Chapter 2, Section 7) is another example. It has been demonstrated in this research that the concepts of systems reliability and stabilizability are crucially interconnected. It is left to future research to determine more general conditions of reliability and stabilizability and to implement these conditions in computer algorithms which can be used by the designer.

7.5 Suggestions for Future Research.

Several suggestions for future research have been presented in sections 2,3 and 4 of this Chapter. In this Section, a summary of these suggestions will be given.

In Chapter 1, three classes of reliable control methodologies were given. These are

- I) Passive (Robust) Controller Design
- II) Active (Switching) Controller, Passive Configuration Design
- III) Active Controller, Active Configuration Design

Of the methodologies presented in this report, the non-switching gain design is a class I methodology, and the switching gain design is a class II methodology. Class III methodologies are not represented in this report. This class is currently largely in the realm of "blue sky" theory. Unfortunately, there is as yet no adequate model of configuration dynamics which exhibits a state and control structure. Over the next ten years, one should see much research activity in the area of class III methodologies and their control structures.

In class II methodologies, much effort should be concentrated on extensions, either optimal or suboptimal, of the switching class of control laws to stochastic systems. At present, most work has been done in estimation theory, since the difficulties associated with dual control are widely recognized. The ability of a control law to perform diagnostic testing for changes in configuration has yet to be exploited theoretically, although many heuristic algorithms have been used, both in control systems and in the more established field of fault detection

and identification in digital systems. Dual control is a form of self-testing, and can be utilized as such, even if an optimal control is not known. The dual identification methodology of Chapter 4 is an example. This field requires a large effort, and should be rich in research opportunities.

The class I methodologies are represented in this research by the non-switching gain solution. The work done in Chapter 5 on mean-square stability and cost-stability of solutions is not unique to this class of problems. Much remains to be done in the classification of what constitutes a stabilizable system, whether with respect to a non-switching control law or something more general.

Since reliability can be defined as stabilizability with respect to some class of control laws, research into the stabilizability of dynamic configuration systems is the key issue in reliable control system designs. Much work, including this research, has been done on the assumption that the system is stabilizable; however, little progress has been made in determining why a given design is stabilizable. Although iterative tests were developed in this report for determining stabilizability, a thorough understanding of the reason these tests either converge or fail to converge is lacking. Much work still must be done. With this should come a resolution of the problems with limit cycle steady-state solutions to the non-switching gain methodology.

In Chapter 6, the usefulness of the non-switching gain solution in computer-aided design was demonstrated. CAD is a field unto itself; many opportunities exist for research in this area. Unfortunately, most research is application-specific. CAD is useful not only to the designer,

but also to the researcher. It is a powerful tool in the building of the concepts of reliable control systems design, and it should be developed in parallel with any future research.

7.6 Summary.

In summary, the main purpose of this research was to establish a foundation in reliable control system design methodology which would provide the basic concept of a reliable control system. In achieving this goal, the linear quadratic variable actuator control problem was studied in some detail. Optimization problems were formulated which represented both system performance (in the quadratic performance index) and system reliability (in the expectation of the performance index over all possible structural trajectories). The optimal control law was solved analytically for the deterministic system; this was the switching gain solution. It was clearly illustrated by example in Chapter 2 that the switching gain control law could not be extended analytically to the control of stochastic systems. This example demonstrated the dual effect of the control law; in general, the control law will influence the measurement accuracy optimally (in the sense of minimizing expected cost) when the control can influence the accuracy.

Stochastic extensions to the switching gain methodology were proposed in Chapter 4. In particular, the dual identification algorithm is an illustration of the self-testing capacity of dual control laws. The study of the uses of the dual control effect in the design of reliable control systems is a promising research area of the future.

In Chapter 5, the non-switching gain solution was developed. This solution led to an algorithm for the determination of robust linear constant gain control laws for a set of linear systems with different actuator configurations. In addition, the resulting gains are optimal with respect to a given quadratic performance index and exist if and only if any robust gain exists.

In conclusion, the unifying concept of this report is: What constitutes a reliable control system, or a reliable design? A major connection was established in this research between the concepts of reliability and stabilizability. Iterative procedures were developed for the determination of whether or not a given linear system of the type considered in this report is reliable, with respect to both class I and class II controllers; i.e., non-switching and switching gain controllers, respectively.

APPENDICES

APPENDIX
TO
CHAPTER 1

DEFINITIONS FROM MIL-STD-721B
25 August 1966

RELIABILITY

The probability that an item will perform its intended function for a specified interval under stated conditions.

AVAILABILITY

A measure of the degree to which an item is in the operable and committable state at the start of the mission, when the mission is called for at an unknown (random) point in time.

DEPENDABILITY

A measure of the item operating condition at one or more points during the mission, including the effects of Reliability, Maintainability and Survivability, given the item condition(s) at the start of the mission. It may be stated as the probability that an item will (a) enter or occupy any one of its required operational modes during a specific mission, (b) perform the functions associated with those operational modes.

CAPABILITY

A measure of the ability of an item to achieve mission objectives given the conditions during the mission.

OPERABLE

The state of being able to perform the intended function.

MAINTAINABILITY

A characteristic of design and installation which is expressed as the probability that an item will be retained in or restored to a specific condition within a given period of time, when the maintenance is performed in accordance with prescribed procedures and resources.

SURVIVABILITY

The measure of the degree to which an item will withstand hostile man-made environment and not suffer abortive impairment of its ability to accomplish its designated mission.

APPENDIX
TO
CHAPTER 2

A2.1 Exact Optimal Solution for Deterministic Case, Chapter 2, Section 2.

From (2.2.7) and using dynamic programming, we wish to minimize

$$V(x_t, k(t-1), u_t, t) = E(qx_t^2 + ru_t^2 + V^*(ax_t + b_{k(t)}u_t, k(t), t+1 | x_t)) \quad (A2.1.1)$$

where $V^*(\cdot, k(t), t+1)$ represents the minimum cost-to-go, given $k(t)$ at time $t+1$.

This minimization can be carried out because x_t is known exactly at time t , and therefore π_{t-1} is known exactly by equation (2.2.10).

The control u_t is computed from

$$0 = \frac{\partial}{\partial u} \left(qx_t^2 + ru_t^2 + \pi_{0_t} V^*(ax_t + bu_t, k=0, t+1) + \pi_{1_t} V^*(ax_t + \frac{1}{b}u_t, k=1, t+1) \right) \quad (A2.1.2)$$

and the assumption that

$$V^*(x_t, k=i, t) = x_t^2 S_{i,t} \quad (A2.1.3)$$

resulting in equation (2.2.8). Equations (2.2.12) and (2.2.13) are then obtained by substitution of (2.2.8) into (A2.1.1); these equations validate assumption (A2.1.3) by induction.

6-3

A2.2 Exact Optimal Solution for Stochastic Case, $T=0, 1, 2=T_f$ (1-d example).

The formulation is the same as in A2.1, except the system is now represented by

$$x_{t+1} = a x_t + b_{k(t)} u_t + \xi_t \quad (\text{A2.2.1})$$

ξ_t is white noise with zero mean, variance \bar{E} , and probability distribution $\rho(\xi)$, which is uncorrelated with any other variable. To illustrate the complexity of the solution, the time set is chosen as $\{0, 1, 2\}$. The problem is to find u_0^* and u_1^* such that

$$V(x_0, 0) = E(J) = E \left[\sum_{t=0}^1 (x_t^2 q + u_t^2 r) + x_2^2 q \mid x_0, \pi_0 \right] \quad (\text{A2.2.2})$$

is minimized. Let V^* denote the minimum value of V . Assume

$$u_t = \phi_t(z_t) \quad (\text{A2.2.3})$$

where ϕ_t is a mapping from the information at time t (z_t) into the control space.

$$z_t = \{\pi_0, x_0, u_0, \dots, u_{t-1}, x_t\} \quad (\text{A2.2.4})$$

then

$$V^*(x_0, 0) = \min_{u_0 = \phi_0(z_0)} E \left\{ x_0^2 q + u_0^2 r + V^*(x_1, 1) \mid z_0 \right\} \quad (\text{A2.2.5})$$

by dynamic programming. Also

$$V^*(x_1, 1) = \min_{u_1 = \phi_1(z_1)} E \left\{ x_1^2 q + u_1^2 r + V^*(x_2, 2) \mid z_1 \right\} \quad (\text{A2.2.6})$$

But $V^*(x_2, 2) = x_2^2 q$, so (A2.2.6) becomes

$$V^*(x_1, 1) = \min_{u_1 = \phi_1(z_1)} E \left\{ x_1^2 q + u_1^2 r + x_2^2 q \mid z_1 \right\} \quad (\text{A2.2.7})$$

$$= \min_{u_1 = \phi_1(z_1)} E \left\{ x_1^2 q + u_1^2 r + (a x_1 + b_{k_1} u_1 + \xi_1)^2 q \mid z_1 \right\} \quad (\text{A2.2.8})$$

now, $Z_1 = \{\pi_0, x_0, u_0, x_1\}$, so

$$(A2.2.8) = \min_{u_1 = \phi_1(Z_1)} \left\{ x_1^2 q + u_1^2 r \right. \\ \left. + E \left[\sum_{i=0}^1 \pi_i(1|1) (ax_1 + b_i u_1 + \xi_1)^2 q \right] \right\} \quad (A2.2.9)$$

where $\pi_i(1|1)$ is the probability that $k_1 = i$, given Z_1 . Bringing the expectation inside the sum,

$$(A2.2.9) = \min_{u_1 = \phi_1(Z_1)} \left\{ x_1^2 q + u_1^2 r \right. \\ \left. + \sum_{i=0}^1 \pi_i(1|1) (a^2 x_1^2 + b_i^2 u_1^2 + E + 2ab_i x_1 u_1) q \right\} \quad (A2.2.10)$$

Differentiating (A2.2.10) w.r.t. u_1 and setting the result equal to

zero:

$$0 = 2ru_1 + \sum_{i=0}^1 \pi_i(1|1) (2b_i^2 u_1 + 2ab_i x_1) q \quad (A2.2.11)$$

or

$$u_1^* = - \frac{\left[\sum_{i=0}^1 \pi_i(1|1) b_i \right] qa}{r + \left[\sum_{i=0}^1 \pi_i(1|1) b_i^2 \right] q} x_1 \quad (A2.2.12)$$

Substituting (A2.2.12) back into (A2.2.10), define S_1 and T_1 as

$$T_1 = E q \quad (A2.2.13)$$

$$S_1 = (a^2 + 1) q$$

$$- a^2 \frac{\left[\sum_{i=0}^1 \pi_i(1|1) b_i \right]^2 q^2}{r + \left[\sum_{i=0}^1 \pi_i(1|1) b_i^2 \right] q} \quad (A2.2.14)$$

and

$$V^*(x_1, 1) = x_1^2 S_1 + T_1 \quad (\text{A2.2.15})$$

A few remarks must be made about the probability distribution over k_t , given Z_t or Z_{t+1} .

Notation:

$\pi_i(t|t)$ = probability that $k_t = i$, given the available information Z_t .

$\pi_i(t|t+1)$ = probability that $k_t = i$, given the available information Z_{t+1} .

From the Markov property,

$$\underline{\pi}(t|t) = \underline{P} \underline{\pi}(t-1|t) \quad (\text{A2.2.16})$$

Equation (A2.2.16) is the propagation equation for the distribution $\underline{\pi}$.

The form of the update equation is given and proved in the following

lemma:

Lemma A2.1:

$$\pi_i(t|t+1) = \frac{\rho(x_{t+1} - ax_t - b_i u_t) \pi_i(t|t)}{\sum_{j=0}^1 \rho(x_{t+1} - ax_t - b_j u_t) \pi_j(t|t)} \quad (\text{A2.2.17})$$

Proof:

Note that

$$\rho(x_{t+1} - ax_t - b_i u_t) = p(x_{t+1} | Z_t, u_t, k(t)=i)$$

where u_t is not a random variable. Also,

$$\begin{aligned} \pi_i(t|t) &= p(k(t)=i | Z_t) \\ &= \frac{p(k(t)=i, \underline{\pi}_0, x_0, u_0, \dots, x_t)}{p(\underline{\pi}_0, x_0, u_0, \dots, x_t)} \end{aligned}$$

then (A2.2.17) becomes:

$$p(k(t)=i|Z_{t+1}) = \frac{p(x_{t+1}|Z_t, u_t, k(t)=i)p(k(t)=i|Z_t)}{p(x_{t+1}|Z_t, u_t)}$$

which is Bayes rule.

Q.E.D.

Returning to equation (A2.2.5), and substituting (A2.2.15),

$$V^*(x_0, 0) = \min_{u_0 = \phi_0(Z_0)} E \left\{ x_0^2 q + u_0^2 r + x_1^2 S + T_1 | Z_0 \right\} \quad (\text{A2.2.18})$$

$$= \min_{u_0 = \phi_0(Z_0)} E \left\{ x_0^2 q + u_0^2 r + \bar{E}q + x_1^2 \left[q(1+a^2) - \frac{\left[\sum_{i=0}^1 \pi_i(1|1)b_i \right]^2 q^2 a^2}{r + \left[\sum_{i=0}^1 \pi_i(1|1)b_i^2 \right] q} \right] \middle| Z_0 \right\} \quad (\text{A2.2.19})$$

$$= \min_{u_0 = \phi_0(Z_0)} \left\{ x_0^2 q + u_0^2 r + \bar{E}q + \sum_{k_0=0}^1 \left[\sum_{k_1=0}^1 \int_{R(x_1)} x_1^2 \left[q(1+a^2) - \frac{\left[\sum_{i=0}^1 \pi_i(1|1)b_i \right]^2 q^2 a^2}{r + \left[\sum_{i=0}^1 \pi_i(1|1)b_i^2 \right] q} \right] \cdot dp(x_1|k_1, k_0, Z_0) p_{k_1 k_0} \right] \pi_{k_0, 0} \right\} \quad (\text{A2.2.20})$$

where

$$\pi_k(1|1) = \sum_{j=0}^1 p_{kj} \frac{\rho(x_1 - ax_0 - b_j u_0) \pi_{j,0}}{\sum_{i=0}^1 \rho(x_1 - ax_0 - b_i u_0) \pi_{i,0}} \quad (\text{A2.2.21})$$

Equation (A2.2.21) is a combination of equations (A2.2.16) and (A2.2.17). Equation (A2.2.20) can only be solved numerically (in general); this requires a numerical minimization of a function the computation of which requires four numerical integrations -- a difficult task.

A2.3 Exact Solution of Stochastic Case Over $T = 0, 1, 2 = T_f$ for a Specific Form of $\rho(\xi)$, Chapter 2, Section 2.3.1.

Assume, for the problem in A2.2, that

$$\rho(\xi) = \begin{cases} \frac{1}{2\sqrt{3E}} & , \text{ for } -\sqrt{3E} \leq \xi \leq \sqrt{3E} \\ 0 & , \text{ otherwise} \end{cases} \quad (\text{A2.3.1})$$

Suppose $|u_0| > 0$ is large enough such that

$$\rho((b_{k_0} - b_i)u_0 + \xi_0) = 0, \quad i \neq k_0 \text{ and } \xi_0 \in [-\sqrt{3E}, \sqrt{3E}]$$

Then

$$\sum_{i=0}^1 \pi_i (1|1) b_i = \sum_{i=0}^1 \left\{ \frac{\sum_{j=0}^1 p_{ij} \rho(x_1 - ax_0 - b_j u_0) \pi_{j,0}}{\sum_{k=0}^1 \rho(x_1 - ax_0 - b_k u_0) \pi_{k,0}} \right\} b_i \quad (\text{A2.3.2})$$

$$= \sum_{i=0}^1 \left\{ \frac{p_{ik_0} \left(\frac{1}{2\sqrt{3E}} \right) \pi_{k_0} (0|1)}{\left(\frac{1}{2\sqrt{3E}} \right) \pi_{k_0} (0|1)} b_i \right\} \quad (\text{A2.3.3})$$

$$= \sum_{i=0}^1 p_{ik_0} b_i \quad (\text{A2.3.4})$$

Similarly,

$$\sum_{i=0}^1 \pi_i (1|1) b_i^2 = \sum_{i=0}^1 p_{ik_0} b_i^2 \quad (\text{A2.3.5})$$

Then, from equation (A2.2.14),

$$s_1(k_0) = (a^2+1)q - a^2 \frac{\left[\sum_{i=0}^1 p_{ik_0} b_i \right]^2 q^2}{r + \left[\sum_{i=0}^1 p_{ik_0} b_i^2 \right] q} \quad (\text{A2.3.6})$$

From equation (A2.2.20),

$$\begin{aligned}
 V^*(x_0, 0) = & \min_{u_0 = \phi_0(z_0)} \left\{ x_0^2 q + u_0^2 r + \Xi q \right. \\
 & + \sum_{k_0=0}^1 \left[\sum_{k_1=0}^1 \int_{R(\xi_0)} (ax_0 + b_{k_0} u_0 + \xi_0)^2 \right. \\
 & \left. \left. \cdot \left\{ (a^2 + 1)q - a^2 \frac{\left[\sum_{i=0}^1 p_{ik_0} b_i \right]^2 q^2}{r + \left[\sum_{i=0}^1 p_{ik_0} b_i^2 \right] q} \right\} dp(\xi_0) p_{k_1 k_0} \right] \pi_{k_0, 0} \right\} \quad (A2.3.7)
 \end{aligned}$$

$$\begin{aligned}
 = & \min_{u_0 = \phi_0(z_0)} \left\{ x_0^2 q + u_0^2 r + \Xi q \right. \\
 & + \sum_{k_0=0}^1 \pi_{k_0, 0} \sum_{k_1=0}^1 p_{k_1 k_0} \left((a^2 x_0^2 + b_{k_0}^2 u_0^2 + 2ab_{k_0} x_0 u_0 \right. \\
 & \left. \left. + \Xi \right) \left\{ (a^2 + 1)q - a^2 \frac{\left[\sum_{i=0}^1 p_{ik_0} b_i \right]^2 q^2}{r + \left[\sum_{i=0}^1 p_{ik_0} b_i^2 \right] q} \right\} \right) \right\} \quad (A2.3.8)
 \end{aligned}$$

Differentiating with respect to u_0 , and noting that S_1 does not depend on u_0 ,

$$0 = \frac{\partial}{\partial u} V^*(x_0, 0)$$

$$= 2u_0 r + \sum_{k_0=0}^1 \pi_{k_0, 0} \sum_{k_1=0}^1 p_{k_1 k_0} (2b_{k_0}^2 u_0 + 2ab_{k_0} x_0) S_1 \quad (A2.3.9)$$

Then,

$$u_0^* = - \frac{\sum_{k_0=0}^1 \pi_{k_0,0} \sum_{k_1=0}^1 p_{k_0 k_1} b_{k_0} s_1^a}{r + \sum_{k_0=0}^1 \pi_{k_0,0} \sum_{k_1=0}^1 p_{k_1 k_0} b_{k_0}^2 s_1} x_0 \quad (A2.3.10)$$

This solution is valid only when $|u_0| > 0$ is large enough such that

$\rho((b_{k_0} - b_i)u_0 + \xi_0) = 0$, $i \neq k_0$ and $\xi_0 \in [-\sqrt{3E}, \sqrt{3E}]$. Thus,

$$|(b_{k_0} - b_i)u_0 + \xi_0| > \sqrt{3E}, \quad \xi_0 \in [-\sqrt{3E}, \sqrt{3E}] \quad (A2.3.11)$$

must be satisfied.

i) Assume $(b_{k_0} - b_i)u_0 > 0$. Then (A2.3.11) is satisfied if

$$(b_{k_0} - b_i)u_0 - \sqrt{3E} > \sqrt{3E} \quad (A2.3.12)$$

or

$$(b_{k_0} - b_i)u_0 > 2\sqrt{3E} \quad (A2.3.13)$$

ii) Assume $(b_{k_0} - b_i)u_0 < 0$. Then (A2.3.11) is satisfied if

$$(b_{k_0} - b_i)u_0 + \sqrt{3E} < -\sqrt{3E} \quad (A2.3.14)$$

or

$$(b_{k_0} - b_i)u_0 < -2\sqrt{3E} \quad (A2.3.15)$$

Therefore, u_0^* must satisfy

$$|(b_{k_0} - b_i)u_0^*| > 2\sqrt{3E} \quad (A2.3.16)$$

for (A2.3.10) to hold.

Notice also that when (A2.3.10) is the optimal solution, u_0^* is identical to the deterministic solution.

A2.4 Existence of Steady-State Solution for 1-d Example.

From Chapter 2, Section 2.2, the coupled Riccati equations for s_0 and s_1 are

$$\begin{aligned}
 s_{0,t} = & q + \frac{r[p_{11}ab s_{0,t+1} + p_{21}(a/b)s_{1,t+1}]^2}{[r + p_{11}b^2s_{0,t+1} + p_{21}(1/b^2)s_{1,t+1}]^2} \\
 & + p_{11} \left(a - \frac{b[p_{11}ab s_{0,t+1} + p_{21}(a/b)s_{1,t+1}]}{r + p_{11}b^2s_{0,t+1} + p_{21}(1/b^2)s_{1,t+1}} \right)^2 s_{0,t+1} \\
 & + p_{21} \left(a - \frac{p_{11}ab s_{0,t+1} + p_{21}(a/b)s_{1,t+1}}{b[r + p_{11}b^2s_{0,t+1} + p_{21}(1/b^2)s_{1,t+1}]} \right)^2 s_{1,t+1}
 \end{aligned} \tag{A2.4.1}$$

$$\begin{aligned}
 s_{1,t} = & q + \frac{r[p_{12}ab s_{0,t+1} + p_{22}(a/b)s_{1,t+1}]^2}{[r + p_{12}b^2s_{0,t+1} + p_{22}(1/b^2)s_{1,t+1}]^2} \\
 & + p_{12} \left(a - \frac{b[p_{12}ab s_{0,t+1} + p_{22}(a/b)s_{1,t+1}]}{r + p_{12}b^2s_{0,t+1} + p_{22}(1/b^2)s_{1,t+1}} \right)^2 s_{0,t+1} \\
 & + p_{22} \left(a - \frac{p_{12}ab s_{0,t+1} + p_{22}(a/b)s_{1,t+1}}{b[r + p_{12}b^2s_{0,t+1} + p_{22}(1/b^2)s_{1,t+1}]} \right)^2 s_{1,t+1}
 \end{aligned} \tag{A2.4.2}$$

Define

$$h_t = \frac{s_{1,t}}{s_{0,t}} \tag{A2.4.3}$$

$$\Gamma_t = \frac{S_{0,t}}{S_{0,t+1}} \quad (\text{A2.4.4})$$

Dividing both sides of equations (A2.4.1) and (A2.4.2) by $S_{0,t+1}$, manipulating terms, and using equations (A2.4.3) and (A2.4.4) yields:

$$\begin{aligned} \Gamma_t &= \frac{q}{S_{0,t+1}} + \frac{1}{S_{0,t+1}} \frac{r[p_{11}ab + p_{21}(a/b)h_{t+1}]^2}{[(r/S_{0,t+1}) + p_{11}b^2 + p_{21}(1/b^2)h_{t+1}]^2} \\ &+ p_{11} \left(a - \frac{b[p_{11}ab + p_{21}(a/b)h_{t+1}]}{(r/S_{0,t+1}) + p_{11}b^2 + p_{21}(1/b^2)h_{t+1}} \right)^2 \\ &+ p_{21} \left(a - \frac{p_{11}ab + p_{21}(a/b)h_{t+1}}{b(r/S_{0,t+1}) + p_{11}b^2 + p_{21}(1/b^2)h_{t+1}} \right)^2 h_{t+1} \end{aligned} \quad (\text{A2.4.5})$$

$$\begin{aligned} h_t \Gamma_t &= \frac{q}{S_{0,t+1}} + \frac{1}{S_{0,t+1}} \frac{r[p_{12}ab + p_{22}(a/b)h_{t+1}]^2}{[r/S_{0,t+1} + p_{12}b^2 + p_{22}(1/b^2)h_{t+1}]^2} \\ &+ p_{12} \left(a - \frac{b[p_{12}ab + p_{22}(a/b)h_{t+1}]}{(r/S_{0,t+1}) + p_{12}b^2 + p_{22}(1/b^2)h_{t+1}} \right)^2 \\ &+ p_{22} \left(a - \frac{p_{12}ab + p_{22}(a/b)h_{t+1}}{b[(r/S_{0,t+1}) + p_{12}b^2 + p_{22}h_{t+1}/b^2]} \right)^2 h_{t+1} \end{aligned} \quad (\text{A2.4.6})$$

Assume $S_{0,t}, S_{1,t} \rightarrow \infty$ as $t \rightarrow -\infty$ and $h_t \rightarrow h, \Gamma_t \rightarrow \Gamma$. Then

$$\begin{aligned} \Gamma &= p_{11} \left(a - \frac{b[p_{11}ab + p_{21}(a/b)h]}{p_{11}b^2 + p_{21}(1/b^2)h} \right)^2 \\ &+ p_{21} \left(a - \frac{p_{11}ab + p_{21}(a/b)h}{b[p_{11}b^2 + p_{21}h/b^2]} \right)^2 h \end{aligned} \quad (\text{A2.4.7})$$

and

$$\begin{aligned} h\Gamma &= p_{12} \left(a - \frac{b[p_{12}ab + p_{22}(a/b)h]}{p_{12}b^2 + p_{22}(1/b^2)h} \right)^2 \\ &+ p_{22} \left(a - \frac{p_{12}ab + p_{22}(a/b)h}{b[p_{12}b^2 + p_{22}h/b^2]} \right)^2 h \end{aligned} \quad (\text{A2.4.8})$$

Let

$$\underline{p} = \begin{bmatrix} p_{11} & p_{12} \\ p_{21} & p_{22} \end{bmatrix} = \begin{bmatrix} p_1 & 1-p_2 \\ 1-p_1 & p_2 \end{bmatrix} \quad (\text{A2.4.9})$$

Then

$$\begin{aligned} \Gamma &= p_1 \left(a - \frac{b[p_1ab + (1-p_1)(a/b)h]}{p_1b^2 + (1-p_1)(a/b^2)h} \right)^2 \\ &+ (1-p_1) \left(a - \frac{p_1ab + (1-p_1)(a/b)h}{b[p_1b^2 + (1-p_1)h/b^2]} \right)^2 h \end{aligned} \quad (\text{A2.4.10})$$

and

$$\begin{aligned} h\Gamma &= (1-p_2) \left(a - \frac{b[(1-p_2)ab + p_2(a/b)h]}{(1-p_2)b^2 + p_2(1/b^2)h} \right)^2 \\ &+ p_2 \left(a - \frac{(1-p_2)ab + p_2(a/b)h}{b[(1-p_2)b^2 + p_2(1/b^2)h]} \right)^2 h \end{aligned} \quad (\text{A2.4.11})$$

APPENDIX
TO
CHAPTER 3

Solving for h and Γ from equations (A2.4.10) and (A2.4.11), if $\Gamma > 1$, then there exists no steady-state solution.

A3.1 Proof of Theorem 1.

Assume $\underline{x}_{k,t+1} = \underline{x}_{\ell,t+1}$ for $k \neq \ell$. Then $(\underline{B}_k - \underline{B}_\ell)\underline{u}_{t-1} = 0$, which implies \underline{u}_{t-1} is in the null space of $\underline{B}_k - \underline{B}_\ell \in N(\underline{B}_k - \underline{B}_\ell)$. Now, dimension $(N(\underline{B}_k - \underline{B}_\ell)) < m$ because the \underline{B}_k 's are distinct.

Therefore,

$$\text{dimension} \left(\bigcup_{k, \ell} N(\underline{B}_k - \underline{B}_\ell) \right) < m \quad (\text{A3.1.1})$$

Therefore the set $\bigcup_{k, \ell} N(\underline{B}_k - \underline{B}_\ell)$ has measure zero in \mathbb{R}^m . Q.E.D.

A3.2 Optimal Solution for Deterministic Problem.

For the system

$$\underline{x}_{t+1} = \underline{A}\underline{x}_t + \underline{B}_k(t) \underline{u}_t \quad (\text{A3.2.1})$$

$$\underline{B}_k(t) \in \{ \underline{B}_k \}_{k=0}^L \quad (\text{A3.2.2})$$

$$\underline{\pi}_{t+1} = \underline{P}\underline{\pi}_t \quad \underline{\pi}_t \in \mathbb{R}^{L+1} \quad (\text{A3.2.3})$$

where $\underline{\pi}_{i,t}$ = probability of \underline{B}_i at time t .

Assume that

- 1) \underline{x}_t is observed exactly
- 2) then $\underline{B}_{k(t-1)}$ changes to $\underline{B}_k(t)$
- 3) then \underline{u}_t is applied

From dynamic programming, the optimal cost-to-go at time t is given

by

$$V^*(\underline{x}_t, k(t-1), t) = \min_{\underline{u}_t = \phi_t(\underline{x}_t)} E_{k(t)} \left\{ \underline{x}_t^T \underline{Q} \underline{x}_t + \underline{u}_t^T \underline{R} \underline{u}_t + V^*(\underline{x}_{t+1}, k(t), t+1) \mid \underline{x}_t \right\} \quad (\text{A3.2.4})$$

Assume

$$V^*(\underline{x}_t, k(t-1), t) = \underline{x}_t^T \underline{S}_{k,t} \underline{x}_t \quad (\text{A3.2.5})$$

Then

$$\underline{x}_t^T \underline{S}_{k,t} \underline{x}_t = \min_{\underline{u}_t = \phi_t(\underline{x}_t)} \left\{ \underline{x}_t^T \underline{Q} \underline{x}_t + \underline{u}_t^T \underline{R} \underline{u}_t + \sum_{i=0}^L p_{ik} (\underline{A}\underline{x}_t + \underline{B}_i \underline{u}_t)^T \underline{S}_{i,t+1} (\underline{A}\underline{x}_t + \underline{B}_i \underline{u}_t) \right\} \quad (\text{A3.2.6})$$

$$\leq \frac{\|\underline{\Sigma}_0\| \|\underline{Q} + \underline{G}^T \underline{R} \underline{G}\|}{1 - \|\underline{F}\|} \quad \text{for all } T.$$

215
(A5.1.10)

Q.E.D

A5.1 Proof of Theorem 1, Chapter 5.

(\Leftarrow)

$$J_T = \sum_{t=0}^{T-1} \text{tr}[\underline{\Sigma}_t (\underline{Q} + \underline{G}^T \underline{R} \underline{G})] + \text{tr}[\underline{\Sigma}_T \underline{Q}] \quad (\text{A5.1.1})$$

and $J_T < B$. Since $\underline{Q} + \underline{G}^T \underline{R} \underline{G} > 0$ and is constant for all t , this implies

$$\lim_{t \rightarrow \infty} \text{tr}[\underline{\Sigma}_t] = 0 \quad (\text{A5.1.2})$$

which is exactly Definition 1.

(\Rightarrow)

From equation (5.4.6), note that

$$(\underline{\Sigma}_{i,t+1})_{i=0}^L = F((\underline{\Sigma}_{i,t})_{i=0}^L) \quad (\text{A5.1.3})$$

where $F(\cdot)$ is linear in $(\underline{\Sigma}_{i,t})_{i=0}^L$.

Since

$$\lim_{t \rightarrow \infty} \text{tr}[\underline{\Sigma}_t] = 0 \quad (\text{A5.1.4})$$

for any choice of $\underline{\Sigma}_0$, $\|F\|$ is bounded and $\|F\| < 1$. (Otherwise,

$\exists \underline{\Sigma}_0 \ni \|F^n(\underline{\Sigma}_0)\| \not\rightarrow 0$.)

Then

$$\frac{1}{n} J_T = \sum_{t=0}^{T-1} \frac{1}{n} \text{tr}[\underline{\Sigma}_t (\underline{Q} + \underline{G}^T \underline{R} \underline{G})] + \frac{1}{n} \text{tr}[\underline{\Sigma}_T \underline{Q}] \quad (\text{A5.1.5})$$

$$\leq \sum_{t=0}^{T-1} \frac{1}{n} \text{tr}[\underline{\Sigma}_t] + \frac{1}{n} \text{tr}[\underline{Q} + \underline{G}^T \underline{R} \underline{G}] + \frac{1}{n} \text{tr}[\underline{\Sigma}_T] \frac{1}{n} \text{tr}[\underline{Q}] \quad (\text{A5.1.6})$$

$$\leq \sum_{t=0}^{T-1} \|F\|^t \|\underline{\Sigma}_0\| \|\underline{Q} + \underline{G}^T \underline{R} \underline{G}\| + \|F\|^T \|\underline{\Sigma}_0\| \|\underline{Q}\| \quad (\text{A5.1.7})$$

$$\leq \sum_{t=0}^{T-1} \|F\|^t (\|\underline{\Sigma}_0\| \|\underline{Q} + \underline{G}^T \underline{R} \underline{G}\|) \quad (\text{A5.1.8})$$

$$= \frac{1 - \|F\|^{T+1}}{1 - \|F\|} \|\underline{\Sigma}_0\| \|\underline{Q} + \underline{G}^T \underline{R} \underline{G}\| \quad (\text{A5.1.9})$$

and

$$(A3.2.6) = \min_{\underline{u}_t = \phi_t(\underline{x}_t)} \left\{ \underline{x}_t^T \underline{Q} \underline{x}_t + \underline{u}_t^T \underline{R} \underline{u}_t \right. \\ \left. + \sum_{i=0}^L P_{ik} \left[\underline{x}_t^T \underline{A}^T \underline{S}_{i,t+1} \underline{A} \underline{x}_t + \underline{u}_t^T \underline{B}_i^T \underline{S}_{i,t+1} \underline{B}_i \underline{u}_t \right. \right. \\ \left. \left. + \underline{x}_t^T \underline{A}^T \underline{S}_{i,t+1} \underline{B}_i \underline{u}_t + \underline{u}_t^T \underline{B}_i^T \underline{S}_{i,t+1} \underline{A} \underline{x}_t \right] \right\} \quad (A3.2.7)$$

Differentiating the r.h.s. of (A3.2.7) w.r.t. \underline{u}_t and setting equal to zero:

$$0 = 2 \underline{R} \underline{u}_t + \sum_{i=0}^L P_{ik} \left[2 \underline{B}_i^T \underline{S}_{i,t+1} \underline{B}_i \underline{u}_t + 2 \underline{B}_i^T \underline{S}_{i,t+1} \underline{A} \underline{x}_t \right] \quad (A3.2.8)$$

or

$$\underline{u}_{k(t-1),t}^* = - \left[\underline{R} + \sum_{i=0}^L P_{ik} \underline{B}_i^T \underline{S}_{i,t+1} \underline{B}_i \right]^{-1} \\ \cdot \sum_{i=0}^L P_{ik} \underline{B}_i^T \underline{S}_{i,t+1} \underline{A} \underline{x}_t \quad (A3.2.9)$$

is the optimal \underline{u}_t^* , given $k(t-1)$.

Since no noise is present in the system, $k(t-1)$ is obtained from

\underline{x}_t and \underline{x}_{t-1} , along with \underline{u}_{t-1} , as

$$k(t-1) = i \quad \text{iff} \quad \underline{x}_t = \underline{A} \underline{x}_{t-1} + \underline{B}_i \underline{u}_{t-1} \quad (A3.2.10)$$

Substituting (A3.2.9) into (A3.2.7), and eliminating \underline{x}_t because the equation must be true for all \underline{x}_t and the matrix equation is symmetric,

on simplification we obtain

$$\begin{aligned} \underline{s}_{k,t} = \underline{A}^T & \left\{ \sum_{i=0}^L p_{ik} \underline{s}_{i,t+1} \right. \\ & - \left[\sum_{i=0}^L p_{ik} \underline{s}_{i,t+1} \underline{B}_i \right] \left[\underline{R} + \sum_{i=0}^L p_{ik} \underline{B}_i^T \underline{s}_{i,t+1} \underline{B}_i \right]^{-1} \\ & \cdot \left. \left[\sum_{i=0}^L p_{ik} \underline{B}_i^T \underline{s}_{i,t+1} \right] \right\} \underline{A} + \underline{Q} \end{aligned} \quad (\text{A3.2.11})$$

which verifies assumption (A3.2.5) by induction, along with the initial condition

$$\underline{s}_{k,T} = \underline{Q} \quad (\text{A3.2.12})$$

A3.3 Proof of Lemma 1.

Consider the optimization of the cost-to-go given $k(t-1)$ at time t with final time T . This optimal cost-to-go is simply

$$V_T^*(\underline{x}_t, k(t-1), t) \quad (\text{A3.3.1})$$

where T denotes the final time. For the process with final time $T+1$, the optimal cost-to-go is

$$\begin{aligned} V_{T+1}^*(\underline{x}_t, k(t-1), t) \\ = E \left\{ \sum_{\tau=t}^T \underline{x}_\tau^T \underline{Q} \underline{x}_\tau + \underline{u}_\tau^T \underline{R} \underline{u}_\tau + \underline{x}_{T+1}^T \underline{Q} \underline{x}_{T+1} \mid k(t-1) \right\} \end{aligned} \quad (\text{A3.3.2})$$

Since this optimal sequence is not necessarily optimal for the problem with final time T , it must not incur less cost over $\{t, \dots, T\}$.

$$\begin{aligned} V_{T+1}^*(\underline{x}_t, k(t-1), t) \\ \geq V_T^*(\underline{x}_t, k(t-1), t) \\ + E \left\{ \underline{u}_T^T \underline{R} \underline{u}_T + \underline{x}_{T+1}^T \underline{Q} \underline{x}_{T+1} \mid k(t-1) \right\} \end{aligned} \quad (\text{A3.3.3})$$

Since the expectation term of equation (A3.3.3) is non-negative,

$$V_{T+1}^*(\underline{x}_t, k(t-1), t) \geq V_T^*(\underline{x}_t, k(t-1), t) \quad (\text{A3.3.4})$$

Now, note that

$$V_T^*(\underline{x}_t, k(t-1), t) = \underline{x}_t^T \underline{S}_{i, t, T} \underline{x}_t \quad (\text{A3.3.5})$$

and that equation (3.3.6) depends only on the number of iterations

$(T-t)$ for the calculation of $\underline{S}_{i, t, T}$, and therefore,

$$V_T^*(\underline{x}_t, k(t-1), t-1) = V_{T+1}^*(\underline{x}_t, k(t-1), t) \quad (\text{A3.3.6})$$

Therefore, $\{\underline{S}_{i,t}\}_{t=\tau}^{\infty}$ is an increasing sequence in that

$$\underline{S}_{i,t-1} - \underline{S}_{i,t} \geq 0 \quad (\text{A3.3.7})$$

Since, by hypothesis, V_{τ}^* is bounded over t , the $\underline{S}_{i,t}$ converge.

Q.E.D.

APPENDIX
TO
CHAPTER 5

A 5.2 Proof of Remark on Theorem 1, Chapter 5.

$$J_T = \sum_{t=0}^{T-1} \text{tr}[\underline{\Sigma}_t (\underline{Q} + \underline{G}_t^T \underline{R} \underline{G}_t)] + \text{tr}[\underline{\Sigma}_T \underline{Q}] \quad (\text{A5.2.1})$$

and

$$\sum_{t=0}^T \text{tr}[\underline{\Sigma}_t \underline{Q}] \leq J_T \quad (\text{A5.2.2})$$

Since $\underline{Q} > 0$

$$\sum_{t=0}^T \text{tr}[\underline{\Sigma}_t] \text{ is bounded.} \quad (\text{A5.2.3})$$

Therefore

$$\text{tr}[\underline{\Sigma}_t] \rightarrow 0 \text{ as } t \rightarrow \infty. \quad (\text{A5.2.4})$$

The reverse implication is shown to be false by example*

Example 1: Consider

$$x_{t+1} = u_t \quad (\text{A5.2.5})$$

$$u_t = \sqrt{\frac{t}{t+1}} x_t \quad (\text{A5.2.6})$$

Then

$$E[x_t^2] = \frac{1}{t+1} \Sigma_0 \rightarrow 0 \quad (\text{A5.2.7})$$

but

$$\sum_{t=0}^T E[x_t^2] = \Sigma_0 \sum_{t=0}^T \frac{1}{t+1} \rightarrow \infty \quad (\text{A5.2.8})$$

* Example 1 is provided by Dr. D. Castanon of ESL.

A5.3 Proof of Theorem 2, Chapter 5.

$$\text{Let } I = \{0, 1, 2, \dots, L\} \quad (\text{A5.3.1})$$

and

$$\mathcal{L}^\infty(I) = \{(k(0), k(1), \dots) \mid k(i) \in I\} \quad (\text{A5.3.2})$$

Define the function μ on the cylinder sets of $\mathcal{L}^\infty(I)$

$$K = \{(k(0), k(1), \dots) \mid k(i) \text{ fixed for } i < T\} \quad (\text{A5.3.3})$$

for arbitrary T by

$$\mu(k) = \pi_{k(0)} P_{k(1)k(0)} \cdot P_{k(2)k(1)} \cdot \dots \cdot P_{k(T)k(T-1)} \quad (\text{A5.3.4})$$

where π_0 is the initial probability distribution over I and $\underline{P} = (p_{ij})$ is the stochastic matrix of transition probabilities for the Markov chain. By a theorem of Andersen and Jessen [Loeve, p.91,42], this function defines a measure, μ , on the σ -algebra of $\mathcal{L}^\infty(I)$ generated by the cylinder sets, $\sigma(\mathcal{L}^\infty(I))$. Since $\mu(\mathcal{L}^\infty(I)) = 1$, from the definition of μ on the cylinder sets of $\mathcal{L}^\infty(I)$,

$$\mu: \sigma(\mathcal{L}^\infty(I)) \rightarrow [0,1] \quad (\text{A5.3.5})$$

is a probability measure, and since μ extends uniquely from the cylinder sets, it is the probability of occurrence of elements of $\sigma(\mathcal{L}^\infty(I))$.

Let

$$J_T(\bar{x}) : \mathbb{R}^n \rightarrow [0, \infty] \quad (\text{A5.3.6})$$

$$J_T(\bar{x})(\underline{x}) = \sum_{t=0}^{T-1} \underline{x}_t \underline{Q} \underline{x}_t + \underline{u}_t \underline{R} \underline{u}_t + \underline{x}_T \underline{Q} \underline{x}_T \quad (\text{A5.3.7})$$

where

$$\underline{x}_{t+1} = \underline{A} \underline{x}_t + \underline{B}_{k(t)} \underline{u}_t \quad (\text{A5.3.8})$$

$$\underline{u}_t = \underline{G}_t \underline{x}_t \quad (\text{A5.3.9})$$

$$\bar{x} = (k(0), k(1), k(2), \dots) \quad (\text{A5.3.10})$$

and let

$$J = \lim_{T \rightarrow \infty} J_T \quad (\text{A5.3.11})$$

Since J_T is constant on the cylinder sets with fixed sequences of length $T+1$, J_T is measurable. (There are a finite number of such sets.) By Theorem A of [Halmos, p.84,10], J is measurable with respect to μ .

$$J(\cdot)(\underline{x}) : \ell^\infty(I) \rightarrow [0, \infty] \quad (\text{A5.3.12})$$

Let

$$X_1 = \{ \bar{x} \in \ell^\infty(I) \mid J(\bar{x})(\underline{x}) < \infty \text{ for } \underline{x} \in \mathbb{R}^n \} \quad (\text{A5.3.13})$$

and

$$X_2 = \ell^\infty(I) - X_1 \quad (\text{A5.3.14})$$

Then X_1 and X_2 are measurable subsets of $\ell^\infty(I)$, and therefore

$$E[J] < \infty \Leftrightarrow \mu(X_2) = 0 \quad (\text{A5.3.15})$$

because $J(\bar{x})$ is a non-negative function on \mathbb{R}^1 .

But

$$E_x[E[J]] = \text{tr}[\sum_{-0} S_{-0}] \quad (\text{A5.3.16})$$

from equation (5.7.14), and by hypothesis, r.h.s (A5.3.16) is finite.

Therefore, any trajectory \bar{x} is an element of X_1 with probability 1,

and has finite cost.

Therefore, $\{G_t\}_{t=0}^\infty$ cost-stabilizes (5.3.1) with probability 1. Q.E.D.

A5.4. Proof of Theorem 3, Chapter 5.

Notation: In the proof, the sequences $(\underline{G}_t^*)_{t=0}^\infty$ and $(\underline{G}_{ns_t})_{t=0}^\infty$ will be referred to by \underline{G}^* and \underline{G}_{ns} respectively.

Proof:

I) (\Rightarrow) Suppose \underline{G}_{ns} is cost-stabilizing. Then $J(\underline{G}_{ns}) < \infty$.

But \underline{G}^* minimizes J . Therefore, $J(\underline{G}^*) < J(\underline{G}_{ns}) \Rightarrow J(\underline{G}^*) < \infty$.

Thus, \underline{G}^* is cost-stabilizing.

II) (\Leftarrow) Suppose \underline{G}^* is cost-stabilizing. Then $J(\underline{G}^*) < \infty$ where

$$J(\underline{G}^*) = \lim_{T \rightarrow \infty} J_T(\underline{G}^*) \quad (\text{A5.4.1})$$

Since $E_x [J_{ns_T}(\underline{G})] = J_T(\underline{G})$,

$$J(\underline{G}^*) = \lim_{T \rightarrow \infty} E_x [J_{ns_T}(\underline{G}^*)] = E_x [J_{ns}(\underline{G}^*)] \quad (\text{A5.4.2})$$

which implies

$$J_{ns}(\underline{G}^*) < \infty \quad (\text{A5.4.3})$$

Since \underline{G}_{ns} minimizes J_{ns} , then

$$J_{ns}(\underline{G}_{ns}) \leq J_{ns}(\underline{G}^*) < \infty \quad (\text{A5.4.4})$$

and, since $E_x [J_{ns_T}] = J_T$ for all T , for fixed \underline{G} ,

$$J(\underline{G}_{ns}) < \infty. \quad (\text{A5.4.5})$$

which implies that \underline{G}_{ns} is stabilizing.

Q.E.D.

A5.5 Proof of Lemma 2, Chapter 5.

For the control interval starting at time 0 and ending at time T, the expected cost for the optimal control G_t^* is

$$J_T^* = \text{tr}[\underline{\Sigma}_0 \underline{S}_0(T)] \quad (\text{A5.5.1})$$

from equation (5.5.8), where the subscript T refers to the endpoint of the control interval. Similarly, for the same process ending at T+1, the optimal expected cost is

$$J_{T+1}^* = \text{tr}[\underline{\Sigma}_0 \underline{S}_0(T+1)] \quad (\text{A5.5.2})$$

$$\begin{aligned} &= E \left[\sum_{t=0}^T \underline{x}_t^T (\underline{Q} + \underline{G}_t^{*(T+1)T} \underline{R} \underline{G}_t^{*(T+1)} \underline{x}_t \right. \\ &\quad \left. + \underline{x}_{T+1}^T \underline{Q} \underline{x}_{T+1} \mid \underline{\Sigma}_0, \underline{\pi}_0 \right] \quad (\text{A5.5.3}) \end{aligned}$$

$$\begin{aligned} &= E \left[\sum_{t=0}^{T-1} \underline{x}_t^T (\underline{Q} + \underline{G}_t^{*(T+1)T} \underline{R} \underline{G}_t^{*(T+1)} \underline{x}_t \right. \\ &\quad \left. + \underline{x}_T^T \underline{Q} \underline{x}_T \mid \underline{\Sigma}_0, \underline{\pi}_0 \right] \\ &\quad + E \left[\underline{x}_T^T (\underline{G}_T^{*(T+1)T} \underline{R} \underline{G}_T^{*(T+1)} \underline{x}_T + \underline{x}_{T+1}^T \underline{Q} \underline{x}_{T+1} \mid \underline{\Sigma}_0, \underline{\pi}_0 \right] \quad (\text{A5.5.4}) \end{aligned}$$

The first expectation of equation (A5.5.4) is the cost corresponding to the interval $[0, T]$, and must be greater than or equal to J_T^* ; the second term is positive. Therefore,

$$J_{T+1}^* \geq J_T^* \quad (\text{A5.5.5})$$

Since J_T^* is bounded by hypothesis for all T, there exists a J^* such that

$$\lim_{T \rightarrow \infty} J_T^* = J^* \quad (\text{A5.5.6})$$

Q.E.D.

A5.6 Proof of Lemma 3, Chapter 5.

By direct computation,

$$J_{T+1}(\underline{G}) = J_T(\underline{G}) + E[\underline{x}_T^T \underline{G}^T \underline{R} \underline{G} \underline{x}_T + \underline{x}_{T+1}^T \underline{Q} \underline{x}_{T+1}] \quad (\text{A5.6.1})$$

and since the expectation is positive,

$$J_{T+1}(\underline{G}) > J_T(\underline{G}) \quad (\text{A5.6.2})$$

Since $J_T(\underline{G})$ is bounded, it converges.

Q.E.D.

A5.7 Proof of Theorem 4, Chapter 5.

A) $\underline{G}_{ns_t} \rightarrow \underline{G}_{opt}$ because \underline{G}_{ns_t} converges to the steady-state value which minimizes the infinite-time horizon cost $J_{ns_{ss}}$, and therefore, by the argument given above, also minimizes equation (5.8.9).

B) Given $\epsilon > 0$, a $T > 0$ can be chosen which guarantees $\|\underline{G}_t^* - \underline{G}^*\| < \epsilon$, $\|\underline{\Sigma}_{i,t}^* - \underline{\Sigma}_i^*\| < \epsilon$ and $\|\underline{\Pi}_t - \underline{\Pi}\| < \epsilon$, for all $t > T$.

Then, by the Principle of Optimality, the sequence $\{\underline{G}_t^*\}_{t=T}^{\infty}$ minimizes the infinite-horizon cost-to-go at time T . Consider the problem $\min_{\underline{G}} J_{ss}(\underline{G})$ for initial condition $\underline{\Sigma}_i, \underline{\Pi}$, which has a solution \underline{G}_{ns}^* independent of $\underline{\Sigma}_i$. In the limit as $\epsilon \rightarrow 0$, the sequence $\{\underline{G}_t^*\}_{t=T(\epsilon)}^{\infty}$ approaches the constant sequence of gains \underline{G}^* . Suppose $\exists \delta > 0 \ni V_{T(\epsilon)}^*$,

the optimal cost-to-go, satisfies

$$V_{T(\epsilon)}^* \leq J_{ss}^* - \delta \quad (\text{A5.7.1})$$

Then the sequence of constant gains \underline{G}^* would yield a strictly lower cost $J_{ss}(\underline{G}^*)$

$$J_{ss}(\underline{G}^*) < J_{ss}^* \quad (\text{A5.7.2})$$

since $V_{T(\epsilon)}^*$ approaches the optimal cost-to-go, given the constant sequence of gains \underline{G}^* , in the limit, which is the solution to the equivalent problem $\min_{\underline{G}} J_{ss}(\underline{G})$ for initial conditions $\underline{\Sigma}_i, \underline{\Pi}$.

Therefore

$$\underline{G}^* = \underline{G}_{ns} \quad (\text{A5.7.3})$$

Q.E.D.

COMPUTER ROUTINES

AIM FORTRAN

SUBROUTINE AIM(NAA, NA, NB, NQ, NR, NG, NS, NRA, N, M, KCON, A, B, R, Q, P,
1 SBT, E, S, SB, U, V, W, X, Y, PR, PZ, GNORM, RAD, RADINV, BSB, WORK, IPVT, IEND,
2 IPRT)

C
C

*****PARAMETERS:

INTEGER NAA, NA, NB, NQ, NR, NG, NS, NRA, N, M, KCON, IPVT(N), IEND, IPRT
DOUBLE PRECISION BSB(NS, NAA, KCON), X(NA, N), RAD(NRA, N), RADINV(NRA, N)
DOUBLE PRECISION E(KCON), SBT(NS, N), A(NA, NAA), B(NB, NAA, KCON)
DOUBLE PRECISION Q(NQ, N), R(NR, M), P(NA, KCON), S(NS, NAA, KCON)
DOUBLE PRECISION SB(NS, NAA, KCON), U(NA, N), V(NA, N), W(NA, N), Y(NA, N)
DOUBLE PRECISION PR(N), WORK(N), PZ(N), GNORM(NG, NAA, KCON)

C
C

*****LOCAL VARIABLES:

DOUBLE PRECISION COND
INTEGER KIN, KOUT, I, K, KKM1, KK, J, JEND, L, KP, KM1, ICTM1, LM1
INTEGER ICOUNT

C
C

*****SUBROUTINES CALLED;

MCQ, MADD, MLINEQ, TRNATB, MMUL, MSCALE, MATIO, EIGVAL, WEIGHT, TRNATA

C
C

.....

C
C

*****PURPOSE:

THIS DOUBLE PRECISION SUBROUTINE COMPUTES THE STEADY-STATE OPTIMAL
SOLUTION AND THE CORRESPONDING OPTIMAL GAINS FOR THE PROBLEM
DESCRIBED IN THE PUBLICATION: 'ON THE RELATIONSHIP BETWEEN
RELIABILITY AND LINEAR QUADRATIC OPTIMAL CONTROL'
BY J. DOUGLAS BIRDWELL AND M. ATHANS.
(EQUATIONS (29) AND (30)).

C
C

*****PARAMETER DESCRIPTION:

ON INPUT:

NAA THE SECOND DIMENSION OF THE ARRAYS S, SB, GNORM,
BSB, B AS DECLARED IN THE CALLING PROGRAM
DIMENSION STATEMENT;

C
C

NA, NB, NQ, NR, THE FIRST DIMENSION OF THE ARRAYS
NG, NS, NRA A (AND P, X, U, V, W, Y), B (AND BSB), Q, R, GNORM,
S (AND SB, SBT), RAD (AND RADINV) RESPECTIVELY
AS DECLARED IN THE CALLING PROGRAM DIMENSION
STATEMENT;

C
C

N THE NUMBER OF STATES;

C
C

M THE NUMBER OF OBSERVATIONS;

C
C

KCON THE NUMBER OF CONFIGURATIONS;

C
C

A N BY N SYSTEM MATRIX;

C
C

ORIGINAL PAGE IS
OF POOR QUALITY

AIM FORTRAN

```

C
C      B          N BY M BY KCON SET OF INPUT MATRICES ;
C
C      R          M BY M CONTROL WEIGHTING MATRIX;
C
C      Q          N BY N STATE WEIGHTING MATRIX;
C
C      P          KCON BY KCON PROBABILITY MATRIX;
C
C      E          VECTOR OF LENGTH KCON CONTAINING THE NORMALIZED
C                  EIGENVECTOR OF P CORRESPONDING TO THE EIGENVALUE
C                  ONE ;
C
C      ON OUTPUT:
C      PR, PZ          SCRATCH VECTORS OF LENGTH N ;
C
C      U, V, W, SBT,   N BY N SCRATCH ARRAYS ;
C      X, Y
C
C      S          N BY N BY KCON SET OF SOLUTIONS ;
C
C      SB, BSB       N BY N BY KCON SCRATCH ARRAYS ;
C
C      QNORM        N BY M BY KCON ARRAY WHICH WILL CONTAIN THE
C                  GAIN MATRICES FOR THE NORMAL LINEAR QUADRATIC
C                  GAUSSIAN PROBLEM ;
C
C      RAD, RADINV   N BY N SCRATCH ARRAYS ;
C
C      WORK         SCRATCH VECTOR OF LENGTH N ;
C
C      IPVT         SCRATCH VECTOR OF LENGTH N ;
C
C      IEND        NUMBER OF ITERATIONS USED IN SOLVING BOTH THE
C                  LINEAR QUADRATIC GAUSSIAN PROBLEM AND THE
C                  PROBLEM DESCRIBED ABOVE ;
C
C      IPRT        FIRST ITERATION AT WHICH THE SOLUTIONS WILL BE
C                  PRINTED ;
C

```

```

COMMON/INOU/KIN, KOUT
ICOUNT = 0
DO 215 KK=1, KCON
  DO 4 J=1, N
    DO 3 I=1, N
3      Y(I, J)= 0.000
4      Y(J, J)= 1.000
    DO 210 K=1, IEND
      CALL MQF(NA, NB, NA, N, M, Y, B(1, 1, KK), U, WORK)

```

AIM FORTRAN

ORIGINAL PAGE IS
OF POOR QUALITY

```

      CALL MADD (NA, NR, NA, M, M, U, R, U)
      DO 14 J=1, M
        DO 13 I=1, M
13          V (I, J)= 0. 000
14          V (J, J)= 1. 000
      CALL MLINEQ (NA, NA, M, M, U, V, COND, IPVT, WORK)
      CALL TRNATB (NA, NB, N, M, B (1, 1, KK), X)
      CALL MMUL (NA, NA, NA, N, M, N, X, Y, U)
      CALL MMUL (NA, NA, NA, N, M, N, U, A, X)
      CALL MCF (NA, NA, NRA, M, N, V, X, RAD, WORK)
      CALL MSCALE (NRA, N, N, -1. 000, RAD)
      CALL MCF (NA, NA, NA, N, N, Y, A, U, WORK)
      CALL MADD (NA, NA, NA, N, N, U, Q, U)
      CALL MADD (NA, NRA, NA, N, N, U, RAD, Y)
210  CONTINUE
      KKM1 = KK - 1
      WRITE (KOUT, 44441)
      WRITE (KOUT, 44442) KKM1
      CALL MATIO (NA, N, N, Y, 3)
      CALL MMUL (NG, NA, NA, N, M, M, V, X, GNORM (1, 1, KK))
      CALL MSCALE (NG, M, N, -1. 000, GNORM (1, 1, KK))
      CALL MMUL (NB, NG, NA, N, N, M, B (1, 1, KK), GNORM (1, 1, 1), V)
      WRITE (KOUT, 60000)
      CALL MATIO (NG, M, N, GNORM (1, 1, KK), 3)
      CALL MADD (NA, NA, NA, N, N, V, A, V)
      WRITE (KOUT, 44443)
      CALL MATIO (NA, N, N, V, 3)
      CALL EIGVAL (NA, N, V, V, FR, PZ, WORK, IPVT)
215  CONTINUE
      JEND= 1
      WRITE (KOUT, 80000)
      CALL MATIO (NA, KCON, KCON, P, 3)
      DO 35 K=1, KCON
        DO 30 J=1, N
          DO 40 I=1, N
            S (I, J, K)= 0. 000
40          CONTINUE
30          S (J, J, K)= 1. 000
35  CONTINUE
C      START ITERATION TO CALCULATE S (1), S (2), . . . S (K), GOPT
C
C      CALCULATE SB
      I CONTINUE
      DO 50 K=1, KCON
        CALL MMUL (NS, NB, NS, M, N, N, S (1, 1, K), B (1, 1, K), SB (1, 1, K))
50  CONTINUE
      CALL WEIGHT (NS, NAA, KCON, NS, N, M, E, SB, SBT)
C
C      CALCULATE RADICAL

```

AIM FORTRAN

```

      DO 55 K=1, KCON
        CALL MQF (NS, NB, NB, N, M, S(1, 1, K), B(1, 1, K), BSB(1, 1, K), WORK)
55    CONTINUE
      CALL WEIGHT (NB, NAA, KCON, NRA, M, M, E, BSB, RAD)
      CALL MADD (NRA, NR, NA, M, M, RAD, R, U)
      DO 54 J=1, M
        DO 53 I=1, M
53          RADINV(I, J) = 0.000
54          RADINV(J, J) = 1.000
          CALL MLINEQ (NA, NRA, M, M, U, RADINV, COND, IPVT, WORK)
C
C    CALCULATE NEW SI, I=1, 2, . . . . ., KCON
100  DO 1000 K=1, KCON
      CALL MMUL (NS, NRA, NA, M, N, M, SBT, RADINV, U)
      CALL WEIGHT (NS, NAA, KCON, NA, N, M, P(1, K), SB, V)
      CALL TRNATB (NA, NA, N, M, V, W)
      CALL MMUL (NA, NA, NA, N, N, M, U, W, X)
      CALL TRNATB (NA, NA, N, M, U, W)
      CALL MMUL (NA, NA, NA, N, N, M, V, W, Y)
      CALL MADD (NA, NA, NA, N, N, X, Y, X)
      CALL MSCALE (NA, N, N, -1.000, X)
      CALL TRNATA (NA, N, X)
      CALL WEIGHT (NA, NAA, KCON, NA, N, N, P(1, K), S, V)
      CALL MADD (NA, NA, NA, N, N, X, V, X)
      CALL WEIGHT (NB, NAA, KCON, NA, M, M, P(1, K), BSB, Y)
      CALL MADD (NA, NA, NA, M, M, Y, R, Y)
      CALL MMUL (NA, NA, NA, M, N, M, U, Y, V)
      CALL MMUL (NA, NA, NA, N, N, M, V, W, Y)
      CALL MADD (NA, NA, NA, N, N, X, Y, X)
      CALL MQF (NA, NA, NA, N, N, X, A, U, WORK)
      CALL MADD (NQ, NA, NS, N, N, Q, U, S(1, 1, K))
1000 CONTINUE
      IF (ICOUNT-1END) 11, 12, 12
11    ICOUNT = ICOUNT + 1
      IF (ICOUNT.LT.IPRT) GO TO 1
      ICTM1 = ICOUNT - 1
      WRITE (KOUT, 5000) ICTM1
      DO 1005 K=1, KCON
        KM1 = K-1
        WRITE (KOUT, 4000) KM1
        CALL MATIO (NS, N, N, S(1, 1, K), 3)
1005 CONTINUE
      GO TO 1
12    CONTINUE
C
C    COMPUTE OPTIMAL COST FUNCTION
      CALL WEIGHT (NA, NAA, KCON, NA, N, N, E, S, U)
      WRITE (KOUT, 7000)
      CALL MATIO (NA, N, N, U, 3)

```

AIM FORTRAN

```

      GO TO (23, 22), JEND
C
C   COMPUTE G OPT
23 CALL MMUL (NA, NA, NA, N, M, N, W, A, U)
   CALL MSCALE (NA, N, N, -1.0D0, U)
   WRITE (KOUT, 6000)
   CALL MATIO (NA, M, N, U, 3)
   DO 217 KP=1, KCON
      CALL MMUL (NA, NB, NA, N, N, M, B(1, 1, KP), U, W)
      CALL MADD (NA, NA, NA, N, N, A, W, W)
      CALL EIGVAL (NA, N, W, W, PR, PZ, WORK, IPVT)
217 CONTINUE
C
C   CALCULATE COMPARISON WITH GNORM
      ICOUNT= 0
      DO 130 K=1, KCON
         DO 120 J=1, N
            DO 110 I=1, N
               S (I, J, K) = 0.0D0
110      CONTINUE
120      S (J, J, K) = 1.0D0
130      CONTINUE
      JEND= 2
400      CONTINUE
      DO 98 K=1, KCON
         CALL WEIGHT (NS, NAA, KCON, NA, N, N, P(1, K), S, U)
         CALL MQF (NA, NA, NA, N, N, U, A, X, WORK)
         DO 96 L=1, KCON
            CALL MQF (NS, NB, NS, N, M, S(1, 1, L), B(1, 1, L), SB(1, 1, L), WORK)
96      CONTINUE
         CALL WEIGHT (NS, NAA, KCON, NA, M, M, P(1, K), SB, Y)
         CALL MQF (NA, NA, NA, M, N, Y, GNORM(1, 1, K), U, WORK)
         CALL MADD (NA, NA, NA, N, N, U, X, X)
         DO 95 L=1, KCON
            CALL MMUL (NS, NB, NS, M, N, N, S(1, 1, L), B(1, 1, L), SB(1, 1, L))
95      CONTINUE
         CALL WEIGHT (NS, NAA, KCON, NA, N, M, P(1, K), SB, Y)
         CALL TRNATB (NA, NA, N, M, Y, W)
         CALL TRNATA (NA, N, A)
         CALL MMUL (NA, NA, NA, M, N, N, A, Y, V)
         CALL MMUL (NA, NG, NA, N, N, M, V, GNORM(1, 1, K), Y)
         CALL MADD (NA, NA, NA, N, N, Y, X, X)
         CALL TRNATB (NG, NA, M, N, GNORM(1, 1, K), V)
         CALL MMUL (NA, NA, NA, N, N, M, V, W, U)
         CALL TRNATA (NA, N, A)
         CALL MMUL (NA, NA, NA, N, N, N, U, A, W)
         CALL MADD (NA, NA, NA, N, N, W, X, X)
         CALL MADD (NA, NA, NA, N, N, X, Q, X)
         CALL MQF (NR, NG, NA, M, N, R, GNORM(1, 1, K), U, WORK)

```

ORIGINAL PAGE IS
OF POOR QUALITY

AIM FORTRAN

```

      CALL MADD (NA, NA, NA, N, N, X, U, X)
      CALL SAVE (NA, NS, N, N, X, S(1, 1, K))
  98 CONTINUE
      IF(ICOUNT-IENTD) 4010, 4011, 4011
4010 ICOUNT= ICOUNT + 1
      GO TO 400
4011 WRITE (KOUT, 9000)
      CALL MQF (NA, NA, NA, N, N, X, A, U, WORK)
      DO 1006 L=1, KCON
          LM1 = L-1
          WRITE (KOUT, 4000) LM1
          CALL MATIO (NS, N, N, S(1, 1, L), 3)
1006 CONTINUE
      GO TO 12
4000 FORMAT (/, 4I  S, I5, /)
5000 FORMAT (//, 11H ITERATION , I3)
6000 FORMAT (//, 10H G OPTIMAL )
7000 FORMAT (//, 39H OPTIMAL COST FUNCTION X'CX, WHERE C IS, /)
8000 FORMAT (//, 3H  P, /)
9000 FORMAT (//, 38H COST COMPARISON WITH NORMAL SOLUTION
9500 FORMAT (2D25.15)
9600 FORMAT (/, 3H A )
9700 FORMAT (/, 3H Q )
9800 FORMAT (/, 3H R )
9900 FORMAT (/, 3H  B, I5, /)
44442 FORMAT (/, 3H S , I5, /)
44443 FORMAT (/, 13H  A + B*GZERO)
44441 FORMAT (/, 45H SOLUTION TO STANDARD OPTIMAL CONTROL PROBLEM)
  2 STOP
  22 RETURN
      END

```

SWTICH FORTRAN

```

C
C      KCON      THIRD DIMENSION OF THE ARRAYS B AND G AS
C                DECLARED IN THE CALLING PROGRAM DIMENSION
C                STATEMENT;
C
C      M         NUMBER OF CONTROLS ;
C
C      A         N BY N SYSTEM MATRIX;
C
C      B         N BY M BY KCON SET OF OUTPUT MATRICES ;
C
C      C         IR BY N OUTPUT MATRIX;
C
C      G         M BY N BY KCON SET OF FEEDBACK MATRICES;
C
C      X0        INITIAL CONDITION VECTOR OF LENGTH N ;
C
C      MCON      VECTOR OF LENGTH NPOINT CONTAINING THE EXACT
C                CONFIGURATION INDICES;
C
C      E         SCRATCH VECTOR OF LENGTH KCON ;
C
C      ETEMP     SCRATCH VECTOR OF LENGTH KCON ;
C
C      WORK      SCRATCH VECTOR OF LENGTH N ;
C
C      Y         VECTOR OF LENGTH N ;
C
C      U         VECTOR OF LENGTH M ;
C
C      V,W,WW,EM N BY N SCRATCH ARRAYS ;
C
C      IPV      SCRATCH VECTOR OF LENGTH N ;
C
C      ARRAY     NAR BY NAC WORKING ARRAY;
C                NAR MUST BE GREATER THAN OR EQUAL TO NSTEES + 1
C                NAC MUST BE GREATER THAN OR EQUAL TO IR + M ;
C
C      DT        STEP SIZE;
C
C      NPOINT    NUMBER OF STEPS + 1;
C
C      NGRIDH    NUMBER OF MAJOR ORDINATE DIVISIONS USED
C                IN PLOTTING
C                NGRIDH MUST BE LESS THAN OR EQUAL TO 12;
C
C      *****NOTES:
C      BOTH THE OUTPUT AND THE CONTROL  $U(T) = -G(I)*X(T)$  ARE COMPUTED.

```

SWITCH FORTRAN

```

C
C   GGUB IS A RANDOM NUMBER GENERATOR
C
C   UCAIC IS A USER-SUPPLIED, APPLICATION SPECIFIC FUNCTION TO
C   CALCULATE THE CONTROL U.
C
C   *****HISTORY:
C   WRITTEN BY J.A.K. CARRIG (ELEC. SYS. LAB., M.I.T., RM. 35-307,
C   CAMBRIDGE, MA 02139, PH.: (617) - 253-2165), JANUARY 1978.
C   MOST RECENT VERSION: MARCH 22, 1978.
C
C   :::::::::::::::::::::::::::::::::::::::::::::::::::::::::::::::
C
COMMON/INOU/KIN, KOUT
LCON = 1
DATA YSF/10*1.0D0/,IBLANK/4H /
DATA TWOPI/3.1459/
DATA MSC,MAXES,IXY,IEGY,ZERO,MM,NLG,IZERO/1,0,0,1,1.0D0,1,0,0/
DATA IN(1),IN(2),IN(3),IN(4)/4H1 ,4H2 ,4H3 ,4H4 /
DATA IN(5),IN(6),IN(7),IN(8)/4H5 ,4H6 ,4H7 ,4H8 /
DATA IN(9),IN(10),IN(11),IN(12)/4H9 ,4H10 ,4H11 ,4H12 /
DATA IN(13),IN(14),IN(15),IN(16)/4H13 ,4H14 ,4H15 ,4H16 /
DATA IN(17),IN(18),IN(19),IN(20)/4H17 ,4H18 ,4H19 ,4H20 /
DATA IN(21),IN(22),IN(23),IN(24)/4H21 ,4H22 ,4H23 ,4H24 /
DATA IN(25),IN(26),IN(27)/4H25 ,4H Y,4H U/
DATA IT(3,1),IT(4,1),IT(5,1)/4HVERS,4HUS T,4HIME /
DATA IT(6,1),IT(7,1),IT(8,1)/4H ,4H ,4H /
DATA IT(9,1),IT(10,1)/4H ,4H /
IX=35
DO 61 IZ=1,NPOINT
61 MCON(IZ)= MCON(IZ) + 1
TWOPI = 2.0D0*TWOPI
NSTEPS = NPOINT -1
T= 0.0D0
3001 FORMAT(24H EXACT CONFIGURATION = ,I3)
CALL MMUL(NC,N,N,MM,IR,N,C,X0,Y)
CALL MMUL(NA,N,M,MM,M,N,G(1,1,MCON(1)),X0,U)
WRITE(KOUT,1500)
WRITE(KOUT,1200)
WRITE(KOUT,1300)
WRITE(KOUT,1000) T
1001 FORMAT(/,12H GAIN MATRIX)
WRITE(KOUT,1100) (Y(I),I=1,IR)
WRITE(KOUT,1102) (U(I),I=1,M)
C WRITE(KOUT,1001)
.30 ARRAY(1,J)= Y(J)
DO 40 J=1,M
40 ARRAY(1,IR+J)= U(J)
50 DO 100 K=1,NSTEPS

```

SWITCH FORTRAN

```

WRITE (KOUT, 1002) K
IF (N.EQ. 1) GO TO 72
CALL GGUB (IX, 1, R)
WT (2) = TWOPI * R (1)
CALL GGUB (IX, 1, R)
WT (1) = R (1) * DCOS (WT (2))
WT (2) = R (1) * DSIN (WT (2))
GO TO 73
72 CALL GGUB (IX, 1, R)
WT (1) = (R (1) * 2.0D0) - 1.0D0
73 CALL MMUL (NA, N, N, MM, N, N, EM, WT, WORK)
CALL MMUL (NA, N, N, MM, N, M, B (1, 1, MCON (K)), U, ETEMP)
CALL MADD (N, N, N, N, MM, ETEMP, WORK, ETEMP)
CALL MMUL (NA, N, N, MM, N, N, A, X0, WORK)
CALL MADD (N, N, N, N, MM, ETEMP, WORK, X0)
DO 52 KK = 1, KCON
CALL MMUL (NA, N, N, MM, N, M, B (1, 1, KK), U, Y)
CALL MSUB (N, N, N, N, MM, ETEMP, Y, Y)
SUM = 0.0D0
DO 55 IIJ = 1, KCON
55 SUM = SUM + Y (IIJ) * Y (IIJ)
SUM = DSQRT (SUM)
WT (KK) = 0.0D0
56 IF (SUM.LE. 1.0D0) WT (KK) = 1.0D0
52 CONTINUE
CALL FIG (KCON, E, ETEMP, WT, LCON)
881 FORMAT (18H PI (T-1/T-1) = , 4D25.15)
WRITE (KOUT, 881) (E (IO), IO=1, KCON)
CALL MMUL (NA, KCON, KCON, 1, KCON, KCON, P, ETEMP, E)
WRITE (KOUT, 882) (ETEMP (IO), IO=1, KCON)
882 FORMAT (18H PI (T-1/T) = , 4D25.15)
LCONM1 = LCON - 1
WRITE (KOUT, 4001) LCONM1
MCONM1 = MCON (K+1) - 1
WRITE (KOUT, 3001) MCONM1
4001 FORMAT (29H CALCULATED CONFIGURATION = , I3)
1002 FORMAT (/ , 10H TIME STEP, I3)
CALL MMUL (NC, N, N, MM, IR, N, C, X0, Y)
CALL MMUL (NA, N, M, MM, M, N, G (1, 1, LCON), X0, U)
DO 70 II = 1, M
70 U (M) = UCALC (U, EM, B (1, 1, 1), B (1, 1, 2))
T = T + DT
WRITE (KOUT, 1100) (Y (I), I=1, IR)
WRITE (KOUT, 1102) (U (I), I=1, M)
DO 80 J = 1, IR
80 ARRAY (1+K, J) = Y (J)
DO 90 J = 1, M
90 ARRAY (1+K, IR+J) = U (J)
100 CONTINUE

```

SWITCH FORTRAN

```

XMAX = DFLOAT(NSTEPS)*DT
IW= KOUT
NSYM(1)= 25
IT(1,1)= IN(26)
DO 110 J=1,IR
    IF(J.LE.25) IT(2,1)= IN(J)
    IF(J.GT.25) IT(2,1)= IBIANK
110  CALL THPLT(IW,IEGY,NPOINT,ZERO,XMAX,NGRIDH,MIN,MAX,YSF,IT,
1  ARRAY(1,J),NAR,NLG,MSC,MAXES,IXY,NSYM)
    IT(1,1)= IN(27)
    NSYM(1) = 21
    DO 120 J=1,M
        IF(J.LE.25) IT(2,1)= IN(J)
        IF(J.GT.25) IT(2,1)= IBIANK
120  CALL THPLT(IW,IEGY,NPOINT,ZERO,XMAX,NGRIDH,MIN,MAX,YSF,IT,
1  ARRAY(1,J+IR),NAR,NLG,MSC,MAXES,IXY,NSYM)
1100  FORMAT(4H Y = ,5(2X,1PD19.8))
1000  FORMAT(5H T = ,F5.2)
1102  FORMAT(4H U = ,5(2X,1PD19.8))
1200  FORMAT(11H  OUTPUT Y)
1300  FORMAT(12H  CONTROL U)
1400  FORMAT(/,28H SIMULATION OF LINEAR SYSTEM,/)
1500  FORMAT(/,31H SIMULATION OF LINEAR REGULATOR,/)
RETURN
END

```

ORIGINAL PAGE IS
OF POOR QUALITY

READY FORTRAN

SUBROUTINE READY (NAA, NA, NB, NQ, NR, NG, NS, NRA, N, M, KCON, A, B, R, Q, P,
IWR, WI, S, SB, U, V, W, X, Y, GNORM, RAD, RADINV, BSB, WORK, IPVT, IEND, NSTEPS)

C
C

*****PARAMETERS:

INTEGER NAA, NA, NB, NQ, NR, NG, NS, NRA, N, M, KCON, IPVT (N)
DOUBLE PRECISION A (NA, N), X (NA, N), Q (NQ, N), R (NR, M)
DOUBLE PRECISION S (NS, NAA, KCON), P (NA, KCON), SB (NS, NAA, KCON)
DOUBLE PRECISION GNORM (NG, NAA, KCON), BSB (NB, NAA, KCON), WR (N), WI (N)
DOUBLE PRECISION B (NB, NAA, KCON), RAD (NRA, N), RADINV (NRA, N)
DOUBLE PRECISION U (NA, N), V (NA, N), W (NA, N), Y (NA, N), WORK (N)

C
C

*****LOCAL VARIABLES:

DOUBLE PRECISION COND
INTEGER KIN, KOUT, KL, KM1, J, I, K, JEND, NEND, L, IM1

C
C

*****SUBROUTINES CALLED:

MCQ, MADD, MLINEQ, TRNATB, MMUL, MSCALE, EIGVAL, SAVE, WEIGHT

C
C

.....

C
C

*****PURPOSE:

THIS DOUBLE PRECISION SUBROUTINE SOLVES THE SWITCHING-GAIN PROBLEM
RELATING TO THE PUBLICATION: 'ON THE RELATIONSHIP BETWEEN
RELIABILITY AND LINEAR QUADRATIC OPTIMAL CONTROL'
BY J. DOUGLAS BIRDWELL AND M. ATHANS.

C
C

*****PARAMETER DESCRIPTION:

ON INPUT:

C
C

NAA THE SECOND DIMENSION OF THE ARRAYS S, SB, GNORM,
BSB, B AS DECLARED IN THE CALLING PROGRAM
DIMENSION STATEMENT;

C
C

NA, NB, NQ, NR, THE FIRST DIMENSION OF THE ARRAYS
NG, NS, NRA A (AND P, X, U, V, W, Y), B (AND BSB), Q, R, GNORM,
S (AND SB), RAD (AND RADINV) RESPECTIVELY
AS DECLARED IN THE CALLING PROGRAM DIMENSION
STATEMENT;

C
C

N THE NUMBER OF STATES;

C
C

M THE NUMBER OF OBSERVATIONS;

C
C

KCON THE NUMBER OF CONFIGURATIONS;

C
C

A N BY N SYSTEM MATRIX;

C
C

B N BY M BY KCON SET OF INPUT MATRICES;

C
C

R M BY M CONTROL WEIGHTING MATRIX;

C

READY FORTRAN

```

C
C      Q          N BY N STATE WEIGHTING MATRIX;
C
C      P          KCON BY KCON PROBABILITY MATRIX;
C
C      ON OUTPUT:
C      WR,WI      SCRATCH VECTORS OF LENGTH N;
C
C      S          N BY N BY KCON SET OF SOLUTIONS;
C
C      SB,B,BSB   N BY N BY KCON SCRATCH ARRAYS;
C
C      U,V,W,X,Y  N BY N SCRATCH ARRAYS;
C
C      GNORM      N BY M BY KCON ARRAY USED TO STORE THE
C                  GAIN MATRICES FOR THE NORMAL LINEAR QUADRATIC
C                  GAUSSIAN PROBLEM. ON RETURN, GNORM CONTAINS THE
C                  GAINS ASSOCIATED WITH THE SWITCHING GAIN PROBLEM;
C
C      RAD,RADINV N BY N SCRATCH ARRAYS;
C
C      WORK       SCRATCH VECTOR OF LENGTH N;
C
C      IPVT       SCRATCH VECTOR OF LENGTH N;
C
C      IEND       NUMBER OF ITERATIONS USED IN SOLVING THE NORMAL
C                  LINEAR QUADRATIC GAUSSIAN PROBLEM;
C
C      NSTEPS     NUMBER OF TIME STEPS USED IN COMPUTING S

```

ORIGINAL PAGE IS
OF POOR QUALITY

*****NOTES:

THE SOLUTIONS TO THE NORMAL LINEAR QUADRATIC PROBLEM,
THE EIGENVALUES OF THE MATRICES $(A + B(I)*GNORM(ERO))$
AS WELL AS THE EIGENVALUES OF THE MATRICES $(A + B(I)*G(I))$
ARE PRINTED.

*****HISTORY:

WRITTEN BY J.A.K. CARRIG (ELEC. SYS. LAB., M.I.T., RM. 35-307,
CAMBRIDGE, MA 02139, PH.: (617) - 253-2165), JANUARY 1978.
MOST RECENT VERSION: MARCH 22, 1978.

.....

```

COMMON/INOU/KIN, KOUT
WRITE (KOUT, 9600)
CALL MATIO (NA, N, N, A, 3)
WRITE (KOUT, 9700)

```

READY FORTRAN

```

CALL MATIO (NA, N, N, Q, 3)
WRITE (KOUT, 9800)
CALL MATIO (NR, N, N, R, 3)
DO 222 KL=1, KCON
  KM1 = KL-1
  WRITE (KOUT, 9900) KM1
  CALL MATIO (NB, N, M, B(1, 1, KL), 3)
  DO 4 J=1, N
    DO 3 I=1, N
3     Y(I, J) = 0.000
4     Y(J, J) = 1.000
  DO 210 K=1, IEND
    CALL MCF (NA, NB, NA, N, M, Y, B(1, 1, KL), U, WORK)
    CALL MADD (NA, NR, NA, M, M, U, R, U)
    DO 14 J=1, M
      DO 13 I=1, M
13     V(I, J) = 0.000
14     V(J, J) = 1.000
    CALL MLINEQ (NA, NA, M, M, U, V, COND, IPVT, WORK)
    CALL TRNATB (NB, NA, N, M, B(1, 1, KL), X)
    CALL MMUL (NA, NA, NA, N, M, N, X, Y, U)
    CALL MMUL (NA, NA, NA, N, M, N, U, A, X)
    CALL MCF (NA, NA, NA, M, N, V, X, W, WORK)
    CALL MSCALE (NA, N, N, -1.000, W)
    CALL MCF (NA, NA, NA, N, N, Y, A, U, WORK)
    CALL MADD (NA, NA, NA, N, N, U, Q, U)
    CALL MADD (NA, NA, NA, N, N, U, W, Y)
210  CONTINUE
    WRITE (KOUT, 44441)
    WRITE (KOUT, 44442)
    CALL MATIO (NA, N, N, Y, 3)
    CALL MMUL (NA, NA, NG, N, M, M, V, X, GNORM(1, 1, KL))
    CALL MSCALE (NA, M, N, -1.000, GNORM(1, 1, KL))
    WRITE (KOUT, 6000)
    CALL MATIO (NG, M, N, GNORM(1, 1, KL), 3)
    CALL MMUL (NB, NG, NA, N, N, M, B(1, 1, KL), GNORM(1, 1, 1), V)
    CALL MADD (NA, NA, NA, N, N, V, A, V)
    WRITE (KOUT, 7000)
    CALL EIGVAL (NA, N, V, V, WR, WI, WORK, IPVT)
222  CONTINUE
    JEND = 1
26  CONTINUE
    WRITE (KOUT, 8000)
    CALL MATIO (NA, KCON, KCON, P, 3)
    DO 5 K=1, KCON
      CALL SAVE (NQ, NS, N, N, Q, S(1, 1, K))
5  CONTINUE
    DO 91 NEND = 1, NSTEPS
      WRITE (KOUT, 4500) NEND

```

READY FORTRAN

```

200  CONTINUE
      DO 90 L=1, KCON
        DO 80 K=1, KCON
          CALL MQF (NS, NB, NB, N, M, S(1, 1, K), B(1, 1, K), BSB(1, 1, K), WORK)
          CALL MMUL (NS, NB, NS, M, N, N, S(1, 1, K), B(1, 1, K), SB(1, 1, K))
80    CONTINUE
      CALL WEIGHT (NS, NAA, KCON, NA, N, M, P(1, L), SB, V)
      CALL WEIGHT (NS, NAA, KCON, NA, M, M, P(1, L), BSB, RAD)
      CALL MADD (NR, NRA, NA, M, M, R, RAD, U)
      DO 98 J=1, M
        DO 97 I=1, M
97          RADINV(I, J) = 0.000
98          RADINV(J, J) = 1.000
          CALL MLINEQ (NA, NRA, M, M, U, RADINV, COND, IPVT, WORK)
          DO 70 K=1, KCON
            DO 60 J=1, N
              DO 60 I=1, M
60                BSB(I, J, K) = SB(J, I, K)
70            CONTINUE
          CALL WEIGHT (NS, NAA, KCON, NA, M, N, P(1, L), BSB, U)
          CALL MMUL (NRA, NA, NA, N, M, M, RADINV, U, W)
          CALL MMUL (NA, NA, NA, N, N, M, V, W, Y)
          CALL MMUL (NA, NA, NG, N, M, N, W, A, GNORM(1, 1, L))
          CALL MSCALE (NG, M, N, -1.000, GNORM(1, 1, L))
          LM1 = L-1
          WRITE (KOUT, 2005) LM1
          CALL MATIO (NG, M, N, GNORM(1, 1, L), 3)
          IF (NEND.NE.NSTEPS) GO TO 73
          CALL MMUL (NB, NG, NA, N, N, M, B(1, 1, L), GNORM(1, 1, L), W)
          CALL MADD (NA, NA, NA, N, N, A, W, W)
          WRITE (KOUT, 7009) LM1, LM1
          CALL EIGVAL (NA, N, W, W, WR, WI, WORK, IPVT)
73        CALL MSCALE (NA, N, N, -1.000, Y)
          CALL WEIGHT (NA, NAA, KCON, NA, N, N, P(1, L), S, W)
          CALL MADD (NA, NA, NA, N, N, W, Y, Y)
          CALL MQF (NA, NA, NA, N, N, Y, A, W, WORK)
          CALL MADD (NA, NA, NS, N, N, W, Q, S(1, 1, L))
          WRITE (KOUT, 4000) LM1
          CALL MATIO (NS, N, N, S(1, 1, L), 3)
90      CONTINUE
91    CONTINUE
2000  FORMAT (3D25.15)
4005  FORMAT (3H S)
2005  FORMAT (4H G, I3)
4000  FORMAT (4H S, I3)
4500  FORMAT (11H TIME= T2 -, I3)
5000  FORMAT (11H ITERATION , I3)
6000  FORMAT (10H G OPTIMAL )
7000  FORMAT (40H OPTIMAL COST FUNCTION X C X, WHERE C IS)

```

ORIGINAL PAGE IS
OF POOR QUALITY

READY FORTRAN

```
7008 FORMAT (21H A + B(I)*GSTAR(ZERO))
7009 FORMAT (7H A + B, I3, 5H * G, I3)
8000 FORMAT (3H P)
9500 FORMAT (3D.25..15)
9700 FORMAT (3H Q)
9600 FORMAT (3H A)
9800 FORMAT (3H R)
9900 FORMAT (3H B, I3)
44441 FORMAT (/ , 45H SOLUTION TO STANDARD OPTIMAL CONTROL PROBLEM)
2 STOP
44442 FORMAT (3H S )
RETURN
END
```

WEIGHT FORTRAN

```

SUBROUTINE WEIGHT (NA, NAA, KCON, NX, N, M, E, A, X)
C
C *****PARAMETERS:
C   INTEGER NA, NAA, KCON, NX, N, M
C   DOUBLE PRECISION E (KCON), A (NA, NAA, KCON), X (NX, M)
C
C *****LOCAL VARIABLES:
C   INTEGER I, J, K
C   DOUBLE PRECISION SUM
C
C *****SUBROUTINES CALLED:
C   NONE
C
C *****PURPOSE:
C   THIS SUBROUTINE COMPUTES THE WEIGHTED SUM
C
C   SUMMATION E (I)*A(I, J, K); I=1, N; J=1, M; K=1, KCON.
C
C *****PARAMETER DESCRIPTION:
C   NA      THE FIRST DIMENSION OF THE ARRAY A AS DECLARED IN
C           THE CALLING PROGRAM DIMENSION STATEMENT;
C
C   NAA     THE SECOND DIMENSION OF THE ARRAY AS DECLARED IN
C           THE CALLING PROGRAM DIMENSION STATEMENT;
C
C   KCON    THE THIRD DIMENSION OF THE ARRAY A AS DECLARED IN
C           THE CALLING PROGRAM DIMENSION STATEMENT;
C
C   NX      THE FIRST DIMENSION OF THE ARRAY X AS DECLARED IN
C           CALLING PROGRAM DIMENSION STATEMENT;
C
C   N       THE ROW SIZE OF A;
C
C   M       THE COLUMN SIZE OF A;
C
C   E       VECTOR OF LENGTH KCON;
C
C   A       N BY; M ARRAY
C
C *****HISTORY:
C   WRITTEN BY J.A.K. CARRIG (ELEC. SYS. LAB., M.I.T., RM. 35-307,
C   CAMBRIDGE, MA 02139, PH.: (617) - 253-2165), JANUARY 1978.
C   MOST RECENT VERSION MARCH 22, 1978.
C
C   ::::::::::::::::::::::::::::::::::::::::::::::::::::::::::::::
C
C   DO 10 J=1, M
C     DO 10 I=1, N
C       X(I, J) =0.00

```

ORIGINAL PAGE IS
OF POOR QUALITY

WEIGHT FORTRAN

```
      DO 10 K=1, KCON
10      X(I, J) = X(I, J) + E(K)*A(I, J, K)
      RETURN
      END
```

UCALC FORTRAN

```
FUNCTION UCALC(U,EM,B,C)
DOUBLE PRECISION U(10,2),EM(10,2),B(10,2),C(10,2)
RETURN
END
```

ORIGINAL PAGE IS
OF POOR QUALITY

FIG FORTRAN

```

SUBROUTINE FIG (KCON, E, ETEMP, WORK, LCON)
C
C *****PARAMETERS:
DOUBLE PRECISION WORK(KCON), E(KCON), ETEMP(KCON)
C
C *****LOCAL VARIABLES:
INTEGER MM, LTEMP, IFLAG, KK, IP, IU
DOUBLE PRECISION SUM
C
C *****SUBROUTINES CALLED:
NONE
C
C ::::::::::::::::::::::::::::::::::::::::::::::::::::::::::::
C
C *****PURPOSE:
C THIS DOUBLE PRECISION SUBROUTINE IS USED IN HYPOTHESIS TESTING.
C AT EACH TIME T, ONE OF KCON HYPOTHESES IS CHOSEN.
C
C
C          RHO (X (T) - A*X (T-1) - B(I)*U (T-1)) *PI (T-1/T-1)
C                                     I
C
C PI (T-1/T) = 
$$\frac{\text{RHO (X (T) - A*X (T-1) - B(I)*U (T-1)) *PI (T-1/T-1)}_I}{\text{SUM(RHO (X (T) - A*X (T-1) - B(J)*U (T-1)) *PI (T-1/T-1)}_J}$$

C
C
C HYPOTHESIS H (I) IS ASSUMED TO BE CORRECT IF
C
C PI (T/T-1) > PI (T-1/T) FOR ALL J NOT EQUAL I
C       I           J
C
C TIES ARE RESOLVED ARBITRARILY.
C
C RHO (X) DENOTES THE PROBABILITY DISTRIBUTION OF X.
C
C *****PARAMETER DESCRIPTION:
C ON INPUT:
C       KCON           THE NUMBER OF HYPOTHESES ;
C
C       E              VECTOR OF LENGTH KCON CONTAINING PI (T-1/T-1);
C
C       WORK           VECTOR OF LENGTH KCON CONTAINING
C                     RHO (X (T) - A*X (T-1) - B(I)*U (T-1));
C
C ON OUTPUT:
C       ETEMP         VECTOR OF LENGTH KCON TO STORE PI (T/1-1);
C
C       LCON          INDICATES WHICH HYPOTHESIS HAS BEEN CHOSEN;
C
C *****HISTORY:

```

FIG FORTRAN

```

C   WRITTEN BY J.A.K. CARRIG (ELEC. SYS. LAB., M.I.T., RM. 35-307,
C   CAMBRIDGE, MA 02139, PH.: (617) - 253-2165), JANUARY 1978.
C   MOST RECENT VERSION MARCH 22, 1978.
C
C   ::::::::::::::::::::::::::::::::::::::::::::::::::::::::::::::::::::
C
COMMON/INOU/KIN, KOUT
MM = 1
LTEMP = LCON
SUM = 0.000
DO 10 IP = 1, KCON
10  SUM = SUM + WORK(IP)*E(IP)
DO 20 IP=1, KCON
20  ETEMP(IP) = WORK(IP)*E(IP)/SUM
DO 60 KK = 1, KCON
  IFIAG = 0
  DO 89 IU= 1, KCON
    IF(KK.EQ.IU) GO TO 79
    IF(ETEMP(KK).GT.E(IU)) IFIAG = IFIAG + 1
79  CONTINUE
89  CONTINUE
  IFIAG = IFIAG + 1
  IF (IFIAG.EQ.KCON) LCON= KK
60 CONTINUE
  IF (LCON.EQ.0) LCON = LTEMP
RETURN
END

```

ORIGINAL PAGE IS
OF POOR QUALITY

RDYMAIN FORTRAN

C LATEST VERSION 3/9/77

```

DOUBLE PRECISION COND,BEE,WR(10),WI(10)
DOUBLE PRECISION A(10,3),X(10,3)
INTEGER MDOMYR(2),HRMNSC(2),VTIME(2),RTIME(2)
DOUBLE PRECISION GNORM(10,3,4)
DOUBLE PRECISION BSB(10,3,4)
DOUBLE PRECISION S(10,3,4),P(10,4),SB(10,3,4)
DOUBLE PRECISION SBT(10,3),Q(10,3),R(10,3),B(10,3,4)
DOUBLE PRECISION PR(4),P1,P2,PZ(4),PD(10,4),PS(4)
INTEGER IPVTF(10)
DOUBLE PRECISION AZERO,ACONE,ATWO
DOUBLE PRECISION RAD(10,3),RADINV(10,3),U(10,3)
DOUBLE PRECISION V(10,3),W(10,3),Y(10,3),SUM,WORK(10)
COMMON/INOUI/KIN,KOUT
NAA= 3
ATWO= -3.0D0
AZERO = -4.0D0
ACONE = 6.0D0
P1= .05D0
P2 = .75D0
KIN= 5
KOUT= 6
N= 3
M= 3
N2 = 6
KCON = 3
NS= 10
IPRT= 17
IEND= 25
ICOUNT = 0
NSTEPS = 25
NA= 10
NM=NA
NRA= 10
NR= 10
NB= 10
NQ= 10
NG=10
22 IF (ICOUNT.NE.0) READ (KIN, 9500, END=2) (PR(I),PZ(I),I=1,N)
9500 FORMAT (3D25.15)
DO 11 JK= 1,N
DO 11 JL = 1,N
Q(JL,JK) = 0.0D0
R(JK,JL) = 0.0D0
11 A(JL,JK) = 0.0D0
BEE = -10.0D0
P(1,1) = 1.0D0-P1
P(2,2) = 1.0D0- P2
P(3,3) = 1.0D0

```

RDYMAIN FORTRAN

```

P(1,2) = 0.000
P(1,3) = 0.000
P(2,1) = P1
P(2,3) = 0.000
P(3,1) = 0.000
P(3,2) = P2
A(1,1) = 0.000
A(2,2) = 0.000
A(3,3) = -AZERO
A(1,2) = 1.000
A(2,3) = 1.000
A(3,1) = -ATWO
A(3,2) = -AONE
Q(1,1) = 3.000
Q(2,2) = 3.000
Q(3,3) = 3.000
R(1,1) = 1.000
R(2,2) = 1.000
R(3,3) = 1.000
B(1,1,1) = 00.000
B(2,2,1) = 0.000
B(2,1,1) = 0.000
B(1,2,1) = 0.000
B(1,3,1) = 0.000
B(2,3,1) = 0.000
B(3,3,1) = 1.000
B(3,1,1) = 1.000
B(3,2,1) = 1.000
B(1,1,2) = 0.000
B(2,2,2) = 0.000
B(2,1,2) = 0.000
B(1,2,2) = 0.000
B(1,3,2) = 0.000
B(2,3,2) = 0.000
B(3,3,2) = BEE
B(3,1,2) = 1.000
B(3,2,2) = 1.000
B(1,1,3) = 0.000
B(2,2,3) = 0.000
B(2,1,3) = 0.000
B(1,2,3) = 0.000
B(1,3,3) = 0.000
B(2,3,3) = 0.000
B(3,3,3) = 0.000
B(3,1,3) = 1.000
B(3,2,3) = 1.000
PR(1) = .0500
PR(2) = .7500
P(1,1) = 1.000 - PR(1)

```

ORIGINAL PAGE IS
OF POOR QUALITY

RDYMAIN FORTRAN

```
P (2, 1) = PR (1)
P (3, 1) = 0.0D0
P (1, 2) = 0.0D0
P (1, 3) = 0.0D0
P (2, 2) = 1.0D0 - PR (2)
P (3, 2) = PR (2)
P (2, 3) = 0.0D0
P (3, 3) = 1.0D0
C   CALL TIME (MDOYR, HRMN, SC, VTIME, RTIME)
    CALL READY (NAA, NA, NB, NO, NR, NG, NS, NRA, N, M, KCON, A, B, R, Q, P,
1   WR, WI, S, SB, U, V, W, X, Y, GNORM, RAD, RADINV, BSB, WORK, IPVT, IEND,
2   NSTEPS)
2   STOP
    END
```

SWMAT FORTRAN

C LATEST VERSION 2/17/78

```

DOUBLE PRECISION E(4), ETEMP(4), SUM, SIGMA, SIGM1, ESINV, ESIGMA, SINVM1
DOUBLE PRECISION COND, LUDOLF, LUDINV, DOLEFM1, EM(10, 2), X0(10), DINVM1
DOUBLE PRECISION ARRAY(100, 50), Y0(10), U0(10)
DOUBLE PRECISION A(10, 3), C(10, 3), PR1, PR2, X(10, 3)
E(1) = 1.0D0
      EM(1, 1) = 1.0D0
EM(2, 2) = 1.0D0
E(2) = 0.0D0
ETEMP(2) = E(2)
E(3) = 0.0D0
ETEMP(3) = E(3)
ETEMP(1) = E(1)
E(4) = 0.0D0
DOUBLE PRECISION GNORM(10, 2, 4)
DOUBLE PRECISION BSB(10, 4, 3)
DOUBLE PRECISION S(10, 3, 4), DE, P(10, 4), SB(10, 3, 4)
DOUBLE PRECISION WR(4), WI(4), HH(4, 4), XX(4, 4), ACL(10, 3)
DOUBLE PRECISION SBT(10, 3), Q(10, 3), R(10, 3), B(10, 2, 4)
DOUBLE PRECISION PR(4), PZ(4), PD(10, 4), PS(4)
INTEGER IPVT(10), MCON(100), NSTEPS, NGRIDH, ICON(100)
DOUBLE PRECISION RAD(10, 3), RADINV(10, 3), SNEW(10, 3, 4), U(10, 3)
DOUBLE PRECISION V(10, 3), WV(10, 3), W(10, 3), Y(10, 3), SUM, WORK(10)
LOGICAL NOISE
COMMON/INOU/KIN, KOUT
K0=0
IA = 1
READ(5, 11111) NPOINT
33333 READ(5, 11111, END=22222) ITIME, K
11111 FORMAT(2I4)
      DO 44444 IXYZ = IA, ITIME
44444 MCON(IXYZ) = K0
      MCON(ITIME)= K
      IA = ITIME
      K0= K
      GO TO 33333
22222 DO 55555 IXYZ = ITIME, NPOINT
55555 MCON(IXYZ) = K0
      LUDOLF= 2.718281828459045D0
      LUDINV= 1.0D0/LUDOLF
      DOLEFM1 = LUDOLF - 1.0D0
      DINVM1 = LUDINV - 1.0D0
      NAA = 2
      NC = 10
      KIN= 5
      KOUT= 6
      N= 2
      M= 2
      N2 = 4

```

ORIGINAL PAGE IS
OF POOR QUALITY

SWMAT FORTRAN

```

KCON = 4
NH= 4
NS= 10
IPRT= 17
IEND= 50
IPRT = 49
ICOUNT = 0
NA= 10
NB= 10
NM=NA
NRA= 10
NR= 10
NQ= 10
NG=10
PZ(1) = .1D0
PR(1)= .1D0
DO 15 I=2,N
PR(I)= PR(1)
15 PZ(I)= PZ(1)
22 IF(ICOUNT.NE.0) READ(KIN,9500,END=2) (PR(I),PZ(I),I=1,N)
SIGMA= 1.0D0
ESIGMA= LUDOLF**SIGMA
ESINV= LUDINV**SIGMA
C(1,1) = 1.0D0
C(2,2) = 1.0D0
C(1,2) = 0.0D0
C(2,1) = 0.0D0
DT = 1.0D0
NSTEPS = 50
A(1,1)= ESIGMA
NAR= 100
NAC = 50
A(2,2)= ESINV
A(2,1) = 0.0D0
A(1,2) =0.0D0
Q(1,1)= 14.0D0
Q(2,1)= 8.0D0
Q(1,2) = 8.0D0
Q(2,2) = 6.0D0
R(1,1)= 1.0D0
R(2,1) = 0.0D0
R(1,2) = 0.0D0
R(2,2) = 1.0D0
B(1,1,1)= ESIGMA -1.0D0
B(2,1,1)= ESINV- 1.0D0
B(2,2,1) = -B(2,1,1)
B(1,2,1)= B(1,1,1)
B(1,1,2) = 0.0D0
B(2,2,2) = -DINVM1

```

SWMAT FORTRAN

```

B(2, 1, 2)= 0.000
B(1, 2, 2) = DOLEFM1
B(1, 1, 3) = DOLEFM1
B(1, 2, 3) = 0.000
B(2, 1, 3) = DINVM1
B(2, 2, 3) = 0.000
PR1 = .1D0
PR2= .1D0
P(1, 1) = .81D0
P(2, 2) = .09D0
P(3, 2) = 0.09D0
P(3, 3) = .09D0
P(1, 2) = .81D0
P(3, 1) = .09D0
P(2, 1) = .09D0
P(1, 3) = .81D0
P(2, 3) = 0.09D0
P(4, 1) = .01D0
P(1, 4) = .81D0
P(4, 2) = .01D0
P(4, 3) = .01D0
P(4, 4) = .01D0
P(2, 4) = .09D0
P(3, 4) = .09D0
WRITE (KOUT, 9903)
CALL MATIO (NA, KCON, KCON, P, 3)
C WRITE (KOUT, 46)
46 FORMAT (/ , 4H PI, /)
47 FORMAT (3D25.15)
WRITE (KOUT, 9600)
CALL MATIO (NA, N, N, A, 3)
WRITE (KOUT, 9700)
CALL MATIO (NA, N, N, Q, 3)
WRITE (KOUT, 9800)
CALL MATIO (NR, N, N, R, 3)
DO 222 K=1, KCON
  KM1 = K-1
  WRITE (KOUT, 9900) KM1
222 WRITE (KOUT, 9500) ((B(I, J, K), J=1, M), I=1, N)
44 CONTINUE
  DO 14 IN=1, 50
    LCON (IN) = LCON (1)
14 CONTINUE
667 FORMAT (5I5)
X0(1) = .02D0
GNORM(1, 1, 1)= -1.06336184D0
GNORM(2, 1, 1)= -7.9015188D-1
GNORM(1, 2, 1)= -1.88787889D-02
GNORM(2, 2, 1)= -5.83582496D-02

```

ORIGINAL PAGE IS
OF POOR QUALITY

SWMAT FORTRAN

```

GNORM(1,1,2)= -3.69012096D-01
GNORM(2,1,2)= -1.14016534D0
GNORM(1,2,2)= 1.04948339D-01
GNORM(2,2,2)= -1.36308767D=01
GNORM(1,1,3)= -1.42566767D0
GNORM(2,1,3)= -2.87451308D-01
GNORM(1,2,3)= 1.51884285D-02
GNORM(2,2,3)= -7.27012438D-02
IR = 2
NPRPL = 1
DO 57 IK = 1, KCON
  IKM1 = IK - 1
  WRITE (KOUT, 9902) IKM1
57  WRITE (KOUT, 9500) ((GNORM(IJ, IL, IK), IL=1, N), IJ=1, N)
  NGRIDH = 5
  V(1,1) = B(1,1,1)
  V(2,2) = B(2,2,1)
  V(2,1) = B(2,1,1)
  V(1,2) = B(1,2,1)
C   CALL MMUL (NA, NA, NA, N, N, M, V, GNORM, U)
C   CALL MADD (NA, NA, NA, N, N, U, A, ACL)
C   CALL MSCALE (NG, N, M, -1.0D0, GNORM)
  IONE = 1
C   CALL MMUL (NC, N, N, IONE, IR, N, C, X0, Y0)
65  FORMAT (1X, 3D25.15)
C   CALL DRGSIM (NA, NC, NG, NAR, NAC, N, IR, M, ACL, C, GNORM, X0, WORK,
C   LY, U, IPVT, ARRAY, DT, NSTEPS, NPRPL)
C   CALL READY2 (NAA, NA, NB, NQ, NR, NG, NS, NRA, N, M, KCON, A, B, R, Q, P,
C   1 WR, WI, S, SB, U, V, W, X, Y, GNORM, RAD, RADINV, BSB, WORK, IPVT, IEND)
  DT = 1.0D0
  X0(1) = .02D0
C   CALL MSCALE (NG, N, M, -1.0D0, GNORM)
  X0(2) = 0.0D0
  CALL SWITCH (NA, NB, NC, NG, NAR, NAC, N, IR, NAA, KCON, M, A, B, P,
  1 C, GNORM, X0, E, ETEMP, EM, WORK, Y0, U0, V, W, W, IPVT, ARRAY, DT, NSTEPS,
  2 NGRIDH, MCON)
9500 FORMAT (2D25.15)
2000 FORMAT (/ , 3D25.15)
9600 FORMAT (/ , 3H A )
9700 FORMAT (/ , 3H Q )
9800 FORMAT (/ , 3H R )
9900 FORMAT (/ , 3H B , I5, /)
9903 FORMAT (/ , 3H P )
9902 FORMAT (/ , 3H G , I5, /)
2  STOP
END

```

SWMAT2 FORTRAN

C LATEST VERSION 2/17/78

```

DOUBLE PRECISION E(4), ETEMP(4), SUM, SIGMA, SIGM1, ESINV, ESIGMA, SINVM1
DOUBLE PRECISION COND, LUDOLF, LUDINV, DOLEFM1, EM(10, 2), X0(10), DINVM1
DOUBLE PRECISION ARRAY(100, 50), Y0(10), U0(10)
DOUBLE PRECISION A(10, 3), C(10, 3), PR1, PR2, X(10, 3)
E(1) = 1.0D0
EM(1, 1) = 1.0D0
EM(2, 2) = 1.0D0
E(2) = 0.0D0
ETEMP(2) = E(2)
E(3) = 0.0D0
ETEMP(3) = E(3)
ETEMP(1) = E(1)
E(4) = 0.0D0
DOUBLE PRECISION GNORM(10, 2, 4)
DOUBLE PRECISION BSB(10, 4, 3)
DOUBLE PRECISION S(10, 3, 4), DT, P(10, 4), SB(10, 3, 4)
DOUBLE PRECISION WR(4), WI(4), HH(4, 4), XX(4, 4), ACL(10, 3)
DOUBLE PRECISION SBT(10, 3), Q(10, 3), R(10, 3), B(10, 2, 4)
DOUBLE PRECISION PR(4), PZ(4), PD(10, 4), PS(4)
INTEGER IPVF(10), MCON(100), NPOINT, NGRIDH, ICON(100)
DOUBLE PRECISION RAD(10, 3), RADINV(10, 3), SNEW(10, 3, 4), U(10, 3)
DOUBLE PRECISION V(10, 3), W(10, 3), W(10, 3), Y(10, 3), SUM, WORK(10)
LOGICAL NOISE
COMMON/INOU/KIN, KOUT
K0=0
IA = 1
READ(5, 11111)NPOINT
33333 READ(5, 11111, END=22222)ITIME, K
11111 FORMAT(2I4)
DO 44444 IXYZ = IA, ITIME
44444 MCON (IXYZ) = K0
MCON (ITIME) = K
IA = ITIME
K0 = K
GO TO 33333
22222 DO 55555 IXYZ = ITIME, NPOINT
55555 MCON (IXYZ) = K0
LUDOLF = 2.718281828459045D0
LUDINV = 1.0D0/LUDOLF
DOLEFM1 = LUDOLF - 1.0D0
DINVM1 = LUDINV - 1.0D0
NAA = 2
NC = 10
KIN = 5
KOUT = 6
N = 1
M = 1
N2 = 2

```

ORIGINAL PAGE IS
OF POOR QUALITY

SWMAT2 FORTRAN

```

      KCON = 2
      NH= 4
      NS= 10
      IPRT= 17
      IEND= 50
      IPRT = 49
      ICOUNT = 0
      NA= 10
      NB= 10
      NM=NA
      NRA= 10
      NR= 10
      NQ= 10
      NG=10
      PZ(1) = .1D0
      PR(1)= .1D0
      DO 15 I=2,N
      PR(I)= PR(1)
15  PZ(I)= PZ(1)
22  IF(ICOUNT.NE.0) READ(KIN,9500,END=2) (PR(I),PZ(I),I=1,N)
      SIGMA= 1.0D0
      ESIGMA= LUDOLF**SIGMA
      ESINV= LUDINV**SIGMA
      C(1,1) = 1.0D0
      C(2,2) = 1.0D0
      C(1,2) = 0.0D0
      C(2,1) = 0.0D0
      DT = 1.0D0
      A(1,1)= 1.4140D0
      NAR= 100
      NAC = 50
      Q(1,1) = 3.0D0
      R(1,1)= 1.0D0
      R(2,1) = 0.0D0
      B(1,1,1)= 2.0D0
      B(1,1,2)= .5D0
      P(1,1) = .7D0
      P(2,2) = .7D0
      P(3,2) = 0.09D0
      P(3,3) = .09D0
      P(1,2) = .3D0
      P(3,1) = .09D0
      P(2,1) = .3D0
      P(1,3) = .81D0
      P(2,3) = 0.09D0
      P(4,1) = .01D0
      P(1,4) = .81D0
      P(4,2) = .01D0
      P(4,3) = .01D0

```

SWMAT2 FORTRAN

```

P(4,4) = .01D0
P(2,4) = .09D0
P(3,4) = .09D0
WRITE (KOUT,9903)
CALL MATIO (NA, KCON, KCON, P, 3)
C
46 FORMAT (/ ,4H PI, /)
47 FORMAT (3D25.15)
WRITE (KOUT,9600)
CALL MATIO (NA, N, N, A, 3)
WRITE (KOUT,9700)
CALL MATIO (NA, N, N, Q, 3)
WRITE (KOUT,9800)
CALL MATIO (NR, N, N, R, 3)
DO 222 K=1, KCON
  KM1 = K-1
  WRITE (KOUT,9900) KM1
222 WRITE (KOUT,9500) ((B(I, J, K), J=1, M), I=1, N)
44 CONTINUE
  GNORM(1,1,1) = -1.06336184D0
  GNORM(1,2,1) = -1.88787889D-02
  GNORM(2,1,1) = 7.90151884D-01
  GNORM(2,2,1) = -5.8358246D-02
  GNORM(1,1,2) = -3.69012096D-01
  GNORM(1,2,2)=1.04948339D-01
  GNORM(2,1,2) = -1.14016354D0
  GNORM(2,2,2) = -1.36308767D-01
  GNORM(1,1,3)= -1.42566767D0
  GNORM(2,1,3)= -2.87451308D-01
  GNORM(2,2,3) = -7.27012438-02
  GNORM(1,2,3) = 1.51884285D-02
  GNORM(1,1,4) = 0.0D0
  GNORM(2,2,4) = 0.0D0
  GNORM(1,2,4) = 0.0D0
  GNORM(1,2,4) = 0.0D0
  DO 14 IN=1, 50
    LCON(IN) = LCON(1)
14 CONTINUE
667 FORMAT (5I5)
X0(1) = .02D0
IR = 1
NPRPL = 1
DO 57 IK = 1, KCON
  IKM1 = IK - 1
  WRITE (KOUT,9902) IKM1
57 WRITE (KOUT,9500) ((GNORM(IJ, IL, IK), IL=1, N), IJ=1, N)
  NGRIDH = 5
  V(1,1) = B(1,1,1)
  V(2,2) = B(2,2,1)

```

ORIGINAL PAGE IS
OF POOR QUALITY

SWMAT2 FORTRAN

```

      V(2,1) = B(2,1,1)
      V(1,2) = B(1,2,1)
C      CALL MMUL (NA, NA, NA, N, N, M, V, GNORM, U)
C      CALL MADD (NA, NA, NA, N, N, U, A, ACL)
C      CALL MSCALE (NG, N, M, -1.0D0, GNORM)
      IONE = 1
C      CALL MMUL (NC, N, N, IONE, IR, N, C, X0, Y0)
66  FORMAT (1X, 3D25.15)
C      CALL DRGIM (NA, NC, NG, NAR, NAC, N, IR, M, ACL, C, GNORM, X0, WORK,
C      LY, U, IPVT, ARRAY, DT, NPOINT, NPRPL)
C      CALL READY2 (NAA, NA, NB, NQ, NR, NG, NS, NRA, N, M, KCON, A, B, R, Q, P,
C      1 WR, WI, S, SB, U, V, W, X, Y, GNORM, PAD, RADINV, BSB, WORK, IPVT, IEND)
      DT = 1.0D0
      X0(1) = .02D0
C      CALL MSCALE (NG, N, M, -1.0D0, GNORM)
      X0(2) = 0.0D0
      CALL SWITCH (NA, NB, NC, NG, NAR, NAC, N, IR, NAA, KCON, M, A, B, P,
1 C, GNORM, X0, E, ETEMP, EM, WORK, Y0, U0, V, W, VW, IPVT, ARRAY, DT, NPOINT,
2 NGRIDH, MCON)
9500 FORMAT (2D25.15)
2000 FORMAT (/, 3D25.15)
9600 FORMAT (/, 3H A )
9700 FORMAT (/, 3H Q )
9800 FORMAT (/, 3H R )
9900 FORMAT (/, 3H B , I5, /)
9903 FORMAT (/, 3H P )
9902 FORMAT (/, 3H G , I5, /)
2  STOP
   END

```

LIST OF REFERENCES

- [1] Shooman, Martin L., Probabilistic Reliability: An Engineering Approach. New York: McGraw-Hill, 1968.
- [2] Greene, A.E. and Bourne, A.J., Reliability Technology. London: Wiley-Interscience, 1972.
- [3] Paz, Azaria, Introduction to Probabilistic Automata. New York: Academic Press, 1971.
- [4] Fel'dbaum, A.A., "Dual-Control Theory. I," Automation and Remote Control, vol. 21, no. 9, pp. 874-880, April 1961.
- [5] Fel'dbaum, A.A., "Dual Control Theory. II," Automation and Remote Control, vol. 21, no. 11, pp. 1033-1039, May 1961.
- [6] Fel'dbaum, A.A., "The Theory of Dual Control. III," Automation and Remote Control, vol. 22, no. 1, pp. 1-12, Aug. 1961.
- [7] Fel'dbaum, A.A., "The Theory of Dual Control. IV," Automation and Remote Control, vol. 22, no. 2, pp. 109-121, Sept. 1961.
- [8] Rudin, W., Real and Complex Analysis. 2nd ed. New York: McGraw-Hill, 1974.
- [9] Segal, I.E., and Kunze, R.A., Integrals and Operators. New York: McGraw-Hill, 1968.
- [10] Halmos, Paul R., Measure Theory. New York: Springer-Verlag, 1974.
- [11] Gantmacher, F.R., The Theory of Matrices, vols. I & II. New York: Chelsea, 1960.
- [12] Bauer, H., Probability Theory and Elements of Measure Theory. New York: Holt, Rinehart & Winston, 1972.
- [13] Doob, J.L., Stochastic Processes. New York: John Wiley, 1953.
- [14] Chung, Kai Lai, Markov Chains with Stationary Transition Probabilities, 2nd. ed. New York: Springer-Verlag, 1967.
- [15] Derman, Cyrus, Finite State Markovian Decision Processes. New York: Academic Press, 1970.
- [16] Cox, D.R., Renewal Theory. London: Methuen, 1970.

- [17] Corcoran, Henry, "Optimal Policies in Reliability Problems," M.S. Thesis, Dept. of Elec. Engr., M.I.T., Cambridge, Ma, 1964.
- [18] Barlow, R.E. and Proschan, F., Mathematical Theory of Reliability. New York: John Wiley, 1965.
- [19] Gendenko, B.V., Belyayev, Yu. K., Solovjev, A.D., Mathematical Methods of Reliability Theory. New York: Academic Press, 1969.
- [20] Athans, M., ed., Special Issue on the Linear-Quadratic-Gaussian Estimation and Control Problem. IEEE Trans. on Automatic Control, vol. AC-16, no. 6, pp. 527-869, Dec. 1971.
- [21] Athans, M. and Falb, P.L., Optimal Control. New York: McGraw-Hill, 1966.
- [22] Wonham, W.M., "Random Differential Equations in Control Theory," from Probabilistic Methods in Applied Mathematics, vol. II. A.T. Bharucha-Reid, ed. New York: Academic Press, 1970.
- [23] Beard, R.V., "Failure Accommodation in Linear Systems Through Self-Reorganization, Ph.D. Thesis, Dept. of Aero., M.I.T., Cambridge, Ma., Feb. 1971.
- [24] Sworder, D.D., "Feedback Control of a Class of Linear Systems with Jump Parameters," IEEE Trans. on Automatic Control, vol. AC-14, no. 1, pp. 9-14, Feb. 1969.
- [25] Ratner, R.S. and Luenberger, D.G., "Performance-Adaptive Renewal Policies for Linear Systems," IEEE Trans. on Automatic Control, vol. AC-14, no. 4, pp. 344-351, Aug. 1969.
- [26] Sworder, D.D., "Uniform Performance-Adaptive Renewal Policies for Linear Systems," IEEE Trans. on Automatic Control, vol. AC-15, no. 5, pp. 581-583, Oct. 1970.
- [27] Bar-Shalom, Y. and Sivan, R., "On the Optimal Control of Discrete-Time Linear Systems with Random Parameters," IEEE Trans. on Automatic Control, vol. AC-14, no. 1, pp. 3-8, Feb. 1969.
- [28] Willner, Dieter, "Observation and Control of Partially Unknown Systems," Rpt. No. ESL-R-496, Electronic Systems Laboratory, M.I.T., Cambridge, Ma., Sept. 1971.
- [29] Pierce, B.D. and Sworder, D.D., "Bayes and Minimax Controllers for a Linear System with Stochastic Jump Parameters," IEEE Trans. on Automatic Control, vol. AC-16, no. 4, pp. 300-307, Aug. 1971.

- [30] Chang, C.B. and Athans, M., "Hypothesis Testing and State Estimation for Discrete Systems with Finite-Valued Switching Parameters," Rpt. No. ESL-P-758, Electronic Systems Laboratory, M.I.T., Cambridge, Ma., June 1977.
- [31] Wong, P.-K., Stein, G., Athans, M., "Structural Reliability and Robustness Properties of Optimal Linear-Quadratic Multivariable Regulators," Rpt. No. ESL-P-745, Electronic Systems Laboratory, M.I.T., Cambridge, Ma., May 1977.
- [32] Safonov, M.G. and Athans, M., "Gain and Phase Margin for Multiloop LQG Regulators," IEEE Trans. on Automatic Control, vol. AC-22, no. 2, pp. 173-179, April 1977.
- [33] Safonov, M.G. and Athans, M., "Robustness and Computational Aspects of Nonlinear Stochastic Estimators and Regulators," Rpt. No. ESL-P-741, Electronic Systems Laboratory, M.I.T., Cambridge, Ma., April 1977.
- [34] Wong, P.-K. and Athans, M., "Closed-Loop Structural Stability for Linear-Quadratic Optimal Systems," IEEE Trans. on Automatic Control, vol. AC-22, no. 1, pp. 94-99, Feb. 1977.
- [35] Wong, P.-K., "On the Interaction Structure of Linear Multi-Input Feedback Control Systems," S.M. Thesis, Dept. of Elec. Engr. and Comp. Sci., M.I.T., Cambridge, Ma., Sept. 1975.
- [36] Safonov, M.G., "Robustness and Stability Aspects of Stochastic Multivariable Feedback System Design," Ph.D. Thesis, Dept. of Elec. Engr. and Comp. Sci., M.I.T., Cambridge, Ma., Sept. 1977.
- [37] Athans, M., Ku, R., Gershwin, S.B., "The Uncertainty Threshold Principle: Fundamental Limitations of Optimal Decision Making Under Dynamic Uncertainty," Rpt. No. ESL-P-688, Electronic Systems Laboratory, M.I.T., Cambridge, Ma., Oct. 1976.
- [38] Ku, R.T. and Athans, M., "Further Results on the Uncertainty Threshold Principle," Rpt. No. ESL-P-727, Electronic Systems Laboratory, M.I.T., Cambridge, Ma., March 1977.
- [39] Ku, R., Athans, M., Varaiya, P., "The Effects of Discounted Cost on the Uncertainty Threshold Principle," Rpt. No. ESL-P-749, Electronic Systems Laboratory, M.I.T., Cambridge, Ma., April 1977.
- [40] Birdwell, J.D. and Athans, M., "On the Relationship Between Reliability and Linear Quadratic Optimal Control," Proc. 1977 IEEE Conference on Decision and Control Theory, pp. 129-134, Dec. 1977.

- [41] Athans, M., "The Matrix Minimum Principle," Information and Control, vol. 11, pp. 592-606, 1967.
- [42] Loeve, Probability Theory. New York: Van Nostrand, 1963.