

(NASA-CR-150737) FLAT GROWTH OF 7075, 7475, 7050 AND 7049 ALUMINUM ALLOY PLATE IN STRESS CORROSION ENVIRONMENTS: 2-YEAR MARINE ATMOSPHERE RESULTS (Kaiser Aluminum and Chemical Corp.) 57 p HC A04/HP A01 CSCL 11F G3/26	N78-27256 Unclas 25198
--	----------------------------------

***KAISER ALUMINUM
& CHEMICAL CORPORATION***

CENTER FOR TECHNOLOGY

RESEARCH REPORT CFT RR 78-16	June 22, 1978
FLAW GROWTH OF 7075, 7475, 7050 AND 7049 ALUMINUM ALLOY PLATE IN STRESS CORROSION ENVIRONMENTS (CONTRACT NAS8-30890): 2-YEAR MARINE ATMOSPHERE RESULTS	
R. C. Dorward and K. R. Hasse	

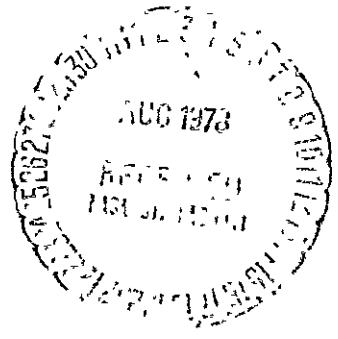

N78-27256

METALS RESEARCH

RESEARCH REPORT
CFT RR 78-16

June 22, 1978
Project 20326

FLAW GROWTH OF 7075, 7475, 7050 AND
7049 ALUMINUM ALLOY PLATE IN STRESS
CORROSION ENVIRONMENTS (CONTRACT
NAS8-30890): 2-YEAR MARINE
ATMOSPHERE RESULTS

R. C. Dorward and K. R. Hasse

R. C. Dorward

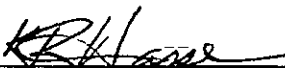
K. R. Hasse

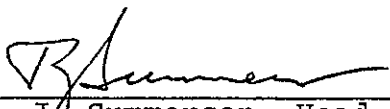
T. J. Summerson, Head
Corrosion Section

Unrestricted. This report and the information disclosed in it may be distributed to any interested party, including parties not employed by Kaiser Aluminum.

This is copy No 44.

**KAISER ALUMINUM
& CHEMICAL CORPORATION**

REPRODUCED BY
NATIONAL TECHNICAL
INFORMATION SERVICE
U. S. DEPARTMENT OF COMMERCE
SPRINGFIELD, VA 22161

DISTRIBUTION LIST

<u>Copies To:</u>	<u>Copy No.</u>
L. J. Barker	<u>1</u>
R. C. Dorward	<u>2</u>
K. R. Hasse	<u>3</u>
G. H. Kissin	<u>4</u>
E. J. Lynch	<u>5</u>
R. T. Myer	<u>6</u>
T. R. Pritchett	<u>7</u>
E. J. Westerman	<u>8</u>
J. R. Young	<u>9</u>
Alloy Metallurgy	<u>10</u>
Corrosion Sect. (20)	<u>11-30</u>
Engineering Properties	<u>31</u>
Library (6)	<u>32-37</u>
Route library	
copies to:	
M. L. Van Dreser	
E. A. Worthington	
J. J. Agness - OAK	<u>38</u>
G. J. Binczewski - OAK	<u>39</u>
J. I. Le Berre - WASH	<u>40</u>
D. J. McPherson - OAK	<u>41</u>
C. H. Walden - OAK	<u>42</u>
NASA (17)	<u>43-59</u>

July

1-a

FOREWORD

This is the first biennial report on marine atmospheric tests that were initiated under Contract NAS8-30890 for the George C. Marshall Space Flight Center of the National Aeronautics and Space Administration. The work was administered under the technical direction of the Propulsion and Vehicle Engineering Laboratory, Materials Division of the George C. Marshall Space Flight Center, with T. S. Humphries serving as Contracting Officer's Representative.

All investigations on alloys 7075-T7351, 7475-T7351, and 7050-T73651 were sponsored by NASA; costs incurred for the concurrent evaluation of alloy 7049 and for the inclusion of 7075-T651 and 7075-T7651 control materials were supported by KACC.

Although the investigation conducted under this contract was completed with the writing of the final report (October 15, 1976), marine atmospheric exposure tests are being continued for at least 6 years, the results to be reported every two years.

INTRODUCTION

The overaged alloy 7075-T73 was the first of the stress-corrosion (SC) resistant 7000-series aluminum alloys to be used in aerospace applications. Although this alloy offers excellent stress-corrosion resistance (SCR) in the short-transverse orientation, its use can result in weight penalties because of its lower strength compared to 7075-T6, 7178-T6, and 7079-T6. This situation provided the impetus for the development of alloys designed to have good SCR in combination with high strength (Refs 1, 2).

Measurements of SC susceptibility have traditionally been given in terms of the time-to-failure of "smooth" specimens which have been loaded at various stresses and then exposed to an appropriate corrosive environment. In recent years, SC tests utilizing precracked specimens have become popular because they can provide a means of determining quantitative crack growth rate information.

The objective of this program was to compare the SC behavior of the newer SC resistant, high-strength alloys (7475-T7351, 7050-T73561 and 7049-T7351) with that of the established alloy 7075-T7351. The previously reported laboratory tests and preliminary marine atmospheric results (Ref 3) on smooth and precracked specimens from 32 and 76-mm thick plates showed that for a given strength level, alloys 7050-T7X and 7049-T7X have superior short-transverse SCR to 7075-T7X. At typical strength levels above the minimum of 7075-T6, for example, the SCR of these alloys is considerably better than that of 7075-T6, and approaches that of 7075-T73.

This report updates the marine atmospheric test data, which have now been accumulated over a 26-month exposure time.

EXPERIMENTAL

Materials

Plates 32 and 76-mm (1.25 and 3.0 in.) thick having compositions shown in Table I were fabricated from 305-mm (12-in.)-thick DC-cast ingots. For comparative purposes, all the new alloys had the same purity level (0.06% Si, 0.10% Fe).

After heat treating and step-1 aging to the -T651 temper, the plates were step-2 aged by treatments selected on the basis of target tensile properties. The desired yield strength for "typical" 7075 was 34.5 MPa (5 ksi) above the minimum specified strength level for the particular plate thickness. Similarly, for 7050 and 7049, the desired typical yield strength was 27.5 MPa (4 ksi) above the minimum value. The electrical conductivities, long-transverse tensile properties, and fracture toughness of the plates are given in Table II. Properties for 7075-T651 and 7075-T7651 are also included since they were used as "control" materials in the SC tests. In all cases, the strengths of the overaged 7049 and 7050 plates were substantially greater than those of the corresponding 7075-T7351 materials, and in most instances approached the intermediate 7075-T7651 strength level. They were also equal to or greater than the minimum values specified for 7075-T651 (Ref 4).

Stress Corrosion Tests

The SC tests were conducted in a coastal marine environment near Daytona Beach, Florida with both smooth and precracked

CONTENTS

INTRODUCTION-----	1
EXPERIMENTAL-----	2
Materials-----	2
Stress Corrosion Tests-----	2
RESULTS AND DISCUSSION-----	5
Smooth Specimen Tests-----	5
Precracked Specimen Tests-----	5
SUMMARY AND CONCLUSIONS-----	9
REFERENCES-----	10
APPENDIX A - Constant-Load Stress Corrosion Tests on Precracked DCB Specimens-----	A-1
APPENDIX B - Stress Corrosion Tests of Nominal Toughness 7475 Plate-----	B-1

TABLES

I. Chemical Compositions of the Plate Materials-----	12
II. Physical Properties of the Plate Materials-----	13
III. Schedule of Bolt-Loaded DCB Tests-----	14
IV. Summary of Marine Atmosphere Short-Transverse Stress Corrosion Test Results for Smooth Specimens from 32-mm Plates--30 Months Exposure-----	15
V. Summary of Marine Atmosphere Short-Transverse SCR Results for Smooth Specimens from 76-mm Plates-- 30 Months Exposure-----	16
VI. Summary of Marine Atmosphere Long-Transverse SCR Results for Smooth Specimens-----	17
VII. Total Crack Growth Observed in DCB Specimens with Pop-in Precracks-----	18

W

FIGURES (Cont'd)

1.	Tensile Round Stress-Corrosion Specimen and Stressing Frame-----	19
2.	25-mm Constant Deflection DCB Specimen-----	20
3.	75-mm Constant Deflection DCB Specimen-----	21
4.	Bolt-Loaded DCB Specimens on Exposure at the Ocean-front Site Near Daytona Beach, Florida-----	22
5.	Crack Growth in DCB Specimens from 32-mm 7075 Plate Exposed at Daytona Beach: S-L Orientation, Pop-in Precrack-----	23
6.	Crack Growth in DCB Specimens from 76-mm 7075 Plate Exposed at Daytona Beach: S-L Orientation, Pop-in Precrack-----	24
7.	Crack Growth in DCB Specimens from 32-mm -T73 Temper Plates Exposed at Daytona Beach: S-L Orientation, Pop-in Precrack-----	25
8.	Crack Growth in DCB Specimens from 76-mm -T73 Temper Plates Exposed at Daytona Beach: S-L Orientation, Pop-in Precrack-----	26
9.	V-K Plots for 32-mm 7075 Plates: S-L DCB Specimens at Daytona Beach, Pop-in Precracks-----	27
10.	V-K Plots for 76-mm 7075 Plates: S-L DCB Specimens at Daytona Beach, Pop-in Precracks-----	28
11.	V-K Plots for 32-mm -T73 Temper Plates: S-L DCB Specimens at Daytona Beach-----	29
12.	V-K Plots for 76-mm -T73 Temper Plates: S-L DCB Specimens at Daytona Beach-----	30
13.	V-K Plots for 32-mm Plates: T-L DCB Specimens at Daytona Beach-----	31
14.	V-K Plots for 76-mm Plates: T-L DCB Specimens at Daytona Beach-----	32

✓

ABSTRACT

Continuing marine atmospheric exposure of smooth and pre-cracked specimens from 7075, 7475, 7050 and 7049 plates (26 months' exposure to date) support our original conclusion that for a given strength level, the short-transverse stress corrosion resistance of 7050-T7X and 7049-T7X is superior to that of 7075-T7X. The threshold stress intensity (K_{Isc}) for these alloys is about $25 \text{ MPa}\sqrt{\text{m}}$ at a yield strength of about 460 MPa; the corresponding yield strength level for 7075-T7X at this SCR level is about 425 MPa. Additional tests on two lots of high-toughness 7475 plate indicate that this alloy is capable of achieving K_{Isc} values of about $35 \text{ MPa}\sqrt{\text{m}}$ at yield strengths of 400-450 MPa.

Precracked specimens from all these 7XXX-series alloys are subject to self-loading from corrosion-product wedging. This effect causes stress corrosion cracks to continue growing ($>10^{-10}$ m/sec) at very low apparent (calculated) stress intensities, and should therefore be considered a potential driving force for stress corrosion in design and materials selection.

specimens. The smooth specimens were 3.175-mm-diameter tensile rounds, stressed in window frame jigs. The -T73 temper materials were exposed at four stress levels between 172 and 379 MPa (25, 35, 45, and 55 ksi). The 7075-T651 and 7075-T7651 materials were stressed at 34 to 172 MPa (5, 15, and 25 ksi) and 172 to 310 MPa (25, 35 and 45 ksi), respectively.

Crack-line loaded double cantilever beam (DCB) specimens were used for the crack growth tests. This specimen has been widely used for in-service evaluations in which crack growth behavior is studied under constant-deflection (decreasing stress intensity) conditions. The DCB test specimens were machined from the center of the plate thickness and oriented so that cracking would occur in either the short-transverse or long-transverse plain and propagate in the rolling direction (S-L and T-L orientations, respectively).

Most of the DCB specimens were 25-mm wide by 25-mm high by 125-mm long, and were precracked by mechanical "pop-in". In addition, a few 75-mm high S-L specimens were tested, and a number of fatigue-precracked S-L specimens from the thinner plates were also included. The DCB specimens had chevron notches and were sidegrooved (5% per side) to help provide a straight crack front, suppress formation of shear lips, and keep the crack growing in the proper plane (Refs 5 and 6). Table III gives a schedule of the number and types of specimens that were tested.

Prior to precracking and testing, the specimens were etch-cleaned in 5% NaOH solution at 180°C, desmutted in cold 50% HNO₃, and rinsed in hot deionized water. Most of the specimens were precracked by turning a pair of stainless steel bolts into the machined slot at the end of the specimen. The cracks were propagated about 2-3 mm beyond the end of the chevron; total crack

lengths were about 28 mm as measured from the load point. Deflections were measured with a clip-in strain gage at the integral knife edges, and crack lengths were measured optically at the specimen edges with the help of a binocular microscope.

Stress intensities were calculated from the relation (Ref 5)

$$K = \frac{\delta E h^{3/2} \phi [3(a + 0.6h)^2 + h^2]^{1/2}}{4[a + 0.6h]^3 + h^2 a} \quad (1)$$

where a is the crack length; h is the specimen beam height; δ is the deflection at the load point (determined by applying an empirical correction factor to the end measurements); E is the modulus of elasticity; and ϕ , a correction factor for side grooves, was assumed to be equal to $(b/b_n)^{0.5}$, where b and b_n are the full and reduced sections, respectively.

Specimens that were fatigue precracked were bolt loaded to about 90% of K_{Ia} . K_{Ia} , the stress intensity for mechanical arrest, was determined from the specimens precracked by mechanical pop-in. All the specimens with pop-in precracks were tested at an initial stress intensity of K_{Ia} .

After precracking and loading, the specimens were bolted to test frames and shipped by air freight to Daytona Beach. There they were suspended bolt-end down to keep runoff from the stainless steel bolts out of the cracks. Initial crack length measurements were made at approximately 1 day, 2 days, 4 days, 1 week, 2 weeks, 1 month, 2 months, 4 months, 6 months, 1 year, and 2 years. (Subsequent measurements will be made annually.) The average of the crack lengths measured at each edge was used in the calculation of stress intensity (Eq. 1) and crack growth rate.

RESULTS AND DISCUSSION

Smooth Specimen Tests

As Tables IV and V show, failures in the short-transverse specimens occurred within 12 months in the relatively susceptible 7075-T651 and 7075-T7651 control materials and in the highly stressed (310-379 MPa) 32-mm -T73 temper plates. At stress levels of 172 MPa and higher, for example, failure times for the 32-mm control plates were ≤ 2.3 months. At a stress level of 310 MPa, the 7049 and 7050-T73X specimens from the thinner plates failed in 9 months; 7075-T7351 failed in 11 months. There has been only one failure to date in the 76-mm thick -T73 temper plates (7050-T73651 stressed to 379 MPa).

Failures in the long-transverse direction occurred only in the 76-mm 7075-T651 plate stressed at 379 MPa (Table VI).

Precracked Specimen Tests

Data for these tests are expressed in the form of crack length vs. exposure time and crack velocity vs. stress intensity (V-K) plots. Total crack lengths are also listed in Table VII.

Crack length vs. time curves for the S-L-oriented specimens are shown in Figures 5 to 8. The -T651 materials, in particular, showed rapid crack growth at early exposure times (high stress intensity) followed by decreasing crack growth rate (decreasing stress intensity). After 2 to 4 months of exposure, however, crack growth in the "susceptible" materials appeared to accelerate and then proceed at a constant rate. This behavior is characteristic of corrosion product wedging effects, in which the specimen is subjected to a self-loading condition (Ref 7).

Crack extension curves for the -T73 temper plates (Figures 7 and 8) show evidence of an incubation period after which the crack growth rate increased with time, and then finally began to level off. As discussed elsewhere (Ref 8) this phenomenon may be related to a slow transition process in which the SC crack develops from the mechanical precrack. The latter type of crack is at least partly transgranular, whereas the former is intergranular. For a SC crack to initiate, therefore, it must first "find" an intergranular crack plane. This requires either transgranular SC or a mixed mode of intergranular SC and mechanical rupturing of remaining ligaments.

Crack length vs. time relations are dependent on the geometry of the specimen and on the initial stress intensity. A more rigorous evaluation involves analyzing the crack-front velocity in terms of the stress intensity at the crack tip (V-K plot). V-K plots for the 7075 plates (Figures 9 and 10) show much higher crack growth rates at a given stress intensity for the -T6 material than for the -T73 temper, with the -T76 temper having an intermediate velocity.

The influence of corrosion product wedging on the V-K relationships is also quite evident, especially in the 76-mm -T6 temper material (Fig. 10). After exposure times of 6 to 12 months, crack velocity became independent of the apparent (calculated) stress intensity as corrosion wedging provided the driving force for crack extension. This trend was also apparent in the 32-mm -T73 temper plate, but was not evident in the corresponding 76-mm material.

A comparison of the data in Figures 9 and 10 shows that crack growth rates in the "normal" V-K range (no corrosion product wedging effects) were slower in the thicker plates for a given

stress intensity. The 76-mm -T6 plate, for example, had V-K behavior similar to the 32-mm -T76 plate. This thickness effect is not uncommon in high strength aluminum alloys. Although the reasons are not fully understood, relevant factors include grain structure, strength level, and quench rate.

V-K relationships for all four 32-mm -T73 temper alloys are compared in Figure 11. In the initial stages of exposure all the materials showed similar "normal" behavior, with crack velocity decreasing with decreasing stress intensity. However, once crack velocities decreased to 10^{-10} m/sec or less (corresponding to about 6 months' exposure), the growth rate appeared to accelerate. As discussed previously, this was undoubtedly due to corrosion product wedging. The reason for the apparent maximum in the 7049 and 7050 curves is not understood--this could simply be a reflection of climatic conditions at the test site.

Data for the two precrack types (fatigue and mechanical pop-in) are in reasonably good agreement. The fatigue precracks, however, were loaded to a lower stress intensity and did not reveal the initial "normal" V-K behavior. Crack growth in these specimens was probably entirely due to corrosion-product wedging.

The data for the initial exposure period allows us to make an estimate of the "threshold" stress intensity, * K_{ISCC} (often taken to be the stress intensity at which the crack growth rate decreases to 10^{-10} m/sec or less). Such a criterion gives the following values for the 32-mm plates:

*The significance of a threshold stress intensity is questionable if stress intensities cannot be accurately determined, as for example, when corrosion product wedging occurs.

<u>Alloy</u>	<u>K_{Isc} (MPa√m)</u>
7075-T7351	24
7475-T7351	26
7050-T73651	24
7049-T7351	26

Because 7050 and 7049 have higher strength levels than 7X75 (477 and 462 MPa, respectively, compared to 420-430 MPa), they would appear to have an advantage.*

V-K data for the 76-mm -T73 temper plates are compared in Figure 12. Although the number of data points for each alloy was insufficient to plot meaningful V-K curves, it appears that there were no outstanding differences among the materials. Corrosion product wedging effects were apparent in the 7050 and 7049 plates; the 7X75 alloys have not yet shown this effect. We also note that there was no significant difference between the 25-mm-high and the 75-mm-high DCB specimens.

Figures 13 and 14 show V-K data for the T-L oriented specimens. Although these data are limited because of minimal crack growth, it appears that the -T6 temper is less resistant than the -T73 temper. In fact, the resistance of the 32-mm -T6 temper plate in the T-L orientation is approximately the same as that of the -T73 temper in the S-L orientation. Alloy differences in the overaged -T73 temper conditions were difficult to discern. Of the four alloys, 7475-T7351 was probably the most resistant. T-L threshold stress intensities were above 26 MPa√m for all -T73 temper materials.

*We note that the toughness of the 7475 plates evaluated in this study was somewhat lower than the minimum requirements of the alloy. Additional tests on high-toughness material (see Appendix B) indicate that K_{Isc} values of 35 MPa√m are possible in combination with yield strengths of 400-450 MPa.

SUMMARY AND CONCLUSIONS

Results obtained from an extended exposure of smooth and precracked specimens from 7XXX alloy plates to a marine environment support our original contention (Ref 3) that for a given strength level, alloys 7050 and 7049 have short-transverse stress corrosion resistance (SCR) superior to that of 7075 and 7475.* And, at equal strength levels, there are no significant differences in short transverse SCR between 7050 and 7049.

The results also show that precracked DCB specimens may be subject to corrosion product wedging upon long-term exposure to marine atmosphere. This causes the specimen to become self-loading, compromising quantitative assessments of crack-growth rate and stress intensity. Corrosion product wedging, however, is as likely to occur in the "real world" as in our tests, and it should therefore be considered a potential driving force for SC.

*As shown in Appendix B, 7475 is capable of achieving higher K_{Isc} values, but at somewhat lower strength levels than 7050 and 7049.

REFERENCES

1. J. V. Luhan and T. J. Summerson, "Development of 7049-T73 High-Strength, Stress-Corrosion Resistant Aluminum Alloy Forgings," Metals Engineering Quarterly, 10, No. 14, p. 35 (1970).
2. J. T. Staley and H. Y. Hunsicker, "Exploratory Development of High-Strength, Stress-Corrosion Resistant Aluminum Alloy for Use in Thick Section Applications," Technical Report, AFML-TR-70-256, November 1970.
3. R. C. Dorward and K. R. Hasse, "Flaw Growth of 7075, 7475, 7049 and 7050 Aluminum Alloy Plate in Stress Corrosion Environments, Final Report, Contract NAS8-30890", October 15, 1976.
4. Aluminum Standards and Data, The Aluminum Association, p. 110, 1976.
5. S. Mostovoy, P. B. Crosley, and E. J. Ripling, "Use of Crack-Line-Loaded Specimens for Measuring Plane Strain Fracture Toughness", Journal of Materials, 2, p. 661 (1967).
6. C. N. Freed and J. M. Krafft, "Effect of Side Grooving on Measurements of Plane Strain Fracture Toughness," Journal of Materials, 1, p. 770 (1966).
7. R. C. Dorward, K. R. Hasse and W. J. Helfrich, "Marine Atmospheric Stress Corrosion Tests on Precracked Specimens from High-Strength Aluminum Alloys: Effect of Corrosion Product Wedging," ASTM Journal of Testing and Evaluation, in press.

8. R. C. Dorward and K. R. Hasse, "Incubation Effects in Precracked Stress Corrosion Specimens from Al-Zn-Mg-Cu Alloy 7075," Corrosion Science, in press.
9. M. O. Speidel, "Stress Corrosion Cracking of Aluminum Alloys," Metallurgical Transactions, Vol. 6A, p. 631 (1975).
10. R. C. Dorward and K. R. Hasse, "A Comparison of Constant-Load and Constant-Deflection Stress Corrosion Tests on Precracked Specimens," International Journal of Fracture, 14, p. R31 (1978).
11. I. M. Austen, R. Brook and J. M. West, "Effective Stress Intensities in Stress Corrosion Cracking," International Journal of Fracture, 12, p. 253 (1976).
12. J. E. Finnegan and W. H. Hartt, "Stress Intensity Dependence of Stress Corrosion Crack-Growth Rate in 7079-T651 Aluminum," in Stress Corrosion--New Approaches, H. L. Craig, Ed., ASTM STP 610, p. 44 (1976).
13. P. L. Mehr, "Alcoa 7475 Sheet and Plate", Alcoa Green Letter, October, 1973.

Table I. Chemical Compositions of the Plate Materials

Alloy	Plate* Thickness, mm	% by Weight**							
		Si	Fe	Cu	Mg	Cr	Zn	Ti	Zr
7075	32	0.14	0.16	1.45	2.49	0.20	5.78	0.03	0.00
7075	76	0.14	0.16	1.46	2.50	0.20	5.91	0.03	0.00
7475	32	0.06	0.10	1.57	2.23	0.20	5.96	0.02	0.00
7475	76	0.06	0.10	1.55	2.20	0.20	5.97	0.02	0.00
7050	32	0.06	0.10	2.10	2.08	0.00	6.00	0.02	0.12
7050	76	0.06	0.10	2.09	2.07	0.00	6.10	0.02	0.12
7049	32	0.06	0.10	1.53	2.48	0.14	7.60	0.02	0.00
7049	76	0.06	0.10	1.55	2.54	0.14	7.54	0.02	0.00

Note:

Cu, Mg and Zn based on atomic absorption analysis of the plates;
Si, Fe, Cr, Ti, and Zr based on Quantometer analysis of the melts
and plates.

*Both plates of each alloy were rolled from the same ingot.

**All other elements <0.005% each; <0.05% total.

Table II. Physical Properties of the Plate Materials

Material	Plate Thickness (mm)	Electrical Conductivity (% IACS)	Strength (MPa)		Elongation (% in 2 in.)	Fracture Toughness (MPa√m)	
			UTS	YS		L-T	S-L
7075-T651	32	33.2	584	522	10.7	25.1	24.2
7075-T651	76	34.0	559	500	7.7	22.4	19.6
7075-T7651	32	38.4	544	489	10.2	25.2	23.1
7075-T7651	76	39.5	521	460	7.7	22.0	21.3
7075-T7351	32	41.6	498	429	10.5	26.7	24.3
7075-T7351	76	42.1	464	382	9.0	24.8	23.5
7475-T7351	32	43.4	495	420	11.7	31.7	26.7
7475-T7351	76	44.8	470	385	10.0	30.5	29.7
7050-T73651	32	41.9	537	477	11.8	31.2	27.3
7050-T73651	76	43.2	502	429	8.8	29.2	27.9
7049-T7351	32	42.5	520	461	11.0	31.2	27.8
7049-T7351	76	41.7	525	450	9.8	27.2	27.6

Notes: Tensile properties and fracture toughness values are averages for triplicate specimens. Tensile properties are for long-transverse direction (YS is 0.2% offset).

Table III. Schedule of Bolt-Loaded DCB Tests

Material	Thickness (mm)	Number of Specimens	
		S-L Orientation	T-L Orientation
7075-T651	32	1	1
7075-T7651		1	1
7075-T7351		3*	3
7075-T651	76	1	1
7075-T7651		1	1
7075-T7351		3**	3
7475-T7351	32	3*	3
7475-T7351	76	3**	3
7050-T73651	32	3*	3
7050-T73651	76	3**	3
7049-T7351	32	3*	3
7049-T7351	76	3**	3

Note: All specimens were 25-mm high with pop-in precracks. One specimen from each set (except 7075-T651 and 7075-T7651) was removed after 6 months' exposure.

* Indicates two 25-mm-high fatigue-precracked specimens were also tested.

**Indicates two 75-mm-high specimens were also tested (pop-in precrack).

Table IV. Summary of Marine Atmosphere Short-Transverse Stress Corrosion Test Results for Smooth Specimens from 32-mm Plates--30 Months Exposure

Applied Stress, MPa (ksi)	Alloy/Temper					
	7075					
	-T651	-T7651	T7351 (T)	7475-T7351 (T)	7050-T73651 (T)	7049-T7351 (T)
	[522]*	[489]	[429]	[420]	[477]	[462]
34 (5)	OK	-	-	-	-	-
103 (15)	2/2 (9,15 mo)	-	-	-	-	-
172 (25)	3/3 (.1-.2 mo)	3/3 (.9-2.3 mo)	OK	OK	OK	OK
241 (35)	-	3/3 (.4-1.2 mo)	OK	OK	OK	1/3 (16 mo)
310 (45)	-	3/3 (.1-.4 mo)	3/3 (11,22,25 mo)	OK	3/3 (9 mo)	2/3 (9 mo)
379 (55)	-	-	2/3 (11,15 mo)	OK	3/3 (3.4,5, 11 mo)	3/3 (9 mo)

Notes: Results are listed as number specimens failed/number tested; OK indicates 3 specimens survived 30-month exposure. Specimen: 3.175-mm-diam. tensile type.

*Numbers in brackets are LT yield strengths (MPa). Minimum yield strengths for 32-mm 7075-T651 and 7075-T7351 are 462 and 393 MPa, respectively.

Table V. Summary of Marine Atmosphere Short-Transverse SCR Results
for Smooth Specimens from 76-mm Plates--30 Months Exposure

Applied Stress, ksi	Alloy/Temper					
	7075 -T651	7075 -T7651	-T7351 (T)	7475-T7351 (T)	7050-T73651 (T)	7049-T7351 (T)
	[500]*	[460]	[382]	[384]	[429]	[449]
34 (5)	OK	-	-	-	-	-
103 (15)	3/3 (.1-.4 mo)	-	-	-	-	-
172 (25)	2/2 (.05 mo)	OK	OK	OK	OK	OK
241 (35)	-	2/3 (6,11 mo)	OK	OK	OK	OK
310 (45)	-	3/3 (.5-1.8 mo)	OK	OK	OK	OK
379 (55)	-	-	OK	OK	1/3 (19 mo)	OK

Notes: Results are listed as number specimens failed/number tested; OK indicates 3 specimens survived 30-month exposure. Specimen: 3.175-mm-diam. tensile type.

*Numbers in brackets are LT yield strengths (MPa). Minimum yield strengths for 64-76-mm 7075-T651 and 7075-T7351 are 420 and 338 MPa, respectively.

Table VI. Summary of Marine Atmosphere Long-Transverse
SCR Results for Smooth Specimens

Applied Stress, MPa (ksi)	Alloy/Temper					
	-T651	7075 -T7651	-T7351 (T)	7475-T7351 (T)	7050-T73651 (T)	7049-T7351 (T)
	<u>32 mm Plate</u>					
310 (45)	-	-	OK	OK	OK	OK
379 (55)	OK	OK	OK	OK	OK	OK
	<u>76 mm Plate</u>					
310 (45)	-		OK	OK	OK	OK
379 (55)		OK (345 MPa)	OK	OK	OK	OK

Notes: Results are listed as number specimens failed/number tested; OK indicates 3 specimens survived 30-month exposure. Specimen: 3.175-mm-diam. tensile type.

Table VII. Total Crack Growth Observed in DCB Specimens with Pop-in Precracks

Material	Plate Thickness, mm	LT Yield Strength, MPa	K_{Ia} MPa \sqrt{m}	Crack Extension [‡] mm	
				S-L	T-L
7075-T651	32	522	23.6	48.5	3.6
7075-T7651		489	23.8	23.4	0.5
7075-T7351		429	26.1	6.6	3.8
7075-T651	76	500	22.6	59.7	2.3
7075-T7651		460	23.8	8.9	0.3
7075-T7351		382	26.7	0.6	0.9
7475-T7351	32	420	32.8	7.7	1.7
7475-T7351	76	384	33.9	2.4	0.9
7050-T73651	32	477	28.3	20.4	2.7
7050-T73651	76	429	30.5	6.9	3.0
7049-T7351	32	462	30.9	13.3	2.9
7049-T7351	76	449	29.6	8.1	2.2

*Estimate based on average of measurements at specimen edges at end of 26-month exposure period.

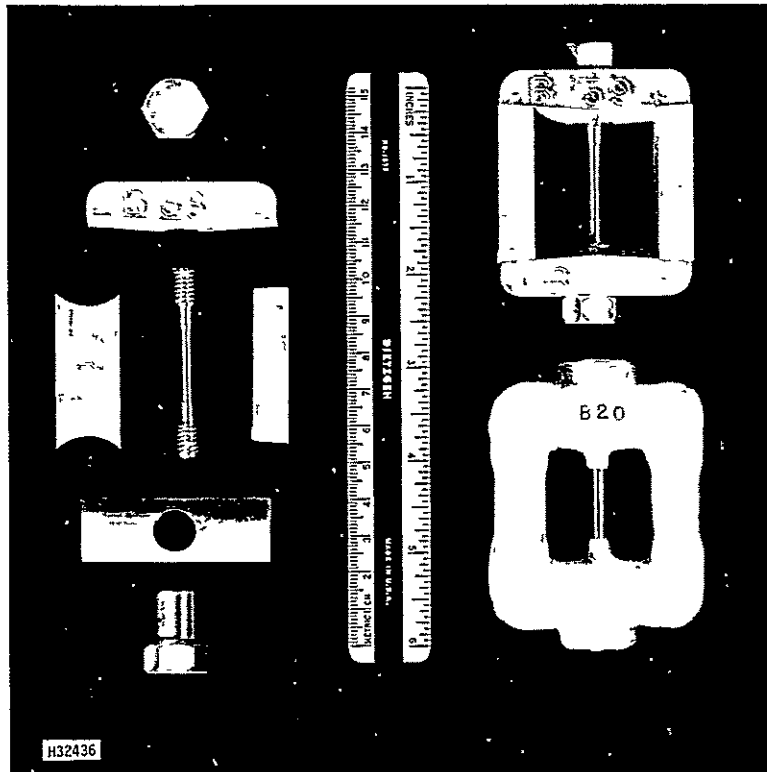

Figure 1. Tensile Round Stress-Corrosion Specimen and Stressing Frame

Left: 3.175-mm-diameter tensile specimen and components of the stressing frame.

Upper Right: Assembled frame with specimen as it appears before stressing.

Lower Right: Stressed specimen and frame coated with 5% polyethylene-paraffin wax (for laboratory tests). Marine atmosphere frames are anodized.

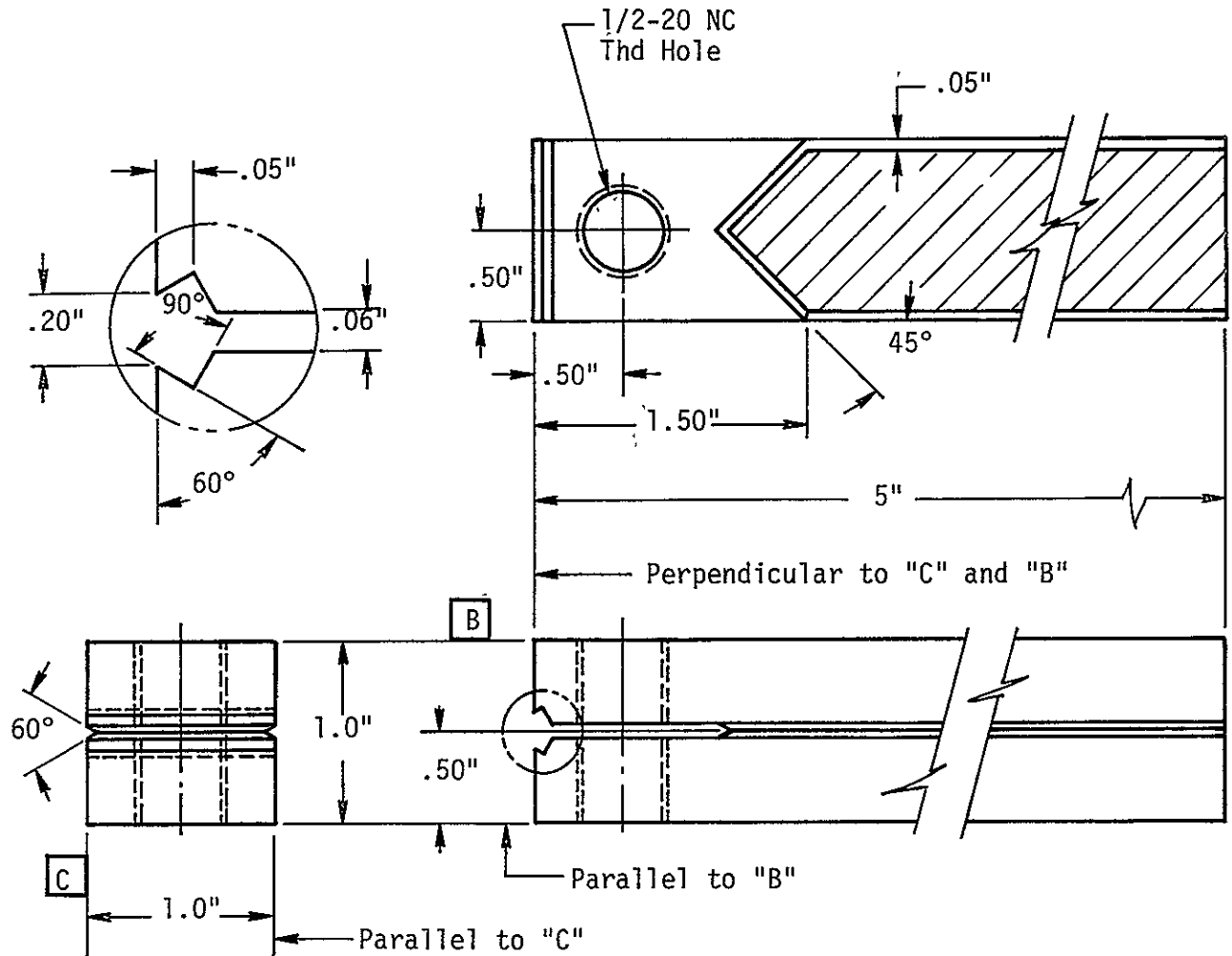

Figure 2. 25-mm Constant Deflection DCB Specimen

Fatigue-precracked specimens contained both bolt holes and pin-loading holes. (All dimensions in inches.)

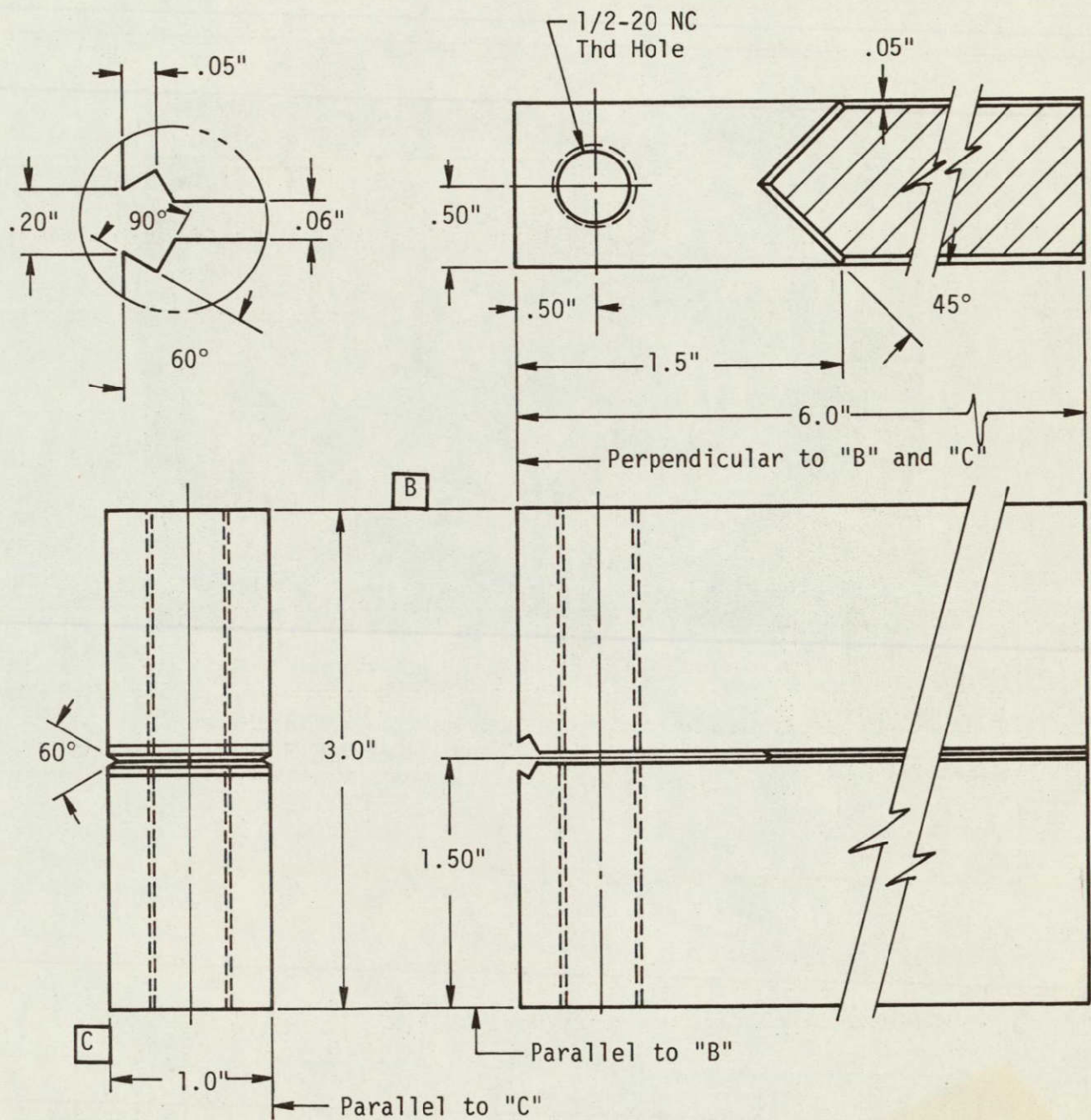

Figure 3. 75-mm Constant Deflection DCB Specimen
(All dimensions in inches)

ORIGINAL PAGE IS
OF POOR QUALITY

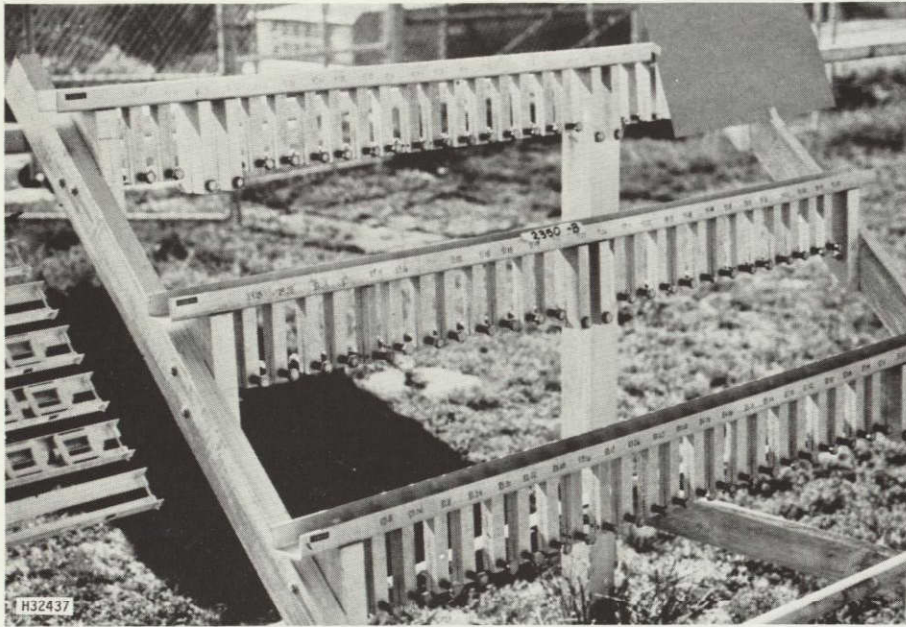

Figure 4. Bolt-Loaded DCB Specimens on Exposure at
the Oceanfront Site Near Daytona Beach, Florida

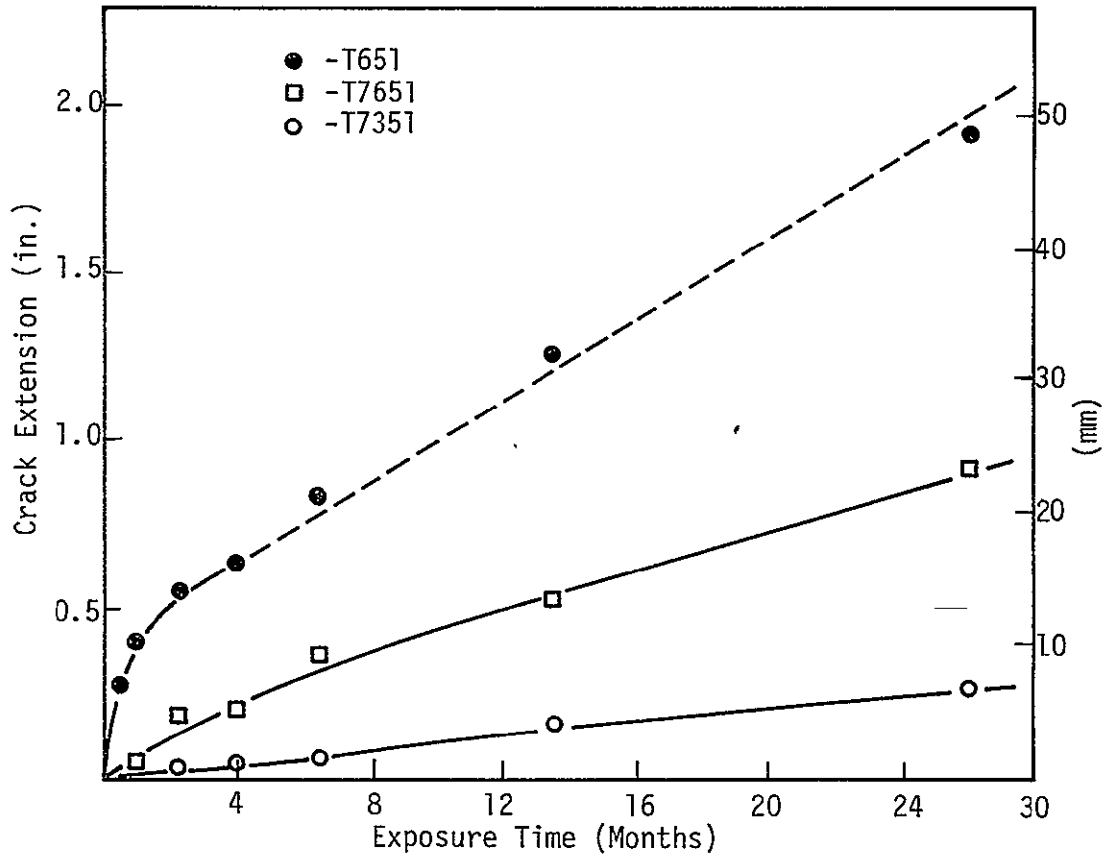

Figure 5. Crack Growth in DCB Specimens from 32-mm 7075 Plate Exposed at Daytona Beach: S-L Orientation, Pop-in Precrack

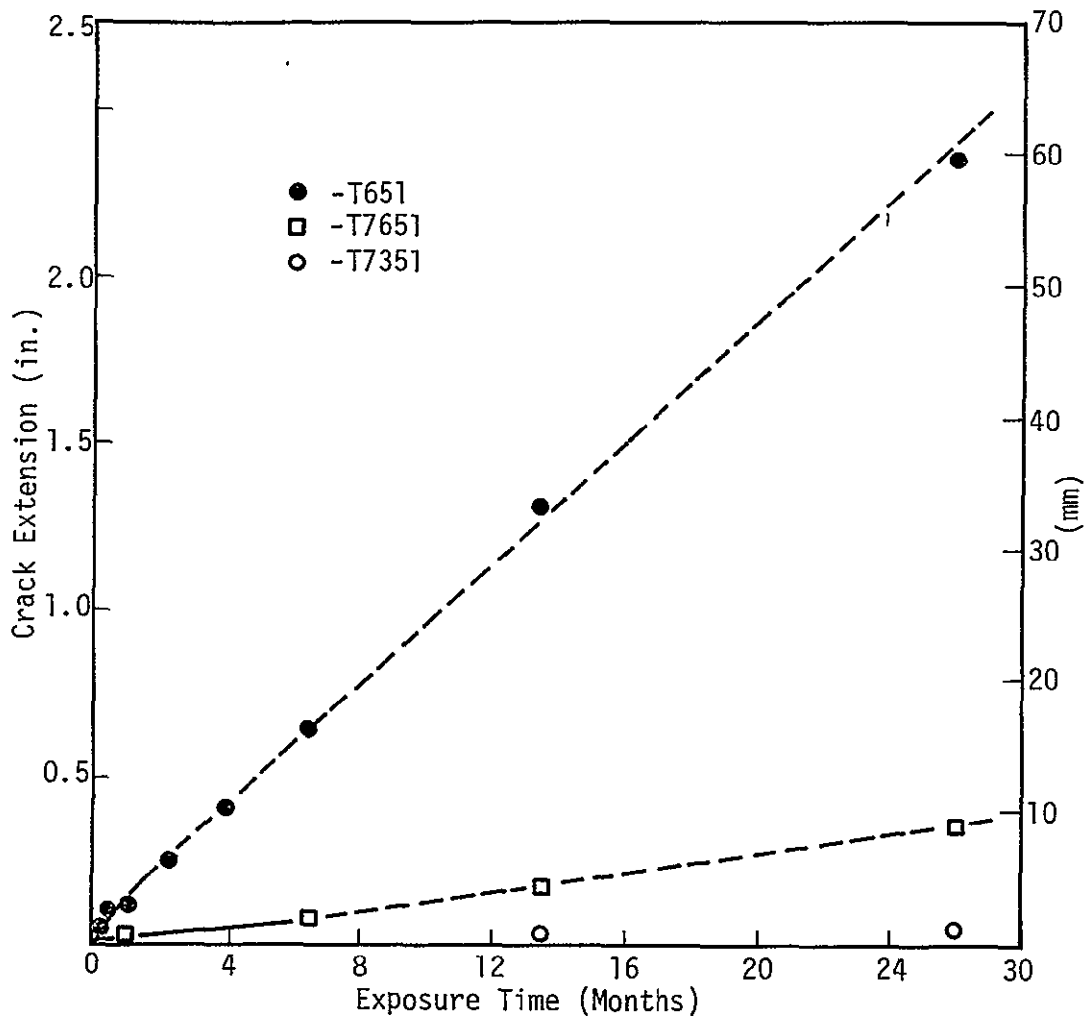

Figure 6. Crack Growth in DCB Specimens from 76-mm 7075 Plate Exposed at Daytona Beach: S-L Orientation, Pop-in Precrack

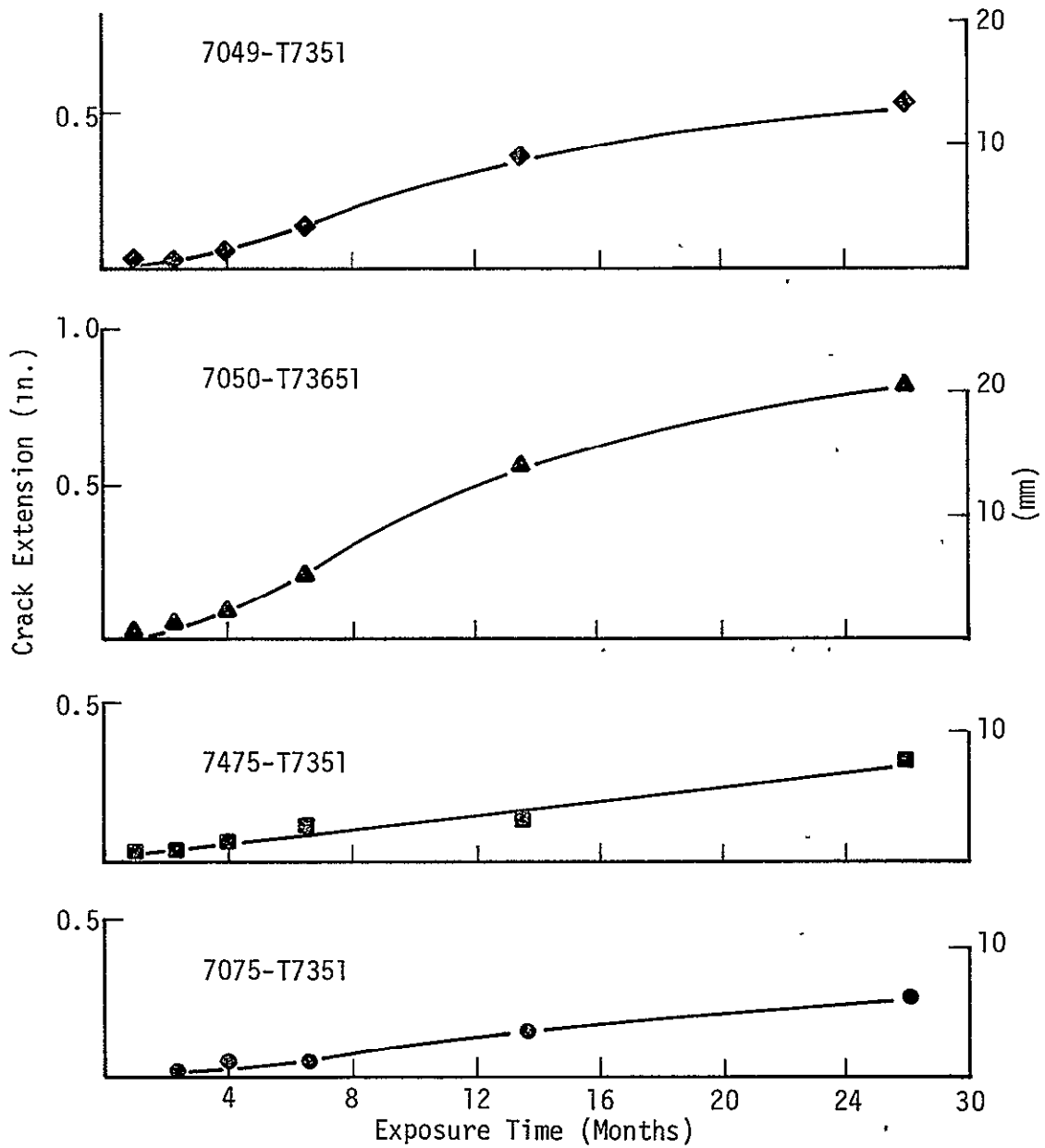

Figure 7. Crack Growth in DCB Specimens from 32-mm -T73 Temper Plates Exposed at Daytona Beach: S-L Orientation, Pop-in Precrack

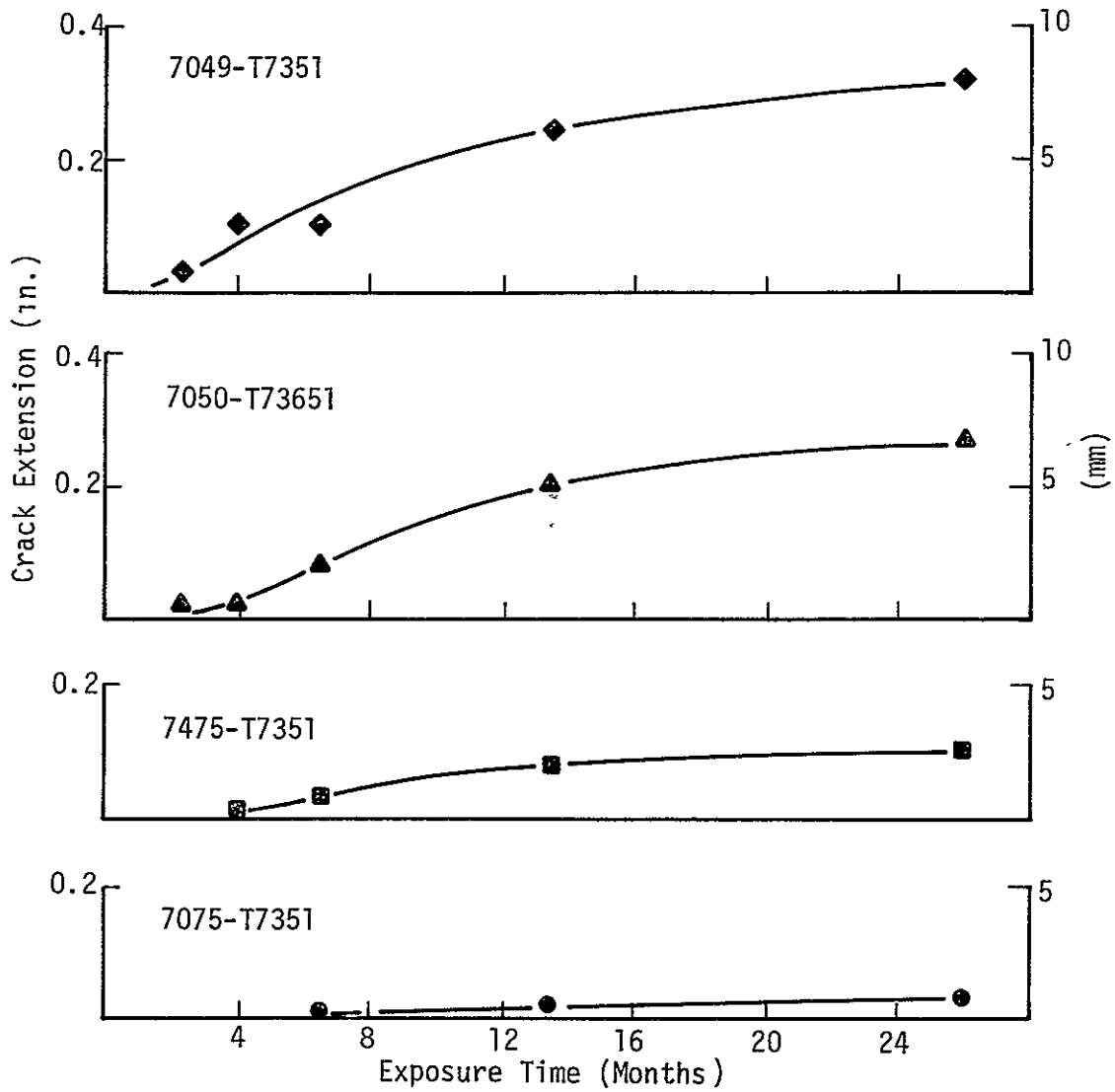
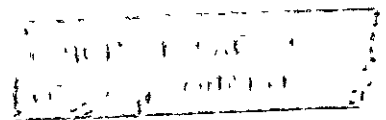

Figure 8. Crack Growth in DCB Specimens from 76-mm -T73 Temper Plates Exposed at Daytona Beach: S-L Orientation, Pop-in Precrack



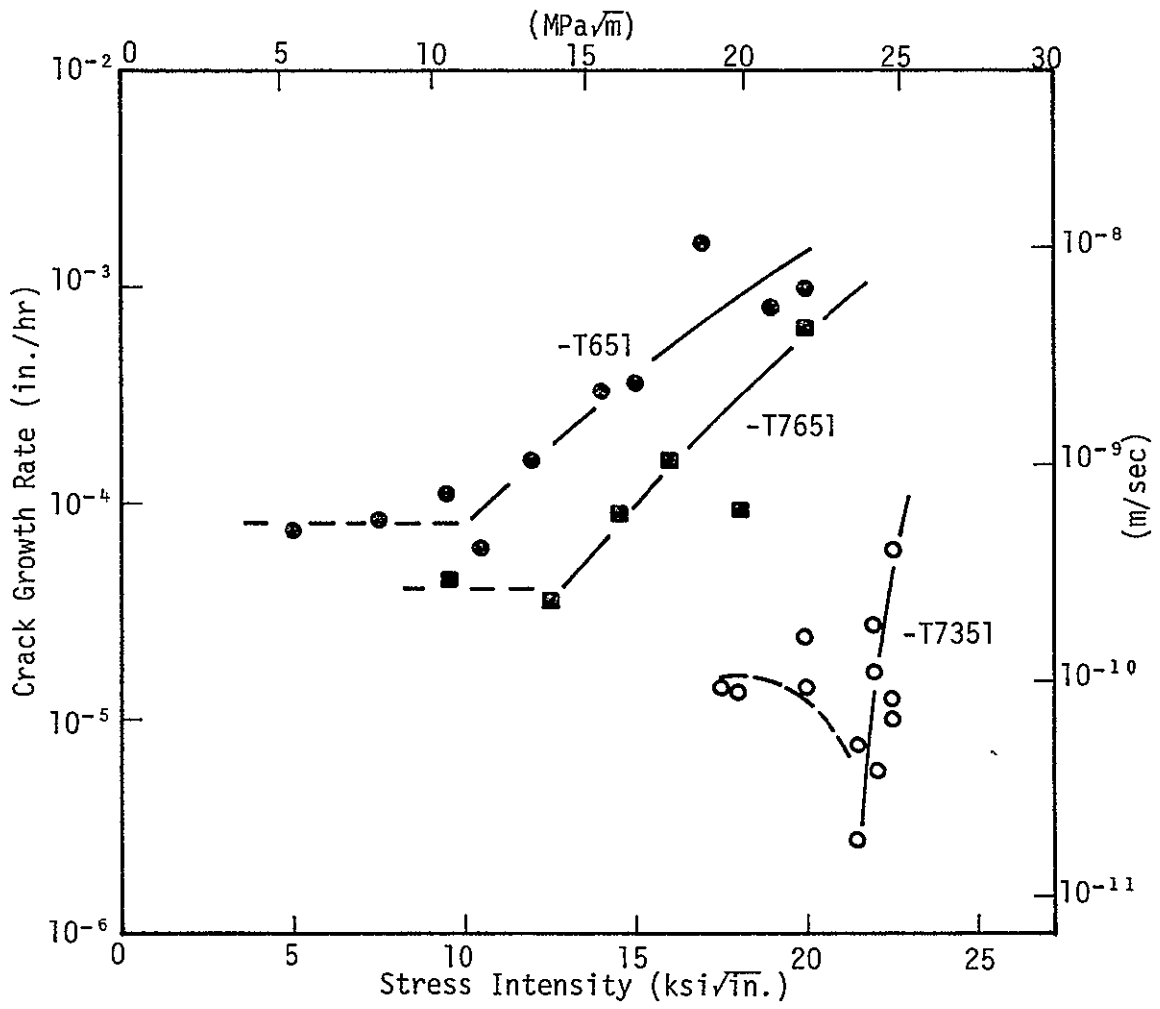

Figure 9. V-K Plots for 32-mm 7075 Plates: S-L DCB Specimens at Daytona Beach, Pop-in Precracks

Dashed lines are for exposure period from 6 to 26 months.

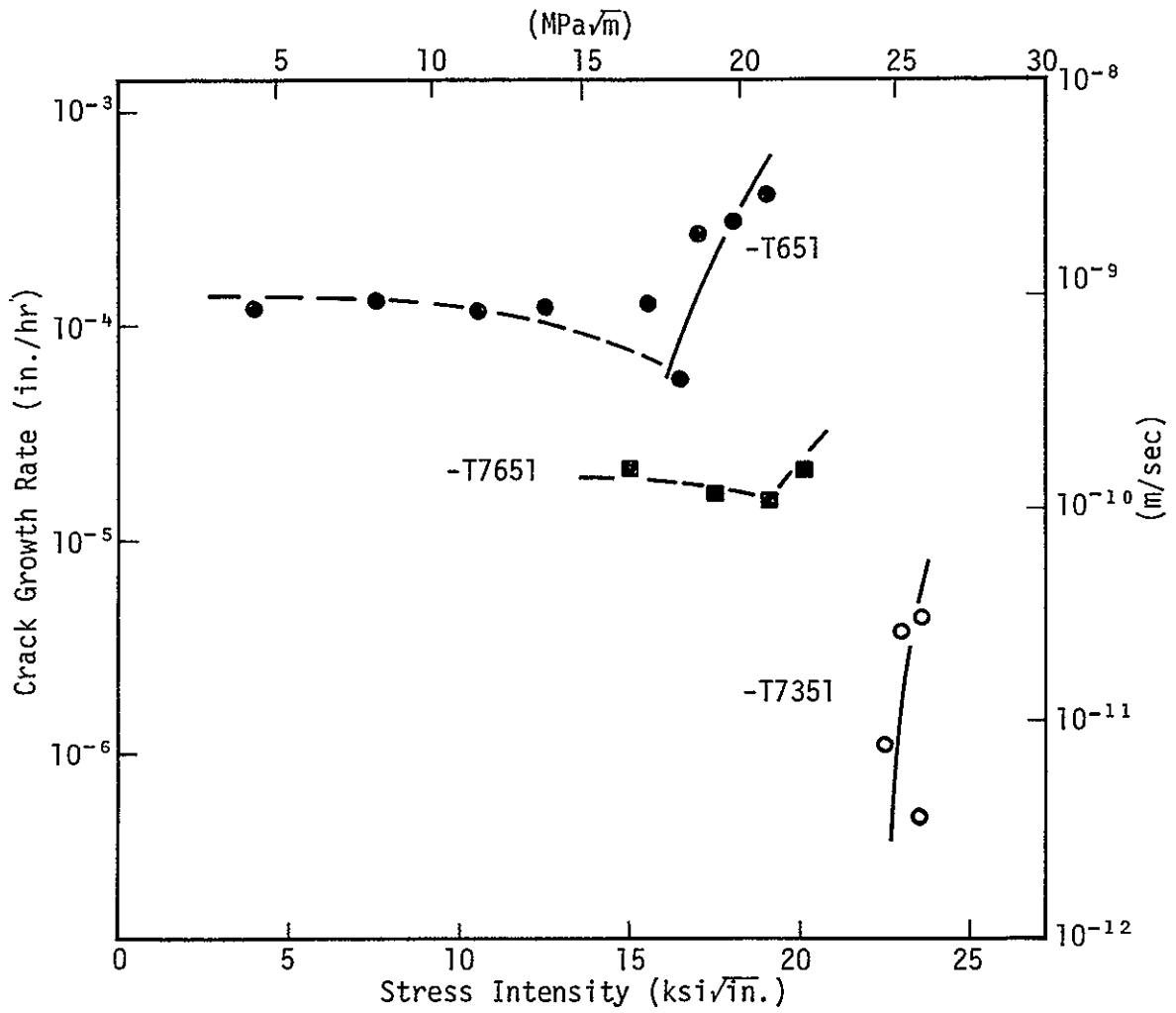

Figure 10. V-K Plots for 76-mm 7075 Plates: S-L DCB Specimens at Daytona Beach, Pop-in Precracks

Dashed lines are for exposure period from 6 to 26 months.

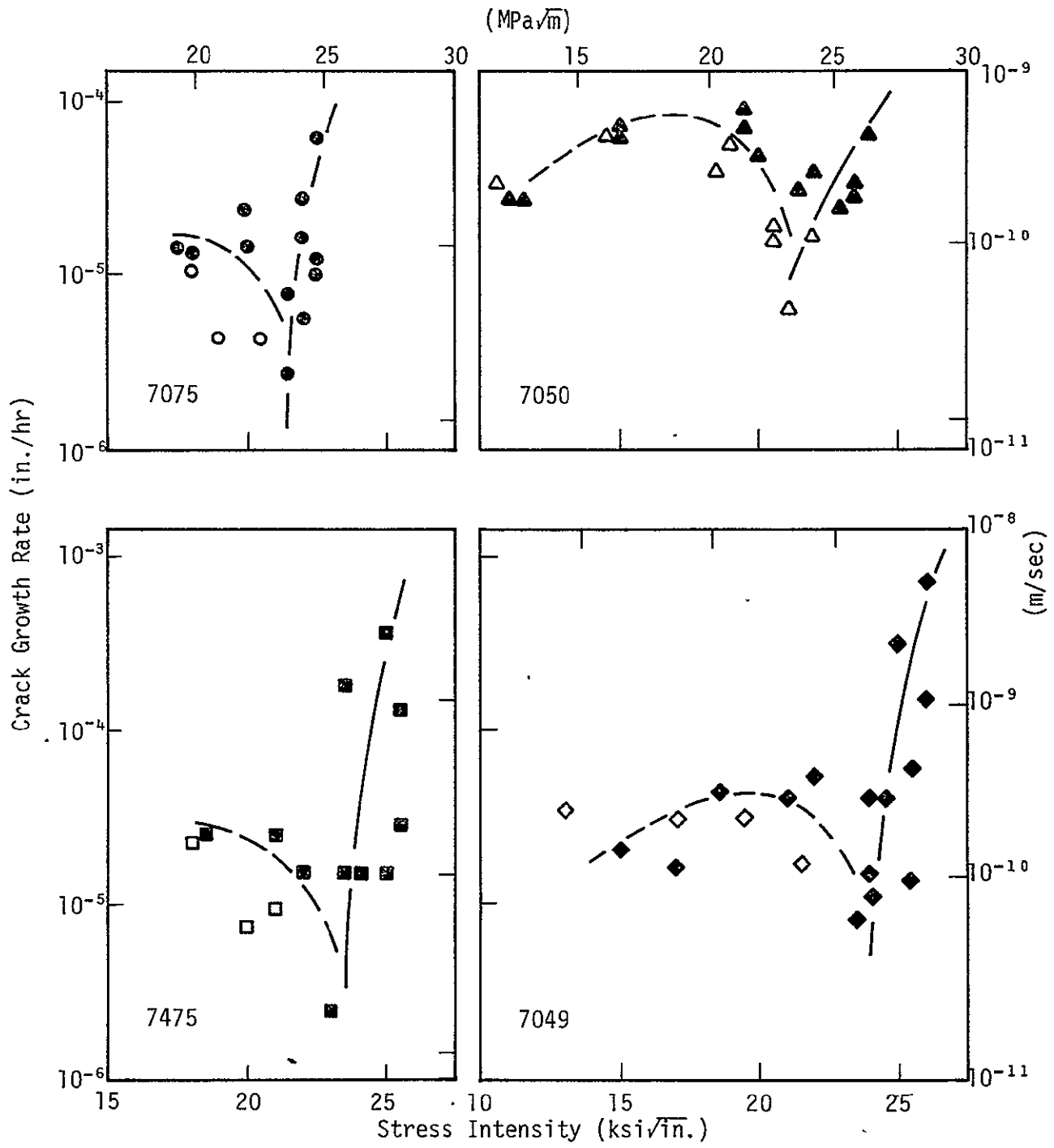

Figure 11. V-K Plots for 32-mm -T73 Temper Plates: S-L DCB Specimens at Daytona Beach.

Solid symbols: pop-in precracks
 Open symbols: fatigue precracks

Dashed lines are for exposure period from 6 to 26 months.

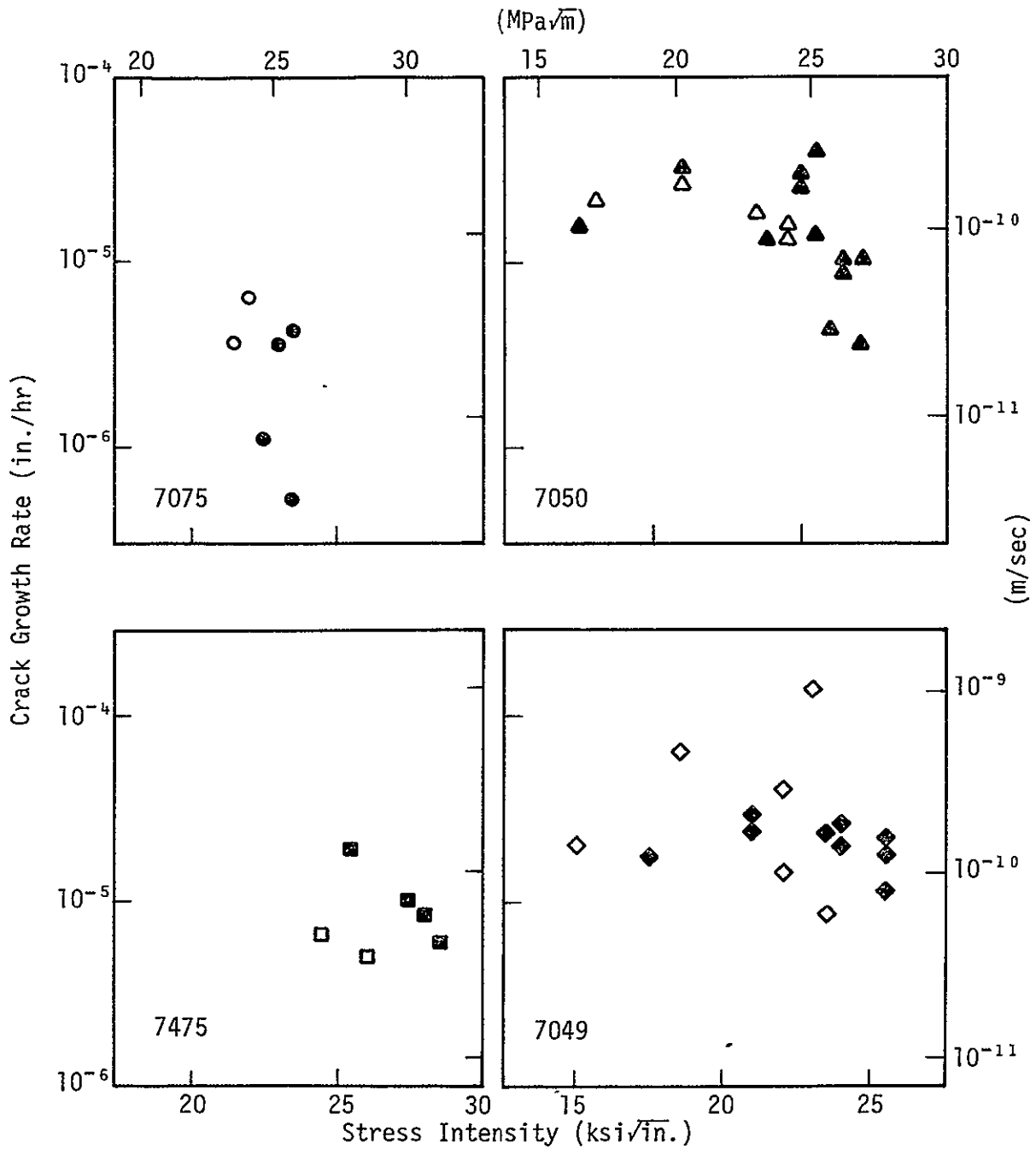

Figure 12. V-K Plots for 76-mm -T73 Temper Plates: S-L DCB Specimens at Daytona Beach
 Solid symbols: 25-mm-high specimens
 Open symbols: 75-mm-high specimens

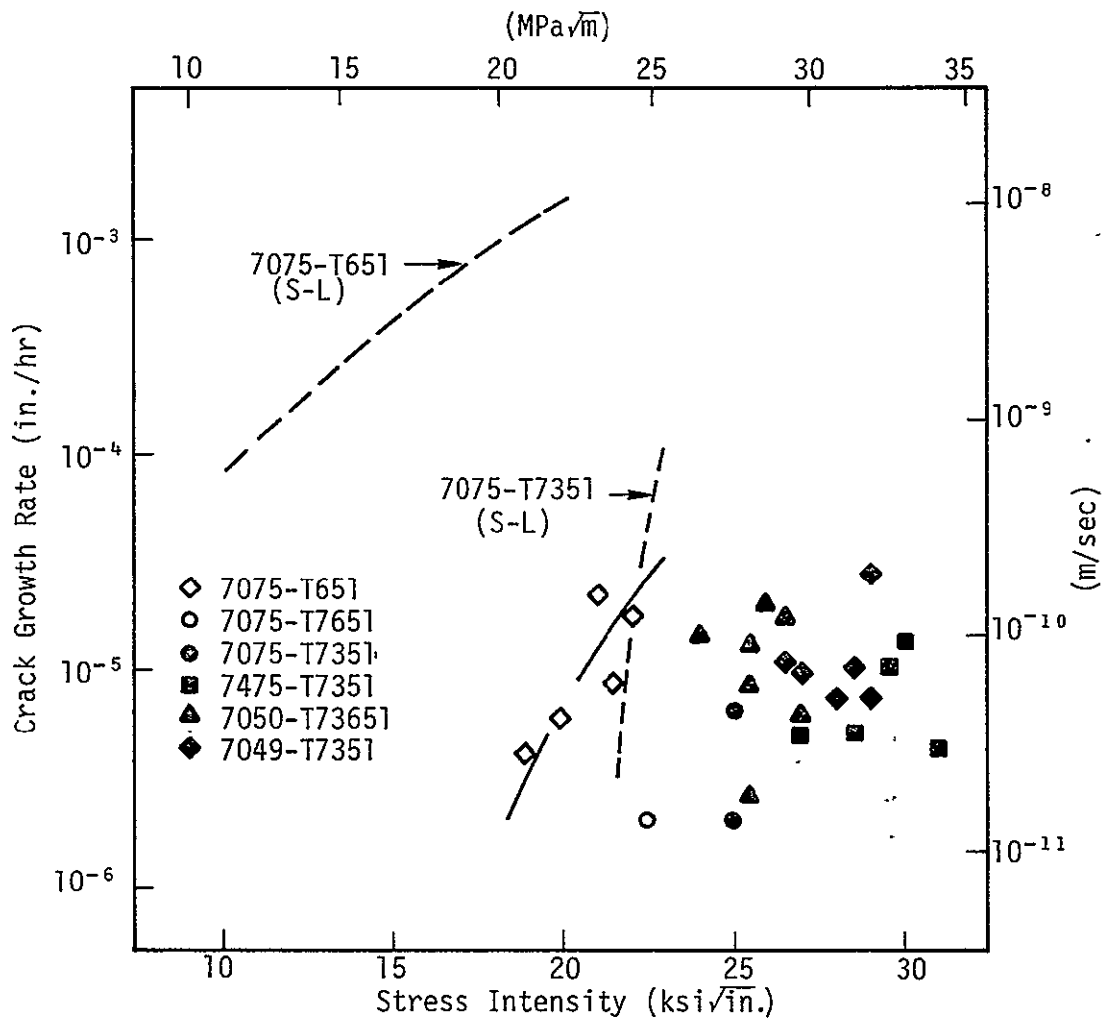

Figure 13. V-K Plots for 32-mm Plates: T-L DCB Specimens at Daytona Beach

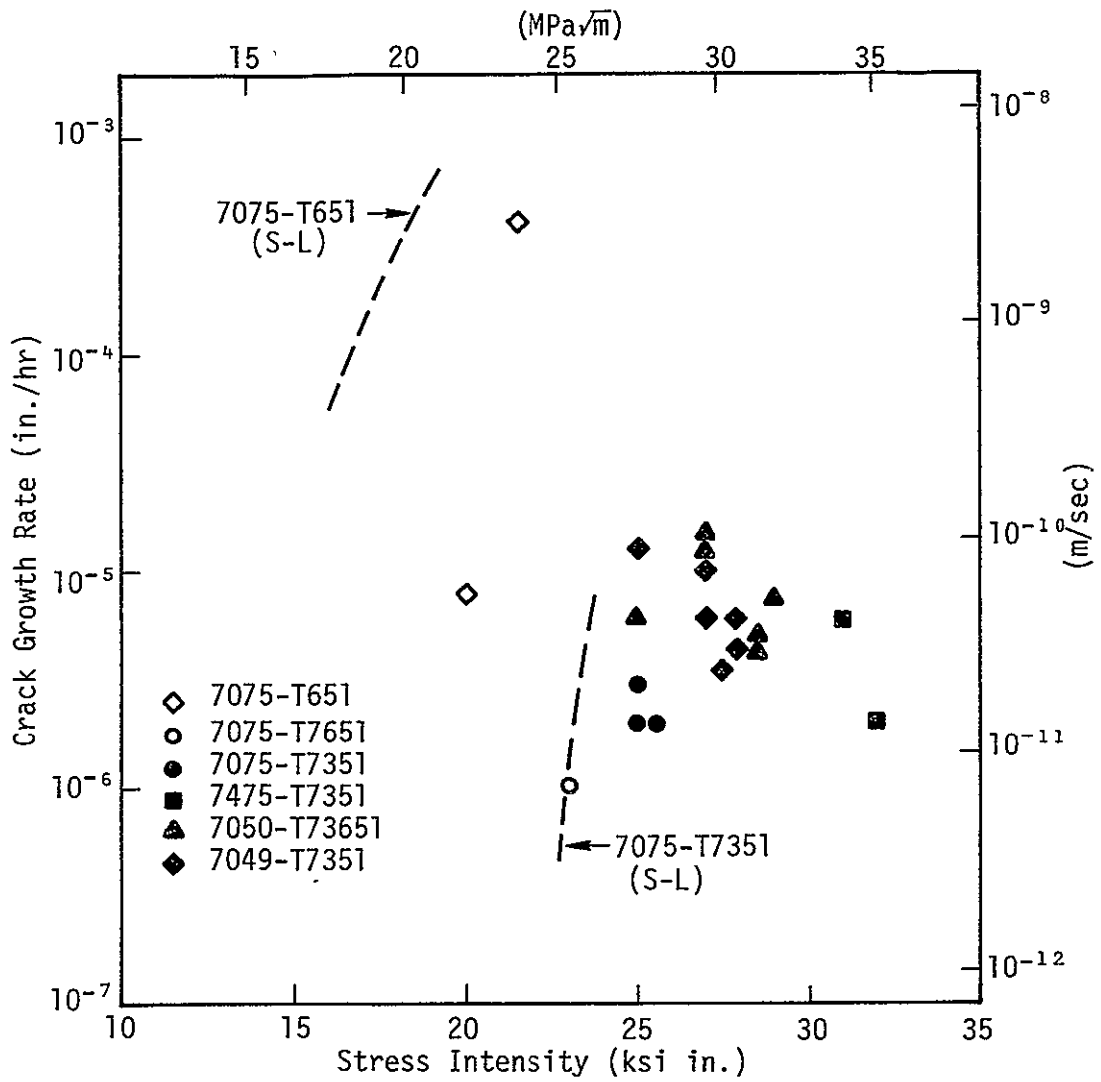

Figure 14. V-K Plots for 76-mm Plates: T-L DCB Specimens at Daytona Beach

APPENDIX A
CONSTANT-LOAD STRESS CORROSION TESTS
ON PRECRACKED DCB SPECIMENS

Under Contract NAS8-30890, Kaiser Aluminum was committed to conduct constant load tests on fatigue precracked specimens from the 7075-T651 and 7075-T7651 control materials (at no cost to NASA). As these laboratory tests were of long duration (up to 9 months), the results were not presented in the final report. The tests have now been completed and are reported herein.

Experimental

S-L DCB specimens, machined from the 76-mm 7075-T651 and 7075-T7651 plates, had the same dimensions as shown in Figure 2, except that they contained pin-loading holes rather than bolt holes. Fatigue precracks were introduced with an axial fatigue machine and the specimens were then loaded in creep-rupture stands (Figure A-1). Deflections were monitored with linear voltage transducers.

The specimens were exposed to two environments: buffered salt-chromate solution (0.6M NaCl - 0.02M Na₂Cr₂O₇ - 0.07M NaC₂H₃O₂ + HC₂H₃O₂ to pH 4) and 3.6% synthetic sea salt solution. These solutions were automatically metered to the crack front.

Crack lengths and stress intensities were calculated from the measured deflections using published compliance formulae (Ref 5). Crack velocities were obtained from crack length changes over a definite time increment. The velocity was then plotted against the average calculated stress intensity for that time period (V-K curve), and the results were compared with those obtained on

the same materials using bolt-loaded, constant-deflection specimens (Ref 3).

Results

V-K curves for the two tempers exposed to the salt-chromate environment are shown in Figure A-2. Agreement between the two loading methods was quite good. There was a tendency towards a plateau region (velocity independent of stress intensity) for both materials, but it was not as pronounced as often idealized (Ref 9). It is also noteworthy that stable crack growth occurred at apparent stress intensities well above K_{IC} (the 7075-T651 sample failed at a stress intensity $8 \text{ MPa}\sqrt{\text{m}}$ above K_{IC} --see Table II, main text).

Figures A-3 and A-4 show V-K curves for the artificial seawater environment. The constant-load curves for both materials were substantially displaced from those for the bolt-loaded specimens (lower crack velocity for a given stress intensity). Crack growth in the direct-loaded -T651 temper material was so slow at the initial stress intensity that the load was increased after about 4 months of exposure. The -T7651 temper material never did fracture in the 9-month total exposure period.

Discussion

The reason for the difference between constant load and constant deflection data in the synthetic seawater environment is not clear. A possible explanation may involve the amount of general corrosion and crack front blunting that can occur in this solution (Ref 10). Metallographic cross sections showed much wider and blunter cracks in the constant-deflection specimens tested in synthetic seawater than in those exposed to the salt-chromate solution (Ref 3). Since the stress intensity that a

crack can sustain is proportional to the square root of its tip radius, blunt cracks require a higher apparent stress intensity for propagation (Ref 11). Long-term exposure at a low stress intensity could therefore precondition the material so that it would be relatively resistant at successively higher stress intensity levels.

This argument is supported by the occurrence of stable crack growth at apparent stress intensities above K_{IC} . However, this rationale does not explain why the 7075-T651 sample tested in the salt-chromate solution ultimately fractured at a higher stress intensity than the one exposed to synthetic seawater.

Further work should be conducted in this area. There are indications for example, that crack growth rates are not a unique function of stress intensity and may instead depend on exposure time; consequently, the position of the V-K curve is dependent on the initial stress intensity (Ref 11). It should be established whether such observations are due to crack blunting (or branching) effects as suggested in this study.

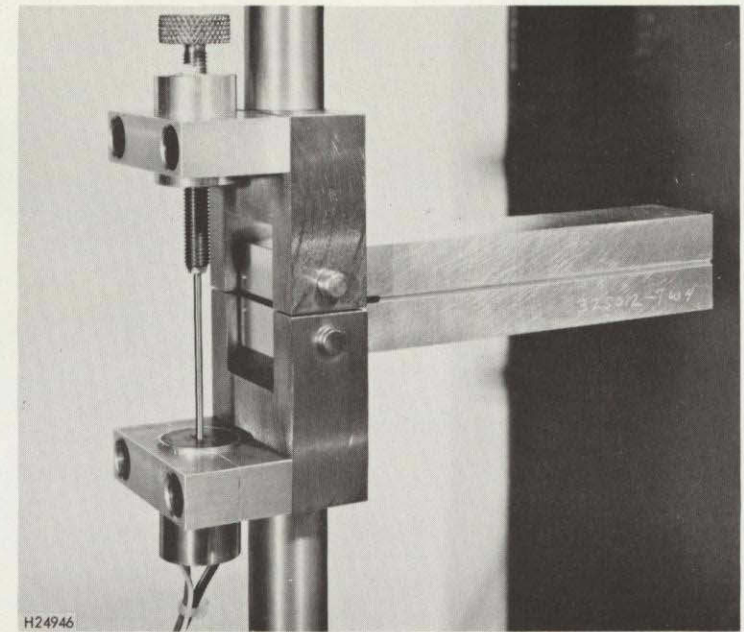

Figure A-1. Direct Load Tests of DCB Specimens

Left: Creep rupture stands are used to apply a constant load to DCB specimens. Power supply and data acquisition system for excitation and recording of output (respectively) from LVDT's are at right in photo.

Right: DCB specimen and the LVDT used to monitor deflection of the specimen are shown in greater detail.

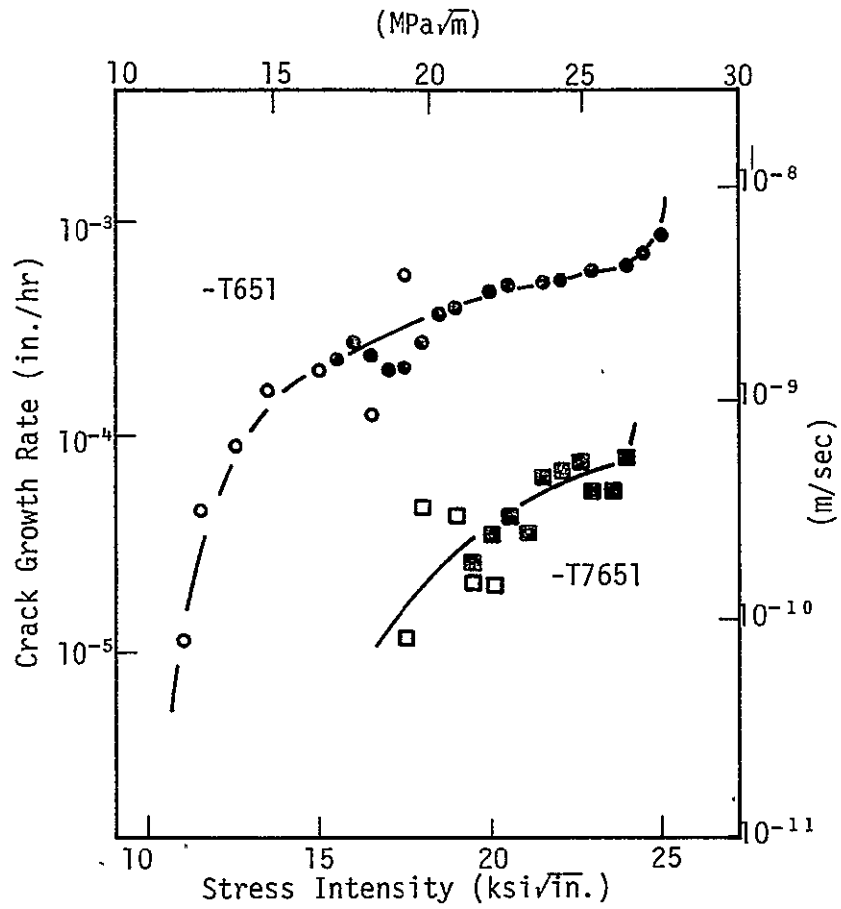

Figure A-2. V-K Plots for 7075-T651 and -T7651 Plate as Determined with S-L DCB Specimens Exposed to Buffered Salt-Chromate Solution

Solid symbols - constant load test; open symbols - constant deflection test.

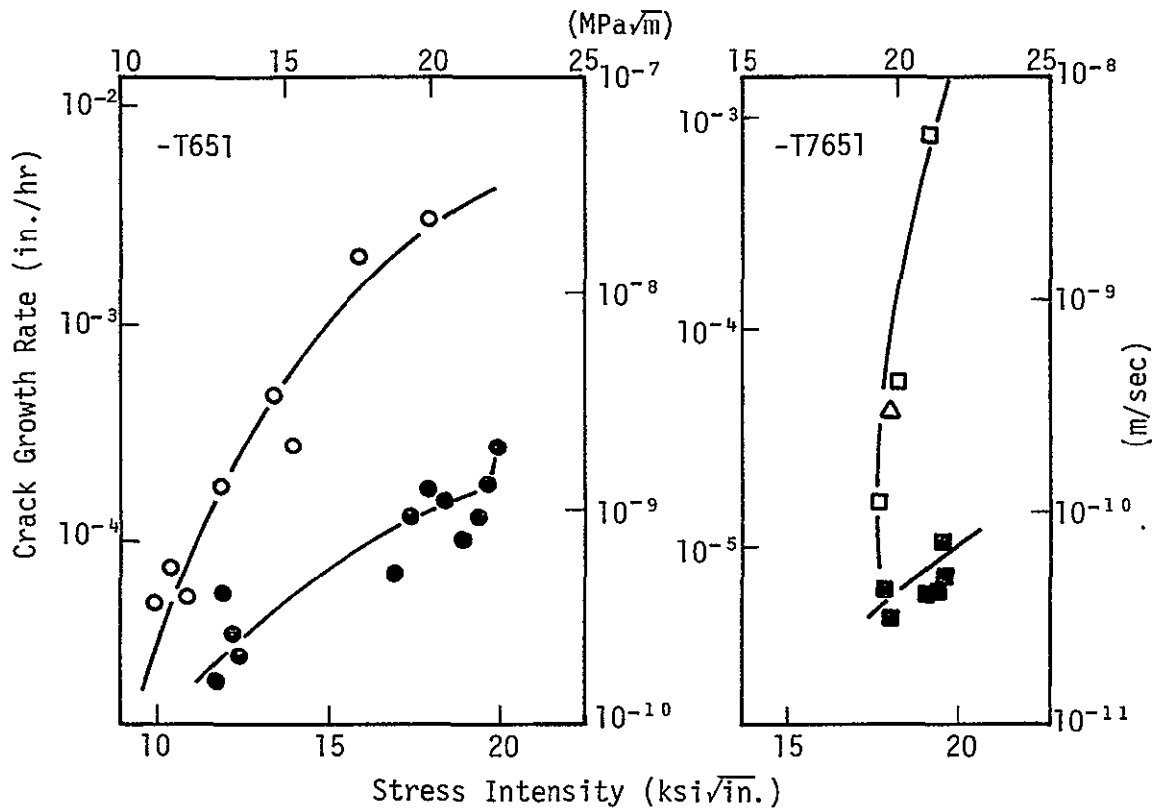

Figure A-3. V-K Plots for 7075-T651 and -T7641 Plate as Determined with S-L DCB Specimens Exposed to Synthetic Seawater

Solid symbols--constant load test; open symbols--constant deflection test. Triangle gives average crack velocity over the entire exposure period based on fracture surface measurement of crack length.

APPENDIX B

STRESS CORROSION TESTS OF NOMINAL TOUGHNESS 7475 PLATE

The 7475 plate fabricated for Contract NAS8-30890 did not meet the tentative minimum fracture toughness requirements published for this alloy (Ref 13). To determine whether greater fracture toughness and hence higher starting stress intensities for the constant deflection DCB specimen would affect stress corrosion crack growth rates, samples from 38-mm and 89-mm 7475 plate which had nominal fracture toughness were tested.

Experimental

Test materials included samples from a 38-mm-thick production 7475-T6 plate lot, aged to the -T76 and -T73 tempers, and a sample from an 89-mm 7475-T7351 plate acquired from KACC-Ravenswood plant. Mechanical properties and chemical composition of the test plates are shown in Table B-I. S-L DCB specimens were machined from these plates so that the crack plane would coincide with the center line of the plate. Specimen dimensions were modified somewhat to facilitate precracking and, hopefully, to allow valid K_{Ic} measurements in this high toughness material. Specimen beams were the maximum height allowed by the plate thickness. Specimens from the 38-mm plate were 19 mm wide and specimens from the 89-mm plates were 25 mm wide. All specimens were side grooved 20% (rather than 10%) and all were fatigue precracked. Specimens were taken from the 38-mm -T6 and -T76 plates as well as from the -T73 plate.

These DCB specimens were exposed to two environments: buffered salt chromate solution (0.6M NaCl - 0.02M $Na_2Cr_2O_7$ - 0.07M $NaC_2H_3O_2$ + $HC_2H_3O_2$ to pH 4) and marine atmosphere at Daytona Beach, Florida. Crack lengths were measured on the specimen sides with the aid of

a binocular microscope on an approximately logarithmic time scale, i.e.,; 1, 2, 4 days, 1 week, 2 weeks, 4 weeks, etc. The salt chromate test was terminated after 162 days. The marine atmosphere tests will be continued for at least 6 years.

In addition to the tests of precracked specimens, smooth specimens (3.175-mm-diameter tensile type) were exposed at appropriate stress levels to 3-1/2% NaCl alternate immersion (ASTM G44).

Results and Discussion

The results of the smooth specimen tests are shown in Table B-II. Specimens from the -T7651 plate survived longer than 30 days at 172 MPa (25 ksi) and specimens from the -T7351 plate survived more than 30 days at 310 MPa (45 ksi). These results indicate good stress corrosion resistance by conventional test methods.

Despite the precautions taken in preparing the DCB specimens, the bolts and/or threads could not support the loads required to mechanically "pop" a starter crack in most of the specimens. Consequently, most of the specimens were exposed with fatigue precracks at initial stress intensities somewhat less than K_{Ia} (the stress intensity for mechanical crack arrest) but still greater (36-39 MPa \sqrt{m}) than the 7475-T7351 plate reported in Reference 3 which had K_{Ia} values of 27 to 30 MPa \sqrt{m} . There was not enough material to determine actual fracture toughness of the 38-mm plate, but a comparison of the starting stress intensities (Table B-IV) for the DCB specimens suggests that K_{Ic} for the 38-mm plate was similar to that of the 89-mm plate.

Crack growth-time plots for these specimens are shown in Figures B-1 and B-2 for the salt-chromate and marine atmosphere

environments, respectively. A summary of starting stress intensities, residual stress intensities and crack growth is shown in Table B-III. Differences in crack growth for duplicate specimens are probably a reflection of differences in starting stress intensity and are minor except for the case of the 38-mm -T6 specimens in marine atmosphere. There were no noticeable incubation effects and self-loading was not yet apparent (at 6 months) in the marine atmosphere specimens.

Crack growth rate-stress intensity (V-K) plots are shown in Figures B-3 and B-4, and estimates of threshold stress intensity are given in Table B-IV. The 7475-T6 and -T76 samples seemed to be somewhat more susceptible to SC crack growth than the 7075-T651 and -T7651 materials reported in Reference 3. However, the nominal toughness 38-mm 7475-T73 plate had an apparent K_{ISCC} of 33 $\text{MPa}\sqrt{\text{m}}$ in salt-chromate and 35 $\text{MPa}\sqrt{\text{m}}$ marine atmosphere. These values are much higher than those reported for 7475-T7351 in Reference 3 (15.5 and 25 $\text{MPa}\sqrt{\text{m}}$ respectively for 32-mm plate). There was no apparent difference in SC crack growth behavior between the thicker 89-mm 7475-T73 and the thinner 38-mm plate in this study. The initial crack growth rates were slightly higher for the nominal toughness 7475-T73 but they decreased rapidly to the arbitrary 10^{-10}m/sec rate for K_{ISCC} so that the threshold stress intensity (K_{ISCC}) was actually higher than that reported in Reference 3.

Conclusions

7475-T73 plate having nominal (48 $\text{MPa}\sqrt{\text{m}}$) S-L fracture toughness had a short transverse threshold stress intensity (K_{ISCC}) of 33 and 35 $\text{MPa}\sqrt{\text{m}}$ in salt-chromate and marine atmosphere, respectively. This was much greater than lower strength, lower toughness 7075-T7351 plate of equivalent thickness. This 7475-T73 also had a

K_{ISCC} greater than that of 7049-T7351 and 7050-T7351 plate, as well as higher fracture toughness (K_{IC}), but the strength of the 7475 was somewhat lower. (Further work should be done to establish the effect of toughness on stress corrosion resistance).

Table B-I. Mechanical Properties and Chemical Composition
of Nominal Toughness 7475 Plate

Mechanical Properties of Test Plates

(Duplicate Long Transverse Tensiles)

<u>Thickness</u> <u>mm</u>	<u>Temper</u>	<u>TS,MPa</u> <u>(ksi)</u>	<u>YS,MPa</u> <u>(ksi)</u>	<u>Elongation</u> <u>%</u>
38	-T6	570 (82.6)	510 (78.9)	13
38	-T76	464 (67.3)	386 (56.0)	14
38	-T73	516 (74.9)	452 (65.5)	13
89	-T7351	470 (68.1)	393 (57.0)	14.5

Fracture Toughness of Test Plate

<u>Thickness</u> <u>mm</u>	<u>Temper</u>	<u>K_{IC}, MPa√m (ksi√in)</u>		
		<u>S-L</u>	<u>T-L</u>	<u>L-T</u>
89	-T7351	48.0 (43.5)*	55.5 (50.1)	69.9 (56.8)*

*K_{IQ}

Chemical Composition, Wt % (Quantometer)

	<u>Si</u>	<u>Fe</u>	<u>Cu</u>	<u>Mn</u>	<u>Mg</u>	<u>Cr</u>	<u>Zn</u>	<u>Ti</u>
38 mm	0.050	0.069	1.26	0.004	1.95	0.19	5.31	0.013
89 mm	0.050	0.068	1.30	0.003	1.96	0.21	5.36	0.012

Table B-II. Results of Smooth Specimen Stress
Corrosion Tests of Nominal Toughness
7475 Plate

3.175-mm tensile specimens in 3-1/2%
NaCl alternate immersion (ASTM G44).

<u>Thickness</u> <u>mm</u>	<u>Temper</u>	<u>Stress, MPa</u> <u>(ksi)</u>	<u>NF/NT - Failure Times</u>
38	-T76	310 (45)	4/4 - 21, 28, 31 & 48d
		241 (35)	3/3 - 37, 48 & 48d
		172 (25)	3/3 - 48, 48 & 67d
	-T73	379 (55)	4 ok 90d
		310 (45)	1/3 - 77d, 2 ok 90d
		241 (35)	3 ok 90d
89	-T73	310 (45)	3 ok 90d

Table B-III. Summary of Stress Corrosion Crack Growth for Nominal Toughness
7475 Plate

S-L DCB Specimens.

Thickness mm	Temper	Specimen	Salt Chromate ^a			Marine Atmosphere ^b		
			Starting K ^c MPa√m	Residual K MPa√m	Crack Growth mm	Starting K ^c MPa√m	Residual K MPa√m	Crack Growth mm
38	-T651	1	35.4	5.0	58.9	17.2	5.5	34.8
38		2	32.0	5.1	54.6	24.4	5.6	45.5
38	-T7651	1	30.7	18.9	11.7	38.2	24.7	8.6
38		2	25.7	16.8	9.7	35.4	24.3	7.1
38	-T7351	1	36.2	34.6	0.8	37.1	33.7	1.8
38		2	35.8	31.4	2.3	38.9	35.3	1.8
89	-T7351	1	36.6	35.1	1.0	37.2	33.4	2.8
89		2	NT	-	-	38.0	34.2	2.8

^a162 days exposure--final measurements were taken from fracture surface.

^b202 days exposure--test continuing.

^c K_{Ia} --all specimens were fatigue precracked but not all could be mechanically "popped" to K_{Ia} .

Table B-IV. Estimated S-L Threshold Stress Intensity*
 (K_{Isc}) for Nominal Toughness 7475 Plate
 SL-DCB Specimens.

Thickness, mm	Temper	K_{Isc} , MPa \sqrt{m}	
		Salt Chromate	Marine Atmosphere, 6 Mo.
38	-T651	<4	<5
38	-T7651	<16	<24
38	-T7351	~36	~35
89	-T7351	~33	~35

*At 1×10^{-10} m/sec crack growth rate.

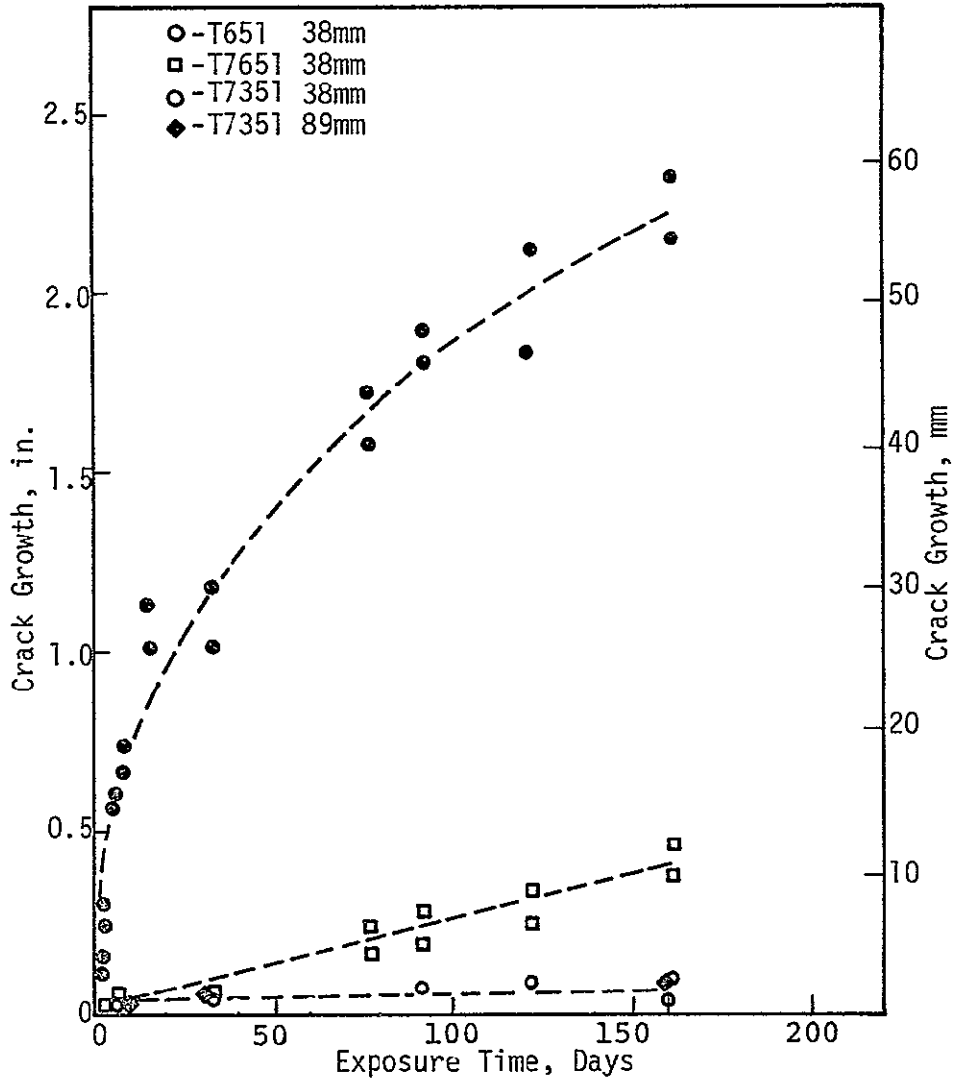

Figure B-1. Crack Growth in DCB Specimens from 7475 Plate Exposed 162 Days to Salt-Chromate: S-L Orientation, Fatigue Precrack (Duplicate Specimens)

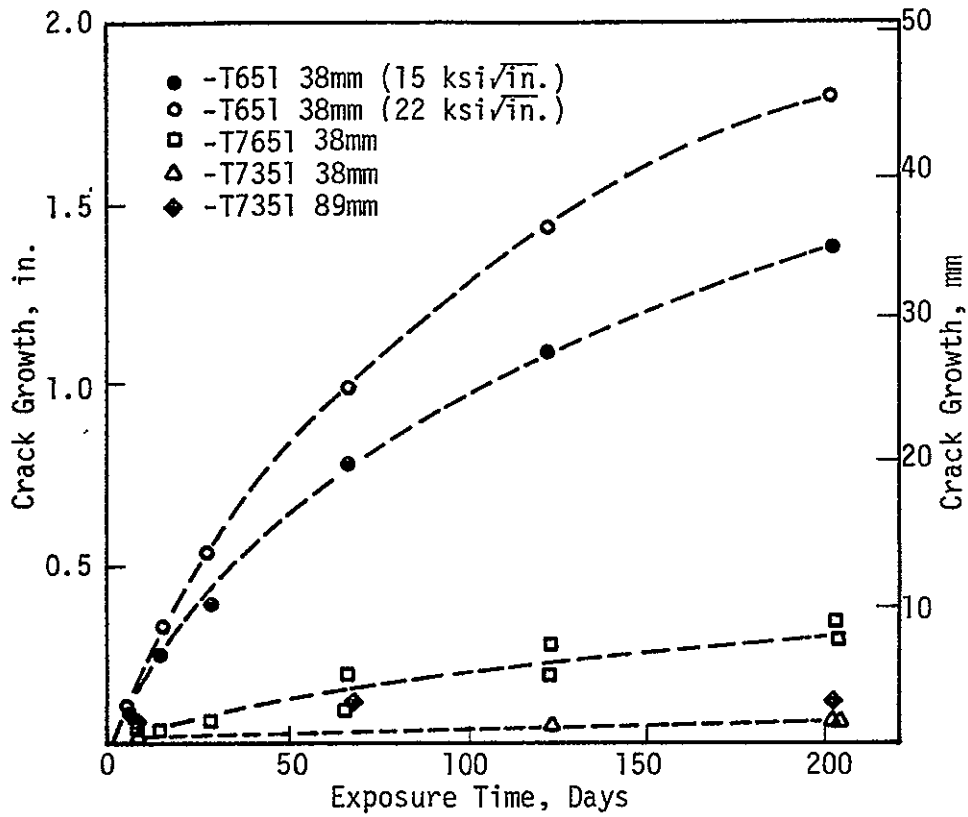

Figure B-2. Crack Growth in DCB Specimens from 7475 Plate Exposed 202 Days to Marine Atmosphere at Daytona Beach: S-L Orientation, Fatigue Pre-cracked, Duplicate Specimens

Note that -T651 specimens were started at different stress intensities, both below K_{IC} .

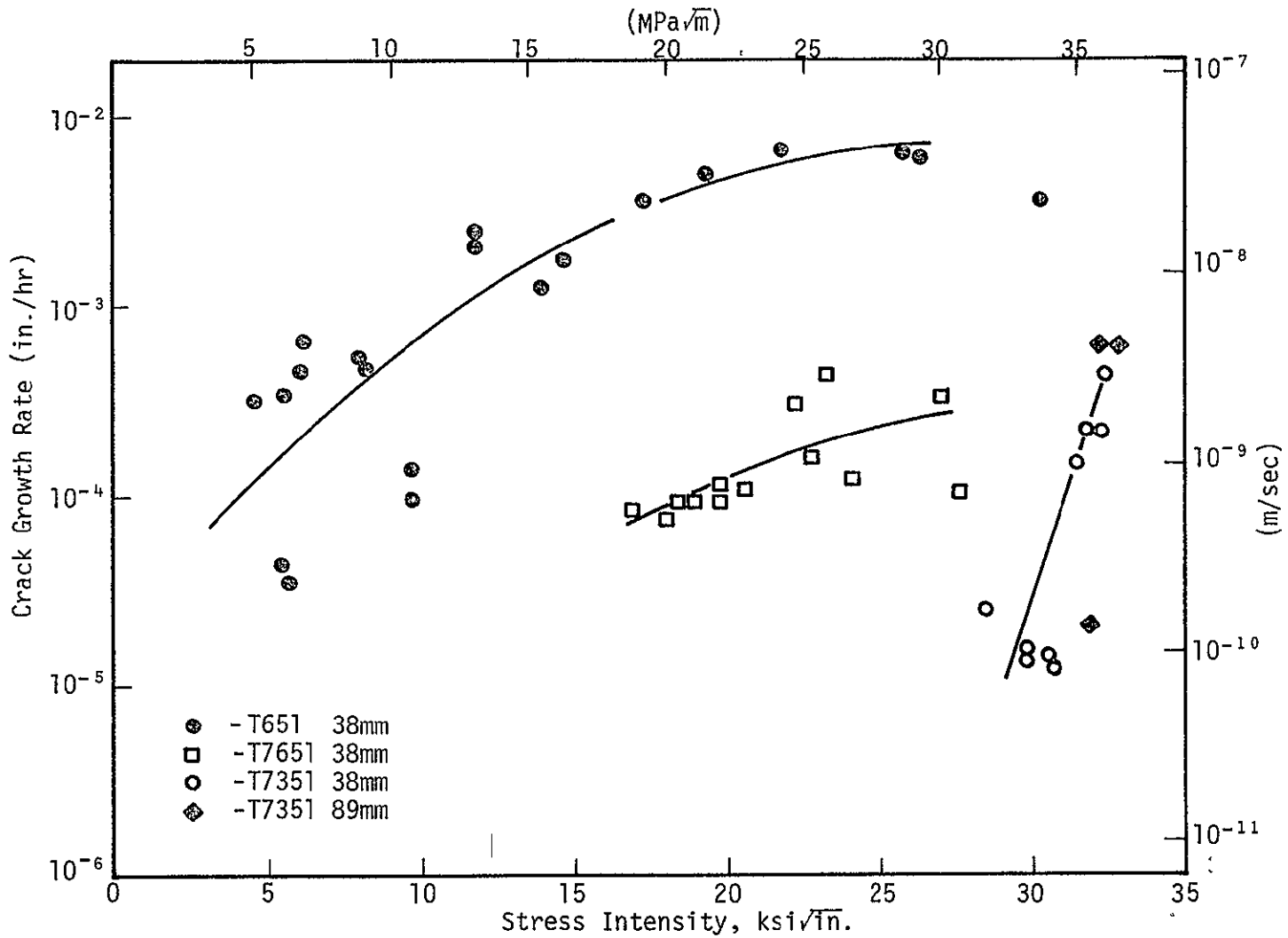

Figure B-3. V-K Plots for DCB Specimens from 7475 Plate Exposed 162 Days to Salt-Chromate: S-L Orientation, Fatigue Precracked (Duplicate Specimens)

7475 Plate Exposed 162 Days to Salt-Chromate
 S-L Orientation, Fatigue Precracked
 Duplicate Specimens

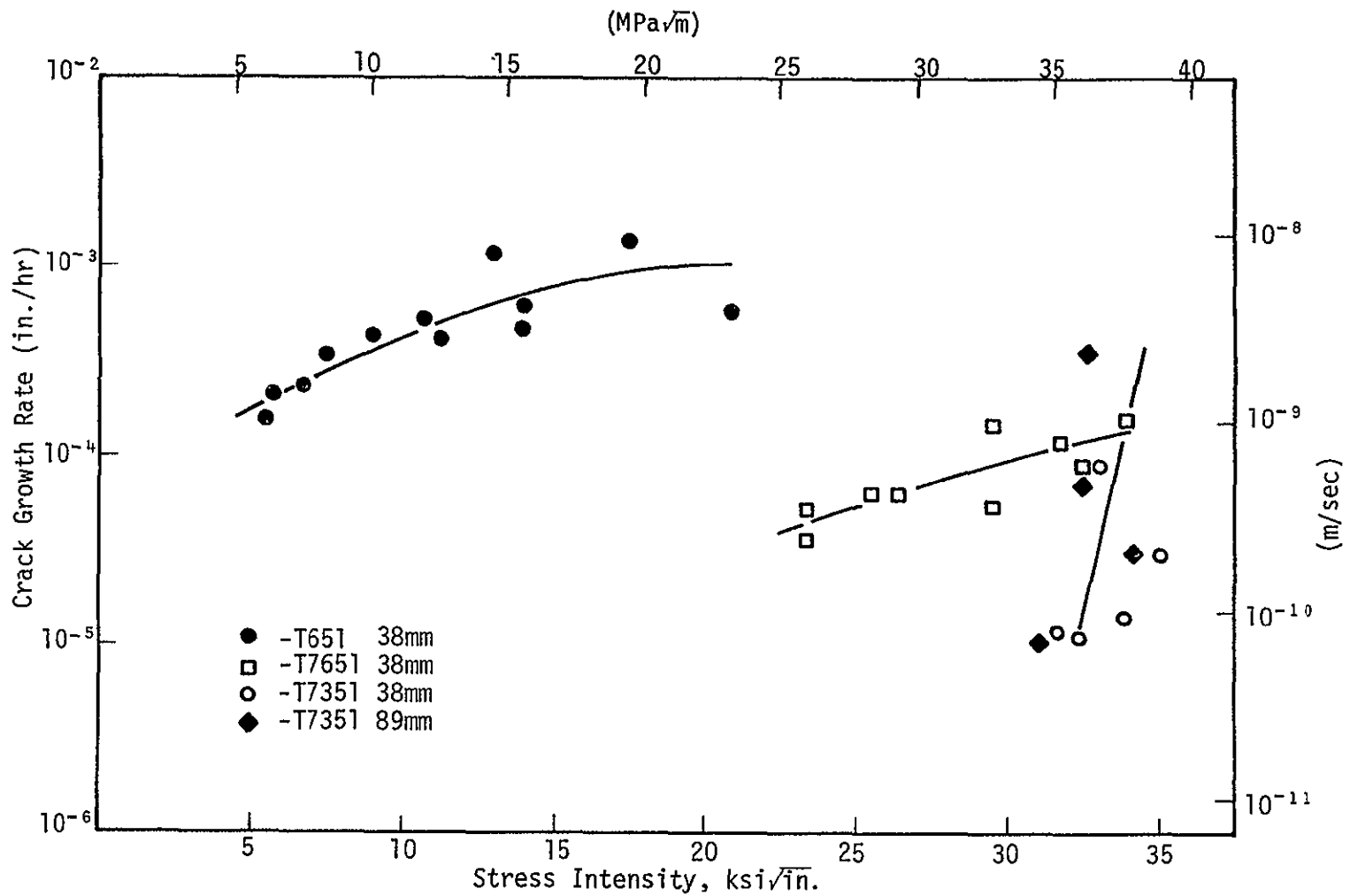

Figure B-4. V-K Plots for DCB Specimens from 7475 Plate Exposed 202 Days to Marine Atmosphere: S-L Orientation, Fatigue Precracked (Duplicate Specimens)