

General Disclaimer

One or more of the Following Statements may affect this Document

- This document has been reproduced from the best copy furnished by the organizational source. It is being released in the interest of making available as much information as possible.
- This document may contain data, which exceeds the sheet parameters. It was furnished in this condition by the organizational source and is the best copy available.
- This document may contain tone-on-tone or color graphs, charts and/or pictures, which have been reproduced in black and white.
- This document is paginated as submitted by the original source.
- Portions of this document are not fully legible due to the historical nature of some of the material. However, it is the best reproduction available from the original submission.

NGR-15-005-11A

(NASA-CR-156940) CALIBRATION OF
LONGWAVELENGTH EXOTECH MODEL 20-C
SPECTRORADIOMETER (Instituto de Pesquisas
Espaciais, Sao Jose) 30 p HC A03/MF A01

N78-28414

Unclas
CSCL 14B G3/35 27967



RECEIVED BY
NASA STI FACILITY
DATE: 8-17-78
DCAF NO. 602949
PROCESSED BY
 NASA STI FACILITY
 ESA-SDS AIAA

1. Classification INPE-COM.10/PE C.D.U.: 621.3ASR: 631	2. Period	4. Distribution Criterion internal <input type="checkbox"/> external <input checked="" type="checkbox"/>
3. Key Words (selected by the author) - Calibration Spectroradiometer - Longwavelength Spectroradiometer - Calibration-Wavelength - Calibration-Spectral Radiance - Exotech Model 20C Spectroradiometer		7. Revised by <i>Dale Simonich</i> Dale Simonich
5. Report No INPE-1296-PE/114	6. Date June, 1978	9. Authorized by <i>Narada</i> Nelson de Jesus Parada Director
8. Title and Sub-title CALIBRATION OF LONGWAVELENGTH EXOTECH MODEL 20C SPECTRORADIOMETER		11. No of Copies 19
10. Sector	Code	
12. Authorship R. Kumar, B. Robinson and I. Silva		14. No of Pages 29
13. Signature of the responsible <i>Ravindra Kumar</i>		15. Price
16. Summary/Notes A brief description of the Exotech model 20-C field spectroradiometer which measures the spectral radiance of a target in the wavelength ranges 0.37 to 2.5 μm (short wavelength unit), 2.8 to 5.6 μm and 7.0 to 14 μm (long wavelength unit) is given. Wavelength calibration of long wavelength unit was done by knowing the strong, sharp and accurately known absorption bands of polystyrene, atmospheric carbon dioxide and methyl cyclohexane (liquid) in the infrared wavelength region. The spectral radiance calibration was done by recording spectral scans of the hot and the cold blackbodies and assuming that spectral radiance varies linearly with the signal.		
17. Remarks Being Considered for Publication in Applied Optics.		

INDICE

	Page
LIST OF FIGURES	<i>iv</i>
LIST OF TABLES	<i>v</i>
ABSTRACT	1
I - INTRODUCTION	1
II - DESCRIPTION OF THE INSTRUMENTATION AND EQUIPMENT	3
III - FUNCTIONAL DESCRIPTION	4
IV - CALIBRATION OF THE LONG WAVELENGTH UNIT	6
REFERENCES	13

LIST OF FIGURES

- Figure 1** Schematic of telescope showing viewing arrangement in $3/4^\circ$ F.O.V.
- Figure 2** Radiation sensing system for the longwavelength unit.
- Figure 3** Wavelength calibration for Indium Antimonide channel.
- Figure 4** Wavelength calibration for Mercury Cadmium Telluride channel.
- Figure 5** Comparison of emittance of paints in Indium Antimonide channel.
- Figure 6** Comparison of emittance of paints in Mercury Cadmium Telluride channel.
- Figure 7** Blackbody.
- Figure 8** Theoretical and computed values of the spectral radiance and temperature in Indium Antimonide channel.
- Figure 9** Theoretical and computed values of the spectral radiance and temperature in Mercury Cadmium Telluride channel.

LIST OF TABLES

Table I Specifications of the Exotech Model 20 C Spectroradiometer.

Table II Reference Wavelengths for Calibration.

CALIBRATION OF LONGWAVELENGTH EXOTECH
MODEL 20C SPECTRORADIOMETER

R. Kumar, B. Robinson and L. Silva

ABSTRACT

A brief description of the Exotech model 20-C field spectroradiometer which measures the spectral radiance of a target in the wavelength ranges 0.37 to 2.5 μm (short wavelength unit), 2.8 to 5.6 μm and 7.0 to 14 μm (long wavelength unit) is given. Wavelength calibration of long wavelength unit was done by knowing the strong, sharp and accurately known absorption bands of polystyrene, atmospheric carbon dioxide and methyl cyclohexane (liquid) in the infrared wavelength region. The spectral radiance calibration was done by recording spectral scans of the hot and the cold blackbodies and assuming that spectral radiance varies linearly with the signal.

I - Introduction

In research related to remote sensing of earth resources, the electromagnetic energy reflected and/or emitted from the earth's surface is measured and attempts are made to determine the unique relations between the reflected and/or emitted spectra and the target area¹. In response to increasing interest in the remote sensing programs, a number of satellite programs have been started.

R. Kumar is with the Instituto de Pesquisas Espaciais (INPE/CNPq), Department of Space Systems, Division of Information Sciences, 12.200 São José dos Campos, SP, Brazil; the other authors are with the Laboratory for Applications of Remote Sensing, Purdue University, W. Lafayette, IN.

Thus, an enormous wealth of data is available for earth resources studies from cameras, and aircraft & satellite, optical-mechanical scanners. There have been a large number of laboratory studies of the reflectance of individual leaves, soil samples, rock samples, etc.. Such techniques have been used effectively, but the resulting spectra lack the interrelationships between green leaves, dry brown leaves, the soil, shadows etc., for the entire scene, as measured by an airborne remote sensing system? That is why since the inception of the Laboratory for Applications of Remote Sensing (LARS), Purdue University, its remote sensing researchers felt that a field spectroradiometer would add a useful dimension to surface observations connected with overflights³.

Recently Longshaw⁴ (1974) developed an analytical approach to field spectroscopy for multispectral remote sensing. He presented application problems associated with some of the existing reflectance data and pointed out the geometrical considerations necessary for field spectroscopy. He used a field spectroradiometer made by Spectral Data Corporation, for the measurement of bi-directional reflectance of rock types in the wavelength range of 0.4 to 1.0 μm .

Robinson and Silva⁵ have pointed out that the design and implementation of a system for the acquisition of calibrated visible and infrared spectral data, for use in remote sensing research, presents some challenging problems. The first problem is the selection of an instrument suitable under field conditions. A circular - variable - filter type instrument was specified, because of its potential as a rugged instrument, which is relatively insensitive to vibration and bumps. In addition, the system should be developed so that the instrument can quickly assume a useful measurement position in a wide range of remote measurement sites. The components chosen here were the frequency controlled portable generator, the instrument van, and the mobile aerial tower. Other

problems include the design of procedures and devices for field calibration of the instrument and electronic data logging and handling.

During the summer of 1970, an extended wavelength instrument (Exotech Model 20 B) was tested and evaluated by LARS personnel as part of a cooperative program with the USDA facility at Weslaco, Texas¹. In summary, the instrument features refractive fore-optics and covers the wavelength range from 0.4 to 2.5 μm (short wavelength head) and from 2.8 to 15 μm (long wavelength head). Four detectors with Joule-Thompson cooling, circular-variable- filter (CVF) wheel spectrum scanning, to 30 second adjustable spectral scans and adjustable field of view, $3/4$ to 15° , are features of this instrument.

Based on this experience, a modified instrument, the Exotech Model 20 C, was designed and constructed to LARS specifications. This instrument features a reflective fore-optics system (Newtonian telescopes), a field calibration system, and an inline sighting system.

In addition, several electronic improvements and an electrical view angle adjustment feature have been included. The purpose of this paper is to give a brief description of the instrument and procedures used for its field calibration.

II - Description of the Instrumentation and Equipment

The Exotech Model 20 C is a rugged field instrument which uses four circular-variable- filters to provide spectral resolution of approximately 2%. The instrument may be operated as two separate units. The short wavelength (SWL) unit is responsive to radiation in the wavelength range 0.38 to 2.5 μm and the long wavelength unit (LWL) is responsive to radiation in the wavelength ranges 2.8 to 5.6 and 7.0 to

14 μm .

Figs. 1 and 2 illustrate the radiation sensing and gathering systems for the LWL unit. The combined gathering and sensing system is referred to as the optical head. The SWL and LWL optical heads are functionally identical, except for the inclusion of a solar reference port on the SWL head. The main specifications of the spectroradiometer are given in Table I.

III - Functional Description

A. Long Wavelength Unit

The radiation from the target scene is folded into the radiation processing system by the folding mirror either directly (15° FOV) or from the primary mirror of the Newtonian telescope ($3/4^\circ$ FOV) (Fig. 1). When the selecting mirror is rotated 90° , the radiation from the target scene is reflected directly into the instrument, producing the 15° field of view determined by the refracting optics/detector combination.

When the folding mirror is in the $3/4^\circ$ FOV position, the mirror on the back face of the folding mirror directs radiation from the target scene into the boresighting telescope for sighting and photography. Since the boresighting telescope uses radiation which would normally be lost due to the occulting of the folding mirror, this feature does not affect the efficiency of the radiometer.

The folded radiation enters the radiation processing system and is directed by the chopper wheel alternately to the two CWF wheels. Simultaneously, radiation from the heated reference blackbody is being directed alternately to the two CWF wheels (Fig. 2).

When the incoming radiation is being reflected onto the indium-antimonide detector, the mirror's back side of

the chopper blade reflects the radiation from the reference surface onto the mercury-cadmium-telluride detector. Similarly, when the incoming radiation is being passed through a space in the chopper wheel to the indium-antimonide detector, the radiation from the reference surface is passed through to the mercury-cadmium-telluride detector. Similar processing is performed in the short wavelength unit.

KRS-5 (thallium bromide-iodide) optics image the scene on the CVF wheels and refocus the image onto the detector.

One CVF wheel is turned at a constant speed by a Siemens brushless DC motor and the shaft of the other CVF 15 driven with a non-slip belt system. The speed of the DC motor is selectable on the front panel of the electronic processing and control circuitry. The CVF position is indicated by an optical shaft angle encoder which produces 1000 pulses per revolution. These pulses are the basis of the wavelength calibration scheme. These pulses are also integrated in the electronic processing and control circuitry module to produce a ramp suitable for driving X-Y plotters or recording CVF position information on strip chart recorders.

Each of the detectors is cooled with a Joule-Thompson cryostat using high pressure nitrogen. The output of each detector is amplified by a preamplifier located close to the detector. The amplified signals are then synchronously demodulated in the electronic processing and control circuitry module. The demodulated signals are amplified and filtered for delivery to the data acquisition system.

B. Short Wavelength Unit.

The short wavelength unit is functionally identical to the long wavelength unit except for the following:

1. The silicon detector is not cooled.
2. The reference blackbody is not heated.

A solar reference port is positioned so that radiation from this diffusely translucent (opal glass) plate may be directed into the detectors by a mirror, whose position is controlled by a knob on the front panel of the electronic processing and control module. This knob allows selection of the target scene, the solar port or an automatic mode which causes the instrument to alternate between the two, every two scans.

C. Accessory Equipment

The LARS instrument van³ has been modified to accommodate the Exotech Model 20 C Spectroradiometer. To improve the system performance, the Ampex SP-300 tape recorder will eventually be replaced with an on-line digital data acquisition system which will also multiplex housekeeping and meteorological data. All electrical power in the instrument van is provided by the 6.5 KVA electronically controlled Kohler portable motor generator. The LARS Hi-Ranger mobile aerial tower is used to lift the optical heads to the desired position relative to the target scene. The optical heads may be lifted to a height of 15.3 meters above the ground and may be suspended as far as 6.4 meters from the edge of the Hi-Ranger at a height of 9.15 meters.

Further details of the LARS Extended Wavelength Spectroradiometer can be found in Kumar and Silva (1973)⁶ and Robinson et al⁷.

IV - Calibration of the Long Wavelength Unit

Since the electronics and optics of the instrument are subjected to both mechanical and thermal stresses under field conditions, on-site calibration is necessary. On-site procedures must be simple, and accurate, as well as quickly and easily performed.

A. Wavelength Calibration

Wavelength Calibration is performed by referring to certain emission and absorption lines^{8,9,10}. Since the range of wavelengths of the radiant power arriving at the detectors depends on the size and angle of the beam as it passes through the circular variable filter (CVF), it is necessary to completely fill the field of view of the instrument during wavelength calibration. This fact is carefully considered in each wavelength calibration procedure.

As described in Sec. III, an optical shaft angle encoder produces 1000 pulses for each CVF revolution. These pulses are assigned to wavelengths by the following procedure developed by Mr. R.D. Haselby¹¹.

At the end of each rotation of the CVF, the optical encoder generates a reset pulse. This pulse is used to reset the programmable counter in the Data Acquisition Control Module. The wavelength of the Spectral (absorption or emission) is recorded when it splits symmetrically. This technique is superior to pulse riding techniques—especially when absorption and emission bands are relatively broad and weak.

The wavelength calibration for both the thermal channels (2.8 to 5.6 μm and 7.0 to 14.0 μm) was done by finding the pulse number corresponding to the strong, sharp and accurately known absorption bands of polystyrene, atmospheric carbon dioxide and methyl-cyclohexane (liquid) (see Table II).

It can be seen in Fig. 3 and 4 that the pulse number versus wavelength curve is almost a straight line. A least-square line was fitted to the data for each filter wheel. The results of the analysis are given in Table II.

B. Spectral Radiance Calibration

The spectroradiometer alternatively looks at

the target and the reference blackbody. At wavelength λ , the voltage response, S , of the spectroradiometer is given by:

$$S = K_1(\lambda) [L_{\lambda,t}(\lambda, t) - K_2(\lambda) L_{\lambda,r}(\lambda, T_r)] \quad (1)$$

where

$K_1(\lambda)$ = instrument transfer function

$K_2(\lambda)$ = constant for the reference blackbody

$L_{\lambda,t}$ = spectral radiance of the target

$L_{\lambda,r}$ = spectral radiance of the reference blackbody

Equation (1) assumes that S is linearly related to $L_{\lambda,t}$ for a given value of $L_{\lambda,r}$ at any wavelength. For a blackbody, eq. (1) reduces to

$$S = K_1(\lambda) [L_{\lambda,b}(\lambda, T) - K_2(\lambda) L_{\lambda,r}(\lambda, T_r)] \quad (2)$$

where

$L_{\lambda,b}(\lambda, T)$ = spectral radiance of the blackbody at wavelength λ and temperature T

The spectral blackbody radiance at temperature, T , and wavelength, λ , is given by Planck's Law with usual notations as follows:

$$L_{\lambda,b}(\lambda, T) = \frac{2hc^2}{\lambda^5 [\exp(hc/kT) - 1]} \quad (3)$$

or

$$T = \frac{hc}{\lambda k (\log_e (1 + \frac{2hc^2}{\lambda^5 L_{\lambda,b}(\lambda, T)}))} \quad (4)$$

A copper cone having an apex angle of 15° and maximum diameter of about 16.2 cm was chosen as the blackbody. Copper was chosen because it is a good conductor of heat and thus can be maintained at an essentially uniform temperature. It was decided to paint the copper cone inside with such a paint as to increase the normal spectral emittance of the cone. For conducting emittance tests, the following paints were selected as these have been reported as having high spectral normal emittance in the wavelength range of our interest, 2.8 to 14 μm .

1. Eppley - Parson's Optical Black Lacquer
2. Krylon Flat Black Enamel No. 1602
3. Krylon Glossy Black Enamel No. 1601
4. 3M Velvet Black 101 - C 10

Comparative tests of normal spectral emittance of these paints were conducted by painting each of them on a 6" by 6" area of a copper sheet. The relative spectral emittances of the samples were measured using the Spectroradiometer-Exotech Model 20 C ($3/4^\circ$ FOV). Each sample was heated to $50 \pm 0.02^\circ\text{C}$ so that the energy emitted by the sample was considerably greater than the energy reflected from it. The responses are shown in Fig. 5 and 6 respectively. It is clear from Fig. 5 and 6 that Parson's Optical Black Lacquer had the highest response and, hence, the greatest emittance at most of the wavelengths. In addition, the Eppley Laboratory confirmed the uniformity of the emittance of Parson's Black Lacquer with wavelength and it was found to be almost as good as gold black (heavy coat). In the British Meteorological Service, the emittance of the paint at 25°C (i.e., wavelength maximum of 10 μm) established¹² at 0.98. For this value, the theoretical apparent emittance of a cone of 15° lies¹³ between 0.995 and 1.

To fabricate a field calibration source a copper cone is painted with Parson's Optical Black Lacquer

and fitted into a fiberglass covered foam box of about 16" in length, 10" width and 14" height, as shown in Fig. 7. In field operations, the foam box is filled with water, which is constantly stirred by a paint mixer, driven by an electrical motor, to maintain the water at a uniform temperature. The water is heated and cooled to attain the desired temperature of the cone. It has been found that the cone can be kept at a uniform temperature (within 0.2° C) and held constant (with no attempt of external control, the temperature of the cone dropped less than 1° C per hour). Two such blackbodies are used in field experiments. One, the hot blackbody, is kept at above ambient temperature and the other, the cold blackbody, is kept at below the ambient temperature.

It can be seen from eq. (1) that the spectral radiance varies linearly with the signal for a given reference blackbody temperature at each wavelength. Calibration is accomplished in the field with the spectroradiometer mounted, ready for use, on the mobile aerial tower bucket. The internal reference blackbody temperature is so chosen as to be a few degrees above the highest temperature which the instrument is expected to reach during the heat of the day. This is necessary since the temperature of the blackbody is kept constant by the use of a heater. The hot blackbody temperature and the cold blackbody temperature are chosen 2 or 3° C above and 2 or 3° C below the highest and lowest expected temperatures of the targets (i.e., plants, soils, etc.) respectively. The cold blackbody is held snug against the opening of the optics of the spectroradiometer which is set to the 15° field of view. Then several spectral scans of the blackbody are performed. The process is repeated for the hot blackbody. Data are recorded on the same analog tape as the experiment data and are later processed digitally. The instrument is recalibrated at about half an hour intervals and whenever any parameter of the instrument is altered. The temperature of the target, T, is calculated by using eqs. (2)

to (4).

Experiments were done to establish the linearity of the signal with the spectral radiance of the blackbody, as given by eq. (2). From the spectral scans of the blackbody at several temperatures, this assumption was found to be valid within the accuracy of experimental measurements. Further details of this can be found in Kumar and Silva (1973)⁶.

To determine the accuracy of the calibration, a spectral scan of the blackbody was performed at temperatures of 17.5^o C, 23.1^o C and 37.6^o C beside a corn field on the Purdue University Agronomy Farm. The blackbody with a measured temperature of 23.1^o C was treated as a target at unknown temperature and its spectral radiance was computed by linear interpolation of the blackbody spectral radiance at 17.5^o C and 37.6^o C and this computed spectral radiance was used to calculate the corresponding temperature, given by eq. (4). Figs. 10 and 11 compare the theoretical (i.e., blackbody spectral radiance at 23.1^o C given by Planck's Law - eq. (3) and computed values of the spectral radiance and temperature of the target, in indium antimonide and mercury cadmium telluride channels, respectively. Characters 1 and 2 indicate the theoretical and computed values of the spectral radiance respectively. Characters 3 and 4 indicate computed values of the temperature measured using a precision thermometer and the spectral radiance temperatures respectively. The asterisk indicates agreement within the smallest unit of the scale shown in the figures. It can be seen, from Figs. 8 and 9, that, except for the wavelength range 2.7 to 3.4 μm , the temperature usually computes to within 0.5^o C and the spectral radiance usually computes to within ± 1 percent of the full scale value. The high departure from theory in the wavelength range 2.7 to 3.4 μm is due to the relatively small values of spectral radiance (less than 100 microwatts/sq. cm./steradian/micrometer) and hence, low signal to noise ratio in this wavelength region.

This work was supported by the National Aeronautics and Space Administration (NASA) under grant nº 15-005-112.

The authors gratefully acknowledge the assistance of Mr. R.D. Haselby and Mr. W.R. Simmons with this work. We are indebted to Dr. Nelson de Jesus Parada (Director) and Dr. Celso de Renna e Souza, of the Instituto de Pesquisas Espaciais (INPE), for providing us with facilities for completion of this work at INPE.

References

1. R.W. Leamer, V.I. Myers, and L.F. Silva, Rev. Sci. Instrum. 44, 661 (1973).
2. L. Silva, R. Hoffer and J. Cipra, in Proceedings of the Seventh International Symposium on Remote Sensing of Environment, Environmental Research Institute of Michigan, Ann Arbor, MI, pp. 1509-1518, 1971.
3. Laboratory for Applications of Remote Sensing, "Remote Multispectral Sensing in Agriculture", Annual Report, Purdue University, W. Lafayette, Indiana, 1968.
4. T.G. Longshaw, Appl. Opt. 13, 1486 (1974).
5. B.F. Robinson and L.F. Silva, "A Visible and Infrared Spectroradiometer System for Remote Sensing Field Research" Laboratory for Applications of Remote Sensing, Purdue University, W. Lafayette, Indiana (In Preparation).
6. R. Kumar and L. Silva, LARS Information Note 072473, Laboratory for Applications of Remote Sensing, Purdue University, W. Lafayette, Indiana, 1973.
7. B. Robinson, L. Silva, R. Haselby, R. Kumar, W. Simmons, N. Bauer, and J. Cipra, LARS Information Note 040173, Laboratory for Applications of Remote Sensing, Purdue University, W. Lafayette, Indiana (In Preparation).
8. E.K. Plyer and C.W. Peters, J. Res. Nat. Bur. Stand. 45, 462 (1950).
9. Calibrated Polystyrene Film, Prepared by Beckman's Instruments, Inc., as well as Perkin-Elmer, Inc.

10. E.K. Plyer, L.R. Blaine, and M. Nowak, J. Res. Nat. Bur. Stand. 58, 195 (1957).
11. R.D. Haselby, LARS Technical Memorandum T-11, Laboratory for Applications of Remote Sensing, Purdue University, W. Lafayette, Indiana, 1973.
12. IGY Instruction Manual, Part VI, Radiation Instruments and Measurements (Pergamon Press, New York, 1958), p. 436.
13. E.M. Sparrow and V.K. Jonsson, J. Opt. Soc. Am. 53, 816 (1963).

Table I - Specifications of the Exotech Model 20 C Spectroradiometer

Field of View	0.75° or 15° remotely selectable
Short Wavelength Unit (SWU)	Wavelength Range (µm): 0.37 to 0.7 µm (detector: Silicon), 0.7 to 1.3 µm (detector: Lead Sulfide), 1.3 to 2.5 µm (detector: Lead Sulfide)
Long Wavelength Unit (LWU)	Wavelength Range (µm): 2.8 to 5.6 µm (detector: Indium Antimonide), 7.0 to 14.0 (detector: Mercury Cadmium Telluride)
Spectral Scan Rate	Selectable 0.5, 1, 2, 4, 10 and 30 seconds per scan
Spectral Resolution	SWU: 2.5% LWU: 2%
Half Bandwidth	17 nanometers (visible) 32 nanometers (near infrared)
Dynamic Range	Linear dynamic range of the system is at least 10 ⁴
Wavelength Accuracy	± 0.2% of value
Noise Equivalent Spectral Reflectance Factor	At 0.6 µm, 1.0 µm and 1.6 µm (less than 4%)
Weight	SWU Optical Head: 32 Kg, LWU Optical Head: 30 Kg Direct Mounting Plate 14.5 Kg
Power Requirements	150 watts, 115 volts ± 20% Hz ± 1 Hz

TABLE II - Reference Wavelengths for Calibration

Indium Antimonide Channel		Mercury Cadmium Telluride Channel	
Wavelength (μm)	Substance Used	Wavelength (μm)	Substance Used
3.3033	Polystyrene, ref. [8]	7.268	Methyl Cyclohexane, ref. [8]
3.4188	Polystyrene, ref. [8]	8.661	Polystyrene, ref. [9, 10]
3.507	Polystyrene, ref. [8]	9.3536	Polystyrene, ref. [9]
4.258	Carbon dioxide, ref. [8]	9.725	Polystyrene, ref. [9]
5.143	Polystyrene, ref. [9]	11.027	Polystyrene, ref. [9]
5.3447	Polystyrene, ref. [9]	11.475	Methyl Cyclohexane, ref. [8]
		11.862	Methyl Cyclohexane, ref. [9]

Avg. $|\lambda - \lambda_p| = 0.014 \mu\text{m}$
 Max. $|\lambda - \lambda_p| = 0.027 \mu\text{m}$

Avg. $|\lambda - \lambda_p| = 0.007 \mu\text{m}$
 Max. $|\lambda - \lambda_p| = 0.015 \mu\text{m}$

where

λ_p = predicted value of the wavelength by a straight line least square fit
 λ = experimentally determined value of wavelength

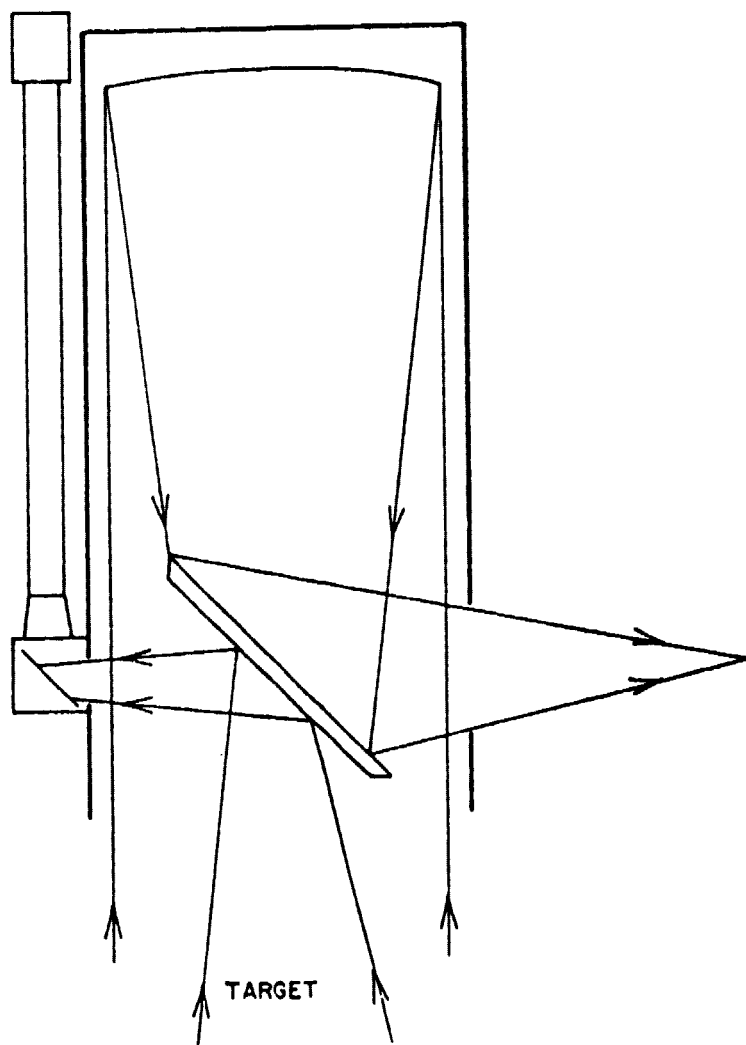

Figure 1 - Schematic of Telescope Showing Viewing Arrangement in 3/4° F.O.V.

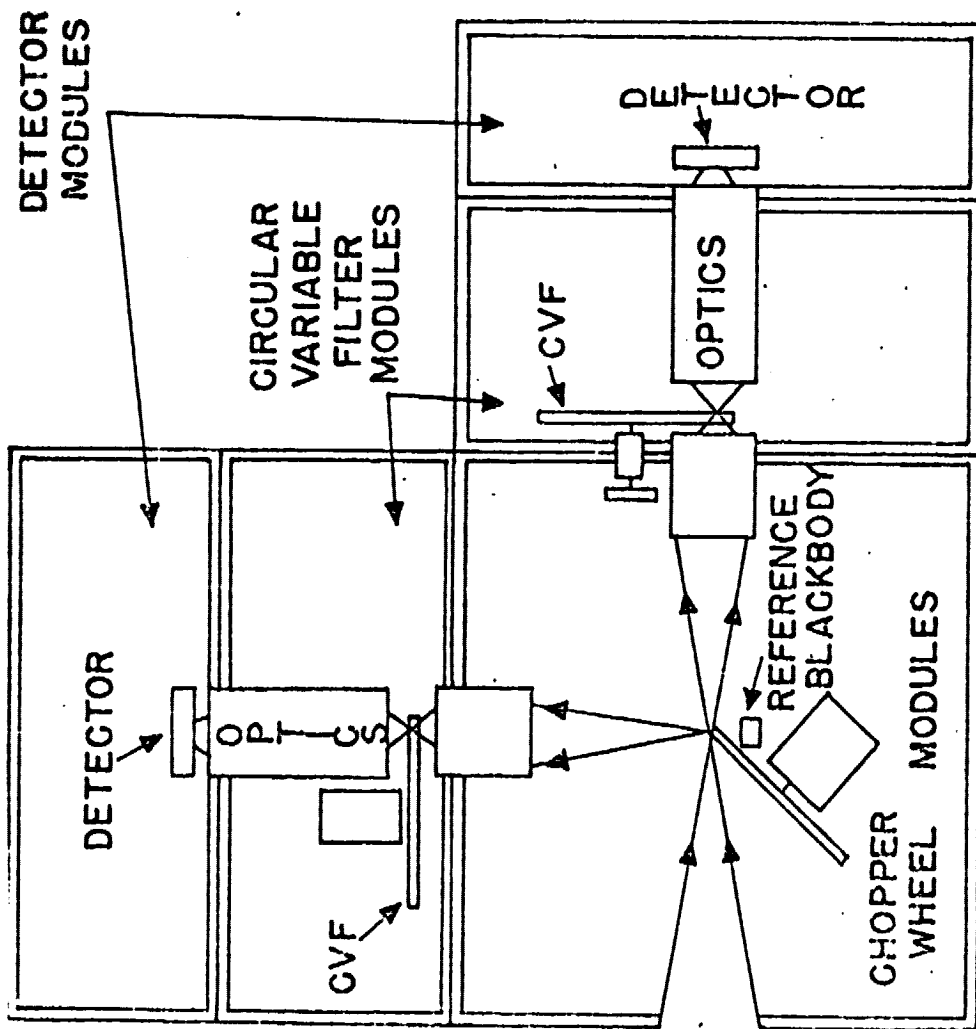

Figure 2 - Radiation Sensing System for the Longwavelength Unit.

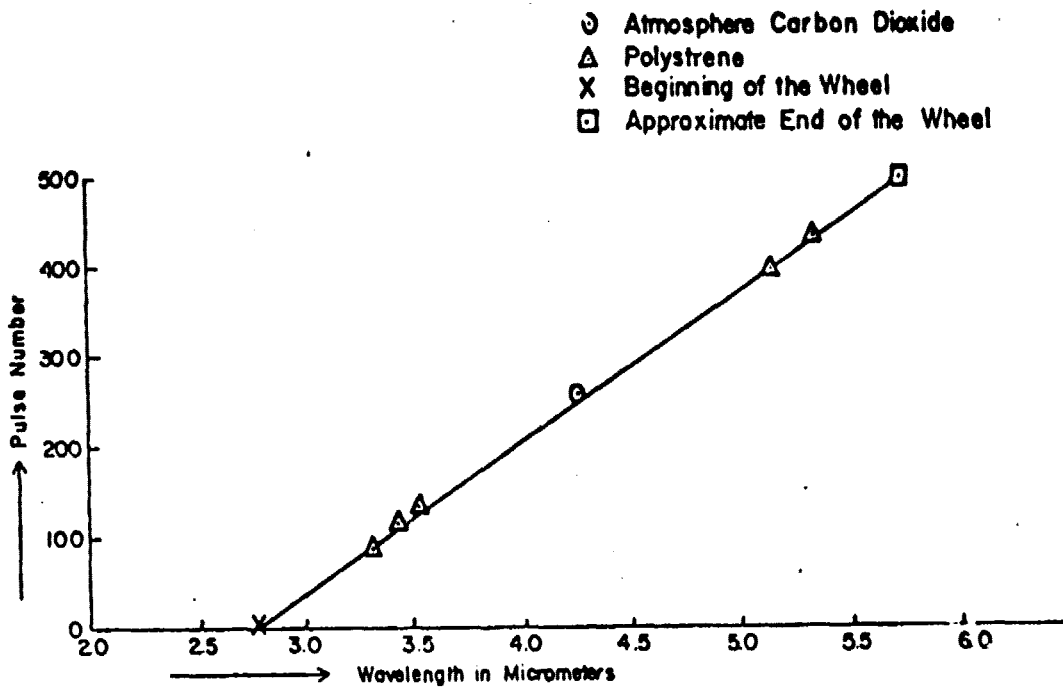

Figure 3 - Wavelength calibration for Indium Antimonide Channel

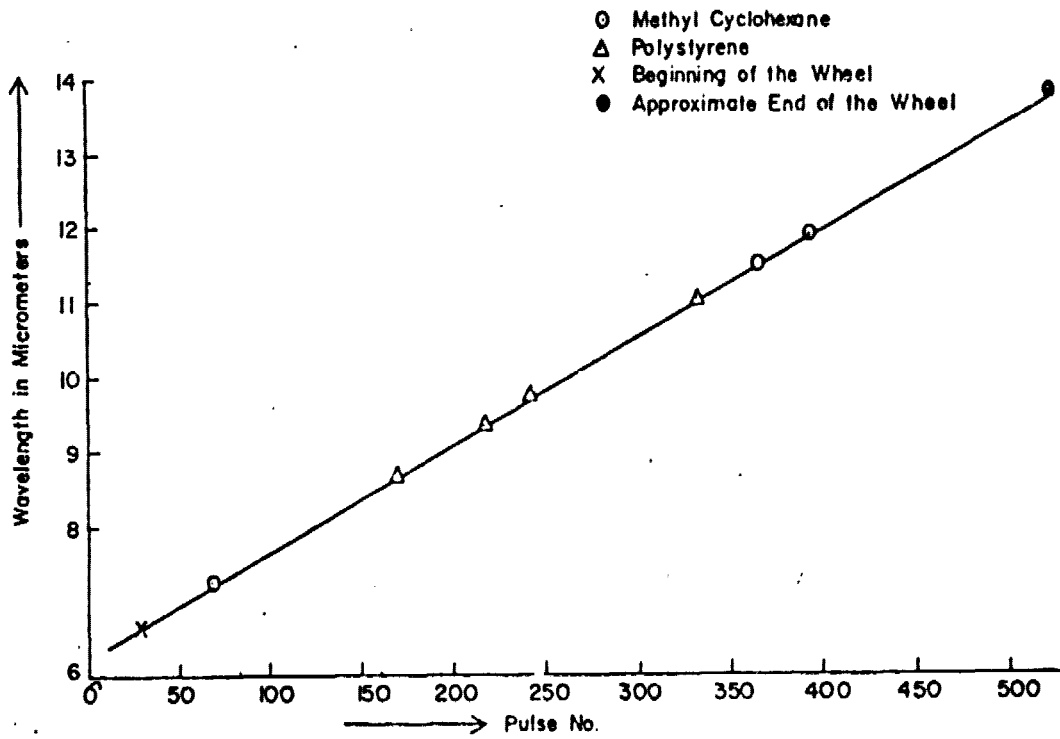

Figure 4 - Wavelength calibration for Mercury Cadmium Telluride Channel.

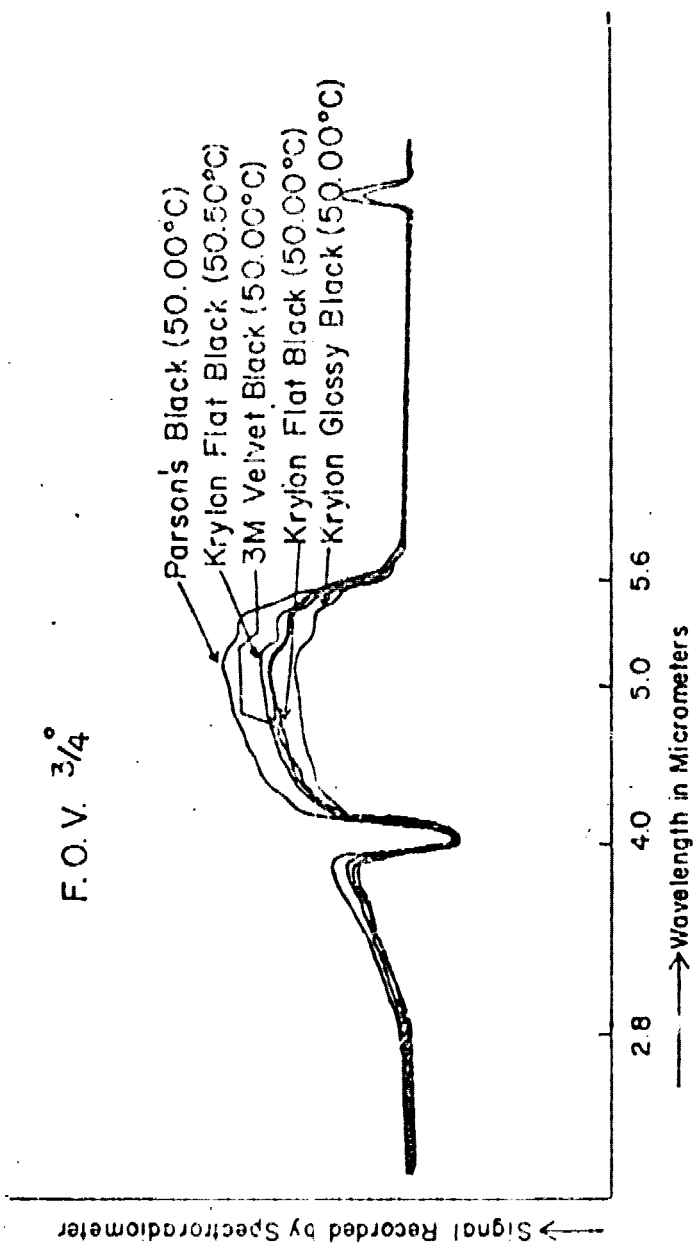

Figure 5 - Comparison of the Emittance of Paints in Indium Antimonide Channel.

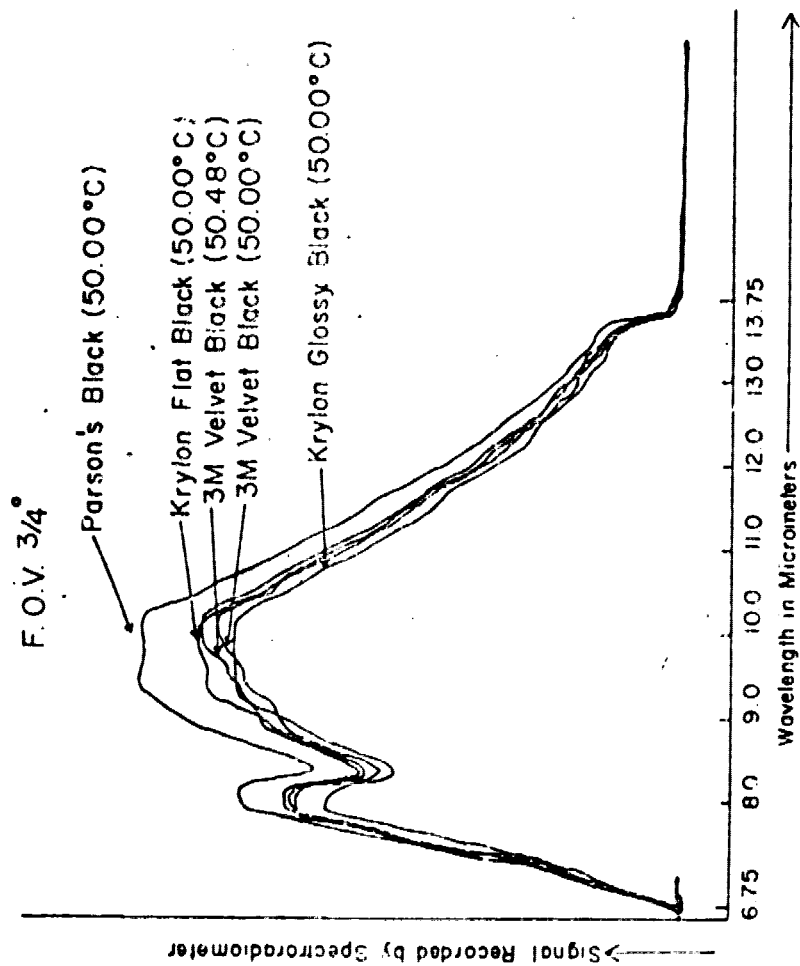

Figure 6 - Comparison of Emittance of Paints in Mercury Cadmium Telluride Channel.

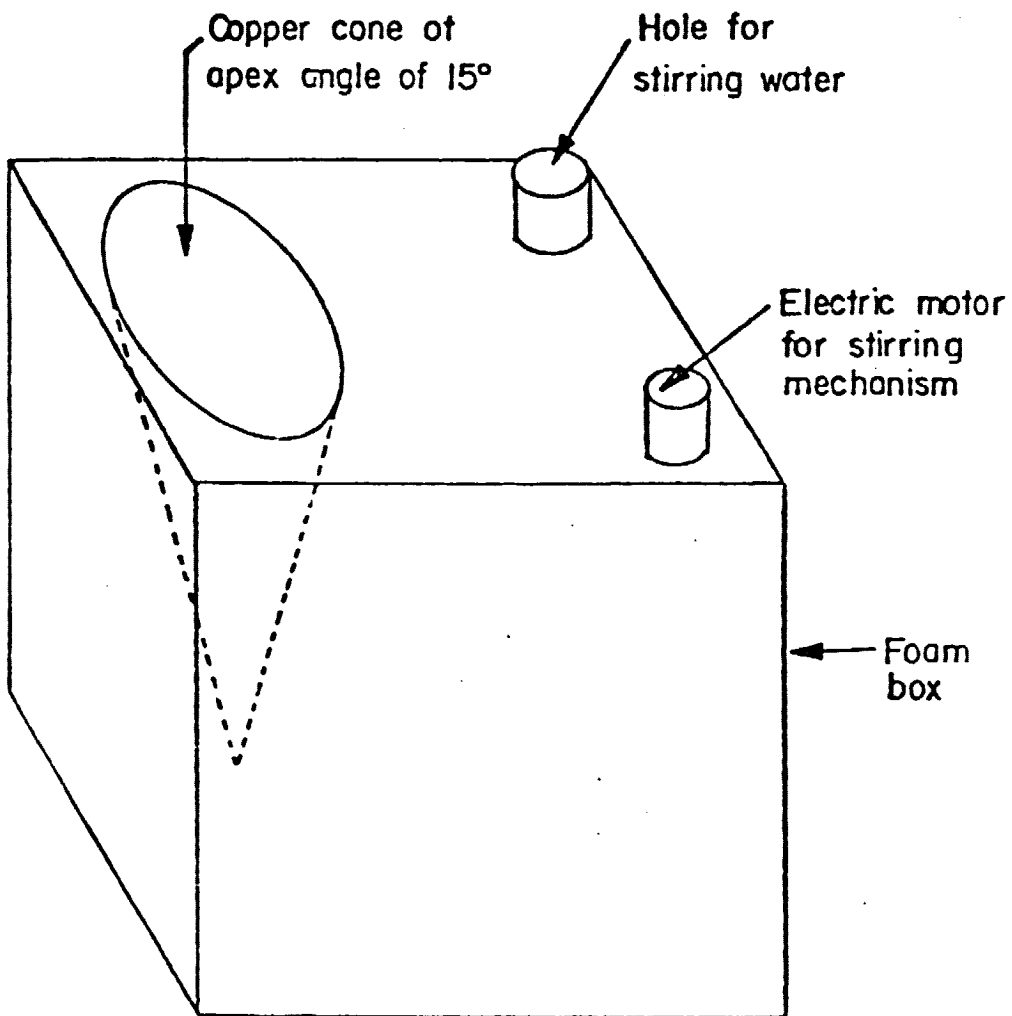
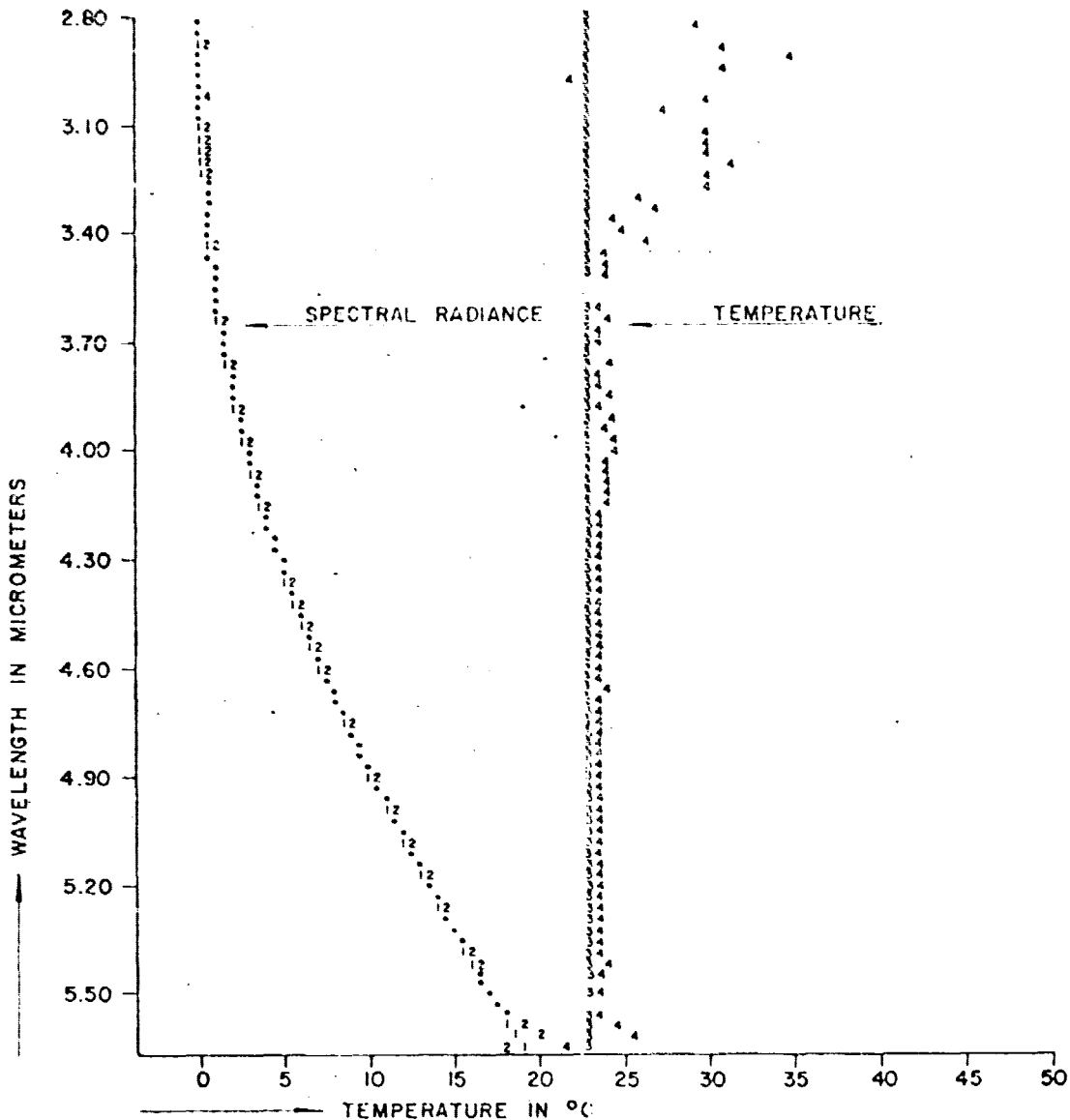

Figure 7 - Blackbody



- 1- THEORETICAL VALUE OF SPECTRAL RADIANCE
- 2- COMPUTED VALUE OF SPECTRAL RADIANCE
- 3- ACTUAL VALUE °C
- 4- COMPUTED VALUE °C
- AGREEMENT BETWEEN ACTUAL (OR THEORETICAL) AND COMPUTED VALUE

Figure 8 - Theoretical and Computed Values of the Spectral Radiance and Temperature in Indium Antimonide Channel. The characters 1 and 2 indicate theoretical and computed values of the spectral radiance respectively. The characters 3 and 4 indicate the actual and computed values of the temperature respectively.

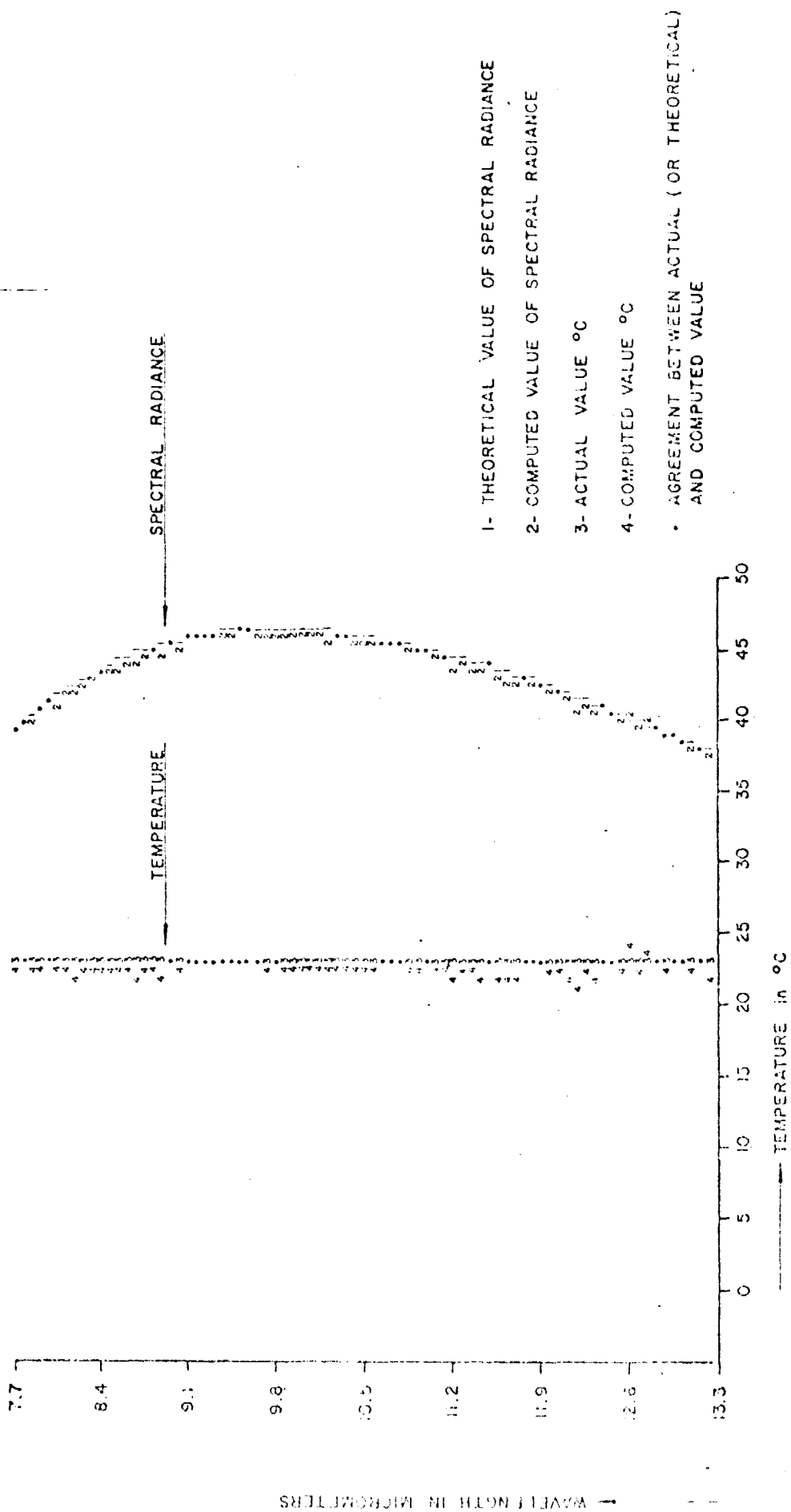

Figure 9 - Theoretical and Computed Values of the Spectral Radiance and Temperature in Mercury Cadmium Telluride Channel. The Characters 1 and 2 indicate theoretical and computed values of the spectral radiance respectively. The characters 3 and 4 indicate the actual and computed values of the temperature respectively.