

General Disclaimer

One or more of the Following Statements may affect this Document

- This document has been reproduced from the best copy furnished by the organizational source. It is being released in the interest of making available as much information as possible.
- This document may contain data, which exceeds the sheet parameters. It was furnished in this condition by the organizational source and is the best copy available.
- This document may contain tone-on-tone or color graphs, charts and/or pictures, which have been reproduced in black and white.
- This document is paginated as submitted by the original source.
- Portions of this document are not fully legible due to the historical nature of some of the material. However, it is the best reproduction available from the original submission.

MULTI-KW DC DISTRIBUTION SYSTEM TECHNOLOGY RESEARCH STUDY

(NASA-CR-150789) MULTI-KW dc DISTRIBUTION	N78-31353
SYSTEM TECHNOLOGY RESEARCH STUDY Final	
Report (TFW Defense and Space Systems Group)	
119 p HC A06/MF A01	CSSL 09C
	Unclas
	G3/33 29125

FINAL REPORT

JULY 1978

Prepared by:
S. G. DAWSON

Prepared for:

GEORGE C. MARSHALL SPACE FLIGHT CENTER
NATIONAL AERONAUTICS AND SPACE ADMINISTRATION
Marshall Space Flight Center, Alabama



TRW

DEFENSE AND SPACE SYSTEMS GROUP

ONE SPACE PARK • REDONDO BEACH • CALIFORNIA 90278

MULTI-KW DC DISTRIBUTION SYSTEM
TECHNOLOGY RESEARCH STUDY
FINAL REPORT

JULY 1978

Prepared Under the Direction of
Jerald L. Felch, Program Monitor
Contract NAS8-31719

George C. Marshall Space Flight Center
National Aeronautics and Space Administration
Marshall Space Flight Center, Alabama

Prepared by
S. G. Dawson
Approved by
D. W. Zerbel

TABLE OF CONTENTS

	<u>Page</u>
1.0 INTRODUCTION	1-1
2.0 SOURCES	2-1
2.1 Candidate Sources	2-1
2.1.1 Fuel Cell Power Plant	2-1
2.1.2 Batteries	2-9
2.1.3 Alternator/Generators	2-15
2.1.4 Solar Array	2-26
2.2 Sources Summary	2-33
3.0 APPLICATION ANALYSIS	3-1
3.1 Manned Spacecraft Power Systems	3-1
3.2 Power System Components	3-3
3.3 Shuttle Payload Support	3-10
4.0 SAFETY ANALYSIS	4-1
4.1 Hazards to Personnel	4-1
4.2 Relative Safety	4-2
4.3 Corona and Consequences of Electrical Breakdown	4-3
4.4 Relation of Protective Devices to Safety	4-5
4.5 Experience with DC Systems of 100 Volts or Over	4-6
4.6 Institutional Aspects of Safety Related to Use of 120 or 300 Volts DC	4-6
4.6.1 NEC, NFPA, ANSI-C1	4-6
4.6.2 OSHA	4-7
4.6.3 AF, SAMSO, Safety Specifications	4-7
4.6.4 NASA ICD 19001 Electrical Safety	4-9
5.0 TEST FACILITY MODIFICATIONS	5-1
6.0 TECHNOLOGY ASSESSMENT	6-1
6.1 Sources	6-1

TABLE OF CONTENTS (CONT'D)

	<u>Page</u>
6.1.1 Solar Arrays	6-2
6.1.2 Fuel Cells	6-3
6.1.3 Batteries	6-3
6.1.4 Rectified Alternators	6-3
6.2 Switching Components	6-3
6.3 Cables	6-8
6.4 Connectors	6-8
6.5 Controls and Supervision	6-9
7.0 STUDY CONCLUSION	7-1
APPENDIX A-1	A1-1
APPENDIX A-2	A2-1
APPENDIX A-3 REFERENCE	A3-1
APPENDIX A-4 BIBLIOGRAPHY	A4-1

1.0 INTRODUCTION

Anticipated power requirements for aerospace vehicles are increasing to levels which stress the capabilities of current electrical distribution and control design approaches. Attendant cable and component weight increases will increase operating costs of multiple mission vehicles. High currents, coupled with long power distribution cables and electromechanical switchgear generate significantly higher levels of electromagnetic interference which are difficult to control or predict. A recent NASA sponsored Power Processing, Distribution and Control Study (NAS8-26270) disclosed that the use of techniques which utilize distribution voltages in excess of 100 Vdc and multiplexed digital supervision and control methods in conjunction with solid state switchgear are capable of overcoming these difficulties. A NASA/MSFC Power Processing, Distribution and Control Technology Development Program was initiated to supply these needs and demonstrate the performance and availability of modern state-of-the-art electrical distribution techniques.

The first phase of this program (Contract NAS8-28726) provided the detailed definition of the program and associated test objectives, recommendations for selection and sizing of the test articles and recommended test approaches. In addition a study of thermal and electrical characteristics of catastrophic line faults was initiated. The second phase of the study project (Contract NAS8-30778) provided detailed electrical design of the test article elements, laboratory layout and identification of available industrial quality equipment and parts required to support the simulation of a large aerospace electrical distribution system. Associated studies included continued analysis of distribution harness noise and parameterizing of load interface design and power system performance as a function of distribution voltage.

The Multi-KW DC Distribution System Technology Research Study (Contract NAS8-31719) is the third phase of the NASA/MSFC study program. The purpose of this contract was to complete the design of the integrated technology test facility, provide test planning, support test operations and evaluate test results. The subject of this study is a continuation of this contract. The purpose of this continuation as outlined in the Scope of Work is to study and analyze high voltage system safety, to determine optimum voltage levels versus power, to identify power distribution system components which require development for higher voltage systems and finally to determine what modifications must be made to the Power Distribution System Simulator (PDSS) to demonstrate 300 Vdc distribution capability.

2.0 SOURCES

2.1 Candidate Sources

Four types of power sources were evaluated for the effect of output voltage on their performance/design parameters: fuel cell, battery, solar array, and alternator/generator. These power source types were not compared to each other for source selection. Rather, the effect of output voltage level (30, 120, 300 volts) on the design parameters within each source type was evaluated. Consequently, the prime mover (e.g. turbine source) for the alternator/generator was not evaluated as its design is considered to be independent of generator output voltage. Other sources, e.g., radio-isotope thermoelectric generators (RTG), are not considered germane to the power levels of 10, 50, and 100 kilowatts of this study.

2.1.1 Fuel Cell Power Plant

A fuel cell catalytically and stoichiometrically combines gaseous hydrogen and oxygen (the reactants) to produce electrical power in the form of direct current. Heat and water are bi-products. The Space Shuttle fuel cell power plant (Figure 2-1 and 2-2) consists of 64 fuel cell elements of 0.5 square foot active area each and are arranged in a single physical stack assembly together with the ancillary equipment for reactant control, water removal, and heat rejection. The fuel cell elements are electrically series connected into substacks of 32 cells to produce the nominal 30-volt output. The two substacks are electrically parallel connected. All cells are parallel connected to manifolds for hydrogen and oxygen supply.

Configuration

The Space Shuttle fuel cell stack was utilized as the baseline building block to hypothesize the 10, 50, and 100 kilowatt configurations (Table 2-1). The Shuttle power plant is considered a 30-volt, 7-kilowatt unit for sustained operation. It weighs 204 pounds, with 80 pounds allocated to the two fuel cell stacks.

ORIGINAL PAGE IS
OF POOR QUALITY

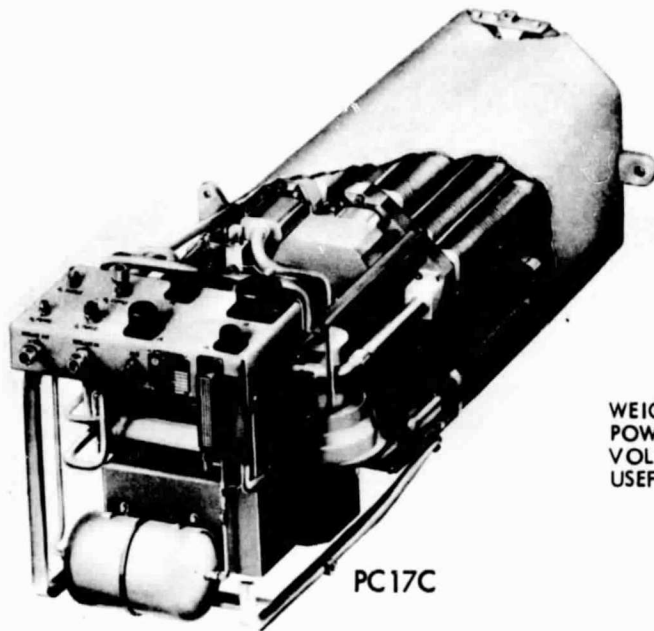

WEIGHT
POWER OUTPUT
VOLTAGE (2-12-KW)
USEFUL LIFE

204 LB
12 KW
27.6 - 32.5 VOLTS
5000 HOURS

PC17C

Figure 2-1. Orbiter Fuel Cell Powerplant

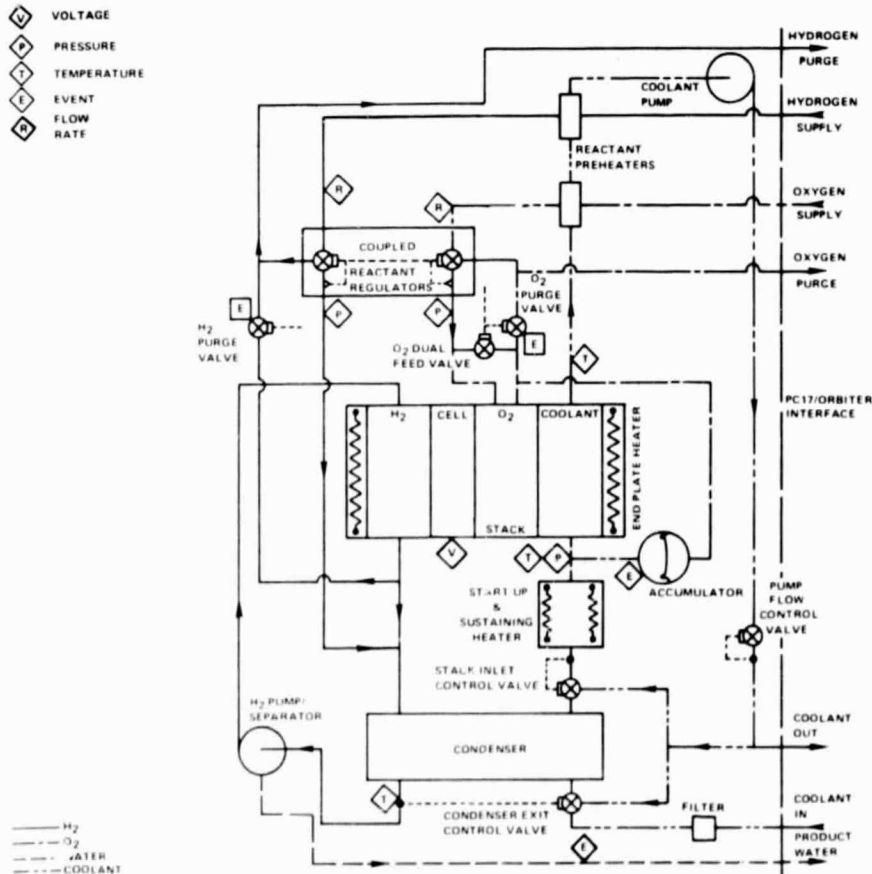

Figure 2-2. Fuel Cell Schematic for Reactant Control, Thermal Control, and Water Removal

Table 2-1

FUEL CELL - BASED ON ORBITER CELLS

	<u>10 KW</u>	<u>50 KW</u>	<u>100 KW</u>
30 Volt	3 stacks - 32 cells	15 stacks - 32 cells	28 stacks - 32 cells
Configuration			
Weight, Unjt/Stack, lbs	245/120	738/600	1260/1120
Volume, ft ³	5.8	16	27
Cost, \$	250,000	1,170,000	2,330,000
Availability	off shelf	need new cell	need new cell
Reliability, Cells	96	480	896
Fault Current, Amperes	8,000	37,500	75,000
Regulation, Open Circuit Voltage	40	40	40
120 Volt	1 stack - 128 cells	4 stacks - 128 cells	7 stacks - 128 cells
Configuration			
Weight, Unjt/Stack, lbs	285/160	778/640	1310/1120
Volume, ft ³	6.7	17	29.1
Cost, \$	312,000	1,330,000	2,330,000
Availability	off shelf	off shelf	could use larger cell
Reliability, Cells	128	512	896
Fault Current, Amperes	2000	9,000	18,750
Regulation, Open Circuit Voltage	160	160	160
300 Volt	1 stack - 107 cells	2 stacks - 320 cells	3 stacks - 320 cells
Configuration			
Weight, Unjt/Stack, lbs	259/134	938/800	1340/1200
Volume, ft ³	6.1	20	37
Cost, \$	544,000	1,670,000	2,500,000
Availability	modified cell*	off shelf	off shelf
Reliability, Cells	320	640	960
Fault Current, Amperes	800	3750	5600
Regulation, Open Circuit Voltage	400	400	400

*Based on Shuttle cell divided electrically into 3 cells of .1 square foot

2-3

For this study, a 10-kilowatt unit is hypothesized consisting of three 32-cell stacks, weighing 245/120 pounds (unit/stack weight), and utilizing the same Shuttle ancillary equipment. With stacks connected in parallel, it is a 30-volt unit. If an additional stack is added and the four stacks are connected in series, a 120-volt 14-kilowatt unit results. These units are considered "off-the-shelf" as they use the same cell and ancillary equipment as the Orbiter.

A 300-volt fuel cell requires 320 series connected cells. The present Shuttle cell area is too large for the building block for a 10-kilowatt unit. (It would produce a 35 -kilowatt power plant.) Consequently, a unit consisting of one stack of 107 cells, wherein each cell has been subdivided into the three electrically isolated areas, is hypothesized for the 300-volt, 10-kilowatt power plant. For weight and volume, this is considered equivalent to 3, 32-cell stacks of the Shuttle design. This unit requires a cell modification, and hence some development effort.

A similar approach is used to derive the 50- and 100-kilowatt power plants. However, the 30-volt, 50-kilowatt and 100-kilowatt units require 15 and 28 stacks in parallel. Obviously, a new, larger-area cell design is warranted for actual units.

No attempt was made to re-size the peripheral equipment in scaling up the Shuttle power plant to 50 and 100 kilowatts. It was assumed the existing reactant regulators and purge valves have sufficient flow capacity for the larger ratings. Actual power plant design must verify this and undoubtedly provide larger capacity thermal control devices. However, this equipment has little impact on the total weight or volume of the power plant and is not affected by output voltage selection.

Size

The weight of a fuel cell power plant is dependent upon the power rating and operating conditions (cell current density and thermal cooling method)

rather than voltage. The rating and the current density to which the cells will be operated determine the total fuel cell area (and hence total cells) to assemble into a power plant. However, the individual cells of a power plant may be electrically interconnected into appropriate series/parallel combinations to provide essentially whatever nominal output voltage is desired.

For example, a 14-kilowatt, 30-volt power plant requires 128 cells arranged as one module of four electrical stacks of 32 cells each. The 14-kilowatt, 120-volt power plant also requires 128 cells but arranged in one stack of 128 cells. Hence, the total cell area is the same and the current density per unit cell area is the same for either 14-kilowatt power plant. Consequently, the weight of cells is the same (120 pounds). The peripheral equipment is also the same as the gas (reactant) flow requirements are identical and the cooling provisions (thermal control) are identical -- the same internal losses for identical current density (operating point). Hence, the weight of the units are identical and independent of output voltage selection.

Power plant volume is also correspondingly dependent upon rating and operating conditions (which specify total cell area required) rather than voltage. Volume is determined by the total quantity of cells (total cell area) and the thermal control media. Neither of these are related to voltage.

Availability

The Space Shuttle fuel cell module was chosen as the baseline building block. Consequently, the hypothesized power plant at 30 volts and 120 volts ratings are also off-the-shelf provided the existing ancillary equipment is sufficient for the larger ratings (50 and 100 kilowatts). However, the large quantity of parallel connected stacks for the 50 and 100 kilowatt power plant ratings suggest a new larger cell be designed for actual power plant hardware.

The 300-volt, 10-kilowatt power plant requires a cell modification to effectively produce three cells of 0.1 square foot area from the present Shuttle cell. Hence, this power plant is not available without cell re-development. The obvious approach is to use 320 of the existing cells and produce a 35 kilowatt unit as the minimum size at 300 volts.

Reliability

Fuel cell failures do not follow the pattern of space rated batteries. The failure mechanism that is most significant, as reported by Pratt & Whitney, is progressive degradation due to carbonate formation and contamination of the electrolyte matrix. This degradation is readily reduced to tolerable levels by carbon dioxide/monoxide scrubbers in the reactant supply. Inert gas buildup and consequent performance reduction is remedied by purging -- controlled venting of the cell reactant cavities. Therefore, life expectancy of a power plant can be projected from 2,000 hours to over 40,000 hours depending upon the grade (purity) of reactants and the decontamination methods implemented. Both of these approaches to long life are independent of the output voltage rating of the power plant.

Cost

The present projection of fuel cell power plant production cost is \$25,000 per kilowatt. This cost is essentially for the fuel cell stack; the ancillary equipment is modest. No significant cost improvement is seen in the larger power plants without a new cell design. Hence, power plant costs are scaled directly by power rating (total cell quantity), and are not related to power plant output voltage.

Fault Current

The fuel cell power plant fault current is a direct relationship to the area of fuel cells in parallel. The Shuttle power plant has a 6,000 ampere fault capability on two parallel stacks of cells of 0.5 square foot area (Figure 2-3).

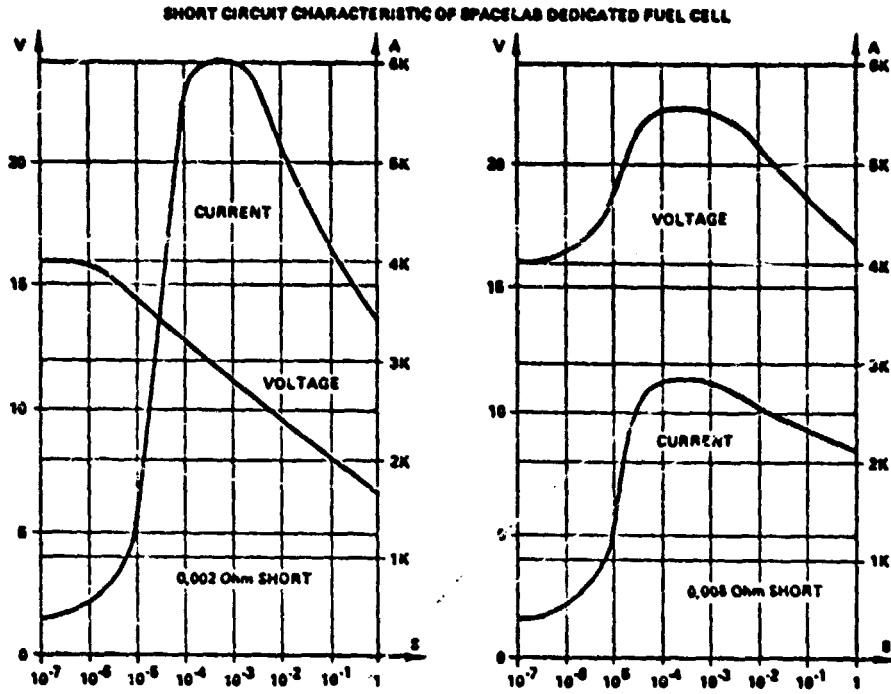

Short Circuit Characteristic of Spacelab Dedicated Fuel Cell

FIGURE 2-3

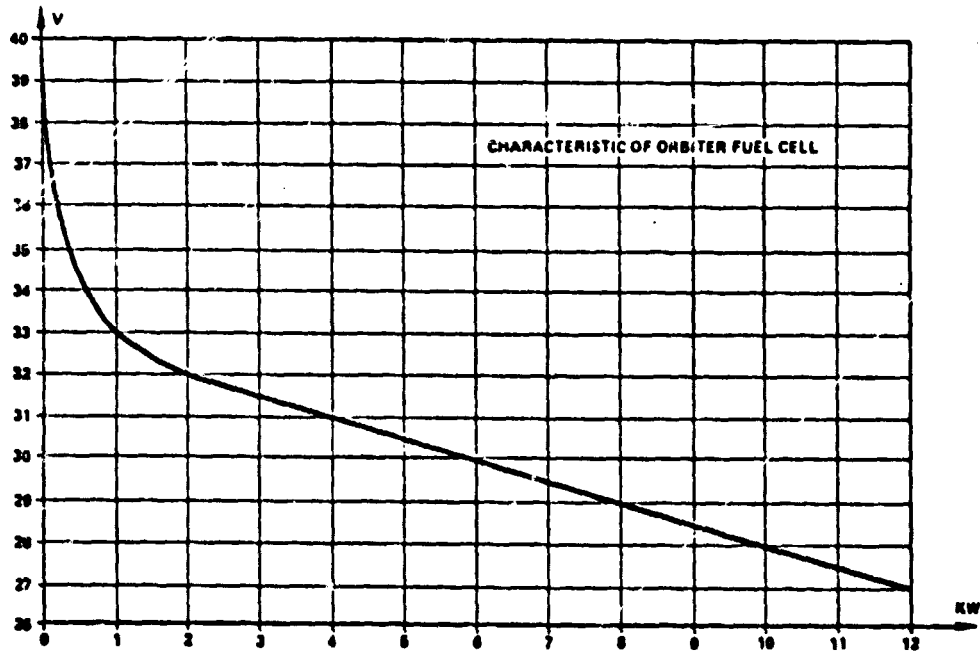

Characteristic of Orbiter Fuel Cell

FIGURE 2-4

Hence, the 30-volt, 10-kilowatt unit is expected to have 8,000 ampere fault capability. The fault current capability increases directly with the larger power plant ratings as the paralleled fuel cell area increases directly with rating.

Fault current capability reduces directly proportional to power plant output voltage for a given power rating. This is because the paralleled cell area, and hence the ability to produce current, is inversely proportional to output voltage for a given power rating. Hence, the fault currents of the 120-volt and 300-volt power plants are 1/4 and 1/10 of the 30-volt power plant capability.

Sustained fault current production can be limited by interrupting the reactant flow. However, residual reactants in the cell cavities will continue to produce current. The total current producing capability of a 10-kilowatt, 30-volt power plant is estimated at 13,000 ampere-seconds after interruption of reactants. For a one milliohm short circuit, the time to zero current would be on the order of three seconds.

Regulation

The alkaline matrix fuel cell has an open circuit potential of essentially 1.2 volts, but produces only 0.9 volts at full load (Figure 2-4). Hence, power plant open circuit voltages are very high: 40, 160 and 400 volts, respectively. Normal operation avoids these values by maintaining a minimum load (25-30 percent of rating) on the power plant. (This may be unrealistic with the larger power plants.) However, equipment supplied by a fuel cell power plant should be designed to tolerate (suffer no damage) from these open-circuit voltages.

Voltage

Gemini and Apollo missions utilized 30-volt fuel cell power plants. The Space Shuttle power plant is also a 30-volt unit. However, 120-volt power plants, employing the basic Shuttle cell design, have been successfully built

and tested for the deep submersible program of the Navy. Further, commercial fuel cell power plants have been built and operated at 1400 and 1600 volts by United Technology (Pratt & Whitney) using their acid system. Consequently, voltages significantly above 30 volts have been demonstrated and are feasible. No problems have surfaced with extended series electrical connection of fuel cells into high voltage power plants.

Peripheral equipment is presently designed for 30-volt operation on the Shuttle power plant. This equipment is directly applicable to power plants of higher voltages by providing a 30-volt tap for operation of this equipment. Such a tap is feasible; no cell imbalance will occur. Only slightly added gas (reactants) will be consumed in the cells providing the control current. Hence, even the high voltage power plants are "off-the-shelf" by utilizing these 30-volt controls.

2.1.2 Batteries

Batteries are an energy dependent device rather than power dependent. Therefore, the power plant ratings of 10, 50, and 100 kilowatts were converted into 6, 30, and 60 kilowatt-hours of usable energy at these respective rates to support a 0.6-hour eclipse of a low-earth-orbit satellite (see Table 2-2). Depth of discharge allowances appropriately increase the battery nameplate ratings. Further, a single battery was sized for each rating, as with the power conversion sources, rather than paralleling several smaller batteries to produce the rated capacity. This produced cell capacity requirements well beyond the state-of-the-art. Therefore, additional battery ratings were considered for suitable modular building blocks.

Only one battery type, nickel-cadmium, was considered in depth for the high-cycle life (35,000) and long duration (5 years) required by an orbital satellite. The nickel-hydrogen cell is a viable alternative for life and has potential to supplant the nickel-cadmium cell if scale up and better packaging can be achieved.

Table 2-2

BATTERY - NICKEL CADMIUM - LOW EARTH ORBIT .6 HOURS/ORBIT 25 PERCENT DEPTH OF DISCHARGE

	<u>10 kW</u> (6 kW)	<u>50 kW</u> (30 kW)	<u>100 kW</u> (60 kW)
30 volts			
Configuration-Cells	24, 833 AHr	24, 4167 AHr	24, 8333 AHr
Weight lbs	3100	15,500	31,000
Volume ft ³	233	116.5	233
Cost \$	287,000	1,300,000	2,500,000
Reliability	.93	.93	.93
Fault Current, amps	80,000	400,000	800,000
Regulation, volts	36-24	36-24	36-24
120 volts			
Configuration-Cells	96, 203 AHr	96, 1040 AHr	96, 2080 AHr
Weight lbs	3100	15,500	31,000
Volume ft ³	23.3	116.5	233
Cost \$	324,000	1,250,000	2,600,000
Reliability	.75	.75	.75
Fault Current, amps	20,000	100,000	200,000
Regulation, volts	144-100	144-100	144-100
300 volts			
Configuration-Cells	240, 83 AHr	240, 417 AHr	240, 833 AHr
Weight lbs	3100	15,500	31,000
Volume ft ³	23.3	116.5	233
Cost \$	400,000	1,250,000	2,500,000
Reliability	.49	.49	.49
Fault Current, amps	8000	40,000	80,000
Regulation, volts	360-264	360-264	360-264

2-10

29817-6001-TU-00

Nickel-Cadmium Battery

A five-year life for a low earth orbit satellite requires approximately 35,000 charge/discharge cycles. Present technology indicates an allowable depth of discharge of 25 percent. Hence, the battery (and cell) nameplate capacities of Table 2-2. Except for the 83 and possibly the 208 ampere-hour cells, these requirements are beyond the nickel-cadmium space technology for the present, although 500 and 1000 ampere-hour cells are under consideration. Note, however, that 4167 and 8333 ampere-hour cells are required to meet the 50 and 100 kilowatt power ratings for a single unit at 30 volts. These large cell capacities are not totally unrealistic, as capacities of this range have been built for storage-battery powered submarines. However, lead-acid or nickel-iron technology is usually employed, but one French design employed nickel-cadmium cells.

Size

The larger cells are hypothesized based upon the 100-ampere hour nickel-cadmium cell development. A direct scale-up based on capacity (ampere-hours) is used for weight and volume. Such scale-up is considered sufficient for this study. Cell packaging efficiency improvements, beyond that attained with the 100-ampere-hour design, are expected to suffer from the trade off of heat removal, current collection, and physical support of the plates in larger cells.

Availability

The 50-ampere-hour cell is off-the-shelf and has been assembled into 30-volt batteries. The 100-ampere-hour cell has been built and tested and is, therefore, considered available. Scale-up to the 200-ampere hour requirement of the 10-kilowatt, 120-volt unit is projected as an engineering task -- not a development effort. However, the other cells are beyond the present state of nickel-cadmium development for space application.

Using the 100-ampere-hour cell, three batteries were configured at 30, 120, and 300 volts (Table 2-3), corresponding to 1.2, 5, and 12 kilowatt ratings. For the present, these are the largest nickel-cadmium batteries produceable. Multiple units could be used for the 10, 50, and 100 kilowatt ratings.

Reliability

The battery reliability values (Table 2-2 & 2-3) are derived based upon a single cell reliability of 0.997. Only open circuit cell failures are considered catastrophic. Shorted cells are tolerable and yield only capacity and regulation degradation. This is especially true for the 120-volt and 300-volt batteries wherein shorting of one cell becomes virtually insignificant.

Battery reliability suffers as a direct power of the number of cells connected in series: $R_B = (R_C)^n$, n =number of cells in battery. This penalizes the higher voltage units accordingly. However, high-voltage high-capacity batteries were used as the energy storage medium for electric submarines. Reliability was not a problem as individual cell maintenance was possible. Similarly, high-voltage batteries for space application require an efficient method to bypass open (or poor performance) cells. Such a development is required to produce adequate reliability for an individual battery. Otherwise, great numbers of smaller capacity batteries, operated in parallel, are required to attain a reliability prediction comparable to present 30-volt battery systems.

Consideration should be given to the application of these high power levels to assess actual battery reliability needed. For example, if the power is essentially to perform space processing (zero-gravity manufacturing) a low value of battery reliability may be acceptable and economically viable. Presumably, material delivery and product output transport could also provide any needed battery replacements. In this event, 100-ampere-hour, 240-cell batteries potentially represent an acceptable approach, even though the individual battery reliability projection is low.

TABLE 2-3
NICKEL CADMIUM BATTERY - LOW EARTH ORBIT

Configuration	24, 100-Ahr cells	96, 100-Ahr cells	240, 100-Ahr cells
Nameplate ratings	2880 watt-hours 1.2 kW	11,540 watt-hours 5 kW	28,800 watt-hours 12 kW
Usable energy	720 watt-hours	2900 watt-hours	7200 watt-hours
Weight	240 lb	960 lb	2400 lb
Volume	2.8 cu ft	11.2 cu ft	28.0 cu ft
Cost	\$86,000	\$204,000	\$430,000
Availability	Developed	Packaging required	Packaging required
Reliability	.93	.75	.49
Fault Current	10,000 amperes	10,000 amperes	10,000 amperes
Regulation	36-26 volts	144-100 volts	360-264 volts

Cost

The present projection of cell production cost is \$1500 for a 100-ampere-hour unit and includes acceptance testing. Costs for larger cells were directly scaled by ampere-hour capacity at an incremental rate of \$1200/100 ampere-hours as a first order approximation of battery production costs. In addition a \$50,000 to \$70,000 battery assembly cost is projected for the smaller batteries. This assembly cost was arbitrarily doubled for the larger-cell batteries to account for increased handling effort of the much heavier cells. No attempt was made to assess development costs for the larger cells/batteries.

Fault Current

The fault currents listed in Table 2-3 are essentially 100C rates (100 x cell capacity in ampere-hour). This is a first order approximation of the anticipated battery terminal capability. In the case of the 24-cell batteries, fault resistances must be exceedingly low to realize these fault currents. Consequently, fault resistances are expected to limit actual fault current flow to lower values. This is not as true of the high voltage batteries. Increased driving potential voltage is available to drive fault currents into proportionately higher fault resistances.

Regulation

The open circuit potential of 1.2 volts per cell produces batteries of 28.8, 114, and 288 volts. These voltages are slightly below the system potentials (30, 120, and 300 volts). Consequently, the batteries would be trickle charging at the nominal voltages. Normal lower regulation is projected at 1.1 volt/cell and yields 26.4, 105.6, and 264 volts. Overcharge voltages of 1.5 volt/cell produce 36, 144, and 360 volts at the respective battery terminals. Hence, the system regulation voltages tabulated in Tables 2-2 and 2-3.

2.1.3 Alternators/Generators (See Block Diagram Figure 2-5)

Alternators that are candidates for power in manned and unmanned larger space vehicles center around three basic types:

- a. Wound rotor, gas or liquid cooled as used in aircraft
- b. Solid rotor with permanent magnet field (no field control)
- c. Solid rotor with no winding on the rotor but with field control.

Speed and operating frequency used for alternators are usually higher for small machines. All are limited by the peripheral speed of the magnet containment structure on the shaft. There are large variations in the relative characteristics for efficiency and weight. Designs that stress efficiency suffer from increased weight. Most of the literature is on units used through speed range changes. This won't be required for space application.

Configuration

Wound Rotor Brushless

Wound rotor brushless machines have three separate windings with one of them being a conventional three phase stator output winding. The field poles are wound on the rotor with another ac winding that is used to power the diodes that power the field poles. The diodes, the field poles, and the ac winding that is the excitation source to the field all rotate with the shaft. Control power for both excitation and protective equipment is derived from the shaft mounted permanent magnets that excite a stator winding that is ac and usually of higher frequency than the basic ac winding for the main power output. This control power is rectified in the controller of the system used for the machine to provide dc excitation and generator contactor control power. This excitation is used to power a stator winding that excites the ac rotor winding previously discussed. In aircraft, very high density power ratings have been accomplished in small volumes by use of liquid cooling that traverses rotating seals for circulation in and out of one end of the rotor shaft. This cooling removes bearing, rotor winding and iron losses. Space rated units would utilize liquid cooling also.

ORIGINAL PAGE IS
OF POOR QUALITY

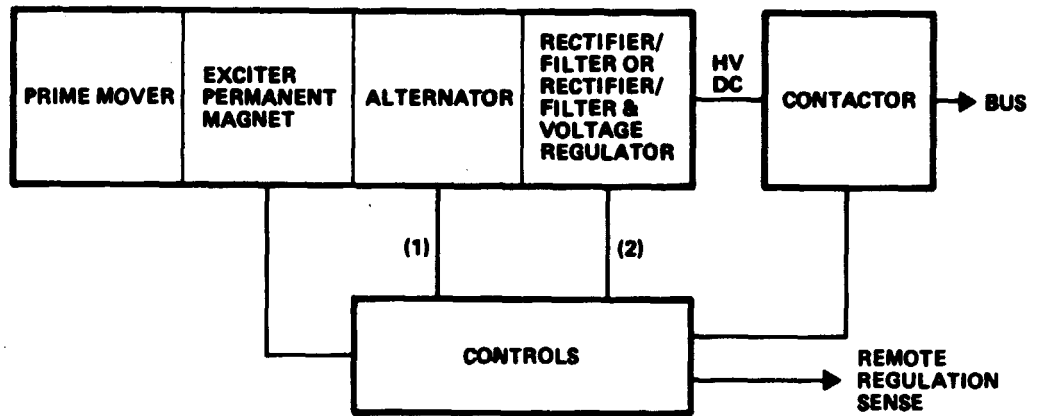

- (1) FIELD FOR WOUND ROTOR OR HOMOPOLAR
(2) VOLTAGE REGULATION GATE SIGNALS -
PERMANENT MAGNET

Alternator/Generator Block Diagram

Figure 2-5

For dc machines, the most common arrangement is to locate the diodes that rectify the main stator power in the stator enclosure. There are two types of installation used for the solid-state rectification; i.e., they are heat sink cooled with liquid not in contact with the switches or they are immersed in the coolant. Output voltage regulation is accomplished by controlling the magnitude of the dc applied excitation so that ordinary diodes may be used to rectify the ac to dc. Transistors and SCR's may be used to perform the output contactor switching function between the machine and the bus it serves and replace the function of the diodes.

Permanent Magnet Machines

Permanent magnet alternators use electronics to regulate voltage. The field poles are permanent magnets bonded or banded to the rotor shaft. In many applications for use as HVDC generators, rotor position sensors would be required. Permanent magnet machines are usually constructed with a smooth rotor and are smaller than the wound type with improved reliability, and weight. Their efficiency is excellent in the small kW sizes that have been built. Regulation transistors or SCR's can be enclosed in the stator housing and receive gate control from electronics packaged separately. Pulse width modulation (PWM), phase displaced rectifiers (PDR) and dc choppers have been used to regulate voltage.

Stator windings are conventional two phase or three phase windings and are provided with cooling. Multiple windings and relatively high frequencies and speeds are characteristic. This provides a low continuous current rating on the solid-state rectifiers in terms of the dc output current of each phase winding. The wave form of a permanent magnet generator is not a pure sine wave. It is heavily notched in the center portion which generates heavy harmonic content adding complexity to the gate controlled rectifying circuits and increases filter requirements on the ac side of the rectification or on the dc output. Use of higher voltage permits lower current in the rectified components and reduces the conducted and radiated noise for a given kVA rating. The controlled rectifier can be used to turn off the output reducing the switching service required of the output contactor.

Homopolar Alternators

Five types of homopolar alternators could be used on a HVDC space rated system.

1. Inductor
2. Lundell
3. Inductor-Lundell
4. Nadyne
5. Rice

The inductor machine of Figure 2-6 comprises a double ended homopolar design having the field excitation windings mounted on the stator in a central position between the two stators and radially outside of the stator conductors. Two stator sections are required to generate maximum power from a given air gap flux. One stator section uses only north pole flux and the other only south pole flux. At each stator pole the flux alternates from essentially zero to full plus (north) or full minus (south) respectively.

In the Lundell machine of Figure 2-6, the magnetic flux flows axially in two directions across a concentric gap at the end of the rotor. The flux circuit is from a rotor pole, across a radial gap into the stator field coil iron and then back to the next rotor pole of opposite polarity. High flux leakage and a high weight per kVA result.

The Inductor-Lundell machine combines the features of the previous two machines, Figure 2-6. At each end of the rotor, voltage is induced in the stator conductor by a magnetic flux alternating from a given value to zero. The plus flux (north) is on one end and the minus flux (south) on the other end. This uses only half of the capacity of the magnetic steel. The generator section is at a positive magnetic potential with respect to the surrounding iron parts and an axial flux passes across the stator iron which requires the stator to be magnetically insulated from the magnetic frame.

In the Nadyne machine the magnetomotive force of a north or a south pole is only that required for a single salient pole air gap. Other inductor types required the magnet to be the magneto force of a north and a south that is required of two generator air gaps in series (see Figure 2-7).

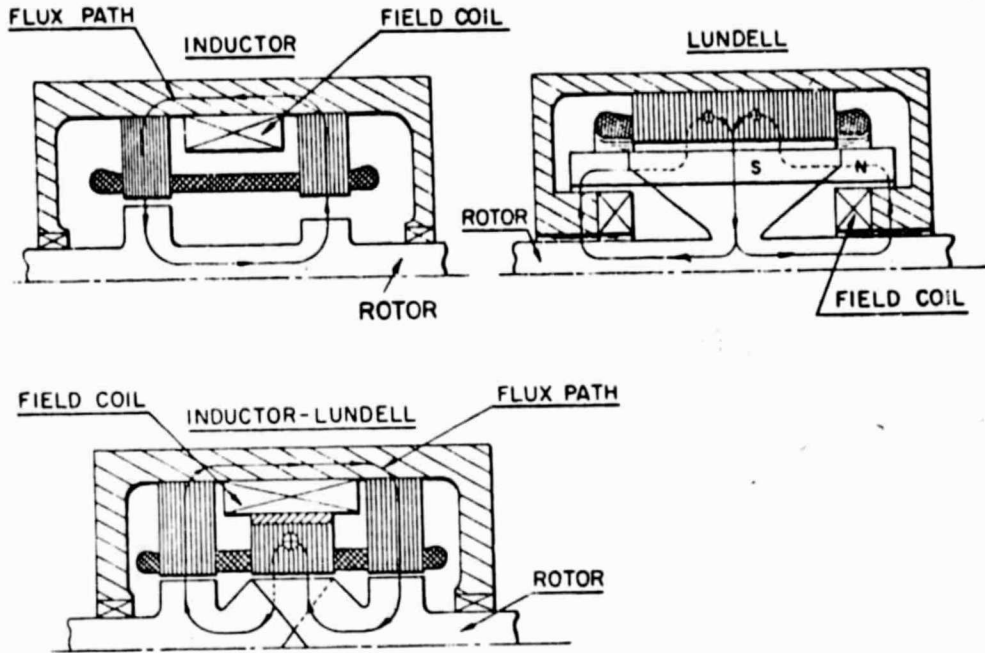
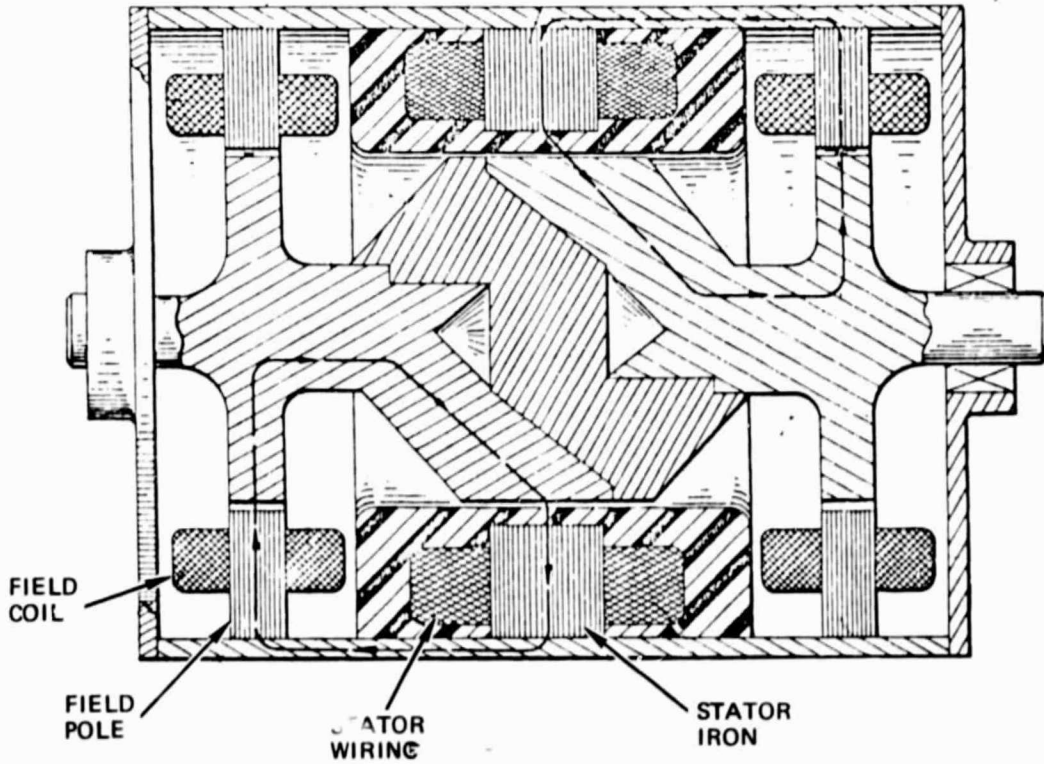

Figure 2-6

Figure 2-7 Nadyne



The above descriptions of flux paths and figures are extracted from patent 3,321,652 on the Dynamo-Electric Machine. Garrett Corporation uses the Rice Alternator shown in Figure 2-8. It has a smooth rotor and uses magnetic insulators between stator flux paths.

Size

The size and volume of the candidate alternator/generators is summarized in Table 2-5. All of the machines considered are multiple phase, multiple winding units that use random or form wound round wire. Losses are lower in the rectifier and electronics portion of the machine with higher voltage. Winding fill factor is lower for the larger number of turns required to yield constant losses between 28, 120, and 300 volts for higher voltage. This increase in winding volume and weight is approximately offset by the terminals. Low voltage requires much larger terminals. On ac machines, the effect of insulated strands or wires of parallel windings reduces the skin effect and resulting eddy currents permits less cross section for constant losses in the machine winding slots and off sets some of the loss of fill factor.

Wound Rotor - Brushless

Many wound rotor liquid and gas cooled units have been built in sizes up to 550 kva at 400 Hz and up to 20 megawatts at 2000 Hz. There are practical rotor dimensions and bearing life limitations that dictate the proper limiting speed. The characteristics are predictable for new designs and there is a large group of manufacturers competent to build variations for future applications. These machines have separate permanent magnet generators for system control and field power.

Permanent Magnet

The permanent magnet machine is sometimes referred to as the transition metal magnet generator and is the smallest in size of the candidate alternators considered for dc. They have been built in sizes up to 45 kW at 270 volts dc and up to 150 kVA output at 2400 to 4800 Hz at 240 volts. The glass like properties of the magnets controls the rotor design and at present limits application of much larger machines.

ORIGINAL PAGE IS
OF POOR QUALITY

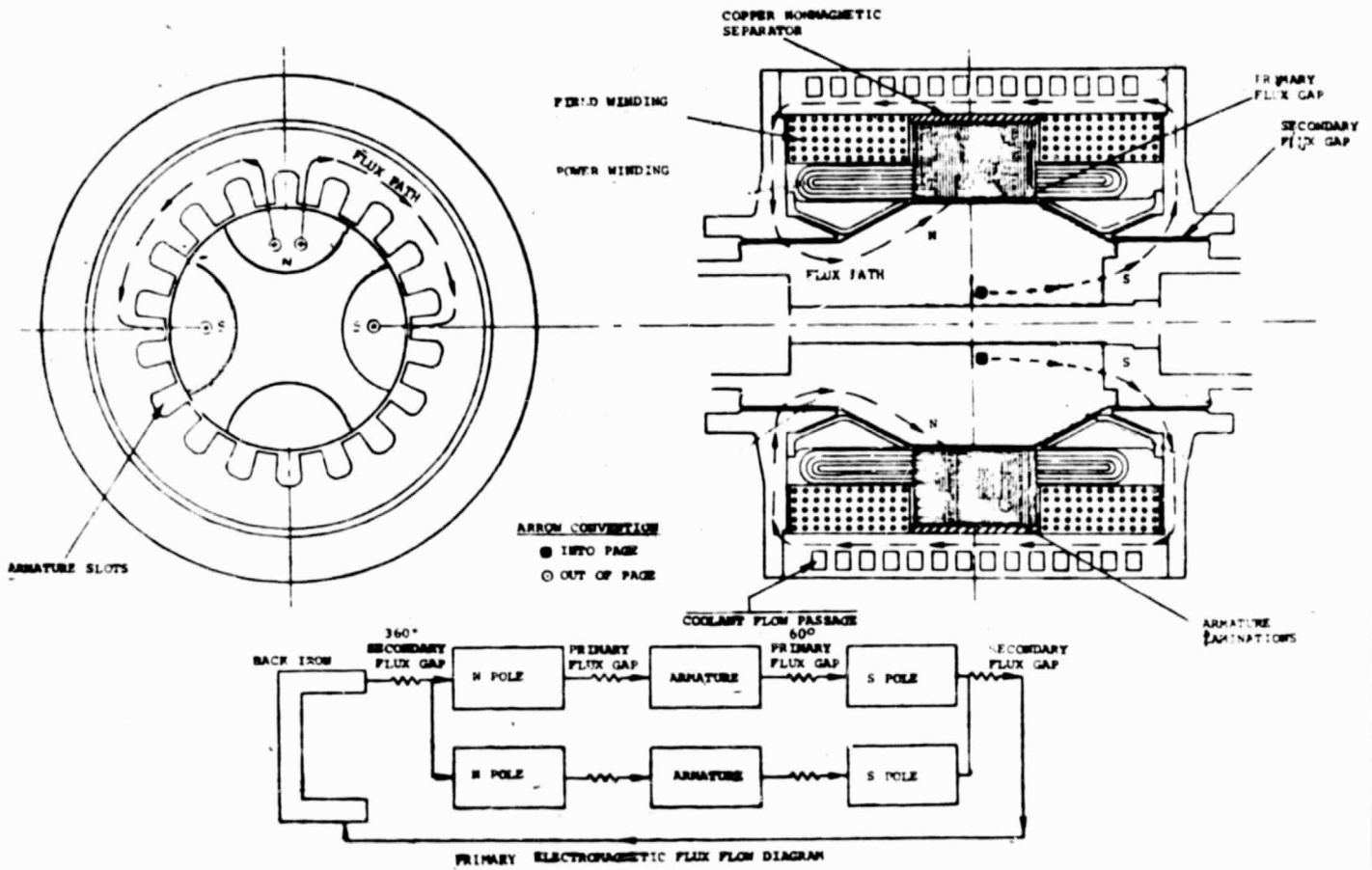

TYPICAL 4 POLE RICE ALTERNATOR

Figure 2-8

Homopolar

The solid rotor construction permits these machines to approach the small size and volume of the permanent magnet type and can be built in ratings of up to 20 megawatts. All of these homopolar machines could be used in 10, 50 or 100 kW rating for 120 or 300 volts dc. The Nadyne alternator has the best characteristics for application. It is more efficient, has a better waveform and is smaller than the Rice machine.

Reliability

The reliability of alternators is mainly determined by the speed which is a function of the number of poles used for the particular bearings selected. There is no significant difference in the machines themselves based on voltage level in the size range of 10 to 100 kW. Machines designed for operation at a constant speed should be more reliable than the machines that are required to operate over large variations in speed. This is because the design for critical speed effects becomes simpler in the vibration design of rotor and bearings. The reliability can be considered equal for machines in this range of sizes provided the speeds are adjusted according to size.

Cost

The cost of the alternators is tabulated for range in Table 2-5 based on estimates for permanent magnet types in these ratings. For the relative cost between types the wound rotor machines are the cheapest and have been built in the largest range of sizes and in large quantities in some ratings. Homopolar machines are the next higher in cost and are substantially more expensive as they have been built for applications requiring unique properties and for low production quantities. The permanent magnet machines are the most expensive but the size and quantities of the units being applied can make a large reduction in cost in the near future.

Table 2-5

SUMMARY CHARACTERISTICS - ALTERNATORS - GENERATORS - RECTIFIERS
 (INCLUDES RECTIFIERS IN STATOR - NOT CONTROLS)

		<u>10 kW</u>	<u>50 kW</u>	<u>100 kW</u>
28 volts	weight/lbs	20	75	125
	volume ft ³	.07	.25	.4
	cost \$/kW	.5k/kW	.3/kW	.2k/kW
120 volts	weight/lbs	18	70	120
	volume ft ³	.06	.2	.35
	cost \$/kW	.4k/kW	.25k/kW	.18k/kW
300 volts	weight/lbs	17	65	120
	volume ft ³	.06	.19	.35
	cost \$/kW	.35k/kW	.24k/kW	.16k/kW

2-23

29817-6001-TU-00

Availability

High cost (low availability) and fragile glass like properties of the transition element magnets prevented broad application of permanent magnet alternators for large kilowatt ratings. G. E. has built units of 150 kva at 20,000 rpm and 2400 to 4800 Hz. Many motors (there are no physical differences in characteristics for motors or generators) in smaller ratings have been built for use from both ac and dc sources. These machines are often called dc brushless motors or generators when in fact they all are ac. The controls do the inverting or rectification depending on the application.

Wound rotor alternators have been built in many sizes and frequencies by many manufacturers. Their characteristics are predictable in 10, 50 and 100 kW sizes. The costs vary a great deal and are mainly due to the sales volume for each design.

Influence on Protection Requirements

For HVDC application, alternators may be used at high frequency using multiple phases and windings which reduces filter volume and weight. Rectification can be located in the stator enclosure with its cooling provisions. The most significant effect on protection is the speed with which turnoff of the power can be accomplished. The next most significant characteristic is the slower response to load changes exhibited by machines with heavily filtered outputs including response to transients. This is influenced by the control electronics, the prime mover and the filtering used.

Fault Current

Alternators have lower subtransient reactance than their steady-state synchronous reactance, which permits delivery of fault currents that are multiples of the normal current for the first few cycles of a line-to-line or line-to-ground fault. This sharp increase in current places high short time stress on the machine windings, but at the same time improves the discrimination and fault isolation capability of the protective equipment that is customarily applied to a generator system and the associated distribution system.

When using rectified dc alternators, this potential benefit of fast discrimination is not reflected to the dc output distribution system. The filterings applied to the dc output reduces the magnitude of the voltage possible in the initial period of a fault and reflects an impedance into the series circuit that adds to the time constant of the transient. This reduces the possible current magnitude for faults on the dc distribution bus and increases the regulation response time of the system with corresponding detriment to the power quality under step load changes. See Appendix A2 comments on current limited sources and prime movers - BIPS/KIPS.

Voltage/Regulation

There are potentially large differences in the regulation response of the candidate alternators. Machines that have field windings could be designed for large magnitudes of field voltage change for faster, better voltage response. The current induced doesn't change correspondingly due to reactance of the field winding. The filters used on the rectified dc bus affects the system voltage response. The inertia and response characteristics of the prime mover reflect into electrical response characteristics. On permanent magnet type machines the normal practice is to oversize the alternator and set terminal voltage output level significantly higher than the steady state full load so that increased load changes can be responded to by initial overshoot of the ac that controls the dc output voltage level. The response possible from this overshoot in voltage is only useful in step load increases and not load removal.

2.1.4 Solar Array

A solar cell converts a portion of the incident solar energy spectrum to available electrical power. The remaining solar spectrum is reflected, or absorbed and reradiated as heat. Typically 11-12% conversion efficiency is attained at low Earth orbit operating temperatures. Crystalline silicon is the predominant conversion material. Growth of the silicon crystal from which the cell wafers are cut limits the size of the cell. Also the voltage produced by a cell is very low - about 0.5 volts. Consequently, many small cells are arranged in a series/parallel matrix - an array - to produce the desired power level and output voltage.

Configuration

A flat, rectangular solar array oriented perpendicular to the sunlight vector is the baseline configuration for the voltage comparisons of this study. The panel is covered with 2 cm by 6 cm (2x6) silicon solar cells. Low resistivity (2 ohm-cm), shallow junction solar cells are employed having an output power of 165 milliwatts per 2x6 cell and operating at 0.475 volts/cell. Approximately 60,000, 300,000 and 600,000 2x6 cells are required respectively for the 10, 50, and 100 kilowatt arrays. Packaging factor experience of .87 (realized on 1-2 kilowatt arrays) indicates total array areas of 890, 4450, and 8900 square feet respectively for 10, 50, and 100 kilowatt outputs. These cell quantities and array areas are independent of the output voltage selected for the array. See Table 2-6.

For 30 volt output, the cells are series connected into strings of 65 cells; 260 cells are series connected for 120 volts; 650 cells for 300 volts. For reliability, each series string will have 3 or more cells parallel connected producing a 65x3, series parallel module. These modules are diode isolated and parallel connected to produce the 30-volt solar array output.

Table 2-6

SOLAR ARRAY
2x6 cm cells

	<u>10kW</u>	<u>50kW</u>	<u>100kW</u>
30 volts			
area ft ²	890	4450	8900
cost \$	500,000	1750,000	2500,000
reliability	.999	.999	.999
120 volts			
area ft ²	890	4450	8900
cost \$	500,000	1750,000	2500,000
reliability	.999	.999	.999
300 volts			
area ft ²	890	4450	8900
cost \$	500,000	1750,000	2500,000
reliability	.999	.999	.999

Size

The desired power output directly determines the total solar cell area and solar cell weight. For a given power, array configuration (round, flat, etc.), substrate design, deployment mechanization and sun orientation influence weight and volume. A direct relationship exists between power and the area of the solar array and hence weight. Substrate technique and deployment mechanization have a secondary effect on weight but a more pronounced effect on volume, especially launch (undeployed) volume. None of these factors are related to array output voltage.

The weight of the solar cell string isolation diodes and the array output wiring is inversely related to voltage. However, higher voltage requires the addition of bypass diodes which offset the weight savings in wiring. The remaining weight effect of wiring is a very small fraction of a 10, 50, or 100 kilowatt array weight. Hence, the weight and volume of a solar array in the 10 kilowatt or larger sizes will be essentially independent of the output voltage at 30, 120, or 300 volts.

Availability

Two manufacturers produce space rated solar cells within the United States: Optical Coatings Laboratory, Incorporated (OCLI) and Spectrolab, Incorporated (Hughes). Other US sources are producing commercial cells. These sources could be qualified to produce space rated cells. Consequently, possible cell production is estimated at 100,000 cells per month: 30,000-40,000 from OCLI, 20,000 from Spectrolab, and 40,000-50,000 from the others. This does not include foreign manufacturing facilities. In addition, the Department of Energy (DOE) has a goal to double solar cell production facilities every year into the 1980's. Therefore, solar cells are considered available in sufficient quantities and at sufficient rates to support production of 100 kilowatt solar arrays.

Shadowing

High voltage arrays have long series connected cell strings. Consequently, if a small portion of a string is shadowed, a back biasing and heating effect occurs on the shadowed cells. This is similar to the interconnect failure reducing the number of parallel cells in a row. Consequently, the same bypass diodes will provide protection and become mandatory on high voltage arrays to tolerate shadowing.

Regulation

Solar cells produce higher voltages when cooler. Therefore, as an array enters sunlight from an eclipse a much higher than normal voltage occurs. Under no load, the voltage approximates 0.625 volts/cell for low Earth orbit. This translates into cold open circuit voltages of 40.6, 163, and 406 volts respectively for the 30, 120, and 300 volt source designs.

These higher voltages occur only briefly and reduce as the array temperature returns to normal sunlight conditions (55°C). Several techniques are available to reduce this voltage. For example, the battery (eclipse energy source) may be utilized to shunt the solar array output and effectively clamp the voltage to the battery charging level until the array warms up. Providing a tapped array for reduced output voltage during this period is also possible. However, array corona protection must accommodate the highest open circuit voltage the array can produce.

Fault current

The solar array is a current limited device. Fault current (short circuit current) from a solar array is limited to 107.5% of the full load (maximum power point) current. Operation of fault protection devices and momentary overload capability is lacking. Consequently, a battery (or other energy storage device) is required to "stiffen" the solar array output.

Safety

A solar array produces rated output voltage if illuminated but unloaded. Hence normal manufacturing illumination will produce full voltage - but low power. A shock nuisance results at the 120 and 300 volt ratings. Careful handling techniques are required to avoid this problem. Output shorting and cell interconnect insulation may be required.

Solar Array Concept for Voltage Regulation

Solar arrays could be provided with series transistors in place of the solar array string isolation diodes. By use of a multiplex control system, each string so switched could be added in parallel as required from a voltage sensing point remote from the solar array. (See Figure 2-9 Conceptual Design of a Solar Array Regulator). This system is a nearly lossless form of power conditioning in that it simply replaces the forward drop of transistors for the forward drop of isolation diodes. The multiplex signals are transported across the slip rings redundantly to provide command gate signals for each solar array string. Slip rings for redundant gate drive power are also required. Bus switching that is often desired for maintenance or changed mode of operation could be accomplished by simple computer command. Bus A or Bus B or both may be used to supply regulated power to independent equipment or operate in parallel. This design overcomes one of the potential hazards of large solar array manned systems. The power may be shut off from coming aboard the spacecraft on demand even when oriented to the sun and illuminated. With large power systems at higher dc voltages as is proposed for SEPS, positive shut off should be a mandatory requirement. The power levels are too high for safety in the event of some mishap or a need to refurbish portions of a solar array wing or slip rings in orbit. The energy of large arrays may be compared to that of a dc welder. The IV curve characteristic of a solar array is just right to sustain arcing and burning if shorted. It would be possible, other than for the safe turn off capability, to use transistors on only a portion of the wings solar cell strings and use diodes on the balance that had the same forward drop characteristics as the transistors.

SCHEMATIC - CONCEPTUAL SOLAR ARRAY

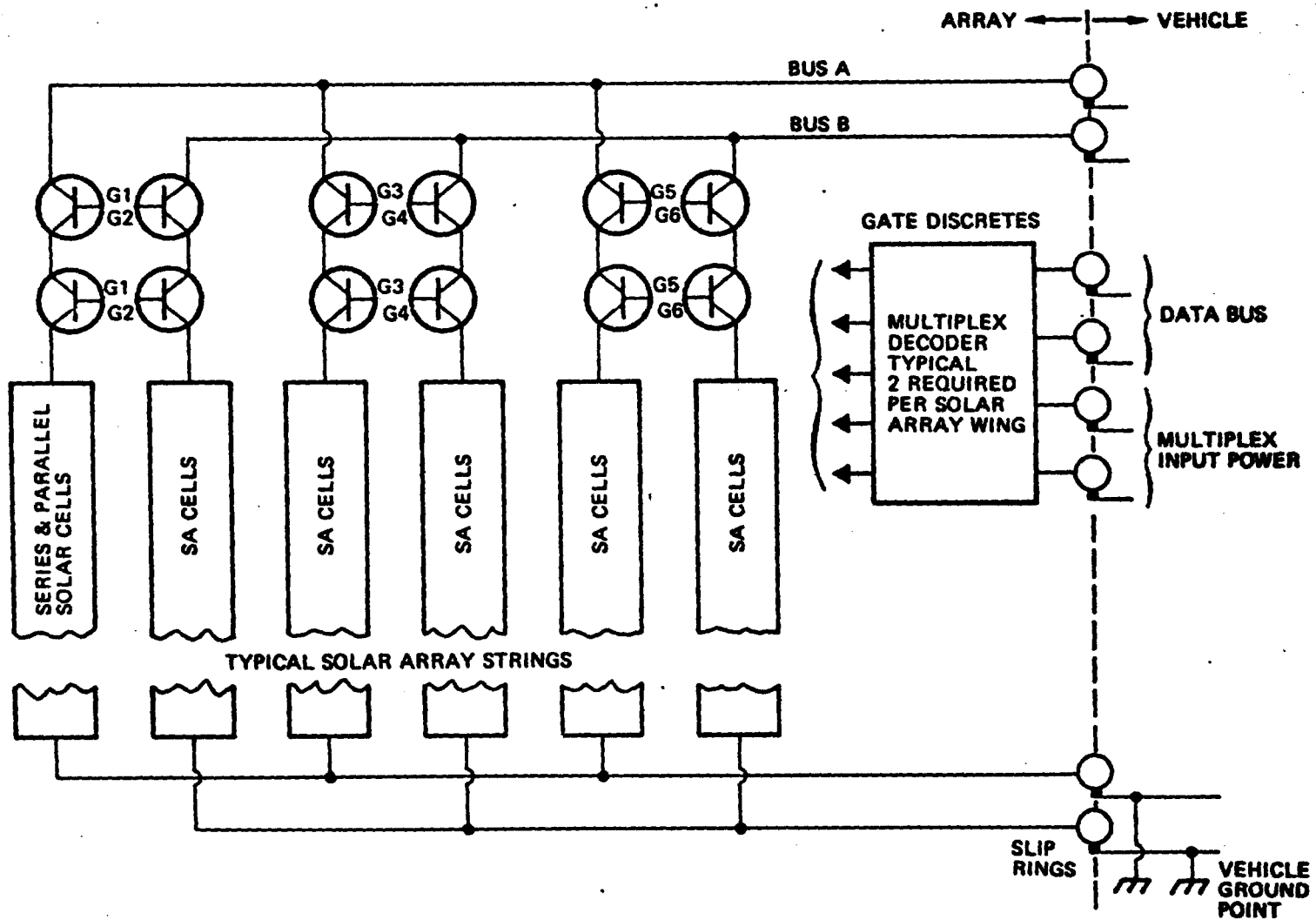

Figure 2-9

2-31

ORIGINAL PAGE IS
OF POOR QUALITY

29817-6001-TU-00

Cost

The major production cost of a solar array is the cell price, the expense to assemble the cell modules and strings (interconnect the cells), and the expense to bond the cell modules to the supporting substrate. Substrate and deployment mechanism production costs are considered a few percent of the array cost. Even development and qualification costs for the substrate and deployment mechanism are relatively modest. No cost relationship is indicated with array output voltage.

Cell prices are presently 5, 11, and 18 dollars respectively for 2x2, 2x4 and 2x6 centimeter cells. The larger, costlier cells require less interconnection and handling expense offsetting the cell price. These presently translate into array costs of \$100 per watt on 1 to 2 kilowatt arrays. Projections for large arrays indicate a specific power cost reduction to \$50/watt or even \$25/watt. For this study, the \$50/watt cost is projected for the 10 kilowatt array, \$35/watt for the 50 kilowatt array, and \$25/watt for the 100 kilowatt array.

Reliability

Solar arrays do not have catastrophic failure modes associated with the cells and interconnects. This is due to the large number of parallel connected elements. For example, the 10 kilowatt array, having only 93 parallel strings yet 650 series elements has a .999774 reliability for 4 or less string failures (open circuit). However, such failure only degrades the power capability by 4.3%. An offsetting increase in initial array size can be incorporated to assure adequate array power over the projected spacecraft life (or refurbishment cycle), or a greater number of smaller cells may be used in parallel to increase the reliability of a specified power level.

A second effect of interconnect failures (open circuit) is to change the load on the remaining cells of that parallel row. In high voltage arrays, if too few cells are in parallel, the remaining cells become reverse biased and dissipate a significant amount of power (-40 volts across cell). An effective means to avoid this problem is to appropriately add bypass diodes in the 120 and 300 volt arrays. Hence, bypass diodes are considered included in the higher voltage arrays.

2.2 Sources Summary

Table 2-7 summarizes the characteristics of the fuel cell, solar array and batteries and comparatively rates the alternators. There is a large range in design differences that makes close comparison of alternators only significant in a comparative sense. Table 2-8 rates the sources in relative merits if they are deemed to be available in those ratings. In a qualitative sense it can be seen that for all power levels considered, the higher voltage level (300V) is preferred.

Table 2-7

SUMMARY - SOURCES

Weight - Volume - Cost - Availability

	<u>Weight</u> <u>lbs/kW</u>	<u>Volume</u> <u>ft³/kW</u>	<u>Cost</u> <u>\$/kW</u>	<u>Availability</u>
Fuel Cell	8 to 35	.02 to .2	25K	yes
Solar Arrays	2 to 6	NA	25 to 50K	yes
Batteries				
NiCd	75 to 100	.02 to .2	30 to 40K	yes
NiH ²	30 to 42	.05 to .5	90 to 140K	yes
Alternators				
	Comparative score (1 Best, 2 Second, 3 Third Best)			
Permanent Magnet	1	1	3	yes
Wound Rotor	3	3	1	yes
Homopolar	2	2	2	yes

2-34

Table 2-8

SOURCES - RELATIVE SCORE BASED ON VOLTAGE AND KW RATING

Characteristics	System KW	Fuel Cell			Solar Array			Battery NiCd			Battery NiH ²			Rect. Alternators		
		28	120	300	28	120	300	28	120	300	28	120	300	28	120	300(volts)
Weight	10	3	2	1	3	2	1	2	1	-	3	2	1	3	2	1
	50	-	2	1	-	2	1	-	2	1	-	2	1	-	2	1
	100	-	2	1	-	-	1	-	-	1	-	-	1	-	-	1
Volume	10	3	2	1	3	2	1	1	1	-	2	1	3	3	2	1
	50	-	2	1	-	2	1	-	2	1	3	2	1	-	2	1
	100	-	2	1	-	-	1	-	-	1	-	-	1	-	2	1
Cost	10	1	2	3	1	2	3	1	2	3	1	2	3	3	1	2
	50	3	1	2	-	2	1	-	2	1	3	2	1	-	1	2
	100	3	2	1	-	-	1	-	-	1	-	-	1	-	2	1
Availability	10	yes	yes	yes	yes	yes	yes	yes	yes	no	yes*	yes*	yes*	yes	yes	yes
	50	no	yes	yes	no	yes	yes	no	yes	yes	yes*	yes*	yes*	no	yes	yes
	100	no	yes	yes	no	no	yes	no	no	yes	no	no	yes*	no	yes	yes
Reliability	10	1	2	3	1	2	3	1	2	3	1	2	3	0	0	0
	50	-	1	2	-	1	2	-	1	2	1	2	3	-	0	0
	100	-	1	2	-	-	1	-	-	1	-	-	1	-	0	0

0 - no difference

1 - best

2 - 2nd best

3 - 3rd best

* Estimate of technology readiness

ORIGINAL PAGE IS
OF POOR QUALITY

29817-6001-TU-00

3.0 Application Analysis

3.1 Manned Spacecraft Power System - A typical manned spacecraft incorporates three independent power systems (Figure 3-1) to provide, as a minimum, mission continuation after one major failure and crew safety after a second major failure of the same type: fail operational, fail safe (FO, FS). This approach accommodates main bus faults and major distribution wiring failures as well as source failures.

A bus tie is included to interconnect the main buses. This arrangement provides for continued power support to a main bus and the associated loads in the event of a source failure (considered more likely than a bus failure).

The engineering intent of this design is to operate each bus independently. Interconnection occurs only upon loss of a power source. However, interconnecting power sources via the tie bus connection is operationally possible and typically occurs. The desired result is to increase the "stiffness" (regulation) of the bus by virtue of load sharing,

to reduce fault damage and to improve power quality. Unfortunately, this stiffness improvement has a concurrent and proportional increase in fault current capability. Unless designed for the 3X source, the fault protection devices are over applied, and spacecraft safety is jeopardized in spite of (or because of) requiring FO, FS redundancy. Consequently fault protection must be adequately sized for actual/total installed (or interconnectable) power capacity.

The Shuttle power system of Figure 3-2 is the basis for this application study of 120 and 300 volt power distribution for 10, 50, and 100 kilowatt sources. The resultant total power system has an installed capacity of 30, 150, and 300 kilowatts, respectively.

ORIGINAL PAGE IS
OF POOR QUALITY

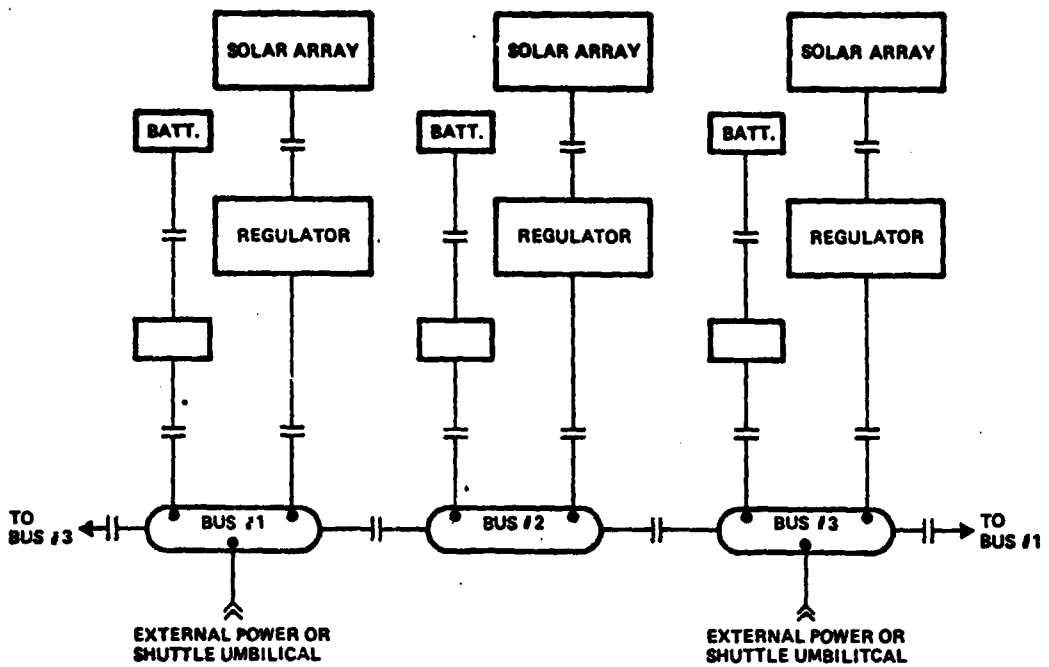

Figure 3-1. Simplified Conceptual Power Module One Line Schematic

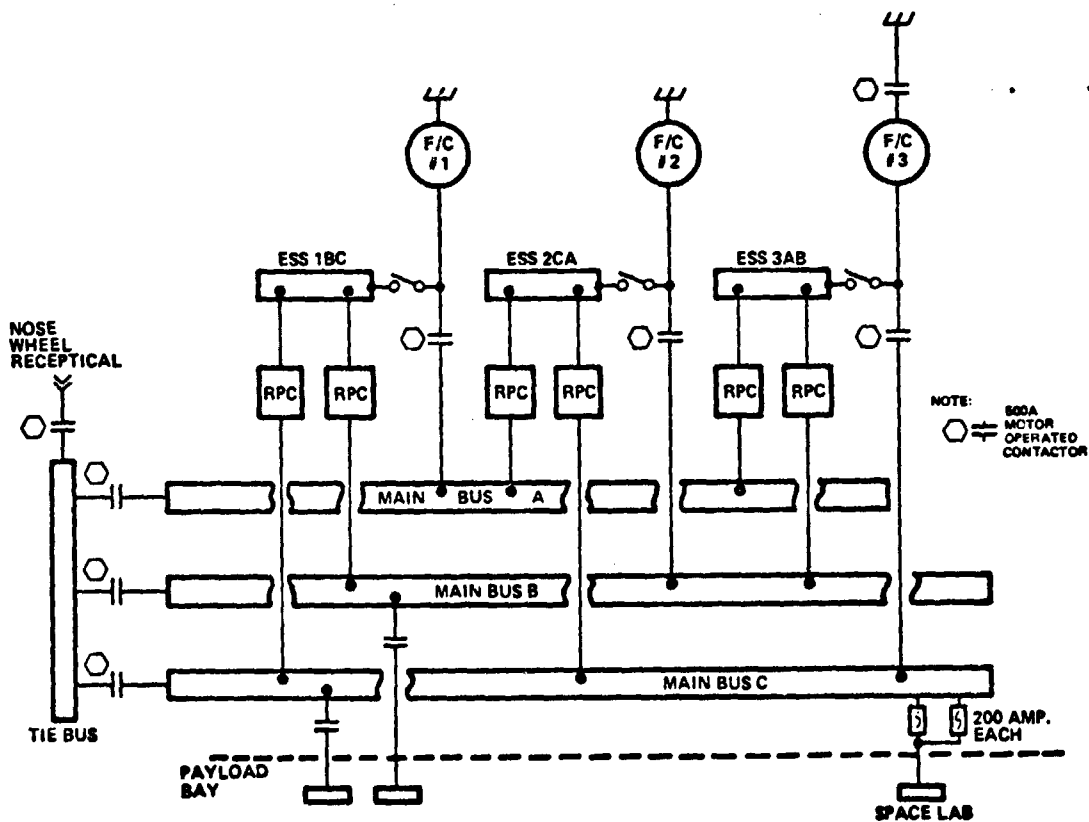

Figure 3-2. Orbiter DC Bus Structure

The power system configuration of Figure 3-1 is formulated based upon the redundancy and safety aspects of a manned spacecraft. No voltage or power level constraint is implied or inherent in the system configuration, assuming adequately rated/designed components are available.

3.2 Power System Components- The elements of a power system consist of the power conversion source, the main bus, distribution feeders, local distribution buses, local distribution wiring, and the associated fault protection devices. A source disconnect switch is also included to allow main bus operation (via bus interconnection) with a failed source.

Power Sources - There are few distinguishing features of higher voltage sources (except batteries) over lower voltage sources of the same power rating (see Section 2.0). Only the final output wiring is significantly different - current and wire cross section (and termination devices) are inversely proportional to output voltage. The significant power system differences related to voltage are in distribution components, not power sources. There is little to recommend selection of 120 volts over 300 volts as a source voltage when considering sources alone.

Battery size, weight, and cost are higher for higher voltages (based on nickel-cadmium cells), and reliability is significantly lower. For large solar array power systems, other energy storage methods need investigation and development.

Wiring Three factors are evaluated in sizing distribution wiring: 1) the wiring cable capacity must support the steady-state load; 2) the wire must be large enough to meet the regulation criteria for distribution voltage drops; and 3) the thermal capacity of the wire must tolerate faults. Each

of these factors is directly related to load current and hence inversely related to system voltage. Therefore, the higher the voltage, the smaller the wire and the less weight incurred for electrical power distribution.

The above is the first order effect. Several second order effects occur:

- 1) There is a practical minimum to which power wiring should be reduced for physical integrity;
- 2) Insulation becomes a greater proportion of wire weight for smaller copper cross section;
- 3) Connector sizes are larger with greater pin spacing for higher voltages; and
- 4) Reduced distribution losses at higher voltages reduce the thermal subsystem heat removal requirements (less weight and cost).

As the system voltage is increased, wire sizes become smaller, but 26 to 22 gage wire is a practical (reliable) limit for twisted pairs of wire. Space ratings of 1 and 2 amperes respectively support up to 100 or 200 watts at 120 volts, and to 270 or 500 watts at 300 volts. Hence, for a number of smaller individual loads, little or no wire size reduction is feasible. However, the greater part of the distribution weight in the 30-volt multi-kilowatt feeders can be reduced by utilizing 120 or 300 volts.

Higher system voltages require increased pin spacing in connectors. The larger pin spacing provides the separation and surface creep distances to accommodate the higher voltages without corona or breakdown. Hence, the connector size and weight increases are only partially offset by the reduction in connector pin size. (For example, 20 gage pins are used instead of 16 gage).

Distribution wiring at higher voltages is reduced nearly proportional to current reduction to maintain wiring thermal and cable load capacities. This is therefore an inverse function of voltage: 30 volts to 120 volts yields a 4 to 1 current, wire size, and weight reduction neglecting the effects of insulation (where not limited by minimum size considerations or oversized for regulation). The distribution resistance for higher voltage is directly proportional to the voltage ratio and the load current is inversely proportional to this ratio:

$$R_{120} = 4 R_{30}$$

$$I_{120} = I_{30}/4$$

As a result, the distribution voltage drop of higher voltage systems is identical to the baseline 30-volt system:

$$\Delta V_{30} = I_{30} \cdot R_{30}$$

$$\Delta V_{120} = I_{120} \cdot R_{120} = I_{30}/4 \cdot 4R_{30} = I_{30} \cdot R_{30}$$

$$\Delta V_{120} = \Delta V_{30}$$

In actual practice, wherein the full wire size reduction proportional to higher voltage is not possible due to minimum gage considerations, the absolute regulation will further improve. This is especially true for local individual load distribution wiring. A greater proportion of the allowable distribution voltage regulation drop may then be apportioned to the main distribution feeders. Consequently, higher voltages produce proportionally reduced weight, greatly improved distribution regulation, and a better allocation of regulation voltage drops. A 300-volt system has more growth potential (power increase) for less system weight, and the 120-volt system is superior to a 30-volt system.

In those cases wherein the distribution wire is sized by regulation allowables, a more dramatic wire size and weight reduction is possible. Assuming a proportionally increased regulation voltage drop for the higher voltage system, wire sized by regulation allowables has a potential for reduction by the square of the voltage ratio. For example, a 120-volt system will have an allowable voltage drop for distribution of four times that for the 30-volt system. Hence, the allowable distribution resistance is 16 times that of the 30-volt system:

$$\begin{aligned} \text{Allowable } \Delta V_{120} &= 4 \cdot \Delta V_{30} \\ \Delta V_{30} &= I_{30} \cdot R_{30} \\ \Delta V_{120} &= I_{120} \cdot R_{120} = I_{30}/4 \cdot R_{120} = 4 \Delta V_{30} \\ I_{30}/4 \cdot R_{120} &= 4 (I_{30} \cdot R_{30}) \\ R_{120} &= 16 \cdot R_{30} \end{aligned}$$

Consequently, this distribution wire weight is reduced to 1/16 of the 30-volt system. An actual system will have a combination of these wiring situations: little reduction, direct ratio reduction, and square of the voltage ratio reduction. Weight is correspondingly reduced, with an overall projection essentially proportional to the increased voltage at 120 and 300 volts for the 50 and 100 kilowatt power levels.

A significant additional advantage of higher voltage (reduced current, better regulation) is the direct reduction in heat generated in the distribution wiring and junction boxes. The proportionally reduced heat rejection requirement of switching elements and cable runs is an important consideration as convective heat rejection, paramount to cooling similar terrestrial devices, is absent in zero gravity/vacuum conditions.

Fault Protection - The philosophy of electrical power system fault protection is to protect the power source and distribution wiring for continued useful service. Any load protection thereby introduced is incidental. Consequently, the source fault capability, fault clearing devices, and various levels of distribution wiring must be logically coordinated to preclude propagation of a fault or its effects.

Three specific levels of fault protection are herein considered: source disconnect, main bus connection (feeders), and local load distribution bus connections. Each level has differing requirements to fulfill for fault protection. The source disconnect has to carry very high normal load currents and must rupture the source fault capability. Feeder fault protection devices carry somewhat lower normal currents, but the fault rupture capability must include the sum of the installed sources (for bus tie conditions wherein the sources are effectively paralleled) and consider the fault current return from other load feeders. Local distribution bus fault protection devices have much lower ratings for normal loads (current carrying capacity), but also must rupture the local distribution bus fault current capability. Reduced fault current rupture capacity at the local distribution bus is tolerable to the extent that the feeder from the main bus to the local bus provides a significant (but very low) resistance. The fault current capability of the local distribution bus is thereby reduced, and the rupture requirement on the individual load distribution devices is equally reduced.

Maximum fault currents, and consequently specified current rupture requirements, are inversely proportional to the system voltage. However, maximum fault currents occur with minimum source output voltage. A

potentially more severe rupture requirement occurs for fault conditions representing maximum power transfer from the source. Under this condition, the fault capacity and rupture requirements are related to source type and power rating, rather than being voltage sensitive (in the 30 to 300 volt range). Hence, the true fault capability and the resulting rupture requirements increase directly with power generation capacity.

Circuit breakers and fuses are typically the fault protection devices for aircraft and low power satellites. Contactors, power relays, and power transistors have also been used when coupled with overcurrent detection and "off" command circuits. These devices (except the transistor) employ a physical air gap to clear a fault. In the 10 to 100 kilowatt range of this study, no such devices are extant for space application (hard vacuum, zero gravity). Terrestrial devices exist, but they depend upon air for arc extension, cooling, and consequent extinction. Magnetic blow out devices are also employed, but to speed up this process of extension, cooling, and extinction. (Magnetic blowout devices can fail to extinguish an arc for a relatively low fault currents which produces inadequate magnetic forces).

Commutation can be employed to reduce the fault current to zero during fault clearing. If the zero current condition is maintained adequately long, the arc extinguishes, and rupture is accomplished. Alternating current at low frequency (400 cps or lower) inherently assists in accomplishing this task. (Higher frequencies do not maintain zero current for sufficient duration to allow deionization to occur, and the arc restrikes upon voltage buildup.) Commutation with direct current systems requires electrical energy storage devices such as capacitors or inductors which are inherently large. These can be depleted due to the fault before arc extinction has occurred. Hence, direct current commutation at the power/energy levels of this study is not attractive.

Semiconductor devices have been developed for power switches - transistors or silicon controller rectifiers (SCR). They are sensitive to voltage transients, are relatively inefficient (compared to contact closure), are limited by the voltage and current ratings of available semiconductors, and have significant leakage current in the larger power ratings even when "off". Transistors provide the greatest promise - lower conducting losses (than SCR's) and potentially could limit fault currents to controllable levels (1.5 to 10 times normal full load rating). Silicon controlled rectifiers depend upon commutating energy storage for high power current interruption, have larger conducting losses (than transistors), and conduction time limited fault currents. Present limitations are on the semiconductor chip - voltage and current ratings.

Vacuum Switches offer a possible interim solution to high-current, high-voltage fault protection on direct current power systems. The vacuum switch does rupture large currents at high voltages. Arc extinction (current rupture) is very rapid, and very large voltage transients result. Fast acting voltage transient suppression is required that will handle inductive fault currents. Large diodes may be suitable if turn-on times are sufficiently short.

The vacuum switch is an interim solution as each current rupture erodes electrode material and redeposits the vapor on the enclosure walls. Life is limited - nominally a hundred rated current ruptures. However, a long duration useful life can be realized if the vacuum switch is used for fault protection only and normal load switching is accomplished by other devices. For example, consider the vacuum switch employed as a power source disconnect. Normally the bus loads are terminated prior to disconnecting the source. Hence, the power source disconnect does not normally rupture current - only in the event of a failure or fault. Then the limited rupture life of the vacuum switch is adequate for this application as it provides an economically useful life. Similarly, it could be suitable for the bus tie interconnects and for main feeder protection if proper transient devices were coordinated with each vacuum switch.

Power Return - System factors make the use of single wire systems a poor practice. The shared return path (common mode impedance) introduces voltage changes (transients, noise) that may be detrimental to some sensitive circuits. To work satisfactorily, a very low resistance is required in the structure return. Such low resistance cannot be assured in future spacecraft since structures using lightweight laminations, graphite/boron fibers, and honeycomb panels with epoxy bonded secondary structure are increasingly prevalent. Single-wire, structure-return systems have had some use on aircraft and some use on spacecraft, but even with only a few such circuits of this configuration on the shuttle, effects on experiments and payloads are objectionable.

Ground fault detectors and isolators are suggested for safety (Section 4.0), on the higher-voltage high-power systems. For their use, a two wire system, employing return wiring and a single grounding point, is mandatory.

3.3 Shuttle Payload Support - The Shuttle is recognized as being limited in power support capability for payloads. Therefore, the candidate power sources of Section 2.0 (10, 50, and 100 kilowatts) were considered at 120 and 300 volts as payload power sources. Only limited attention was given to other support subsystem consequences in terms of fuel supply, thermal control, efficiency, and total Shuttle weight, volume, or cost. Any of the candidate power source types considered can be used, though they are not interchangeable for various pertinent characteristics. In terms of power handling capability, there is little to recommend selection of 120 volts over 300 volts. By using 300 volts, a greater range of load can be accommodated with lighter weight feeders and interface connections on the Shuttle. Independent sources and buses, sized to the limit of the available switching and protection technology, is the recommended approach to utilization of 300 volts (or 120 volts) for Shuttle payloads.

Payload Power Distribution Characteristic

Characteristics required of Payload power distribution systems in space are:

- 1) Sources of power with output voltage regulating capability via remote sensing.
- 2) Distribution hardware including contactors, power relays and RPC's with circuit breaker equivalent functional capability for use as main bus switching and protection. These have to provide rupture capacity equal to the worst-case capability of the source(s) and loads operating at one time. When sources are provided with ability to operate in parallel, the fault contribution increases proportionally and all main bus protection devices should safely provide wire and bus integrity for faults.
- 3) Acceptable efficiency measured in the context of the total system, i.e., source, distribution, loads.
- 4) Knowledge of the loads in terms of its contribution to system rupture capacity requirements, tolerances to voltage variation including transient tolerances to voltage variation and their cost, weight and volume trade offs driven by these characteristics.
- 5) A system concept for complexity, distance of source to loads and kilowatt requirements.
- 6) The least modification and tare weight to the Orbiter practical for support of payloads with flexibility for yet undefined payloads.
- 7) Load protection hardware should be designed and tested for capability for withstanding the worst-case fault current including the magnetic forces induced by that current as well as the transient thermal effects.
- 8) The I^2T ampere ampere second capability of main bus switches must be designed for backup of failed load protection devices.
- 9) All power system protective equipment should be selected with full awareness of the collective short circuit capability of the sources, the combination of the loads and the transient characteristics of the distribution equipment.

Possible Shuttle Distribution Modifications Candidate Power Sources

Independent sources and busses sized to the limit of the available switching and protection technology capability is the recommended approach to utilization of 120 or 300 volts to Shuttle Orbiter Payloads. Any of the candidate power sources considered in this study can be used, though they aren't totally interchangeable for all pertinent characteristics. Regulated voltage using voltage sensing at the main power delivery bus has the greatest potential for accommodating the variable distances and load ranges that could be required for use in the Shuttle cargo bay. If this power system is solar array powered, it is anticipated it would be on a power module external to the main bay and at considerable wiring distance from experiment locations. By using 300 volts measured at a remote regulated bus, a greater range of load could be accommodated with lighter weight umbilicals and feeders on the Orbiter.

Components

Components (without significant development) are not available to mechanize space distribution systems at 50 or 100 kW at any dc voltage. Potential exists to provide switching components that are tailored to any discrete load or group of loads sharing similar short-term stored energy characteristics. Above the current and voltage capability of transistor pass element switches, commutation devices must be employed with the power switch to provide normal and fault turn-off capability the main safety minimum requirement of any flight system. Diverse unpredictable mixtures of utilization equipment (inductors, capacitors, resistors, motors) might prove unworkable. Switches designed to commutate the source current to "off" which is additive to the current delivered by the stored energy of the loads are not simple devices that perform for any level of normal load and any fault.

Problems of Augmenting Power Delivered to Orbiter Main Busses

Delivery of power from or to a payload distribution system at the present Orbiter main bus voltage of 28 Vdc should consider these identified complications:

1. Fuel cells are not regulated and transisiton from parallel to isolated operation should provide transient free operations for the loads. See Figure 3-2.

2. Orbiter fuel cells are normally never turned completely off in space. Their least power consumption level is set to assure that reactants do not boil off as would occur if consumption from any reactant storage tank were stopped for any prolonged period.
3. A single fuel cell has delivery capability for 6000 ampere to its own bus. Parallel fault current delivery from two fuel cells could approach twice this value. See Figure 2-3.
4. Fuel cell switching to and from its bus or tie bus is provided by manually initiated control switches that power motor operated contactors rated 500 amperes continuous and 6000 amperes rupture. The maximum transfer time is specified as 100 ms. The motor switches have a leakage rate of 5×10^{-7} scc/sec per cubic inch of sealed volume (20 in^3) that will limit their use on prolonged stays in orbit. The possible effects of fault switching are not adequately factored into the projected performance of the contactors leakage rate or capability at degraded internal gas pressures.
5. There is no automatic load shedding on fault sensing provided to the Orbiter main busses.
6. None of the Orbiter active dc load main bus switching devices has been specified and tested to the limit of their present application in terms of rupture capacity. (See discussion in Section 6.2 on switching components.) The application should consider the contribution of two fuel cells in parallel plus an allowance for loads returning current to a fault. The calculated I^2T ampere ampere second potentially possible without any load contribution to a fault in the motor contactor operating times of 100 ms is 3.6×10^6 ampere ampere second and is 14.4×10^6 ampere ampere second for two fuel cells in parallel. The thermal damage potential of such energy would melt a 1/0 copper conductor in approximately ten seconds from one fuel cell and in two seconds from parallel capability.
7. Power distribution J-boxes used for fuel cell main busses are full of equipment and do not offer prospect for containing recommended additional bus termination hardware. None of the main J-box protection components except RPC's have been designed for cold plate cooling and use in hard vacuum.
8. Fuses are inherently broad tolerance devices and when selected to pass normal currents with a minimum margin for false operation, they act as heaters with significant system losses. They are very temperature dependent for characteristic and when fuses are used in parallel, the tolerances usable for application have to be increased.

9. The best location for additional main bus power conditioning equipment to distribute power to Orbiter Payloads is in the fuel cell main bus distribution J-box on a cold plate. By use of higher voltage in Payloads, this could permit the least wiring and total Orbiter tare weight, volume and efficiency penalty. In Space Lab the buck regulator is remote from the bus. Use of a regulating dc to dc converter at the Orbiter fuel cell bus equipped with remote bus voltage sensing could provide up to 12 kW of quality power to remote Payloads in the Orbiter bay. Payload crew and Orbiter crew should both be provided with supervisory control of Payload converter output. By tailoring the J-box installation of the converter and its protection switching equipment as a package, the unit could be removed from the Orbiter on flights that did not require it for support.

Power Module to Orbiter Wiring Configuration

To illustrate the effect of voltage and power level on the wiring weight for 120 and 270 Vdc, a detailed analysis of an umbilical connection between a Power Module and an Orbiter bus was made for 28, 120 and 270 Vdc in two different circuit configurations for each voltage. The Power Module to Orbiter umbilical schematic (Figure 3-3) indicates the wiring assumed between the Power Module and the Orbiter.

The effect of voltage and power level on wiring weight was compared based on the circuit shown in Figure 3-3 for the routing diagramed in Figure 3-4. Two bus configurations were used; a single bus and a dual bus.

Appendix Table A2-1 summarizes the wire weight and voltage drop for the umbilical. Table A2-2 shows the connector weights. Power levels of 10, 50 and 100 kilowatts were considered with 25 percent additional for peak demand.

Wire was nickel plated, fine stranded wire per MIL-W-81381/4. For connector weight extrapolation was required since connector catalogs do not delineate weights for all the extensive configurations possible for each connector type. For use of large pins up to 1/0 gage, Bendix type QWLD connectors were estimated to be increased to allow for heavier wall thickness of heavy duty connector shells. No attempt was made to account for the heavier weight of hermetic sealed connectors which are required at pressure bulkheads.

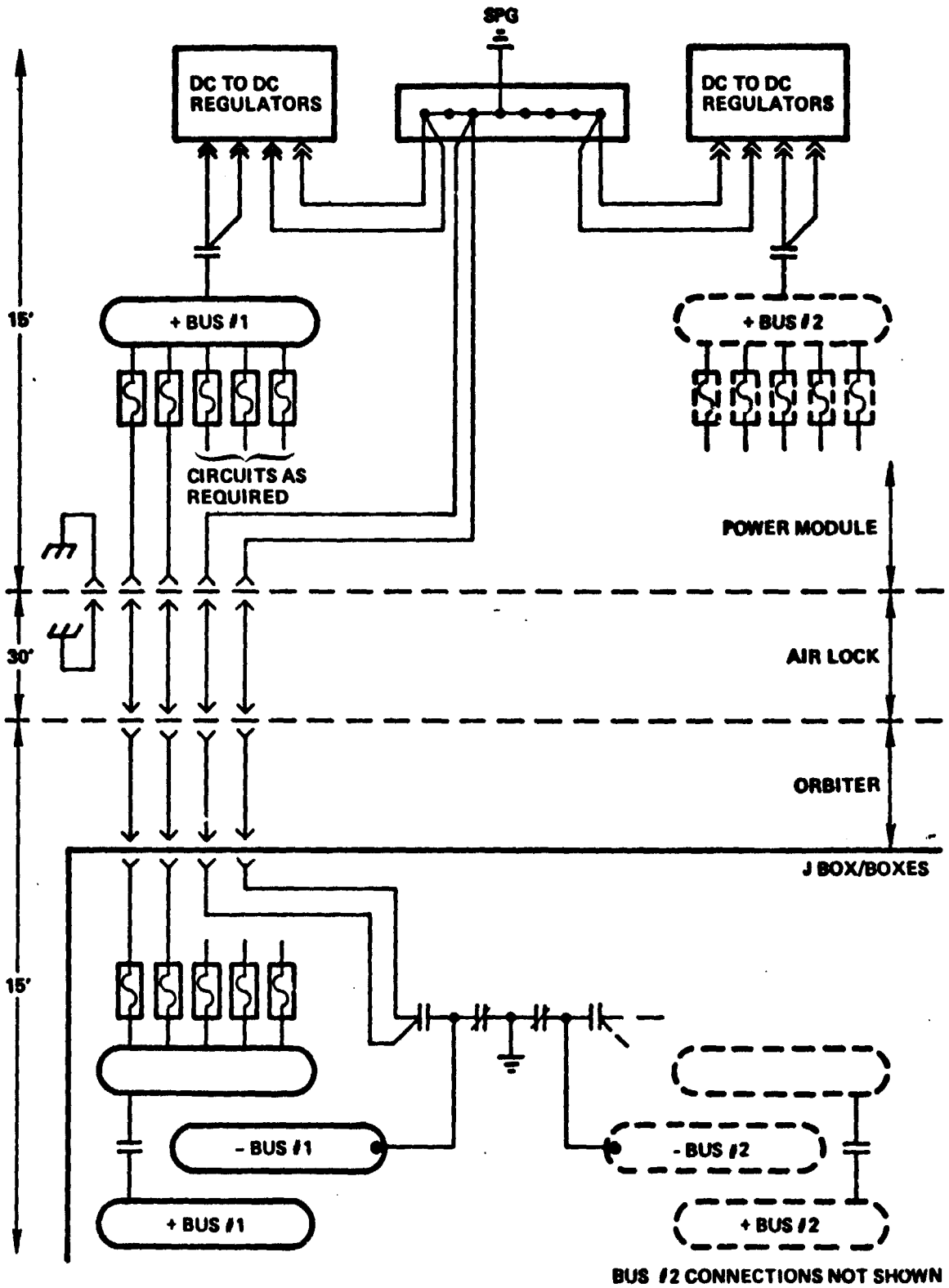

Figure 3-3. Power Module to Orbiter Umbilical Schematic-
Analysis Basis

Delivery of 50 and 100 kW average power was presumed based on conceptual contactors and protection scheme development. No weight was included for the Orbiter J-box or for the cooling provision required in the Orbiter or the Power Module. These are required redundantly and are roughly penalties that are proportional to kilowatts of power provided.

To provide for predictable fault current paths, the Orbiter bus ground connection was mechanized to the Power Module single point ground. Structure bondwires of not less than 50 percent of the conductor cross section of the supply positive circuit were included and bonded in both the Orbiter and Power Module to the structure. Fuses and fuse holders were based on MIL-F-5372 fuses. Fuses and contactors should be designed for cold plate cooling to be compatible with the system assumed. Fuses have to be closely coordinated with the capacity rating of the wires they protect. Compromises are required between the threshold providing no nuisance trips and the insulation damage

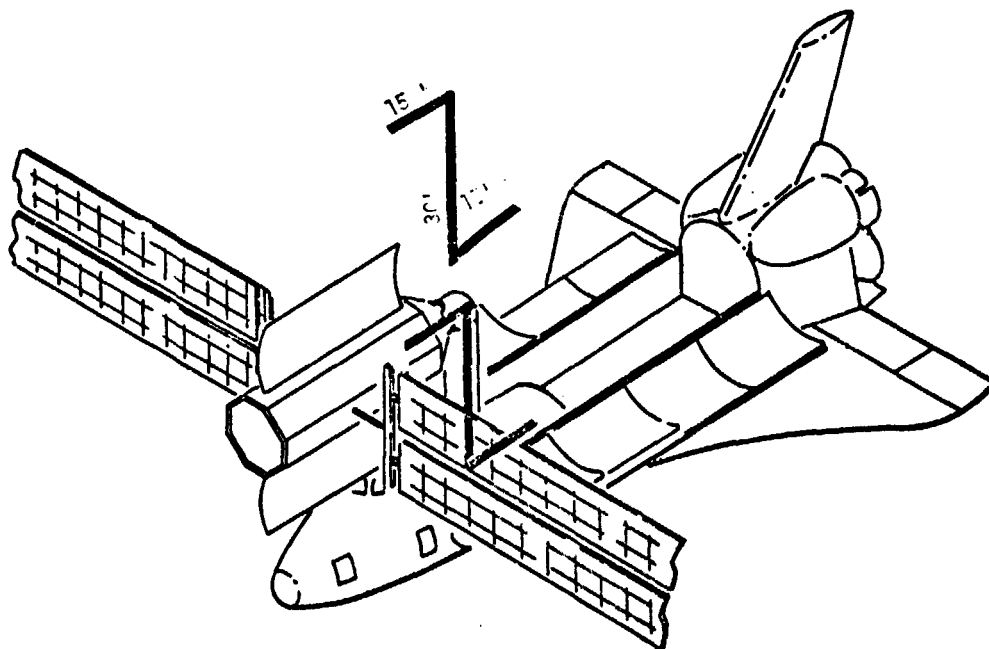

Figure 3-4. Power Module to Orbiter Umbilical Routing

resulting from single conductor faults. Fuses located in hard vacuum that are carefully coordinated to the peak normal sustained current of the circuit need to reject more heat than over sized fuses would. The wire depending on how it is selected can reject its heat into the fuse complicating the coordination task. Distribution J-boxes that contain fuses, contactors and busses run hot. Cooling electrical equipment while providing adequate electrical insulation requires use of circulating coolants.

Contactors weight and volume were estimated. No production units are available for this application. To provide for rupture capability, commutating capacitors and inductors were assumed to be integral with the contactor in some hybrid fashion. Actual operation times or rupture capacity for such units is unknown. It is possible to tailor these components to the discrete system capability, but this defeats interchangeable contactors on different capacity systems.

The control wiring was assumed to be two umbilicals carrying three twisted pair shielded wire data busses for multiplex control of contactors from command control signals in the Power Module or the Orbiter or both. No weight was tabulated for in/out multiplexer boxes in support of this system.

The voltage drop is the sum of the IR of the wire at 50°C and the one percent loss assumed for each fuse (two percent per positive wire; one fuse in the Power Module bus and another in the Orbiter J box).

The wire lengths are based on 15 feet between the Power Module regulator and the Power Module fly-away interface. 30 feet is assumed for the air lock umbilical and another 15 feet is required to transition from the lower air lock entrance to the J-box for Orbiter payloads.

The bus voltage on the Orbiter bus is sensed at the bus and referred to the Power Module for voltage control. The Power Module to Orbiter umbilical weights are plotted in Figure 3-5 and tabulated in Table 3-1.

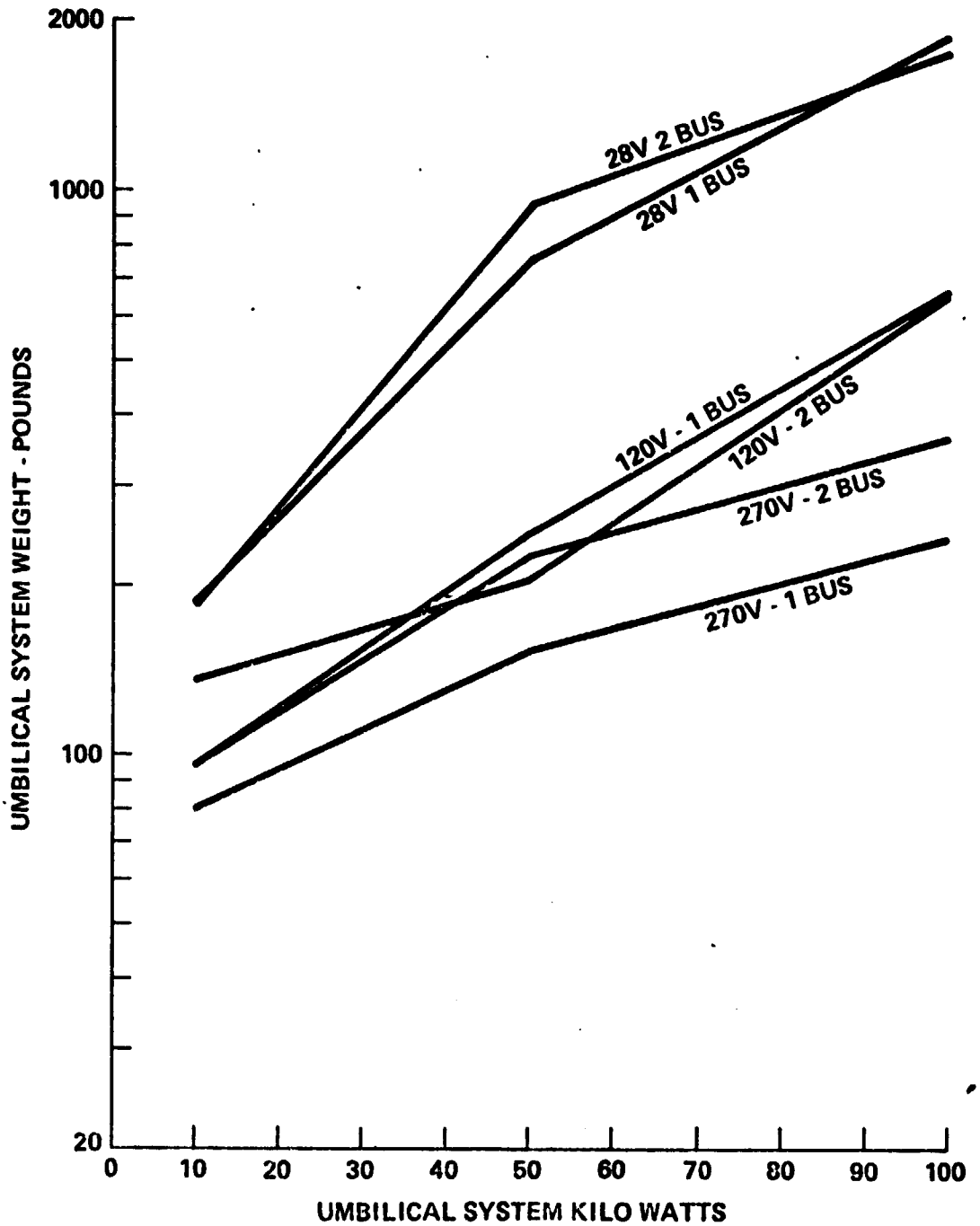

Power Module to Orbiter Umbilical Weight for 28 Volt, 120 Volts and 270 Volts V_S Kilowatts

POWER MODULE AND ORBITER UMBILICAL WEIGHTS IN POUNDS

	10/12.5kW			50/62.5kW			100/125kW		
	PM	O	TOTAL	PM	O	TOTAL	PM	O	TOTAL
One Bus - 28V									
Wire (power)	79.6	22.4	102	397	112	509	793.3	223.7	1017
Connectors	15.2	10.4	25.6	76	60.8	136.8	152	104	256
Contactors	6	12	18	50	100	100	80	160	240
Fuse/Holder	.72	.72	1.44	1.08	1.08	1.16	2.16	2.16	4.32
Control Wire	8	8	16	8	8	16	8	8	16
Structure	16.4	8.3	24.7	80	42.3	122.3	155.3	74.7	230
Total	125.95	61.82	187.7	612	324.2	936.3	1190.8	572.6	1763.4
Two Bus - 28V									
Wire	64.4	182	82.6	405.6	114.4	520	882.2	248.8	1131
Connectors	22.8	15.6	38.4	38.4	26	64.8	68	52	120
Fuse/Holder	.92	.92	1.84	3.6	3.6	7.2	7.2	7.2	14.4
Contactors	8	16	24	60	120	180	100	200	300
Control Wire	8	8	16	8	8	16	8	8	16
Structure	15.6	10.6	26.2	77.3	23	100.3	159.8	77.4	237.2
Total	119.7	69.3	189	592.9	176.2	769.1	1225.2	593.4	1818.6
One Bus - 120V									
Wire	20.9	5.9	26.8	88.2	24.9	113.1	237.9	67.1	305
Connectors	9.5	6.5	16	19.2	11.2	30.4	40.8	31.2	72.0
Fuse/Holder	.48	.48	.96	1.08	1.08	2.76	1.8	1.8	3.6
Contactors	8	16	24	18	36	54	50	100	150
Control Wire	8	8	16	8	8	16	8	8	16
Structure	7	5.5	12.5	20.2	12.2	32.4	50.8	31.2	82
Total	53.9	42.4	96.3	154.7	145.5	248.1	389.3	239.3	628.6
Two Bus - 120V									
Wire	15	4.3	19.3	64.4	18.2	82.6	317.5	89.5	407
Connector	7.6	4.6	12.2	15.2	10.4	25.6	27.2	20.8	88.8
Fuse/Holder	8	8	1.1	1.2	1.2	2.4	2.88	2.88	5.76
Contactors	20	40	60	16	32	48	36	72	108
Control Wire	8	8	16	8	8	16	8	8	16
Structure	8.8	8.6	17.4	15.7	10.5	26.2	58.7	149	87.7
Total	67.4	66.3	133.7	120.5	80.3	200.8	450.3	222.1	672.4
One Bus - 270V									
Wire	4.8	1.4	6.2	32.2	9.1	41.3	79.4	22.4	101.8
Connector	9.5	6.5	16	19.2	11.2	30.4	15.2	10.4	26.5
Fuse/Holder	.6	.6	1.2	.72	.72	1.44	.96	.96	1.92
Contactors	10	20	15	15	30	45	30	60	90
Control Wire	8	8	8	8	8	8	8	8	8
Structure	5	5.5	10.5	11.3	8.8	20.1	20	11.9	31.9
Total	37.9	42	79.9	86.4	67.8	154.2	153.6	91.3	244.9
Two Bus - 270V									
Wire	9.7	2.7	12.4	41.8	11.8	53.6	64.4	18.2	82.6
Connector	3.8	2.6	6.4	19	13	32	22.8	15.6	38.4
Fuse Holder	.6	.6	1.2	1.44	1.44	2.88	1.92	1.92	3.84
Contactors	16	32	18	30	60	90	60	120	180
Control Wire	8	8	8	8	8	8	8	8	8
Structure	5.7	6.9	12.6	15	14.1	29.1	23.6	24.6	48.2
Total	43.8	52.8	96.6	115.3	108.4	223.7	180.7	188.2	369

Table 3-1

Relative umbilical weights for the Power Module and Orbiter are plotted in Figure 3-6 for single and dual umbilicals. From inspection of the tabulated weights of Table 3-1, it can be seen that scar weights to the Orbiter for use of 28 volts could be significantly reduced by the use of power conditioning equipment for down converting from 120 or 270 volts. Further, the actual distance to Payloads from Orbiter J boxes can add substantially to scar weight to the Orbiter if higher voltages are not utilized.

Trends in Wiring Configurations

The crew's location had been the traditional location for distribution busses as this gave them access to the manual circuit breakers which in many instances were used as on/off switches. In more modern, larger vehicles the trend is to establish many distribution busses located between the source of power and the utilization equipment and the circuit breakers are either remotely operated or are in series with a relay or contactors that are remotely operated.

The next generation of manned spacecraft will be built functionally with many distribution busses located central to groups of equipment and control will be by redundant data links. This has large economics in wiring weight due to the shorter power wire runs, but this is not the major design driver for the system configuration. As systems become more complex, crew tasks have to be reduced and computer controlled multiplexed systems will provide monitoring and display as well as discrete address control. The crew can select a mode of operation that has preprogrammed sets of switch and circuit breaker configurations that can be then all positioned for the selected mode and verified automatically. The crew only sees the verification or the display of the discrepancy.

ORIGINAL PAGE IS
OF POOR QUALITY

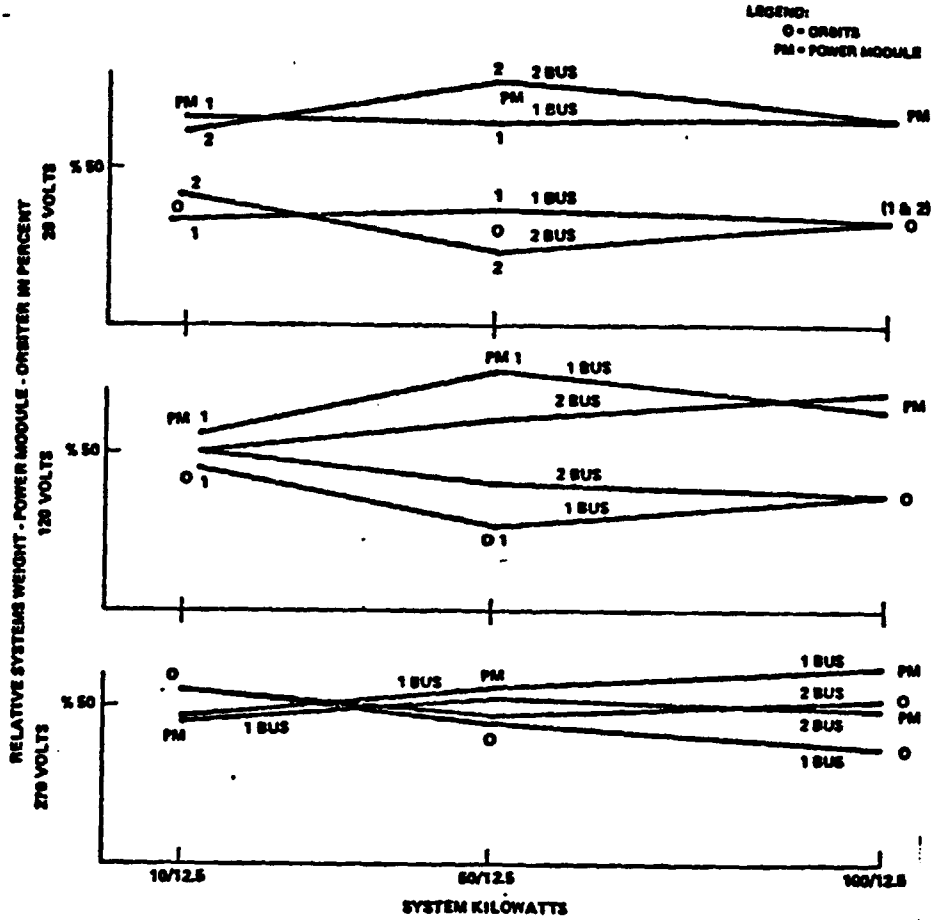

RELATIVE UMBILICAL WEIGHTS FOR POWER MODULE
AND ORBITER AS A FUNCTION OF VOLTAGE AND POWER
LEVEL FOR 1 AND 2 BUSES

Figure 3-6

Other Wiring Considerations

The power transmission capability of two wire and three wire alternatives is summarized in Figure 3-7 for three different voltage levels. Bipolar ac configurations are included for the sake of completeness.

Two Wire Configurations

In two conductor configurations, dc is more capable for power transmission than ac for any voltage level. Higher voltages improve conductor power transmission capability. Bipolar three wire dc configurations transmit more power per unit of conductor but are not good power distribution practice as the current in both source conductors is additive and result in large magnetic signatures which is a source of EMI.

Three Wire Configurations

Ac is more capable than dc when in a three or four wire configuration. In large systems, main busses and feeders to distribution busses are best in terms of wire weight and voltage regulation if three phase. Penalties occur in the distribution bus to utilization equipment conductors when compared to dc, but the trend in using distributed power busses where the two conductor wire runs are short offsets this penalty.

Grounding

System factors make use of single wire systems a poor practice due to the shared return and the effect of voltage changes induced in some sensitive circuits. To work they must have a low resistance in the structure return. This cannot be assured in future spacecraft since structures using light-weight laminations and honeycomb panels with epoxy glued secondary structure are increasingly prevalent. Structure return single wire systems have had some use on aircraft and spacecraft, but even with few such circuits of this configuration on the Shuttle Orbiter, induced effects on experiments and payloads is objectionable. Ground fault detectors and isolators are recommended for added safety and for their use a single point grounding system is required.

Per Unit Power Transmission Capability (28V, 2 Wire = 1PU)

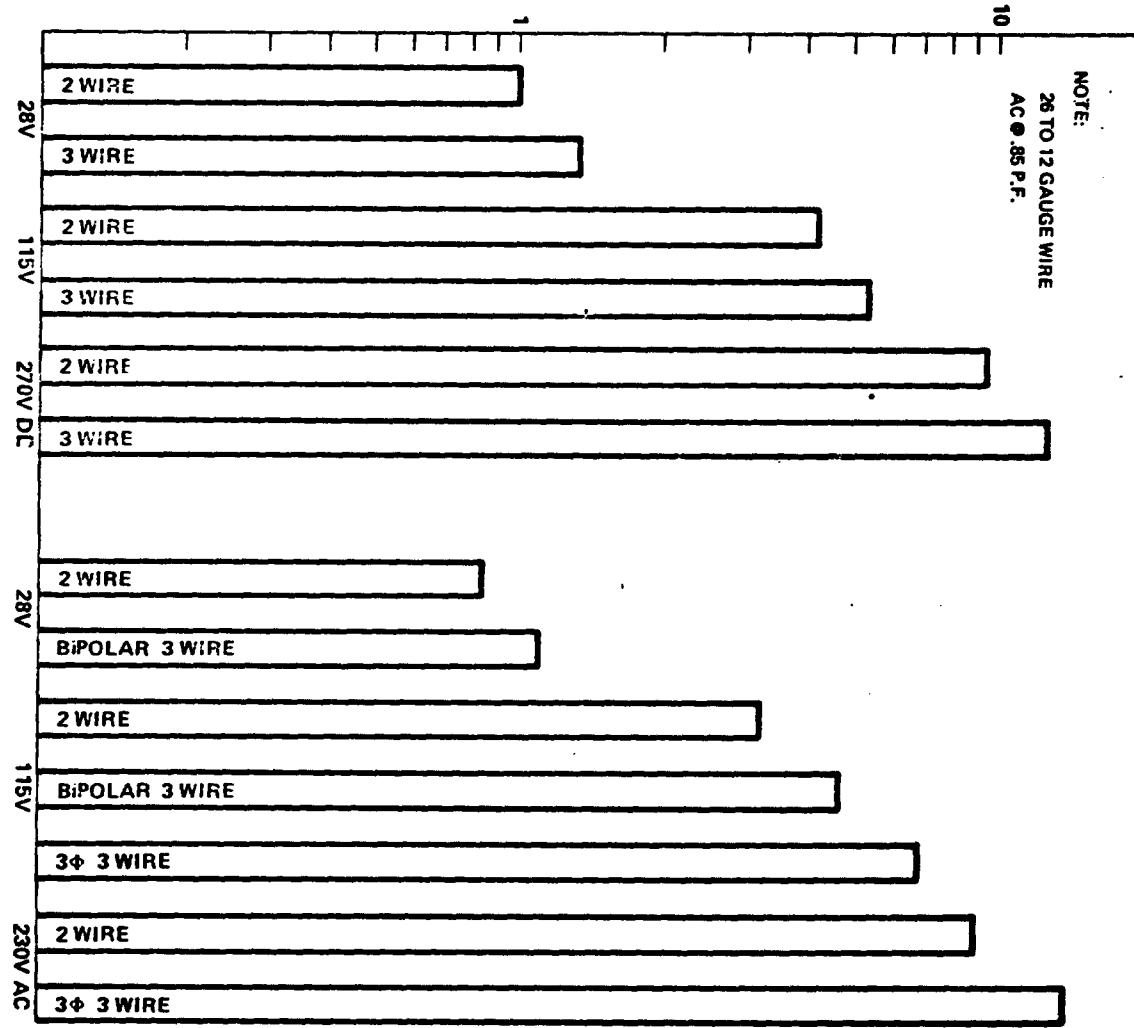

Figure 3-7.

4.0 SAFETY ANALYSIS

4.1 Hazards to Personnel

Shock Sensation

Shock sensation occurs at levels substantially below those required to endanger life from shock. This is particularly of concern in the use of solid-state switching due to the leakage at or above the sensation threshold.

This leakage increases with the use of higher voltage. People are frightened by shock sensation even when the muscular response is entirely voluntary. Secondary injury may result from violent withdrawal. For trouble shooting and servicing, utilization equipment should be provided with positive electrical isolation. At higher voltages this is harder to provide using RPC's as leakage can be felt from some pass elements when off. Additional investigation is warranted to integrate hardware and operational requirements to accomplish what the open mechanical switch or contactor has historically done in servicing of systems. In some industrial plants, the safety department insists on a positive visual break in the power circuits to be serviced. Built-in test, multiplexed controls and monitoring can provide reduced risk from inadvertent out-of-configuration occurrences after servicing and testing.

Muscular ability to withdraw from shock sensation contributes to reducing shock induced fatalities. Injuries can still occur due to fast or uncontrolled response in withdrawal. Muscular control can be maintained with higher values of current with dc. The threshold of sensation is one milliamperere.

Fatal Shock

Most fatal shock exposure would occur as a hazard related to 120 or 300 volt spacecraft during the manufacture and testing of the system prior to launch rather than in the spacecraft by the crew. Fatal shock results from fibrillation of the heart muscle from current that is impressed on it or from the loss of breathing. They are both time and magnitude related. There are large

differences in the skin resistance between individuals and the sexes. Women may lose muscular control and initiate fatal fibrillation with currents as low as 6 ma; men have a threshold of 9 ma. Thresholds are higher for dc than 60 Hz ac. A current of 18 ma may stop breathing, and with 50 ma breathing may stop in 3.5 seconds. (9)

It is theoretically possible to build a high degree of fatal shock resistance into systems by use of recognized designs and practices:

1. Most exposure occurs between line and ground and not line-to-line as line-to-line requires two simultaneous contacts by portions of the body that span the region of the heart. Extra insulation and double insulation reduces system failure rates and consequent incidence of bodily contact.
2. Ground fault detectors and isolators could be sensitive and fast enough to trip a circuit before fibrillation of the heart occurs or breathing is interfered with.
3. Require the use of mating connectors and high quality break-out boxes for all test access to wiring and require the power to be off for all configurations changes that include break-out box installation or removal.
4. Require use of recessed sockets for power supply side of connectors or provide control circuits in the power connectors that inhibit power from being turned-on until control pins are engaged.

4.2 Relative Safety

The singular ability to voluntarily direct the muscular response does not by itself make dc systems safer than ac systems. The method of grounding the system, the speed of fault switching, the sensitivity of fault detection, insulation level, location of the fault on the system, and inherent characteristics of dc on the system are factors to be considered for relative safety. A small 300 volt system can be safer than a large identically insulated 120 volt system.

Computer controls, built-in test and crew displays enter into power distribution system safety. Short circuit clearing time can be very short. Split second events in proper sequence enhance that system safety. Load shedding and power management are logical tasks for automatic controls. Higher power at higher voltages will require faster protection response rates to prevent exponential increases in fault induced damage.

4.3 Corona and Consequences of Electrical Breakdown

Corona

Corona and electrical breakdown are the greatest hazards to safety for space application of power distribution systems. Corona progressively degrades insulation exposed to this ionization. Given sufficient time electrical breakdown will occur. There is little difference between sources and distribution equipment in terms of voltage level that is safe, as the dynamic variables in the use of an electrical system can result in higher voltage at the loads than at the sources. Transients are more often introduced in the load and distribution circuits and it is usually the peak voltage that initiates breakdown not the steady state. The use of 120 or 300 volts is practical for space systems of 10, 50, and 100 kW with application of designs and techniques that are well known. These aren't simple however. Paul and Burrowbridge⁽²⁾ summarized the phenomena and the design techniques for controlling corona with cautions for vacuum and gas environments. It is the transitions of altitude/pressure that adds the greatest complexity.

Depending on the materials, temperature, pressure and time; some level of corona may be tolerated in space designs. Void free potting is next to impossible to insure. Geometry and accumulated charge vary the electrical field stress. Townsend and glow discharge do not immediately result in a spark or arc discharge. Solids emit ions and electrons due to thermionic emission, electron bombardment, photoelectronic emission and field emissions.

Very high strength fields can occur as two parts of a mechanical switch approach each other in closing. This is in addition to the breakdown that is familiar from the spark that occurs when opening a circuit.

Voids and discontinuities in insulation systems create changes in the electrical stress field within the insulation inducing corona which is ionization in the insulation void. Dielectrics used between electrodes can be overstressed by the simple insertion of material of higher dielectric strength in the electrical field in series with the lower dielectric strength material. Treeing can occur at stress levels below the corona threshold.

Corona Onset

The onset voltage of corona is determined by the transient voltage envelope not the steady-state voltage. Thus it can be appreciated that design margins are easily set empirically but are extremely difficult to implement on large distribution systems that have changing load conditions, temperature, pressures and resonant electrical characteristics. Switching rates can be the same at either 120 or 300 volts and greatly influence transients.

Significant dc Characteristics

Dc has a significant characteristic related to corona, discharge and voltage breakdown, i.e., accumulation of space charge in the vicinity of the electrode. The electrical stress field redistributes itself reducing the unit stress in the vicinity of the electrode while increasing it in the balance of the stressed field. All of the electrons or ions entering the field are acted upon by the voltage stress field and result in accumulated charge that could leak to the other electrode depending on the insulation quality and in doing so could contribute to thermal runaway in that insulation. The accumulated charge can result in discharge and arc-over. This has been observed in high altitude spacecraft when occulted from the sun when the normal photon energy that dissipates electron charge buildup is not available to add energy and mobility to the accumulated electrons. Voltages in the 10's of thousands have been verified and resulted in spark discharges. Charge neutralization design provisions affect the source and distribution systems as well as the spacecraft. Use of bonding and avoidance of electrical discontinuities in structure accommodate the phenomena for structures but not conductors (electrodes) as they must be insulated. The use of high voltage usually requires higher insulation thickness which increases the breakdown voltage threshold.

Zero Gravity and Needle Points

Needle points in gas or partial vacuum in electrical fields can ionize gas that in a gravity field would not necessarily be hazardous. At one G, thermal effects normal to power system conductors under load would thermally induce circulation of the gas and act as a deionization mechanization that doesn't occur at zero G. Therefore, the ionization can remain as a space charge around the vicinity of the needle point. If it grows to a sufficient length it can cause arc over. This can take place in sealed or unsealed devices as well as within discontinuities in insulation of normal distribution devices and bus hardware. It may be imagined how a chip, sliver or other metallic projection could inadvertently be present in insulation or on a conductor forming a sharp electrical stress field.

4.4 Relationship of Protective Devices to Safety

Switching Device Deficiency

HVDC is difficult to switch to off and this can't always be accomplished with devices normally provided for the task. This includes relays, contactors, circuit breakers, fuses, toggle switches and dead face connectors.

Switching DC

DC requires commutation devices with capability above that required by the transient induced by the load that is being switched (use of series multiple metal-to-metal contacts was discussed in Reference 1). The commutating energy required is a function of the combined sources operating in parallel and the contribution of all loads concurrently operating on the system. It cannot be tailored just to the characteristic of the load. The necessity to satisfactorily commutate faults off is the Achilles tendon of dc systems. The same fault that requires safe switching can drain the stored energy of the commutation capacitor and or inductor before the commutation takes place resulting in an uncleared fault. Refer to the discussion on protective devices in Section 5.

4.5 Experience with DC Systems of 100 Volts or Over

Most system experience is with systems that use switches, circuit breakers, relays and contactors that employ air-breathing, arc horns, magnetic blow-out coils and chutes. In space, sealed relays and switches have been used without critical evaluation of the zero G rupture capability. Apollo developed "nearly sealed" circuit breakers for use on 28 volts dc.

4.6 Institutional Aspects of Safety Related to Use of 120 or 300 Volts DC

4.6.1 NEC, NFPA, ANSI-C1

These codes establish safe residential, commercial and industrial wiring practice. They don't apply to spacecraft. Their main emphasis is prevention of fires and reduction of fatal shock hazards. The National Electric Code (NEC) sponsored by the National Fire Protective Association (NFPA) is merely advisory. Other laws such as OSHA, state and local laws invoke NEC as a requirement. Electrical inspection authority supersedes the code. American National Standards Institute (ANSI) Standards Committee C1 is the procedural organization that acts as the sponsor of the NEC.

Extract of DC Safety Related NEC Provisions

The NEC defines the threshold for Class 2 or 3 circuits that have inherently limited power sources or are limited from larger power sources by overcurrent protection as 30 volts dc continuous or 150 volt amperes where the highest voltage is 150 volts. The code restricts use of screw type lampholders to 300 volts. For circuits frequently in contact with the bodies of persons or exposed current carrying elements, the limit is 8 volts or must be moisture resistant (NEC 725-31, 517-64).

For hospitals and special occupancies, when ground fault protection is applied to the normal electrical service, one additional level or step of ground fault protection downstream (towards loads) shall be provided. It shall have a 6-cycle band below the band on the main for 100 percent selective trip. This is to prevent main trip operation except for feeder backup (NEC 517-41).

Plug fuses are prohibited above 115 volts, cartridge fuses are classified into three voltage sizes, i.e., 250, 300 and 600 volts (NEC 240-61).

Application of GFP or isolation to a dc system using a dc service entrance would not be possible due to one interpretation of the code. Two wire and three wire systems are required to be grounded but not at individual services or at any internal point on the premises (NEC 250-3, 250-22).

4.6.2 OSHA

The requirements of Occupational Health and Safety Act (OSHA) basically invoke the NEC, but also give all workers a complaint review procedure for matters affecting either health or safety. It applies to military or contractor personnel.

4.6.3 AF, SAMSO, Safety Specifications

The main thrust of these specifications is to place the authority and responsibility for safety and safety procedures. The definition and conditions of the specification do not control spacecraft wiring practices nor restrain the use of 120 or 300 volts dc. Interpretation is by the cognizant authority. The method of identifying who that authority is may only be clear on military bases. When in a manufacturer's or contractor's site with or without military personnel involved the cognizant authority is contractual without definition down to the operational level. There is no requirement to document the determination of the cognizant authority in interpreting AFSC DH series specifications. (AFSC H6 is the safety specification and AFSC H4 is the

electromagnetic compatibility specification). The AF makes the specification contractual, but accepts the contractors definition of qualified personnel and safety procedures. There are no identified specification barriers to spacecraft application of 120 or 300 volts dc. SAMSO has the responsibility for safety on the STS for all DOD and AF payloads. (Reference SAMSO Regulation System Safety Certification Procedures and Technical Requirements for DOD Space Transportation System Payloads, dated 28 Jan '77). To implement this they invoke the responsibility on the individual Payload supplier or contractor with the requirement that all related data and documents submitted to NASA be approved by SAMSO SPO prior to transmittal. All NASA/AF safety related specifications are considered to be contractually applicable. The contractor develops the safety plan and decides which is by test and which is by analysis and what acceptable design and procedures would be required.

There are electrical design goals and edicts to preclude any hazard to personnel by design and procedure wherein it requires that three procedural errors would be required before it could result in a catastrophic condition. There is no mention of explosion hazard control measures required in the Orbiter bay electrical provisions due to the potential of H₂ leakage.

Safe turnoff of payloads and remote monitoring of Payload safety critical subsystems are required of free flyers, but there is no requirement for redundant control and monitoring capability other than safe/arm which may be series redundant. There is no specified limitation that would preclude the use of 120 or 300 volts dc to spacecraft at any kilowatt rating.

4.6.4 NASA ICD 19001 Electrical Safety

This interface control document describes the Orbiter interfaces, EMI control requirements, grounding, bonding, caution, and warning interfaces to payloads. Its emphasis is on the capability of the Orbiter and the restrictions for power and thermal level on the payloads. There is no visible capability to support manned payloads except in the pressurized normally manned areas. Redundancy provided is for basic Shuttle functions. There is a requirement to protect the Orbiter and be able to secure or turnoff the payloads electrically by the Shuttle or Payload Operator. It hasn't been anticipated that redundant keep-alive power may be required to keep payloads safe. If this were a requirement, they would have to be supported by redundant cooling and controls as well as monitoring. Manned payloads will require assured electrical support, not just fail-safe provisions.

The short circuit capability to payload main bus protection devices is not defined. The fuel cell motor operated contactors are inadequately specified for fault capability and they are the only backup to the distribution protection devices for all loads. All devices used for protection off the main Orbiter busses should be qualified to the worst case fault potential on that bus.

Grounding is critical to electrical safety, but the grounding requirements of the ICD are subject to contradictory interpretation. Payloads are restricted to use of Orbiter structure return if in the cargo bay, yet the dedicated fuel cell is designed to provide ground isolation capability.

Use of 120 or 300 volts in Orbiter payloads is not restricted in the ICD.

5.0 TEST FACILITY MODIFICATIONS

The changes to the Power Distribution System Simulator (PDSS) for use at 300 volts as well as 120 volts are not extensive. The two Christie power supplies cannot themselves deliver the 300 volts required from the source for a regulated bus voltage of 300 volts. One additional power supply is required to deliver the desired voltage. Voltage regulation and the resultant load sharing may be divided equally between the units, or two units could be block loaded with the third used to regulate the bus. The design of the voltage divider used for the bus voltage sense determines the method to be used. A three segment voltage divider would permit the units to share load proportionately. These power supplies are isolated from ground internally and may be grounded on either terminal.

The Christie Corporation engineering recommended a careful review of any units used for terminal voltages over 300 volts. There is no problem up to 300 volts if the voltage and current sense leads are correctly interconnected for series or parallel operation. Before any procurement is initiated to supplement the two power supplies units now at MSFC, Christie engineering evaluation is recommended for the precautions and circuit provisions.

The distribution bus and load contactors are adequate for 600 volt operation at sea level and are arranged for any combination of eight circuits. The load banks are individual resistor grids and can be connected in any combination from eight in parallel to eight in series. Other load combinations are feasible with inductors and capacitors used in conjunction with the resistors to simulate characteristics of loads that are more dynamic.

Control Circuit Changes - There are several minor changes in control circuitry recommended to accommodate 300 volts:

Resistor R_1 in the status monitor and R6 in the voltage transducer should be changed or a potentiometer installed for selective use at either voltage.

Two circuit changes are recommended in the PDSS related to the power supplies. Panic buttons should be wired into the power input ac contactor to trip the power in the case of any significant damage occurs to items under test or to the PDSS.

Three Wire Power Distribution

The facility required to evaluate 3 wire distribution systems would be significantly different in that the number of sources would have to double as would the number of loads and load contactors. The least change would be to double the kilowatt capacity by adding a second PDSS in a mirror image. The present PDSS cannot have the negative bus float or be elevated above ground potential. To do so would require a redesign of the control circuits to permit 300 volt operation (two 150 sources additive) but with the center wire grounded.

Zero Gravity Testing

TRW does not have a firm recommendation for the best method of testing switching devices such as relays and contactors for zero gravity qualification but the PDSS could be used for control tests if an environmental chamber were procured for component testing in conjunction with the PDSS. Identical pallet loads of components could be tested first in the PDSS and then in the Orbiter payload testing. The items under test could be returned for evaluation and comparison with the controls run at one G and at simulated Orbiter pressure altitude environments.

Fault and Rupture Testing

For power system testing, the source should be able to match the dynamic as well as the static electrical characteristics of the in-flight envelope of systems that might be encountered by the component being evaluated in test. This may be too difficult to accomplish to be practical as even the variation possible from solar arrays is extremely broad. It should be recognized that even batteries have a different dynamic response one from another and this affects the validity of the test results for component testing. All inductive, capacitive, and dynamic loads such as motors and actuators inter-react with the source and components under test. It is essential that attempts be made to evaluate and simulate these affects as they relate to projected space application. Analytical methods have been employed with success in ac power systems but there is a large amount of data and guidance for evaluating the effect of these on different voltage and size systems. As dc systems become larger, data will have to be gathered to factor in the contribution of each stored energy device's contribution to system interaction. This is true especially as it relates to life testing and fault or rupture capacity evaluations.

To prevent the application of power of the wrong polarity, a circuit as shown in Figure 5-1 is recommended. The contactor and the back biased diode should be capable of the carrying the combined fault short circuit of the three Christie chargers in parallel or series for a period of time sufficient to trip the units including the filter discharge time constant. The contactor removes the diode if the polarity is correct so that normal bus characteristics are obtained for normal operation. Based on the contactor coil selected, provision may be required to switch a resistor in or out of the contactor coil circuit to accommodate both 120 or 300 volts.

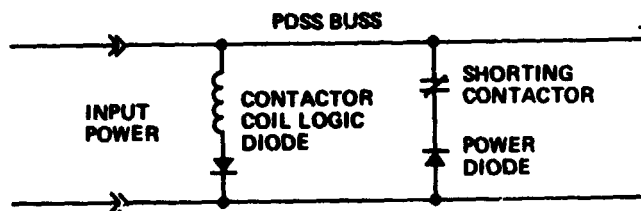
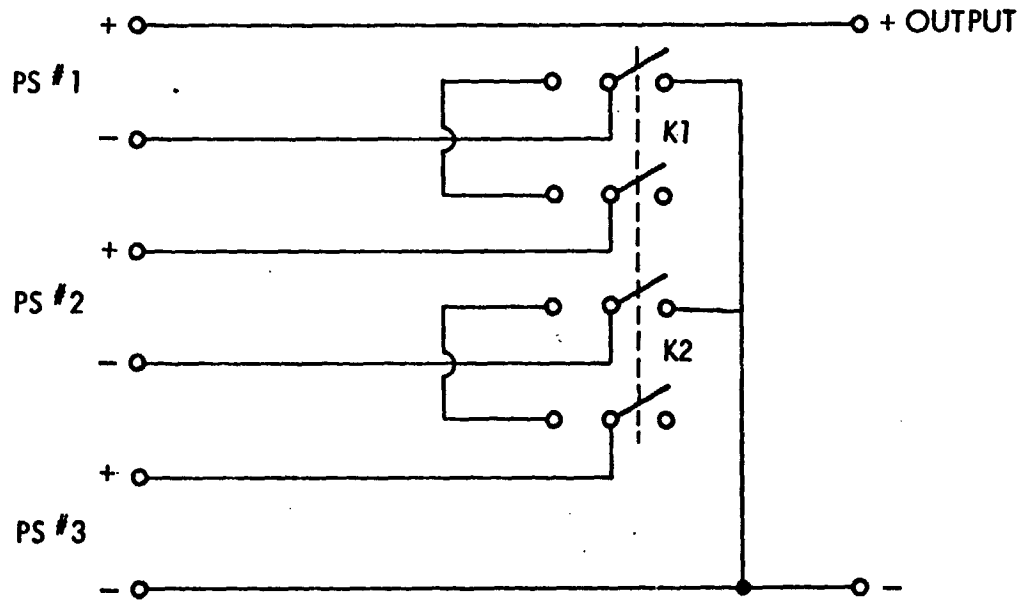
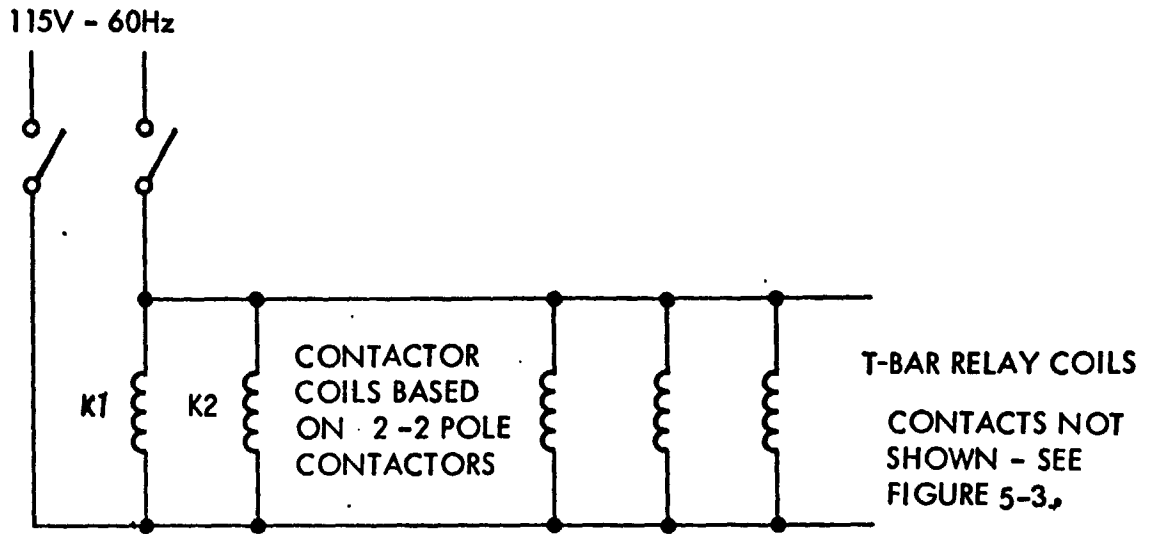

Figure 5-1. Reverse Polarity Circuit for Power Distribution Simulator

Figure 5-2 shows a suggested arrangement of control for three power supplies for parallel or series operation at 300 or 120 volts. The T bar relays could be located near the contacts they serve. By use of 115V 60 Hz power, standard contactor or contactors may be used and controlled by a panel mounted toggle switch. Figure 5-3 shows the suggested manner of connecting J-bar relays to the status monitor and voltage transducer circuits.



3 POWER SUPPLIES (PS) SERIES OR PARRALLEL
 40.5 Kw AT 300 VOLTS
 48.6 Kw AT 120 VOLTS

Figure 5-2.

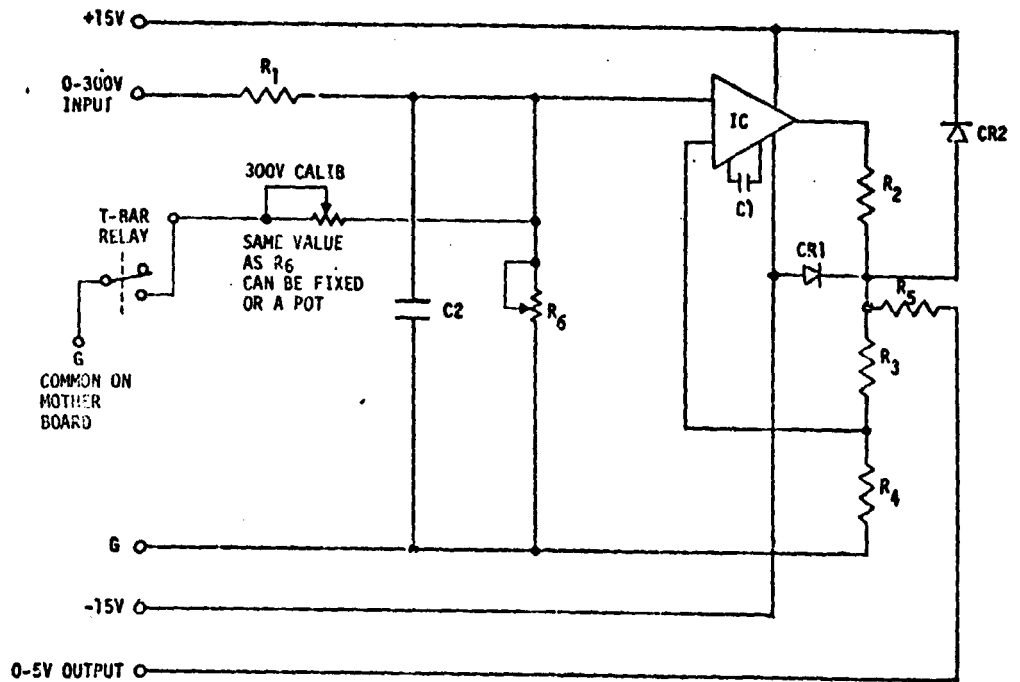

VOLTAGE TRANSDUCER (VT)

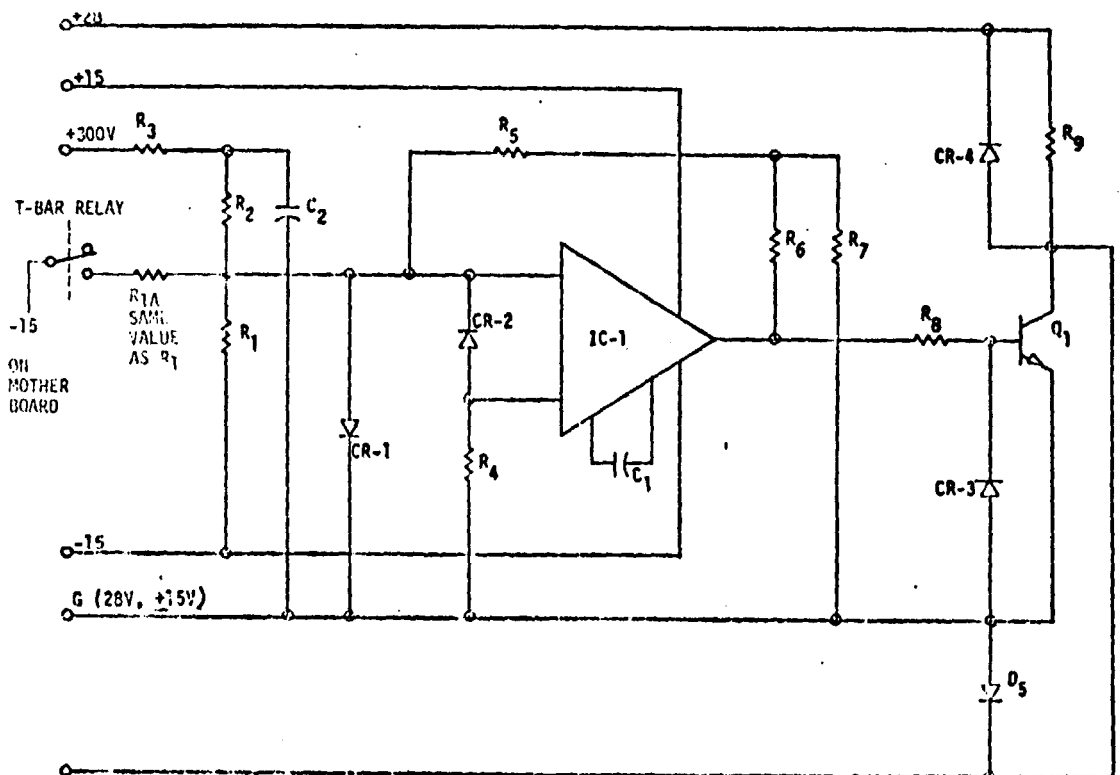

Figure 5-3.

6.0 TECHNOLOGY ASSESSMENT

6.1 Sources

Aspects of sources related to 120 or 300 volts dc distribution technology are discussed below.

Regulation

Voltage regulation (response to change) determines power quality. Fast hard bi-directional regulation is the goal of regulating provisions of sources. This affects the short circuit and fault isolation coordination potential of all of the protection equipment to all loads (see Section 6.2).

Source Impedance

Source internal impedance is dynamic and low internal impedance does not provide the highest stress on circuit breakers, contactors or fuses in the event of a fault. Highest stress occurs in the protection device at the highest rate of power delivery near the interval of time just before successful arc extinction.

Current Limiting

Current limiting of sources below 2 pu increases fault clearing time for protection hardware and adds to the I^2T and thermal effects at the fault. The method of assuring short circuit fault containment for distribution systems has been to require more capability from the source under fault than under steady state conditions. Acceptable limits have been 2 pu for torque and 3 pu for current as a minimum.

Paralleling - Load Sharing

Regulated power sources should be capable of being paralleled with identical or different sources with provisions for load sharing for a proportional share or differential share of the load as desired. Greater operating flexibility could be had if the fuel cell with the greatest aging could be operated at full load in parallel with a new one at light or no load. Even identical units can introduce problems for control for parallel operation depending on the point and method of voltage regulation. The goal for space sources

should be to provide capability for operating in parallel with like or unlike units to near or remote busses with good quality voltage at the utilization equipment.

6.1.1 Solar Arrays

There are no technological barriers for application of solar arrays in 120 or 300 volt distribution systems if operated to deliver regulated power to the main bus in parallel with regulated batteries or fuel cells. There are design alternatives for 50 and 100 kW systems that require optimization for near-term and long-term application. Included is the problem of shadowing of solar arrays as related to voltage levels selected. Shadows can occur due to appendages, approaching vehicles, inadvertent maneuvers of the spacecraft or nearby servicing vehicle that would cause back bias of the solar array and cell failures. It is possible to keep the solar array panels disconnected during Orbiter transportation until staging from IUS or other booster provided the support vehicle had the necessary power to support the vehicle for all maneuvers until solar array activation. However, the likelihood of preventing shadow on large arrays for all worst case temperatures, loading and voltage conditions could be impractical and no assurance can be had until the full design and use of all appendages, their articulation and vehicle orientation envelope are considered along with similar consideration of any sunline obstructing vehicles or structures. The higher the voltage selected for solar arrays, the more essential it is that shadow induced back biasing of cells be considered. Jett and Miller (8) have pointed out that shadowing and cell failure in parallel cells within the string have similar effects on the temperature of the unshadowed remaining cells. A special study appears justified on comparative silicon cells applicable to 1985 earth orbiting spacecraft and viable gallium arsenide alternatives in terms of costs and back bias hazards due to potential shadowing failures.

6.1.2 Fuel Cells

Fuel cells are well suited to use in larger systems at higher voltages. They offer the capability for containing short circuits on the bus in a back-up mode by valving off reactants.

6.1.3 Batteries

Batteries may be used either at similar or different voltages than the main distribution at 120 or 300 volts dc. Their use requires both charge and discharge regulators that determine their characteristics to the distribution system. None are currently available in the sizes that would be best for larger systems. They should be designed and tested with the charge and discharge control equipment for their intended application. There are no technical barriers to development and application of higher-voltage, higher-power batteries.

6.1.4 Rectified Alternators

Alternators used as dc sources have no technological barriers to use at any kW or voltage level for dc. Greater emphasis is warranted on system efficiency in that it represents a cost per kW of capability and even one point of efficiency could have an equal or larger proportional impact on the total power system cost. Dc brushless alternators are the most efficient in terms of the rotating and magnetic portions of the generator, but can lose out to a conventional wound machine when the regulating electronics are included (see discussion in 2).

6.2 Switching Components

Switches, contactors, circuit breakers, limit switches, and toggle switches are not available to mechanize 120 or 300 volt systems of 50 or 100 kilowatt rating. Promotion of dc at larger power ratings and voltages should recognize the extent of the limitations switching devices have on protection

and distribution. As transistors are extended in the voltage and current ratings and capability, larger systems may be built. At the present time, power capability of transistors has not gone up substantially with voltage in applying them for use as circuit breakers. When system application requirements are reviewed, it will be found that equipment being used at present is marginal and exploration of higher power and higher voltages with today's devices is not at all promising.

Bus Protective Devices--Contactors as Circuit Breakers

Pressure vented, gas filled, and air cooled contactors are not considered as suitable for projection to application in large manned and unmanned space systems. These devices are the most critical element of a power system when used to perform the main bus switching function and provide backup assurance that any smaller bus protective device such as fuse, circuit breaker, RPC, SSCB failure can be contained. There is a requirement in manned systems to treat a bus fault as a credible failure and to design the systems such that a main bus fault does not cause loss of crew or mission completion. In actual practice although the bus doesn't fail, it has to be switched off to clear the fault that was the failure of a load protective device to do its job (fuse, circuit breaker, RPC, SSCB). When systems are larger in capacity, switching bus protection hardware becomes more stressed and nearer to the threshold of failure even when correctly applied.

To summarize, the bus fault protection equipment should be capable of sensing and isolating and uncleared fault downstream of the bus. The number of devices used for wire protection is large and they should be used with the view that they are also to protect the bus to which they are attached. As an example, the 747 has over 800 circuit breakers, the B-1 has 1400, and a 12-man space station was estimated to require up to 2000.

Sealed Switches

Sealed gas filled mechanical switches do not perform the same in zero G environment as they do at one G. The gas behavior in the vicinity of the arc in zero G is substantially different. In a one G environment the energy of the arc adds to the turbulence of the gas in the arc and due to effects of gravity, the direction of the gas flow is predictable and the path is used by design to help cool and extinguish the arc of the parting contacts. The pressure of the gas is essential to prevent sharp induced voltage transients and to reduce damage to the contacts. In dc, the work dissipated in the arc is the sum of that required for the load and that required from the source. See Appendix A-1 on Arc Phenomena.

Vented Switches

Vented switches such as MIL spec aircraft circuit breakers require the presence of the gas and gravity to successfully rupture currents that they are specified to rupture in their qualification testing. In other spacecraft environments for pressure and temperature, including those tested for, the circuit breaker does not have the same capability due to the absence of gravity. The gas heated by the arc will go in any direction at zero G. The cooling and ion transporting function of air (gas) external to the circuit breaker is essential to its rupture rating capacity. Large exchanges of gas occur during a circuit breaker fault rupturing operation of the air internal to the CB, the air external to the device, and the gas between the contacts. This cooling and deionization of the arc requires the larger volume (internal and external) to accomplish its specified rating for rupture. Zero G destroys the natural circulation created by the blast or arc heat reducing the potential of the device to rupture. The same relationships hold for pressure vented switches.

Fuses

Fuses are normally accepted and permitted to fail through their case provided they don't ignite combustible material placed next to them under test conditions for safety. Few fuses are truly hermetically sealed as the ability to expel gas is the safety valve to their arc extinction capability (other than silver-sand types). Fuses that are hermetically sealed do not have high rupture capability.

Magnetic Arc Blowing

Magnetic blowing of arcs in contactors, relays and circuit breakers may be employed. The arcs are extended by the magnetic fields created by series coils or by induced eddy currents or magnetic arc chutes. These are very effective with a fault current of sufficient magnitude. However, stable arcs much lower than the maximum fault current of the system do occur. The protection devices relying on this for arc extinction cannot be expected to rupture small currents that sustain an arc. The fault in series with the protective device can provide series impedance that limits the current and prevents magnetic blowout of the arc. Refer to Rudenberg⁽²⁾ discussion on interruption of dc.

Zero Gravity - Rupture Capacity - Cycle Life - Gas Filled Switches

Relays, contactors, fuses and circuit breakers are of unknown capability for use in zero G in respect to rupture capacity. There is also a concern for the cycle life at normal loads from the same effect. This is not as urgent a concern as rupture margin because of the probable consequences of a failure. The failure could only be indirectly related to a distribution system failure. The contacts could weld closed or fail to open; neither of which should result in any catastrophic consequences.

Rupture capability is the assurance of safe failure isolation versus potential failure propagation and clearly merits critical review for safety. Useful operating cycle life of gas filled switches operating in zero G is an unknown and may be significantly less than at one G.

Conductive Cooling

Space rated distribution hardware should be capable of utilization in hard vacuum or pressurized locations and tolerate pressure cycling. There is a need for cold plate cooled design for contactors, relays, fuses (fuse holders) and circuit breakers. RPC's have been designed for this, but have capacity limitations when contemplated for higher power. Hybrid contactors used as circuit breakers can be built for specific HVDC switching applications that would permit construction of 50 or 100 kW at either 120 or 300 volts dc. The need for conductive cooling applies equally to ac or dc devices. How one gets the heat out of critical parts of protective devices affects the total performance of the device.

Commutation of DC

Switching of dc above the capability of transistors requires use of commutation circuits and devices to turn the power off. This applies to contactors, fuses, relays, switches, and SCR's. This is the most critical task of a protective device. Application of bus and load protection devices in quantity that employ commutation hardware complicates both operation and protection of the system. Fault clearing time is an envelope that includes the time to store commutating energy, the time to detect the fault and the switch clearing or operating time.

Technology exists for designing commutation for switching any discrete load from any pre-determined source capability. The effects on a system with a multiplicity of such devices has not been correctly anticipated. The energy that has to be stored in each switch has to be equal to that of the worst-case system. The accumulation of all the stored energy drastically alters the system performance. All of the devices that are to be capable of turning off must be charged up on the initial power turn on. The transient inrush if not controlled would be some large multiple of normal steady state load. If limited for current delivery rate, the time to attain the turn off threshold capability is extended. If loads are staggered to lessen their impact on the bus, long system turn-on times would be required. The effect of a multiplicity of energy storage devices would be to add to the fault current that has to be handled by each commutated switch. They add to the commutation need of each as additional sources in parallel would.

In a branch circuit that could receive a fault that would require safe commutation, this fault would drain the energy out of the discrete switches commutating energy storage components defeating the ability of the switch to successfully clear the fault.

The performance of even a simple system under dynamic switching conditions becomes a major analysis task to account for the inductive and capacitive effects as a function of switching transients.

Effect of Higher Voltage on Moving Contact Switches

The current rating of the contacts has to be less when used at higher voltages. The derating factor is exponential and of greater power than $n = 2$. A 28-volt dc contact would have to have its current rating decreased for use at 56 volts by $(\frac{28}{56})^n$ where $n > 2$ for the same life. Characteristics that would be improved by higher voltage and decreased current are contact bounce induced transients, steady-state contact loss as a percent of the power switched, and ability to overcome dry circuit or contact contamination. Contact clearance required for relays, switches and circuit breakers has evolved by usage and is not standard for all devices due to materials, gas, gas pressure, contact bounce, contact travel distance, rate of travel, operator force and factors that include temperature and gravity induced thermal effects.

Hermetic sealed contactors are nearly non-existent for higher voltages at high currents with dc. Most use nitrogen gas with pressure relief valves to permit normal operation, but if a fault occurs the valve can vent substantially degrading the contactor for reuse since there is no positive indication of pressure relief action. This is a serious shortcoming to prolonged repetitive use.

6.3 Cables

There are no technological barriers to the use of 120 or 300 volts dc related to cables. Shielding and twisting of wire pairs can be more economically accomplished with smaller gage wires permitted by the use of higher voltages.

6.4 Connectors

Connectors for use on spacecraft at 120 or 300 volts will require larger pin spacing than provided for in 28-volt systems. Environmental sealed connectors that are capable of sealing through one atmosphere or more of pressure differential could be used in most locations to combat corona threshold effects possible at terminations used in the Orbiter bay. This would not make provision for mating and unmating while energized. Hazard exists for corona and breakdown if flyaway umbilicals were energized during separation. This assumes the connector was mated at one atmosphere pressure and is being demated in vacuum. Unless a method of venting the connector cavity were provided while a seal was maintained on the individual pins, a problem could be anticipated (2). Deadfacing connectors blown apart as on Apollo could simply move this problem to those connectors rather than the flyaway umbilical depending on their location, ambient pressure and temperature.

6.5 Controls and Supervision

Technology is rapidly changing for application to power distribution systems and their control. Power systems are integral to the total spacecraft system and vital to most other subsystems. Manned systems require greater redundancy and future vehicles will be more complex than Apollo, Shuttle or Skylab in terms of the automatic operation of power systems. Caution and warning and other crew displays will incorporate built-in test and operational status.

Early recognition of the interdependence of subsystems and the relation of a multiplexed control for power distribution can result in significant simplification. Future systems will be as complex as the AF B-1 in terms of computer/multiplex controls for the electrical power system, but the hardware can be grossly simplified over that used by combining driver logic and multiplexed discrete output logic.

It is possible to build a four terminal RPC that totally isolates control from power circuits, provides control stimuli and status over the same two control wires. By providing the computer command latch and memory function at the multiplex terminal rather than in the subsystem downstream of the RPC, the RPC can be operated at any voltage within its rating as a current not voltage limited device. This permits one size RPC to serve 28, 120 or 300 volt circuits from a single part number with one current rating.

With proper status monitoring of RPC's assurance can be had that all four pins or terminals are mated. This can be done with or without power on the power bus the RPC is connected to.

To operate redundant power distribution redundant control, display and cooling should be provided. To permit built-in test of computer and multiplexed logic on a real time basis, data busses and computers may have to be triply redundant.

The first requirement of adequate power systems control is adequate fault isolation protection. Damage possible from power system failure in a very short interval of time prevents use of system design requiring crew response for maintaining safety. Multiple sources and operating modes clearly indicates computer monitoring to establish matrix configuration for each mode. Provisions for verifying each RPC or other switches controlling loads would be required.

Ground Fault Detection and Isolation

Development is required to provide fatal shock resistant power systems for use of higher voltage and higher power levels. OSHA requires the use of ground fault detectors and isolators in certain critical exposures in non-spacecraft installations. Current sensing devices such as the current transformer, Hall effect device or even shunts may be used in the logic portion of a ground fault detector. No equipment has been identified that can be used to perform the isolation switching fast enough to permit the same relative confidence as given by industrial 60 Hz ground fault detectors and isolators.

Development of the protection equipment should precede the application of HVDC to larger power systems. Full scale, 100 percent simulation of sources, loads and protection devices as a system in normal and fault conditions should follow protection equipment development.

7.0 STUDY CONCLUSIONS

DC systems of higher power and voltage ratings can be built if adequate protection hardware and methods were available. However, there is little prospect of a basic invention that could provide adequate capacity for use in space for dc distribution irrespective of cost, weight or rational operational constraints. The transistor is growing in capability and its suitability for application must be watched as it essentially defines the usable voltage and power for dc power systems in space.

The problem of commutation for SCR's and contactors becomes nearly unmanageable as each load and each protective device adds to the collective commutation requirement. The absence of gravity thermal effects on switch, circuit breaker, relays and fuses should be evaluated.

Problems defined in this report in the projected application of 120 or 300 volts to 10, 50, and 100 kW systems can be overcome in an dc/ac system utilizing existing technology and hardware. RMS voltages up to 440 Vac at 400 Hz could be used in space systems with reasonable attention to corona and zero gravity effects in mechanical switches. Dc sources such as solar arrays, batteries and fuel cells can be used with modularity corresponding to the inverter capability used for each source. On array switching and fuel cell reactant control can be employed to provide backup protection to the dc to ac regulated inverters. Orbiter payloads could best be supplied with high power with regulated ac from Orbiter busses or independent busses.

APPENDIX A-1
DC ARC PHENOMENA

DC has a greater arc sustaining ability than ac of normal power frequencies at equivalent average current and effective voltage and as a result has a greater potential for damage. Depending on composition, temperature, and pressure of the atmosphere; ionization is created by the heat of the arc whose power is the product of the current and voltage in the arc. Turbulence created by the arc in the gas helps cool and extinguish the arc. The highest rate of arc power occurs at the least current that the voltage will sustain or initiate a restrike of the arc. This is the instant when stress on the contact is the greatest.

Blowing

Dc arcs often exhibit an instability in the time and condition near arc extinction that causes rapid interruption and restrike. Reignition may repeat many times even when the gap is increasing. The magnetic effect of the current interacting with magnetic blow-out coils or devices extend the arc. For strong magnetic fields, current is forced to decrease rapidly. This rapid change in current induces large voltages as the arc sputters. This sputtering or showering of the arc in the contactor or circuit breaker has a detrimental effect that causes over voltage and damage to the load insulation and components.

ORIGINAL PAGE
OF POOR QUALITY

Stable Arcs

For stable arcs at low current, high circuit resistance needs to be present with a high voltage. The relationships are shown in Figure A1-1 for arc length, circuit voltage and current⁽³⁾.

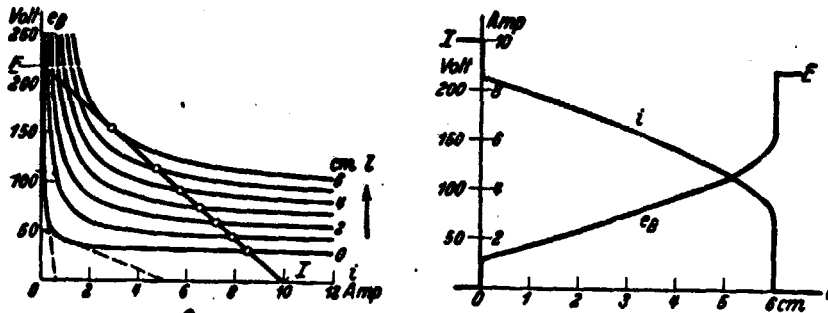

Figure A1-1

Current I is plotted at the stable arc intersection point for variation in arc voltage and electrode or contact spacing. From inspection the instantaneous current i is the least and the arc voltage e_B the longest just before extinction at 6 cm spacing.

Protective Control Complexity

In the early days of nuclear reactor controls for power systems, there were so many safety devices so sensitively set that reactors were always scrambling without being initiated by true faults or failures. As the industry matured, the application required less equipment and the protection equipment was upgraded in reliability so that false trips are nearly eliminated. Development of dc power distribution protective equipment for use in space should not follow the same pattern of development.

The failure to detect is not deemed that catastrophic (even though a failure might endanger or kill the crew). The historical pattern for spacecraft systems has been to rely on simplicity; not complicated switching and redundant safety devices. Protection of spacecraft systems has meant keep the wire between the circuit breaker and the utilization equipment from overheating to the point of insulation failure. Often backup protection to CB, relays or fuses was the knowledge that some wires could act like fuses. In industrial and utility installations, the option for simplicity is normally not open. The economics of the situation or the requirements of electrical code dictate the need for complexity and redundancy. Every main utility circuit breaker or switch is analyzed for its impact if it doesn't do its job either from its own failure or the sensing and control circuits that are used to operate it. Back-up protection is provided and carefully calibrated for performance. Given sufficient elapsed time, failures do occur in almost every critical component. Loop, ring bus and other main bus arrangements are used extensively. As spacecraft mature for longer stay times with men in them, greater use of redundancy and back-up provisions will be indicated rather than statistically relying on the inherent simplicity and limited exposure to the fault probability.

Apollo, Sky Lab, and Orbiter were not designed to this philosophy and the hours of risk exposure are magnitudes less than a 747 or B-1. Long-term stays in earth orbit (30 days to several months for the crew and years of active use for the equipment), require greater attention to the capability and use of the bus protection devices. This is normal for commercial, industrial and utility power systems, but has not been a major concern to unmanned spacecraft. Manned spacecraft have had a phenomenal safety record when the shortcomings of the protective equipment used is understood.

A general point of reference for design requirement of power distribution systems can be found in modern aircraft. Bus contactors and generator contactors are designed to be used as power switches under load. They are not designed for repeated rupture of maximum faults. They are qualified in two ways. One is as a power relay to MIL-C-6106 qualification requirements. Although generally accepted as sufficient verification, these so called rupture tests are not the truly worst-case events and are performed with dc current even when applied to ac systems. The other qualification method is to test in either the aircraft or a ground simulation of the flight power system. In this case they are operating on ac, but no effort is expended in exploring the envelope of potential fault characteristics. Again maximum current is equated with maximum fault rupture capacity. This is not correct.

Maximum power is delivered to the contactor when the impedance of the source and the feeder connecting it to the contactor are added together and are equal to the impedance (dynamic under fault conditions) of the protective switch and the actual fault in series with the switch and its feeder or wire impedance.

Loads Also Affect Protection Requirements

The filters applied in the input of most electronic equipment deliver or take current during transients and affect the protection equipment sizing and rupture requirements. There is a high order exponential relationship between voltage and the problem of interrupting faults in the

FIGURE A2-1

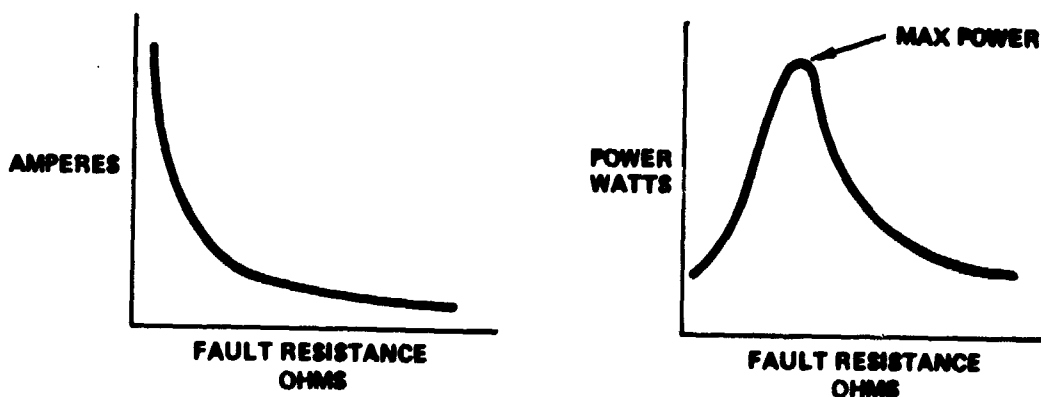

of both low and high resistance or impedance. 300 volts is more difficult to commutate than 120 volts. Equipment such as motors and actuators, solenoids and other magnetically coupled devices deliver energy back to the system on a fault transient. Commutation can be tailored to any known load characteristic. This isn't too practical for projected yet undesigned systems. Lack of protective device interchangeability for discrete systems would make the unit cost of protective equipment extraordinarily high.

Grounding of dc Sources

Good grounding and good protection are nearly synonymous. All of the candidate sources have potential for operating isolated from ground or solidly grounded. In isolated operation, provision would be required especially on alternators and fuel cells to provide static discharge paths to forestall insulation puncture when they weren't connected to the system loads. Flowing gas and rotating equipment are prone to static charge build-up.

Grounded systems provide a high likelihood of detecting inadvertent grounds depending on what the potential of the short above ground

Single point ground systems permit use of ground fault detection and fast acting protective switching. See discussion in Section 4 on safety.

Isolation for independent grounding from a common source using dc requires such hardware as transformer coupled dc to dc converters or inverters which if not required for other reasons are a penalty to the utilization system. Isolation can enhance the fault detection isolation capability as the wiring capacitance in the isolated circuit determines to a great extent the sensitivity of grounded fault protection. Increased capacitance decreases the sensitivity attainable.

A very important requirement of umbilicals between normally free flying vehicles is to maintain the single point ground even when power is transferred between vehicles. This requires switching of the control to one or the other vehicles if they are to share power from a common bus.

Paralleling of dc Sources

Load sharing from converters, inverters and generators equipped with compound field windings and controls can control load to controlled amounts proportional to their size or differentially as desired. Fuel cells, batteries and rectifiers cannot. Their internal impedance determines their load regulation characteristics and the percent of shared load with other devices. Line regulation for sources such as Orbiter fuel cells can become significant. A hundredth of an ohm is 4 volts at the 12 KW fuel cell rating.

Use of Experiment and Payload support fuel cells to power the Orbiter fuel cell busses in parallel or transferring power without load interruption would require the use of an output regulator to interface the units.

Current Limited Sources

Current limiting of source to levels less than 2 pu is counter productive to the solution of the circuit breaker and fuse coordination problem. The paralleling of current limited sources poses new and difficult problems for power distribution especially if cascaded or series protective device coordination is required. The logic response time of any source controlling protection equipment becomes much more time critical as the size of the source and the number of units in parallel is increased.

Prime Movers - BIPS/KIPS

The planned BIPS and KIPS system at 1.3 to 2 KW have a shortcoming that precludes good short circuit clearing ability. They are parasitically regulated for voltage with a turbine that is designed for constant speed and load. The effect of this is that the turbine sags in speed at the

time that a short circuit flows preventing minimization of the I^2T delivered to the fault. Stiffer sources have been traditionally used as the method of obtaining acceptable short circuit clearing times. Use of BIPS/KIPS design will require batteries, fuel cells or flywheel generators applied to the main lines in parallel with the turbine driven alternator for transients.

Alternators and Energy Storage

Because of the large ratio between peak power and average power that is anticipated on manned spacecraft, energy storage systems continually applied to the main bus will be required. Otherwise the prime power source would have to be sized to the E.O.L. peak load rather than the E.O.L. average load.

Fast Response to Load Change

There are potentially large differences in the subtransient reactance of the candidate machines for dc with large variations in filtering possible. This should be explored further to determine qualitative differences. It may be possible to use hard field forcing in both directions using less amplification than has been traditional in order to reduce the time constant of voltage response.

In the use of solid rotor permanent magnet types machines, use of higher frequencies is counter productive to reducing the subtransient and transient reactance of the machine.

Cable and Feeders of Main Power Sources to Main Busses

To accommodate the loss of a main power source or main bus, the kW capability of the main source feeders has to equal the peak power demand for 50 percent of the peak design capacity if a three main bus configuration were used, and must have a 33-1/3 percent design margin if four sources and four main busses were used as the configuration.

For analysis, the three bus, three source configuration has been assumed. See Figure 3-1, Simplified Conceptual Power Module One Line Schematic. An assumption is made that loads can be so connected or transferred after the occurrence of a fault to essentially balance the load on the remaining two main busses. This permits the least size source to main bus feeder. Provision has to be made for ampacity, voltage regulation and short circuit thermal rise allowance. Ampacity refers to the normal current rating of the conductors for the design worst-case ambient conductor grouping and conduit fill.

There is a requirement to optimize the feeder to the least weight, but the use of multiple parallel conductors that yields least weight, has a competing requirement that must be factored in. This is the thermal rise permitted on a single conductor of the feeder group due to a fault when the protective devices (circuit breakers or contactors) require time to permit fault sensing and tripping. If the clearing time is long, this becomes a major weight influencing design requirement as a single wire of a parallel set should handle the fault current without permanent damage or propagation of damage to other conductors.

Wiring - Sizing Parameters for Voltage Drop and Thermal Capacity

The demand on the source for ascending time increments can be likened to an inverted stepped pyramid as shown in Figure A2-2. The five second maximum demand rate is often used for voltage drop conductor sizing for steady-state loads. It is longer than the load response time of the regulator of the source and thus becomes an acceptable value for determining the voltage drop requirements of the distribution system. This determines the wire gage to be used for feeders and load distribution. The fifteen minute worst-case demand may be used to provide the thermal or ampacity rating required of the conductors and approximates the capability of the source end of life (EOL) design requirement. Conductors are, depending on the location and use, sized for three different characteristics; current carrying capacity for normal load, voltage drop limit for operation under non-fault conditions and additional thermal heat sink capacity to allow for short circuits to occur and be interrupted by the protective devices without permanent insulation damage of the wire that connects the source to the fault location. Figure A2-3 A2-3 diagrams the relation of the source, main busses, source to main bus feeders, distribution feeders, distribution busses and the wire to typical groupings of utilization equipment or loads. For simplicity, a uniform diversity factor is diagramed. Distribution busses are actually tailored in size to the group of loads nearest the bus and vary in size accordingly.

Pyramiding of Conductor Cross Section

In wiring, a pyramiding occurs in the effective cross section of the conductors that tapers from the source and its bus down to the load wires. The first top step of the pyramid has to be big enough to account for the worst-case source capability at BOL for short circuit and thermal rise provision. See Figure A2-4. Depending on the distances, the number of distribution busses provided, the location of the sense point of regulation and the voltage drop permitted this portion of the series circuit of source to loads may have to be increased over the minimum conductor required for thermal reasons. However, by use of fast response regulation of the source voltage to the main bus, the full permissible voltage drop allowance may be assigned to the distribution feeders and wire to the loads and the least size conductor

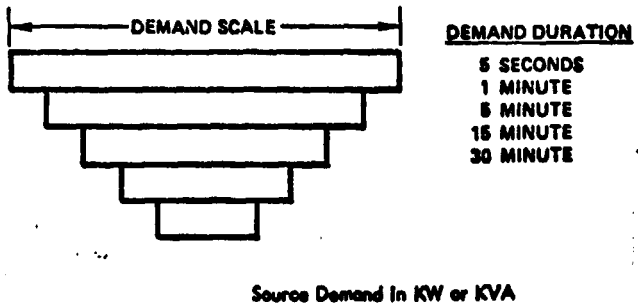

Figure A2-2

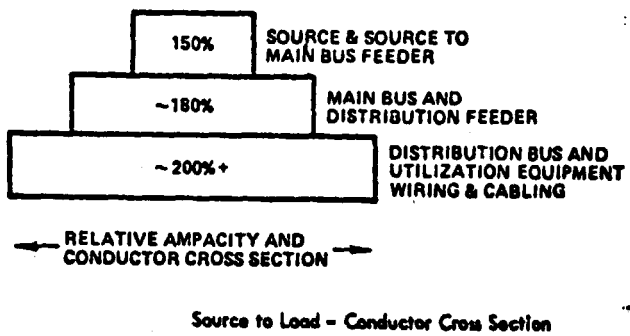
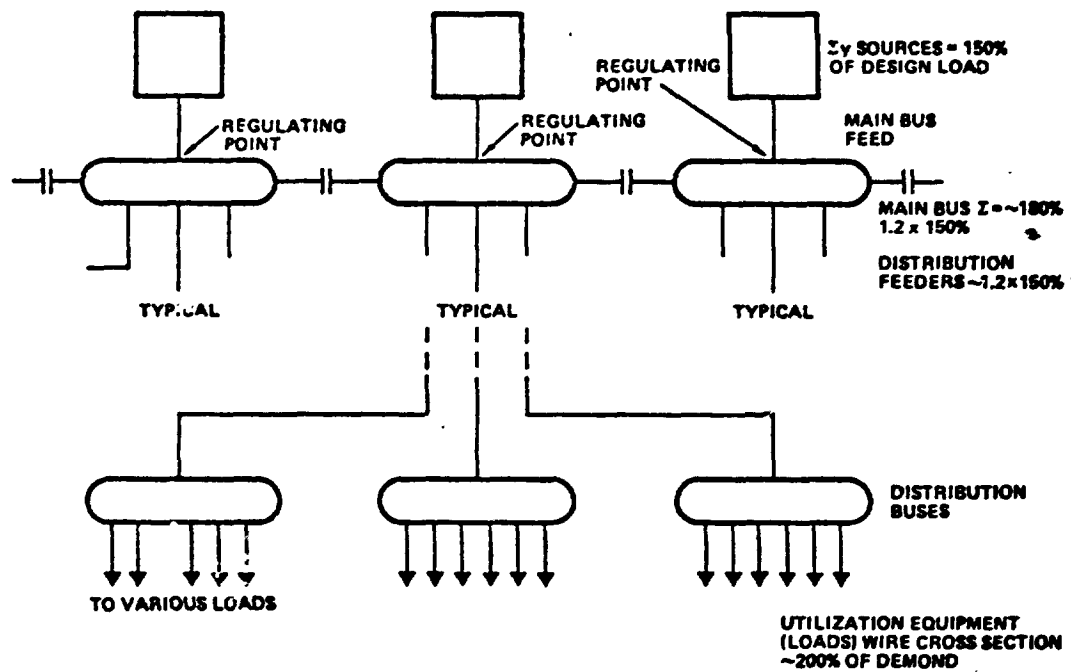

Figure A2-3

ORIGINAL PAGE
OF POOR QUALITY



Typical Source to Utilization Equipment Wiring Capacity

Figure A2-4

from source to main bus may be based on thermal requirements. The next step in the series pyramid conductor cross section capacity is the main to distribution bus feeder referred to as distribution feeder. These have to provide a larger diversity of peak to average load than the source bus which proportionately increases their cross section. A good portion of the allocated voltage drop may be used by distribution feeders if the last step provides for short lengths to loads. The last step has the greatest effective cross section due to diversity in loads and the losses for fuses, circuit breaker relays or RPC's used to switch them. Here is the largest penalty to total wire weight especially at low voltage which requires proportionately larger amperes for each load served and this affects both ampacity and voltage regulation adversely. The least size wire that would adequately serve the peak 15 minute demand of the load for ampacity is not adequate if any substantial wiring distances is required. In 28 volt systems, this is almost always the case. At 120 or 300 volts the distances that can occur on a vehicle such as an Orbiter are usually too short to cause use of any but the minimum wire required for the ampacity rating, or in the case of small wire, the least wire permitted for mechanical reasons. In the case of one large flight system, 26 gage wire adequately serves more than 50 percent of the total number of individual power circuits. With use of twisted and shielded pairs for mechanical reasons, even smaller gages could be used. Common cable assemblies can accomplish reductions without appreciable risk of mechanical failure.

Voltage Drop Plagues Low Voltage Distribution

Most wire (those from distribution busses to utilization equipment) on low voltage systems such as 28 volts have to be kept to sizes larger than the ampacity rating of the wire due to voltage drop requirements. In higher voltage systems most wires (distribution to utilization equipment) are neither voltage drop limited or ampacity limited. The smallest wire that is permitted for mechanical reasons has excess current and voltage regulation capability over that required for the majority of loads.

Wires 26 to 12 Gage

A table was prepared showing the length of a circuit (two wire) for the eight most common wires used on systems to show the allowable distance between a distribution bus and a load. The voltage drop allowance was based on MIL-STD-704 Category B loads; 2 volts for 28 Vdc, 4 volts for 115 Vac and ac. It is the portion of the total voltage from source to utilization equipment assigned for the distribution bus to utilization equipment. The voltage drop of RPC's was selected using .5 volts for dc and 1.5 volts for ac. (Actual voltage drop varies as a function of load and only equals this specification limit under load at the full RPC rating.) See Table A2-1.

Other Tables

Tables A2-2 and A2-3 are documentation of the wire weight and resistance used in this Appendix and in Section 3 calculations of Orbiter umbilical weights. Table A2-4 tabulates the number of connector pins and their weight for the umbilical system in Section 3.

ORIGINAL PAGE IS
OF POOR QUALITY

Gauge	Amps	Ohms	Lbs/1000	28 Vdc Voltage Drop 2 -.5V = 15V			115 Vdc Voltage Drop 4 -.5 = 3.5V			270 Vdc Voltage Drop 10 -.5 = 9.5V			115 Vac Voltage Drop 4 -1.5 = 2.5V		
				Wire Length Ft.	Circuit Length Ft.	Wire Weight	Wire Length Ft.	Circuit Length Ft.	Wire Weight	Wire Length Ft.	Circuit Length Ft.	Wire Weight	Wire Length Ft.	Circuit Length Ft.	Wire Weight
26	1	40.3	2.1	37.2	18.6	.08	86.8	43.4	.18	235	117.9	.49	62	31	.13
26	2			18.6	9.3	.04	43.4	21.7	.09	117.9	58.9	.25	31	15.5	.07
24	2	25.2	2.8	21.76	11.9	.06	69.4	34.7	.19	180.45	94.25	.51	49.6	24.8	.14
24	4			14.9	7.4	.04	34.7	17.4	.1	94.25	47.1	.26	24.8	12.4	.07
22	4	16.07	3.9	23.34	11.67	.09	54.4	27.2	.21	147.8	73.9	.58	37.9	19.5	.14
22	5			18.67	9.33	.07	43.6	21.8	.17	118.2	59.1	.46	31.1	15.5	.15
20	5	9.98	5.5	30.16	15	.17	70.1	35	1.05	190.4	95.2	1.05	50.1	25	.28
20	7			21.47	10.74	.12	50	25	.75	136	68	.75	35.8	17.4	.20
18	7	6.18	8	24.4	12.2	.20	81.1	40.6	.65	220.3	110.2	1.76	57.8	28.9	.46
18	10			15	7.52	.12	56.8	28.4	.45	154.2	77.1	1.23	40.5	20.2	.22
16	10	4.83	10.1	31	15.5	.31	72.4	36.2	.73	196.7	98.3	1.99	51.7	25.9	.56
16	16			19.41	9.7	.2	45.3	22.64	.46	122.9	61.5	1.24	32.4	16.2	.35
14	16	3.06	15.5	30.64	15.32	.47	71.5	35.7	1.11	194	97	3.01	51	25.5	.79
14	18			27.23	13.62	.42	63.5	37.7	.98	172.5	86.2	2.67	45.4	22.7	.70
12	18	2.17	23	38.4	19.2	.88	89.6	44.8	2.06	243.2	121.6	5.59	64	32	1.47
12	22			31.42	15.71	.72	73.3	36.7	1.69	199	99.5	2.29	52.4	28.2	1.21

MAXIMUM CIRCUIT LENGTH BASED ON VOLTAGE DROP
FOR WIRES 26 TO 12 GAGE AT 28/115/270 Vdc AND 115 Vac

TABLE A2-1

A2-12

29817-6001-TU-00

Appendix Table A2-2

Nickel Plated Wire Weight and Resistance

20 to 26 gage - high strength 0 to 18 gage
soft plated - extra fine strands

Gage	Weight-lb/1000		Resistance ohms 50°C
	Hard Drawn Copper	Soft Copper	
26	2.1	--	40.29
24	2.8	--	25.21
22	3.9	--	16.07
20	9.07	--	9.98
18	--	8	6.16
16	--	10.1	4.83
14	--	15.5	3.06
12	--	23.0	2.17
10	--	35.7	1.37
8	--	62.8	.87
6	--	99.3	.48
4	--	153.0	.30
2	--	247.0	.20
0	--	377.0	.125

POWER UMBILICAL AND BUS INTERCONNECTION OF A POWER MODULE TO ORBITER
WIRE WEIGHT AND VOLTAGE DROP

CIRCUIT CONF' GURATION	10/12.5 KW				50/52.5 KW				100/125 KW			
	AMPS	GAGE-# OF CONDUCTORS	VOLTS DROP	WEIGHT LBS	AMPS	GAGE-# OF CONDUCTORS	VOLTS DROP	WEIGHT LBS	AMP	GAGE-# OF CONDUCTORS	VOLTS DROP	WEIGHT LBS
28V												
1	417	1/0 - 2	2.16	102	2083	1/0 - 10	2.16	509	4167	1/0 - 20	2.16	1017
2	208.5	#4 - 2	3.08	82.6	1042	1/0 - 5	2.16	520	2083	1/0 - 10	2.16	1131
120V												
1	104	#6 - 2	2.95	26.8	521	1/0 - 3	3.18	113.1	1042	1/0 - 6	3.70	305
2	52	#10 - 2	4.54	19.3	2605	1/0 - 2	3.38	82.6	521	1/0 - 4	3.38	407
270V												
1	46.3	#12 - 2	8.41	6.2	231	#4 - 2	7.45	41.3	462	1/0 - 2	7.13	101.8
2	23.2	#12 - 2	6.9	12.42	115.8	#6 - 2	7.03	53.6	231.5	4 - 2	7.48	82.6

- CONFIGURATION 1 - SINGLE BUS IN POWER MODULE SUPPLYING
SINGLE BUS IN ORBITER
- 2 - TWO BUSES IN POWER MODULE SUPPLYING
TWO BUSES IN ORBITER BAY

STRUCTURE BOND WIRE EQUALS 50% OF ONE POLARITY OF CIRCUIT OR NEAREST LARGER
INTEGRAL NUMBER OF IDENTICAL CONDUCTORS

TABLE A2-3

ORIGINAL PAGE IS
OF POOR QUALITY

29817-6001-TU-00

A2-14

TABLE A2-4

UMBILICAL
CONNECTOR WEIGHTS
POWER MODULE AND ORBITER

<u>CONFIGURATION</u>			<u>PINS -- POWER MODULE</u>			<u>PINS -- ORBITER</u>		
<u>VOLTAGE/ # OF BUSES</u>	<u>GAGE</u>	<u># OF CONDUCTORS</u>	<u>#/PINS</u>	<u>WT/PIN</u>	<u>TOTAL</u>	<u>#/PINS</u>	<u>WT/PIN</u>	<u>TOTAL</u>
<u>10/12.5 kW</u>								
28-1	1/0	2	19	.8	15.2	13	10.4	25.6
28-2	#4	2	38	.6	22.8	26	15.6	38.4
120-1	#6	2	19	.5	9.5	13	6.5	16.0
120-2	#10	2	38	.2	7.6	26	4.6	12.2
270-1	#12	2	19	.1	1.9	13	1.3	3.2
270-2	#12	2	38	.1	3.8	26	2.6	6.4
<u>50/62.5 kW</u>								
28-1	1/0	10	95	.8	76.0	65	60.8	136.8
28-2	1/0	5	48	.8	38.4	33	26.4	64.8
120-1	1/0	3	24	.8	19.2	14	11.2	30.4
120-2	1/0	2	19	.8	15.2	13	10.4	25.6
270-1	#4	2	19	.65	12.35	13	8.45	20.8
270-2	#6	2	38	.5	19.0	26	13.0	32.0
<u>100/125 kW</u>								
28-1	1/0	20	190	.8	152.0	130	104.0	256.0
28-2	1/0	10	85	.8	68.0	65	52.0	120.0
120-1	1/0	6	51	.8	40.8	39	31.2	72.0
120-2	1/0	4	34	.8	27.2	26	20.8	48.0
270-1	1/0	2	19	.8	15.2	13	10.4	25.6
270-2	#4	2	38	.6	22.8	26	15.6	38.4

Dc System of 500 Circuits for 100 kW

System weights were calculated for wire based on aircraft usage for 500 circuits delivering 100 kW at three dc voltages and are compared in Table A2-5. Table A2-6 allocates the percent of 500 circuits allocated for each wire gage 12 to 26 gage for each voltage 28, 115 and 270. All wires were assumed to be 17.4 feet long which is the shortest 115 volt conductor that meets the criteria used in preparing the tables. The criteria was applied that distribution to utilization equipment would have a 200 percent diversity over the 100 kW source capability used. Connectors were not included in the comparison. The 28-volt system has the least margin for load diversity. The 270 volt system could not be tailored closer to the 200 kW distribution capability target because 80 percent of the circuits were already on the smallest gage wire presumed to be permissible due to mechanical reasons. 28 volt ac systems are not practical when 1.5 volt RPC's are selected. If a transistor RPC for ac were developed that approached the .5 volt drop realizable for dc 28 vac systems ac could be projected. If hybrid RPC were available, the 115 volt ac system would come out approximately equal to the 115 volt dc system in weight. More power can be transmitted for a given wire weight with 3 phase ac than with two wire dc since some loads are 3 phase which allows use of smaller gage wires. The hybrid RPC would have a low forward drop that would be like the present power contactors and relays. When considering wire gages above 12 gage the effect of line reactance in main feeders will add to the weight of main feeders for constant voltage drop or 12 volts for ac versus 8.5 volts for 270 vdc. This is not significant for systems of 100 kW with 3 or more main feeders for distances less than 200 feet. (125 kW is 204 amps if three circuit and 90.6 if four circuit.) Ac protection can operate with less I^2T let through to a fault due to the shorter circuit protection trip time possible which in turn permits use of bundled smaller conductors for each phase reducing the inductance over that required for single wire.

The power deliverable from a source when examined at the utilization equipment distribution bus or buses would be twice the source power capability as a rough approximation. This was illustrated in the discussion on wire sizing parameters. If the 500 wires of the 28 volt system do not include loads larger than 336 watts, the total copper capacity of the 500 circuits would only have an ultimate current times voltage capacity of a little over 115 kW. To make allowances for the desired diversity between source and distribution bus conductors, an additional unspecified number of larger conductors would be required to carry the desired 100 kW to the utilization equipment. The 28 volt copper weight was doubled to account for these loads over 336 watts. Thus the measure of the 28 volt system capacity would become 230 kW when represented by the sum of the conductors current multiplied by the system voltage. Table A2-5 tabulates such a power capacity in kilowatts with the weight of each system.

<u>Voltage</u>	<u>Weight</u>	<u>Power</u> (Summation of current times system voltage)
28V	387 lbs.	230 kW
115V	101.5 lbs.	295 kW
270V	57.7 lbs.	353 kW

TABLE A2-5

Increasing power capacity as a function of voltage is a measure of the reserve margin provided by the higher voltage system to the extent that they exceed the goal of 200 kW. Reserve margin in copper reduces the heating contributed by voltage drop line losses in absolute terms and as a percentage of the system losses.

* TABLE A2-5
 PERCENT OF 500 CIRCUIT SYSTEM ALLOCATED
 TO 28 VOLT, 115 VOLT AND 270 VOLTS DC
 FOR WIRE 12 TO 26 GAGE OF 17.4 FEET CIRCUIT LENGTH

GAGE	AMPERES	28V %	28V* WEIGHT	115V %	115V WEIGHT	270V %	270V WEIGHT
26	1	15	6.00	40	14.43	60	21.69
26	2	5	3.35	10	3.61	20	7.39
24	2	8	5.37	6	2.86	2	.94
24	4	4	7.99	2	1.00	1	.48
22	4	6	4.03	6	4.03	2	1.37
22	5	2	3.73	2	1.36	1	.68
20	5	8	9.26	8	20.86	2	1.92
20	7	4	6.96	4	10.44	1	.96
18	7	8	13.92	6	9.96	2	2.78
18	10	3	5.38	5	6.89	1	1.51
16	10	8	31.35	4	7.02	1	.35
16	16	4	10.73	1.5	2.66	2	3.51
14	16	10	26.83	3	8.12	1	2.7
14	18	5	19.94	1	2.26	2	5.39
12	18	8	31.9	1	4.00	1	4.00
12	22	2	6.40	5	2.00	1	2.00
Total weight/lbs			<u>193.40</u>		<u>101.5</u>		<u>57.7</u>

*Weight tabulated is for least larger gage than meets 3.5 volt drop for 17.4 feet.

APPENDIX A-3
REFERENCES

1. Space Vehicle Electrical Power Processing Distribution and Control Study Contract NASA-26270, June 1972, by A. Krausz.
2. HZN - NASA SP-208, The Prevention of Electrical Breakdown in Spacecraft, NASA 1969, Fred W. Paul and Donald Burrowbridge, et. al.
3. 73-89467, Transient Performance of Electrical Power Systems, by Reinhold Rüdénberg.
4. PC17C Fuel Cell Power Plant for Auxiliary Payload Power Systems, PWA-5179 22, November 1974, Pratt Whitney Aircraft.
5. Hydrogen-Oxygen Alkaline Fuel Cells, P. Bolan and B. Gitlow, National Fuel Cell Seminar, June 1977.
6. JSC 11123, Space Transportation System Payloads Safety Guidelines Handbook, July 1978.
7. 00303 Fuel Cell Power Systems for Ocean Application, B. Gitlow, United Technologies, Power Systems Division, July 1975.
8. Analysis of Effects of Shadowed and Open Solar Cells on Orbital Workshop Solar Cell Array Performance, P. L. Jett Space Support Division, Sperry Rand Corp., J. L. Miller Marshall Space Flight Center, NASA 719118.
9. The Line Pass and Seymour, Inc., Form 3429 GMD 12-74.
10. SAMSO Pamphlet 127-5, SAMSO Standard Satellite System Safety Design Criteria, 1 March 1973.

APPENDIX A-4

BIBLIOGRAPHY

1. Electrical Component Technology for 1/4 to 10 1/4 to 10 Megawatt Space Power
A. E. King, J. B. Fanger Westinghouse Electric Corporation Lima, Ohio
G. S. Leighton U. S. Atomic Energy Commission Washington D. C. 689040.
2. Power Conditioning Requirements and Trade-Off Considerations for the Space Shuttle W. B. Collins and D. R. Newell Martin Marietta Corp. Denver, Colorado.
3. 729100 Modularised Power Conditioning Units for High Power Satellite Applications D. M. O'Sullivan and A. Capel ESTEC Domeinweg-Noordwijk, Holland.
4. 699010 Power Systems for The Appollo Applications Program D. L. Daubert and W.H. Gross Martin Marietta Corp. Denver. C. B. Graff and J. D. Murrell NASA Huntsville, Alabama and Houston, Texas.
5. Skylab Electrical Power System Charles Graff and Roy Lanier, Jr. George C. Marshall Space Flight Center, NASA 719023.
6. System Design Considerations for a 25kW Space Station Power System. Gary F. Turner Manager Alan K. Johnson and Martin G. Gandel Staff Engineers. Electrical Power Systems Department (62-25) Lockheed Missiles & Space Company Inc. Sunnyvale, California 729074.
7. AFAPL-TR-74-86 Influences of Solid-State Electrical Distribution on Aircraft Power Generation Solid-State Power Controller Compatibility S. Dawson, R. Urdanivia, J. E. Phillips Rockwell International Los Angeles November 1974.
8. Conceptual Design of Space Base Electrical Power System Vernold K. Feiste NASA Manned Spacecraft Center Houston, Texas August 1969.
9. Spacecraft Design for the SBS System M. T. Lyons Assistant Director, RF Systems Engineering Satellite Business Systems McLean, Virginia P. C. Dougherty Assistant Program Manager Hughes Aircraft Company Los Angeles, California HS376.
10. Advanced Photovoltaic Synchronous Orbit Spacecraft Power Systems Paul Goldsmith and George M. Reppucci TRW Defense and Space Systems Group Redondo Beach, Ca.
15. Status of the NASA Space Power Program J. P. Mullin Chief, Space Power and L. B. Holcomb Manager, Chemical and Thermal Power NASA Headquarters, Washington D. C.
16. 749020 Solar Electric Propulsion Spacecraft Power Subsystem for an ENCKE Comet Rendezvous Mission E. N. Costaque Jet Propulsion Laboratory Pasadena, Ca.
17. AC Generator Air-Cooled Brushless Type High Power - High Reliability Nominal 400 H_z Westinghouse.
18. Power by Wire for Aircraft the All Electric Airplane C. W. Helsley Jr. Rockwell International Nov 1-17 1977.
19. 77-493 Future Trends in Air Force Aircraft Electrical Power Distribution and Control E. Caputo And D. Fox Aero Propulsion Lab. Wright-Patterson AEB, Ohio AIAA Conference on The Future of Aerospace Power Systems St. Louis, Mo. March 1977.
20. Avionics Maintenance Conference N 73-059/MXX-00 Second Seminar of AMC '73 SFO Meeting Covered Subject of "Transients in Aircraft Electrical Systems and Their Effect on Avionics Equipment R. C. Kuntz, W. S. Smost, et al. 4/73.

21. NAS 12-659 68-417 (7) Investigation and Development of New Concepts for Improvement of Aircraft Electrical Power Systems K. M. Chirgwin
Airesearch Manufacturing Company Los Angeles Cal.
22. Parametric Charge Studies for Aerospace Nickel Cadmium Batteries K. E. Preusse, R. C. Shair, F. E. Betz and J. Sylvia Gulton Industries, Inc.
Metuchen, N. J. 08840
23. Two Year Flight Performance of the Lockheed Type XI Nickel-Cadmium Battery
Michael J. Teresa and Robert E. Corbett Lockheed Missiles & Space Company
Sunnyvale, Ca.
24. Energy Storage Requirements for An Advanced Missile System R. R. Chevron and D. V. Noren TRW Systems, Redondo Beach, Ca.
25. Military Standard Electrical Conductivity Test For Measurement of Heat Treatment of Aluminum Alloys, Eddy Current Method MIL-STD-1537 (USAF) 7
February 1973 FSC MISC.
26. Nickel-Hydrogen Battery System M. Klein and B. S. Baker Energy Research Corporation 15 Durant Ave. Bethel, Conn. 06801.
27. Nickel-Hydrogen Battery Development for Synchronous Satellites M. G. Gandel and R. Chang Lockheed Missiles & Space Co., Inc. W. C. Harsch Eagle-Picher Industries Joplin Mo. 749066.
28. NASA Case No. 12, 039-1 Multi-Cell Battery Protection System Ralph D. Thomas and William J. Nagle May 19, 1976.
29. 759192 Microprocessor-Controlled Battery Protection System M. S. Imamura, R. L. Donovan, et. al Martin Marietta Corp. Denver, IECEC '75 Record.
30. Parametric Charge Studies for Aerospace Nickel-Cadmium Batteries K. E. Preusse, et al. Gulon Industries Inc. Metuchen, N. J. September 1969.
31. Improved Charging Methods for Nickel-Cadmium Batteries Used in Satellites. C. E. Thomas and C. J. O'Callaghan Chrysler Corp. Space Div. New Orleans, Louisiana.
32. Allis-Chalmers an Integrated System for Space Station Life Support, Power and Propulsion.
33. 739020 Electrolytic Hydrogen Fuel Productions with Solid Polymer Electrolyte Technology W. A. Titterington & A. P. Fickett General Electric Co. Lynn, Mass.
34. 72907 The Solid Polymer Electrolyte Fuel Cell for The Space Shuttle Orbiter Lloyd E. Chapman General Electric Company Lynn, Mass.
35. Fuel Cells Progress Toward Commercial Applications D. L. Douglas and H. A. Liebafsky General Electric Co.

36. Hydrogen Cycle Peak-Shaving on the New York State Grid Using Fuel Cells
R. A. Fernandes H. D. Phillip Niagra Mohawk Power Corporation March/April
1977.
37. Unitized Solid Polymer Electrolyte Regenerative Fuel Cell For Synchronous
and Low Orbit Energy Storage Applications Aircraft Equipment Division
General Electric Lynn, Mass October 1970.
38. NASA CR-66654 Design and Fabrication of a Water Electrolysis Unit For an
Integrated Life Support System Allis-Chalmers August 1968.
39. Tor Windage Losses for Lundell Alternators H. Gorland and Erwin E. Kempke
Jr. Lewis Research Center National Aeronautics and Space Administration
Cleveland Ohio....729059 page 341.
40. Experimental Windage Studies for High-Speed Alternators S. H. Gorland and E. E.
Kempke, Jr. Lewis Research Center, NASA 719056
41. IEEE Transactions on Aerospace-Support Conference Procedures - Summer 1967.
Flux Distribution in Saturated High-Speed Homopolar Inductor Alternators
with Purely Reactive Loads E. A. Erdelyi, F. C. Trutt Department of El. Eng.
University of Delaware R. E. Hopkins Electrical Power Branch U. S. Army
Engineer Res. and Dev. Laboratories.
42. IEEE Transactions on Aerospace-Support Conference Procedures - Summer 1963
Analytical Design Method for Lundell Alternator Edward Halas Senior Member
IEEE U. S. Army Engineer Research & Development Labs Fort Belvoir, VA.
43. A Discussion of the Wanlass Motors by Cravens L. Wanlass December 20, 1977.
44. NASA Contract NAS8-26270 Space Vehicle Electrical Power Processing Distribution
and Control Study, Fourth Progress Report December 7, 1971.
45. 729073 A Solar Array and Battery Electrical Power Subsystem for the Shuttle-
Launched Modular Space Station W. E. Murray McDonnell Douglas Astronautics
Systems.
46. KIPS Kilowatt Isotope Power System ERDA-Nuclear Research and Applications
Division E. C. Krueger, R. F. McKenna, R. E. Niggemann Sundstrand Advanced
Technology Group F. A. Russo Teledyne Energy Systems 11th IECEC.
47. APS 2001-R Final Report Space Station Study Nuclear Brayton Power Conversion
Assembly North American Rockwell by Airesearch MFG. Co. of Arizona July, 1970.
48. Gaseous Fuel Reactor Systems for Aerospace Applications K. Thom and F. C.
Schwenk NASA Hqs. AIAA Conference March 1977.
49. 77-508 Nuclear Powered Satellite Design for Shuttle Launches M. H. Kaplan
Penn. State University AIAA Conference March 1977.
50. Nuclear Safety Considerations on the Design of a Fast Reactor for Space
Electric Power and Propulsion T-M Hsieh, Jet Propulsion Lab. D. R. Koenig,
Los Alamos Scientific Lab. AIAA Conference March 1977.

51. Design Considerations for Non-Destructible Fault Current Breakers in Land Mobile Power Converter Systems. Eberhart Reimers Electrical Equipment Division USAMERDC Fort Belvoir, Virginia 22060.
52. Circuit Breakers Physical and Engineering Problems W. Rieder Brown, Boveri & Co., LTD.
53. NASA SP-5942 (01) Technology Utilization DC Power Circuits a Compilation National Aeronautics and Space Administration.
54. NASA Technical Memorandum NASA TM X 68248 B. L. Sater and T. J. Riley Lewis Research Center Cleveland, Ohio 44135 Wm. Janssen Sterer Engineering and Manufacturing Company Los Angeles, California 90038 Development of a Hybrid Microelectronics Solid State Relay for 2500 Volts Isolation 120°C to 80°C Thermocycling Range.
55. Inductive Transient Suppression of Relay Coils Leach Corporation Relay Division.
56. Relay Facts Edward U. Thomas Gruman Aircraft Engineering Corp.
57. F 76 380-6 IEEE Transactions on Power and Systems Current Chopping Phenomena of Medium Voltage Circuit Breakers M. Murano, S. Yanabu, et al. Tokyo Shibaura Electric Co., Ltd. April 1976.
58. Circuit Breakers Physical and Engineering Problems W. Rieder Brown, Boyeri & Co., Ltd. IEEE Spectrum July 1970.
59. 77-520 High Power Spark Gap Switches-A Numerical Model and Experimental Investigations R. E. Ponsonby, University of Michigan, J. Heckl Naval Weapons Center AIAA Conference March 1977.
60. Tomorrow's Relay Today -- The Balanced Force J. C. Schuessler A. O. Adams Leach Corporation Los Angeles.
61. Pre-Test Determination of Current for Maximum Thermal ARC Energy Release in Current Limiting Fuses. H. W. Mikulecky, Senior Member IEEE RTE Corp. Waukesha, Wisconsin.....PAS-95, No. 1, January/February 1976.
62. Solar Cell Power Systems for Manned Space Stations H. Weiner, Senior Engineer Advance Secondary Power Systems Branch Research and Development McDonnell Douglas Astronautics Company-Western Division. Santa Monica, California 699008
63. NASA TM X-3566 Integrally Regulated Solar Array Demonstration Using an Intel 8080 Microprocessor Edward J. Petrik Lewis Research Center July 1977.
64. 68907 Lunar Surface Solar Array Characteristics R. Boring TRW Systems Group.
65. 689078 Large Solar Arrays for Multi-Mission Lunar Surface Exploration J. E. Boretz TRW Systems Group.

66. NASA TM X-71860 NASA Technical Memorandum Laboratory 15 KV High Voltage Solar Array Facility Joseph C. Kolecki & Suzanne T. Gooder Lewis Research Center January 1976.
67. NASA TM X-3566 Integrally Regulated Solar Array Demonstration Using an Intel 8080 Microprocessor.....Edward J. Petrik, Lewis Research Center July 1977.
68. 699008 Solar Cell Power Systems for Manned Space Stations H. Weiner McDonnell Douglas Santa Monica.
69. 77-510 A Rationale for Large Space-Based Solar Power Systems Jerry Grey AIAA Conference on The Future of Aerospace Power Systems March 1977.
70. LMSC-A981518 31 December, 1970 Solar Cell Technology Study R. V. Elms Lockheed Missils & Space Company.
71. Corona Resistant "Teflon" for High Voltage By W. L. Gore & Associates, Inc. Newark Del.
72. Interpretation of Sparking Potentials in Accordance With Paschen's Law and Effects on Spacecraft Electrical Equipment By M. W. Raybin Military Systems Design Oct. 1963.
73. 77-520 High Power Spark Gap Switches-A Numerical Model and Experimental Investigations, J. F. Driscoll and R. E. Ponsonby, University of Michigan Ann Arbor, Michigan and J. Heckl, Naval Weapons Center Silver Springs, MD. AIAA Conference on the Future of Aerospace Power Systems. St. Louis Mo. March 1-3, 1977.
74. IEEE Transactions on Power Apparatus and Systems, Vol. PAS-95, No. L, January/February 1976. Partial Discharge Characteristics of Oil-Immersed Insulation Systems Under DC, Combined AC-DC and DC Reversed Polarity Voltage E. Takahashi Y. Tsutsumi Hitachi Research Laboratory, Hitachi LTD Ibaraki Ken, Japan, K. Okuyama Kokubu Works Hitachi LTD. Ibaraki Ken, Japan F. Ogata Hitachi Works, Hitachi Ltd. Ibaraki Ken Japan.
75. IEEE Transactions on Parts, Hybrids, and Packaging, Vol. PHP-9, No. March 1973. A Brief Review of Arcing and Interruption Phenomena in Vacuum. Clive W. Kimblin.
76. Electrical Noise in Machine Tool Controls Merle R. Swinehart Cutler-Hammer Milwaukee.
77. Switching in Vacuum: A Review Amos Selzer Cutler-Hammer, Inc.
78. NASA TM X-52811 NASA Technical Memorandum Reduction of Alternator Apparent Power Requirements and Harmonic Distortion Caused By Phase-Controlled Parasitic Loads, Leonard J. Gilbert and Dennis A. Perz Lewis Research Center Cleveland, Ohio.
79. Auxiliary Power Units and Their Application To The Space Shuttle C. Dale Haines NASA Manned Spacecraft Center Houston, Texas 77058

80. Development and Flight Test of A Hydrazine-Fueled Turbo-Alternator Power Supply. David J. Hucker Group Engineer, Research Sunstrand Aviation IECEC 68 689133.
81. High Frequency Motors for Electric Propulsion Richard D. Thornton Department of Electrical Engineering Massachusetts Institute of Technology.
82. An Inductor Alternator Rotor For Space Application Jack L McCabria Westinghouse Electric Corporation Aerospace Electrical Division. Lima, Ohio IECEC 68
83. Modularized Power Conditioning Units for High Power Satellite Applications. D. M. O'Sullivan and A Capel Energy Conversion Division ESTEC Dordrecht-Noordwijk Holland 729100.
84. IEEE Transactions on Power Apparatus and System, Vol. Pas-95, No. 3, May/June 1976. Inverters for Commercial Fuel Cell Power Generation G. A. Phillips J. H. Vogt, J. W. Walton United Technologies Corporation South Windsor, Connecticut.
85. Time Optimal Response Control of A Two-Pole Single Phase Inverter Manvel A Geyer, Fellow Engineer Aerospace Electrical Division Westinghouse Electric Corporation Lima Ohio. Address Kernick, Fellow Engineer Aerospace Electrical Division Westinghouse Electric Corporation Lima Ohio.
86. VS70-976102, Integrated System Schematic Orbiter, OV-102 Electrical Power Distribution and Control Space Division, Rockwell International.
87. Modular, High Power, Variable R Dynamic Electrical Load Simulator Final Report Program Period 28 June 1973 to 20 June 1974. Contract Number NAS 9-13495 AVSD 0170-74-RR 24 June 1974 AVCO GOV Products Dept. Wilmington Miss.
88. Technical Report 68105 Royal Aircraft Establishment, May 1965 Preliminary Assessment of Methods of Switching for a Proposed 200 volt dc Aircraft Power System. MH Walshaw - BSC. T. R. Andrews, R. H. Forrest & P. A. Shockels.
89. APL-TDR-64-53 Investigation of Power Conversion and Generation Techniques Technical Documentary Report No. APL-TDR-64-53 May 15, 1964. Research and Technology Division Air Force Systems Command Wright-Patterson Air Force Base, Ohio. Project No. 8128, Task No. 812808.(Prepared Under Contract No. AF33(657)-11049 by North American Aviation, Inc., Los Angeles Cal. Div. 9009
90. Thyristor Commutation in DC Choppers A Comparative Study William McMurray General Electric Company Schenectady, Ny. William McMurray.
91. Conference Paper Dynamic Converters for Aerospace Use J. T. Duane Member AIEE General Electric Company. Erie, PA. CP 62-1157.
92. A Novel Equidistant Pulse Control Scheme for Thyristor Converters Paresh C. Sen Senior Member IEEE Murray MacDonald, Student Member IEEE Douglas J. Clarke

93. U. D. C. 537.523.5: 533.6015.4/5: 621.3.024, Royal Aircraft Establishment R. F. Sims and R. L. A. McKenzie, The Effect of Altitude on AR Length in 200 Volt ac and dc System, dated Nov. 1969.
94. Space Station Study Informal Report #2, Selected PCM Preliminary Design Concept for North American Rockwell P. O. M9W8XDZ-68004-D APS-5349-R June 1, 1970.
95. Design Ideas Voltage Monitor Protects Against Power-Supply Failures John E. Draut Intersil, Inc. Sunnyvale November 20, 1977.
96. 749137 High-Voltage Connections for Flight Vehicles W. G. Dunbar The Boeing Company.
97. Electrical Energy Losses In Power Systems H. N. Hickok, General Electric Company Houston, Texas IAS 77 Annual
98. IEEE Transactions On Aerospace/Volume 2 Number 2, April 1964 pg. 998. Currents and Voltages in the Power Switches of Static Inverters Stanley Y. Merritt Specialty Control Department General Electric Company.
99. Millisecond Zero Line Current and Large Line Current Phase Shifts From SCR Switching of Three Phase Voltage Sources. George W. Allen, Member, IEEE Paper 69 TP 43-IGA, Approved by The Static Power Converter Committee of The IEEE IGA Group for Publication in the Transactions Manuscript Received April 6, 1971. The Author is with Systems Development Division, IBM Corp. Kingston, N. Y. 12401.
100. Interfacing Utility Supplied Power With Critical Loads Phillin L. Wheeler Supervising Distribution Engineer Southern California Edison Company.
101. NASA CR-2383 NASA Contractor Report Integrated Power/Attitude Control System (IPACS) Study Volume I - Feasibility Studies By: J. E. Notti, A. Carmack III and W. C. Schmill Prepared by Rockwell International Space Division Downey, Calif. 90241 For Langley Research Center.
102. Electrical Power Subsystem for the Nato III Communications Satellite H. N. McKinney and D. C. Briggs Aeronutronic Ford Corporation, Palo Alto Cal. page 1408 11th IECEC.
103. Department of the Navy, Naval Air Development Center Warminster PA 18974 Specification No. NADC-VT-TS-7502, Generator System, 270 Volts Direct Current, Oil Cooled Aircraft, General Specification for, Howard Ireland, Joseph D. Segrest, and Leonard A. Fuchs.
104. NRL Report 7126 An Assessment of High-Voltage DC Electrical Power in Aircraft Electrical Systems, B. J. Wilson and J. P. O'Connor, July 1, 1970.
105. Influence of Electric Power Quality on Avionic Design and Weapon System Effectiveness, J. S. Frichtel General Electric Utica, New York.

106. A Hybrid Electrical Power System for Aircraft Application, C. H. Lee, C. Y. Chin, Airesearch Manufacturing Company, Torrance, California.
107. Battery and Cell Redundancy Considerations for Long Duration Space Missions, Peter Fono/Power Systems Department, Technology Division, Space and Communications Group, Hughes Aircraft Company, El Segundo, California.
108. 699009 Optimization of Battery Subsystems for Earth Satellite Lifetimes of Greater than Five Years, Monty Koslover, TRW Redondo Beach, CA.
109. Orbital Performance of NTS-2 Nickel-Hydrogen Battery, J. D. Dunlap and J. F. Stockel, Comsat Laboratories, August 1977.
110. SPR-014, 30 October 1970, Fuel Cell Technology Program Contract NAS 9-11033 Aircraft Equipment Division, General Electric, Lynn, Mass.
111. Recent Improvements in Water Electrolysis with a Solid Polymer Electrolyte Acid System.....Albert C. Erickson, Arnold P. Fickett, et. al General Electric, Lynn, Mass. September 1970.
112. AAS 75-143 Lightweight Fuel Cell Powerplant for Tug....Lawrence M Handley United Technologies Corp. August 1975.
113. 729067 Status of Shuttle Fuel Cell Technology Program William E. Rice and David Bell III Manned Spacecraft Center Houston Tex.
114. Common Avionic Subsystem Considerations John G. Gregory and Dr. Manvel A Geyer Westinghouse Defense and Electronic Systems Center Baltimore, Maryland.
115. Automatically Controlled Electrical Systems System and Operational Description Westinghouse Electric Corp. October 1972.
116. Navairdevcen Specification AEE-09 General Specification for Generator System 120 or 240 Volt, Direct Current, Aircraft Engine Driven, High Speed..... R. Howard Ireland Department of the Navy.
117. 729074 System Design Considerations for A 25KW Space Station Power System Garv F. Turner Alan K. Johnson and Martin G. Gandel Lockheed Missiles & Space Company, Sunnyvale, Calif.
118. WAED 64.13E Manned Orbital Space Station Power Conversion and Control Systems Westinghouse Electric Corp. Lima, Ohio.

119. B74-10069 Self-Protecting Solid-State Isolated Switch Hoffman, A. C. & Gooder, S. T. NASA Tech Brief August 1974.
120. NASA Technical Memorandum NASA TM X-73505 Series-Parallel Method of Direct Solar Array Regulation S. T. Gooder Lewis Research Center Cleveland, Ohio 44135 September 1976...(NASA-TM-X-73505) Series-Parallel Method of Direct Solar Array
121. Electrical Transient Impact On Energy Costs and Safety Transient-Suppression Devices in An Electrically Active Environment can Protect Equipment and Save Energy. Walton H. Hershfield, P.E. Consultant, Panomax Corp., San Rafael, CA
122. The "Hot" Spot Failure Mode for Solar Arrays F. A. Blake and K. L. Hanson General Electric Space Systems Organization Valley Forge Space Center P. O. Box 8555 Philadelphia Penna 19101 699070
123. High Voltage Solar Array Operation in the Ionosphere Kenneth L. Kennerud Boeing Company Seattle.
124. N71-11048 72-297 High Voltage Solar Array Configuration Study G. B. Herron, et al Hughes Aircraft Company El Segundo, Calif. July 1970.
125. N70-35719 72-221 Study of High Voltage Solar Array Configurations with Integrated Power Control Electronics T. Ebersole, et al. General Electric Co. June 1970.
126. NASA CR-72675 High Voltage Solar Array Study W. Knauer J. R. Bayless, G/T. Todd and J. W. Ward Hughes Research Laboratories May 1970.
127. LMSC-D384253 NAS8-30315 Solar Array Technology Evaluation Program for Solar Electric Propulsion Stage R. V. Elms, Jr. August 13, 1974.
128. 719115 Integration of Solar Array and Power Conditioning Electronics W. F. Springgate The Boeing Co.
129. 689075 A Design Concept for a 30 Watts Per Pound Rollup Solar Array N. F. Shepard, Jr. & K. L. Hanson General Electric Company Space Systems Org.
130. Types of Insulation Breakdown by Murray Olyphant, Jr., Electrical Products Laboratory, Minnesota Mining and Manufacturing Co., St. Paul, Minn.
131. Riddell, J. III, "High Voltage DC Secondary Power Systems Concepts for Future Naval Aircraft," N62269-74-C0157, NADC, 1974, P4C-6.
132. Military Standard Electroexplosive Subsystems, Electrically Initiated, Design Requirements and Test Methods MIL-STD-1512 (USAF) Notice 1 January 6, 1976.
133. MIL-STD-1541 (USAF) Military Standard Electromagnetic Compatibility Requirements for Space Systems FSC EMCS 15 October 1973.
134. Military Standary System Safety Program for Space and Missile Systems MIL-STD-1574 (USAF) 15 March 1977.
135. MIL-STD-1522 (USAF) MILITARY Standard, Standard General Requirements for safe design and Operation of Pressurized Missile and Space Systems.

136. Solid State Remote Power Controllers for High Voltage DC Distribution Systems, W. W. Billings, Westinghouse Electric Corporation, Lima, Ohio 45802, G. R. Sundberg, National Aeronautics & Space Administration, Cleveland, Ohio, 44135 Development Sponsored by NASA Lewis Research Center Contract NAS3-20083.
137. 77-494 Remote Power Controllers for the NASA Space Shuttle Orbiter, D. A. Fox, Westinghouse, Lima, Ohio, AIAA Conference on the Future of Aerospace Power Systems, St. Louis, Missouri, March 1977.
138. VFW-Fokker ERNO Modular Spacelab Issue No. 10.08.76 Power Quality, Wappler.
139. Electrical Power Generation Subsystem for Space Shuttle Orbiter, M. F. Blaski, Rockwell International, S. L. Owens, NASA.
140. Switching in Vacuum a Review AMOS Selzer Cutler-Hammer, Inc., Revised Text of a paper presented at the 21st Electronic Components Conference, Washington, D. C., May 10-12, 1971.
141. 1977 IEEE Power Electronics Specialist Conference, June 1977, The Solid-State Remote Power Controller: Its Status, Use and Perspective, G. R. Sundberg NASA-Lewis Research Center, W. W. Billings, Westinghouse.
142. Electrical Transient Impact On Energy Costs and Safety Transient-Suppression Devices in An Electrically Active Environment Can Protect Equipment and Save Energy. Walton H. Hershfield, P.E. Consultant, Panomax Corp. San Rafael, CA.
143. Sundberg, G. R. and Baker, D. E., "Solid State Remote Power Controllers for 120VDC Power Systems," 24th National Relay Conference, 1976, P8.
144. The Line Pass and Seymour, Inc., Form 3429 GMD 12-74.