

NASA CONTRACTOR
REPORT

"Made available under NASA sponsorship
in the interest of early and wide dis-
semination of Earth Resources Survey
Program information and without liability
for any use made thereof."

78-10209
CTR-150726

NASA CR-150726

REMOTE SENSING APPLICATIONS TO MISSOURI ENVIRONMENTAL
RESOURCES INFORMATION SYSTEM

By Robert E. Myers
Missouri Department of Natural Resources
Division of Geology and Land Survey
P. O. Box 250
Rolla, Missouri 65401

Final Report

January 15, 1978



Prepared for

NASA - GEORGE C. MARSHALL SPACE FLIGHT CENTER
Marshall Space Flight Center, Alabama 35812

(E78-10209)	REMOTE SENSING APPLICATIONS TO	N78-31507
MISSOURI ENVIRONMENTAL RESOURCES INFORMATION		
SYSTEM Final Report (Missouri Dept. of		
Natural Resources) 114 p HC A06/MF A01		Unclas
	CSSL 05B G3/43	00209

Media available under NASA sponsorship
In the interest of early and wide dis-
semination of Earth Resources Survey
Program information and without liability
for any use made thereof.

1. REPORT NO. NASA CR-150726		2. GOVERNMENT ACCESSION NO.		3. RECIPIENT'S CATALOG NO.	
4. TITLE AND SUBTITLE Remote Sensing Applications to Missouri Environmental Resources Information System				5. REPORT DATE January 15, 1978	
				6. PERFORMING ORGANIZATION CODE	
7. AUTHOR(S) Robert E. Myers				8. PERFORMING ORGANIZATION REPORT #	
9. PERFORMING ORGANIZATION NAME AND ADDRESS Missouri Department of Natural Resources Division of Geology and Land Survey Rolla, Missouri 65401				10. WORK UNIT NO.	
				11. CONTRACT OR GRANT NO. NAS8-31766	
12. SPONSORING AGENCY NAME AND ADDRESS National Aeronautics and Space Administration Washington, D. C. 20546				13. TYPE OF REPORT & PERIOD COVERED Contractor Report Final	
				14. SPONSORING AGENCY CODE	
15. SUPPLEMENTARY NOTES					
16. ABSTRACT A general overview of requirements for a Natural Resources Information System is given, including historical notes and some of the problems identified for the specific case of Missouri. A conceptual design of a Missouri Natural Resources Information System is derived, and is supported by a number of specific technical details. Alternative designs are discussed, including cost analyses. An implementation plan is given. Appendices give details and examples of Missouri's resource data.					
17. KEY WORDS Information Systems Remote Sensing Earth Resources			18. DISTRIBUTION STATEMENT Unclassified-Unlimited  J. T. POWELLE Director, Data Systems Laboratory		
19. SECURITY CLASSIF. (of this report) Unclassified		20. SECURITY CLASSIF. (of this page) Unclassified		21. NO. OF PAGES 113	22. PRICE NTIS.

TABLE OF CONTENTS

	<u>Page</u>
INTRODUCTION	1
THE GENERAL OVERVIEW OF A NATURAL RESOURCES DATA SHARING SYSTEM.....	2
HISTORY OF THE PROGRAM.....	5
PROBLEMS IN THE DEVELOPMENT OF THE NATURAL RESOURCES DATA SHARING SYSTEM.....	17
CONCEPTUAL DESIGN OF A NATURAL RESOURCES INFORMATION SYSTEM.....	19
CONCEPTUAL DESIGN OF A NATURAL RESOURCES INFORMATION SYSTEM FOR THE STATE OF MISSOURI.....	20
Present Management of Data/Information Between State Agencies.....	21
General Concepts.....	22
NRIS Users.....	22
NRIS Information Base.....	23
NRIS Services.....	24
NRIS Organization.....	25
Recommended NRIS Organization....	29
Combined Linked Network and Hierarchical Approach.....	29
Organizational Responsibilities.....	31
Overall Administrative Level Direction.....	31
Committee Level Direction.....	32
Implementation and Operation....	32
NRIS-NAWDEX Concept.....	33
NRIS Request Response Situations.....	35
Missouri Natural Resources Information System.....	36
COST ANALYSIS OF NATURAL RESOURCES INFORMATION SYSTEMS.....	37
Single Agency.....	38
Linked Network.....	39
Hierarchical Organized.....	40
Recommended NRIS.....	41
PROPOSED PLAN FOR ELECTRONIC DATA PROCESSING ACTIVITIES WITHIN THE DEPARTMENT OF NATURAL RESOURCES....	43
Main Frame Hardware.....	43
Programming and Computer Staffing.....	45
Data Links.....	46
Recommended Plan for Department of Natural Resources.....	47

Basic Plan for Fiscal Year 1979.....	49
Natural Resources Information System.....	50
Charges for Computer Services (Supplement 1).....	52
EDP Systems Committee (Figure 1).....	53
Computer Contract Form (Supplement 2).....	54
 NATURAL RESOURCES DATA SOURCE INVENTORY.....	 56
 DATA MOST FREQUENTLY USED BY MISSOURI STATE AGENCIES.....	 59
 SUMMARY OF DATA AND DATA SOURCES INVENTORY.....	 62
 INSTRUCTIONS AND CODES FOR THE INVENTORY OF NATURAL RESOURCES DATA AND DATA SOURCES IN MISSOURI STATE GOVERNMENT.....	 70
Introduction.....	71
Inventory of Natural Resources Data and Data Sources.....	72
Forms to be Completed by the Agency.....	73
Natural Resources Data Inventory Codes.....	75
Agency Key Person.....	77
Department Codes.....	78
Inventory Form.	79
 GENERAL OVERVIEW OF MISSOURI AERIAL PHOTOGRAPHY AND SPACE IMAGERY INDEX.....	 80
 MISSOURI AERIAL PHOTOGRAPHY AND SPACE IMAGERY INDEX DESIGN.....	 83
Data Preparation.....	87
File Creation and Maintenance.....	87
Index Maintenance.....	94
User Outputs.....	95
Aerial Photography and Space Imagery Index - Agency Index (Fig. 3)	97
Aerial Photography and Space Imagery Index - Library Index (Fig. 4)	99
 APPENDIX.....	 103
Aerial Photography Summary Record Form.....	104
Example Computer Printouts.....	105
Sample Listing of Index Data.....	106
Sample Graphic Representation of Index County Locations.....	108
County Overlay.....	109
Four Types of Data and County Overlay.....	110

INTRODUCTION

"Natural resources information needs have multiplied rapidly in recent years as new perspectives on the environment, energy, development patterns, and resource policy have emerged. New information users and programs have come into existence in response to these evolving perspectives. The new program information needs and the new users' skills and responsibilities present a challenge for the producers of natural resource information.

Often there is a mismatch between the needs of new users and the products available from producers. The mismatch exists for numerous reasons, including a lack of interagency coordination, narrow professional interpretations, an inability to forecast future needs, and a failure to provide timely production. The largest problem however, may be a lack of simple communication among users and producers."¹

The Inter-Departmental Council for Natural Resources Information has as its primary responsibility the solution of the above problem. The Inter-Departmental Council is administered through the Department of Natural Resources, with specific responsibilities delegated to the Division of Geology and Land Survey. This contract between NASA and the Department of Natural Resources, Division of Geology and Land Survey, recognizes two objectives: First to provide an efficient system for retrieval of remotely sensed data to be used by natural resources oriented agencies, and second to design a natural resources data system that can meet the needs of state agencies. To accomplish these objectives, this contract provides assistance for identifying natural resources

¹Natural Resource Data Needs Recommendations, the Council of State Governments

data needs and data sources; for the inventorying of remotely sensed data already available to the Division of Geology and Land Survey; and to further the study of systems already in operation which address themselves to the more efficient utilization of natural resources oriented data. It might be stated that the objective of this contract is to further the development of a natural resources data sharing system in the State of Missouri through the development of selected incremental projects which complement the overall system design.

THE GENERAL OVERVIEW OF A NATURAL RESOURCES DATA SHARING SYSTEM

One finds that the development of a natural resources data sharing system has become one of the objectives of many state governments. The system can provide various types and levels of information. Natural resources information obviously means different things to different people. To some it means the development of a computerized system having great bulks of information stored internally and ready for on-line retrieval; to some it means the development of remote sensing capabilities in line with other computer capabilities to more adequately utilize our earth resources satellites; and still to others it means a more generalized information sharing arrangement and a coordinated effort in acquisition of data. It is in this latter concept that this report envisions a Natural Resources Data Sharing System.

Every manager, no matter what level, tends to develop within his own expertise a data sharing system. This data may be created solely by himself for his own use. In addition he will draw data from other sources. He will collect files, reports and/or other data items which are necessary in his work. Some of the data that he collects will be needed by his colleague at the next

desk. This may be true even though their jobs are not in the same area of work. In some cases they may unknowingly develop the same data files independently. In a small office a formal data sharing system is not necessary, particularly in one where the individuals have a good idea of what is going on in the office-- such as what data is being developed, what data is necessary, and where additional data can be found. Even in a small operation, where a data sharing system exists but at a very basic level, the data will consist of many different formats. For instance, an engineer working on the design of a water system for a particular community will utilize topographic and other mapping of the area. He will need to know the population of the design area. This information would be in the form of a report or a computer printout from the last census tapes. The engineer, as his work progresses, will develop some detailed estimates of population projections for the area; and he will determine where he thinks new roadways might be constructed and additional residences be built. He has now created additional files for his own work--a file that would be very helpful to another engineer in the same office. The end results of the engineer's design work will be a set of plans and specifications, along with estimates of cost and projected time schedules for construction. This information in turn will be necessary data for the contracting agencies, lending institutions and governmental bodies wishing to determine proper assessment values. One can readily see that data sharing between the various components of a small operation is necessary.

As the level of management increases, it becomes more and more apparent that data must become available through a more formal or organized system. A natural resources data sharing system as envisioned in this report does not consist of

a mere computerized system, but becomes an overall coordinating body for the selection and dissemination of information. It consists of indexes of available data categorized as to area of speciality and format. The format may be computerized digital tapes, printed reports and maps, or imagery. This system would pinpoint data sources that could be mutually shared by a number of users. The system would also provide input, coordination, and pooling of funds for the development of new sources of data. The distribution of this information is extremely important and the system would also provide guidance and control of the formats of output.

Missouri has envisioned that this natural resources data sharing system would be guided by one interdepartmental agency with responsibility to the individual department directors. The agency would provide a coordinated effort not only within each one of the departments but also between each department. The study of data and data sources clearly indicates that a large number of same data items are used by a number of agencies. Of twenty agencies participating in the natural resources data sources inventory, sixteen indicated that they made fairly extensive use of special county maps. Yet these maps are made by one of the agencies without consulting any of the other fifteen; the fifteen do not participate to any large extent in the cost of preparing these maps. Obviously, in this area an effort should be made to share in the cost of the data. Many other similar instances were also indicated by the natural resources data inventory.

HISTORY OF THE PROGRAM

A study group was established in November, 1973, by Christopher S. Bond, the Governor of Missouri, with the charge to seek improved methods for coordination and utilization of certain technical data having application in the natural resources field. Such technical data was to include information traditionally categorized as "rare or extensive", as well as information currently becoming available through remotely sensed modes. This committee was identified as a Natural Resources Data Coordination Committee and its members represented nineteen state agencies. These agencies composed the bulk of those dealing with natural resources information. The committee finalized a report to the Governor on May 1, 1974. Briefly, the recommendations of that committee were as follow:

Recommendation No. 1 - A continuing permanent structure be established to provide for coordination of natural resources information with the suggestion that it be identified as the Interagency Council for Natural Resources Information, and that the Council be supported by an executive secretary provided by the Director of the Department of Natural Resources. It was also recommended that statutory definition be provided for the Council or that the Council be created by Executive Order.

Recommendation No. 2A - A natural resources data bank for state needs be developed as a primary responsibility of the Council.

Recommendation No. 2B - The development of an electronic data processing system for natural resources data be coordinated with the Division of Management Systems, Office of Administration.

Recommendation No. 3 - A primary objective be the establishment of a cartographic data and remote sensing center.

Recommendation No. 4 - The Interagency Council encourage the University sector to further develop research and instructional programs focusing on remote sensing and aerial photography in addition to the programs in natural resources.

Recommendation No. 5 - Consideration be given to the establishment of a state technical information service to serve as a source of technical reports and an interface with similar Federal programs.

Recommendation No. 6 - A pilot project be undertaken to provide the development of the initial phase of the required EDP system for natural resources data.

Under the Omnibus State Reorganization Act of 1974, Missouri state government was divided into fourteen separate and distinct departments. Each department is headed by a single director. In order to assure accountability directly to the Governor, nine of these directors are appointed by the Governor with the consent of the Missouri Senate. Their tenure in office generally is the same as that of the Governor. The other five department directors are selected by various boards and commissions which are in turn themselves appointed by the Governor. Reorganization's main thrust was to consolidate the functions of state government into proper and meaningful agencies which would decrease duplication of efforts.

Many of the nineteen state agencies represented on the Natural Resources Data Coordination Committee were scheduled for inclusion in the new Department of Natural Resources. The final committee report was delivered to the Governor approximately two months before the reorganization process began in state

government. As a result of this transition, further activity did not take place until September, 1974. At that time it was the decision of then Governor Bond to continue with the concept of an ad hoc committee without issuing any executive order or applying for legislative authority. The director of the Department of Natural Resources was directed to work with the various state departments concerned with natural resources information to establish an Inter-Departmental Council for Natural Resources Information. During the period of September, 1974 to October, 1975, the Council functioned under this directive. During this period the Council cooperated with Washington University in St. Louis to determine data sources and data needs for the various departments of state government. This project undertaken by Washington University, titled Earth Observation Data Management Systems, was funded by NASA Contract No. NAS5-20680. The Council was able to effectively assist the investigators from Washington University in preparing a Natural Resources Data Requirements Inventory for the State of Missouri. In addition to the Washington University study work, the Council made an exhaustive study of the Land Use and Data Analysis (LUDA) program, developed by the Department of Interior, and various land use classification systems.

The Inter-Departmental Council for Natural Resources Information functioned on a fairly informal basis with representation from eight departments somewhat in proportion to their assessment of the need for involvement. In October, 1975, the director of the Department of Natural Resources asked for a thorough review of the activities and structure of the Inter-Departmental Council for Natural Resources and Information. The activities of the Council were held in abeyance until all comments were received in January, 1976. As a result of these comments

the future direction of the Council was determined. It was the consensus of all departments involved that the continuation of the Council activities was highly desirable, but that the basic structure of the Council and its procedures needed to be modified in order to become more responsive to the Department Directors. The following provisions were established at that time:

1. Require at least two meetings between the Council Chairman and the Department Directors each year for review of Council activities and approval of proposed new or continued activities.
2. Each department should have one principal representative in service on the Council and that representative would have the sole vote for his department in the determination of action(s) taken by the Council. Other participation from departments was to depend upon the priority of individual department needs to participate in specific work undertaken by the Council.
3. Council's role with respect to policy matters is to continue to be limited to recommendations, which will be presented to the Department Directors by the Council Chairman in the form of memoranda when appropriate and/or the periodic meetings of the Department Directors described above. The director of the Department of Natural Resources, having the administrative responsibility for the Council, would have the responsibility of communicating recommendations to the Office of the Governor, when and if there was agreement among participating departments that such action was in order.
4. Finally, the Council should develop some achievable goals, both short- and long-term, utilizing committee structures to identify and analyze

needs; meet these if feasible within their time and support constraints, or develop appropriate recommendations outlining the problems, its priority or urgency, and the support and/or procedures required to meet these needs.

As a result of the agreement between the Department Directors, Department Representatives were appointed to the Inter-Departmental Council for Natural Resources Information, and the next meeting was held on April 1, 1976. At that meeting specific Council objectives, Council procedures, and Council committees were established. The following are a listing of the Council objectives, procedures, committees and committee objectives.

Council Objective Statement

The primary function of the Council is to coordinate the exchange and development of natural resources data. Special emphasis will be placed on data obtained by remote sensing.

Council Procedure

1. Monthly meetings of the Council representatives are to be held.
 - a) One voting member from each department on the Council.
 - b) Council meetings will be held the first Friday of each month when practical.
2. Committees are to be established to develop recommendations and programs for Council action.
 - a) These committees are to be composed of Council representatives and others with special expertise or interest in the committee's area of activity.

3. The Council approves recommendations and programs for presentation by the Council Chairman to the Department Directors, or presentation by the Director of the Department of Natural Resources to the Governor for final implementation.

Committees and Committee Objectives

1. Mapping Advisory Committee

- a) Review the status of topographic mapping in Missouri and develop Council recommendations for future mapping programs (these recommendations will be the major basis for determination of priorities for the cooperative mapping program with the U. S. Geological Survey by the State Geologist (DNR), and the Chief Engineer, Missouri State Highway Department).
- b) Review the status of all mapping programs in the State of Missouri and develop recommendations for the development of a standard base map series for use by all state departments (the proposed bases would probably be in a metric series).

2. Remote Sensing Applications Committee

- a) Study in detail the need for, and the scope of, a state remote sensing information center;
- b) Develop procedure for the coordination of the acquisition of remote sensing imagery and aerial photography;
- c) Provide coordination of research efforts in the use of remotely sensed data with state departments and universities.

3. Natural Resources Information System Committee

- a) Develop the conceptual design of a Natural Resources Information

System for use by all agencies concerned with natural resources type information.

The work of the Inter-Departmental Council and its committees is strictly on an ad hoc basis. The council has not been established by either an Executive Order or statute. It exists primarily as a result of the willingness of the department directors and those persons so designated to serve. The projects undertaken by the Council and its committees require a considerable amount of effort. The work undertaken by these individuals essentially is of a voluntary nature and must be subordinate to the individual's primary responsibilities in state government. By the establishment method of the Inter-Departmental Council, it is not in a position to receive funds or employ personnel. Therefore it is the responsibility of the individual departments to employ the appropriate personnel, supply operating funds, and make the proper requests to the Legislature for funding. The activities thus funded actually take place on the department level, but are coordinated by the Council.

Many individual tasks which complement the Council's objectives have been completed. Although not funded directly by the Council, nor participated in fully by the Council, many of these projects have utilized the coordinated effort of the Council for review and final use. A listing of these projects and a short description are as follows:

1. Index to Aerial and Space Photography Coverage in Missouri. Published by Terry W. Barney and Chris Johannsen, photography by Terry McBride, 1976. This very fine publication was produced by the Extension Division, University of Missouri-Columbia, in cooperation with the Inter-Departmental Council. Funds for developing the index were provided by the

Rural Development Center of the University of Missouri. This index includes photography flown before May 1, 1975. Only photography that is available for purchase or loan is included in this index. A map of each Regional Planning Commission and the counties therein is given in this index, along with overlays designating the various types of imagery available in those regional planning areas. Complete information is given concerning the agency descriptions, how to order the imagery, and how to use the index itself.

2. Geographic Location Referencing and Display Considerations for Proposed Electronic Data Processing of Missouri Natural Resources Information, by David Hoffman, Department of Natural Resources, under a grant from the U. S. Department of Housing and Urban Development.

This report summarizes an investigation on how natural resources data collected on map or graphic form can be handled by computer to make the information usable to more people quicker and at a lower cost. This report contains four tasks pertaining to the geocoding of information for use in a computerized natural resources information system. The four tasks are:

- a) reviewing geocoding systems in Missouri and other states;
- b) developing a catalog of all geocodes likely to be used in a natural resources information system;
- c) recommending a coordinate system and map series for digitizing all geocodes; and
- d) development of a catalog of software for geocoding data and presenting geocoded data and statistical and/or graphical output format.

3. LUDA Mapping

On June 4, 1976, the Council endorsed the Land Use and Data Analysis (LUDA) program of the Department of Interior and encouraged the state to enter into a cooperative agreement to obtain data from this program for the State of Missouri. The Missouri Office of Administration entered into an agreement with the Department of Interior to provide standard information and some special products for the State of Missouri. Standard information products to be provided are as follows:

- a) Land use and land cover maps
- b) Hydrologic unit maps
- c) Political unit maps
- d) Census districts
- e) Federal land ownership maps
- f) State Land ownership maps

These standard products will be delivered at the scale of 1:250,000.

The special products will be as follows:

- a) Maps formulated on the 20 regional planning districts for the State of Missouri;
- b) Maps showing township and range for the State of Missouri with a scale of 1:125,000;
- c) A map of the State of Missouri for each of the six standard products at a scale of 1:500,000.

The map products are currently available and digitized data should be available by the fall of 1978.

4. Natural Resources Data Requirements Inventory: Missouri, September, 1975, produced by the Center for Development Technology, Washington University, detailing a program on Earth Observation Data Management Systems, under a contract with NASA, Goddard Space Flight Center Contract No. NAS5-20680, dated February, 1975. The EODMS team and the Council agreed to work together to inventory the data needs for Missouri agencies. The two groups jointly determined from which agencies to gather information; Council members arranged initial meetings with agency representatives and the EODMS team; the EODMS team interviewed the agency representatives to determine the information needs of the agency; and they provided the Council with information obtained from their interviews and received comments. The final report is an extensive listing of task and data needs in Missouri agencies.
5. Prioritization of 15-Minute Topographic Quadrangles in Missouri. This prioritization reflects a plan developed by the Mapping Advisory Committee of the Council. The remaining 15-minute quadrangles of the topographic series for the State of Missouri that have not been scheduled for revision have been prioritized in accordance with this suggested procedure for selecting topographic maps for revision. There are presently fifty 15-minute quadrangle maps which have not been completed in a 7.5-minute format. These fifty quadrangles are ranked according to specific priority schedule using age, location and whether it is a critical area, potentially critical area, or sensitive area.

6. As a result of this contract with NASA, the following projects have been undertaken:

- a) Inventory of remote sensing imagery in the Division of Geology and Land Survey. The Division of Geology and Land Survey is the largest source in state government of remote sensing imagery for natural resource agencies. Aerial and space photographic coverage of the State of Missouri purchased by this division in past years is somewhat extensive. This information is available for use by other agencies as well as this division, and the catalog represents a first full indexing and accounting of all the imagery available to the state agencies through this division. The inventory serves as the focal point for determining the need for a remote sensing center in Missouri and for indicating the need to provide complete historical photogrammetric coverage of the state. The inventory includes photography flown by the U. S. Geological Survey, ASCS, Forest Service, NASA, and private photography.
- b) The conceptual design of a natural resources data sharing system has also been completed and submitted to the Council for adoption. This design is based upon a system being utilized in the State of Texas, which is in turn based upon the NAWDEX system being utilized nationally.
- c) The Department of Natural Resources must be one of the prime movers in the development of the Natural Resources Data Sharing System. For this reason a draft EDP plan was prepared by the Department.

- d) A detailed inventory of data and data sources within state government has been completed. Information from this inventory clearly shows the types of data and magnitude of their use that should be included in the system design.
- e) The development of a remote sensing summary record system has been designed and partly implemented. This system includes only information on data that resides in the Division of Geology and Land Survey, DNR. This system is composed of a computer listing of the remote sensing imagery and a map display of the same information.

7. Specific Budget Requests were made by the Council for FY 1978.

These requests were approved by the Council, the Department Directors, and the Legislature. This represented the first full time staff for the objectives of the Council. One professional and one secretary were employed on July 1, 1977 with this funding from General Revenue. These employees are located in the Division of Geology and Land Survey, DNR. An additional employee with expertise in remote sensing was also assigned to Council activities.

PROBLEMS IN THE DEVELOPMENT OF THE NATURAL RESOURCES DATA SHARING SYSTEM

The State of Missouri has had a very difficult time entering into the field of natural resources data sharing. At the beginning of the Council's activities the state was very decentralized and had a number of agencies involved in the gathering and use of natural resources information. With the advent of reorganization in the State of Missouri, the basic control of these agencies was reduced to eight departments. Although this represents a considerable step forward, the task of establishing a natural resources data sharing system at state level is quite ponderous. Some problems are political and some financial. One of the major problems encountered, as previously stated, was the fact that the council was an ad hoc agency existing at the mercy of the various department directors. For this reason funding and personnel are delegated directly from the various departments in proportion to their commitment to the natural resources data sharing system.

The department directors of each of the designated departments have agreed to cooperate in the development of the natural resources data sharing system. Nevertheless each department has its own interests and its own priorities. These interests and priorities are also subject to the administration currently in residence and will shift from time to time. Each department sees the value of the output and the amount of work it can delegate to such a system in a different light. The powers, duties and responsibilities of each department are specifically enumerated in the statute. It is these functions that serve as the departments' primary objective and the objectives of the Inter-Departmental Council become secondary.

One of the major problems encountered thus far with the development of the computerized phase of the information system lies with the utilization of computers in Missouri state government. Reorganization of state government established the Division of EDP Coordination under the Office of Administration. This division coordinates and controls the acquisition and use of all electronic data processing equipment. This division is charged with the development and implementation of long range computer facility plans for use of EDP; and maintains inventories and approves all additions in EDP hardware, software, support services and service centers.

The Department of Natural Resources, the Department of Agriculture and the Department of Conservation represent three of the major users of natural resource information within the Council structure. The Department of Natural Resources and the Department of Agriculture have had no computer facilities of their own to date. The Department of Conservation has had a very limited computer system which has been dedicated exclusively to financial management. In order for the computerized phase of the natural resources data sharing system to move forward, each one of the participating departments must have developed within their agency an appropriate EDP facility plan. It is for this reason that during the past year a great deal of effort has been spent by the EDP Systems Analyst in developing a plan for the Department of Natural Resources. It is recognized that the basis of a viable natural resources data sharing system must reside to a certain extent in the Department of Natural Resources and must be predicated on the availability of a computerized system within the Department of Natural Resources. Almost the entire computer activity presently going on in the Department of natural Resources is through the University of Missouri

computer system. Although this system has worked quite well on a limited scale, it is clear that a system must be developed internally within the Department of Natural Resources.

CONCEPTUAL DESIGN OF A NATURAL RESOURCES INFORMATION SYSTEM

One of the basic objectives of this contract was the development of a conceptual design of a natural resources information system for the State of Missouri. This design was prepared and recommended to the Inter-Departmental Council and to the directors for adoption. As of this date, the specific plan has not been adopted by the departments. Some consideration in the adoption of the plan was given to the alternate cost of various options. The following section contains the proposed natural resources information/data sharing system for the state and the cost analysis of the various options. In addition, the following sections contain a copy of a proposed EDP plan for the Department of Natural Resources. It was prepared recognizing that before a statewide plan could be adopted, the Department of Natural Resources needed to have a basic plan of its own. This plan was not adopted by the Department of Natural Resources, but subsequently an additional plan has been adopted allowing the department to continue with the development of its own system. At the present time the conceptual design has been returned to the Natural Resources Information Committee of the Council and they are reviewing it in light of current EDP plans in state government.

CONCEPTUAL DESIGN OF
A NATURAL RESOURCES INFORMATION SYSTEM
FOR THE STATE OF MISSOURI

PRESENT MANAGEMENT OF DATA/INFORMATION BETWEEN STATE AGENCIES

Natural resource data is consistently collected by the various State agencies in accordance with their individual statutory responsibilities. However, agency specialization alone does not identify completely the type of data that is being collected by any one agency. For this reason there has been some lack of knowledge of the existence, residence, or status of natural resources data/information. Acquiring natural resources data/information from outside one's own agency can many times be cumbersome and time-consuming, and this often causes potential users within the state agencies to forego the advantage of using all available data/information. Also, when a user has need for certain data/information but has no indication that such is already being accumulated, there is the possibility that another similar data collection program could be launched, thus constituting a duplication of effort and unnecessary expenditure of funds.

The lack of knowledge concerning existing and emerging data extends to generating sources other than state agencies, i.e., cities, regional governments, other states, and federal agencies. In cases involving the acquisition of federal agency data/information, there are multitudinous avenues of approach through the various federal agencies. Attempts by individual State agencies to obtain valuable data/information from federal sources have at times resulted in unnecessary repetition of efforts and multiple financial outlays by the State of Missouri for the same data.

Missouri citizens, as potential users, are afforded access to available data/information generally on a "search and find" basis. Considerable time and expense can many times be expended by users in obtaining natural resources data/information.

At the present time, although specialized systems are being developed within the State, the mechanism does not exist in Missouri to link, in common network, the sources and users of natural resources data/information. The greatest present need is for a comprehensive system to weld together the capability that already exists.

GENERAL CONCEPTS

The Natural Resources Information System is not a "system" in conventional systems engineering language. As defined herein, it refers to a service mechanism for the (1) assembling of sensed, monitored, measured, and collected data which may be maintained in both machine processable and non-machine processable forms; (2) processing this raw data into physically meaningful data; (3) adjusting and organizing processed data into forms and formats suited to modern storage, retrieval, and manipulative procedures; (4) storing this data in a systemized manner as in information base; (5) disseminating data from this base of information; and (6) manipulating and processing this data into graphs, models, study plans, specifications, and simulative systems needed to manage natural resources, as may be determined necessary by user requirements.

Basic to the successful implementation and operation of any large-scale information system are three critical elements: (1) the users of the system, (2) the information base, and (3) the information services. In order to better define the NRIS scope, these three important areas are covered individually below.

NRIS USERS

The NRIS must be designed to serve the intended users, i.e., the decision maker, the planner, the technician, the researcher as well as the public in general. The starting point in detailed design then is to identify the needs of

the users. As envisioned, the Missouri NRIS would ultimately serve the natural resource information needs of various governmental levels as well as the general public. The involvement of these users will no doubt evolve as the NRIS expands and develops.

NRIS INFORMATION BASE

The heart of the Natural Resources Information System is the NRIS Information Base, which will be designed to meet the needs of the user agencies for information. The Information Base contains the organized "information" collected and dispersed within the system. Though comprehensive in nature, and systematically organized along defined structurally similar lines, the Information Base need not be centralized. Each agency can, and generally should, maintain its own information files needed to fulfill its particular function or functions. The NRIS Information Base will exist in both machine-processable form (computer cards, tapes, disks, etc.) and non-machine processable form (published material, maps, imagery, microfilm, etc.).

The Information Base should be organized by categories and subcategories, and include information on all relevant and related resources.

The categories as shown in the data system catalog have evolved from the NRIS identification activity and represent a present "definition" of the NRIS Information Base.

The NRIS Information Base will be implemented using certain standard codes and procedures designed for ease of use and system compatibility. The Information Base would remain "open ended" in structure in order to accommodate new data and information. Some data in the Information Base may have certain restrictions on its release to NRIS users. In these cases, the requestor would be notified by NRIS to contact the NRIS data-source agency to specifically re-

quest release of this data. In this manner, security and any other release restrictions established by the data-source agency would be safeguarded. To the fullest extent possible, the NRIS Information Base should be made compatible with existing and planned state and federal systems.

NRIS SERVICES

From the NRIS Information Base, various services would be available to NRIS users. NRIS services would include providing information on data availability, providing basic data and information retrieval, and providing various data analysis capabilities. These services should be available to users requesting them through letter and telephone contacts, and also through remote computer terminal access.

Catalogs and indexes, in both machine processable form and non-processable form, would be readily accessible for determining availability and location of data and information. This service would include providing printed and computer aids to determine NRIS Information Base contents and location, form and format of data available, periods of record, station location networks, etc. These services would provide initial information to users and would provide the basis for users to easily use other NRIS services.

Other NRIS services would include access to and retrieval of data and information from the NRIS Information Base. The data/information requested could in many instances be provided to the user in a variety of forms and formats as desired. These include computer generated reports, microfilm products, published reports, computer cards, and tapes. As mentioned earlier, these services would be available in response to telephone, letter, and personal contacts as well as through the usage of various computer terminal capabilities.

Various analysis capabilities would also be an integral part of NRIS services.

A computer library of statistical packages and analysis models would be available. Providing data and information to users in the form of computer generated plots, charts, and maps would also be important. These services would be supported by digital plotters, digitizing equipment, and interactive graphics equipment. Services would be available for the analysis and reproduction of certain micro-filmed and published information. Light tables, transfer equipment, etc. would be available to provide analysis capabilities with respect to remotely sensed information. Various important management level reports would also ultimately be available from the system. These analyses services would be an important part of the NRIS operation in order to provide requested data and information in the most useful and meaningful forms possible.

NRIS ORGANIZATION

General

Having defined the scope of the NRIS, the next step is to delineate a set of feasible alternative approaches for organization. Considerable difficulty is encountered in attempting to define alternative approaches. Organizational functions interface so completely with those of acquisition, user service, and management that it is impossible to design an organization independently. The alternative is to postulate a set of total system configurations and to describe the functions within each. Three approaches will be described in some detail.

Linked Network Approach

The linked network approach consists of many NRIS centers linked together by a communication network and management structure. Although individual centers would differ from each other because of their emphasis, the functions of acquisition, indexing, cataloging, reproduction, archiving, retrieving,

referral, and dissemination would be performed within the network. However, the functions of analysis and interpretation would not be performed by network centers. The linked network users would need to be sophisticated enough to analyze their own needs and synthesize the desired information from the data they receive. In one sense, each center is a referral agency. That is, to the extent that the center can service a request, it will do so. However, uninformed users would be referred to proper facilities to process requests. Since all centers are housed in some existing agency, the only management structure to be suggested concerns the network operations. The directors of the participating departments or the NRIS committee could establish policy and guidelines for the network. Although the linked approach in its minimal form is only a small modification in the structure of department level systems, its value to a new community of users has proven to be very high. Since the existing entry for a user from the public domain is into an archive, only those requests by proper index terms can be serviced efficiently. However, by adding user oriented centers which are linked into the network, less precise requests could be serviced.

An Hierarchical Organization

The Natural Resources Information System can be portrayed as an hierarchical network in which each center can be seen from both a function and organization viewpoint. The operation of such a system will be discussed below.

A user enters the system at a nearby entry point. These points can be called Access Centers. The request is analyzed, formalized, and processed. The system may respond, subject to any prescribed security provisions, by disseminating to the user a list of information sources for the user to contact, a list of

documents for the user, a set of documents for the user to read, physical samples or raw data for the user to analyze, a set of displays showing the results of the system analyzing the data on behalf of the user, a list of algorithms (or even the computer programs themselves) to do some analysis of raw data, or combinations of these. The products, usually given out at the entry point, can be documents, physical samples, imagery data, or raw data. Moreover, provisions for mail or communication of output to the user by mail, etc., can be made.

The control of the system would be based at a central focal point called an Analysis Center. Here the data acquisition and processing functions will be located and/or monitored. The central focal point is the Analysis Center surrounded by Access Centers. This is an hierarchical network structure. More levels can be added if deemed necessary.

Each center would be specialized in scope, with the degree of specialization increasing as one goes down the hierarchy. Thus the size of the data base stored in the center and the number of various services on the premises decrease with the hierarchical level.

Management is an important segment of the hierarchy. The specific plan of organization and authority would have to be worked out properly. A primary issue would be the degree of autonomy each level in the hierarchy has over its own affairs. Another issue would be the funding arrangements for the system.

The system would be set up initially using a decentralized format. The Analysis Center would generate data indexes. Existing systems would do some analysis and one could serve as the Access Center. The system would evolve eventually into a full-scale hierarchical information network.

Single Agency Approach

An operational Single Agency Natural Resources Information System would consist of three major subsystems: --(1) a data acquisition subsystem, (2) a data handling subsystem, and (3) an administration subsystem. These three subsystems would be housed in a single agency center.

The data handling subsystem would perform three main functions: (1) data collection, (2) data processing and storage, and (3) data distribution.

The Single Agency NRIS would perform the following functions:

- Initially processing all data received, including recording, annotating cataloging, and indexing
- Reproducing data for storage, analysis, and further processing
- Further processing, including image enhancement, rectification, digitizing, and gridding
- Maintaining and administering a Working Data Bank; that is, a point at which those data with high utilization potential are deposited
- Maintaining and administering a Permanent Data Bank; that is, a depository for all data received into the system
- Providing any special processing requested by users
- Coordinating the components of the system

The Single Agency NRIS would handle user requests and distribute data to users.

The Single Agency NRIS management subsystem would consist of an administration which would be the hub of the entire system and house the collection, processing and user service centers. The organization could be a completely new agency or a designated existing agency.

Although this description differs markedly from that which would perhaps

evolve from the present effort, it is worthwhile to establish the salient features of the Single Agency NRIS in the event this type of system were elected.

- It would be a new agency or a designated existing agency.
- It would be a highly centralized system, with the major operations housed in a single center.
- There would exist an assortment of well organized, highly capable data sources.
- There would exist a highly capable processing technology.
- There would be a small, elite community of users, so that the system would be rather passive in interfacing with a wide variety of users.

RECOMMENDED NRIS ORGANIZATION

Careful study has been made of the advantages and disadvantages of the three organizational approaches mentioned above by various state and federal agencies. Extensive design work has been done at the federal level by the U.S. Geological Survey in development of the National Water Data Exchange System (NAWDEX). The NAWDEX organizational concept is actually a combination of the linked network approach and the hierarchical approach where all participating agencies make up the linked network and a "Systems Central" provides a coordinating point of contact and gives this approach its hierarchy. It is recommended that this approach be taken for the development of a Missouri Natural Resources Information System.

COMBINED LINKED NETWORK AND HIERARCHICAL APPROACH

As the name implies, the combined linked network and hierarchical approach is organized as a network, within a defined hierarchy.

The process of acquiring natural resources data from original sources would not be significantly different in this approach than it is at present, allowing for normal growth in technological capability. The data collection functions would be coordinated through the ICNRI, but would remain the responsibility of those agencies with expertise in the appropriate areas. Regardless of who collects the data, the important factors are:

- Make the data available to users, consistent with cost and efficiency, rather than just to the source agency.
- Minimize redundant data collection programs through intensified coordination.

Storage of all natural resources data and information in a centralized location is not the objective of this approach. However, a centralized facility is made available to those cooperating agencies not wishing to internally develop the necessary storage, processing, and retrieval capabilities. This centralized facility is also available to store certain duplicate files for cooperating agencies.

The basic concept behind a system of the NAWDEX type is that the large users (agencies) maintain internal data storage and retrieval systems for data which they collect and use. A "Systems Central" also provides the computer services for the smaller agencies and is the processing site for external requests to the information system. Obviously, a high degree of interagency coordination and standardization of data formats is necessary to make a system of this type function properly.

In addition to the data storage and retrieval function, "Systems Central" would maintain an accurate and complete index of natural resources data in the

files of the participating agencies. This index would have sufficient detail so that the location, character, form, and availability of the data in the files of each participating agency can be determined therefrom. Additional details on this organizational approach are included in the following section.

ORGANIZATIONAL RESPONSIBILITIES

As envisioned in this approach, specific organizational responsibilities fall into three main categories:

- (1) Overall administrative level direction;
- (2) NRIS committee level direction; and
- (3) Implementation and operation.

OVERALL ADMINISTRATIVE LEVEL DIRECTION

The ICNRI would continue to provide overall direction of the NRIS effort. Activities would possibly include certain policy formulation, communication of system objectives, action of committee level recommendations, and coordinate funding requests. Hopefully, the ICNRI would help insure that the NRIS was the focal point for resource information needs of other Council working groups and activities, i.e., remote sensing, land resource management, and other resource related efforts. An important ongoing responsibility of the ICNRI will be for each department director to help insure responsive participation of other staff members in his department in NRIS implementation and operation. This would also include careful attention to department representation on and participation in the work of the NRIS committee. Only with this commitment of ICNRI support can the NRIS succeed.

COMMITTEE LEVEL DIRECTION

The NRIS committee under the direction of ICNRI would provide the "working level" direction to NRIS implementation and operation. This would include implementation scheduling, development of operational guidelines, prioritizing implementation activities, and recommendations on staffing, funding, etc., all within ICNRI guidance. Needed subcommittees and working groups would be established to accommodate certain areas of specialization and mutual interest, i.e., a working group of four to five agencies might consider implementation questions regarding the geologic and land resources area of the NRIS, etc. The NRIS committee would provide general guidance to the NRIS implementation and operation staff and through each agency committee representative help insure full participation by each respective agency.

IMPLEMENTATION AND OPERATION

The implementation and operational responsibilities would be coordinated by NRIS "Systems Central" staff with assistance from technical support staff eventually in each of the NRIS agencies. The functions and responsibilities of these two groups are described below.

NRIS "Systems Central" provides the coordinated implementation direction and serves as the primary point of contact for system operation. "Systems Central" staff would accommodate the coordinated analysis, design, and implementation of evolving NRIS capabilities which would include provisions for new data and information as well as extending and enhancing existing capabilities. "Systems Central" would also carry out the repetitive functions associated with day-to-day operations of the NRIS. These activities would include receiving and interpreting requests; routing requests to the proper entity as necessary; pro-

cessing requests for data and information; communicating with agency technical support staff to insure coordination of responses to users; processing NRIS utilization and accounting information; monitoring file updates and indexes; and maintaining communication with NRIS users. Related responsibilities would include the development of standards, user manuals, documentation, request forms, and other procedures.

The technical support staff, eventually in each NRIS agency, would provide the necessary interface with NRIS "Systems Central" for system implementation and operation. This would include analysis, design, and other technical support related to each agency's inventories and other development work toward system implementation. The technical support staff would work with "Systems Central" in receiving, forwarding, processing, and tracking user requests in an operational mode.

Successful NRIS implementation using this approach requires a close, well coordinated working relationship between "Systems Central" and the technical support staff in order to insure cohesive system implementation and responsive system operation.

NRIS-NAWDEX CONCEPT

Listed below is a general description of this approach:

1. NRIS agencies continue to maintain data entry, verification, storage, and retrieval systems for data which they collect and use.
2. Requests for information may come from two sources, these being NRIS agencies and other requesters.
3. Requests for information may come to two sources, these being NRIS agencies and NRIS "Systems Central".

4. Requests which cannot be satisfied through the file holdings of a particular NRIS agency will be coordinated through "Systems Central" (via computer terminal, mail telephone, etc.).
5. "Systems Central" will process requests through its file holdings (see 6 below) or will interact with other appropriate NRIS agencies to satisfy the request.
6. "Systems Central" file holdings will include appropriate copies of selected NRIS files; accompanying computer retrieval and analysis software for these files will also be available. The basis for selecting these NRIS files will be a mutually recognized need for extensive interagency utility of certain files and the need to provide integrated data bases.

NRIS REQUEST RESPONSE SITUATIONS

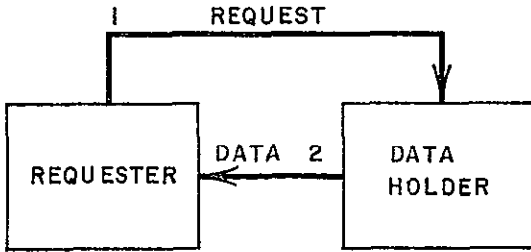

DIRECT RETRIEVAL

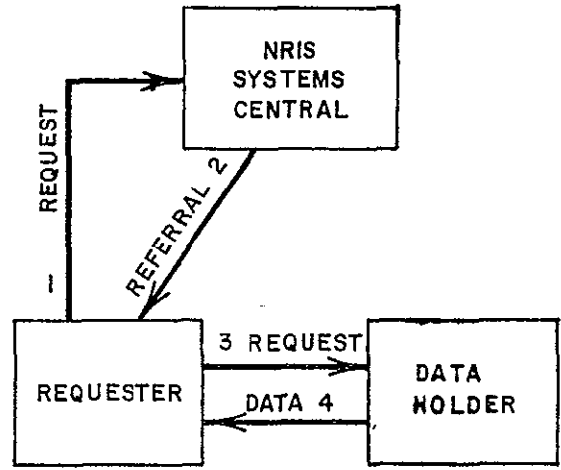

DIRECT RETRIEVAL BASED ON REFERRAL

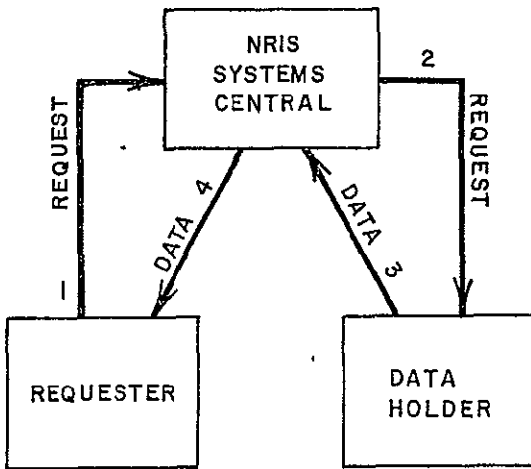

RETRIEVAL THROUGH SYSTEMS CENTRAL

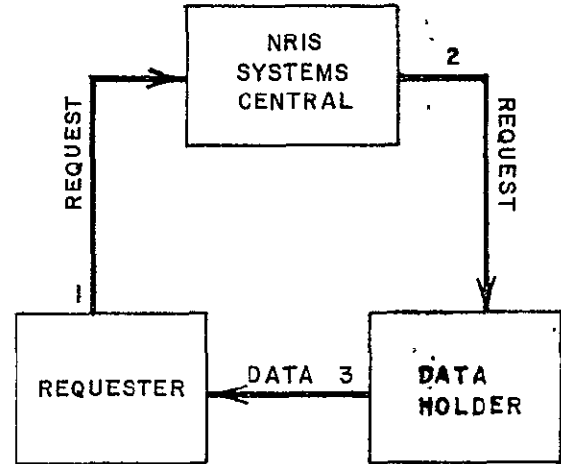

DIRECT RETRIEVAL AT SYSTEMS CENTRAL'S REQUEST

MISSOURI NATURAL RESOURCES INFORMATION SYSTEM

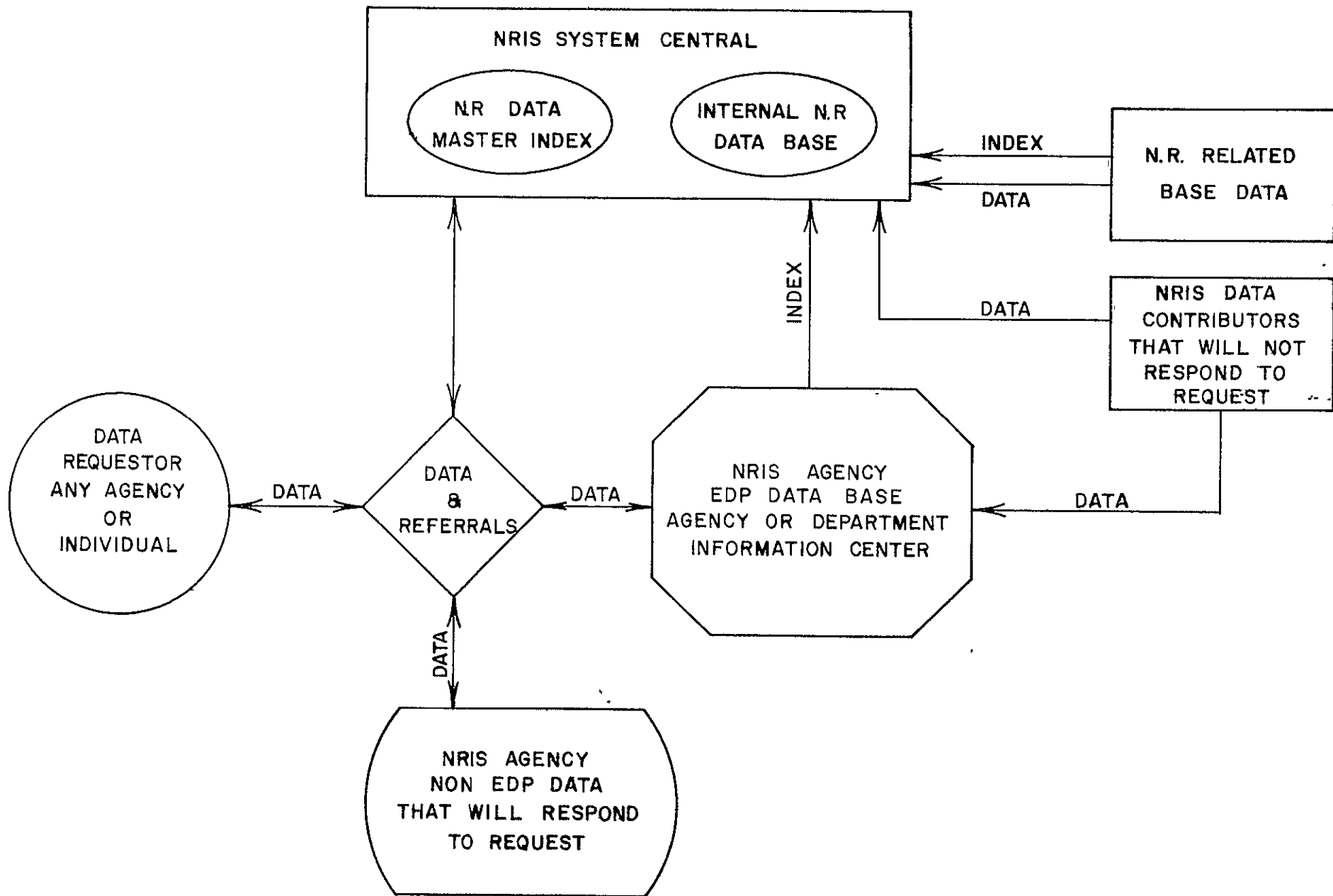

COST ANALYSIS OF
NATURAL RESOURCES INFORMATION SYSTEMS

SINGLE AGENCY - NRIS

Location:

In this approach a single agency would take over all operations on the NRIS. The agency would be a new one created for this specific purpose and would be located within one of the Divisions. All data base work as well as special products and other products would come from this agency. It would be difficult to select the department.

Equipment:

This agency would require a large computer system and staff. Special equipment would be necessary to store and distribute EDP data.

Personnel:

Agency Director
Programming Manager
Computer Operations Manager
3 Computer Operators
5 Systems Analysts
12 Programmers
6 Data Entry
5 Clerk Typist
Remote Sensing Specialist

Funding Per Year:

Computer Hardware	\$ 630,000
Personnel	435,400
Other Expenses and Supplies	143,700
TOTAL.....	<u>\$1,209,100</u>

LINKED NETWORK - NRIS

Location:

In the linked network approach, the system is a completely decentralized one. The system actually resides within each of the departments. The only external function is the management group. The Department of Natural Resources, Department of Conservation, Office of Administration, etc., would be expected to provide all services.

Equipment:

The equipment needed by each department would be a direct function of the type and amount of data maintained by the department. The minimum EDP equipment would be a mini-computer system with line printer, card reader, disk drive, and tape drive. Many departments also maintain large amounts of available data in non-EDP formats. This requires those department to have publishing and reproduction facilities.

Personnel:

Data Base Manager
Systems Analyst
2 Operators
Programmer
3 Data Entry
2 Clerk Typist

Funding Per Year: (for each department)

Computer Hardware	\$ 63,000
Personnel	110,000
Other Expenses and Supplies	<u>36,000</u>
TOTAL.....	\$209,000

Assuming six departments in the network--

6 x \$209,000 =	\$1,254,000
One remote sensing unit =	<u>30,000</u>
TOTAL..... =	\$1,284,000

HIERARCHICAL ORGANIZED - NRIS

Location:

In this approach the departments would be given the responsibility to collect and format the information. This data would be delivered to the Analysis Center for data acquisition and processing. The Analysis Center would be located in one of the departments. Each department would serve as an Access Center to submit requests to the Analysis Center.

Equipment:

This system would require a large computer for the Analysis Center. The departments would need appropriate data entry equipment and equipment to produce the initial material that is not EDP formatted.

Personnel:

In each department we would have:

- 1 Systems Analyst
- 1 Data Entry Person
- 1 Clerk Typist

The Analysis Center would have:

- Programming Manager
- Computer Operations Manager
- 3 Computer Operators
- 3 Systems Analyst
- 12 Programmers
- 4 Clerk Typists
- 1 Remote Sensing Specialist

Funding Per Year:

Computer Hardware	\$630,000	
Personnel	330,600	
Other Expenses	<u>110,000</u>	
	\$1,070,600	\$1,070,600

Cost for Each Department:

Terminal	5,000
Personnel	31,000
Other Expenses	<u>10,200</u>
	\$46,200

Cost for 5 Departments	(46,200 x 5)	<u>231,000</u>
	TOTAL.....	\$1,301,600

RECOMMENDED NRIS

Location:

In this plan each department will have its own computing capacity. This capacity would include data entry, retrieval and analysis. The level of analysis will be limited by the devices and capacity of the department hardware. Each department will also have responsibility for distribution of non-EDP data. In addition, one of the department centers will be selected as System Central. This department will have the expanded capacity necessary for special analysis and overall indexing of data sources.

Equipment:

The department centers will be of mini-computer size as in the Linked System. The System Central will be expanded to include a somewhat larger system than the mini-computer, but less than the large system. The System Central will also obtain special purpose devices.

Personnel:

<u>Department</u>	<u>System Central Staff</u>
1 Systems Analyst	1 Computer Manager
2 Operators	3 Systems Analysts
1 Programmers	2 Programmers
3 Data Entry	3 Data Entry
2 Clerk Typist	4 Clerk Typists
	1 Remote Sensing
	2 Operators

Funding Per Year:

<u>System Central:</u>		
Computer Hardware	\$157,500	
Personnel	183,800	
Other Expense	60,600	
	<u>\$401,900</u>	\$401,900
<u>Department Cost:</u>		
Computer Hardware	63,000	
Personnel	90,200	
Other Expense	30,000	
	<u>\$183,200</u>	
Cost for 5 Departments		<u>732,800</u>
TOTAL.....		\$1,134,700

SUMMARY:

The following basic assumptions have been made in the foregoing analysis:

- 1) That no systems are available at this time;
- 2) That the system will be used entirely for the NRIS;
- 3) The system would be in the fully developed and implemented stage of operation.

All three of the assumptions are true only in varying degrees. These variations will have a great effect on overall cost that cannot be anticipated at this time.

PROPOSED PLAN FOR ELECTRONIC DATA PROCESSING
ACTIVITIES WITHIN THE DEPARTMENT OF NATURAL RESOURCES

The Department of Natural Resources is the manager of the natural resources of the State of Missouri. In general terms, the manager's task is threefold: 1) to insure that budgeted resources are not exceeded by actual expenditures; 2) to meet delivery commitments; and 3) in the event of anticipated failure to meet resource or time commitments, to give early warning. These tasks apply throughout the Department, from department to project level. Each manager must have timely information at his disposal in order to fulfill his task. This information ranges all the way from fiscal information to detailed technical data.

Currently most of the information used within the department is gathered and disseminated by manual methods. In many instances this is the most practical and economical method; but there are also instances where EDP could be employed to a great advantage.

A list of potential programs for a DNR EDP system was developed in February of 1977. The implementation of this system and the development of these programs is dependent upon three factors: 1) the acquisition of a computer main frame; 2) the acquisition of computer personnel (EDP System Analyst, programmers, and data entry person); and 3) department level coordination of program development.

The purpose of this report is to explore potential solutions and to make a recommendation for a DNR EDP system.

Main Frame Hardware

The Division of EDP Coordination in the Office of Administration has until very recently planned the establishment of six large host centers in state government. These host centers would serve only the hardware need of all

departments. The Office of Administration/Revenue system is the host center designated to the Department of Natural Resources. This center is still in the development stage. It does not currently exist and will be at least one year in development. It is hoped that sometime in the future, probably within the next two to three years, there will be a limited amount of use of the Office of Administration/Revenue Computer Center. The use of this equipment would be limited to either time sharing or Remote Job Entry (RJE) input. It is our understanding that the Division of Environmental Quality and the Division of Administrative Services use this center to a limited amount at the present time.

Presently, the University of Missouri-Rolla (UMR) serves as a host center for all work conducted by the Division of Geology and Land Survey. UMR has IBM hardware like that in the Office of Administration and proposed office of Administration/Revenue system. Currently the University of Missouri-Rolla also operates on a RJE mode to an IBM 370/158 in Columbia and operates a 360 Model 50 at its campus in Rolla. There is no means of time sharing or interactive work through the University system and possibly no potential for that utilization. It is our understanding in discussions with University personnel that there is available to the Department of Natural Resources approximately 50 hours of computer time per week, an amount of time well in excess of any potential use of the computer in the foreseeable future. Charges for the use of this computer facility are shown on the enclosed supplement, page 52.

The U. S. Geological Survey Mid-Continent Mapping Center located in Rolla has a computer capability comparable to the University of Missouri-Rolla. The system installed in Rolla is a SEL-86. The SEL-86 system is currently underutilized by USGS personnel in Rolla. It has been suggested by USGS that the Division of Geology and Land Survey could utilize some of this computer power.

The SEL-86 is also operating as a RJE terminal to several of the national data systems developed within the Department of Interior. These systems would include the water oriented data bases and the cartographic information center. This access could also be a resource to the Department of Natural Resources.

Programming and Computer Staffing

Efficient operation of any computer system requires the expenditure of man hours for development of computer programs, maintenance of the programs already written, and the maintenance of the hardware. Currently within the Department of Natural Resources there is a very limited pool of programmers and computer personnel. The Division of Géology and Land Survey has on its staff one EDP Systems Analyst and it is our understanding that the Office of Administration will be employing a similar position very shortly.

Approximately one programmer will be required for the maintenance of each fifty programs being used by the Department. This person can be an EDP Systems Analyst located in the Division to run the program. Most computer programs are not static, but dynamic, and do need change throughout their operation. It is important that this person have direct access to those persons using the programs. The placing of this maintenance function in the host center or at the computer has proven to be very ineffective.

The second type of programming person needed is the programmer who initially develops the program. Much of this work is pure programming labor. The conceptual design--detailing the input items, the calculations to be made, and the output format of the data--should be prepared by the user and EDP System Analyst at division or program level. The programmer can take this design and write the

actual computer program. As soon as this initial program is written, debugged and in operation, the control of programming is turned over to the EDP Systems Analyst for maintenance. There are no staff positions for programmers in the Department at this time. Consequently, programming will have to be done by outside contracts. Two sources of programmers exist--one through service centers or consultants such as McDonnell Douglas, and the other through the University system. The experience with the University of Missouri-Rolla in program development has been very good. The University Computer Center can provide some programming at \$12.00 per hour. In addition, programming can be obtained through part time employment of computer science students (see Supplement 1, Page 52).

Data Links

Of primary importance to the user is the method in which the data is entered into the system and the method in which the data is returned to the user. Two primary methods of entering the data are available. First we have the normal key punched and verified cards. They are entered into the computer through a card reader. This card reader can be located at the computer, or the card reader can be in a remote location such as the Division office. In the latter case, the system would be a remote entry type or "RJE". The second entry type format would be one of direct access to the computer itself. This on-line time sharing or interactive system would allow a person to enter data directly into the computer from a keyboard or teletype printer. A computer would respond immediately to any queries or actions requested by the operators. This type of operation is primarily used in data base management and special computing situations. Large volumes of input and output are generally not associated with time sharing.

Data transmission to the computer through remote job entry terminals may require fairly high grade communication lines. These communication lines are usually of a better grade than regular voice telephone lines and must be leased for this purpose. Teletype terminals are generally of such speed that normal phone grade lines are sufficient. Paper tapes and floppy disks can be used to increase transmission speeds still within the limits of the normal voice grade line.

Combinations of terminals can be obtained. An example of this would be an intelligent terminal. The intelligent terminal actually is a small computer that accepts data from a keyboard, checks for certain types of error and stores the data on a floppy disk or sends the data to the computer. The Division of Geology and Land Survey is currently requesting proposals for such a terminal for use in accessing the National Coal Data Bank. The intelligent terminal has the advantage that all data is displayed on a CRT screen as it is being entered into the floppy disk. The operator then can verify what she is typing as she goes. In addition, the terminal will have built into it software that checks the data for some types of errors. This type of system then does not need further verification as must be done with a key punch. The data can be then taken from the floppy disk and entered in the computer for processing.

RECOMMENDED PLAN FOR DEPARTMENT OF NATURAL RESOURCES

Recommendation No. 1

A Department of Natural Resources EDP Systems Committee be established. This committee would be composed of one representative from each program having EDP applications and the EDP Systems Analyst from each Division. The committee

would be chaired by the Director of Administrative Services. It would be the function of this committee to oversee the development of the EDP system for the Department of Natural Resources and to establish priority and funding allocations for these applications, as shown in Figure 1, Page 53. This committee would serve as the guiding body for the EDP system development staff at Rolla.

Recommendation No. 2

One of the first decisions that must be made is the selection of the main frame computer. In FY 78 there appears to be few alternatives in the selection of a main frame. Presently the University of Missouri-Rolla can provide the hardware and CPU's to adequately meet the needs of the Department of Natural Resources. It is recommended that the University of Missouri-Rolla Computer Center be designated as the host center for the Department of Natural Resources. It is further recommended that a contract be established with the University to allow for programming, key punching, verification and CPU time. The contract would be in the form shown as Supplement 2, pages 54 and 55 (Contract of Division of Geology and Land Survey).

Recommendation No. 3

A Department of Natural Resources EDP development staff at Rolla be established. This development staff would consist of one EDP Systems Analyst and one full time Clerk Typist.

Recommendation No. 4

The DNR EDP Systems Committee select an appropriate number of systems to be developed for FY 78 and proceed with the development of these systems through the Rolla development staff and the University of Missouri-Rolla. In addition, the

committee should provide for the execution of existing EDP applications through the EDP systems development staff in Rolla.

Recommendation No. 5

Each Division in DNR should employ an EDP Systems Analyst to develop EDP program requirements for the Division and serve as the contact point with the Rolla development staff and the University of Missouri-Rolla. After the programs have been developed the Division EDP Systems Analyst will maintain any existing programs and supervise their execution.

Recommendation No. 6

Key punch and verifier equipment be obtained by the Division of Administrative Services and the Division of Environmental Quality. All data to be submitted to the computer center in Rolla should be submitted in card form for further processing; and all results of computations should be mailed back or delivered to all divisions in printout form.

Recommendation No. 7

The EDP Systems Committee review and upgrade the EDP program for FY 79 and 80.

BASIC PLAN FOR FISCAL YEAR 1979

The following modifications would be undertaken in Fiscal Year 79: Two additional EDP Systems Analysts would be added to the staff. These analysts would be in responsible charge of the maintenance of existing EDP systems. Development of new programs would continue as in Fiscal Year 78. Request would be made by the Department of Natural Resources for four intelligent terminals; one to be

located at Rolla, one at the Division of Administrative Services, one at the Division of Parks and Recreation, and one in the Division of Environmental Quality. These terminals would be connected over voice grade lines so that data could be transferred between any two systems. Data in the three Jefferson City terminals could be entered into floppy disks and the floppy disks would be transferred to the University of Missouri-Rolla Computer Center for execution. The output data would be in the form of a high speed line printer and would be returned along with the floppy disk to the user division. Small quantities of data would be transmitted terminal to terminal.

During FY 79, the possibility should be explored of changing the host center from the University of Missouri-Rolla to the Office of Administration/Revenue System.

NATURAL RESOURCES INFORMATION SYSTEM

The proposed conceptual design of a natural resources information system is a decentralized, linked information sharing system. At the present time almost all the data to be shared by the various departments is in cartographic or manuscript format. The conceptual design envisions that as the computer capabilities of individual departments develop, certain data which can be shared between departments will be available in digital format. At that time the Natural Resources Information System would begin the utilization of these files for sharing information. In other words, the first step in the development of a computerized natural resources information system will be development of the individual computer capabilities of the departments.

Some have suggested that the Natural Resources Information System could be housed in one computer of its own, thus distributing information to the various

agencies. However this super computer, or statewide computer network, would be extremely expensive and require a great deal of effort on the part of the individual departments and is not the recommended plan in the conceptual design. The conceptual design does envision a coordinating staff called a Systems Central. This staff would be responsible for indexing the various data items available to the requestor. Systems Central would also have the function of referring requests to the appropriate agency for their response. A long range goal of the Systems Central staff would be the development of certain types of data and peripheral systems which could be used and shared by all members of the Natural Resources Information System.

The foregoing recommendations for the Department of Natural Resources' electronic data processing activities envision the development of the basic data files that would be necessary for a natural resources information system. It would also provide for access to the data files in other departments and Federal agencies. It is for this reason that we recommend, in order to establish a much needed natural resources information system, that the first link of developing a Department of Natural Resources' EDP system be established.

CHARGES FOR COMPUTING SERVICES, UMR COMPUTER CENTER, ROLLA, MISSOURI
Telephone 314-341-4841

The following charges are per hour (except as noted) and include an operator and all supplies in the case of equipment usage.

EFFECTIVE JULY 1, 1976

SERVICE	PRIORITY	
	NORMAL ^o	HIGH*
360/50 CPU time/hr	90.00	126.00
1403 printer - per page	.01 per page	.02 per page
2540 card reader	.10/100	.15/100
2540 card punch	.30/100	.35/100
129 card punch, verify	5.40	6.60
029 interpreter	5.40	6.60
Graphics Systems and Calcomp plotter	18.00	24.00
Data Control and Program Monitoring	8.00	10.00
Programming and Analysis	12.00	15.00
Consultation and Systems Design	18.00	23.00
Versatec plot/printer	.10 per linear foot	.15 per linear foot

The statements for Computer Center services are prepared and sent to the departments the last week of each month. The statements are prepared by an accounting program which has recorded the time used for various services. If the time recorded for processing a program seems excessive because of possible equipment malfunction or operator error, the Computer Center should be informed within three days after the service is performed. It is much more difficult to make corrections after the statements have been prepared and sent to the Business Office.

^oNORMAL: Turn-around time will depend upon work load with most jobs processed on a first in - first out basis. In order to maintain efficiency it may be necessary to class some jobs.

*HIGH: Will have priority over all other classes of work (except maintenance and down-time). Work will usually be initiated within an hour after receipt.

<u>ITEM</u>	<u>RATE PER MONTH</u>
IBM 2316 Disk Pack	20.00
Reel of magnetic tape (2400 ft)	2.50
Reel of magnetic tape (1200 ft)	2.00
Reel of magnetic tape (600 ft)	1.75

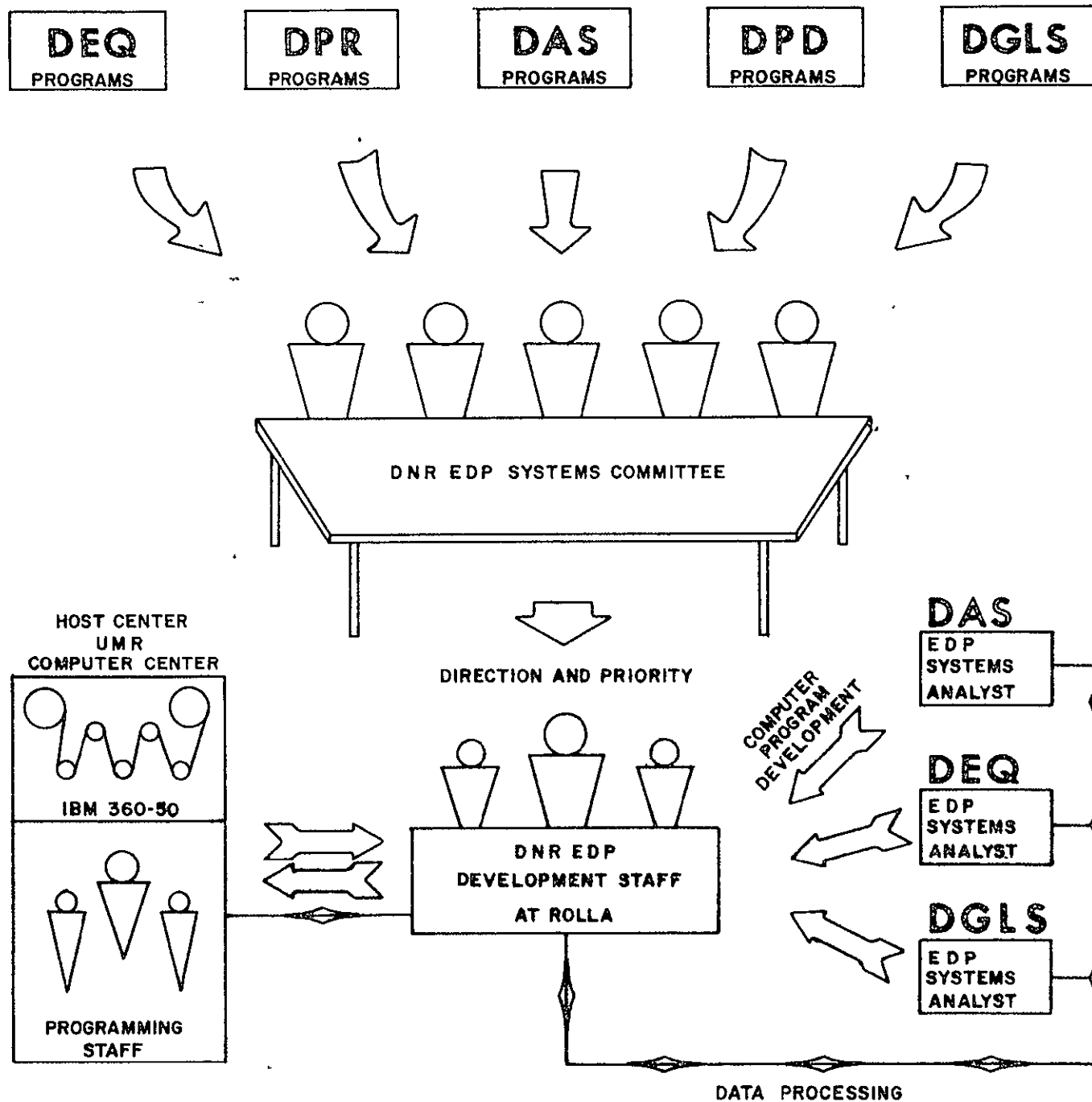

Figure 1

1 Instructions for preparing form 1 Type with maximum pressure, you are making 7 copies. 2 Originator must not use shaded area 3 Each form is to contain only one related commodity group. 4 Actual description only to be typed in description area, no other comments	2 Account Number Appropriation Class	3 Recommended Vendor and Remarks <i>Land Survey</i> 31-31/31	

4 Requisitioned By Natural Resources	5 Delivery Required	6 Agency Approval Date/Phone No. <i>7/1/77</i>	7 Requisition Number 8795-8-8931
--	----------------------------	--	--

8. REQUISITION/PURCHASE ORDER OFFICE OF ADMINISTRATION Division of Purchasing State Capitol Building P. O. Box 809 Jefferson City, Missouri 65101	9 SHIP TO (FOB Destination) (See Block 14 below for invoicing instructions) Department of Natural Resources Div. of Geology & Land Survey Rolla, MO 65401	10 Purchase Order Number C29499
		11 Purchase Order Date 7-26-77
		12. Page 1 of <u>2</u>

13. Vendor and Vendor Code No. University of Missouri - Rolla Computer Center Rolla, MO 65401 05077923	14 INVOICING INSTRUCTIONS Send original and three copies of all invoices to the following address Same as in block 9
---	--

Invoice only items shipped Invoice back-ordered items when delivered

15 Bid No. _____ This order is subject to the Terms and Conditions of the referenced Invitation for Bid as well as those attached to this Purchase Order	16 Terms _____ % _____ days	17 _____
---	------------------------------------	-----------------

18. Item No.	19. Description of Materials or Services	20. Estimated Costs	21. Quantity Accepted	22. Quantity Unit	23. Unit Price	24. Amount
1.	Contract Period: 7/1/77 thru 6/30/78. Contract agreement in connection with various Computer Services through period June 30, 1978, as outlined below: a. Adjustment of surveying networks, surveying calculations, computer index of all state land surveys and all state corners. b. Data base of curves in the state and a analysis of chemical components of coal and coal ash. c. Basic cost accounting, time accounting and other project management aspects. d. Developing a catalog of natural resources data and testing a mini-computer data base management system. e. Miscellaneous other federal contracts which may require computer applications.					
Estimated TOTAL: \$12,869.00						

JUL 29 1977
 MO. GEOL. SURVEY

ORIGINAL PAGE IS OF POOR QUALITY

ORIGINAL PAGE IS OF POOR QUALITY

When shipment is received, indicate the quantity received in the "Quantity Accepted" column. Indicate in the "Remarks" section whether the shipment is "Complete", "Partial" or "Final". Report any damage to the equipment by item number, quantity and type of damage or loss in the "Remarks" section.

Received by *Sally Taylor* Date *7/20*
James Moore

1 Requisition Number R795-8-8931		2 REQUISITION/PURCHASE ORDER			3 Date 7/1/77		4 Page <u>2</u> Of <u>2</u>		
5 Item No	6 Description of Materials or Services	7 Estimated Cost	8 Quantity Accepted	9 Quantity/Unit	10 Unit Price	11 Amount			
	12 Budget Code								
	<p>"The State of Missouri is not obligated for expenditures under this contract until the funds have been encumbered against the applicable appropriation."</p>								
Approximate contract total \$12,869.00									

NATURAL RESOURCES DATA SOURCE INVENTORY

One of the basic tasks in designing a Natural Resources Data Sharing System is to determine what data is needed and to determine the source of the data. In order to make this determination a survey was undertaken to catalog data and data sources within state government. A number of questions were to be answered by this inventory. The inventory was to determine the data that was currently being used by the various state agencies. We know that data is being used, but to catalog the various data items by user is extremely important. It is also important to determine how frequently the agency uses the data. We also wanted to determine which data items could not be considered in the system design. In some instances one data item is used by many agencies. This inventory was to determine those items with high multiple use. The quantities determined by the inventory can be used in prioritization.

Many data sources are not within state government itself. Therefore it is important to determine which of the sources are within state government and to determine how we would go about prioritizing the development of that data. The system designer needs to know the coverage of the data, the timeliness of the data, and the data sharing potential. This inventory was to make some assessment of these qualities. The inventory by itself was to help in the sharing of data. The catalog was designed in order to provide a systematic approach to determine who is developing data, who is using that data, and to give the particular person's name to contact for that data. In essence then, this catalog is a true catalog of data being utilized within Missouri state government.

In previous attempts at developing needed information on data, each one of the agencies had been asked to provide a list of data items that they needed

or developed. It was found that these data items were generally not the same from agency to agency although they had the same name. Consequently, at the start of this inventory a catalog of standard data items was developed. This catalog was developed in coordination with members of the Inter-Departmental Council for Natural Resources Information. Each of the member departments were asked to list the data items which they considered to be pertinent to their work. As a result, the final catalog contains 158 data items that are meaningful. A specific questionnaire form was developed using each one of these 158 items. The form was then sent to each of the nine departments represented on the council. Each division within the department was to complete one of these forms. The inventory is therefore on a division level. For instance, in the Department of Natural Resources there are five divisions: Division of Environmental Quality, Division of Administrative Services, Division of Policy Development, Division of Parks and Recreation, and Division of Geology and Land Survey. Each of these divisions was then asked to complete one of the questionnaires. Twenty divisions finally participated in the inventory. Each of the 20 questionnaires was taken to the computer center for key punching. A computer program was written to tabulate and print the information thus obtained. In addition to information concerning the data and data sources, this questionnaire asked for the name of the key person in charge of each of the data items. This was then printed with a numerical listing giving the name of the person to whom questions about the specific data should be addressed.

The first part of the inventory is concerned with the involvement of the agency or division with the data. The agency might be strictly a collector of the data or just a user of the data; he might collect and use the data.

If the agency used the data it was asked to indicate frequency of use. The frequency of use was coded from one to six, one being data used one or more times a week, and six being unpredictable but still used if available.

The second item to be determined was what data was actually collected by the agencies. If an agency collected the data, it was asked to indicate the frequency of collection or update, the nominal area for which the data is reported, data coverage, and the primary format of the data. Each of these items was given by a numerical code. One of the intriguing items which we wanted to test was the data sharing potential of the information. There was a feeling that some of the data would not be directly available to anyone who wanted access to it. Therefore the data sharing potential of collected data was determined. The sharing potential was also given by numerical code. The codes ran from one to five and covered the range from data that could be readily used by an agency in its present format, to data not available for use to other agencies because of the confidential, complex or special nature of the data.

In order to prioritize the data use, the computer was programmed to develop a frequency of use number. This number was generated by summing the individual frequency of use code from each one of the divisions, then adding seven for each division not involved in the use of this data. A data item that is not used by any of the 20 agencies would have a frequency use number of 140. The more agencies that use the data and the more frequently they use it, the lower the frequency use number becomes. In this catalog the lowest use number was 54.

The catalog gave some very significant results. The following is a tabulation of the data most frequently used by state agencies. In this tabulation only those data items having a frequency use number of 120 or less are tabulated.

DATA MOST FREQUENTLY USED BY MISSOURI STATE AGENCIES

- 1 State Maps
- 2 County Maps
- 3 State Statutes, State Regulations
- 4 Local Project Maps
- 5 Federal Regulations
- 6 Regional Maps
- 7 Aerial Photographs
- 8 State Government Officials
- 9 County Government Officials, Precipitation
- 10 Federal Legislation
- 11 Land-Use Maps
- 12 Land Surveys, Temperature
- 13 Urban Area Maps. Transportation Maps
- 14 1:24,000 Topo Maps, Utility Maps, County Boundaries, Stream Flow Data
- 15 Soil Maps
- 16 Geologic Maps, Wind, City Government Officials
- 17 Federal-State Land Maps, Ground Water Quality, Land Ownership
- 18 Mineral-Energy Resources Map, Physical Analysis of Soil

One can see from the foregoing list that the data items could also be classed by their general usable form. The following is the data items in three groupings.

Cartographic Products

Ranking		Percent of Divisions Using the Map
1	State Maps	80
2	County Maps	75
3	Local Project Maps	50
4	Regional Maps	55
5	Aerial Photography	45
6	Land Use Maps	40
7	Land Surveys	35
8	Urban Area Maps	40
9	Transportation Maps	30
10	County Boundaries	40
11	Utility Maps	35
12	1:24,000 Topographic Maps	30
13	Soil Maps	30
14	Geologic Maps	30
15	Federal-State Ownership Maps	25

Administrative Publications

Ranking		Percent of Divisions Using the Data
1	State Regulations	55
2	State Statutes	55
3	Federal Regulations	50
4	State Officials	40
5	County Officials	40
6	Federal Legislation	40
7	City Officials	30

Data Files

Ranking		Percent of Divisions Using the Data
1	Precipitation	40
2	Temperature	35
3	Stream Flow	35
4	Wind	30
5	Ground Water Quality	25
6	Physical Analysis of Soil	25
7	Chemical Analysis of Surface Water	35
8	Springs and their Characteristics	30
9	Magnitude and Frequency of Missouri Floods	20

The final conclusions from any survey or inventory must be considered in the context of the inventory methods. This inventory points up a need for more indepth study in some areas. Nevertheless, we can draw some general conclusions.

Map products must be given a very high priority in the development of any natural resources data sharing system. The county map produced by the Missouri Highway Department is very highly used. Special emphasis should be given to the development of this map to a metric scale.

One can also conclude that aerial photography plays an important part in the day to-day operations of these state agencies. Remote sensing products and orthophoto maps seem to play a very small role. It may be correct to presume that these products would be used if available and understood. This presumption would be based upon the premise that they are so similar in application and use to aerial photos. The need for additional demonstration projects and training in remote sensing is indicated.

This catalog or inventory should be updated every few years. The natural resources data sharing system could include it as one of its projects. The information thus obtained would not only catalog the key people for specific data items, but show the trends in the use of data and trends in the collection and dissemination of the data.

SUMMARY OF DATA AND DATA SOURCES INVENTORY

Data Code	Data Name	Number of Agencies		
		Using	Collecting	Use Count
<u>CARTOGRAPHIC DATA</u>				
<u>Aerial and Space Imagery</u>				
1101	Aerial Imagery (electronic origin)	1		133
1102	Aerial Photographs	9		94
1103	Space Imagery (electronic origin)	3		126
1104	Space Photographs	2		129
<u>National Topographic Map Series</u>				
1201	1:24,000 scale	6	1	105
1202	1:62,500 scale	4		117
1203	1:100,000 scale	3		126
1204	1:250,000 scale	4		121
1205	1:1,000,000 scale	1		136
<u>Special Base Maps</u>				
1301	Local Project Maps	10	6	83
1302	Orthophoto Maps	2		128
1303	Urban Area Maps	8	1	104
1304	County Maps	15	1	66
1305	Regional Maps	11	2	91
1306	State Maps	16	2	54
1307	Satellite Image Maps	2		129
<u>Earth Resources Maps</u>				
1401	Geophysical Maps and Charts	4		122
1402	Geologic Maps	6		108
1403	Soil Maps	6		106
1404	Surficial Materials Maps	3	1	123
1405	Climate Map	5		114
1406	Hydrologic and Related Maps	5	1	115
1407	Land Form Maps	5		119
1408	Mineral and Energy Resources Maps	5	1	116
1409	Engineering Geology Maps	5	1	116

Data Code	Data Name	Number of Agencies		
		Using	Collecting	Use Count
<u>Administrative</u>				
1501	Transportation Maps	6	1	104
1502	Land-Use Maps	8	1	100
1503	Utility Maps	7	1	105
1504	Census Maps	4	1	117
1505	Federal-State Land Maps	5	2	112
1506	Congressional District Maps	4		119
1507	Tax Maps			139
1508	State, County & City Political Maps	1		129
<u>Navigation Charts</u>				
1601	Aeronautical	3		124
1602	Nautical (inland river and lake charts)	4		119
<u>Survey Records</u>				
1701	Property or Land Surveys	7	3	103
1702	Geodetic Surveys	3	1	126
1703	Engineering and Mapping Surveys	3		127
1704	State Boundaries	6	1	113
1705	County Boundaries	8	1	105
1706	City Boundaries	5	1	117
<u>Related Cartographic Data</u>				
1801	Atlases and Gazetteers	2	1	130
1802	Geographic Names	1		135
1803	Raised Relief Maps			139

Data Code	Data Name	Number of Agencies		
		Using	Collecting	Use Count
<u>METEOROLOGICAL</u>				
<u>Climatological</u>				
2101	Precipitation	8	1	97
2102	Temperature	7	1	103
2103	Wind	6	1	108
2104	Humidity	5	1	117
<u>Air Quality</u>				
2201	Gaseous & Particulate Concentrations	1	1	134
2202	Radioactivity			139
<u>Man's Activities</u>				
2301	Emission Sources	2	1	132
2302	Air Pollution Regulations and Standards	2	1	130
2303	Air Pollution Compliance Data	1		136
2304	Severe Weather Damage Data	2		130

Data Code	Data Name	Number of Agencies		
		Using	Collecting	Use Count
BIOLOGICAL RESOURCES				
<u>Wildlife</u>				
3101	Fish Inventory	3		128
3102	Wildlife Inventory	2	1	126
3103	Deer - Turkey Harvest		1	134
3104	Endangered Species	4	1	125
3105	Trapping Statistics	1	1	134
<u>Natural Vegetation</u>				
3201	Aquatic Habitat Assessment	2	1	130
3202	Wildlife Habitat Assessment	2	1	130
3203	Natural Areas Inventory	4	3	121
<u>Microorganisms</u>				
3301	Bacterial Water Quality of streams, rivers and lakes	2	1	130
<u>Man's Activities</u>				
3401	Inventory of Grass Lands	4	2	121
3402	Livestock Counts	5	2	119
3403	Inventory of Crops	5	1	119
3404	Forest Inventory	3		125
3405	Forest Protection Data	3		126
3406	Forest Products Inventory	2		131
3407	Agricultural Products Inventory	4	1	124
3408	Inventory of Irrigated Land and Products	4		123

Data Code	Data Name	Number of Agencies		
		Using	Collecting	Use Count
<u>WATER RESOURCES</u>				
<u>Surface Water</u>				
4101	Stream Flow Data	7	1	105
4102	Sediment Load	4	1	124
4103	Surface Water Temperature	3	1	125
4104	Chemical Analysis of Surface Water	7	1	114
4105	Springs and Characteristics	6	2	114
4106	Magnitude and Frequency of Missouri Floods	4		114
<u>Subsurface Water</u>				
4201	Groundwater Quality	5	1	112
4202	Chemical Analysis of Groundwater	4	1	120
4203	Observation Well Network Data	2	1	130
<u>Man's Activities</u>				
4301	Well Data (private and municipal)	3	2	119
4302	Public Water Supply Source	3	1	121
4303	Water Pollution Compliance Data	1	1	133
4304	Municipal Point Source Discharge	2	1	129
4305	Dam Inventory	3	1	120
4306	Chemical Spills Data	1	1	136
4307	Industrial Point Source Discharge	2	1	127

Data Code	Data Name	Number of Agencies		
		Using	Collecting	Use Count
<u>EARTH RESOURCES</u>				
<u>Soil and Surficial Materials</u>				
5101	Physical Analysis of Soil	5	3	113
5102	Chemical Analysis of Soil	4	3	120
5103	Stratigraphic Studies	3	1	123
5104	Descriptive Sections and Information of Soils	5	2	114
<u>Mineral and Energy Resources</u>				
5201	Mineral Production and Value	3	1	122
5202	List of Mineral Producers and Processors	2	2	123
5203	Inventory of Mined Lands	3	2	121
5204	Oil and Gas Production and Data	3	1	122
5205	List of Producers	2	1	128
5206	Inventory of Oil and Gas Resources	3	1	124
5207	Inventory of Coal Resources & Depletion	3	1	124
5208	Chemical Analysis of Minerals	2	1	132
5209	Physical Analysis of Minerals	2		132
<u>Geology</u>				
5301	Geomorphic Studies	1		134
5302	Structural Geology Studies	2	1	127
5303	Stratigraphic Studies	3	1	123
5304	Seismic Risk Zones	2		130
5305	Physical Analysis of Rock	2	2	127
5306	Chemical Analysis of Rock	2	2	129
5307	Descriptive Sections and Information of Rock Formations	4	2	118
5308	Inventory of Caves	3	2	122
5309	Physical Analysis of Rock	1	1	133
5310	Well Logs and Special Logs	3	1	124
5311	Subsurface Geologic Data	3	2	121
<u>Man's Activities</u>				
5401	Engineering Geology Reports	4	2	115
5402	Permits for Landfill and Toxic Waste Disposal Sites	1	1	134
5403	Inventory of Solid Waste Disposal Sites	1	1	133
5404	Chemical Analysis of Sewage and Leachate	1	1	135

Data Code	Data Name	Number of Agencies		
		Using	Collecting	Use Count
SOCIO-ECONOMIC RESOURCES				
<u>Social</u>				
6101	Decennial Census Data	4		119
6102	Current Land Use	4	1	120
6103	Highway Traffic Volume Counts	5	2	115
6104	Employment Data	5	1	115
6105	Manpower Resources	1	1	133
 <u>Economic</u>				
6201	Transportation Resources	3	2	122
6202	Utilities Resources	3		127
6203	Land Ownership	6	1	112
6204	Earnings and Income Data	3	2	124
6205	Roadway Characteristics - State County System	4	1	121
6206	Community Profile	3	1	125
6207	Land Values	5	1	117
6208	State Airport Directory	3	1	126
6209	Real Estate Activity (Land Survey User Fee)	4	1	121
6210	Index of Manufacturing	4		122
 <u>Recreation</u>				
6301	Park Use Data	4	1	122
6302	Recreation Facilities Inventories	3	1	125
6303	Public Use or Access Area	3	1	127
6304	Trail Inventory	3	1	125
6305	Bikeway Inventory	1	1	133
6306	Land and Water Conservation Fund Data	4		123
6307	Tourist Expenditure	3	1	127
 <u>Governmental</u>				
6401	Police Station Locations	0		138
6402	Fire Station Locations	1		132
6403	Public Use or Access Area	2		128
6404	City Government Officials	6		108
6405	State Government Officials	8		96
6406	County Government Officials	8		97
6407	Zoning Data	3		127
6408	School District	3		127

Data Code	Data Name	Number of Agencies		
		Using	Collecting	Use Count
<u>Governmental (continued)</u>				
6409	Fire District	2		127
6410	Library District	0		138
6411	Drainage District	2		130
6412	Water District	3		124
6413	Levee District	1		135
6414	Sewer District	3		127
<u>Archeologic and Historic</u>				
6501	Register of Historic, Archeological and Architectural Sites	5	1	118
6502	Known Archeological Resources	3		126
<u>Legislative</u>				
6601	Federal Legislation	8		98
6602	State Statutes	11	1	79
6603	Federal Regulations	10		87
6604	State Regulations	11	1	79

INSTRUCTIONS AND CODES FOR THE INVENTORY
OF
NATURAL RESOURCES DATA
AND
DATA SOURCES IN MISSOURI STATE GOVERNMENT

INTRODUCTION

Natural resources data is being continuously collected by the various state agencies in accordance with their individual statutory responsibilities. However, agency specialization alone does not identify completely the type of data that is being collected by any one agency. For this reason, there has been some lack of knowledge of the existence, residence, or status of natural resources data. Acquiring data from outside one's own agency can be cumbersome and time consuming, and this often causes potential users within the state agencies to forego the advantage of using all available data.

The first and most obvious solution to this problem is to develop an inventory of all natural resources data that is available within the various state agencies. The second and long range solution is to develop methods of sharing the data itself.

INVENTORY OF NATURAL RESOURCES DATA AND DATA SOURCES

The completed inventory of natural resources data and data sources will provide the following information.

1. A listing of natural resources data items that are collected by state agencies. Some data items will be given by a fairly broad subcategory and some will be very specific. This collected data should include only those items which are available or could be made available for use by other agencies.
2. Certain basic facts about the data. What format is the data in? How often is the data collected or revised? How is the data referenced geographically? To what extent is the state covered by this data? For how many years has this data been collected, what agency and what person should be contacted about this data, and what constraints will be placed on the sharing of this data?
3. A list of agencies which use the data items. This list will also show how often this data is used. A use generated priority rating of each data item will be given.

The inventory will be conducted by sending a questionnaire to all departments and agencies. The questionnaire will contain a preliminary listing of data items as previously determined by the Inter-Departmental Council for Natural Resources Information. Additional items may be added by the agency if necessary.

FORMS TO BE COMPLETED BY THE AGENCY

Agency Key Person

Each department and each division within the department should complete the agency key person form. Department name and division name will be given. The department number will be as shown on the enclosed department code number (a number between 1 and 14). The division number will be a number between 1 and 9, as determined by the department itself. In other words, each department can have up to nine divisions. Each department and each division should assign a number to each of their key employees, giving the name, address, and phone number of that key person. The key person will be the person that should be contacted about the use or collection of the data items. It is not necessary for each division to designate a key person. It is entirely appropriate for the department to designate one person as a key person for the entire department if it so chooses.

Inventory Form

Each division should complete an inventory form. The person completing the form should complete the department and the division name, the name of the person preparing the form, and his phone number. The agency number is the department number followed by the division number. The data code and data name will be typed on each one of the forms. The individual department and division should complete the form as to agency involvement, frequency of use, frequency of data collection, form of information, collection format, data coverage, data sharing potential, period of record, and key person for each of the items that they either use or collect. Items in which they have no contact should be left

blank. In completing the inventory form, each agency should note that the
first two items are to be completed only for items which the agency uses. The
last eight items on the inventory form are to be completed only if the data is
collected by the agency. A sample of a completed form is shown on page 79.

NATURAL RESOURCES DATA INVENTORY CODES

Code

Agency Involvement With the Data

- C - Collector Agency participates in collecting data and can supply this data to other users at the present time. The agency does its own collecting; contracts for or cooperatively works with one or more other agencies in securing the data.
- U - User Agency uses the particular kind of data regularly or periodically.
- B - Both User and
Collector
- Blank - not involved with this data

Frequency of Data Use

- 1 Use one or more times per week
- 2 Use one or more times per month
- 3 Use several times annually
- 4 Use annually
- 5 Use less than once annually
- 6 Unpredictable but will use if available

Frequency of Collection and Update of Data

- 1 Daily
- 2 Monthly
- 3 Quarterly
- 4 Longer intervals
- 5 Continuing collection at irregular intervals based on need

Primary Form of Information

- 1 Machine processable (numerical statistics in tabular form)
- 2 Manuscript
- 3 Mapped
- 4 Machine processable and manuscript
- 5 Machine processable and mapped
- 6 Mapped and manuscript
- 7 All three forms

Code

Primary Data Collection Format

(Nominal area for which the data is reported)

- 1 By township
- 2 By county
- 3 By river basin or watershed
- 4 By municipal boundary
- 5 By census tracts
- 6 Map quadrangles
- 7 Point source network
- 8 Random point source
- 9 Varying formats

Data Coverage

- 1 Statewide coverage
- 2 Coverage less than statewide
- 3 Very limited coverage

Data Sharing Potential

- 1 Data can be used readily by agencies in the present format.
- 2 Data could be used by other agencies after a data format modification.
- 3 Data could be used by other agencies with assistance from the collector.
- 4 Data could only be used by persons proficient in the technology of the data.
- 5 Data is not available for use by other agencies because of confidential, complex, or special nature of the data, or because it is completely outdated.

AGENCY KEY PERSON

Input Form

Department Natural Resources Number 9 (see dept. code)

Division Geology and Land Survey Number 5 (1 to 9)

Key Person Number	Name	Address	Phone
1	Robert E. Myers	P. O. Box 250, Rolla, MO 65401	314/364-1752

The Key Person is the person that should be contacted about the use or collection of the data.

DEPARTMENT CODES

Code

- 1 Department of Agriculture
- 2 Department of Conservation
- 3 Department of Consumer Affairs, Regulation & Licensing
- 4 Department of Elementary & Secondary Education
- 5 Department of Higher Education
- 6 Department of Highways
- 7 Department of Labor and Industrial Relations
- 8 Department of Mental Health
- 9 Department of Natural Resources
- 10 Department of Public Safety
- 11 Department of Revenue
- 12 Department of Social Services
- 13 Department of Transportation
- 14 Office of Administration

INVENTORY FORM

NATURAL RESOURCES DATA SOURCES INVENTORY

Agency Number 95

Department Natural Resources

Division Geology & Land Survey

Prepared by Robert E. Myers

Phone 314/364-1752

To be completed only for data which is collected by your agency

Data Code	Data Name	Agency Involvement Code	Frequency of Data Use	Frequency of Data Collection	Form of Information	Collection Format	Data Coverage	Data Sharing Potential	Period of Record		Key Person
									From	To	
	CARTOGRAPHIC DATA										
	<u>Aerial and Space Imagery</u>										
1101	Aerial Imagery (electronic origin)										
1102	Aerial Photographs	U	2								
1103	Space Imagery (electronic origin)										
1104	Space Photographs										
1105	Computer Compatible Tapes of Imagery										
	<u>National Topographic Map Series</u>										
1201	1:24,000 scale	U	1								
1202	1:62,500 scale										
1203	1:100,000 scale										
1204	1:250,000 scale										
1205	1:1,000,000 scale										
	<u>Special Base Maps</u>										
1301	Local Project Maps	B	1	5	3	1	3	3	1970	1977	
1302	Orthophoto Maps	U	2								
1303	Urban Area Maps	U	2								
1304	County Maps	U	2								
1305	Regional Maps										
1306	State Maps										
1307	Satellite Image Maps										

GENERAL OVERVIEW OF
MISSOURI AERIAL PHOTOGRAPHY AND SPACE IMAGERY INDEX

For many years the Division of Geology and Land Survey has served as a repository for aerial photography flown by the U. S. Geological Survey in its normal mapping operations within the State of Missouri. The Soil Conservation Service, as part of its nationwide program, has also flown photography over a large extent of the State of Missouri. From time to time complete sets of this photography have been acquired by the Division of Geology and Land Survey for its own inhouse operations. Both of these items of photography have been utilized extensively in normal surveying and geological research operations. As ERTS and LANDSAT imagery became available to this agency, a portion of that imagery depicting the State of Missouri has also been acquired by this agency. Some very significant research has been obtained through the utilization of this photography. In addition, some photography has been flown for inhouse projects from a photogrammetric standpoint and additional photography has been flown from a remote sensing or photo interpretation standpoint. At this time the aerial photography and remote sensing holdings of the Division of Geology and Land Survey contain thousands of images giving extensive coverage over the State of Missouri. Additional photography and imagery is being acquired for specific projects as the need arises. The holdings of the Division of Geology and Land Survey probably represent the largest library of aerial photography available in state government and could be utilized to a large extent by other agencies.

The Inter-Departmental Council for Natural Resources Information has recognized the need for a facility to coordinate the acquisition and dissemination of remote sensing imagery to the various state agencies. As a first step in determining the usability of imagery residing in the Division of

Geology and Land Survey, an index of this imagery has been developed. The Index of Aerial Photography and Space Imagery has been completed and is presently being placed in electronic data processing format. Programs have been written and tested that give complete listings of the aerial photography and space imagery. In addition to the tabular format, it has been determined that a graphical representation of the material within the Division of Geology and Land Survey would be quite advantageous.

The Composite Mapping System (CMS), developed by the Rocky Mountain Federation of States, has been utilized to develop a graphical representation of the imagery available. The CMS program utilizes a cell system. Each cell is represented by a character on the line printer. The scale selected for this graphical presentation gives the cell size of 3.75 minutes in latitude and 3.75 minutes in longitude. Actually, this is the division of the standard 7.5-minute U. S. Geological Survey quadrangle into four equal parts. Each of these grid cells is imprinted with a specific letter designating the type of photography or date of photography requested.

At the present time this index system and graphical representation is designed to display only those holdings of the Division of Geology and Land Survey. It is obvious that this system can be expanded to include not only the holdings of this Division but holdings of all state government; and in fact, all known photography. It is envisioned that tapes from the NCIC system will be merged with this system in order to portray the information obtained in those files as well as that obtained in the files at this Division. The smallest size photography which is shown in NCIC files is a quadrangle. It was felt that this resolution was not capable of producing results which were useful to state level organizations.

Therefore this Missouri system was designed to break down each quadrangle into four parts. All data has not been completely entered into the computer system, but is currently underway. The basic graphic system has been developed on a test area in the northeast corner of the State of Missouri. The following paper by Mr. Christopher Stohr, dated August, 1977, delineates the Missouri Aerial Photography and Space Imagery Index. Samples of printouts on the computer index and an example of the graphical representation from that index are enclosed at the end of Mr. Stohr's document.

MISSOURI AERIAL PHOTOGRAPHY
AND
SPACE IMAGERY INDEX DESIGN

Christopher J. Stohr
August, 1977

Missouri Aerial Photography
and
Space Imagery Index Design

The Aerial Photography Information Center (also called the Remote Sensing Information Center) is the proposed vehicle for the sharing of natural resources information and data gathered in part or in total by remote sensing. From a practical and immediate viewpoint, the system will be keyed to the inventory and distribution of information concerning planned, contracted, and flown aerial photography including specific information concerning ownership, availability, location and technical specifics.

Sharing information of the holdings of various state agencies on their planned flights will enable agencies wishing to obtain photography of a particular area to use existing photography if they can; allow small nearby areas to be flown on a single mission; or discover if another agency plans to fly the same area for other purposes. Significant savings in time and money can be realized.

In addition, this cooperation will open the door to greater sharing of other information gathered by participating agencies. Interests in some sites can allow for cooperative research and exchange of information of common interest. This is of particular interest where university students are searching for projects of a relevant, applied nature.

The concept of forming the proposed Missouri Aerial Photography and Space Imagery Index was born out of the considerable interest in the Index to Aerial and Space Photographic Coverage of Missouri, by Terry Barney and Chris Johannsen of the University of Missouri-Columbia, published in 1976. The success of the Index demonstrated to the Remote Sensing Applications Committee of the Natural Resources Information Council the need for an updated index on a regular basis.

The system as presently perceived will be a card type system where requests will be entered in a batch mode of a computer. Specific data concerning aerial photography missions or segments of flight lines will be entered into the computer including scale, film type, location data, etc. As inquiries are made the data will be searched, and based on the parameters specified, information concerning the available or planned photography will be printed out. See Figure 2, page 86.

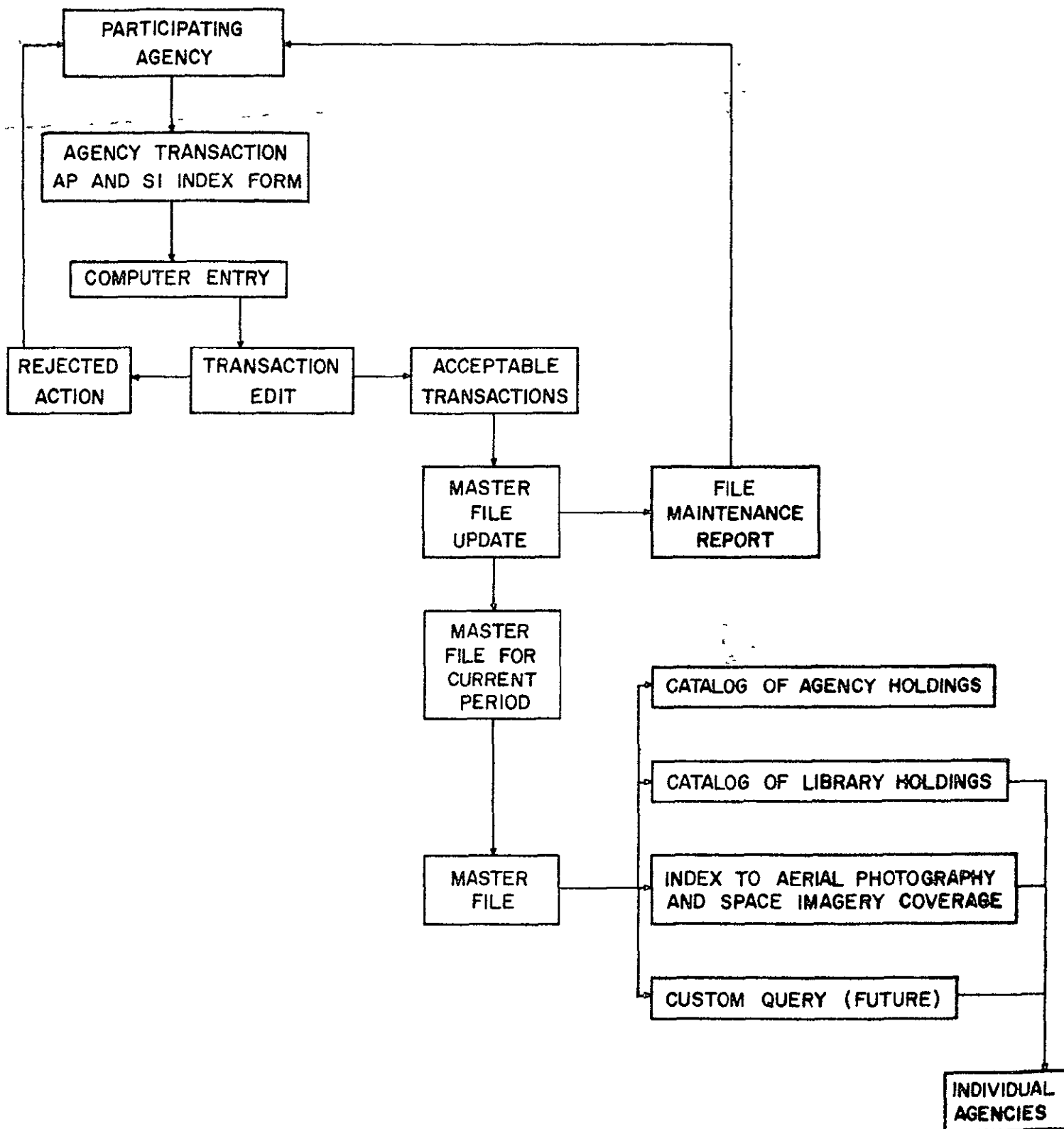

Figure 2

DATA PREPARATION

The Missouri Aerial Photography and Space Imagery Index contains the basic information required for identification of an aerial photography mission. The data base will allow for data entry by either of four formats:

- a) County
- b) 7.5-minute quadrangle
- c) Quadrilateral format
- d) 3.75-minute quadrangle

Each record within the data base will be identified by an agency code, mission number, and a system designation (or accession number). These three items must be entered on each summary record. Editing or updating the record will be accomplished by accessing each summary record by agency, mission and system designation, and then performing the indicated change or delete action upon that record; or by creating a new summary record.

Changes, deletions and updates will be reported to the participating agency. Each participating agency will be responsible for the editing of its own portion of the data file.

FILE CREATION AND MAINTENANCE (INPUT)

1. Agency Code (6 columns)

This is a 6-place designation that may be the "NAWDEX" designation for the funding agency or an alpha numeric designation for funding agencies not in that system. This designation must be used for all inputs into the system, and must match a table of legitimate codes. Failure to comply with the above may cause the action to be rejected, and an information message will be generated.

*2. Report Type (one column)

There are four possible entries for this one column code:

1. County format
2. 7.5-minute quadrangle format (carryover from NCIC system)
3. 3.75-minute quadrangle format
4. Quadrilateral format

Partial 3.75-minute quadrangle coverage may be entered in 25% increments (minimum coverage).

If there is no report type entered, or if the report type is not consistent with the proper entry for location data, the action will be rejected and an information message will be generated.

*3. System Origin Code (one column)

- 1 - Missouri Aerial Photography and Space Imagery Index
- blank - NCIC

This one column code is for determination of the origin of system from which data is to be entered. Not edited.

4. Date of Coverage (FIPS) (Six columns)

This is a 6-column code representing the day, month and year that the mission was flown. The first two columns are for the year; the second two columns are for month; and the last two columns are for the day.

Actions lacking a day or month entry will be accepted. However, actions lacking year entry will be rejected.

If an improbable date is entered (e.g., February 30), or if the entry is inconsistent with the status code (e.g., mission planned for 1943), then an information message will be generated.

5. Status (one column)

Actions lacking a valid code or containing a code inconsistent with the

*Indicated deviation from or addition to NCIC system

Date of Coverage generate an information message (e.g., change flown to planned).

Change actions with an invalid code will generate an information message.

Status codes are one column long:

1. Mission planned
2. Mission in progress
3. Mission completed

6. Agency Project Code (six columns)

The six column alphanumeric code is the agency's own and is not likely to be edited.

*7. Secondary Agency Code (six spaces)

This is a space for auxiliary information or agency codes such as NASA-ARC accession number. This will be edited manually and is alphanumeric.

8. FIPS Code - State and County (five columns)

Add or change actions will be rejected and an information message generated if the "county format" report type of entry was indicated and this field is blank.

The FIPS state and county codes are listed in the appendix. An invalid statement will cause rejection and information message to be generated.

9. Image Scale (seven columns)

Add actions that are blank will be left blank; will be manually edited.

This represents the denominator of the whole fraction scale of the photography or imagery. For example, imagery at a scale of 1:20,000 would be entered as 20000.

*10. Sensor Class (two columns)

This will identify the sensor used in the collection of photography or imagery,

Sensor will include:

- 01 Vertical cartographic
- 02 Vertical reconnaissance
- 03 Oblique (implies reconnaissance photography)
- 04 Thermal infrared scanner or imager
- 05 Radar scanner or imager
- 06 Multispectral scanner or imager
- 10 Other (if other is used, sensor should be described in remarks)

Field will be ignored if invalid entry made and information message generated.

11. Focal Length (two columns)

This represents the focal length of the camera or sensor expressed in inches only.

- 01 = 1.75" or 44mm
- 02 = 3" or 76mm
- 03 = 3.46" or 88mm
- 04 = 6" or 152mm
- 05 = 8.25" or 210mm
- 06 = 12" or 305mm
- 07 = 24" or 610mm
- 08 = Other

This field will be manually edited if necessary.

12. Specifications (one column)

Does camera meet standard photography calibration specifications? Blank if unknown. Y = Yes; N = No.

*13. Film Format (two columns)

This represents the original format in inches only of the photography or imagery. It may be left blank if not known. Field will not be edited.

- | | | |
|----|-----------------------------|--------------------------|
| 01 | 2.76" | or 70mm |
| 02 | 4.5" x 4.5" | or 11cm x 11cm |
| 03 | 9" x 9" | or 23cm x 23cm |
| 04 | 9" x 18" | or 23cm x 46cm |
| 05 | Other (describe in Remarks) | |
| 06 | 1.38" | or 35mm |
| 07 | 2.76" | or 70mm continuous strip |
| 08 | 9" | or 23cm continuous strip |
| 09 | 18" x 18" | or 46cm x 46cm |
| 10 | 27" x 27" | or 69cm x 69cm |
| 11 | 36" x 36" | or 98cm x 98cm |

Field will be ignored and an information message generated if it is invalid add or change action.

*14. Film Type (one column)

This indicates the emulsion of the photography.

- 1 - B & W Infrared
- 2 - Color Infrared
- 3 - Color
- 4 - B & W
- 5 - Other (describe in Remarks)
- 6 - False Color Composite

Field will be ignored if invalid statement entered and an information message will be generated.

*15. Genre (one column)

This designates the medium the film emulsion is on and whether it is a film positive or negative.

- | | |
|---------------------------|-------------------|
| 1 - Positive Print | 5 - Mosaic |
| 2 - Positive Transparency | 6 - Orthophoto |
| 3 - Negative Print | 7 - Computer Tape |
| 4 - Negative | 8 - Other |

Field will be ignored if an invalid entry is made, and an information message is generated.

*16. Cloud Cover (two columns)

This designates the percent of cloud cover over the mission. Field should be to the nearest whole percent. Field will be ignored if an invalid entry is made, and an information message generated.

- | | |
|----------|----------|
| 00 = 0% | 60 = 60% |
| 10 = 10% | 70 = 70% |
| 20 = 20% | 80 = 80% |
| 30 = 30% | 90 = 90% |
| 40 = 40% | |
| 50 = 50% | |

*17. Quadrangle Coverage (two columns)

This designates the percent of 3 3/4 quadrangle coverage. Field should be to the nearest ten percentile. Field will be ignored if an invalid entry is made, and an information message generated.

- | | |
|---------|---------|
| 1 = 10% | 6 = 60% |
| 2 = 20% | 7 = 70% |
| 3 = 30% | 8 = 80% |
| 4 = 40% | 9 = 90% |
| 5 = 50% | |

18. Remarks (space as needed)

19. Action Code (one column)

For initial run all actions will be entered as add actions and processed accordingly. Subsequent runs will require change or delete entries.

Change or delete actions will require Agency, Agency Project Code, and Secondary Agency Code. An invalid statement will result in rejection of the action and information message to be generated.

1 - Add record

2 - Change existing record

3 - Delete existing record

*20. S.E. Corner Coordinates (13 columns)

This is for location data: Enter latitude degrees and minutes in first five columns (e.g. 40° 07.50' would be entered 400750). Enter longitude in the next six columns in degrees and minutes (e.g. 101° 03.75' would be entered 1010375).

Enter to the nearest 3-3/4 minutes of a degree only. Invalid entry will be rejected and an information message generated. Entry will also be rejected if the "quad format" is not specified. Latitude first; longitude second.

21. Number of Contiguous Quadrangles (three columns)

This represents the number of 7.5' or 3.75' quadrangles in a north-south tier. Required if input by quadrangles. Number of Quadrangles should reflect that stated in report type.

*22. Quadrilateral Coordinates (18 columns)

This is location data which is coded by degrees, minutes and tenths of a minute for each corner of a straight flight line segment as described in 20. Three corners are to be entered; the fourth will be calculated. Hence the general configuration will be that of a parallelogram. Latitude entered first; longitude second.

Any corner will be entered, then proceed in a clockwise direction until three coordinates are entered.

Coordinate entries will be as follows:

first 3 columns - degrees

next 2 columns - minutes

final 1 column - nearest tenth of a minute (6 seconds = .1 minute)

*23. Libraries (space as needed)

This will list firstly the contractor, followed by a tabular listing of other agencies which hold copies of the photography or imagery. For example:

SURDEX Corporation

Missouri Geology and Land Survey

Missouri Department of Conservation-Columbia

Missouri Air Conservation Commission

U. S. Environmental Protection Agency

SURDEX Corporation would be the contractor which performed the flying and holds the negatives or a reproducible copy of the film. The other agencies are those which hold copies of the mission photography.

The data for the Missouri Aerial Photography and Space Imagery Index will originate from forms submitted by local, state and federal agencies and private concerns. The form is structured after the input described in the File Creation and Maintenance Section described above. A blank form and examples are found in the appendix.

INDEX MAINTENANCE

The Index programming will assign USGS quadrangle names to aerial photography which is entered in the 7.5 minute report type. The photography coordinates must be the same coordinate designations (0.0, 7.5, 15, 22.5, 30, 37.5, 45, 52.5) as the USGS 7.5 topographic series (1:24,000).

USER OUTPUTS

Three standard outputs will be available:

- a) The Catalog of Agency Holdings will list the photography and imagery flown for an agency, industry, etc.
- b) The Catalog of Library Holdings which will list the photography and imagery in the possession of an agency, contractor, industry, sorted according to agency.
- c) The Missouri Aerial Photography and Space Imagery Index which graphically shows aerial photography coverage for a Regional Planning District and has a tabular legend keyed to the graphics which identifies the photography.

The Catalog of Agency Holdings will list the acquisition of government agencies or private concerns cooperating in the program. The photography and imagery will be sorted by agency, date, sensor, specifications, scale, cloud cover, focal length, format, film type, and lastly, genre. Agency codes, remarks, libraries and location data are not sorted or in this catalog, but are listed for mission identification and informational purposes. The catalog will present the holdings as in Figure 3, page 97.

Sorting of the data classes will be as follows:

Agency - according to alphabetic order

Code - not sorted

Date - latest to earliest date

Sensor - 1) vertical cartographic
2) vertical reconnaissance
3) oblique
4) thermal IR scanner or imager
5) radar scanner or imager
6) other (describe in remarks)

Specifications - calibrated photography will be listed first

Scale - smallest to largest scale

Cloud Cover - least to most cover

Focal Length - smallest to largest, then other

- Format -
- 1) 2.76" or 70mm
 - 2) 4.5" x 4.5" or 11cm x 11cm
 - 3) 9" x 9" or 23cm x 23cm
 - 4) 9" x 18" or 23cm x 46cm
 - 5) other
 - 6) 1.38" or 35mm
 - 7) 2.76" or 70 mm continuous strip
 - 8) 9" or 23cm continuous strip
 - 9) 18" x 18" or 46 mm x 46mm
 - 10) 27" x 27" or 69mm x 69mm
 - 11) 36" x 36" or 98mm x 98mm

- Film Type -
- 1) Black and white infrared
 - 2) Color infrared
 - 3) Color
 - 4) Black and white
 - 5) Other
 - 6) False color composite

- Genre -
- 1) Positive print
 - 2) Positive transparency
 - 3) Negative print
 - 4) Negative transparency
 - 5) Mosaic
 - 6) Orthophoto
 - 7) Computer tape
 - 8) Other

Remarks - Not sorted

ORIGINAL PAGE IS
OF POOR QUALITY

AERIAL PHOTOGRAPHY AND SPACE IMAGERY INDEX - AGENCY INDEX

Agency	Code	Date	Sensor	Specifications	Scale	Cloud Cover	Focal Length	Format	Film Type	Genre
Example: National Aeronautics and Space Administration - Ames Research Center Moffett Field, California										
COMPLETED										
NASA-Ames	73-058 00716	6/3/73	Vert. Carto.	Cali- brated	1:756,000	0%	1-3/4"	70mm	Color	Positive Transparency
Location: N41°45.50' W90°37.9'; N40°21.10' W91°15.00'; N39°17.00' W90°56.70'; N91°01.00' W37°38.90'										
Libraries: <u>NASA-Ames</u> ; Missouri Geology and Land Survey; EROS Data Center										
Remarks: Spring flood assessment										

Example: United States Geological Survey, Topographic Div., 1400 Independence Rd., Rolla, Missouri 65401

CONTRACTED										
-97- USGS	VCPG	Feb. 78	Vert. Carto.	Cali- brated	1:23,000	0%	6"	9"x9"	B & W	Positive Print
Location: SE Corner N39°07.50' W91°52.50' Mexico West, Molino, Paris East										
Libraries: <u>USGS</u>										

Example: Agricultural Stabilization and Conservation Service, 10th and Walnut, Columbia, Missouri 65201

PLANNED										
ASCS	TK 29027	1978	Vert. Carto.			0%			B & W	Mosaic
Location: Callaway County										
Libraries: <u>ASCS</u>										
ASCS	TK 29027	1978	Vert. Carto.		1:20,000	0%	8.25"	9"x9"	B & W	Positive Print
Location: Callaway County										
Libraries: <u>ASCS</u>										

Figure 3

Libraries - Contractor listed, then agencies having a copy of photography in any order. Ideally, Missouri agencies and private concerns will be segregated from Federal and out-of-state concerns.

Location - Not sorted

The Catalog of Library Holdings will list the photography and imagery owned by government agencies or private concerns cooperating in the program. The photography and imagery will be sorted by library, agency, date, sensor, specifications, scale, cloud cover, focal length, format, film type and lastly genre. Agency codes, remarks and location data will not be sorted in this catalog, but are listed for mission identification and informational purposes. The data will be presented as in Figure 4, page 99.

Sorting of the data will be as follows:

Libraries - listed according to alphabetic order

Agency - listed according to alphabetic order

Code - not sorted

Date - latest to earliest date

Sensor - 1) vertical cartographic

2) vertical reconnaissance

3) oblique

4) thermal IR scanner or imager

5) radar scanner or imager

6) other (describe in remarks)

Specifications - calibrated photography will be listed first

Scale - smallest to largest scale

Cloud Cover - least to most cover

Focal Length - smallest to largest, then other

Format - 1) 2.76" or 70mm

2) 4.5" x 4.5" or 11cm x 11cm

3) 9" x 9" or 23cm x 23cm

AERIAL PHOTOGRAPHY AND SPACE IMAGERY INDEX - LIBRARY INDEX

Agency Location	Code	Date	Sensor	Specifications	Scale	Cloud Cover	Focal Length	Format	Film Type	Genre
Example: Missouri Department of Natural Resources, Division of Geology & Land Survey, P. O. Box 250, Rolla, Mo. 65401										
COMPLETED										
NASA-Ames	73-058 00716	6/3/73	Vert. Carto.	Cali- brated	1:756,000	0%	1.75"	70mm	Color	Positive Transparency
Location:	N41°45.50' W90°37.90'; N40°21.10' W91°15.00'; N39°17.00' W90°56.70'; N91°01.00' W37°38.90'									
USGS	VCPG	Feb. 73	Vert. Carto.	Cali- brated	1:23,000	0%	6"	9"x9"	B & W	Positive Print
Location:	SE Corner N39°07.50' W91°52.50' Mexico West, Molino, Paris East									
ASCS	TK 29027	1963	Vert. Carto.			0%			B & W	Mosaic
Location:	Callaway County									
ASCS	TK 29027	1963	Vert. Carto.		1:20,000	0%	8.25"	9"x9"	B & W	Positive Print
Location:	Callaway County									

-66-

Figure 4

- 4) 9" x 18" or 23cm x 46cm
- 5) other
- 6) 1.38" or 35mm
- 7) 2.76" or 70mm continuous strip
- 8) 9" or 23cm continuous strip
- 9) 18" x 18" or 46mm x 46mm
- 10) 27" x 27" or 69mm x 69mm
- 11) 36" x 36" or 98mm x 98mm

Film Type - 1) Black and white infrared

2) Color infrared

3) Color

4) Black and white

5) Other

6) False color composite

Genre - 1) Positive print

2) Positive transparency

3) Negative print

4) Negative transparency

5) Mosaic

6) Orthophoto

7) Computer tape

8) Other

Remarks - Not sorted

Location - Not sorted

The Missouri Aerial Photography and Space Imagery Index will be a graphical and tabular representation of photography and imagery that has been collected over the state by cooperating agencies and private concerns. The index will follow

the "Index to Aerial and Space Photographic Coverage of Missouri", by Terry Barney and Chris Johannsen (Extension Publication M-102), quite closely. The index will include:

- a) Agency descriptions of their use of aerial photography.
- b) How to obtain information about the photography or imagery and guidelines on ordering the photography or imagery.
- c) Index maps of the twenty regional planning areas of Missouri will graphically depict photography and imagery from Federal, state and private holdings available to the public (see Figure 5, page 102).
- d) Landsat 1 and 2 coverage over Missouri will be depicted showing center points and approximate boundaries of the imagery and a listing of ten (10) recent frames with less than 10% cloud cover. Imagery owned by the state will be shown by library.
- e) Skylab photography will be shown by flight lines.
- f) Private photography and imagery will be shown by flight line (small areas such as towns, highways, etc. will be described).
- g) An appendix will show how data about photography is entered into the index data bank and how the Catalog of Agency Holdings and Catalog of Library Holdings may be ordered and used.

The index will resemble Figure 5 on page 102, except that the graphic portion will have flightlines represented by symbols generated by a line printer; hence a flightline may appear "blocky". Fewer flightlines will be depicted on maps to avoid confusion where too many symbols will overlap.

CUSTOM QUERY

No provision has been made for producing a custom queries. However, the possibility of future implementation of a custom query system is being pursued.

ABCD Region

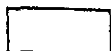
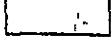
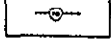
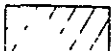
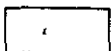
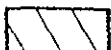
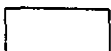
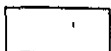
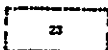
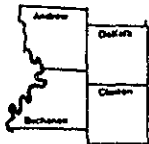

COMPLETE REGIONAL COVERAGE

NASA Mission 106 Oct 2, 1969

COMPLETE COUNTY COVERAGE

Andrew ASCS—1939 1947 1954 1960 1967, Sept 4 5, 1974
 Buchanan ASCS—1936 1940 1953, 1958 1965 May 19 1972
 Clinton ASCS—1936 1940 1951 1957, 1963, Sept 24 30 1969
 DeKalb ASCS—1936 1940, 1952 1958 1965 May 18 1972
 ,SCS—Sept 1974

PARTIAL COUNTY COVERAGE

USGS

[6] 1948 1 17000 EA	[66] 1969 1 23000 VCDE	[75] 1972 1 30000 VCWB
[23] 1960 1 24000 VADY	[73] 1960 1 20000 VCKR	[95] 1947 1 17000 EBB

NASA

Corn Blight 1971

Mission 213 Missouri River Basin Sept 11 1972

Mission 261 Kansas City/Moberly Nov 28, 1973

Flight 74 077 May 15, 1974

Mission 300 Kansas City Feb 1975

NOAA June 3, 1960, 1 33000 B&W
 Sept 7 1961, 1 36000 B&W July
 T2 1965 1 30000 B&W, May 14
 1971 1 30000 B&W Aug 27, 1972
 1 30000 B&W

MISSOURI STATE HIGHWAY DEPARTMENT

DIVISION OF PARKS AND RECREATION
 Wallace State Park no date medium

PRIVATE IMAGERY

CITIES AND TOWNS

[A] M J Harden St Joseph, Cameron Plattsburg, Lathrop, Gower, Savannah Trimble
 [B] Fairchild Aeromaps - St Joseph, Aug 3, 1973 1 26400 B&W

KANSAS CITY POWER & LIGHT Jan 5, 1964, Feb 3, 1972

ABCD Region

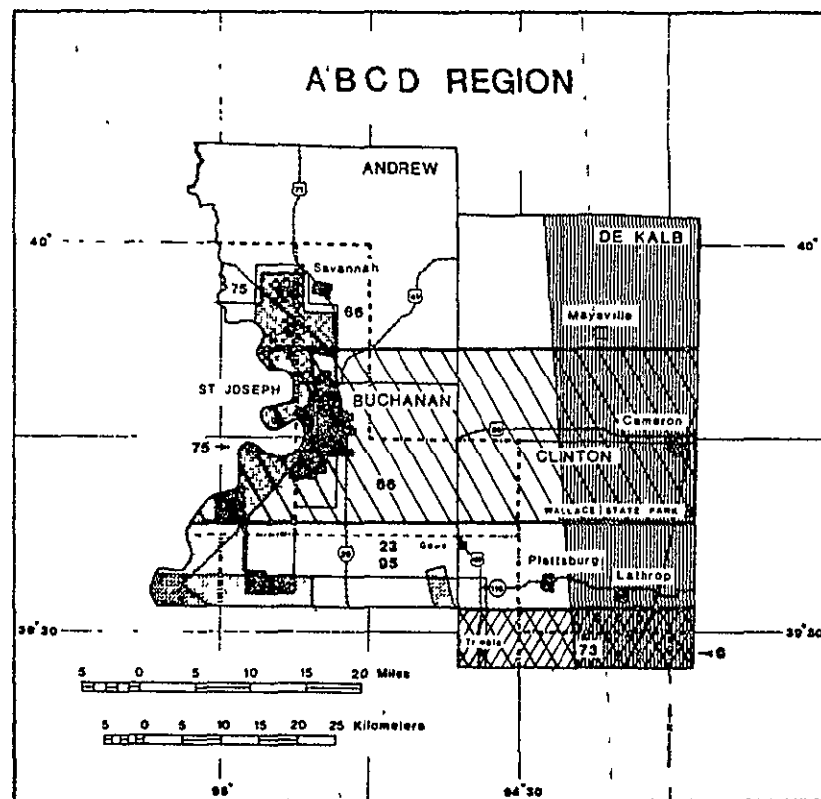

ORIGINAL PAGE IS OF POOR QUALITY

Figure 5

APPENDIX

1. Aerial Photography Summary Record Form

Library _____

Contractor _____

AERIAL PHOTOGRAPHY SUMMARY RECORD

AGENCY _____

DATE OF COVERAGE _____

REPORT (Circle One):

STATUS:

- 1. County _____
- 2. 7.5 Minute Quad _____
- 3. 3.75 Minute Quad _____
- 4. Quadrilateral (flightline)

- 1. Planned
- 2. In progress
- 3. Completed

AGENCY CODE _____

SECOND CODE _____

SCALE _____

SENSOR CLASS:

SPECS: Camera Calibrated: Yes No

- 1. Vertical Cartographic
- 2. Vertical Reconnaissance
- 3. Oblique
- 4. Thermal
- 5. Radar
- 6. MSS
- 7. _____

PERCENT CLOUD COVER _____

FOCAL LENGTH:

- 1. 1.75" 44mm
- 2. 3.0" 76mm
- 3. 3.46" 88mm
- 4. 6" 152mm
- 5. 8.25" 210mm
- 6. 12" 305mm
- 7. 24" 610mm
- 8. Other

FILM FORMAT:

- 1. 2.76" 70mm
- 2. 4.5 x 4.5" 11cm
- 3. 9 x 9" 23cm
- 4. 9 x 18" 23 x 46cm
- 5. Other
- 6. 1.38" 35mm
- 7. 2.76" 70mm (continuous strip)
- 8. 9" 23cm
- 9. 18 x 18" 46 x 46cm
- 10. 27 x 27" 69 x 69cm
- 11. 36 x 36" 98 x 98cm

FILM TYPE:

- 1. B & W IR
- 2. Color IR
- 3. Color
- 4. B & W
- 5. Other
- 6. False Color Composite

LOCATION:

GENRE:

- 1. Positive Print
- 2. Positive Transparency
- 3. Negative Print
- 4. Negative Transparency
- 5. Mosaic
- 6. Orthophoto
- 7. Computer Tape
- 8. Other

REMARKS:

TIERS:

Shelf:

Drawer:

Cannister:

File:

EXAMPLE COMPUTER PRINTOUTS

- A. Sample Listing of Index Data (Figs. 6-a and 6-b)
- B. Sample Graphic Representation of Index
 - 1. County Locations (Fig. 7)
 - 2. County Overlay (Fig. 8)
 - 3. Four Types of Data and County Overlay (Fig. 9)

AFRIAL PHOTOGRAPHY AND SPACE IMAGERY INDEX

AGENCY	CODE	DATE	STATUS	SPECS	SCALE	% COVER	FOCAL	FILM	FORMAT	FILM TYPE	FILM GENRE
039085	03908	094050			0392700					OTHER	
USGS	VADV	6101	COMPLETED		18000	00	6.0	9X9		B&W	POSITIVE PRINT
	SE CORNER=	039 45.00 091 52.50		NUMBER OF TIERS=	2						
NASAJS	261	731128	COMPLETED		130000	10	6.0	9X9		COLOR	POSITIVE TRANSPARENT
	LOCATION=	039 31.40 092 00.00 039 31.40 091 45.00			039 16.40 091 45.00						
ASCS	BYL	39	COMPLETED							B&W	MOSAIC
	COUNTY=	AUDRAIN									
ASCS	BYL	62	COMPLETED							B&W	MOSAIC
	COUNTY=	AUDRAIN									
ASCS	TK	41	COMPLETED							B&W	MOSAIC
	COUNTY=	CALLAWAY									
ASCS	TK	50	COMPLETED		20000		8.25	9X9		B&W	POSITIVE PRINT
	COUNTY=	CALLAWAY									
ASCS	TK	63	COMPLETED							B&W	MOSAIC
	COUNTY=	CALLAWAY									
ASCS	CM1	40	COMPLETED							B&W	MOSAIC
	COUNTY=	STONE									
ASCS	CML	50	COMPLETED		20000	00	8.25	9X9		B&W	POSITIVE PRINT
	COUNTY=	STONE									
ASCS	CML	62	COMPLETED							B&W	MOSAIC
	COUNTY=	STONE									
ASCS	TM	41	COMPLETED		20000		8.25	9X9		B&W	POSITIVE PRINT
	COUNTY=	LINCOLN									
ASCS	TM	41	COMPLETED							B&W	MOSAIC
	COUNTY=	LINCOLN									
ASCS	TM	63	COMPLETED							B&W	
	COUNTY=	LINCOLN									
ASCS	BYX	50	COMPLETED		20000	00	8.25	9X9		B&W	POSITIVE PRINT
	COUNTY=	MORGAN									
ASCS	BYX	39	COMPLETED			00				B&W	MOSAIC
	COUNTY=	MORGAN									
ASCS	BYX	62	COMPLETED			00				B&W	MOSAIC
	COUNTY=	MORGAN									
ASCS	TL	50	COMPLETED		20000		8.25	9X9		B&W	POSITIVE PRINT
	COUNTY=	NEW MADRID									

-106-

ORIGINAL PAGE IS
OF POOR QUALITY

LENGTH MEASUREMENTS ARE IN INCHES - LOCATION MEASUREMENTS ARE IN DEGREES MINUTES.HUNDRETHS OF MINUTES

Figure 6-a

AERIAL PHOTOGRAPHY AND SPACE IMAGERY INDEX

AGENCY	CJDE	DATE	STATUS	SPECS	SCALE	% COVER	FOCAL	FILM	FORMAT	FILM TYPE	FILM GENRE		
LOCATION													
ASCS	TL	41	COMPLETED							B&W	MOSAIC		
	COUNTY=	NEW MADRID											
ASCS	TL	63	COMPLETED							B&W	MOSAIC		
	CJUNTY=	NEW MADRID											
ASCS	TJ	41	COMPLETED							B&W	MOSAIC		
	CJUNTY=	POLK											
ASCS	TJ	59	COMPLETED				8.25		9X9	B&W	POSITIVE PRINT		
	COUNTY=	POLK											
ASCS	TJ	63	COMPLETED							B&W	MOSAIC		
	COUNTY=	POLK											
ASCS	TJ	69	COMPLETED							B&W	MOSAIC		
	COUNTY=	POLK											
USGS	CDL	5704	COMPLETED					18000		6.0	9X9	B&W	POSITIVE PRINT
	SE CORNER=	039	30.00 091	52.50	NUMBER OF TIERS=	002							
USGS	VCPG	7102	COMPLETED					23000		6.0	9X9	B&W	POSITIVE PRINT
	SE CORNER=	039	07.50 091	52.50	NUMBER OF TIERS=	003							
USGS	VADV	6101	COMPLETED					18000		6.0	9X9	B&W	POSITIVE PRINT
	SE CORNER=	039	45.00 091	45.00	NUMBER OF TIERS=	002							
USGS	CDL	5704	COMPLETED					18000	00	6.0	9X9	B&W	POSITIVE PRINT
	SE CORNER=	039	30.00 091	45.00	NUMBER OF TIERS=	002							
USGS	VCPG	7102	COMPLETED					23000		6.0	9X9	B&W	POSITIVE PRINT
	SE CORNER=	039	00.00 091	45.00	NUMBER OF TIERS=	004							
USGS	DZ	47	COMPLETED					27200	00	OTHER	9X9	B&W	POSITIVE PRINT
	SE CORNER=	039	45.00 091	37.50	NUMBER OF TIERS=	001							
USGS	CDL	5704	COMPLETED					18000		6.0	9X9	B&W	POSITIVE PRINT
	SE CORNER=	039	30.00 091	37.50	NUMBER OF TIERS=	002							
USGS	VDDZ	7301	COMPLETED					90000		6.0	9X9	B&W	POSITIVE PRINT
	SE CORNER=	039	15.00 091	37.50	NUMBER OF TIERS=	002							
USGS	DZ	47	COMPLETED					27200	00	OTHER	9X9	B&W	POSITIVE PRINT
	SE CORNER=	039	45.00 091	30.00	NUMBER OF TIERS=	001							
USGS	CDL	5704	COMPLETED					18000		6.0	9X9	B&W	POSITIVE PRINT
	SE CORNER=	039	30.00 091	30.00	NUMBER OF TIERS=	002							
USGS	VDDZ	7301	COMPLETED					90000	00	6.0	9X9	B&W	POSITIVE PRINT
	SE CORNER=	039	15.00 091	30.00	NUMBER OF TIERS=	002							
USGS	VCCX	6903	COMPLETED					20000	00	6.0	9X9	B&W	POSITIVE PRINT
	SE CORNER=	039	30.00 091	22.50	NUMBER OF TIERS=	004							

ORIGINAL PAGE IS
OF POOR QUALITY

-107-

LENGTH MEASUREMENTS ARE IN INCHES - LOCATION MEASUREMENTS ARE IN DEGREES MINUTES.HUNDREDTHS OF MINUTES

Figure 6-b

```

45
46 1AAAAAAAAAAAAAABBBB BBBB
47 1AAAAAAAAAAAAAABBBB BBBB
48 1AAAAAAAAAAAAAABBBB BBBB
49 1AAAAAAAAAAAAAABBBB BBBB
50 1AAAAAAAAAAAAAABBBB BBBB
51 1AAAAAAAAAAAAAABBBB BBBB
52 1AAAAAAAAAAAAAABBBB BBBB
53 1AAAAAAAAAAAAAABBBB BBBB
54 2AAAAAAAAAAAAAABBBB BBBB
55 2CCCCCCCCCCCCCBBB BBBB
56 2CCCCCCCCCCCCCBBB BBBB
57 2CCCCCCCCCCCCCDDDD DDDD
58 2CCCCCCCCCCCCCDDDD DDDD
59 2CCCCCCCCCCCCCDDDD DDDD
60 2CCCCCCCCCCCCCDDDD DDDD
61 2CCCCCCCCCCCCCDDDD DDDD
62 2CCCCCCCCCCCCCDDDD DDDD
63 2CCCCCCCCCCCCCDDDD DDDD
64 FCCCCCCCCCCCCCCDDDD DDDD
65 ECCCCCCCCCCCCCDDDD DDDD
66 ECCCCCCCCCCCCCDDDD DDDD
67 EEEEEEEEEEEEEEEEEGGGGGGGGGGGG
68 FEEEEEEEEEEEEEEEEGGGGGGGGGGGG
69 EEEEEEEEEEEEEEEEEGGGGGGGGGGGG
70 EEEEEEEEEEEEEEEEEGGGGGGGGGGGG
71 EEEEEEEEEEEEEEEEEGGGGGGGGGGGG
72 FEEEEEEEEEEEEEEEEGGGGGGGGGGGG
73 EEEEEEEEEEEEEEEEEGGGGGGGGGGGG
74 EEEEEEEEEEEEEEEEEGGGGGGGGGGGG
75 EEEEEEEEEEEEEEEEEGGGGJJJJJJJJJJ
76 FEEEEEEEEEEEEEEEEJJJJJJJJJJJJ
77 EEEEEEEEEEEEEEEEEJJJJJJJJJJJJ
78 HHIIIIIIIIIIIIIIIIIJJJJJJJJJJJJ
79 HHIIIIIIIIIIIIIIIIIJJJJJJJJJJJJ
80 HHIIIIIIIIIIIIIIIIIJJJJJJJJJJJJ
81 HHIIIIIIIIIIIIIIIIIJJJJJJJJJJJJ
82 HHIIIIIIIIIIIIIIIIIJJJJJJJJJJJJ
83 HHIIIIIIIIIIIIIIIIIJJJJJJJJJJJJ
84 HHIIIIIIIIIIIIIIIIIJJJJJJJJJJJJ
85 HHIIIIIIIIIIIIIIIIIJJJJJJJJJJJJ
86 HMMMMMMMMMMMMMMMMMMMMJJJJJJJJJJJJ
87 HMMMMMMMMMMMMMMMMMMMMMMMMMMMMMMMM
88 HMMMMMMMMMMMMMMMMMMMMMMMMMMMMMMMM
89 LLLLLLLLLLMMMMMMMMMMMMMMMMMMMM
90 LLLLLLLLLLMMMMMMMMMMMMMMMMMMMM
91 LLLLLLLLLLMMMMMMMMMMMMMMMMMMMM
92 LLLLLLLLLLMMMMMMMMMMMMMMMMMMMM
93 LLLLLLLLLLMMMMMMMMMMMMMMMMMMMM
94 LLLLLLLLLLMMMMMMMMMMMMMMMMMMMM
95 LLLLLLLLLLNNNNNNNNNNNNNNNNNN
96 LLLLLLLLLLNNNNNNNNNNNNNNNNNN
97 LLLLLLLLLLNNNNNNNNNNNNNNNNNN
98 LLLLLLLLLLNNNNNNNNNNNNNNNNNN
99 LLLLLLLLLLNNNNNNNNNNNNNNNNNN
100 LLLLLLLLLLNNNNNNNNNNNNNNNNNN
101 LLLLLLLLLLNNNNNNNNNNNNNNNNNN
102 LLLLLLLLLLNNNNNNNNNNNNNNNNNN
103 LLLLLLLLLLNNNNNNNNNNNNNNNNNN
104 LLLLLLLLLLNNNNNNNNNNNNNNNNNN
105 LLLLLLLLLLNNNNNNNNNNNNNNNNNN
106 ULLLLLNNNNNNNNNNNNNNNNNN
107 ULLLLLNNNNNNNNNNNNNNNNNN
108 UUUUUUUUUUUUUUUUUUUUUUUUUUUUUUU
109 UUUUUUUUUUUUUUUUUUUUUUUUUUUUUUU
110 UUUUUUUUUUUUUUUUUUUUUUUUUUUUUUU
111 UUUUUUUUUUUUUUUUUUUUUUUUUUUUUUU
112 UUUUUUUUUUUUUUUUUUUUUUUUUUUUUUU
113 UUUUUUUUUUUUUUUUUUUUUUUUUUUUUUU
114 UUUUUUUUUUUUUUUUUUUUUUUUUUUUUUU
115 UUUUUUUUUUUUUUUUUUUUUUUUUUUUUUU
116 UUUUUUUUUUUUUUUUUUUUUUUUUUUUUUU
117 UUUUUUUUUUUUUUUUUUUUUUUUUUUUUUU
118 ZZZZVVVVVVVVVVVVVVVVVVVVVVVVVVVV
119 ZZZZVVVVVVVVVVVVVVVVVVVVVVVVVVVV
120 ZZZZV3333333333333333333333333333

```

NE Missouri
Computer Printout
Showing Counties

Figure 7

1 2 3 4 5 6 7
12345678901234567890123456789012345678901234567890123456789012345

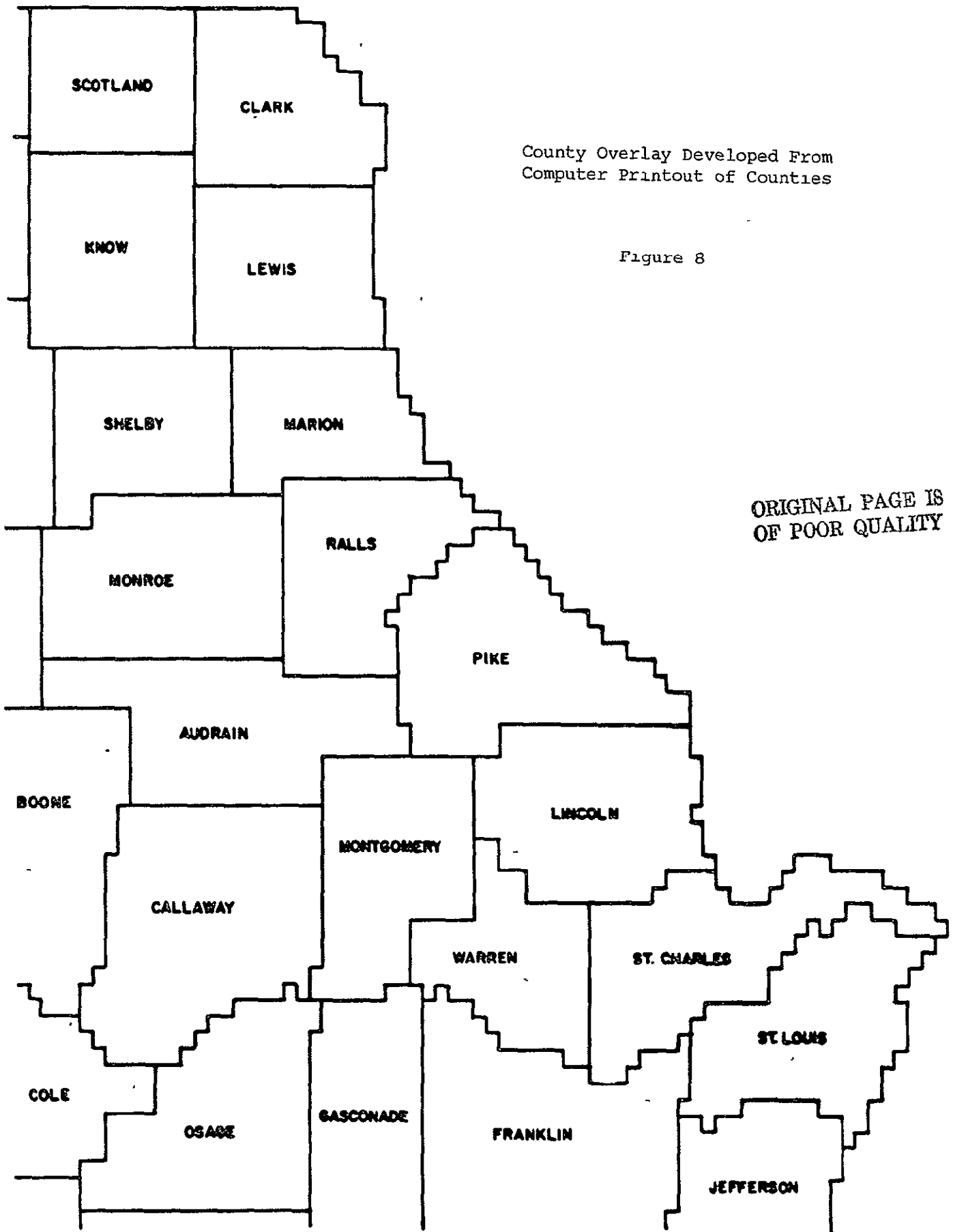

County Overlay Developed From
Computer Printout of Counties

Figure 8

ORIGINAL PAGE IS
OF POOR QUALITY

45
46
47
48
49
50
51
52
53
54
55
56
57
58
59
60
61
62
63
64
65
66
67
68
69
70
71
72
73
74
75
76
77
78
79
80
81
82
83
84
85
86
87
88
89
90
91
92
93
94
95
96
97
98
99
100
101
102
103
104
105
106
107
108
109
110
111
112
113
114
115
116
117
118
119
120

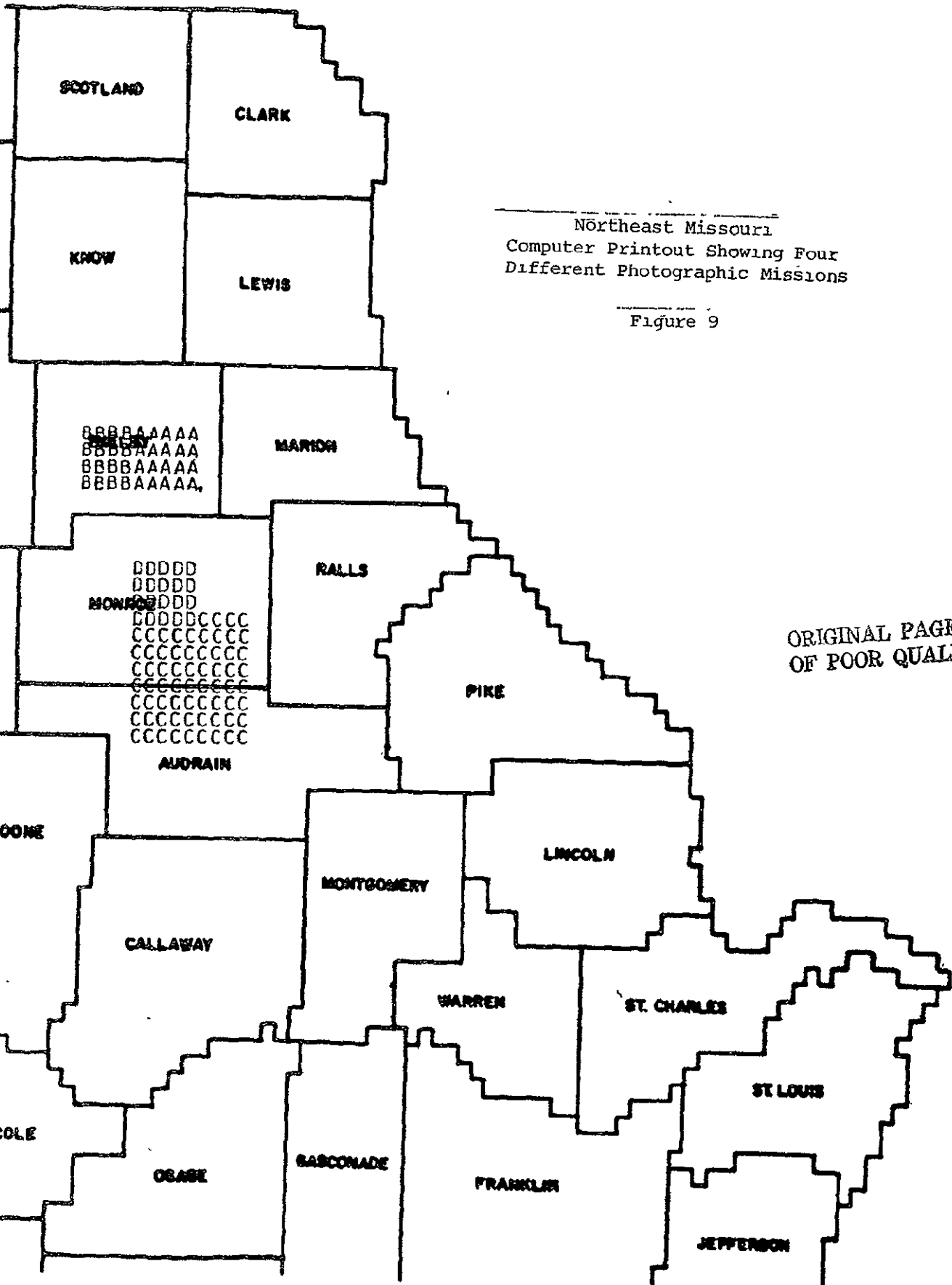

Northeast Missouri
Computer Printout Showing Four
Different Photographic Missions

Figure 9

ORIGINAL PAGE IS
OF POOR QUALITY