

900-800

SATELLITE POWER SYSTEM  
(SPS) MICROWAVE SUBSYSTEM  
IMPACTS AND BENEFITS

(NASA-CR-157951) SATELLITE POWER SYSTEM  
(SPS) MICROWAVE SUBSYSTEM IMPACTS AND  
BENEFITS (Jet Propulsion Lab.) 104 p  
HC A06/MF A01

N79-12558

CSSL 10A

Unclas

G3/44

39421

28 September 1977

Prepared by: Richard M. Dickinson  
Richard M. Dickinson, Radio  
Frequency and Microwave  
Subsystems Section Telecom-  
munications Science and  
Engineering Division

Approved by: Irving Stejneger  
Irving Stejneger, Task Manager  
SPS Impacts and Benefits



JET PROPULSION LABORATORY  
CALIFORNIA INSTITUTE OF TECHNOLOGY  
PASADENA, CALIFORNIA

157105

## DISTRIBUTION

INTERNAL

W. Ackerknecht	161-228
M. Alper	169-527
L. Baker	79-6
R. Bourke	156-203
S. Brunstein	114-B13E
R. Caputo	277-202
R. Chernoff	238-528
R. Dickinson (10)	238-528
E. Finnegan	238-528
C. Finnie	234-737
T. Fujita	122-123
R. Goldstein	122-123
J. R. Hall	238-528
R. Hartop	238-528
R. Kolbly	DSCC182
G. Levy	238-737
F. Livingston	79-6
W. Merrick	238-540
R. O'Toole	79-200
P. Poon	79-6
Darrel Ross	198-220
M. Schwartz	161-213
I. Stein	198-220
R. Stephenson	156-203
V. Truscello	277-202
P. Wiener	198-220
G. Yanow	79-6

NASA HEADQUARTERS

Code NT	R. LaRock
	S. Manson (5)
	H. Calahan
Code MT	J. Disher
Code MTE	R. Johnson
	T. Hagler
Code RX	S. Sadin
Code ECF	S. Fordyce
Code ST	E. Schmerling
	D. Cauffman
Code SB	D. Winter (2)
Code TA	H. Fosque
Code SU	S. Tilford

JOHNSON SPACE CENTER

Code EA4	R. Piland (5)
Code EW4	C. Covington (3)
Code EZ	L. Bell (2)
	H. Benson
Code EJ5	G. Arndt
Code ER	H. Davis
Code SA	O. Garrriott (2)

MARSHALL SPACE FLIGHT CENTER

Code PS04	C. Guttman (5)
Code PD11	K. Fikes

## DISTRIBUTION (contd)

MARSHALL SPACE FLIGHT CENTER (contd)

Code PPO3      W. Rutledge (2)  
Code PS01      G. von Tiesenhausen (1)  
Code ES43      B. Stephens (2)

AMES RESEARCH CENTER

Code 239-1    P. Sebesta  
                  B. Newsom

LEWIS RESEARCH CENTER

Code 49-3      J. Ward (2)

ERDA HEADQUARTERS

Code DSE      J. Madewell  
                  F. Koomanoff (5)  
                  H. Harrenstein  
Code ASGA      R. Kessler  
Code DTO-AES   B. Wachholz  
                  R. Blaunstein  
Code BER      M. Minthorn, Jr.

PRECEDING PAGE BLANK NOT REPRODUCED

## ACKNOWLEDGEMENT

The author wishes to acknowledge the contribution of other members of the Telecommunications Science and Engineering Division to this report. W Ackerknecht wrote the ionosphere section, Rob Hartop contributed heavily to the array antenna pattern section, W. Merrick developed the "woody" rectenna concept and assisted greatly in the rectenna electric system, and Sam Brunstein's assistance is acknowledged in the RFI area.

Among other individuals who proved helpful in the preparation of this report, special thanks is given to J. Ajlaka and V. Ramsey of the Hughes Aircraft Company for their assistance in calculating the phase-controlled beam broadening effects

## FOREWORD

The NASA Office of Energy Programs (OEP) is presently conducting a study of the potential utility of large Satellite Power Stations (SPS) as a possible means to help meet our country's demand for electric power. As part of this study, JPL has been directed to perform an analysis of potential impacts and benefits that would result from the implementation of an SPS.

This report is concerned with the space and earth based ends of the microwave power transmission subsystem that delivers SPS energy to the electrical utilities power grid on earth. The intervening propagation medium near the earth is also considered. The report consists of three major sections dealing with the major subsystem elements, spacecraft transmitting array, propagation in the ionosphere and the ground based rectenna. Radio Frequency Interference (RFI) aspects are discussed in all three sections.

The work is being performed under RTOP 775, under the technical direction and guidance of Mr. Simon Manson of the Solar Energy Division.

## ABSTRACT

The impacts and benefits to society of the microwave subsystem resulting from the developing, construction and operating of a space solar power to earth, electric power delivery system are presented and discussed. The system consists of a fleet of geostationary spacecraft solar collectors and RF converters linked via microwave power transmission beams to multiple ground rectennas. The rectennas collect the microwave power radiated from spacecraft antennas and convert it to dc. The rectennas dc output is further processed to yield either higher voltage dc or ac for interfacing with the electric utility grids.

In the SPS microwave subsystem, the primary benefit (usable energy) is conveyed mainly in the fundamental frequency portion of the RF radiation beam that is intercepted on the rectenna and converted to electric power output. The small fraction of the microwave and other electromagnetic energy that does not end up in the electric utility grid, yields most of the subsystem impacts.

The impacts range from harmonics and noise radiated by the transmitting antenna, through potential interference with ionospheric communications and navigation caused by the power beam heating the ionosphere, to the potential large land area requirements for the rectennas and low level microwave radiation around the rectennas.

Additional benefits range from a very low level of waste heat liberated and lack of atmospheric emissions including noise while operating to having no residual ionizing radiation from the rectenna when it is deactivated.

CONTENTS

I	SPACECRAFT TRANSMITTING ANTENNA . . . . .	1-1
	SUMMARY . . . . .	1-1
1.1	INTRODUCTION . . . . .	1-2
1.2	OPERATING CONCEPT . . . . .	1-2
1.3	ARRAY MECHANIZATION . . . . .	1-8
1.4	IMPACTS AND BENEFITS OF THE TRANSMITTING ARRAY . . . . .	1-9
	1.4.1 Electromagnetic Radiation . . . . .	1-9
	1.4.2 Microwave Beam Radiation Pattern Characteristics . . . . .	1-12
	1.4.3 RFI Considerations . . . . .	1-24
	1.4.4 Occupational Health Effects . . . . .	1-28
	1.4.5 Construction . . . . .	1-29
	1.4.6 Security . . . . .	1-30
	1.4.7 Conclusions . . . . .	1-30
	1.4.8 Recommendations . . . . .	1-32
II	MICROWAVE BEAM PROPAGATION . . . . .	2-1
	SUMMARY . . . . .	2-1
2.1	INTRODUCTION . . . . .	2-2
2.2	THE IONOSPHERE . . . . .	2-2
2.3	EFFECTS ON IONOSPHERIC USERS AND OTHERS . . . . .	2-13
2.4	POWER BEAM EFFECTS . . . . .	2-17
2.5	PILOT BEAM EFFECTS . . . . .	2-19
2.6	CONCLUSIONS . . . . .	2-20
2.7	RECOMMENDATIONS . . . . .	2-20
III	RECTENNA ARRAY . . . . .	3-1
	SUMMARY . . . . .	3-1
3.1	INTRODUCTION . . . . .	3-2
3.2	THE RECTENNA ARRAY . . . . .	3-4

CONTENTS (Cont'd)

3.2.1	Functional Detail . . . . .	3-4
3.2.2	Physical Form . . . . .	3-5
3.2.3	Operations . . . . .	3-8
3.3	IMPACTS AND BENEFITS . . . . .	3-10
3.3.1	Land Use . . . . .	3-10
3.3.2	Radio Frequency Interference . . . . .	3-15
3.3.2.1	Beam Pointing . . . . .	3-15
3.3.2.2	Propagation Conditions . . . . .	3-16
3.3.2.3	Conditions at the Rectenna . . . . .	3-18
3.3.2.4	Harmonic Reradiation . . . . .	3-21
3.3.2.5	Other RFI Sources . . . . .	3-21
3.3.3	Materials Requirements . . . . .	3-22
3.3.3.1	The Rectenna Element and Instrumentation . . . . .	3-23
3.3.3.2	The Subarray . . . . .	3-24
3.3.3.3	Auxiliary Facilities and Alternate Loads . . . . .	3-26
3.3.3.4	Maintenance . . . . .	3-29
3.3.3.5	Materials List . . . . .	3-29
3.3.4	Occupational Health Effects . . . . .	3-31
3.3.5	Construction . . . . .	3-33
3.3.6	Security . . . . .	3-34
3.3.7	Miscellaneous . . . . .	3-35
3.3.8	Deactivation . . . . .	3-37
3.4	CONCLUSIONS . . . . .	3-37
3.5	RECOMMENDATIONS . . . . .	3-39
IV	REFERENCES . . . . .	4-1

8



## SECTION I

## SPACECRAFT TRANSMITTING ANTENNA

## SUMMARY

The impacts and benefits of the transmitting antenna portion of the SPS microwave subsystem are presented and discussed. The system benefits generally appear on the earth end of the energy transfer link. A number of significant impacts occur or originate at the dc to RF conversion or spacecraft end of the energy link. The highly nonlinear process of converting dc to RF power with high efficiency, also leads to the generation of electromagnetic radiation at both lower and higher frequencies. The magnitudes and angular distribution of these radiations are the subject of this section. These impacts, in the form of electromagnetic radiation throughout the spectrum from very low frequencies on up to optical frequencies and beyond, are most significant because of the SPS spacecraft visibility from almost an entire hemisphere of the earth.

The distribution of energy around the power array is of concern as an occupational health hazard during maintenance and repair. Also, the dangers of accidental beam testing in low earth orbit (LEO) and normal beam operation and testing in geostationary orbit (GEO) are discussed as potential impacts.

The development of high efficiency dc to RF converters may benefit earth applications of microwave power such as occur in consumer microwave ovens and industrial process heating by microwaves.

## 1.1. INTRODUCTION

The impacts and benefits to society from constructing and operating the RF power transmitting portion of an SPS are to be discussed. The transmitter is a dc to RF converter and RF radiating antenna containing phase steering and other electronics, that is linked to the solar collector portion of the spacecraft via a rotary interface. A brief technical discussion of the proposed operating concept of the transmitting array will be followed by a description of the mechanization, from which the impacts and benefits may be derived.

## 1.2. OPERATING CONCEPT

Because of the economies of scale in SPS and because of the need to operate at relatively long wavelengths that are nearly lossless when propagating through the earth's atmosphere, the proposed transmitting antenna is about 1 km in diameter (e g., Ref. 1). The production of a highly efficient beam of energy, (see Fig. 1-1 for nomenclature) at the contemplated design frequency of 2.45 GHz, with low sidelobes and pointed toward the rectenna with high accuracy, requires in effect that an accurate, uniform phased sheet of RF current be maintained over the km aperture. The performance resulting from the likely state-of-the-art in generating and maintaining the resulting surface figure required of a conventional shaped reflector type of antenna of 1 km diameter would probably be severely degraded, since the equivalent Root Mean Square (rms) surface error should not exceed about 2mm'. In addition, this figure would have to be maintained for the typical electric power utility design lifetime of 30 years. This would be difficult and would be made more so by the thermal cycling due to eclipses that occur annually during the equinoxes. However, by use of an array of many small RF current sheet subarrays, the antenna may be mechanically arranged to periodically relieve stresses at the interfaces between subarrays. Electronics (Ref. 2) can then be used to compensate for the resulting RF phase path length errors due to subarray structural deflections and other RF errors. (Fig. 1-2)

An array composed of small diameter reflector antennas is unsatisfactory because the individual tapers across the apertures, combined with the interstices, lead to a partially filled array with loss of main beam efficiency

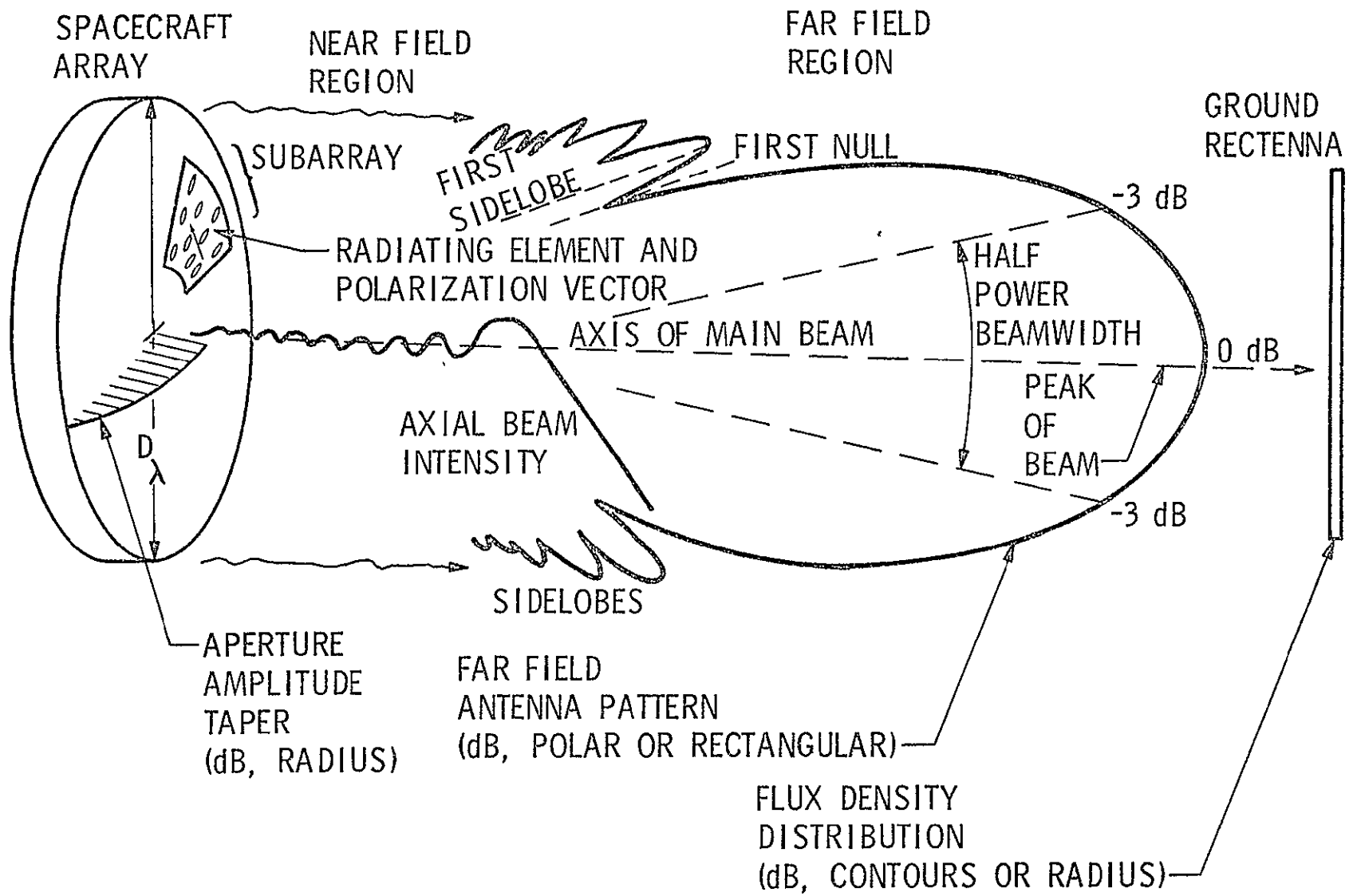

Fig. 1-1. Antenna characterization index

due to the inevitable grating lobes. Grating lobes are spatial repetitions of the main array pattern that occur because there are a multiplicity of angular directions off axis of the array wherein the phase contributions from each of the subarrays add up. The levels of the grating lobes are determined by their order or position from the main beam axis, which is a function of the subarray pattern and subarray aperture efficiency, the subarray spacings, and the electronic scan angle of the array. Grating lobes will be present even with the beam electronically set for pointing on axis, due to the angular tilt and displacement of each of the subarrays as stresses are relieved in the overall array. The beam efficiency of the overall array is reduced by the ratio of the filled to the available aperture areas

Thus, an array of flat planar subarrays which tile the antenna plane and possess fixed or quantized power levels, is proposed as the technique for generating the desired tapered aperture distribution necessary for high beam efficiency and low sidelobes and grating lobes. Figure 1-3 shows the optimum RF power density distribution or "taper", across the array aperture that is required to achieve a certain design level of beam transmission efficiency. However, it may be necessary to employ a more severe taper in order to reduce the level of sidelobes in the array pattern (Fig. 1-4). This would result in a larger than optimum diameter rectenna for the same beam transmission efficiency due to the wider main beam width.

Each of the subarrays must be individually phase controlled with precision in the range of 10 degrees rms or less in order to achieve the desired beam forming and pointing resulting from an equivalent continuous uniform-phase sheet of RF current. This is to be achieved by use of a pilot beam low level RF signal launched from the earth near the center of the rectenna.

The pilot beam signal is received at each of the thousands of RF power radiating subarrays on board the satellite. The arrival time of the pilot signal at each subarray is compared to an internal reference signal. The reference signal is distributed via a special phase-compensated, path-length correction scheme throughout the array. The compensated reference distribution system is required to assure that each of the subarrays radiates its power beam contribution with the same effective static phase (modulo  $2\pi$ ) as the central reference subarray. A phase trim sequence for each individual subarray will be

# ELECTRONIC COMPENSATION OF STRUCTURAL DEFLECTIONS IN A LARGE POWER TRANSMITTING ANTENNA via A PILOT BEAM STEERED RETRODIRECTIVE ARRAY WITH A SELF-COMPENSATING PHASE REFERENCE DISTRIBUTION SCHEME

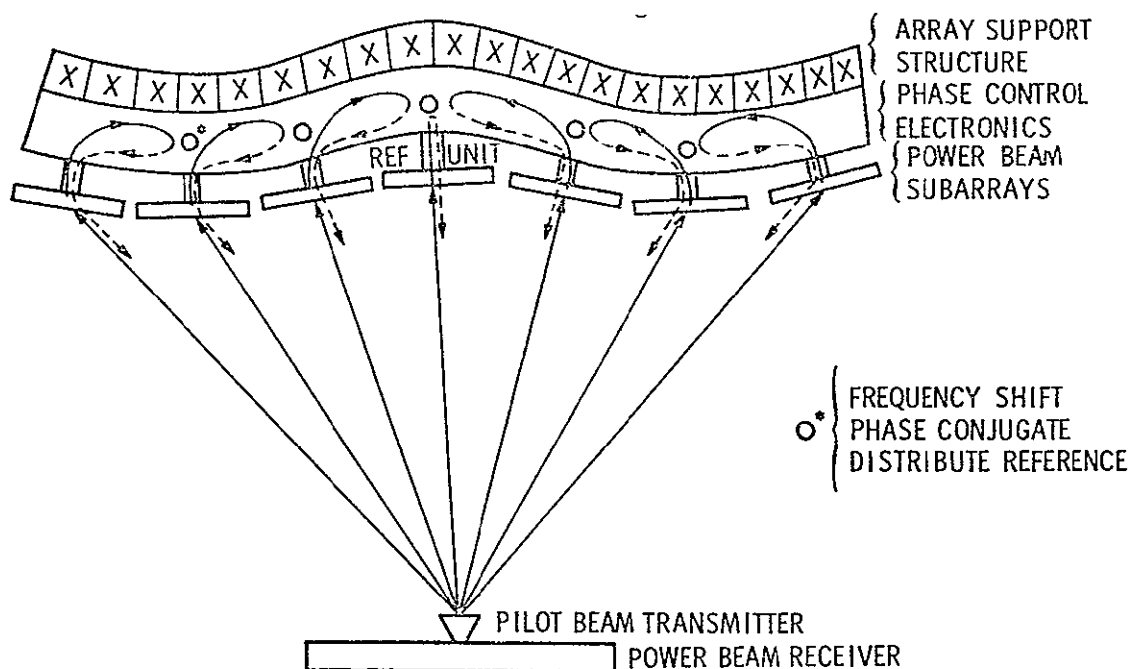

Fig. 1-2. High power microwave transmission "Floppy" power array

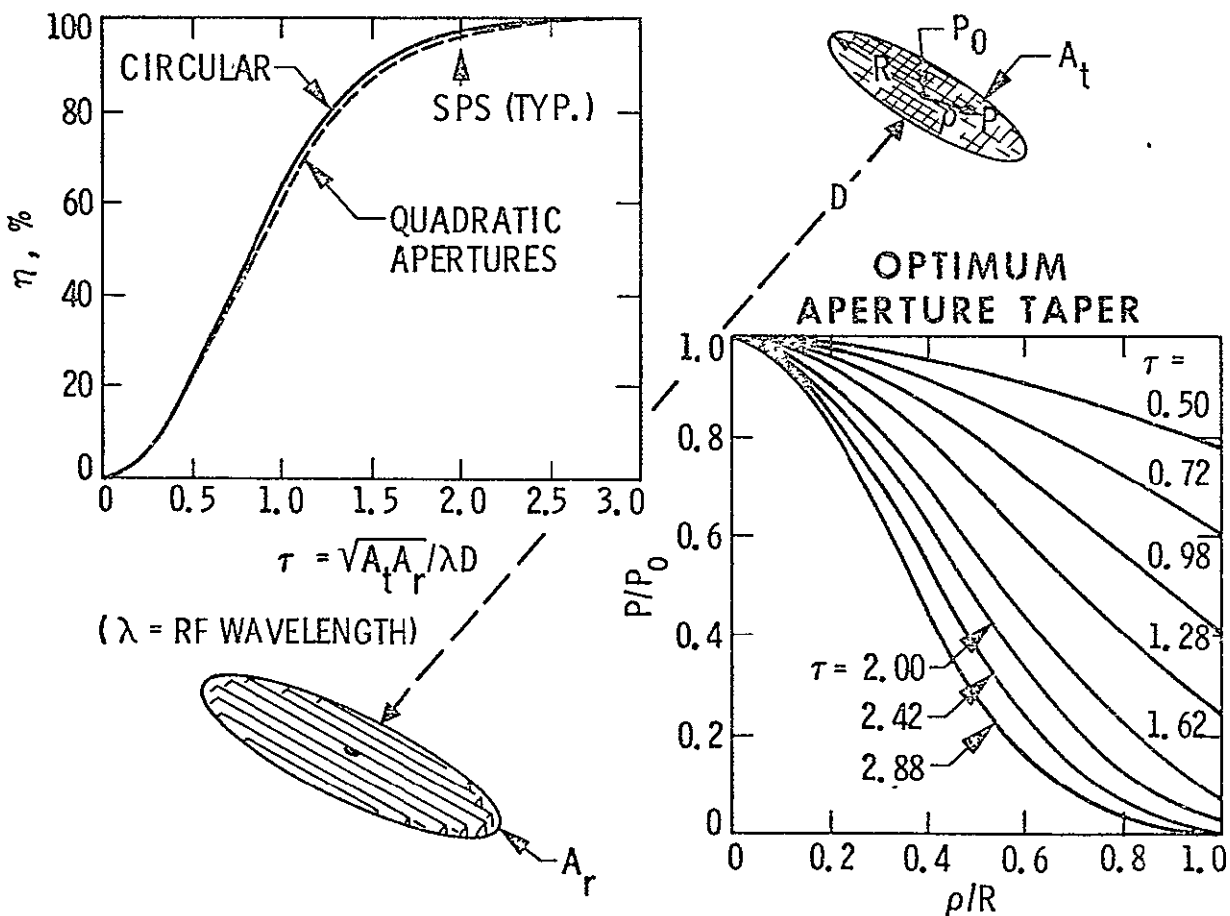

Fig 1-3 RF power beam transmission efficiency (after Goubau and Schwering)

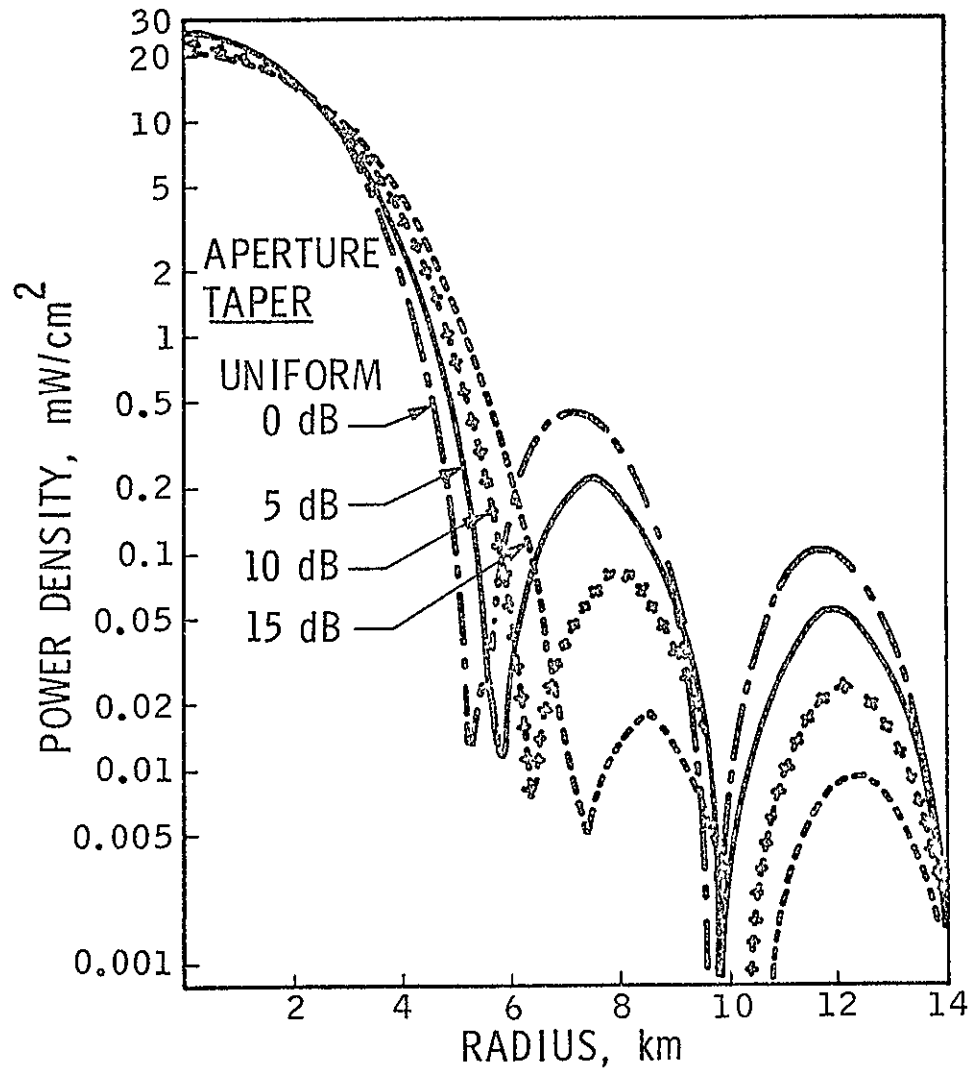

Fig. 1-4. Rectenna power density vs array aperture taper

required to initially set and then to periodically check the maintenance of the required condition of "identical" static phase at the rectenna. The frequency and accuracy required of this action is unknown at present, and depends upon system requirements and component capabilities. The static phase reference distribution scheme must be independent of path length changes such as are induced by structural deflections or thermal changes and aging of transmission lines. This requirement is the most significant change from previous retro-directive array practice, in that up until the magnitude of array size and order of precision of this requirement, the relatively small phase reference transmission-distribution lines could be maintained with brute force methods - lots of steel, concrete and air-conditioning. New lightweight techniques are required for the spacecraft.

Any resulting phase differences between the received pilot signal at each subarray and the reference signal at each subarray (which may be due to spacecraft station keeping motions, structural flexing or thermal changes in the array figure, attitude control limit cycling or internal electrical RF path length drifts) are adjusted to correct the individual phase of the RF power beam radiated from each subarray. The phase comparison and phase correcting process is termed phase conjugation, in that received phase lead errors, which occur when the pilot signal is compared to the reference, are turned into phase lags (the conjugate) or vice versa, which are then applied to the retransmitted power signal.

In order to prevent the array electronics from self oscillating, the pilot and power signals must be separated in frequency. The location of the frequency separation or diplexing filter point should be as far downstream or deep into the subarray RF section as possible. This is because of the extreme phase precision required of the array. As much as possible of the same common RF plumbing-antenna radiator, power distributing waveguides, harmonic suppression filters, switches, etc - should be traversed both by the low level pilot signal upon reception, as well as by the high-power beam signal, so as to track out all common path length "electrical" as well as "mechanical" phase changes. Feedback type phase comparison and phase shifter controlled compensation loops will more than likely be required to be placed around all of the

high-power dc to RF converters to assure that the output RF phase is maintained (modulo  $2\pi$ ) relative to the desired conjugated phase throughout the devices lifetime in orbit.

Since most RF components tend to have slightly different characteristics at different frequencies (dispersion) it is desirable to have the frequency of the pilot signal close to the power signal frequency, so as to reflect consonant path length phase changes when they occur. However, because of noise generated by the dc to RF converters along with the power signal, the pilot signal-to-noise ratio is degraded in-close to the carrier. Additionally, the pilot beam signal must be coded with modulation to prevent any potentially adverse adaptation of the SPS or to prevent surreptitious diversion of RF power output in order to avoid paying the utility charge. The modulation requires a finite bandwidth around the pilot tone and it must be separated from the power converter noise. The resulting engineering design compromise will be difficult to resolve. Additionally, certain mechanizations of the retrodirective scheme will squint the power beam relative to the pilot beam received direction (that is an angular separation or offset in pointing), while others will not.

In summary, the operating concept of the SPS transmitting antenna is one of an array of flat subarrays tiling a plane 1 km in diameter. By use of a pilot beam from the rectenna to steer and phase the retrodirective subarrays, an effective uniform phased, sheet of RF current with a tapered distribution of amplitude across the circular disk is obtained, that is somewhat independent of the first order supporting structure deflections.

### 1.3. ARRAY MECHANIZATION

Current concepts of the array tend toward low power, 5 to 50 kW passively radiation cooled dc-RF converters, either amplitrons or klystrons, respectively. The RF radiating antennas are slotted waveguides. A subarray, that is a uniphase assemblage of converters and RF radiating antennas fed from one pilot receiver and phase conjugator, is 10 to 18 m square. The dc supply voltages from the rotary joint power processor interface range from 20 to 40 KV. Aperture amplitude tapers of 5-10 dB and pilot beam frequency separations from the power carrier of 10-100 MHz are considered. The array back-up support



structure ranges in depth of section up to 40 m. The RF current radiators are excited by applying the dc distribution voltage (and RF drive in the case of the amplifiers) to banks of subarrays in a sequenced fashion

#### 1.4 IMPACTS AND BENEFITS OF THE TRANSMITTING ARRAY

##### 1.4.1. Electromagnetic Radiation

Figure 1-5 is an idealized and simplified characterization of the distributions of electromagnetic radiation, throughout the spectrum, around the SPS spacecraft transmitting array. The actual angular distributions and absolute magnitudes are obviously a function of the detailed system design and configuration. The spacecraft antenna is a wide spectrum source, and because of its visibility from nearly a hemisphere, the potentially impacted populace and equipment are enormous (Fig 1-6).

The potential impact sources are current distribution switching transients, the desired power beam, the undesired harmonics and noise, the waste thermal infrared heat, sunlight reflections, and the X-rays produced by the deceleration impacts of RF and dc accelerated electrons in the converter electrodes or structure. Those impacted by the extraneous radiation are other spacecraft, earth based communications, the biosphere, astronomers, nocturnal navigators and support or maintenance personnel and equipment. Obviously, the RFI distribution changes depending upon the quantity of subarrays turned-on as well as whether or not they are phased and with what degree of accuracy! Hence the antenna pattern variations that occur during turn-on and with subarray failures and during turn-off will create impacts as will the transients associated with switching such large magnitudes of current, which tend to excite portions of the spacecraft structure.

Due to the high level of biasing of metal-oxide-metal nonlinear junctions by the power beam, additional RF frequency signals such as the pilot signal and any command and telemetry signals, can generate intermodulation products (IMP), which are new frequency signals resulting from mixing (Ref 3). Although the IMP levels are low due to the inefficiency in their generation, they may be radiated from a platform with a distinct positional advantage in

1-10

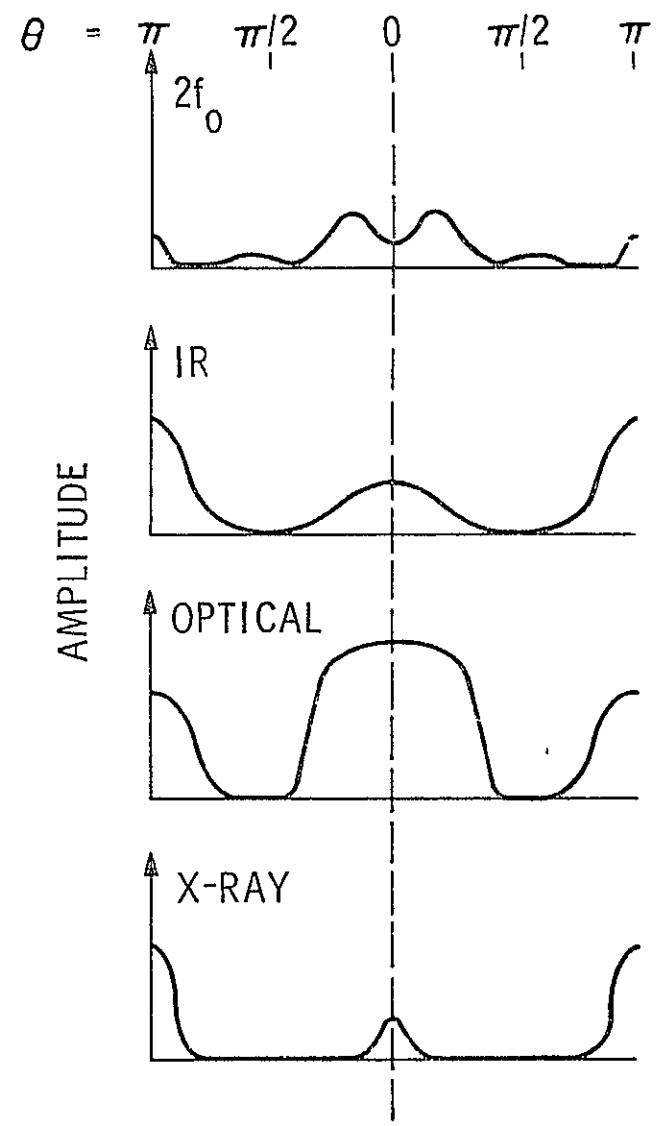
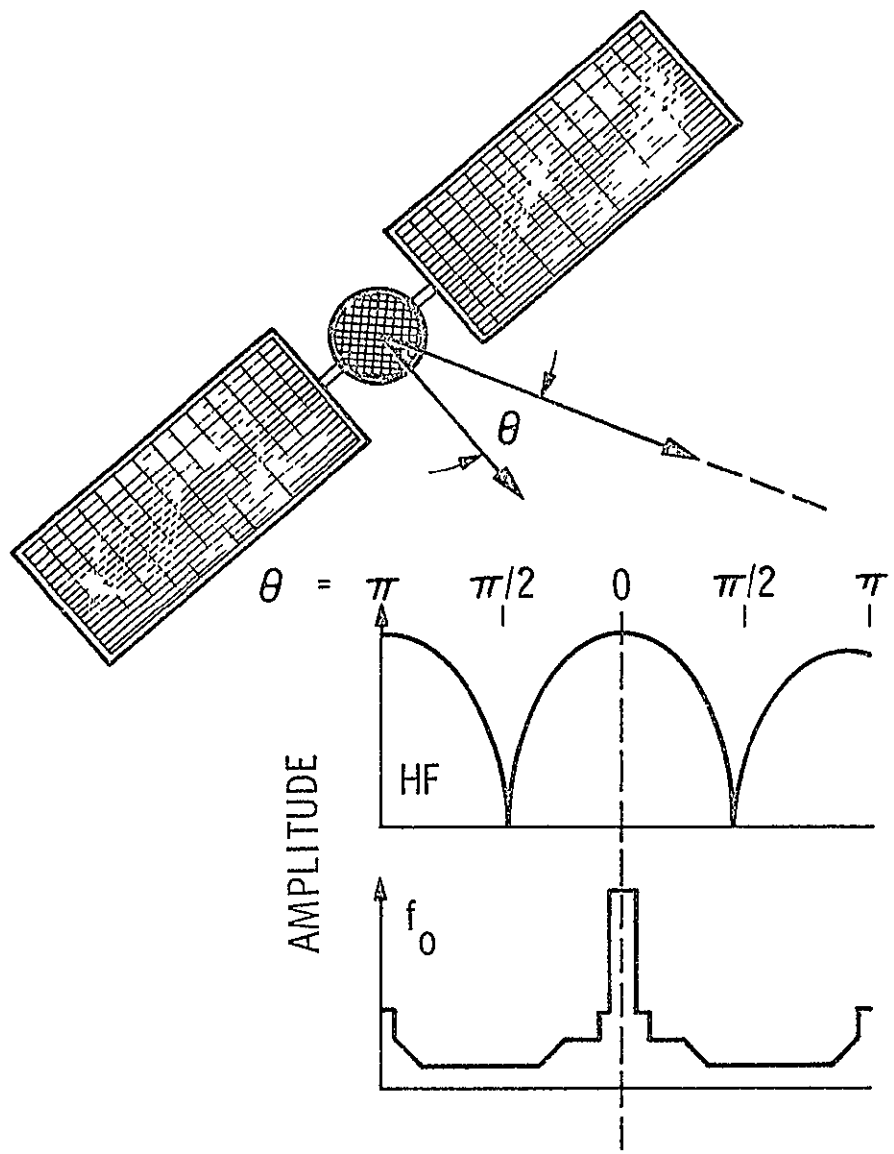
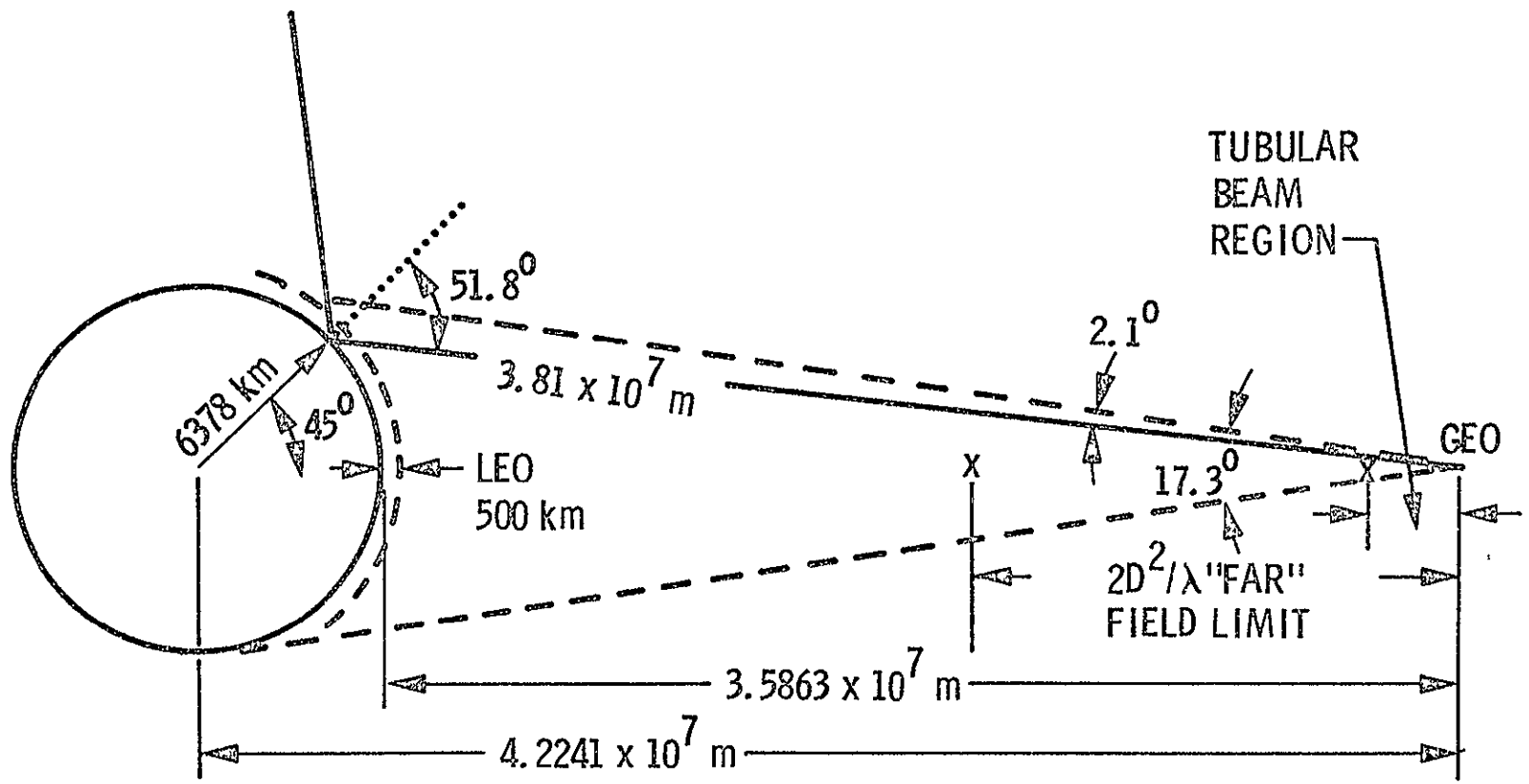

Fig. 1-5. SPS electromagnetic radiation distributions

11-11



900-806

Fig. 1-6. Satellite power system typical geometry

terms of impact RFI potential. IMP impacts can occur both on the spacecraft and on the ground.

In addition to the arcing that will occur during switching of dc, there will probably be arcing in the waveguide assemblies due to multipacting breakdown upon initial turn-on of the array and subsequently. Figure 1-7 shows the approximate rms initiation breakdown voltage for various products of frequency and electrode separation, for parallel plate electrodes. Although the fringing fields in slots can withstand a somewhat higher voltage before breakdown, Fig. 1-7 shows that wide slots will be necessary to minimize this RFI contributor.

#### 1.4.2 Microwave Beam Radiation Pattern Characteristics

The purpose of this part of the impact and benefit investigation is to describe with reasonable accuracy the microwave radiation pattern of the SPS antenna array with the following assumptions.

Diameter	1 KM
Frequency	2450 MHz
Power	6500 MW
Distribution	Gaussian, 10 dB taper

For certain calculations, it was further assumed that the practical imperfections consisted of an amplitude error of 1 dB independent of failures, 2 percent random failures of the individual 10 meter subarrays, and a phase error of 10 degrees RMS (Ref. 1).

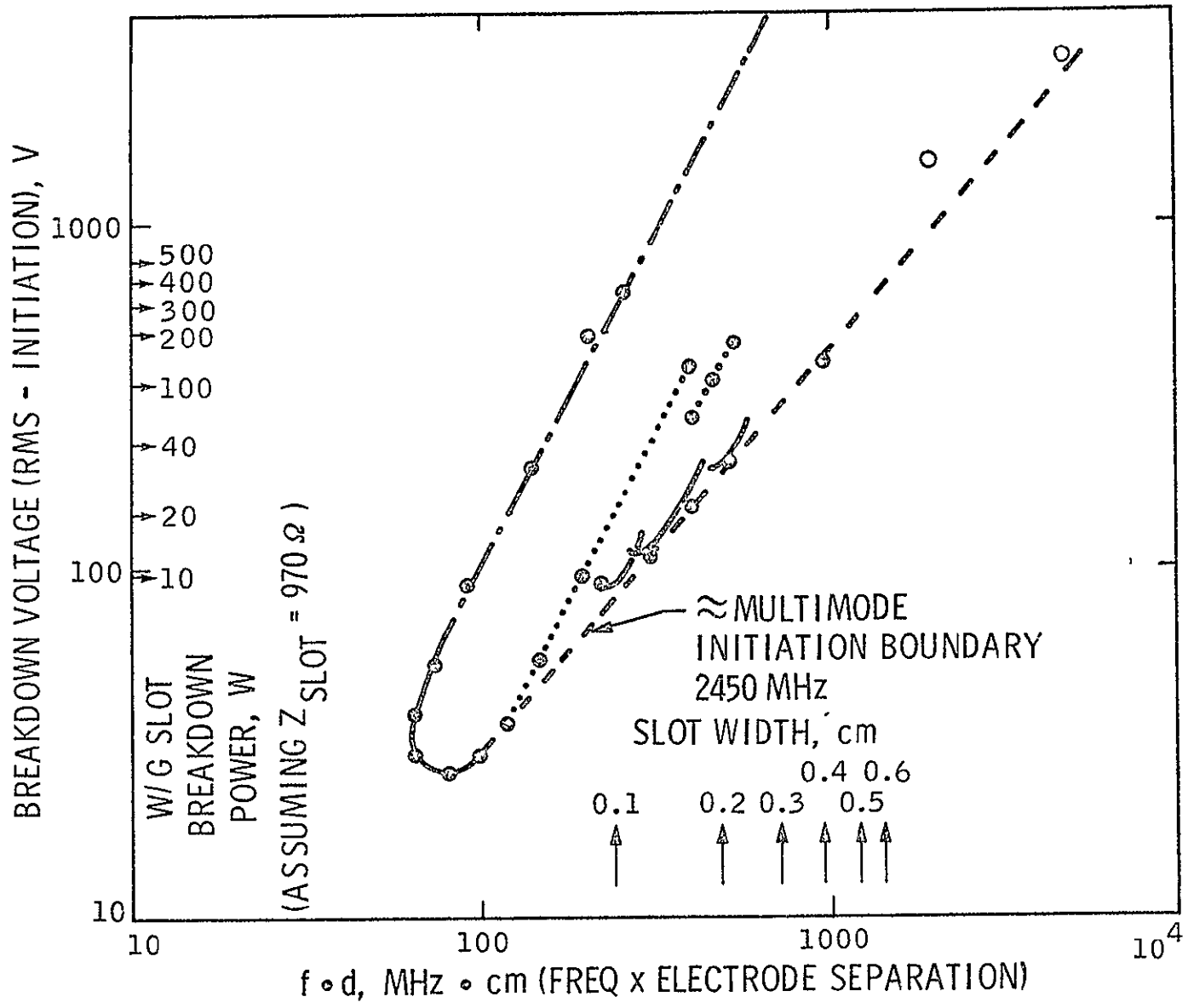

Fig. 1-7. SPS waveguide multipacting breakdown

Under these conditions the near field of the array is shown in Fig. 1-8. Here, the first curve describes the axial power density, with a taper that closely approximates the true Gaussian. It is seen that the power density oscillates about the aperture density of about  $21 \text{ KW/M}^2$  until it exceeds this value by some 60 percent. It then decays rapidly and falls into the inverse-square law curve at the far-field distance of 16,000 KM.

The second curve is an attempt to illustrate the behavior of the nearfield at the edge of the main beam. Here, uniform illumination has been assumed to show that the ripple is greatly reduced and that the edge density is lower even without taper. If the 10 dB Gaussian taper were factored into this curve, the density would be very low compared to the beam axis. Thus, the near-field pattern of the antenna is not quite the "tube" of flux that is frequently pictured. Instead the power density increases rapidly but smoothly as one crosses the "edge" of the main beam, with the axial peak strongly dependent on the exact distance from the array if within about 4000 KM of the antenna.

Turning to the far-field characteristics, the pattern of the array is plotted in Fig. 1-9 to present all the major features of the pattern and to compare them with the generalized International Radio Consultative Committee (CCIR) radiation pattern applying to large reflector antennas (Ref. 5). Except

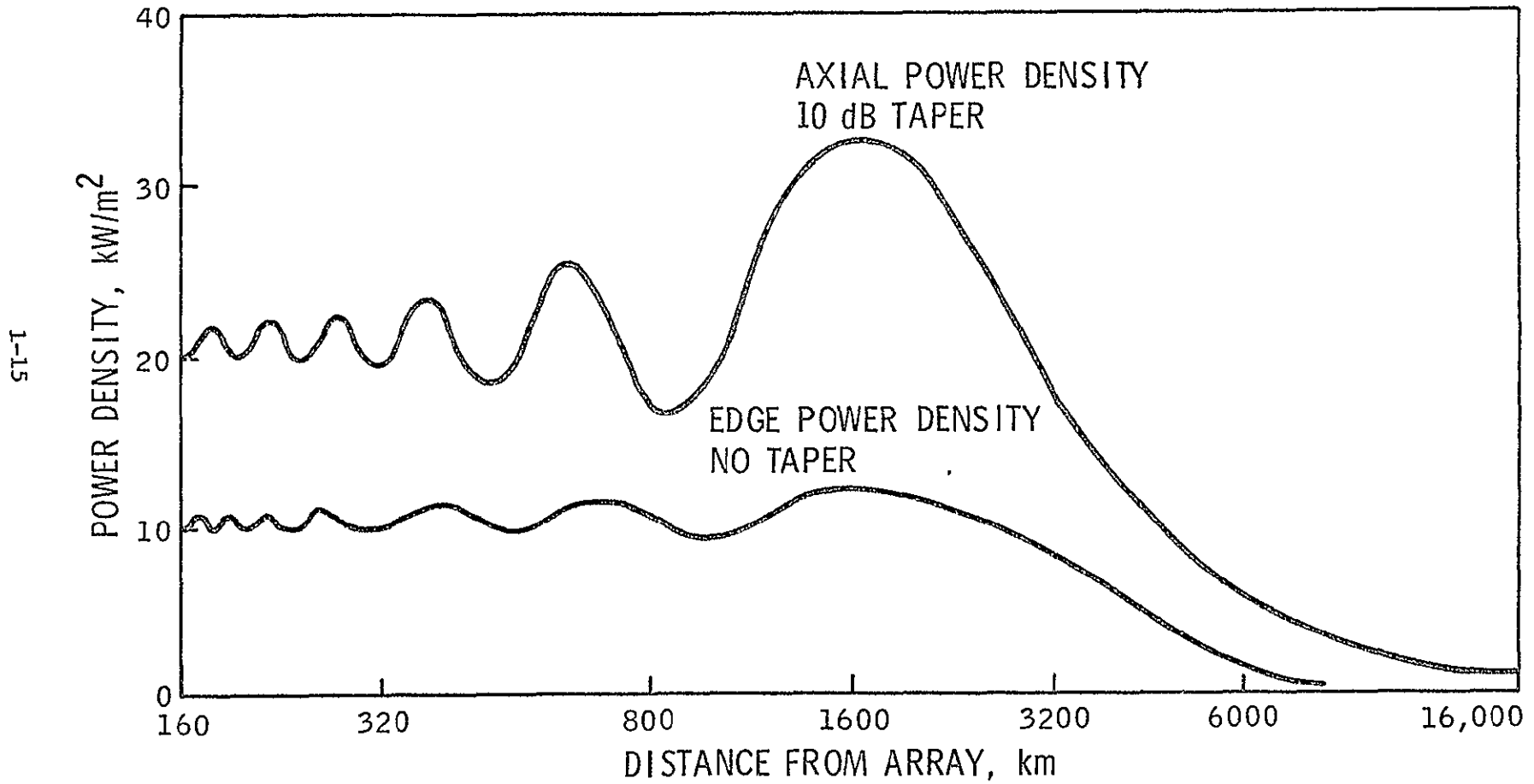

Fig. 1-8 SPS array near-field.

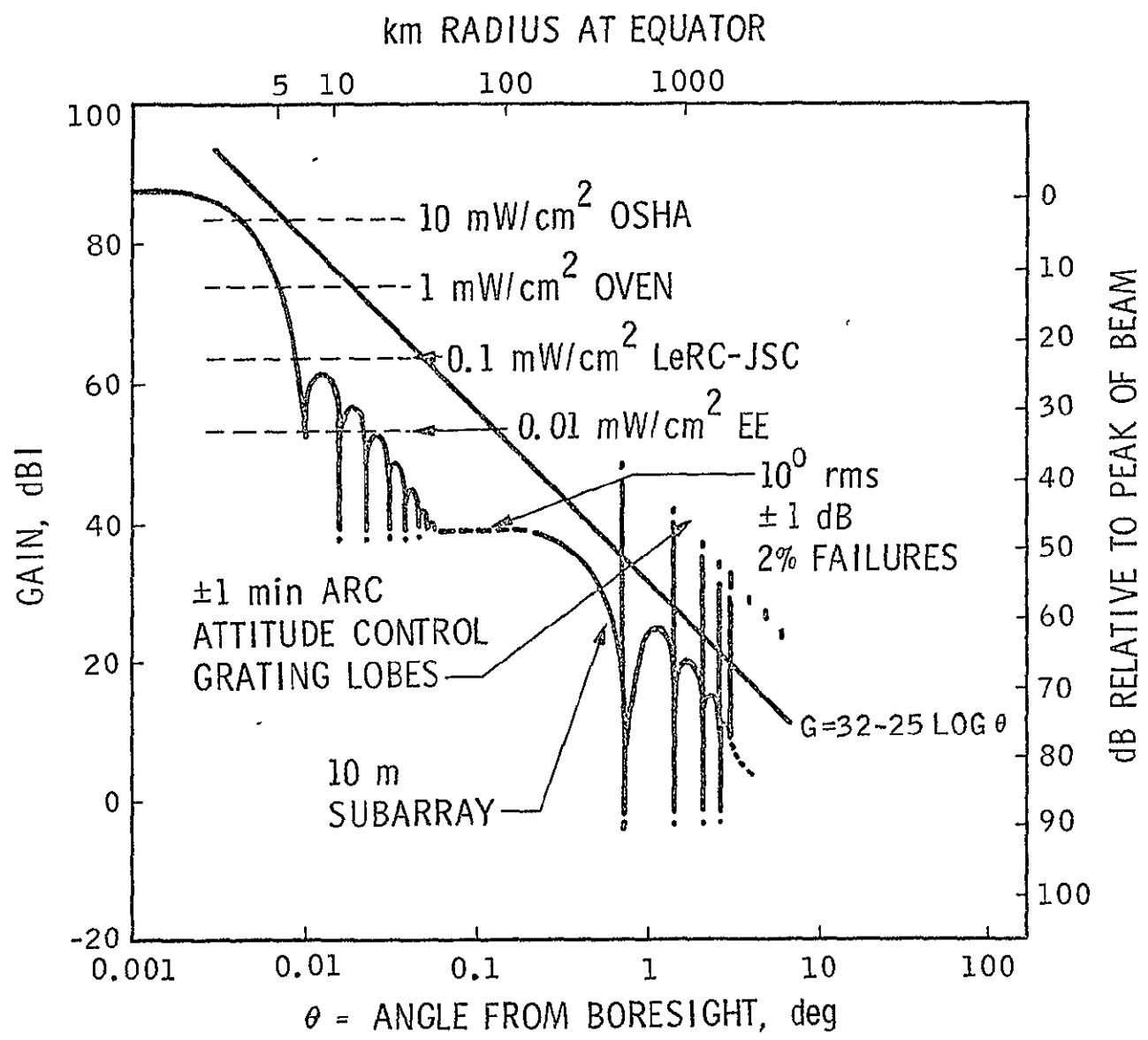

Fig. 1-9. SPS 10-dB taper array pattern.



for the grating lobes, the SPS pattern falls everywhere below the CCIR pattern. The latter cannot be used to describe in a simple manner the safe sidelobe envelope of the SPS pattern because of the grating lobes.

Note that this type of plot clearly shows that the gain of the antenna represents radiated energy that is "borrowed" from the region between 20 and 180 degrees from boresight. On the graph this is a very small area; in space it is the majority of the solid angle surrounding the antenna. Another way of describing it is that out to some 10 degrees, depending on the exact sidelobe structure, the antenna still has gain. Past this point, the radiation is below that of an isotropic radiator.

The major features shown in the curve are:

1. The main beam (to about 0.01 deg);
2. The near sidelobes (to about 0.07 deg);
3. The null filling (Ref. 6) due to subarray phase errors (to about 0.2 deg);
4. The subarray pattern that allows the sidelobes to decay once more (to 0.7 deg);
5. The far sidelobes (past 0.7 deg) and grating lobes.

The null filling in the region of 0.2 deg is intended to be representative. The actual antennas will have somewhat individual structures in this region depending upon their precise errors. Also, no attempt has been made here to calculate the radiation pattern beyond a level of -80 dB from the peak gain. At this level, the exact structure of the pattern will be highly dependent upon a number of details such as the exact subarray size and slot design, the cross-polarization characteristics, harmonics, the degree of surfacewave and edge current control, and varying reflections off the SPS solar panel structure.

Figure 1-10 shows the focused array beam power pattern distribution characteristics for the array at GEO and the considerations relative to LEO potential characteristics of the beam if it were accidentally or adversely adapted to turn-on and be pointed toward the earth from an altitude of 500 km. In LEO, the unfocused beam will spread the peak flux density down to about 18 mW/cm<sup>2</sup>. Were the subarrays to be provided the proper pilot signal or some other accidental focusing stimulus, the peak flux density could reach about 24 W/cm<sup>2</sup>, which is the approximate limit determined by atmospheric breakdown at about 45 km altitude. (Without the upper atmosphere breakdown limit, the peak flux density at the earth's surface could approach 240 W/cm<sup>2</sup>. At the earth's surface for standard temperature and pressure, the theoretical breakdown limit is 1.2 MW/cm<sup>2</sup>!) Thus, the impacts of accidental or adverse adaptations of the SPS transmitting array are potentially enormous in LEO. From GEO, the array cannot be focused any finer on the earth's surface, thus the peak flux density for one SPS array in GEO will not be able to exceed the designed 22 mW/cm<sup>2</sup>.

The ability of the SPS to overcome one potential hazard associated with LEO turn-on, that of ionospheric saturation was determined. Because the near-field power density is so high (refer again to Fig. 1-10), LEO turn-on in a focused mode would not appear feasible because of ionospheric breakdown (Ref. 7). Thus it is prudent to ask what might be done to the beam to allow full power radiation.

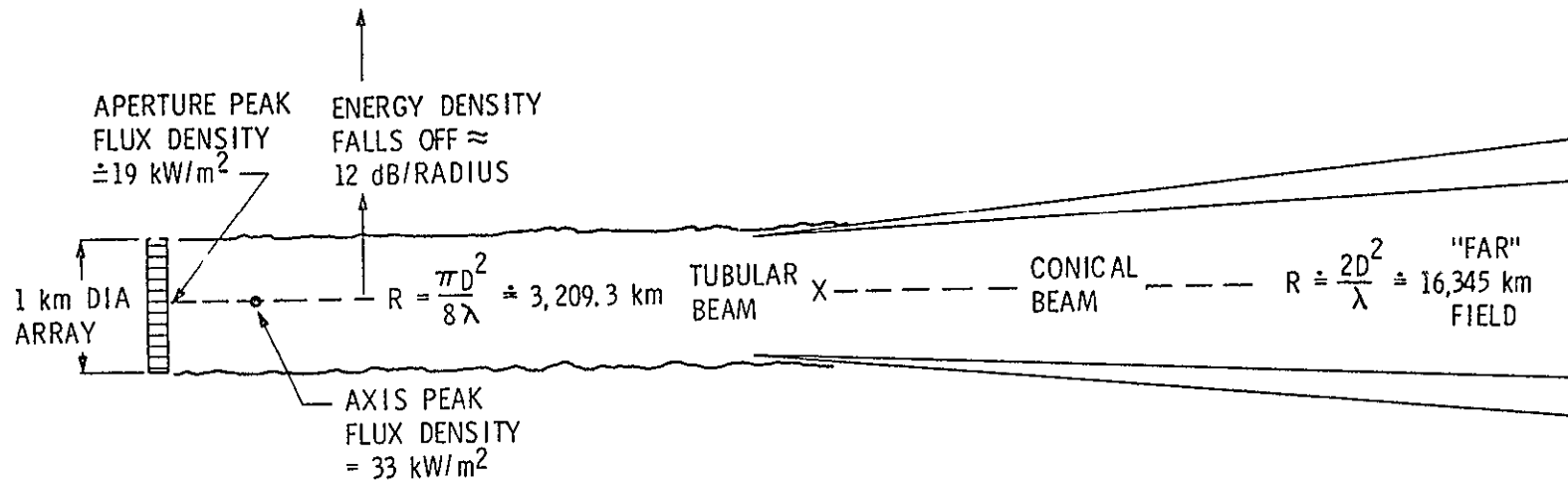

## LEO ARRAY CONSIDERATIONS

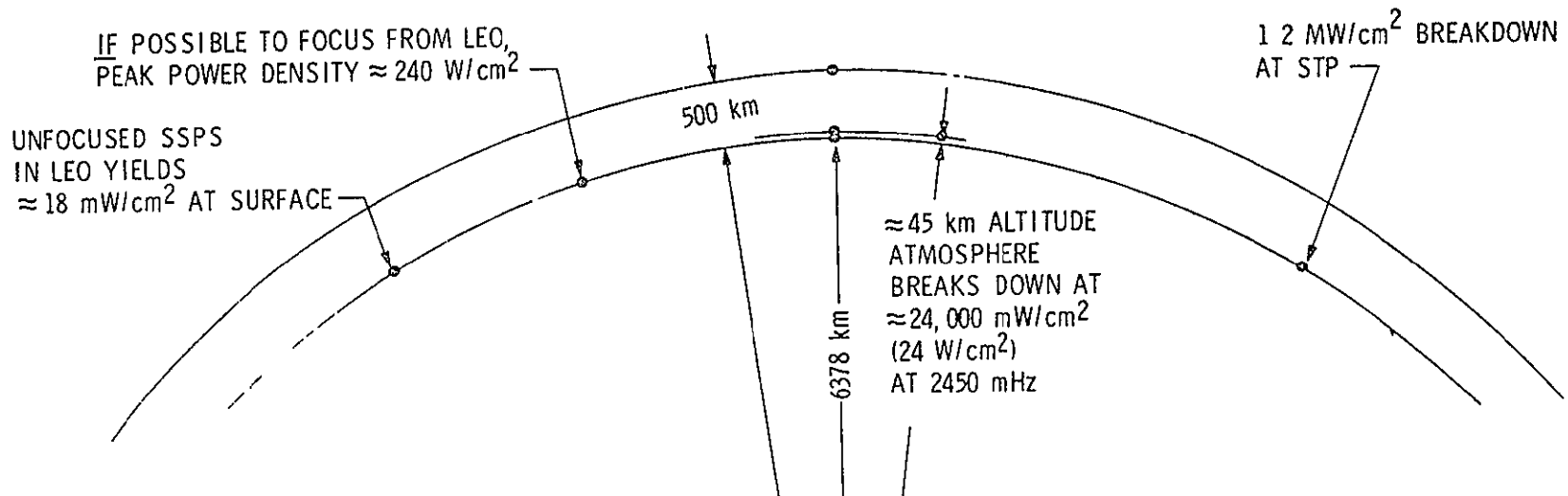

Fig. 1-10. LEO focused array near-field characteristics and LEO array considerations

Techniques for beam-broadening might involve mechanically tilting the subarrays so that each points in a slightly different direction. This can also be accomplished electrically by introducing progressive linear phase slopes over the subarrays. Also, if a curved phase front across the array can be sufficiently well approximated, the radiation can be made to appear as though it came from a curved array. Such a curved array can produce a relatively broad beam without a severe loss in efficiency. Let us assume that we wish to lower the power density to about  $23\text{mW}/\text{cm}^2$ , which we know can penetrate the ionosphere. Then we wish to decrease the near-field power density from  $21\text{KW}/\text{M}^2$  to  $23\text{mW}/\text{cm}^2$ , or a factor of approximately 100. Thus, the beamwidth must be increased 10 times or from 0.008 deg. to 0.08 deg. If the beam can successfully be broadened by this much, then we can obtain any intermediate power density that is desired, up to the limit of the ionosphere for a given set of transmission criteria.

The approach taken was to calculate the pattern resulting from the array when the apparent phase center is some finite distance behind the array. Thus in Fig. 1-11 we imagine a phase-control source located behind the array so that the array subtends a full angle of 0.08 deg. (Imagine that the array has detectors over its rear surface which supply the signal to the amplifiers for re-radiation off the front of the array. In practice, the resulting hyperbolic phase distribution across the planar array would be internally generated by appropriate phase delay devices in the pilot beam receiving and control system). The main beam for this particular case is shown in the Figure to have a half-power beamwidth of 0.055 deg. with less than 2 dB ripple.

A larger phase angle, and thus a greater curvature of the phase front produces a wider beam. Thus in Fig. 1-12, with a phase angle of 0.10 deg. the beam has been broadened to 0.074 deg. with only 1.5 dB ripple. This amount of broadening is enough to allow the beam to penetrate the ionosphere regardless of range. Thus it appears certain that with proper phase control mechanisms within the array, the beam can be efficiently controlled to any desirable beamwidth from 0.008 deg. to at least 0.074 deg.

In summary, an overall view of the principal characteristics of the microwave radiation pattern of the transmitting array has been presented. It has been shown that it may be practical to control the width of the main beam so

1-21

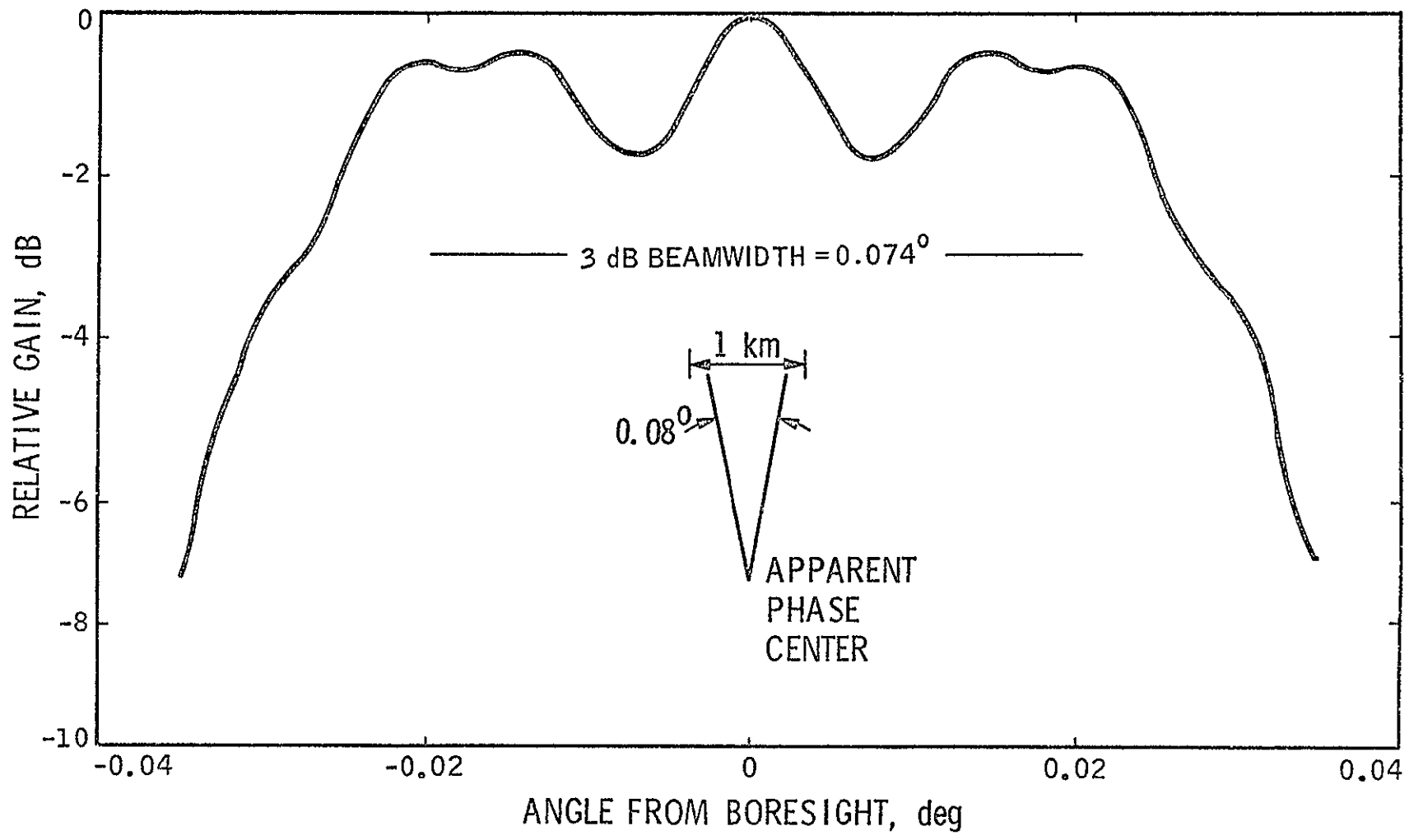

900-800

Fig. 1-11. SPS array beam broadening by quadratic phase control

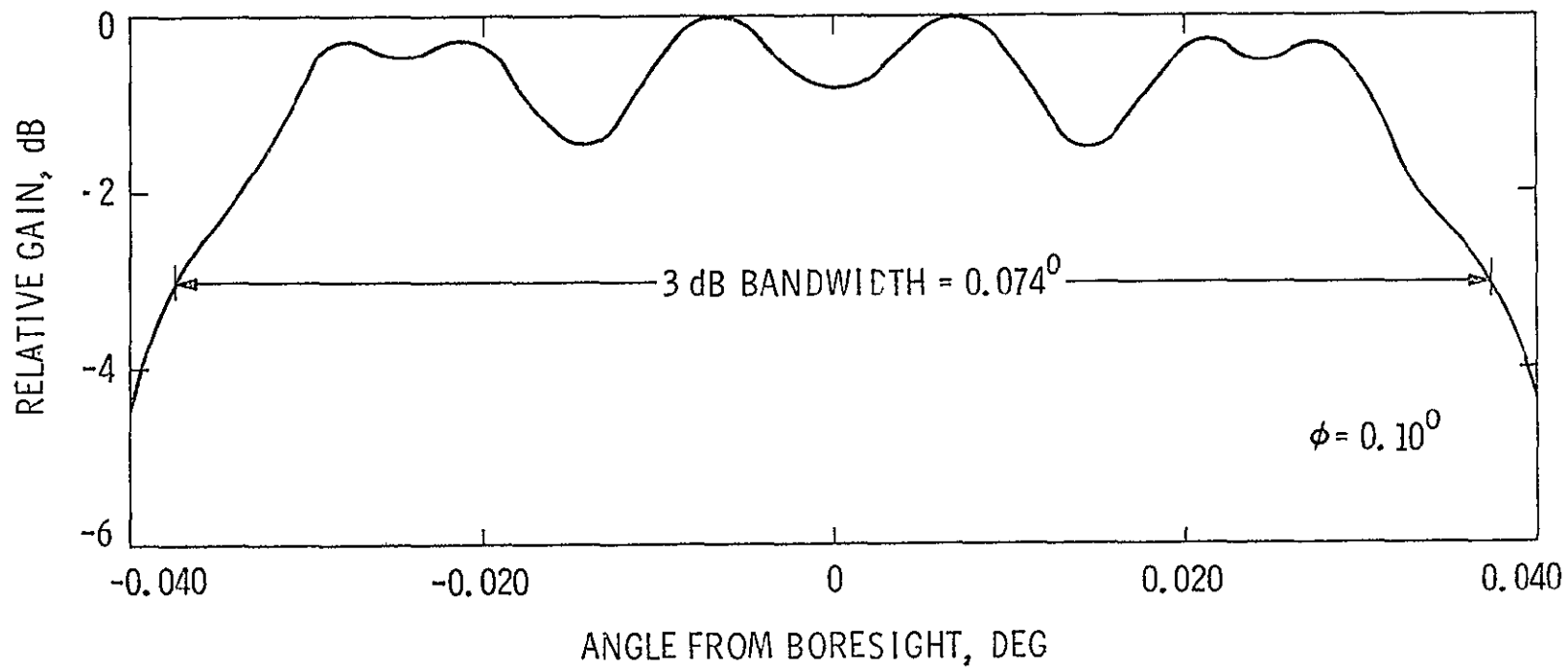

Fig. 1-12. Array beam broadening by quadratic phase control

that full power transmission in LEO could be available. The ramifications of this result should be explored in a future study.

Without extensive computer analysis it has not been possible to examine the fine details of the radiation pattern. Since the exposure of maintenance personnel in the vicinity of the satellite is dependent upon a careful understanding of these details, future effort should involve extensive computer time and expert programming assistance to permit the precise calculations of far sidelobes and backlobes, taking into account structural scattering, harmonics, polarization, surface wave effects, edge currents, leakage, and various failure modes. Some consideration should be given to scale modeling the array and experimentally verifying some of the calculations.

### 1.4.3 RFI Considerations

The SPS operating frequency and conditions must be chosen to minimize the RFI caused to existing services. Not only is this a matter of technical desirability, but also of national and international regulation.

Currently, it is felt that advantage can be taken of frequency allocations made for industrial, scientific, and medical (ISM) use. These allocations are contained in the International Radio Regulations (IRR) of the International Telecommunications Union (ITU), a specialized agency of the U.N. These allocations could be modified at the 1979 World Administrative Radio Conference (WARC) to include their use for beaming power from space to earth. This modification would require the agreement of a majority of the nations of the world.

The current wording of these allocations is:

The frequency 2450 MHz is designated for industrial, scientific and medical purposes except in Albania, Bulgaria, Hungary, Poland, Roumania, Czechoslovakia and the U.S.S.R., where the frequency 2375 MHz is used. Emissions must be confined within  $\pm 50$  MHz of the frequencies designated. Radiocommunication services operating within these limits must accept any harmful interference that may be experienced from the operation of industrial, scientific and medical equipment.

The frequency 5800 MHz is designated for industrial, scientific and medical purposes. Emissions must be confined within the limits of  $\pm 75$  MHz of that frequency. Radiocommunication services operating within those limits must accept any harmful interference that may be experienced from the operation of industrial, scientific and medical equipment.

The 2 GHz band is shared with fixed and mobile communication systems and with radars.

The 5 GHz band is shared with communication satellite uplinks, radars, and fixed and mobile communication systems.



The Master Frequency List of the ITU contains station registrations by the following countries for communication purposes:

2400 to 2500 MHz - England, West Germany, Holland, France, Belgium, Czechoslovakia\*, Austria, U.S.S.R.\*, Yugoslavia, Sweden, Turkey and Mexico.

5725 to 5875 MHz - West Germany, Poland, U.S.S.R., Sweden, Italy, Czechoslovakia and Yugoslavia.

\*Not an industrial band in these countries.

Some stations registered by England and Holland are troposcatter stations, which have large antennae and are especially sensitive to interference.

The Master Frequency List usually contains only a small percentage of the stations actually operating.

Despite the wording of the current allocations, it is not likely that a service that may potentially illuminate about half the world would be given the same freedom to cause RFI as is given to ground based ISM equipment.

The power spectral flux density (PSFD) limits of the earth's surface that can be expected to cause RFI, and which would probably be imposed as regulatory limits can be implied from parts of the IRR that apply to other space transmitters.

Near 2 GHz an upper limit between -154 and -144 dBW/m<sup>2</sup> in any 4 KHz band is required, depending on angle of arrival at the surface of the earth. Near 5 GHz the limits are -152 and -142 dBW/m<sup>2</sup> in 4 KHz (Ref. A). These limits were established to protect line-of-sight (LOS) microwave relay links (Ref. B).

Near 2 GHz an additional restriction is contained in the IRR to protect troposcatter (TS) links. This limits the interfering signal at the receiver terminals of a troposcatter link to no more than -168 dBW in any 4 KHz band. The limit was established in this manner because of the difficulty in defining a generic antenna size (Ref. C).

The exact protection afforded to Radio Astronomy (RA) is not clear (Ref. D), but in practice the U.S. has tended toward the recommendations of the International Radio Consultative Committee (CCIR) of the ITU for RA antennae at the isotropic level (Ref. E). This is -247 dBW/m<sup>2</sup>·Hz near 2 GHz, and -241 dBW/m<sup>2</sup>·Hz near 5 GHz.

As for RA, no specific protection is afforded to deep space research (DSR) in the IRR. However, the applicable CCIR recommendation is not to exceed  $-220 \text{ dBW/m}^2 \cdot \text{Hz}$  at the ground receiver terminals for more than 5 minutes per day (Ref. F).

The TS and DSR values can be changed to a PSFD by assuming antenna types. The geometric mean of the TS antenna sizes mentioned in Reference C is 10 meters. The largest DSR antennas currently in use are 64 meters in diameter. To protect these systems on the antenna boresight requires PSFD limits of  $-185 \text{ dBW/m}^2$  in 4 KHz and  $-253 \text{ dBW/m}^2 \cdot \text{Hz}$ , respectively. For a DSR antenna at the isotropic gain angle, the required protection would be  $-191 \text{ dBW/m}^2 \cdot \text{Hz}$ .

Figure 1-13 is abstracted from Reference 4 and shows the estimated magnitude of noise power spectral flux density from an SPS equipped with either amplitrons or klystrons, assuming certain noise and filter characteristics (since such high efficiency, high power level devices have yet to be constructed and tested).

The various PSFD limits are shown on the diagram. Note that they are all expressed as  $\text{dBW/m}^2 \cdot \text{Hz}$  and that the TS and DSR limits contain the assumption mentioned. Also, the limit for a 60 dBi RA antenna is shown.

Note that harmonics appear to pose an especially severe problem.

In addition, consideration must be given to the power signal itself. For a transmitted power of 6500 MW (Section 1.4.2) and the antenna pattern of Figure 1-9, the power flux density (PFD) near the edge of the earth seen from the SPS would be about  $-65 \text{ dBW/m}^2$  for a single SPS. The high level of the power beam will tend to saturate and block the front end of many receivers, leading to distortion and in some cases loss of desired signals in the affected receivers. The power signal could probably be filtered, but existing equipment is not so equipped.

As an example: at 2450 MHz, assuming an LOS antenna with RFI entry at the 0 dBi antenna gain angle, the interfering signal would be  $-94 \text{ dBW}$  or  $-64 \text{ dBm}$ . This is sufficient to cause overloading interference effects even when considerably removed from the LOS frequency of operation.

A common technique for reducing PSFD is spectrum spreading. If the SPS power were uniformly spread in frequency it would have to occupy approximately 3200 GHz in order to meet the LOS protection criterion.

I-27

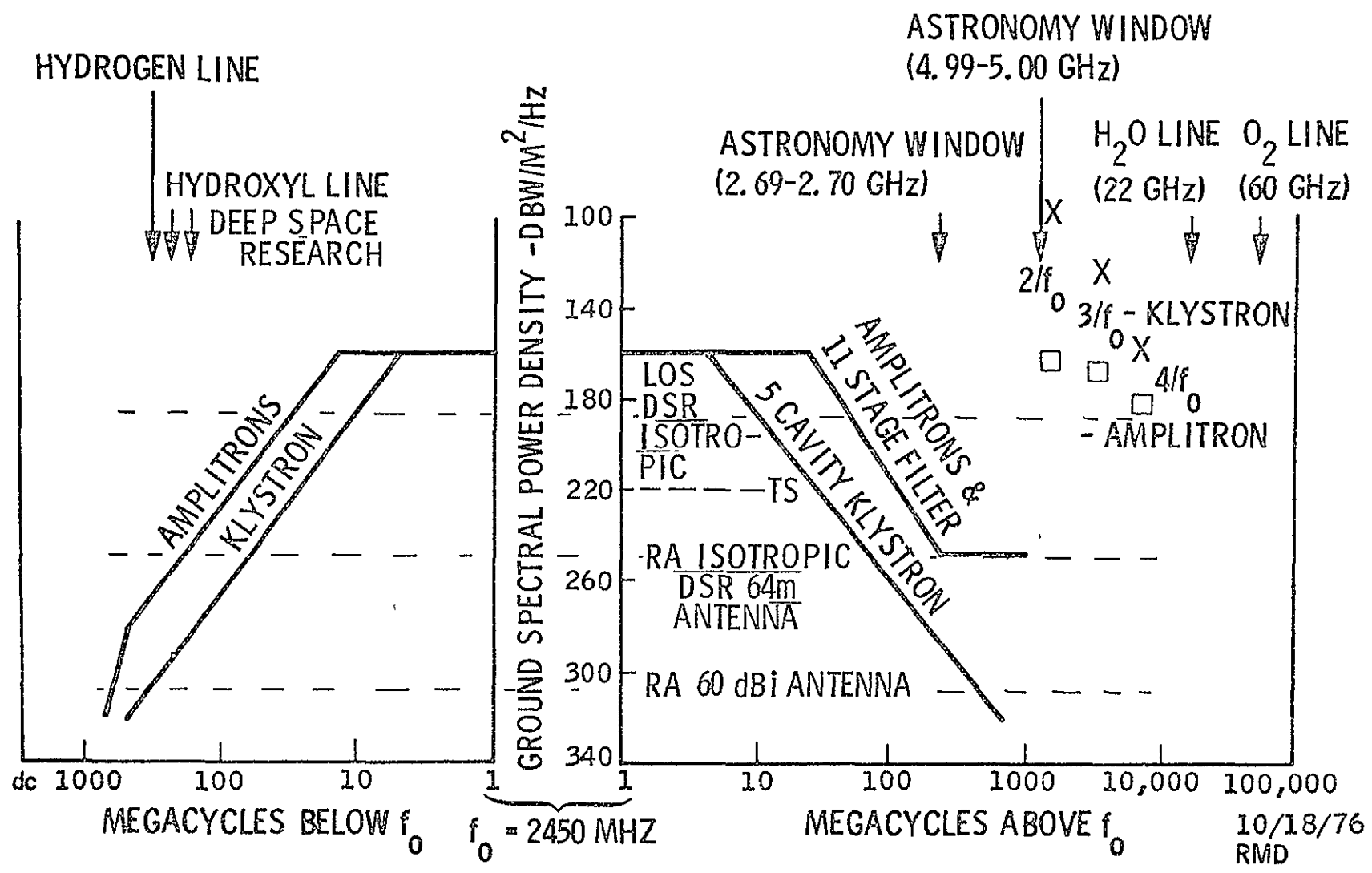

008-006

Fig. 1-13. SPS noise PSFD at the ground. (after Ref. 4.)

The solution to these aspects of the SPS RFI problem can probably be found in the international regulatory arena if international agreement can be reached on the following:

1. A clear-channel or RFI acceptable frequency allocation to an SPS service. No service operating in the SPS allocation could claim protection from RFI. This is like the current ISM allocation.
2. Acceptance of stringent regulation of the out-of-band emissions of the SPS to much lower than those shown in Figure 1-13.
3. Responsibility of ground receivers, operating outside the SPS band, for the rejection of the SPS signal in the SPS band. In other words, the operating organizations would have to fit their receivers with SPS band rejection filters.

#### 1.4.4 Occupational Health Effects

Occupational health hazards of the high-power microwave array include not only the direct microwave beam in front of the array, but also the leakage around the array edges or due to stress cracked waveguides, open joints, missing subarrays or components and RF energy scattered off the spacecraft structure, other spacecraft or objects in the beam. Orthogonally intersecting plane surfaces which can be present in the spacecraft structure and equipment, may produce "effective" corner reflector antennas with resulting microwave flux density concentrations of greater than 10 or 10 dB above the "free space" ambient illumination, due to standing waves. The "hot spots" of microwave radiation present an occupational hazard.

The known thermal effects of high-intensity microwaves (greater than 10 mW/cm<sup>2</sup>) include heating and cataracts, "steam" explosions in trapped liquid situations, combustion in oxygenated environments and other carbonizations. The effects attributed to low level microwave radiation are controversial (Ref 8).

In addition to the microwave radiation, the power transmitting array must also radiate approximately 1 GW of thermal, waste heat. Depending upon the dc to RF converter type, the structure may be at temperatures upwards of 200° C. The klystron collectors may run white hot, whereas the amplitron radiators

are planned not to exceed  $300^{\circ}\text{C}$ . Such hot objects represent a danger to personnel and equipment. Conversely, when the spacecraft is well into the longest eclipse period (about 72 minutes), the structure may chill down to minus  $250^{\circ}\text{C}$ . Rapid heat loss may be experienced unless proper precautions are taken before personnel contact exposed structure.

Depending upon the converters and their operating voltages, there may be X-rays emitted from the decelerating electrons striking the collectors. Also, the high voltages, conducting plasmas, and differential spacecraft charging represent hazards due to potentially lethal currents or distracting arcing and RFI in communications channels.

The rotating interface between the antenna which must face the earth, and the spacecraft solar collectors which must face the sun provides a bodily hazard mechanically as well as a distracting, moving artificial horizon, which may promote disorientation. Mechanically actuated "leveling" jacks on the subarrays will also have exposed moving parts.

The antenna structure will block line-of-sight and hence communications and surveillance. Alternate relay techniques will be necessary to monitor or stay in touch with personnel and equipment. The RFI of the beam power and its harmonics will not simplify this problem.

The effects of sudden turn-on or turn-off of subarrays due to normal eclipse or failure modes, may lead to localized sudden mechanical-thermal stresses in members, with subsequent deflections not ordinarily encountered. Similarly, local unbalances in the magnetic fields surrounding heavy current conductors may give rise to sudden unbalancing torques.

The eclipsing of portions of the array may lead to hazardous lighting conditions for work crews.

In summary, the major occupational health effects attributed to the microwave antenna are microwave radiation, thermal or infrared radiation and high voltages.

#### 1.4.5. Construction

Impacts and benefits to society during the construction phase of the transmitting array are probably small, particularly if the antenna is not

checked-out during LEO. The array will be made from materials delivered to the orbital construction site. The various communications required for use during construction in order to control teleoperators, other data links, video, audio and the laser links employed for alignment, all will have potential for creating RFI and EMI on the earth and with other spacecraft.

#### 1.4.6. Security

Terrorist acts or sabotage directed at the transmitting array will more than likely arrive via the coded command and pilot signal receivers, thus security measures must be applied to these channels. The concentrated power transfer interface at the rotating joint between the array and the spacecraft solar collectors probably also represents a vulnerable spot that is worthy of security in some form. Obviously, the power beam off control must be held inviolate in order to assure that the ultimate beam safety condition can be achieved.

#### 1.4.7. Conclusions

First and foremost, in the near field of the antenna the microwave beam is a lethal hazard because of the high flux density. Unprotected personnel and equipment must be prevented from entering the beam near the array even when it is unfocused. Absolute safety can only be assured by being considerably in the far, far field of the beam or else having the converters turned off.

Extreme care must be exercised in testing the antenna and in approaching and moving about the antenna during operations and maintenance. Also, security and safety in the beam control subsystems must be fail-safe.

Second, meeting the required design sidelobe and grating lobe levels and maintaining them for 30 years lifetime will be quite difficult. (However, not to do so would be to violate a safety requirement or to exacerbate an RFI condition.) The lobe levels are determined by the array output power level, amplitude taper, and the aperture phase and amplitude errors. Table 1. lists the phase and amplitude error contributors for the proposed pilot beam steered, retrodirective phased array mechanization.

Table 1-1. Aperture Error Sources  
Pilot beam steered, retrodirective, power transmitting phased array

I. PHASE

- 1. Pilot Beam Signal-to-Noise Ratio
  - A. Pilot Carrier Level
    - a. Pilot transmitter output
    - b. Ionosphere multipath fading
    - c. Ionosphere storm de-polarization
    - d. Excessive subarray tilt
    - e. Pilot modulation - coding level
    - f. Spacecraft polarization attitude control
    - g. Am to pm conversion
  - B. Noise in Pilot Receiver Bandwidth
    - a. Excessive converter noise
    - b. Waveguide arcs
    - c. Intermodulation products from other communications channels
- 2. Converter Phase Control Feedback Loop Stability
  - A. Converter Output Stability and Noise
  - B. Reference Input Stability and Noise
  - C. Temperature
  - D. Phase Shifter and Phase Detector Stability
- 3. Phase Reference Distribution
  - A. Noise Added at Branches and Modes, Line Amplifiers
  - B. Aging Dispersion in Pilot and Conjugated Signal Paths

- 4. Initial Phase Trim Resolution and Stability
  - A. Instrumentation Resolution
  - B. Phase Shifter Setability
  - C. Thermal and Aging Stability
- 5. Propagation Path Stability
  - A. Ionosphere Disturbances
  - B. Spacecraft Structure Differential Doppler

II. AMPLITUDE

- 1. Taper Quantization
- 2. Converter Failures
- 3. Excessive Subarray Tilt
- 4. Waveguide Arcs
- 5. Converter Output Degradation
  - A. Poor Power Supply Regulation
  - B. Low Cathode Emission
  - C. Low RF Drive Level

I-31

900-800

Third, the impacts and benefits of the microwave power transmitting array are potentially very serious as regards interference with existing radio communications systems because of the combined satellite visibility from the earth and the tremendous power level. A detailed assessment of the various radiation levels, frequencies, polarizations and spatial distributions must be made in order to then determine the population of existing radio spectrum and other spectrum users who will be affected.

#### 1.4.8. Recommendations

Beam safety control schemes need to be investigated and developed so as to demonstrate that positive control can be exercised. Provisions for alternate power levels for use in testing need to be investigated.

In view of the many phase error contributors and the desire for long term-low level phase errors, analysis and simulation of the phase control system approaches needs to be undertaken to prove the feasibility of such goals as 10 deg. rms phase error for 30 years.

The safety aspects of operations and maintenance of the array should be detailed.

Other uses of the SPS power beam should be looked into with the view of adapting properties of the beam to perhaps supplant or provide superior or more economical performance for some of the navigation functions it may interfere with.



## SECTION II

## MICROWAVE BEAM PROPAGATION

## SUMMARY

PRECEDING PAGE BLANK NOT FOLLOWS

The impacts and benefits of the propagating microwave beam of the SPS are presented and discussed. For the proposed S-band operating frequency of 2.45 GHz, the major impacts occur in the earth's ionosphere. Nevertheless, the microwave beam existing between the spacecraft transmitting antenna and the ground rectenna must pass through various regions of the earth's biosphere. The resulting energy deposits, conversions, re-directions, etc. are of concern as they can potentially impact radiation shielding, other RF communication signal propagation linearity and security, generation of intermodulation signals and harmonics, chemical processes, material transport, heat balance, and other emissions. In the extreme, the energy deposit via beamed energy transport can sufficiently impact the ionosphere to cause self impact on the energy transfer process, such as pilot beam interference.

Objects in the propagating media can lead to impacts via absorption or scattering as from meteors, meteorological elements such as hail, rain or lightning, birds, insects and aircraft. The beam energy distribution affects the rectenna size and personnel exclusionary zone boundary as well as impacting existing communications systems directly via saturating receivers, or indirectly via intermodulation product generation or mixing harmonics.

## 2.1 INTRODUCTION

The purposes of this study are (1) to evaluate existing analyses of the ionospheric interaction with the Microwave Power Transmission Subsystem (MPTS) beam and (2) to identify any additional impact areas which should be studied. This report briefly describes the ionosphere in its natural and modified states, describes the potential interactions of the ionosphere with the MPTS power beam, and estimates the magnitude of the potential impacts. These include environmental and ionospheric "user" impacts.

The major analytical effort has been done by Raytheon (Ref. 9-10) and is based on their participation in the ionospheric heating experiments at Platteville, Colorado (Ref. 11-12). Since no direct measurements have been made at the proposed power beam frequency (2.45 GHz), it is assumed that the known heating effects at HF can be scaled to the power beam frequency (Ref. 13). The four major impact areas are (1) the power beam effects on the ionosphere, (2) the ionospheric effects on the power beam, (3) the ionospheric effects on the pilot beam, and (4) the effects of the perturbed ionosphere on ionospheric "users".

## 2.2 THE IONOSPHERE

The Raytheon analysis assumes that the ionospheric absorption causes the power beam to be attenuated slightly. "Although only a small fraction of the power beam is absorbed, it is still significant compared to the natural thermal input into the ionosphere" (Ref. 9). The power beam increases the electron temperature, called "ohmic heating," which in turn causes changes in electron density and increases the potential for thermal and plasma instabilities. Since the impacts are different in the D-region (50-90 km) than in the F-region (>150 km) of the ionosphere, the two regions are discussed separately.

In the F-region, the increase in electron temperature depends on frequency, time, and ground site latitude. In the F-region, the most important cooling mechanism is thermal conduction by the electrons along the (Earth's) magnetic field. Although some heat is transferred to ions and neutral particles at all altitudes, the amount of heat deposited near the peak of the F-region

by the power beam is so large that most of it must be conducted down to lower altitudes near 200 km where collisions with neutral particles are frequent enough to cool the electrons" (Ref. 10). The high temperature electrons also move up the field lines many hundreds of kilometers above the beam because the collision frequency ( $\nu$ ) decreases with altitude. Figure 2-1 shows the nighttime region of increased electron temperature. Although the daytime electron temperatures are higher than during the night, a larger percentage increase in temperature results at night "because there are fewer electrons (decreased density) to transport heat away from the dissipation region" (Ref. 10) (see Figure 2-2).

The effects are site dependent because of the relationship of electron temperature, the beam elevation angle, and the Earth's magnetic field (Figures 2-3 and 2-4). Electron temperature increases are larger when the beam and the magnetic field are more closely aligned, so the impacts are larger at lower latitudes (the "Southwest site"). Thus, the large electron temperature increase in the presence of the power beam can produce large changes in electron density and provides a great deal of potential energy to drive thermal and plasma instabilities

The amount and rate of change of the electron density are primary parameters of interest in the analysis. In the F-region, the presence of the power beam results in a decrease in the electron density because of the thermal expansion of the "electronic fluid." If there were no relative motion of the ionosphere with respect to the beam, the electron density would decrease up to 40% in a few thousand seconds (Figure 2-5). The largest changes occur at night (lower cooling rate) and at lower latitudes (larger electron temperature changes). However, the F-region ionosphere will move through the beam as a result of the electrodynamic drift. The drift velocity can vary from 10 to 200m/sec with an average velocity of about 50 m/sec. A given volume of ionosphere will move through the beam in ~200 seconds, with the beam-induced heating causing a decrease in density. Once outside the beam, this volume will increase in density back to its natural level in about the same amount of time. Thus, there will be a downwind "wake" from the beam approximately doubling the region of beam influence, but the average electron density reduction caused by

MP

2-4

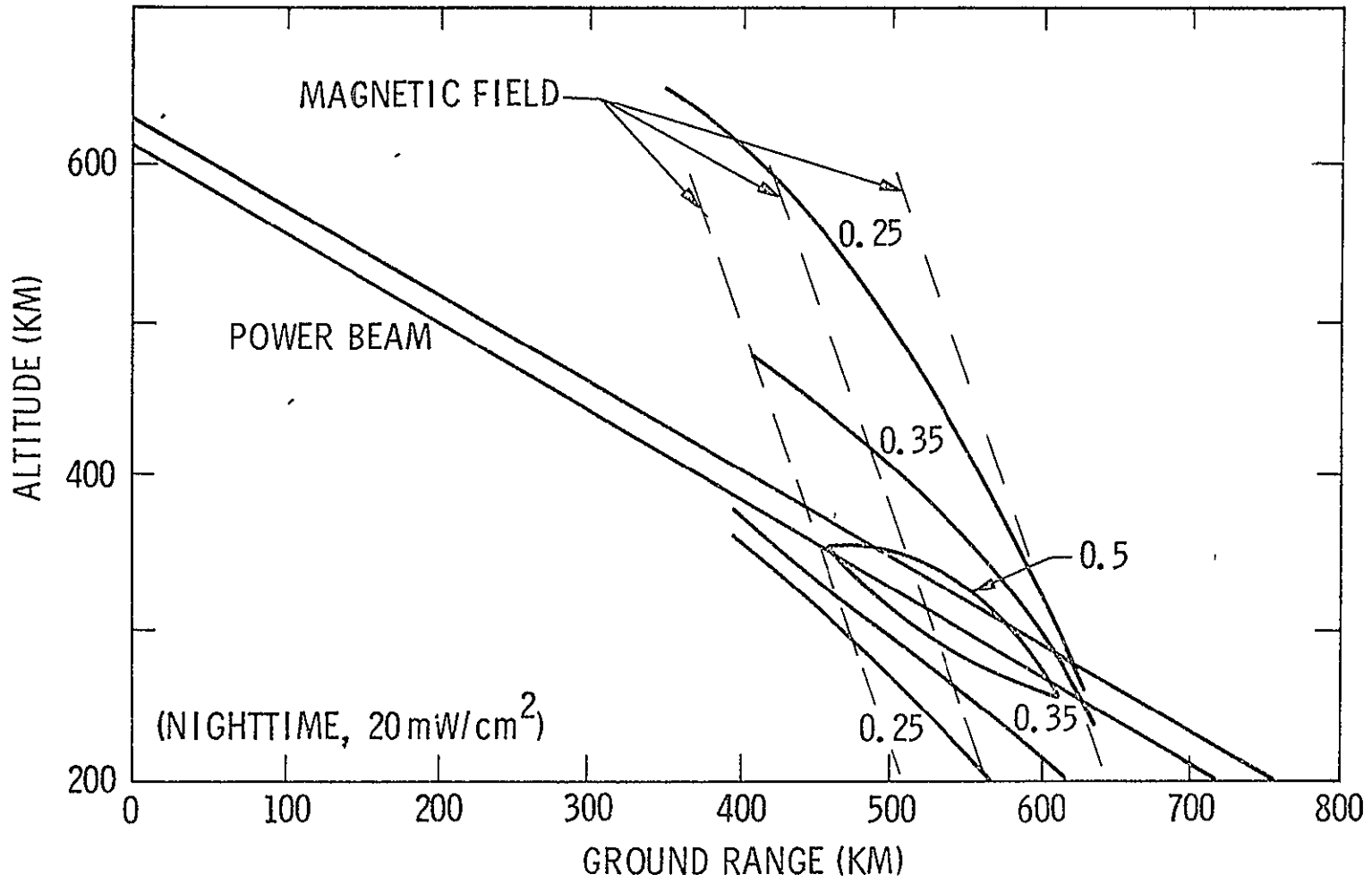

900-800

Fig. 2-1. Contours showing the fractional increase in temperature of the electrons in the meridian plane through the axis of the beam, for a nighttime profile at the Northeast site (from Ref. 10)

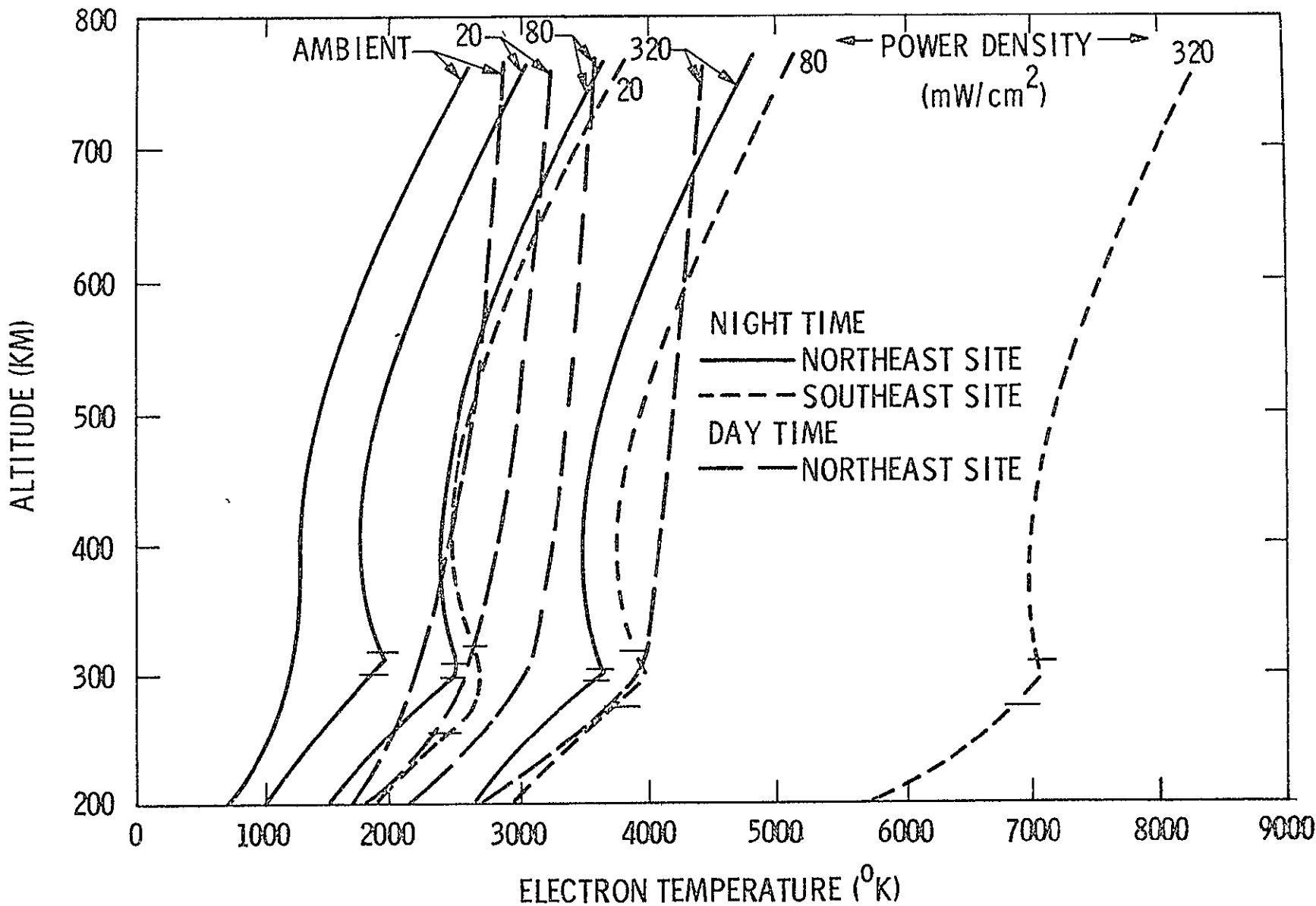

Fig. 2-2. Steady-state temperature of the nighttime ionosphere as a function of altitude for the power levels and locations specified. The slash marks on each curve specify limits for the altitude range, centered near 300 km, over which the flux line was heated (from Ref. 10)

2-5

900-800

9/16

# NORTHEAST SITE

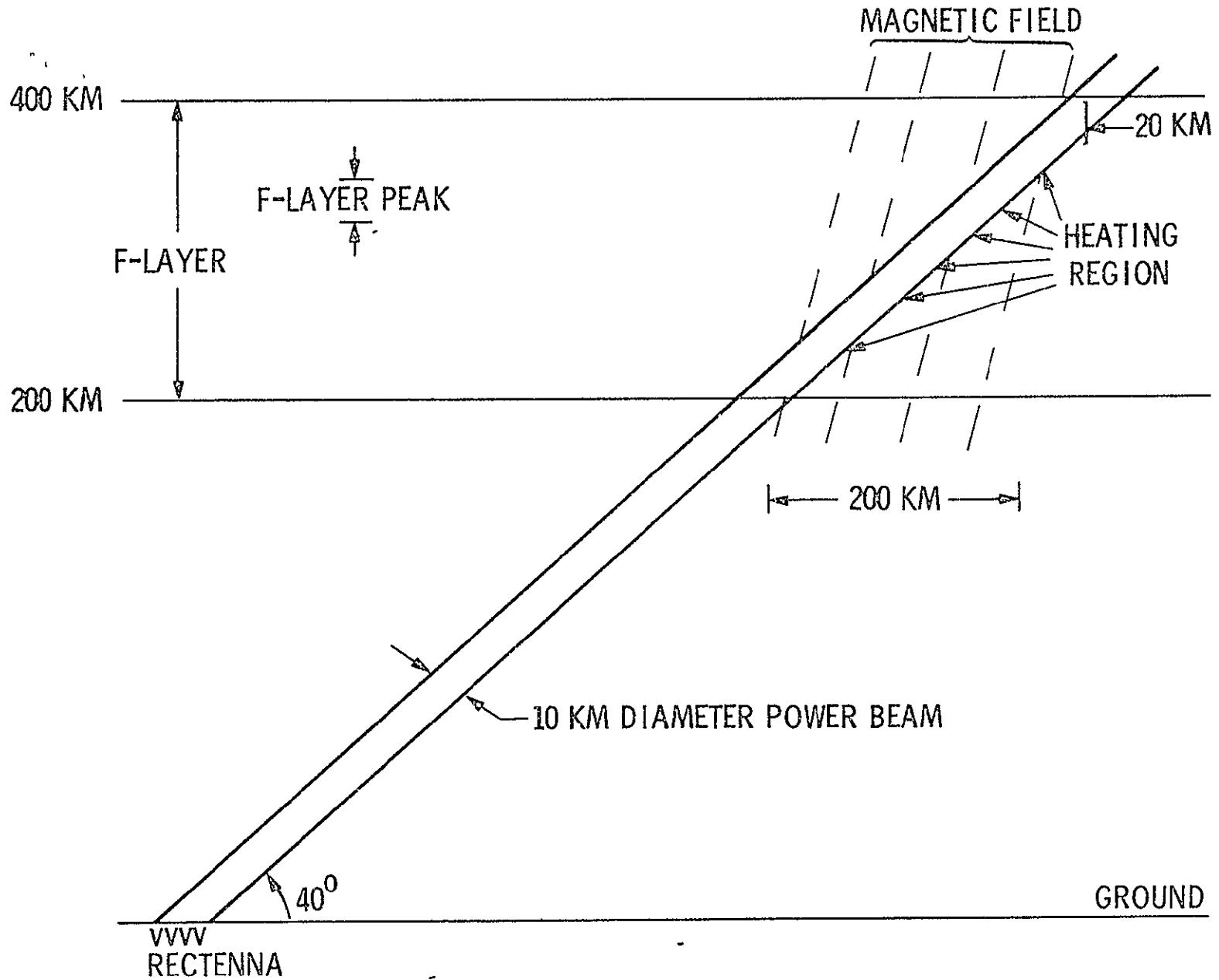

2-6

900-800

Fig. 2-3. Relationship of the Earth's Magnetic Field and the Power Beam at a Northeast Site Near Bedford, Massachusetts (from Ref. 10)

17

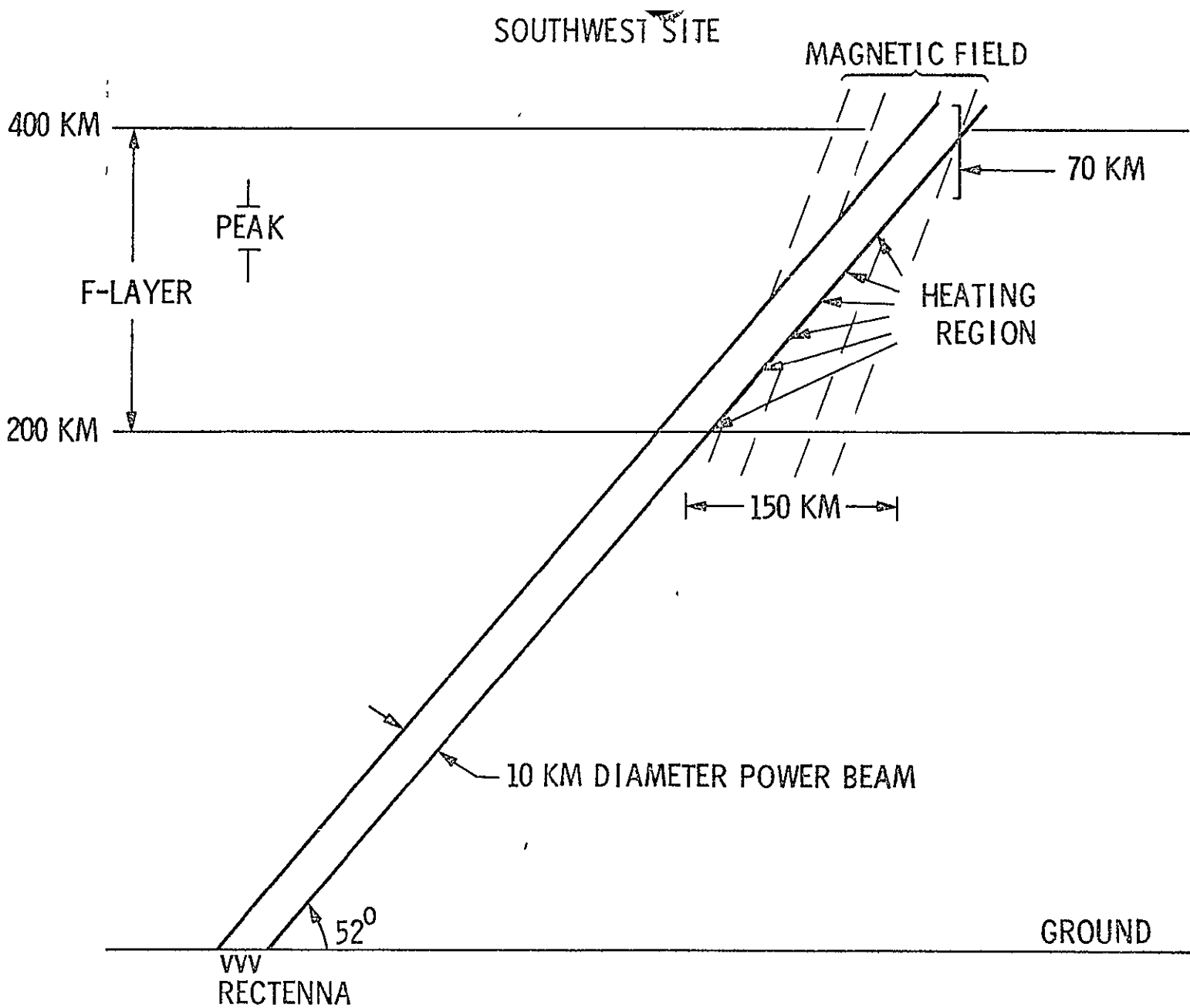

2-7

900-800

Fig. 2-4. A Near-grazing angle between the power beam and the geomagnetic field at a southeast site, near White Sands, New Mexico (from Ref. 10)

2-8

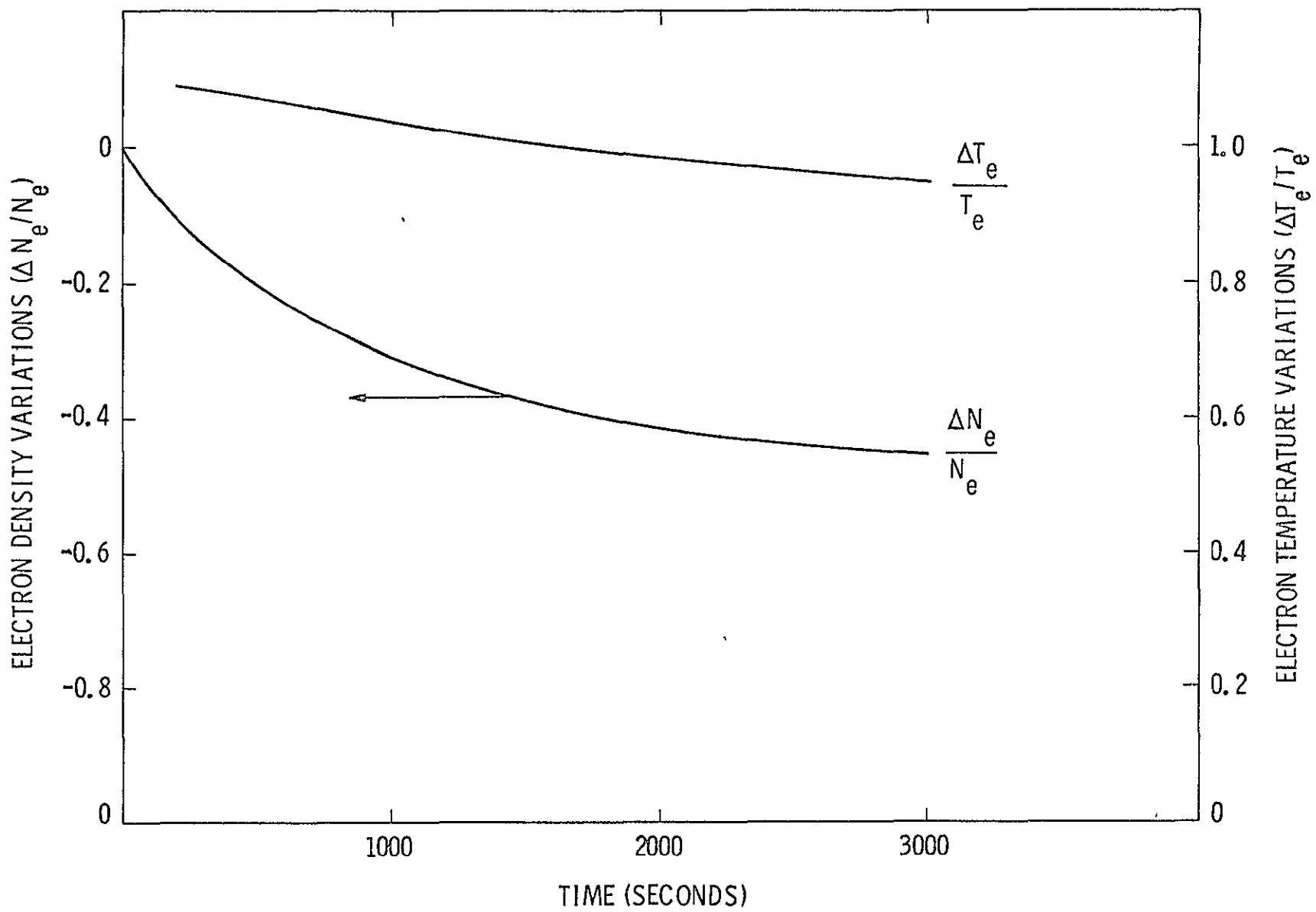

900-800

Fig. 2-5. Fractional change in nighttime temperature and electron density over White Sands when 20 m W/cm<sup>2</sup> is applied to a line of force over a long period of time and over a height range from 260 to 325 km (from Ref. 10)



the beam can be much less than the maximum value (see Figure 2-6) and will only reach its maximum value when the drift velocity is near zero. The effect of ionospheric drift on the electron temperature will be small because of the short time constant (~10-30 sec) of electron temperature changes.

A major impact in the F-region is the potential for increasing irregularities in the electron density of the region. The natural ionosphere contains many irregularities which cause scintillations in satellite-Earth links (Ref. 13) and result in disrupted ionospheric propagation. The MPTS will have a large impact on scintillations because their natural levels are low at midlatitudes where most of the ground sites will be located.

In the D-region of the ionosphere, the power beam increases the electron temperature many thousands of degrees (see Figure 2-7). The electron temperature increase occurs very quickly after the power beam is turned on. The neutral gas density is much higher here than in the F-region, so "collisions are so frequent that thermal conductivity can be completely neglected (i.e., the heated electrons do not move out of the heating region); therefore, the energy imparted to the electrons from the power beam is transferred to the neutral gas at the same point in space at which it is absorbed (Ref. 10).

The result is that the electron density within the beam increases significantly because first order density changes are proportional to electron temperature. As the density increases, absorption also increases and the temperature will in turn increase. However, the process is stabilized by the various energy loss processes. The time dependence of the electron temperature can be written as

$$\frac{\partial T_e}{\partial t} = k_1 \cdot \text{POWER DENSITY} - k_2 \cdot \Sigma \text{LOSSES}$$

where the major losses are due to:

- (1) electron rotational excitation,
- (2) oxygen fine structure transitions,
- (3) vibrational loss due to  $N_2$ , and
- (4) elastic energy loss.

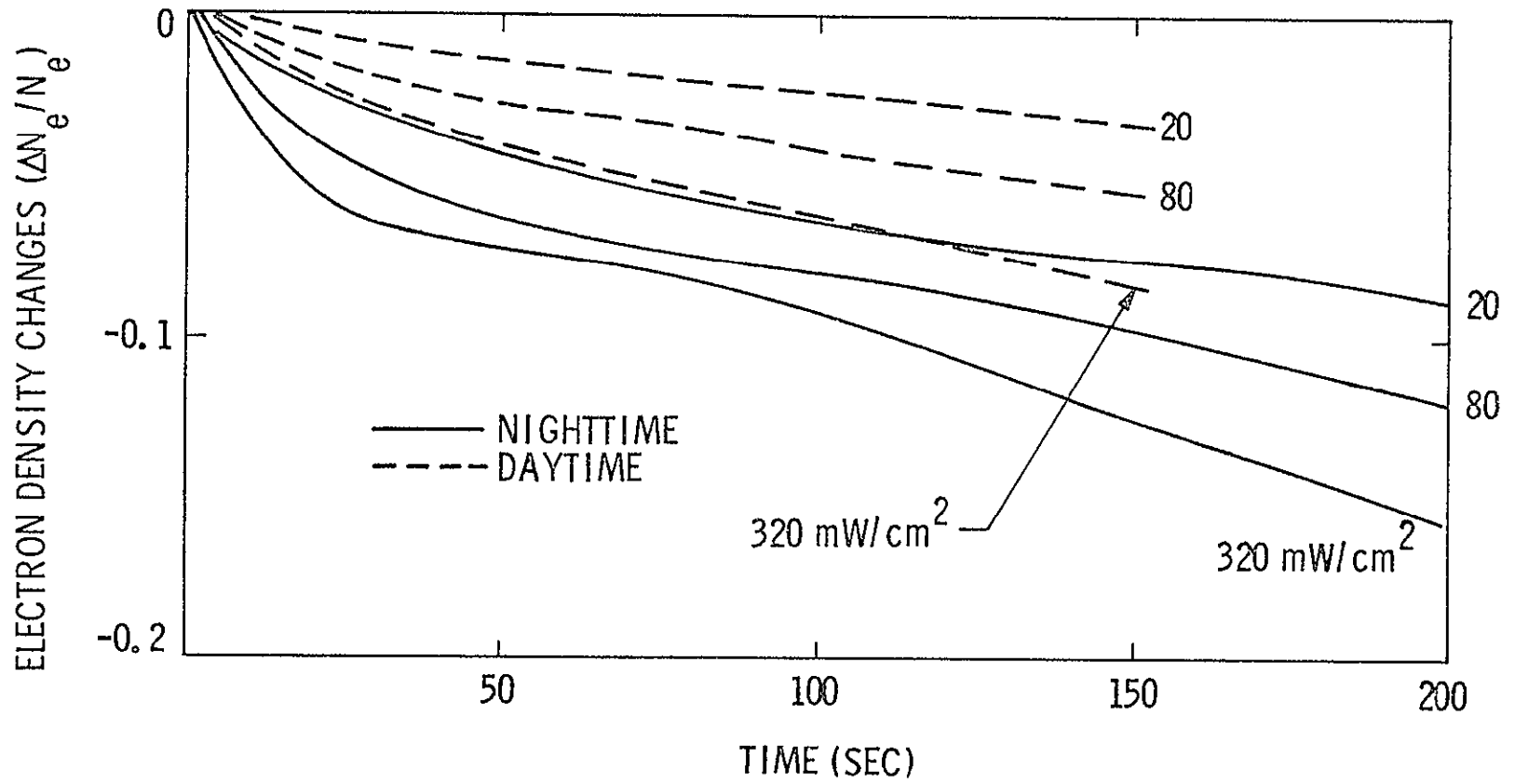
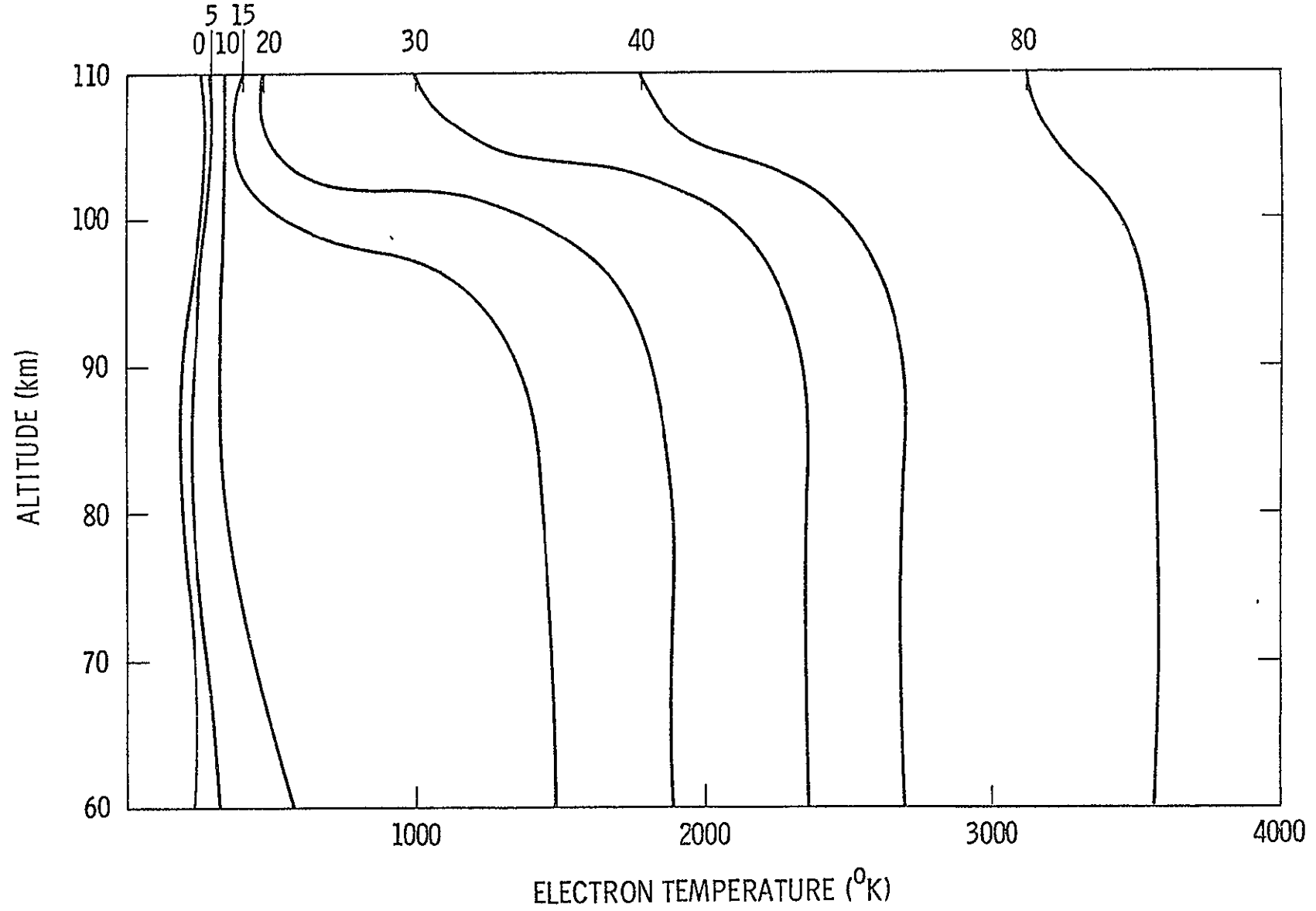

Fig. 2-6. Decrease in electron density at the Northeast site for both daytime and nighttime ionospheres, calculated for 3 different Poynting fluxes (from Ref. 10)

2-11



900-800

Fig. 2-7. Electron temperature as a function of altitude for power fluxes from 0 to 80 mW/cm<sup>2</sup>. Intermediate fluxes like 20 mW/cm<sup>2</sup>, may exceed the critical flux at lower altitudes but be below the critical flux at 110 km, since the critical flux increases as the relative concentration of atomic oxygen becomes larger (from Ref. 10)

The critical power density has been defined (Ref. 14) as the "power level above which the losses due to (1) and (2), by themselves, are not sufficient to keep the temperature stable, without including the losses due to (3) and (4)" (Ref. 10). The critical power density is a function of altitude and has a minimum value of about  $15 \text{ mW/cm}^2$  at 60 km. Since the threshold is analytical rather than physical, there appears to be some flexibility of the specification of maximum power density.

In the D-region, the power beam effects are not confined to the beam cylinder because atmospheric winds cause drifts on the order of 50 m/sec. The winds will provide an additional "loss mechanism" to reduce the heating within the beam, and they will cause a downwind wake similar to that in the F-region. Because the response time of the D-region density is relatively short, the wake will probably not extend more than 10-20 km from the beam. Temperature changes in the D-region will be confined mostly to the beam region.

There is a very complicated interaction between the lower D-region and the mesosphere. This interaction involves the ionization of many molecules as well as vertical and horizontal circulation patterns which continually mix the ionosphere and the upper atmosphere. Since the mixing can cover large areas, modifications of the lower D-region can affect lower altitude chemistry, and have impacts on the ozonosphere, for example. In the upper mesosphere, the concentration of ionic and polar molecules may be increased substantially. This increase in turn can produce Raman scattering, i.e., radiation not at 2.45 GHz. This radiation could prove to be a substantial RFI source, and calculations are necessary to evaluate this effect (Ref. 15).

A major area of concern for both D- and F-region interactions is the possibility of plasma instabilities. There are many types of instabilities which could be produced in the modified regions, especially since these regions are so large (10 km diameter). Raytheon (Ref. 9) has evaluated the self-focusing instability, and Perkins and Robles plan to reassess this general class of instabilities (Ref. 15). However, there are many other types of

instabilities which could be produced, and a complete systematic evaluation of the potential for all instabilities should be made.

### 2.3 EFFECTS ON IONOSPHERIC USERS AND OTHERS

The effects of the perturbed ionosphere include reduced performance of systems which use the ionosphere for propagation. These systems have been identified, and the effects have been investigated (Ref 10) to obtain a qualitative level of the impact on three classes of systems: navigation, communication, and DOD radars. Tables 2-1 to 2-3 summarize the results of typical cases. These systems use the ionosphere as a reflector to propagate over very long distances - thousands of kilometers in some cases. Therefore, an ionospheric disturbance far removed from the user can cause degradations in system performance "For example, a user located in the middle of the U.S. would be affected by every power beam that is contained in the U.S." (Ref. 10). The prospect of 100-200 power beams makes the probability of interference relatively large.

Another class of communications systems can be affected by the disturbed ionosphere. All communications links which pass through the ionosphere can potentially be degraded by ionospheric irregularities, i.e., scintillations. Earth-satellite links of spacecraft in low-Earth-orbits or geosynchronous orbits and beyond can experience fading and reduced telemetry and tracking performance in the UHF range. Even at higher frequencies, the scintillations can cause errors in satellite range and position measurements, especially if the concept of "power parks" is implemented, where the rectenna arrays are grouped in remote areas. Tracking stations for deep space probes usually are located in these remote locations, also. However, the measurement errors introduced will probably be small, but may be significant in some cases.

The potential for cross-modulation (or an effect like cross-modulation) exists since the power beam is so intense. As strictly defined, cross-modulation is the imposition of the disturbing signal's amplitude modulation onto a desired signal passing through the same region. This interaction results from ionospheric perturbations of collision frequency, ion chemistry and electron density induced by the disturbing wave. Strictly speaking, a truly CW power beam should produce no cross-modulation of AM signals passing

57

TABLE 2-1. IMPACTS ON IONOSPHERIC USERS: NAVIGATION SYSTEMS (FROM REF. 10)

SYSTEM	SYSTEM CHARACTERISTICS	POWER BEAM EFFECTS	RECOMMENDATIONS
OMEGA	<ul style="list-style-type: none"> <li>◦ 10.2 KHZ, CW</li> <li>◦ 8 STATIONS, TDMA</li> <li>◦ SINGLE FREQUENCY HYPERBOLIC SYSTEM (PHASE COMPARISONS)</li> </ul>	<ul style="list-style-type: none"> <li>◦ IONOSPHERIC EFFECT COULD CAUSE SUDDEN PHASE ANOMALIC</li> <li>◦ PHASE ANOMALIES COULD INCREASE LOCATION ERROR BY A FACTOR OF 5 (1 TO 5 MILES).</li> </ul>	<ul style="list-style-type: none"> <li>◦ THEORETICAL CALCULATIONS OF POWER BEAM EFFECTS AND COMPARE WITH OBSERVED SPAs.</li> <li>◦ ESTABLISH SEVERAL OMEGA LINKS WHICH PASS THROUGH HEATED VOLUME.</li> </ul>
LORAN C	<ul style="list-style-type: none"> <li>◦ 100 KHZ, PULSE</li> <li>◦ GROUND WAVE (2000 KM) AND SKY WAVE (8000 KM)</li> <li>◦ HYPERBOLIC SYSTEM</li> </ul>	<ul style="list-style-type: none"> <li>◦ NONE ON GROUND WAVE</li> <li>◦ FOR SKY WAVE USERS POWER BEAM COULD DEGRADE PERFORMANCE ALTHOUGH SKY WAVE USERS FAR REMOVED FROM DISTURBED REGIONS.</li> </ul>	<ul style="list-style-type: none"> <li>◦ LIKELY NOT TO BE SIGNIFICANTLY EFFECTED.</li> <li>◦ SINCE LORAN C EQUIPMENT READILY AVAILABLE, PARALLEL EXPERIMENTS WITH OMEGA SHOULD BE CONSIDERED.</li> </ul>
NAVSTAR GPS (GLOBAL POSITIONING SATELLITE)  1st SATELLITE IN MAY 1977	<ul style="list-style-type: none"> <li>◦ THREE-D LOCATION USING 4 SATELLITES</li> <li>◦ 1200 AND 1600 MHZ (TWO FREQUENCIES ELIMINATE RANGE ERROR OF IONOSPHERE)</li> <li>◦ USE OF IONOSPHERIC MODEL FOR SINGLE FREQUENCY USER</li> <li>◦ DESIGNED FOR LOW GAIN OMNI-RECEIVE ANTENNA</li> </ul>	<ul style="list-style-type: none"> <li>◦ ELECTRON DENSITY CHANGES WILL NOT AFFECT TWO-FREQUENCY USERS.</li> <li>◦ ELECTRON DENSITY CHANGES INCREASE ERROR BUDGET FOR SINGLE-FREQUENCY USERS.</li> <li>◦ IRREGULARITIES COULD CAUSE SCINTILLATIONS WHICH COULD PREVENT SYNC ACQ BY UNSOPHISTICATED USER.</li> </ul>	<ul style="list-style-type: none"> <li>◦ POSITIONING SYSTEM OF THE 1980s AND ITS IMPORTANCE MAKES IT MANDATORY TO EXPERIMENTALLY DETERMINE EFFECTS OF HEATING</li> <li>◦ MONITOR PERFORMANCE OF GPS, PARTICULARLY OVER EQUATORIAL REGION</li> </ul>

2-14

900-800

TABLE 2-2. IMPACTS ON IONOSPHERIC USERS: COMMUNICATION SYSTEMS (FROM REF. 10)

SYSTEM	SYSTEM CHARACTERISTICS	POWER BEAR EFFECTS	RECOMMENDATIONS
HF	<ul style="list-style-type: none"> <li>• 3-30 MHZ</li> <li>• USES IONOSPHERE AS REFLECTOR TO PROPAGATE AT RANGES FROM 400-800 KM</li> </ul>	<ul style="list-style-type: none"> <li>• PROPAGATION OUTAGES</li> <li>• LOSS OF COMM LINKS</li> <li>• MANY USERS AFFECTED                             <ul style="list-style-type: none"> <li>- HAM</li> <li>- MILITARY</li> <li>- CIVILIAN</li> </ul> </li> </ul>	<ul style="list-style-type: none"> <li>• ESTABLISH SEVERAL HF LINKS WHICH PASS THROUGH AND NEAR HEATING REGIONS DURING EXPERIMENT.</li> </ul>
AFSATCOM	<ul style="list-style-type: none"> <li>• ~ 260 MHZ</li> <li>• ~ 340 MHZ</li> <li>• SATELLITE-TO-AIRCRAFT COMMUNICATION SYSTEM</li> </ul>	<ul style="list-style-type: none"> <li>• FADING DUE TO SCINTILLATIONS</li> <li>• ASPECT SCATTER COULD CAUSE MULTI-PATH DEGRADATION</li> </ul>	<ul style="list-style-type: none"> <li>• SIMULATE WITH GROUND-BASED COMMUNICATION SYSTEMS.</li> <li>• FLY AIRCRAFT WITH COMM. SYSTEMS NEAR HEATING REGION.</li> <li>• MEASURE SCINTILLATIONS AT 400 MHZ CAUSED BY HEATING.</li> </ul>
INTELSAT/ MARISAT	<p>1200 MHZ 1600 MHZ 6000 MHZ      MARISAT 4000 MHZ</p>	<ul style="list-style-type: none"> <li>• FADING, IF SEVERE COULD BE SIGNIFICANT</li> </ul>	<ul style="list-style-type: none"> <li>• MEASURE SCINTILLATION DURING HEATING EXPERIMENT.</li> </ul>

2-15

900-800





through the perturbed region. However, amplitude variations of the power beam are inherently present, due both to power source variations and to amplitude scintillations either natural or induced by the power beam. Since the induced cross modulation is proportional to the power in the disturbing wave (Ref 16), even minor variations in the power beam amplitude may produce large amounts of cross-modulation. The actual levels and specific conditions under which this effect occurs should be studied in more detail.

There is a possibility that some of the power beam energy will be reflected by the ionosphere. Even though the reflection coefficient may be very small, a significant amount of power could be reflected. The geometry dictates that this energy would be reflected toward the polar regions, so the only interference would be with satellites in highly-inclined orbits. Scattering by the ionospheric irregularities could also produce interference outside the beam.

Another impact on communications is the effect of the disturbed ionosphere on Space Shuttle-type communication links. In the MPTS era, many missions are projected to be using the 200-400 km orbital region for construction of large space facilities, like the MPTS. Thus, the Earth-space communication links for these missions will potentially be degraded if the link frequency is below 1 GHz. Another related problem is that the disturbed ionosphere will also distort space-based RF measurements of the Earth's surface. Possible measurements include RFI monitoring systems and radiometry to determine atmospheric states. These measurements would be reduced in accuracy by the ionospheric disturbances induced by the power beam.

#### 2.4 POWER BEAM EFFECTS

The effects of the ionosphere on the power beam have been estimated to be minimal (Ref. 9). The effects include power absorption, beam displacement, Faraday rotation, dispersion and beam defocusing. Since the ionosphere contains mobile electrons, it acts as a conductor with a finite amount of attenuation (absorption). The maximum absorption will occur at about 70 km during the daytime. On the average, the signal attenuation will be about  $10^{-3}$  dB, with peak attenuations of  $10^{-2}$  dB occurring for an hour or less a few times each year.

This loss is relatively insignificant. Beam displacement is the result of refraction through electron density gradients at the various ionospheric levels. The average displacement will probably be less than 40 meters, with peak values reaching 100 meters during severe ionospheric storms. These values are so small compared with the beam diameter that the displacement will have no effect on system performance.

Faraday rotation is the change in the beam polarization direction. The rotation occurs when waves propagate through a plasma in the presence of a magnetic field. The amount of rotation depends on the total electron content in the path length and on the orientation of the Earth's magnetic field with the beam direction. The rotation will vary with time of day, season, and solar activity because of the varying electron densities. The average rotation at higher latitudes will be from  $0^\circ$  to  $6^\circ$ , with a  $10^\circ$ - $12^\circ$  peak rotation occurring for short periods a few times a year. With linearly polarized antennas (assumed for the MPTS), Faraday rotation produces a direct polarization loss. This loss can be as much as -0.15 dB for  $10^\circ$ - $12^\circ$  rotations, but the loss would be greatly reduced if the MPTS antenna could be rotated to compensate for slow variations (e.g. diurnal) in the rotation angle. Even during strong magnetic substorms when peak rotations occur, the loss could be minimized if the rotation is sensed at the rectenna site and then compensated at MPTS antenna. Thus, Faraday rotation is not significant if it is considered during the system design.

Dispersion is the change in the frequency spectrum of the signal as it passes through the ionosphere. Since the power beam is essentially a CW signal, there is no dispersion in this narrowband signal. The power beam is slightly defocused as it passes through ionospheric irregularities. This results in beam spreading which will place slightly more power at the edge of the rectenna array and cause slightly more loss than if no irregularities were present. The major problem in this case is that the power beam induces the offending irregularities, so the effects are not easily estimated because the irregularity mechanisms are not fully known as yet. However, a power loss of less than 1% is expected due to beam spread spillover at the edge of the receiving array.

## 2.5 PILOT BEAM EFFECTS

The ionospheric effects on the pilot beam will be nearly the same as for the power beam. Absorption, displacement, Faraday rotation, and dispersion will have negligible impact on the pilot beam performance. The only potential problem could be produced by ionospheric irregularities, which can cause variations in the pilot signal when it reaches the power array. The Raytheon analysis (Ref 9) indicates that only small scale (~50 meters) irregularities can cause "phase noise" across the array, and the small scale irregularities are expected to be weak. The phase noise will cause variations in the received pilot beam signal at each subarray, and these variations will in turn degrade the coherence of the power beam. Small-scale irregularities in the natural state may be weak, but it also has not been established that these irregularities will remain weak in the presence of the power beam. The frequency of the scintillations is important because the adaptive phase control system reacts immediately to changes in received signal phase. If ionospheric changes occur between the time the pilot beam passes through the ionosphere and the time the power beam returns (~1/4 sec), the phase control system cannot compensate for the resulting phase errors. The levels of degradation due to induced scintillations have not been estimated, so some analytical work is necessary in this area.

Another potential problem area associated with the phase control system involves pilot beam amplitude variations across the array. Small-scale irregularities in the ionosphere induce amplitude variations across the pilot beam wavefront. These amplitude variations can cause phase errors in the phase control system. The "AM-to-PM" conversion problem is presently being investigated, and the ionospheric effects should be included in this investigation.

There is an additional phase control system problem presently being studied. Relative motion between subarrays and scattering off moving, turbulent ionospheric irregularities causes "differential Doppler," which causes the pilot signal frequency to be different from the reference frequency. Thus, the power beam phase reference will be slightly in error. The ionosphere has been found to produce variations in the apparent received frequency of trans-ionospheric signals, and these variations have the same effect on the phase control system as is produced by the "differential Doppler." The ionospheric spectral broadening effect is expected to be a second-order effect, but it is a potential problem which should be investigated.

## 2.6 CONCLUSIONS

The MPTS will significantly alter the ionospheric electron temperature and density within the power beam cylinder, and the effects will probably appear at distances of 20-50 km from the beam cylinder due to drifts. F-region ionospheric irregularities will be greatly enhanced in the midlatitude regions because the natural level there is generally low. The increased irregularities will impact the coherence of the power beam, the accuracy of the beam phase control system, and the performance of both transionospheric and ionospheric-reflected communication/navigation systems. For power densities of 10-20 mW/cm<sup>2</sup> in the ionosphere, power beam losses will be small if some compensation is made for the expected variation in Faraday rotation.

## 2.7 RECOMMENDATIONS

The following recommendations are made:

- 1) An investigation must be performed to determine the mechanisms for and the extent of ionospheric irregularities which affect the accuracy of the phase control system. The system accuracy is presently being studied as a function of pilot beam amplitude and phase variations across the array surface.
- 2) A comprehensive study of plasma instability potentials should be made to determine which instabilities are possible and their probability of occurrence. Part of this work may have been done already, but no documentation was found.
- 3) A study of the interaction between the modified D-region and the mesosphere must be made to estimate the mixing effects, the potential for ozonesphere modification, and the potential for Raman scattering. The mixing and modification effects will probably be difficult to analyze because little is presently known about the natural-state interactions.
- 4) Experimental heating studies at 2.45 GHz should be accelerated when possible to verify the analytical/empirical estimates of power beam impacts and to expose any potential unexpected effects.

- 5) A workshop should be organized within the next year to (a) expose the MPTS design to the general community of atmospheric/ionospheric scientists, comm/nav system engineers, and other ionospheric "users," (b) solicit their estimates of potential impacts in each specific area of interest, and (c) compile a list of analyses and experiments to be performed with priorities and a schedule
  
- 6) Experiments should be developed to utilize the Space Shuttle platform as an observation/transmission site in conjunction with present and proposed ionospheric heating experiments (Refs. 10, 17). These experiments should also include pilot beam/phase control system evaluations where possible. Suggested experiments could easily be developed in the workshop mentioned above.

SECTION III

RECTENNA ARRAY

~~ENDING PAGE BLANK NOT FILLED~~

SUMMARY

The Impacts and Benefits to society from developing, constructing and operating the multiple ground rectenna arrays are discussed. First the functional description is given in relation to a portion of the SPS energy transmission chain. The adjacent links are the orbiting satellite as input source and the electric utility power grid as output load for the solar derived energy.

Next the detailed hardware description is given for the elements, subarrays and array as currently envisioned. This forms the basis for abstracting the impacts and benefits.

Land use, radio frequency interference, materials requirements, occupational health effects, construction and security are among the topics reviewed and discussed.

The most significant potential impact is the land area requirement. The most controversial topic is probably where the personnel exclusionary boundary ought to be, if outside the rectenna array edge.

The largest benefit when compared to present electric power generating practice, is in the very low level of waste heat liberated and lack of atmospheric emissions including noise, when compared to the useful energy delivered.

Recommendations for further study relative to better quantization and further reduction of impacts are given.

### 3.1 INTRODUCTION

The Impacts and Benefits (I&B) to society from constructing and operating the power receiving portion (Ref. 18) of a Satellite Power System (Ref. 19) (SPS) are to be outlined and discussed.

The receiving array elements are currently proposed to consist of microwave semiconductor diode rectifiers to convert the received RF energy to dc output and antennas to capture the RF and conduct it to the rectifiers. Hence the name rectannas.

The rectenna array is a part of a power transmission chain for importing energy from solar powered satellites. A current system description and previous studies are described in (Ref. 1). The chain consists of geosynchronous satellites coupled via microwave beams to the receiving rectenna arrays located on earth (Fig. 3-1). The array output interfaces with the domestic electric utility grid.

Although there are other functions related to systems operations located within the rectenna, the collection of the beamed microwave frequency (2.45 GHz) radiation and conversion to electric power output are the primary functions required of the receiving array. A 30 year design lifetime with maintenance is assumed.

Whereas the microwave power transmission link model (20) and related rectenna element engineering performance (21) are known, a detailed operational concept rectenna array design has not been performed. Thus it was necessary to develop a particular partial design in order to yield information on major sub-systems that are common to all designs. The details will obviously change with technology advance and more in-depth system tradeoffs.

The I&B derived by this approach should, however, be generally applicable to subsequent array designs.

The rectenna array will first be described in more functional detail, physical form and in operation in order for the various I&B to be derived and discussed.

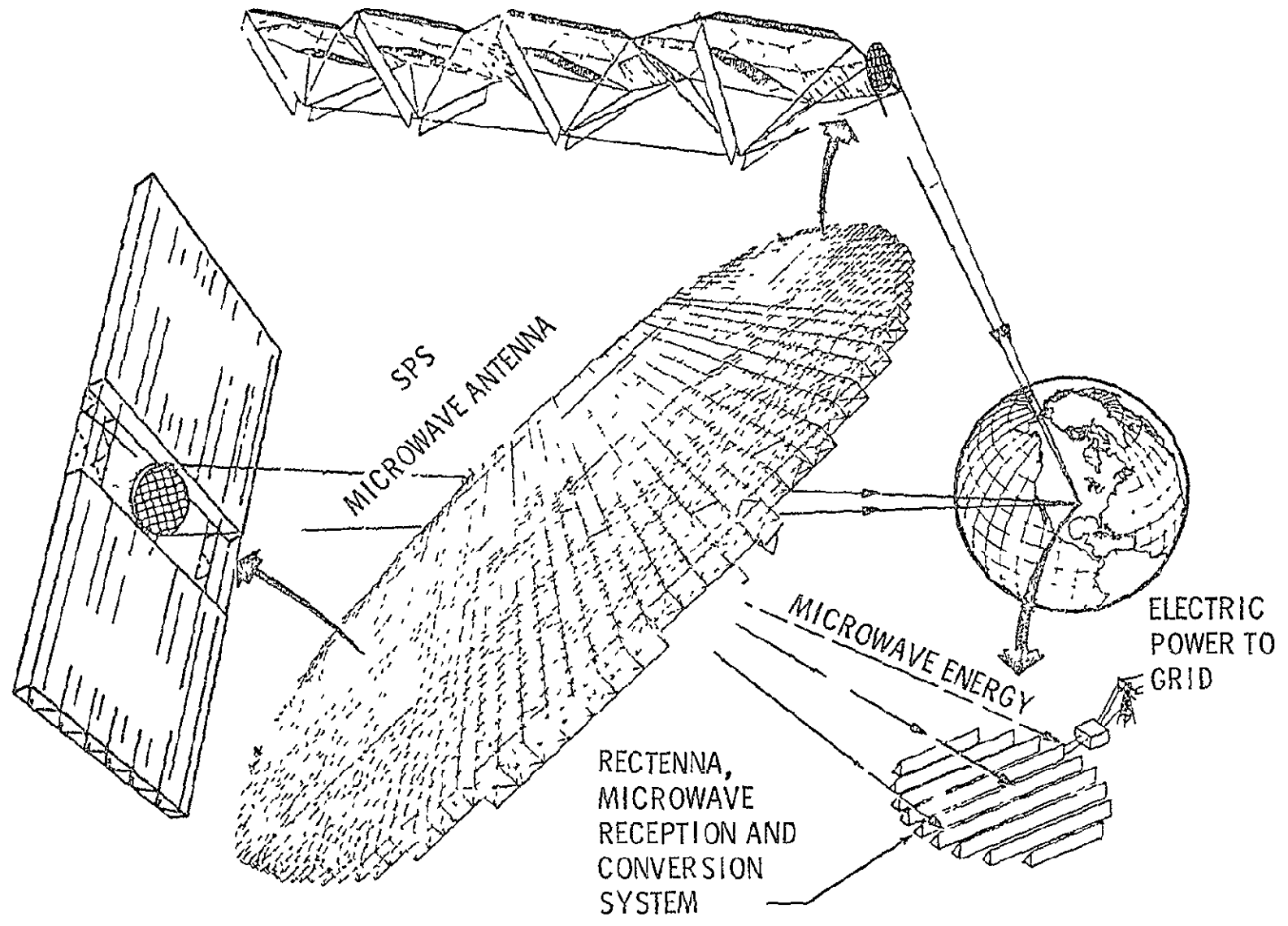

Fig. 3-1. Power transmission chain



## 3.2 THE RECTENNA ARRAY

### 3.2.1 Functional Detail

The rectenna array is similar to a ground based solar array in that in the northern hemisphere its elements face south, receive energy from out in space and convert it to electric power output. However, the rectenna function is not inhibited by clouds, dust or haze, smoke, nor is it limited to a fraction of a day in its performance.

The microwave beam input is nearly continuous except for the 1% of a year when the satellite is eclipsed, and the long wavelength (12 cm) radiation is almost unaffected by weather, thus eliminating inefficient and expensive energy storage.

The primary function of the SPS rectenna array is to collect the beamed microwave energy and process it to a form compatible with the intended loads. The loads are to mainly consist of the existing 60 Hz high voltage ac grids in the U.S. However, the array output may be processed as high voltage dc for transmission to urban load centers. Loads may also consist of dc, ac or even microwave resident or captive power users shielded and integrated into or near the rectenna.

Since most of the array output will be exported and in order to achieve improved generation security with the existing ac grid, the 5 GW array will be partitioned into 1 GW units. Thus a dispatch switching and internal load managing switching complex will be incorporated into the array.

Satellite interface facilities will also be required. Multiple coded pilot beam signals broadcast from near the rectenna center are used to enable turn on and as a phase reference for the retrodirective array in pointing and forming the power beam. A telemetry receiver and command and control transmitters must be provided for controlling the satellite. These subsystems will be incorporated in or near the rectenna site.

A resident maintenance facility will be provided.

### 3.2.2 Physical Form

The typical SPS power receiver for northern latitudes is a large elliptical outline array averaging 10.5 x 14.9 km at 38.9°, for example. For convenience in fabrication, construction and maintenance, the array is composed of smaller units termed subarrays averaging 10 x 10 m. Each subarray is composed of an array of elements called rectennas which are the basic building blocks of the array.

The rectenna element is shown in Fig. 3-2. The antenna element is a half wave dipole approximately 6 cm or 2.5 inches long. This antenna is supported approximately a quarter wavelength in front of an RF reflecting plane termed the ground plane.

The low pass filters and the rectifier may either be parallel to the ground plane reflector in front, or project through the ground plane such that the dc collection buss occurs behind the ground plane. The foreplane dc buss is perpendicular to the incoming RF electric field and thus offers a minimum perturbation or shadowing of that field.

The antenna dipole join and the close spaced parts of the low pass filters and diodes require shielding from standing water drops from dew or rain or similar foreign objects. Some form of encapsulation is necessary to prevent RF detuning effects.

The rectified output appears as a dc voltage between the dipole halves or relative to ground which is the reflecting plane.

Because of the long RF wavelength, the reflecting plane can be either partially optically transparent to promote sunlight penetration and visibility or totally opaque to provide sunlight blockage.

The rectenna elements must face the downcoming RF beam whose angle of incidence is a function of the rectenna array latitude. In northern latitudes the subarrays can be disposed as shown in Fig. 3-3a. For more southerly locations, the subarrays may be supported as shown in Fig. 3-3b. Since the rectenna's performance varies slowly with angle of incidence the rectennas can to a degree follow the local terrain undulations. Also, the loose tolerances associated with the treated wooden supports are satisfactory.

3-6

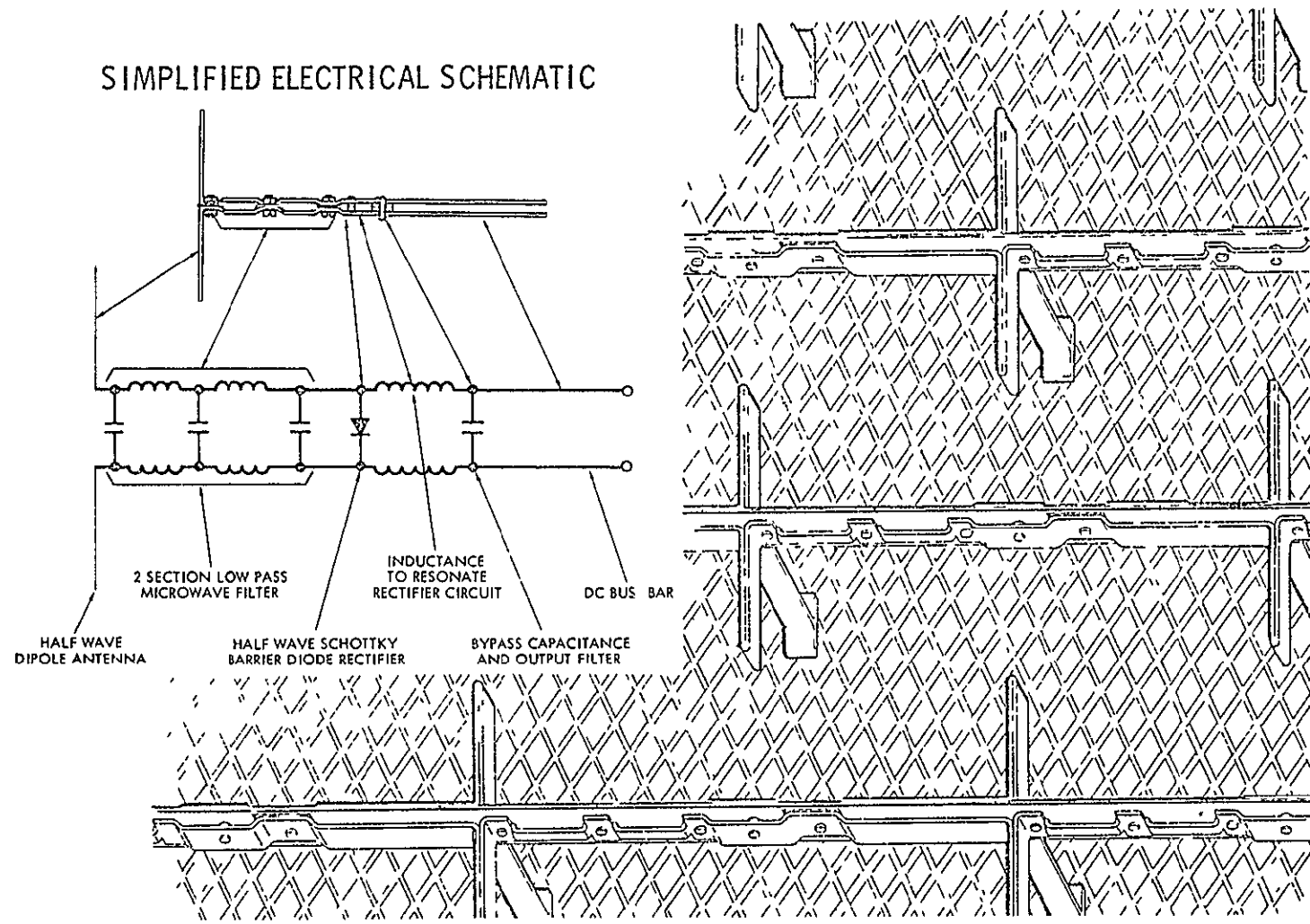

Fig. 3-2. Rectenna element and array

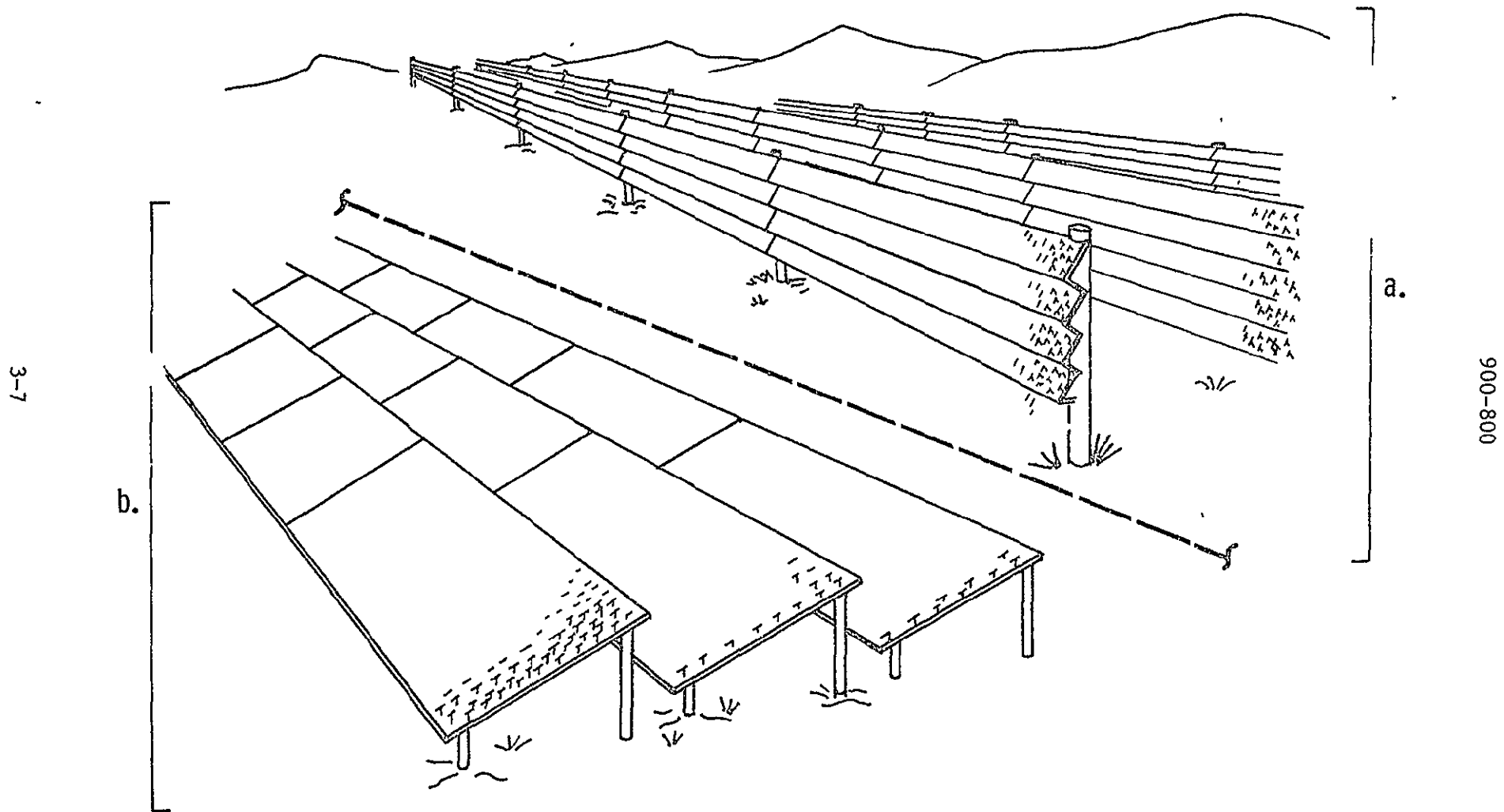

Fig. 3-3. Rectenna configurations for dual land use

An open wiring form of current collection is proposed with voltages to ground of less than 50 V in order to yield simplicity, safety and the small amount of cooling required for the efficient converters.

DC to ac inverters will be located throughout the array to periodically collect the subarray outputs. The inverters ac outputs will be further consolidated at switchyards for auto transformation to yet higher voltages and conditioned for collection and consolidation into the external utility ac or dc grids.

### 3.2.3 Operations

The rectenna is brought-on-line by first establishing communication with the utility load grid and then with the satellite to prepare for handling a throughput of power.

The coded pilot beam originating from near the rectenna array center when received and properly decoded by the satellite allows it to begin phasing its subarrays to focus the beam on the pilot transmitter.

If the spacecraft transmitter array were previously turned on and awaiting the pilot beam, then with electronic speed the beam can be formed. Thus, the rectennas must be provided with either matched loads or output voltage limiters. That is because the sudden-inertialess rectification process can cause a transient dc voltage level to be generated that could overvoltage the subarray and destroy all the diodes at once. Thus proper transient protection is mandatory. Also, a sudden turnoff or loss of load could cause similar overvoltage transients.

The rest of the ground system consisting of inverters and transformers could probably not stand the instantaneous surge of dc output. Hence either the transmitter must be brought up to power at a rate the inverters and transformers can stand or the pilot beam system must be capable of controlling the degree of coherence of the transmitter beam so as to yield a "slow" focus. The latter can be accommodated by control of the pilot beam transmitter level or transmitter modulation by design.

Once on line, the rectenna array instrumentation is sampled to determine the beam position and focus quality by monopulse techniques (Ref. 22).

Given that the rectenna subarrays and spacecraft transmitters are functioning properly, then the inverters can be initiated and the process of applying the ac or dc EHV or UHV output is programmed.

Once operating, the system is simply monitored to assure proper performance by computer testing present output data against stored standards or previous established conditions such as units down for repair or maintenance.

The quality of performance of the transmitting subarrays can be tested by electronically switching the pilot beam transmitter function from the present position to the alternate positions within the array. By monitoring the resulting beam center position shift magnitude and direction, information about the transmitter subarray phase accuracy can be derived. Similarly, the slight input change that results can be used to obtain information relative to the rectenna subarray operating quality by comparison to standard load-input performance curves.

Shutdown of the system can be electronically swift due to the inertialess response of the rectennas. If the pilot beam is suddenly removed, the flux density drops by the square root of the number of spacecraft transmitter subarrays (typically  $10^4$  subarrays). A slower controlled "grey-out" is possible by design control of the pilot level or modulation.

In summary, the rectenna array may be a large collection of small microwave antennas and associated rectifiers grouped into subarrays supported on treated wooden supports. The subarray dc electrical outputs are collected into ac inverters whose outputs are consolidated into transformed high voltages for final conditioning as EHV or UHV ac or dc before feeding into electric utility grids. The rectenna array physical plant also contains a maintenance facility and interface equipment associated with the spacecraft and the utility grid.

This brief description has provided the background for more in-depth discussions of rectenna array details wherein impacts and benefits will be discussed.

### 3.3 IMPACTS AND BENEFITS

#### 3.3.1 Land Use

Like sunlight, the diffuse microwave radiation requires large collecting areas to be effective. The overall land use requirements of the SPS rectenna will probably be determined by the applicable personnel flux density regulations in force at the time of construction. The currently allowable personnel continuous exposure limits for microwave radiation within the U.S. is  $10 \text{ mW/cm}^2$  [ANSI C95.1 via OSHA].

For the current SPS designs having 5 GW rectenna output, the  $10 \text{ mW/cm}^2$  flux density level is reached at a radius from the center of the rectenna array at about 3 km. Economically useful rectenna collection occurs out to a radius of about 5 km, depending on the transmitter aperture illumination taper, in order to intercept about 95% of the beamed energy. Aperture taper refers to the spacecraft transmitting antenna design practice of making the microwave flux density in the center greater than at the edge in order to reduce the radiated sidelobe levels. Figure 1-4 shows the effects of taper on the antenna patterns.

The flux density at the rectenna edge is on the order of  $1 \text{ mW/cm}^2$ . Thus, the rectenna edge flux density level is 1/10 the current U.S. allowable continuous exposure. This is also the maximum allowable microwave emission level, before purchase, 5 cm from the door of a consumer microwave oven (Ref. 23).

The sidelobes of radiation from the satellite transmitting antenna which contain the remainder of the radiation, all fall outside the rectenna for transmitting antenna aperture illumination tapers greater than 10 dB. Even with uniform transmitter aperture flux density or 0 dB taper, the first sidelobe on the earth is 17 dB below the peak radiation or  $0.45 \text{ mW/cm}^2$ . The current designs of 10 dB taper yield a first sidelobe level of  $0.085 \text{ mW/cm}^2$  for example.

Some East European, Soviet countries have an even lower allowable continuous personnel exposure flux density limit such as  $0.01 \text{ mW/cm}^2$ , and in all probability the existing U.S. levels may be revised downward.

In case the level was set at  $0.1 \text{ mW/cm}^2$ , a factor of 100 lower than at present, a taper of greater than 9 dB would be required to keep the first sidelobe lower than that limit. The personnel exclusionary zone would then be a radius of about 8 km from the rectenna center. For a  $0.1 \text{ mW/cm}^2$  constraint, then

the boundary would be about 3 km beyond the rectenna edge since the main beam narrows only slightly. Land requirements would thus be  $(8/5)^2$  or 2.5 times the rectenna receiving array only requirements!

However, with the current design 10 dB taper, the sidelobe level is reduced, the main beam widens only slightly and the  $0.1 \text{ mW/cm}^2$  contours recede to only 5.8 km from the rectenna center or 0.8 km outside the rectenna edge. Hence, for the 10 dB taper baseline case, the land requirement is only 35% more.

If the personnel exclusionary zone around the rectenna were required to be  $0.01 \text{ mW/cm}^2$  (1000 times below current U.S. limit), then for the current 10 dB taper case, the boundary would be at a radius of about 14 km or 9 km beyond the rectenna edge, requiring 8 times the rectenna area! A greater than 15 dB taper in the transmitter could move the zone boundary into the first sidelobe at about 9 km radius where the land use would be slightly more than three times the rectenna area. The higher taper leads to elevated waste heat concentration on the spacecraft transmitter array however, and thus requires a system design tradeoff.

Three times the rectenna area is considerable land area in the U.S. for the scenario of 224 each rectennas in the U.S. from 112 satellites. The basic rectennas are elliptical in outline due to the northerly latitude locations and the equatorial orbit spacecrafts. Assuming an average  $45^\circ$  angle of incidence on the rectenna which occurs at about the latitude of St. Louis for example, the average rectenna eclipse of 5 x 7 km radius would have an area of  $110 \text{ km}^2$ . Two hundred twenty-four each would be  $2,464 \times 10^4 \text{ km}^2$  or 0.26% of the land and water area ( $0.368 \times 10^6 \text{ km}^2$ ) of the 48 United States. An area slightly more than Vermont for the basic rectennas in the proposed scenario.

If the rectennas were distributed such that no sidelobe overlap of consequence occurred, then for the case of  $0.1 \text{ mW/cm}^2$  exclusion boundary, the 224 sites would be 35% more or about 0.35% of the U.S. land and water area.

The 15 dB taper,  $0.01 \text{ mW/cm}^2$  case, under similar restrictions, would require approximately 0.8% of the U.S. area or slightly less than So. Carolina or Maine in area.



If overlap of sidelobes were to occur, as for example if rectennas were to be grouped into "power parks," then the superposition of sidelobes would be such as to require more land than individually. Their superposition would not be appreciably more for a high flux density regulation, but would be for a low level requirement. For example, two 15 dB taper beams overlapping at a common point at 17 km radius, in the third sidelobe, could raise the flux density to the  $0.01 \text{ mW/cm}^2$  level, whereas individually that level would normally be reached at only 9 km radius. This is the extreme ratio case and many closely packed rectennas would not create such long range effects, but the net result is still that grouping rectennas does require slightly more land use than individually.

It is instructive to consider another extreme but interesting case wherein all the rectennas are grouped together. Away from the main beam and close in sidelobes, because of transmitting array operational phase errors, failures and amplitude errors in the subarrays, the transmitting antenna pattern sidelobe level will fill into an average error level until the basic subarray pattern envelope further reduces the sidelobe level.

If many beams were put into close proximity, then the superposition of this average error level could exceed perhaps the  $0.01 \text{ mW/cm}^2$  flux density level. For example if 25 beams, each of which had  $10^0$  rms phase errors,  $\pm 1$  dB amplitude errors and 2% random subarray failures were within 100 km radius of each other, the combined flux density could exceed the  $0.01 \text{ mW/cm}^2$  limit throughout a 200 km diameter circle. That would represent an area 11 times the rectenna combined areas. All 224 beams in a 300 km radius would exceed the  $0.01 \text{ mW/cm}^2$  limit.

Figure 3-4 indicates the range of land usage from the basic rectenna array to the  $0.01 \text{ mW/cm}^2$  exclusionary zone as a function of the clustered rectennas. An exclusionary limit higher than the  $0.01 \text{ mW/cm}^2$  figure would yield maximum land usage requirements that are much closer to the basic rectenna land usage.

Thus, the rectenna land use requirements are closely coupled to the exclusionary zone flux density limits, the degree of clustering, the quality of the transmitting arrays and the aperture illumination taper in the transmitting array.

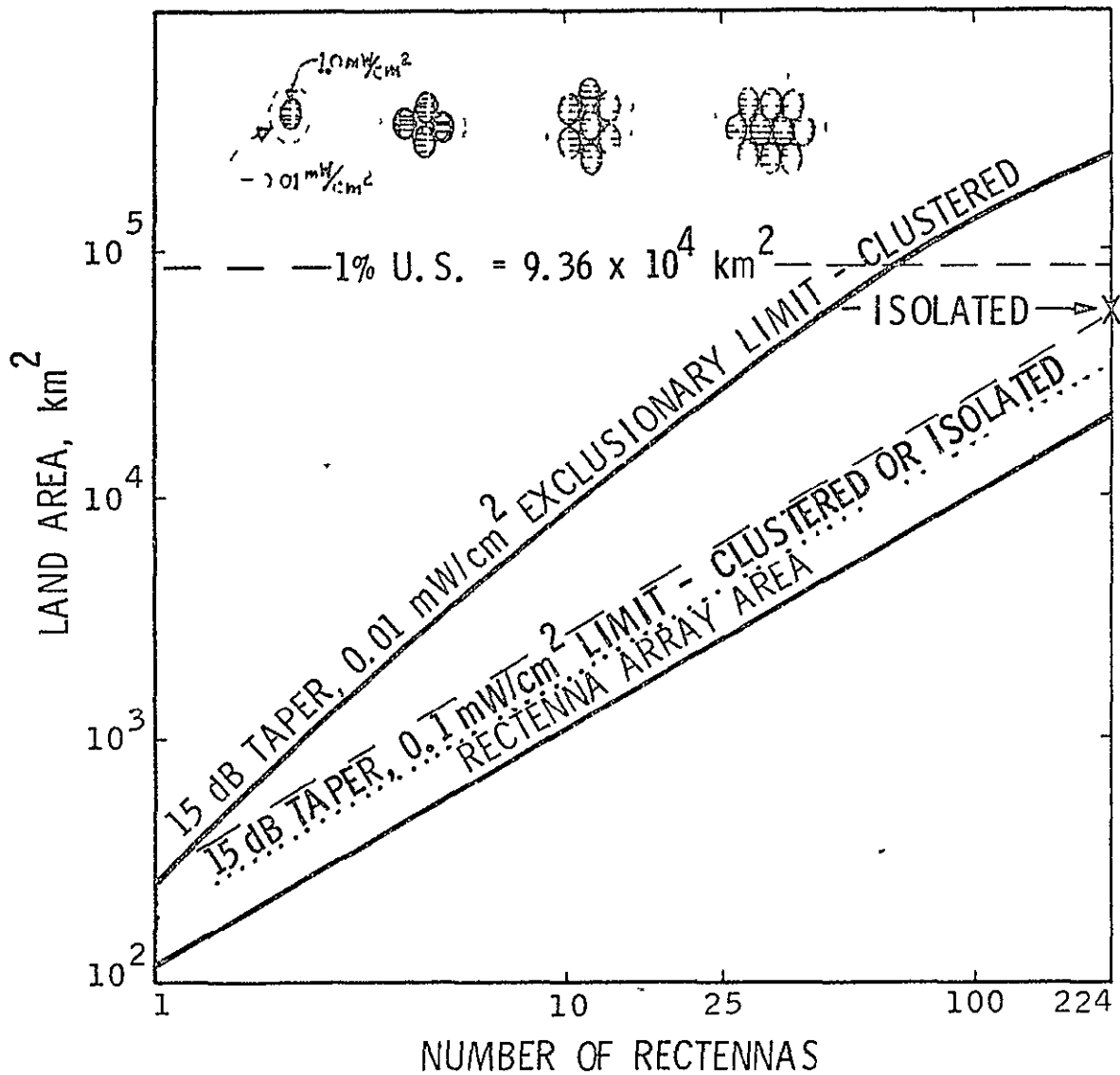

Fig. 3-4. SPS rectenna land requirements

A fenced guard ring may exist around the rectenna array collectors either for physical plant protection or for assistance in maintaining the microwave flux density personnel exclusion. However, the guard ring land could also have dual use in that it may be pastureland or for other agricultural use or as a wildlife sanctuary. A portion of the utility grid interface equipment and perhaps the shielded maintenance facilities could also be in the guard ring along with shielded captive load industries.

These dual land uses tend to mitigate the spacious SPS land use, but the fact remains that large land areas are necessary for a rectenna derived electric power supply system.

The tradeoffs involving rectenna array and transmitting array size vs the beam power transfer efficiency are shown in Fig. 1-3. For a desired beam transfer efficiency, the product of the area of the arrays at the two ends of the link is a constant if the wavelength and range are fixed. Figure 1-3 also shows that in order to achieve the optimum beam efficiency, the microwave energy must be distributed across the transmit and receiving array in a prescribed aperture taper.

In the ideal case, the radiated beam energy distribution can be described as contained within a conical cylinder extending from the satellite to the rectenna. The conical angle of the cylinder is a function of the size of the transmitting array in wavelengths and hence determines the size of the rectenna. In the overall system design tradeoffs, the ground array is made larger than the spaceborne array in order to minimize the spacecraft weight and thus cost.

The rectenna array has also to be large enough to capture most of the microwave beam as it moves about on the ground due to system pointing errors. Although in the case of the pilot beam steered retrodirective array the beam center movements are expected to be less than 40 to 50 meters.

Thus the land use requirements for the rectenna collector arrays alone are large and other regulatory boundaries are particularly sensitive to the allowable flux density levels set for continuous personnel exposure.

Shared or multiple land use is feasible for certain enterprises both within the rectenna field and in the personnel exclusionary zone or guard ring. These uses will be discussed in connection with the rectenna subarray impacts.

In order to locate rectennas close to urban centers and to accommodate the land area required in the 112 SPS scenario it could in some instances be necessary to displace people or to provide them with an RF shielded existence. However, as 2/3 of the people in the U.S. are currently located in the 1/3 of the U.S. east of the Mississippi, it would probably be better to locate most of the rectennas in the west where the land is, and then export the electric power east via HVDC lines like the present Pacific Intertie.

The more abundant western sunshine and land shadowing subarrays may be a beneficial impact in some agricultural cases, but the fact remains that the system total land use is the largest rectenna impact.

It is not yet known whether airspace restrictions will be required. The transient aircraft passage may be impacted via increased noise in their avionics subsystems. The loitering canvas sailplane or plastic bubble helicopter should be excluded from the beam center due to possible personnel dehydration for long exposures.

### 3.3.2 Radio Frequency Interference

Aside from land use impacts, the other significant impacts relate to the RF energy that is not collected either by design or other causes. The uncollected energy may affect biological safety but it particularly represents an RFI impact via receiver saturation or intermodulation product generation.

Uncollected RF energy results from rectenna spillover by design (uneconomical to process), beam reflections, beam misdirection or harmonic reradiation. The conditions that lead to reflected energy arise both from natural causes and nonstandard operation of the transmitter, rectennas, or load.

Proper optimization of the rectennas subsystem design is required to minimize the RFI impacts. The applicable parameters can best be understood by a detailed discussion starting with the beamed power system.

3.3.2.1 Beam Pointing. The system source input to the rectenna array is the microwave energy beamed from the power transmitting array aboard the satellite.

One function of the satellite interface equipment in the ground array and another potential source of the SPS Microwave subsystem RFI, is the provision for transmission of a coded pilot beam

The pilot signal is received by the subarray receivers of the satellite retrodirective phased array and is phase processed in order to derive the array beam pointing information. The power beam is automatically, electronically steered to focus on the pilot beam transmitter.

Coding is employed to deter theft or misdirection of the power beam by unauthorized transmitters. The degree of difficulty in pursuing the latter course is a function of the spaceborne receiver design. The "ante" to get into the game can be made quite high in terms of the pilot beam pointing accuracy, signal absolute power level, and the complexity of coding modulation and demodulation.

The power level of the pilot beam transmitter is a rectenna RFI impact, and in the extreme case, a very powerful pilot beam transmitter could be cause for any added airspace restrictions. Multiple pilot transmitters are desirable and diversity switching could reduce such airspace impacts.

Figure 1-4 shows the cross section of the distribution of flux density within the incident microwave beam for the baseline design. On the average, the flux density will be distributed over the rectenna as in Fig. 1-4. The center of the the beam will fall on the center of the array most of the time. However, due to the environmental factors and because of most of the engineering limitations as shown in Fig. 3-5, the center of the beam will move about the center of the array.

The current design constrains this beam wander or dancing to on the order of 40-50 m. This is fine pointing for something originating 37,000 km away! The fine pointing is achieved by use of the pilot beam steering retrodirective array technique mentioned previously.

3.3.2.2 Propagation Conditions. Propagation conditions play a part in determining rectenna impacts. Large scatterers in the beam will cause increased RFI on the ground and in air and space about a rectenna. Such scattering sources could be meteors, other spacecraft, ionospheric storms, aircraft, lightning, flocks of birds and insect swarms (radar "angels").

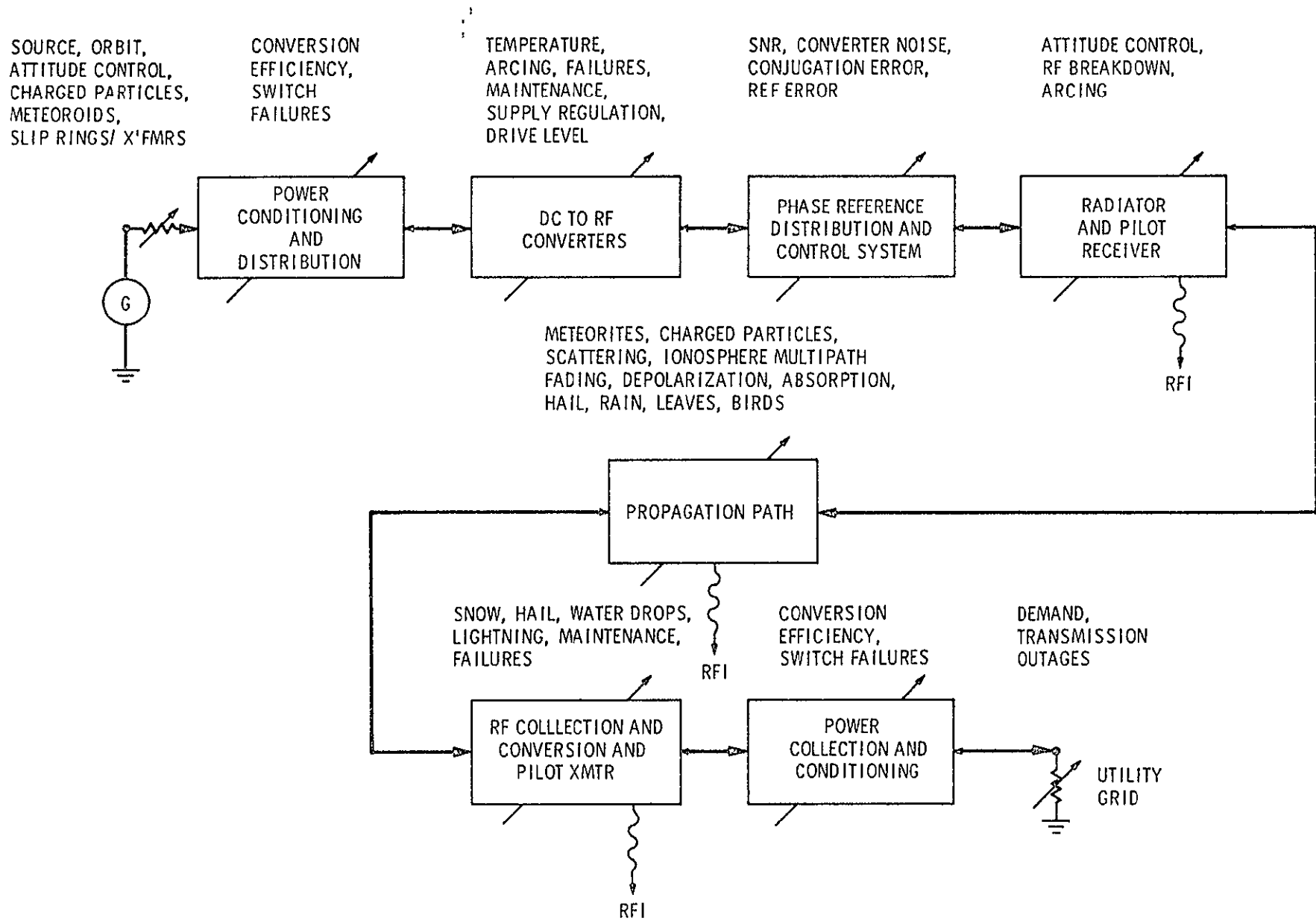

Fig. 3-5. Factors affecting microwave power transmission power levels

. Severe weather conditions can lead to large precipitation forms such as wet hail that can cause scattering and absorption of microwave energy. Due to the rather long (12 cm) wavelength, normal raindrop sizes do not lead to significant scattering or absorption. The rapid refractive index gradients associated with severe weather fronts provide some scattering. However, the above effects are rather infrequent and the magnitudes of scattering or loss rarely exceed 5%. Negligible for biological concerns, but not for RFI impact considerations.

Depolarization of the power beam is a system performance as well as an RFI impact. One natural cause is solar storms, whose charged particles and trapped magnetic fields alter the earth's magnetosphere and ionosphere (Ref 24). This in turn affects the state of polarization of the microwave power beam and pilot beam and leads principally to other than optimum received polarization at the rectenna (unless successfully tracked out by orienting the spacecraft). That fraction of the RF energy that is incorrectly polarized is reflected and radiated back into space by the rectenna.

The interaction of the pilot and power beams in the RF heated ionosphere represents a potential impact on the beam pointing system accuracy. The heated ionosphere is an impact on other RF signals traversing that region. Modulation transfer and harmonic mixing can occur. This can impact other ionosphere users as well as the SPS command and telemetry signals.

3.3.2.3 Conditions at the Rectenna. The RFI impacts of the rectenna per se are principally due to rescattered incident radiation and harmonic generation and radiation. A portion of the incident radiation is rescattered that depends upon many factors. First is the state of polarization of the incident wave as affected by the spacecraft alignment, the ionosphere and the rectenna array construction and maintenance accuracy.

Thus, if the incident wave polarization is mismatched to the rectenna receptors, some energy will be rescattered. The direct and crossed polarized rescattering patterns are unknown at present.

The state of the effective RF load presented by the rectenna affects the amount of reflected energy. Thus, if the incoming flux density is less or more than designed for, the diode effective impedance is varied and the RF match is improper.

Incorrect incident flux density levels such as may be caused by transmitter failures, the slight system beam mispointings, or trash blowing across the rectennas such as leaves, tumbleweeds, paper, etc., can also diminish the amount of RF energy reaching the rectenna. Though small in terms of the output electric power, the scattered energy represents RFI potential impacts.

Even with properly polarized and pointed and correct level RF energy, there may still be reflections due to improper RF impedances caused by load variations. Figure 3-6 shows the magnitudes of some of the factors affecting rectenna re-radiation RFI levels.

Conditions that affect the RF impedance match can also be cause for reflected power. If significant dust or water layers or insect nests, bird droppings, weeds, leaves, seeds, etc exist near the tuned antenna elements or RF filters, then the added stray capacities can cause an RF impedance mismatch which will lead to reflected energy. Bent elements due to hail impacts or bird or animal curiosity or nesting; mis-oriented subarray panels due to wind, earth movement or setting, or missing rectenna due to terrain defiles can also cause reflected energy. Deposited leaves, twigs, tumbleweeds, vine overgrowth, wet snow, hail, resting or nesting birds, animals or insects can also cause detuning of rectenna elements that result in reflected power.

The exact pattern of energy reflected from the rectenna array is currently unknown. However, the energy is expected to be somewhat uniformly distributed throughout the basic rectenna dipole pattern. Thus, a majority of the energy will be reflected back toward the spacecraft. Nonetheless, there will be significant radiation directed toward the southern horizon.

The rectenna elements in a subarray are wired in parallel to promote self-clearing of faults (shorted diodes) by fusing open the small bond wire to the diode chip. Thus, if a diode faults, it is automatically cleared via the combined short circuit currents of the paralleled diodes. Nevertheless, some incident RF energy is now reflected from the cleared fault antenna. Thus, the state of maintenance can affect the amount of reflected power and thus RFI impact. Also, when subarrays are removed from service for repair or maintenance, and they are in either a no-load or short-circuited condition, then the



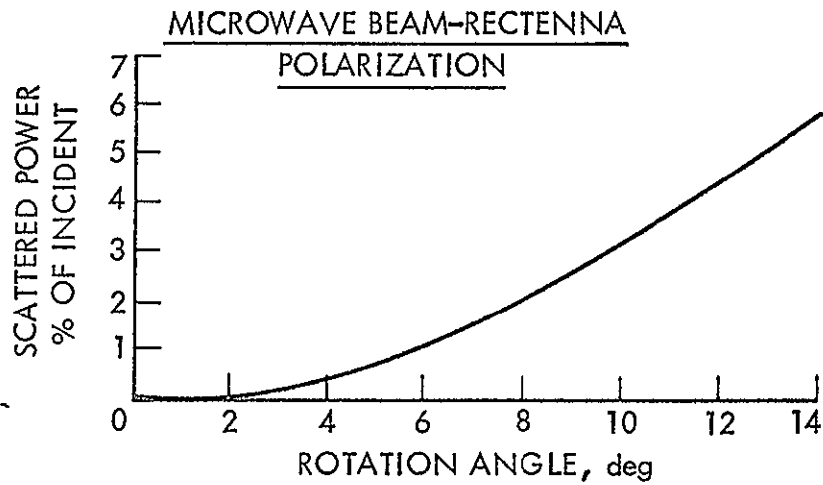

- a. SOLAR STORM FARADAY ROTATION
- b. SATELLITE ROTATION
- c. MISALIGNED RECTENNA DIPOLES

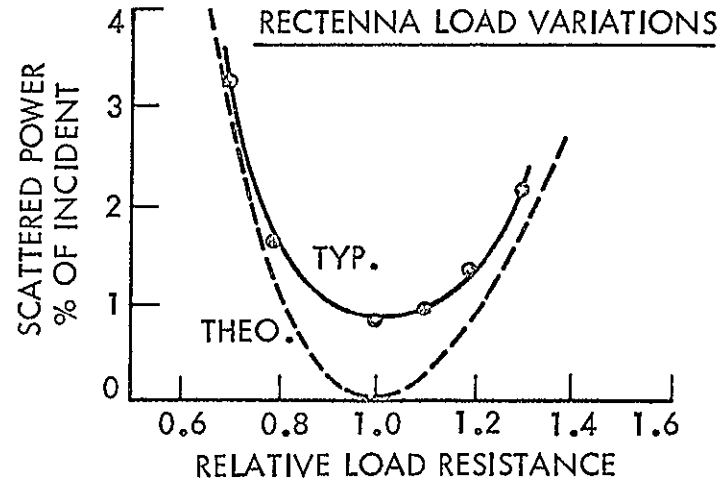

- a. UTILITY DEMAND
- b. RECTENNA OUTPUT COLLECTION MGT.
- c. RECTENNA MAINTENANCE

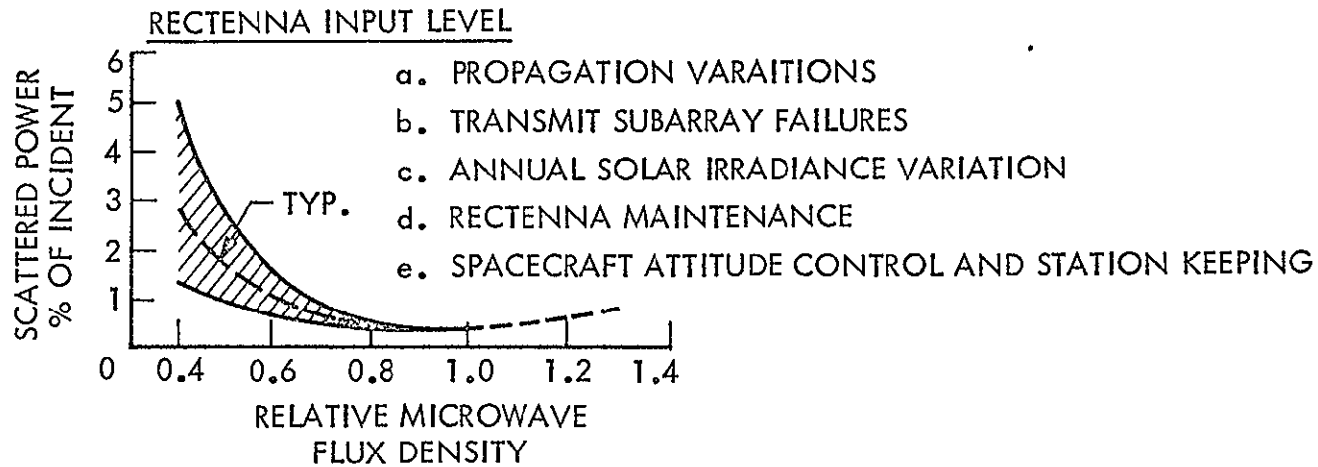

Fig. 3-6. Factors affecting rectenna re-radiation RFI levels

reflected energy density above the subarray can be locally quadrupled due to constructive interference near the subarray caused by the incident and almost totally reflected field strength.

During the transient conditions associated with turn-on and turn-off of the system, the rectenna will reflect the low level incident radiation.

3.3.2.4 Harmonic Reradiation. In addition to the fundamental energy at 2450 MHz, the rectenna will also radiate harmonics. Current rectenna harmonics are 2nd - 25 dB down from the fundamental, 3rd - 40 dB down, 4th and higher greater than 70 dB down. The harmonics are caused by the nonlinear current flow in the diode. The harmonic currents are trapped by the rectenna low pass filters (Fig. 2), LPF, in order to promote high conversion efficiency. However, there is a system tradeoff relative to keeping the LPF fundamental insertion loss low which tends to limit the number of filter sections for harmonic rejection.

The angular radiation pattern of the rectenna harmonics is currently unknown also. The harmonics can potentially impact both ground and space users of the spectrum.

3.3.2.5 Other RFI Sources. The dc to ac inverters with their switching harmonics are a potential source of RFI impacts unless properly filtered. The subarrays and collection lines can become potential arrayed, low frequency antennas with the potential for sharp angular lobed patterns unless the harmonics are suppressed or purposely dephased.

In addition to the pilot beam signal and the subarray line carrier instrumentation, the command and control transmitters are potential RFI sources.

High voltage corona noise is a potential RFI impact source as well as an acoustic noise source.

The small amount of waste heat liberated by the rectennas, inverters, transformers and transmitters appears as infrared (IR) radiation RFI.

Reflected sunlight from the field of subarrays is also an RFI impact as it may affect spacecraft optical sensors or aircraft pilot visibility.

Reflected moonlight from such a large surface may make an impact on migrating waterfowl if they misinterpret the shiny subarray surfaces as a large

body of water during restricted visibility conditions or otherwise

In summary, the beam incident on the rectenna and the rectenna itself are sources for scattered and originated microwave radiation whose RFI potential can affect ground, aircraft and spacecraft receivers at a number of frequencies. The strongest are the pilot and power beams and harmonics. Their level and impact is to a degree a function of the rectenna maintenance.

The actual impact details are obviously a function of where the rectenna is located. If trees can be grown around the rectenna perimeter, it may be possible to absorb much of the horizon directed microwave radiation for example.

### 3.3.3. Materials Requirements

The various types and quantities of materials required for a rectenna are obviously a function of the design. The JSC (1) scenario design simply assumed aluminum and concrete for the rectenna support. However, the resulting absolute magnitude of each is quite large. Thus, this report turned to an alternate renewable resource for its rectenna support that generally does not require footing preparation.

In this report, treated wooden poles are assumed to support the subarray reflectors, and for the case of an opaque subarray, the metallic film ground plane is assumed to be deposited on a laminated, pressed formed wood backup structure. Thus, the aluminum is reserved primarily for the rectenna elements and dc and ac collection lines. Hence, the rectenna requirements for non-renewable resources such as metals and concrete can be quite reasonable by proper design. The wood can be treated for fire retardation and preservation against insects and fungus.

The thin film ground plane subarray version requires two wire collection of current, whereas the perforated or wire mesh screen version can use the ground screen reflector as one buss for the collection of current from rectenna elements.

For effective RF performance, if the ground plane is composed of wires in a grid or holes or other perforations, the openings can represent up to about 75% optical transparency at normal incidence before the RF leakage to the

back side approaches 1/2%. The dipoles and dc collection buss further reduce the optical transparency to ~60%.

The opaque ground plane can be a very thin metallic film. Only enough material is required that the RF wave impedance mismatch be sufficient to achieve significant reflection. Vacuum deposited metallic films of 1/60 skin depth thickness can yield up to 99.6% reflectance (25). For aluminum at 2.45 GHz, the corresponding thickness is 275 Angstroms.

A further detailed discussion of the rectenna and power collection scheme will serve to bring out the various material requirements so that resource impacts may be evaluated. The auxiliary facilities, alternate loads and maintenance plans will also shed further light on materials requirements.

3.3.3.1 The Rectenna Element and Instrumentation. The rectenna element consists of aluminum conductors, low-loss dielectrics, Gallium-Arsenide-Tungsten Schottky barrier diodes and aluminum or galvanized steel wire mesh ground planes and current collecting lines. The collection voltage is designed at no more than 50 V to ground in order to allow open wiring for simplicity, cost effectiveness, safety, and the small amount of cooling required for the efficient converters. Higher voltages would require shielding of switching and placing the collection lines in conduit and personnel restraint from the antennas, for a much more non-renewable material intensive design.

Since there is a range of over 20 to one in incident power flux density over the array, there will be techniques for accommodating the variation. The rectenna element low pass filter and diode impedance matching filter will be designed to be set adjusted at assembly to transform the low intensity microwave voltage to a load to yield 50 V output. Thus, all rectennas have the same amount of material.

The RF sensitive portions of the rectenna element will require weatherproofing. Standing water drops due to rain or dew on the bare antenna and filter elements will detune the circuit and increase the reflected power and losses. Dry snow will have a lesser effect until it begins to melt. Thus, some form of encapsulation is necessary around the sensitive filter-diode part of the rectenna. The antenna dipoles must remain exposed in order to efficiently intercept the beamed radiation. A combination of aluminum and low loss

dielectric encapsulant will add to the rectenna materials list. Conformal coating at the junction of dissimilar metals may be required.

3.3.3.2 The Subarray Subarrays are the next larger rectenna building blocks after the elements. The subarray is a large collection of rectenna elements grouped into a convenient size determined by fabrication shape, current conductor diameter latitude and other similar requirements. The subarrays are designed to be supported on treated wooden supports (laminated columns or poles) with a height limitation of about 10 m so as to fall within simple construction code practice, to use normal electric utility techniques and hardware, and to maintain a reasonable growth time for the trees from which the supports are to be processed so as to limit the renewable resource impact.

The electric utility industry used approximately 3 million unlaminated poles in 1975 (Ref. 26) at a cost of \$40 each. A rectenna would require approximately 2 million supports. However, laminated columns can effectively be made with shorter discontinuous timber products. The collection of rectenna elements can be disposed as shown in Fig. 3-3. The stair-step configuration of Fig. 3.3a in the opaque ground plane version is provided with lateral stiffness due to the "pleated" shape. Thus long spans can be supported. The limit to span length is about 35 m due to thermal expansion considerations. The transparent screen version will probably require intercostals to make 10 m separations.

The current collection buss wiring will be tailored to handle the accumulating current. Diagonal interconnections of paralleled diode outputs will promote convective air cooling. The minimum collecting wire size is No. 18 in order to provide adequate rectifier diode cooling, but larger sizes are necessary as added strings of outputs are paralleled.

The transient overvoltage protection device or circuit will probably be placed at the common output of each subarray where the current is gathered for bussing to the inverters. This junction will also contain the subarray voltage and current monitoring instrumentation. The data will probably be modulated on a carrier frequency on the current collection lines and assimilated at the EHV conditioning equipment sites.

The subarrays can follow the undulation of terrain at an array site by use of various height and spacings of supports. The occasional misalignments of the rectennas can be tolerated due to the low angular pointing sensitivity of the dipole antenna element. This also accommodates the satellite station keeping. Thus, rolling or gently sloping land is suitable, but severe terrain would lead to inefficiencies or the use of longer length structural supports to tile the projected plane from the spacecraft beam.

RF "shadows" in which to place auxiliary equipment such as transformers or switches or to provide access, can be produced by the use of extra tall subarrays, perhaps supported on the overhead high voltage ac collection line towers.

The rectenna absorbing panels could be installed off the ground to allow communicating access among the poles for certain animal husbandry or agricultural operations in dual land use schemes. The low dc collection voltage on the subarrays is compatible with such activities. Either taller supports or closer spacings could accommodate the raised lower edge of the subarray required for tractor or horn height clearance. Noncontinuous, but occasional clearance access schemes could also be designed to allow the majority of subarrays to come within 1 m of the ground. One meter minimum ground clearance is necessary for maintenance activities and damage minimization.

Sunlight penetration can either be promoted or arrested, depending on the type of ground plane and in the case of the partially transparent ground plane, the sunlight scattering qualities of the subarray rear face are important.

The roofed over subarray configuration of Fig. 3-3b will be more desirable in those cases wherein maximum RF shielding effectiveness is desired, as some small amount of RF will filter through the cracks in the separated subarrays due to edge diffraction and also there will be some small rescatter into the area between separated subarrays due to load, polarization or input intensity mismatch.

The wire grid or perforated metal reflecting plane subarrays desired to promote insolation will require periodic support frames. It is proposed that these frames also be of that renewable resource, laminated wood, rather than aluminum or steel.

Terrain blending colors could also be incorporated into the opaque subarray surface if the proposed location is such as to be in high visibility. Also, particular surface finishes or treatments may be desirable to promote a thermal net balance for the overall array by modifying the local albedo to promote infrared radiation.

The usual utility pole hardware is proposed to fasten the subarrays to the supports. Except in marshy locations, there is no requirement for additional treatment of the post holes.

3.3.3.3 Auxiliary Facilities and Alternate Loads The subarray outputs will be periodically collected on a current buss leading to dc to ac inverters. The inverter outputs will be collected on a higher voltage buss leading to transformers wherein the collection-transformation process is repeated again until the ultimate transformers and converters which are used either to output 60 Hz high voltage or directly to the EHV or UHV grid or where ac to dc converters are used to output HVDC to a dc EHV grid.

The internal transformer voltages may be as high as 230 kV and still use a wood-pole and timber-structure configuration (Ref. 27).

Also, by holding the first, lower voltage collection levels to below 34 kV, the equipments can be simply "hot stick" switched out for maintenance or repair.

The very heavy switches and transformers will require concrete foundations. Crushed rock and railroad rail supports for some of the smaller apparatus is feasible, however. The tall transmission towers at UHV or EHV connecting SPS power to urban loads will be of steel or aluminum with concrete footings. Applicable substation design materials listing and costs exist for amassing materials impacts (Ref. 28). A minimum materials optimization has not been done in this limited effort, however the results should yield an advanced view of the total relative to the JSC scenario.

The subarrays will require maintenance and a resident maintenance facility for housing personnel, vehicles, supplies and spares will probably be located near the rectenna edge.

The array will also contain a telemetry receiving and command and control transmitter complex for interfacing with the satellite. These major sub-system areas are shown in Fig. 3-7. The redundant pilot beam transmitters antennas can be integrated into special rectenna buildings near the array center with sloping sides or roofs. They may be further diplexed to receive the telemetry and to radiate the commands, also.

Similar sloped sided or roofed buildings may be used by any of the captive or integrated ac, dc loads within the array, either for rectenna complex power requirements or for leased revenue producing loads.

For those site integrated loads that use microwaves directly (Ref. 29) as process heat in noncontacting operations, a different form of microwave collector is necessary to introduce the rather diffuse energy into a waveguide in order to have concentrated high intensity microwaves for industrial process applications. More than likely, a parabolic trough collector of wire mesh with a slotted waveguide collector feed would suffice.

The captive loads that require higher voltage dc may have special rectenna subarrays wired to place most of the elements in series in order to achieve the high voltage. The normal small spacings of the rectenna element parts will limit the maximum dc voltages to several kV before breakdown. However, the inefficiencies associated with the dc to ac to dc inversion-conversion process may be bypassed in this scheme, with perhaps some materials savings.

As was mentioned previously, the rectenna array export power will be partitioned into perhaps 1 GW sections in order that the utility grid into which they feed can manage the size of the block of power. The switchyard and breakers associated with the design for flexible routing must be accommodated within the total rectenna physical plant along with the microwave and carrier communication terminal equipment associated with dispatch and fault control.

Power must be imported to the rectenna site during outages caused by eclipsing of the satellite or other outages. This standby power is necessary to maintain control and data processing communication channels, switching power and the pilot transmitters in order to restore satellite transmission. The impact



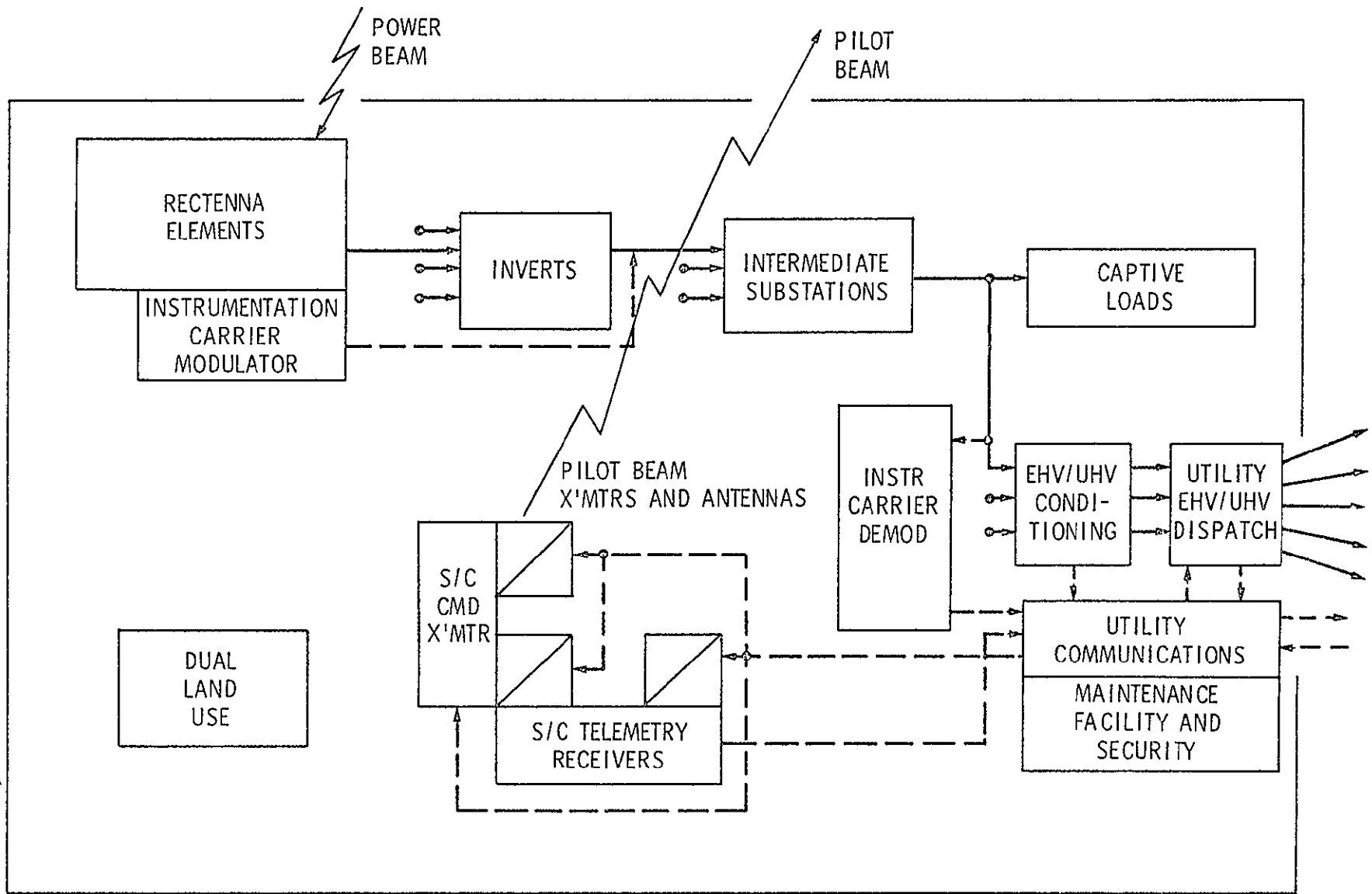

Fig. 3-7. Rectenna subsystems

of this power requirement is small as it can be accommodated via the existing rectenna export power lines.

The overall rectennas will be provided with an instrumentation system to allow collection of subarray and inverter performance data. Also, the status of various switches must be logged or monitored, and methods of control must be made available to accommodate loading patterns and scheduled maintenance or repair removal of subarrays or sections from service.

The data on power output from various areas of the array can be processed in a monopulse fashion to very accurately indicate the centroid of the incident microwave beam.

The impact of the instrumentation is to require more expensive electronics and create added RFI potential as the carrier line data may be radiated.

3.3.3.4 Maintenance. Because of dust and debris accumulation the subarrays will require periodic cleaning for foreign object removal. Air blown or vacuum removal may be adequate for most cleanings, but periodically water washing will be necessary if rains are not satisfactory. Snow drifts may need leveling. Hence, the array must have provisions for vehicular mounted maintenance gear to traverse the area. If the joint tenancy is with agricultural operations, the cleaning and irrigation functions may be combined.

Other surface maintenance requirements such as painting, etc., for albedo absorptivity and reflectivity, color blending, or insulation maintenance will have to be factored into the overall maintenance schedules and plans.

Weed, brush, tree and vine trimming around the subarrays and high voltage ac equipment will be necessary periodically. Depending upon location, tumbleweed removal may be necessary.

3.3.3.5 Materials List. See Table 3-1 for the support structure wooden materials required in a worst case snow, ice and wind load design rectenna array. Also note that the renewable resource approach does not require any footings except in marshy terrain.

Table 3-1. Wood Rectenna Support Structure

Structural Element	Number Lengths	BD Ft/Ft <sup>2</sup> BD Ft/Ft	PSF P/Γ	Per 40' x 40' Subarray		Array (582,531 Subarrays)		
				BD Ft	lbs	BD Ft	Lbs	tonnes
3/8 in. Plywood 4' x 8' exterior	27 5 shts	0 375	1 151	330	1013	1 9224E08	5 901E08	267,667
3 x 6 Glulam joists x 40' (4 LAM)	21	2.0	4 0	1680	3360	9 7865E08	1.9573E09	887,819
2 x 6 Blocking 8 x 34-3/4'	Equiv	1 0	2 2	278	612	1 6194E08	3 5651E08	161,710
10-3/4 x 13-1/2 Glulam Beam (9 LAMs)	2 x 40'	16 125	34	1290	2720	7 5146E08	1 5845E09	718,711
3 x 4 nom kickers to col	6 x 8'	1 0	2.3	48	110	2 7961E07	6 4078E07	29,066
8-3/4 x 9 Glulam Long columns (6 LAM)	2 x 36'	8 75	19 7	630	1418	3 6699E08	8 2603E08	374,681
6 x 6 Glulam Short columns (4 LAM)	2 x 17'	4.0	9.0	136	306	7.9224E07	1 7825E08	80,855
Subtotal Wood Support				4392	9539	2 5585E09	5 5568E09	2,520,508

3-30

900-800

Legend

BD FT = "Board Foot" (A Volume of Wood 1 Foot Long by 1 Foot Wide by 1 inch Thick)

EOX =  $10^x$ , an Exponent of 10.

Note

Material quantities are given for one 10 x 14 Km rectenna. The quantities are independent of the rectenna output power level.

### 3.3.4 Occupational Health Effects

The potential continuous exposure to low level microwave radiation is the most obvious potential health effect (Ref. 8). Figure 3-8 illustrates some factors affecting the rectenna flux density. If indeed the only serious, non-reversible problems related to human microwave exposure are thermal in nature, then protective microwave radiation shielded suits (Ref. 30) would probably not be required for most of the maintenance functions. The greatest concern for high intensity field would occur when working above a subarray that was unterminated or shorted. Under those conditions the combinations of incident and reflected fields would lead to standing waves of alternating low and high intensity with peak flux density of four times the incident power flux density. Thus, at the center of the array the additional proximity of large reflecting surfaces near a human operator could lead to additional standing wave enhancement that may yield dangerous flux densities. These infrequent conditions could be cause for hazards to personnel and thus should only be performed by properly shielded, microwave trained technicians.

Servicing the all-microwave collector for a captive load application will obviously require microwave protective gear and equipment. Temporary shields may have to be erected in that case.

If long term exposure to low level microwave radiation is determined to cause other physiological effects that are harmful, then all personnel in residence at the site would have to wear protective gear or employ a strategy of seeking screening shelter whenever their personal body carried alarm indicates a pre-set level of incident flux density.

Transient visits by other personnel or incidental exposure at low levels to infrequent workers may be tolerated. The shared land use personnel that stay mainly in shielded buildings or other equipment may not need protective gear.

However, those who are mainly outdoors or in certain agricultural pursuits beneath or among the rectennas or in the guard ring, if necessary, may require protective gear or vehicles.

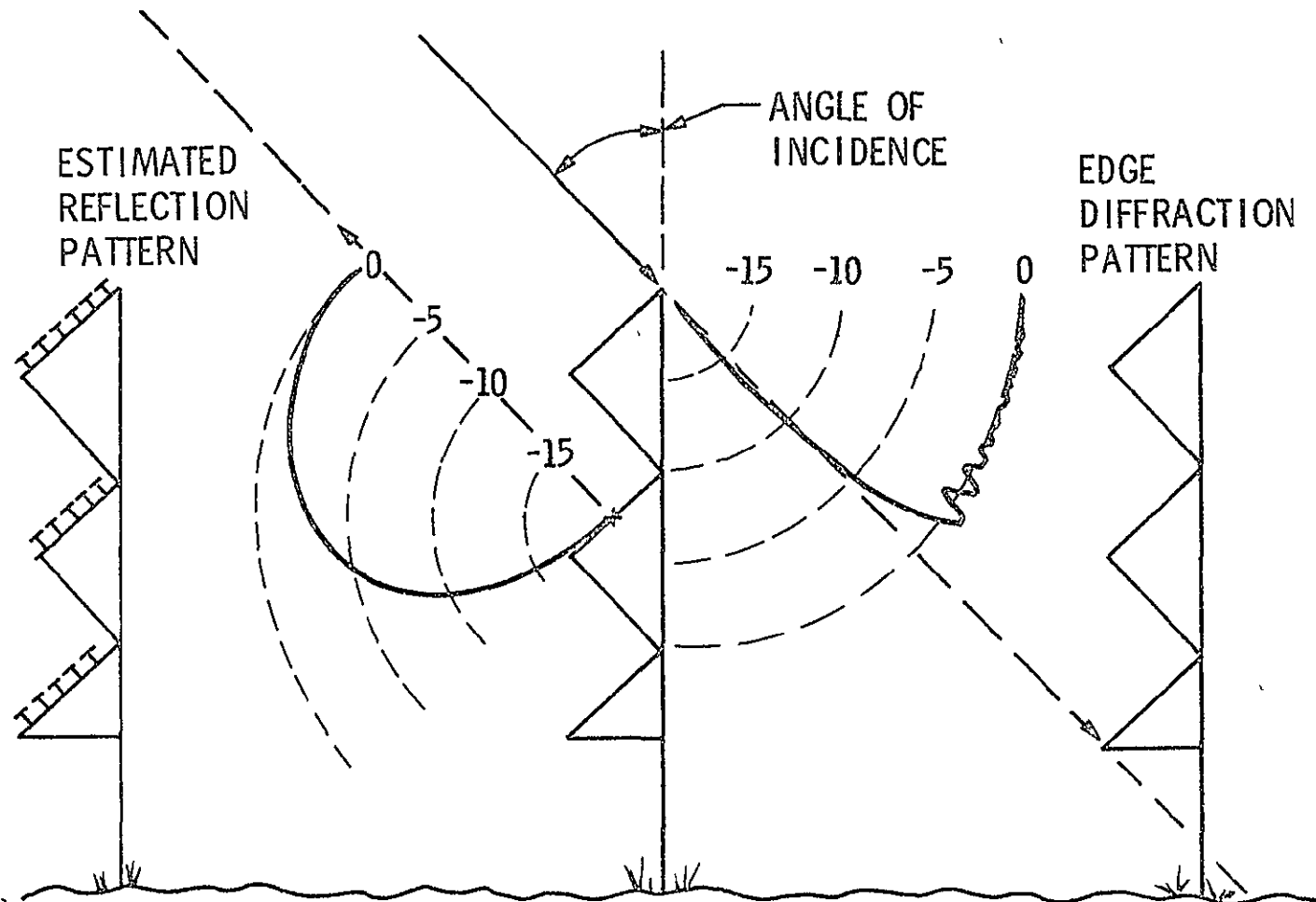

RECTENNA PATTERNS (dB, POLAR)

Fig. 3-8. Factors affecting the microwave flux density around the rectenna

Besides the microwave potential hazard, the high ac or dc voltage conditioning equipment represents potential lethal voltages to maintenance personnel required to repair or service that equipment.

The heights of the various equipments represent an occupational hazard relative to falls or tool droppage. Also, lightning strike potential is affected by the heights, conductors and array size.

The potential for wind driven projectiles is a remote hazard. Boredom brought about by the currently projected minimal maintenance activity associated with the mostly passive devices and static equipment, may be a potential hazard.

Perimeter or internal lighting is not felt to be necessary due to the low voltage and raised lower rectenna subarray edge location.

### 3.3.5 Construction

As currently envisioned, the construction phase of rectenna installation could involve the following scenario. First, select a construction base headquarters site which will later become the maintenance and operations workers housing and facility.

Grading of additional sites for the communication stations, major switch-gear and transformers would be next. After surveying and selecting the subarray pole lines, then any additional earthworks would be performed to allow service vehicle passage, promote proper drainage, or facilitate dual land use such as agricultural terracing, etc.

Any captive load industries known at the time would have their leases graded and utility connections made to the required edifices. Transformers would be emplaced.

While rectenna elements are being assembled into subarrays, the treated wooden supports would be drilled and fitted with hardware. The pilot beam transmitter facilities in the center of the array would be installed and connected to the standby service drop

As the pole diggers dig the holes and place poles, a "land train" would follow carrying poles, assembled subarrays and inverters which had been

previously marshalled at the construction headquarters. Current collection lines would be attached next and connected to the transformer busses as they are installed. The rectenna element testing technique of "sniffing" (Ref. 31) can be used to test the installed subarrays.

The carrier instrumentation would be connected and tested after the transformers are connected.

Meanwhile, the security fences would be installed and the remaining utility grid lines are brought into the site and connected to the protective disconnects and dispatch switch gear.

Agriculture or herding operations could commence as soon as the inverters are installed and connections made to the intermediate ac power collection points and tested.

The main impacts during rectenna construction are the creating and phaseout of the rectenna array support and assembly operations, the grading and facility construction operations and the visual aesthetics change. The transportation facilities for material reception will not be inconsequential - particularly for the quantities of element parts, poles and the large electrical apparatus. Rail lines may be desirable.

More than likely the rectenna would be scheduled to be completed and ready for operation before the SPS satellite is on station so that there is no delay in commencing power handling.

New labor categories are not envisioned at this time. The existing construction and electric utility trades and practices are adequate. The only different wrinkle is with regard to RF protective gear checkout and use.

Obviously there will be those in the rectenna community, township, county or parish who will welcome and those who will damn the land use change and the temporarily enhanced regional economy.

### 3.3.6 Security

Because of the diffuse nature of the microwave radiation and its collection scheme in the SPS, tight security will only be required around the concentrated energy portions of the facility. Both to protect life from high

voltage hazards or to prevent or frustrate terrorists acts or sabotage. The additional area requiring a degree of control would be the transmitter and its control functions associated with the pilot beams and interfaces with satellite commands or telemetry data. A degree of isolated redundancy in these areas as regards alternate transmitters, receivers, power and communications lines may be in order depending upon the state of society at the time of implementation.

Warning signs and/or fences for the guard ring perimeter if required are a possibility depending upon applicable regulations.

Warning lights on the EHV transmission towers may be required depending on the proximity to aircraft operations.

Obviously dual land and captive load operations may permit considerably more potential entry opportunities to areas requiring security. Guards, TV monitored surveillance, illumination and fences with vibration alarms may then be in order for sensitive areas.

Hence the terrorist threat potential is effective only so far as service disruption or material damage and thus the degree of security is appropriately lessened for rectennas as compared to nuclear sources of electric power.

### 3.3.7 Miscellaneous

As birds and squirrels can bend the rectenna elements of a subarray, it is recommended to minimize this potential impact that the antenna dipoles be placed in a vertical plane so as to present a minimum attractive perch

New symbiotic arrangements may be feasible because of the constant shade and elevated position of the rectenna.

Vines may be given opportunity to grow in abundance given the "grape-stake" format of the subarray support scheme.

Installing any structure in the desert out west away from constant habitation makes it a potential target for all manner of projectiles, particularly rifle launched. In a similar vein, hail can wreak havoc with the rectenna elements, creating employment for straightening and some replacement after an episode.



A large fenced rectenna array area will present an impediment to land migration.

An analysis will need be made of the effects of wind channeling by the E-W parallel rows of subarrays. Venturi effects could increase velocities, whereas flow disturbance may increase lift. The vortex shedding downstream at the edges may cause leaf stripping of screening vegetation, etc. Any humming from resonating the dipole elements may be a sound impact.

The corona crackle and hum along with the ozone odor when carried to the ground from the EHV lines may be an offensive impact in downdraughts

For certain mechanizations of the SPS it may be advantageous to perform load following over two rectennas that are in close proximity to time zone boundaries. If the transmitting spacecraft subarrays are small enough to encompass both rectenna arrays within the subarray beamwidth efficiently (as regards transmit array scan loss), then by the use of controlled level, coded simultaneous pilot beams from both sites in conjunction with a sympathetically designed pilot beam receiver scheme on the satellite, the power transmit array output can be made to split into two beams whose individual intensities can be set to split the total satellite power in any ratio - simply as a function of pilot beam ratios.

Another system flexibility has to do with supplying power to a single rectenna simultaneously from more than one spacecraft. If only two beams are used, they will interfere constructively and destructively so that the standing waves (or moving beat frequency pattern if different frequencies are used) yield over stressed and underutilized rectennas which would be inefficient. However, if for example three, four or more transmitters, all at different frequencies were used, then the "average" effective rectenna utilization could be high and stresses lower.

Visually, the basic rectenna array appears as a mottled surface of regular sharp outlined panels of aluminized color when viewed from the south. The mottled surface is due to the shadows cast by the dipoles. There are big shadow breaks when viewed from the east or west due to the stair stepped arrangement of the panels caused by breaking the surface into segments in order

to restrict the support heights and to accommodate tilting the panels relative to the earth's horizontal in order to be perpendicular to the beam coming from the satellite.

When viewed from the north, the rectenna appears as a grouping of spaced parallel lines running east-west. Depending upon the observers elevation, one can see the terrain between the subarrays if the "vertical" suspended subarray is used.

The ultimate visual impact is the result of several competing factors. The albedo balance array would have a "heat island" shimmer effect. The weather modification potential should be analyzed for the particular location.

Screening or RF absorbing trees to lessen the RFI effects will alter the visibility of the rectenna array.

#### 3.3.8 Deactivation

Deactivation of the rectenna site, if it should be desirable at some future time, is straightforward as there is no residual ionizing radiation. With the microwave beam off and the utility interconnection broken, the equipment is inert and contains no residual energy other than perhaps charged capacitors in the inverter inputs. These are readily discharged. Cooling fluids should be carefully drained from the large transformers and switches.

Attractive nuisance towers that may be climbed should probably be dismantled.

Thus the rectenna array unlike a nuclear facility presents no significant hazard to dismantling or deactivation. Long term isolated storage of components is not required.

### 3.4 CONCLUSIONS

The major impact of the rectenna facility of an SPS is the large land area required. In part this is a result of the low peak flux density which is also a safety measure.

The impact is mitigated to a degree by the fact that dual land use or shared occupancy is permissible. Captive or on-site electric or microwave power users are possible.

The major benefit is the very benign operational characteristics of the rectenna system. Other than the RFI production, the electric output comes unaccompanied by noise or great amounts of waste heat or atmospheric pollution (at least as far as the rectenna portion of the system is concerned )

The low level microwave flux density hazard questions are not yet satisfactorily resolved. If major effects are thermal in nature, then the consequences are almost nil. If not, then appropriate additional land area and fences will be required of the system.

The assembly of the rectennas may be capable of being socially engineered as a "cottage" industry and the assembly and to a lesser degree the fabrication, construction, maintenance and operations of the rectenna may provide a lift to the local economy in the area where the rectenna is built. Captive or integrated load industries could smooth this temporary economic impact upon phaseout of assembly.

The large use of wood as the primary structural material lessens the drain on non-renewable resources.

The low dc collection voltage may at first appear to be material intensive due to large conductor sizes required to accommodate the currents. However, the shielding, enclosures, and insulators required of a higher voltage system would require much more material.

The lack of inertia in the rectenna response time may be of value to utilities. The absence of any residual, or otherwise significant ionizing radiation is a plus for long term benefit considerations.

### 3.5 RECOMMENDATIONS

1. Long term biological experiments relative to low level microwave radiation effects should be undertaken.
2. Ionosphere effects on the pilot and power beams should be better defined through better analysis and experimentation.
3. Methods of efficiently directly producing ac output out of the rectennas should be investigated in order to eliminate the inverters.
4. Harmonic radiated and fundamental direct and cross-polarized rescattered radiation distribution pattern of elements and sub-arrays should be calculated and measured
5. Weatherizing of the rectenna elements should be tested and further refined. Dust and moisture tolerance levels and margins should be determined
6. The SPS depolarization accommodation scheme should be developed and optimized
7. The constant voltage output-selectable variable flux density input rectenna element design should be accomplished to allow optimizing the cottage assembly industries.
8. The rectenna subsystem transient analysis should be performed to allow proper characteristic impedance design and optimum over-voltage protective scheme development.

9. The ground plane design configuration for optimum insolation with maximum conversion-collection efficiency and RF shielding effectiveness should be researched and developed.
10. Minimum conductor designs for the opaque rectenna version should be developed along with the color blending for visual aesthetics.
11. Repair, cleaning and other maintenance techniques and equipment should be developed.
12. Bird, animal and insect nesting studies should be performed along with vegetation intrusion effects investigations
13. Subarray edge diffraction effects studies should be performed to determine optimum edge shielding and minimum interference edge conditions.
14. The stair step design details should be investigated to determine the optimum "tread" width and "rise" vs. latitude.
15. The optimum partitioning of the array should be investigated to promote maximum effectiveness in the utility intertie.
16. Minimum material backup support structures for the transparent or opaque ground planes along with wood support techniques should be developed to fit various climactic environments and soil types.
17. Optimum pilot beam transmitter redundancy and location geometry should be researched
18. Techniques for growing and treating long wooden poles need to be further developed to yield the abundance required for subarray support poles
19. The land train for installation of subarrays needs to be further detailed relative to traction and motive scheme, power supply and subarray and pole resupply material handling schemes

20. Albedo modification and control schemes need to be analyzed, modeled and surface treatments investigated.
21. Additional dual uses of the ordered conducting subarrays such as in a low frequency radio telescope array need to be investigated
22. Quantitative calculations of RFI flux density and spectral distribution along with receiver susceptibility need to be performed.
23. Weather and wind modification effects need to be analyzed
24. The interarray voltage transformation optimum levels need to be developed
25. Dual land use and shared occupancy candidates need further investigation.
26. The losses associated with constructing the rectenna array in a flat, un-tilted format should be assessed to compare against the broken, perpendicular surface approach.

## SECTION IV

## REFERENCES

1. JSC 11568, NASA Lyndon B. Johnson Space Center, "Initial Technical, Environmental and Economic Evaluation of Space Solar Power Concepts" Vol. I and II, August 31, 1976.
2. IEEE Trans. Antenna Propagation (Special issue on Active and Adaptive Antennas), Vol AP-12, No. 5, pp. 140-233, Mar. 1964.
3. Bathker, D. A., et al., Single- and Dual-Carrier Microwave Noise Abatement in the Deep Space Network, TM-33-733, Jet Propulsion Lab., Pasadena, Ca. Aug. 1, 1975.
4. NASA CR-134886, ER75-4368 "Microwave Power Transmission System Studies", 4-volumes, NASA Lewis Research Center, Dec. 1975.
5. Report 391-2, "Radiation Diagrams of Antennae for Earth Stations in the Fixed Satellite Service for Use in Interference Studies", Thirteenth Plenary Assembly, International Radio Consultative Committee, Vol. 4, pp. 176-180, Geneva, 1974.
6. J. L. Allen, "Array Antennas: New Applications for an Old Technique", IEEE Spectrum, p. 125, November 1964.
7. A. D. MacDonald, "High-Frequency Breakdown in Air at High Altitudes", Proceedings of the IRE, pp. 436-441, Vol. 47, March 1959.
8. Tyler, P.E., Ed. "Biologic Effects of Nonionizing Radiation," Annals of the New York Academy of Sciences, Vol. 247, Feb 28, 1975.
9. Maynard, O. E., et al., Microwave Power Transmission Systems Studies, Vol. II, NASA CR-134886, December 1975.
10. Raytheon Co., Space Based Solar Power Conversion and Delivery Systems Study, Vol. III - Microwave Power Transmission Studies, ECON-NASA MSFC Contract # NAS8-31308.
11. Utlaut, W. F., "An Ionospheric Modification Experiment using Very High Power, High-frequency Transmission," J. Geophys. Research, 75 (1970).
12. Radio Science, 9, 881-1090 (1974).
13. Lawrence, R. S., et al., "A Survey of Ionospheric Effects upon Earth-Space Radio Propagation," Proc. IEEE, 52, January 1964.

14. Holway, L. H., Jr., and Meltz, G., "Heating of the Lower Ionosphere of Powerful Radio Waves," J. Geophysical Research, 78, 8402-8408, 1973
15. Perkins, F. W., personal communication, April 1977
16. Report 574, "Ionospheric Cross-Modulation," CCIR Study Group 6, CCIR XIII Plenary Assembly, Geneva, 1974.
17. W. E. Gordon, "Ionosphere/Microwave Beam Interaction Study," Rice University, Contract NAS9-15212 for NASA JSC, in progress.
18. Brown, W. C , "Optimization of the Efficiency and Other Properties of the Rectenna Element," 1976 IEEE-MTT-S Int Micro. Sym. Digest, pp 142-144
19. Glaser, P E., "Power from the Sun. Its Future," Science, Vol. 162, pp. 857-861, Nov 22, 1968.
20. Dickinson, R., and Brown, W., "Radiated Microwave Power Transmission System Efficiency Measurements," TM 33-727, Jet Propulsion Lab , Pasadena, Calif , May 15, 1975
21. Dickinson, R., "Performance of a High Power, 2 383-GHz Receiving Array in Wireless Power Transmission Over 1.54 km," 1976 IEEE-MTT-S Int. Micro Sym Digest, pp. 139-141.
22. Dickinson, R., "Evaluation of a Microwave High-Power Reception-Conversion Array for Wireless Power Transmission," TM 33-741, Jet Propulsion Lab , Pasadena, Calif., Sept. 1, 1975, p 9.
23. J. Microwave Power, 10 (4), 1975, p. 336.
24. Ching, B., "Space Power Systems - What Environmental Impact?" Astronautics and Aeronautics, Feb. 1977, pp. 60-65.
25. Liao, S , "RF Shielding Effectiveness and Light Transmission of Copper or Silver Film Coating on Plastic Substrate," IEEE Trans. on Electromagnetic Compatibility, Vol EMC-18, No. 4, Nov. 1976, pp. 148-153.
26. Electric World, 100th Anniversary Issue, June 1, 1974, p. 158.
27. Thompson, C., "Wood Substation Design Beats Out Steel," Electrical World, p. 95-97, Sept. 15, 1976.
28. Singh, P., and Chen, C., "Capital Cost Estimation on 765 KV Substations," AACE Bulletin, pp. 201-205, Vol. 17, No. 6, Dec. 1975.
29. Okress, E., Microwave Power Engineering, Vol. 2, Applications, Academic Press, N.Y., 1968.



30. Klascius, A., "Microwave Radiation Protective Suit," American Industrial Hygiene Asso. Journal, Vol. 32, No 11, pp. 771-774, Nov. 1971.
31. Raytheon Final Report, "Reception-Conversion Subsystem (RXCV) for Microwave Power Transmission System," JPL Contract 953968, pp. 3-8, 3-11, Sept 1, 1975

Added References

- A. ITU, Article 7, Section VIII, Radio Regulations, Geneva, 1976.
- B. CCIR, Report 387-2, Volume IX, XIIIth Plenary Assembly, p. 379, ITU, Geneva, 1975.
- C. CCIR, Report 209-3, Volume IX, XIIIth Plenary Assembly, p. 370, ITU, Geneva, 1975.
- D. ITU, Article 3, Paragraph 116A, Radio Regulations, Geneva, 1976.
- E. CCIR, Report 224-3, Volume II, XIIIth Plenary Assembly, pp. 282-283, ITU, Geneva, 1975.
- F. CCIR, Recommendation 365-2, Volume II, XIIIth Plenary Assembly, p. 19, ITU, Geneva, 1975.