

N79-16775**VOYAGER INVESTIGATIONS OF
THE SATURNIAN SYSTEM****E. C. Stone****California Institute of Technology
Pasadena, California 91125***ABSTRACT**

This paper provides a brief review of the objectives and capabilities of the Voyager Mission at Saturn. In addition to a brief description of the eleven Voyager Investigations and the Saturn encounter geometry, the scientific capabilities are discussed in the areas of Atmospheric, Satellite, Magnetospheric, and Ring studies.

INTRODUCTION

In 1977 two Voyager spacecraft were launched toward encounters with Jupiter, Saturn, and possibly Uranus. In this paper the eleven scientific investigations and the encounter geometry at Saturn will first be briefly reviewed, followed by a discussion of the planned studies of the Saturnian system. This discussion, which will be organized into the four broad categories of Atmospheres, Satellites, Magnetosphere, and Rings, will necessarily be preliminary, since design of the sequence of observations will not begin until 1979. More detailed information on the mission and each of the eleven investigations is available in two special issues of *Space Science Reviews* (Stone, 1977).

*Voyager Project Scientist

INVESTIGATIONS

The eleven investigations and the corresponding Principal Investigators and Team Leaders are listed in Table 1. Although not shown, a total of ~100 scientific investigators from 38 institutions are involved in the Voyager mission. A brief summary of the nominal characteristics of the instruments is contained in Table 2, while Figure 1 illustrates their location on the Voyager spacecraft. The four boresighted remote sensing instruments (ISS, IRIS, PPS, and UVS) share the scan platform which has two axes of articulation for nearly complete angular coverage.

ENCOUNTER CHARACTERISTICS

The heliocentric trajectories of the Voyager spacecraft are illustrated in Figure 2, and details of the Saturn encounters are summarized in Table 3.

Table 1. Voyager Science Investigations

Investigation Area	Principal Investigator/Institution
Imaging Science (ISS)	Smith/Univ. Arizona (Team Leader)
Infrared Spectroscopy and Radiometry (IRIS)	Hanel/GSFC
Photopolarimetry (PPS)	Lillie/Univ. Colorado
Ultraviolet Spectroscopy (UVS)	Broadfoot/KPNO
Radio Science (RSS)	Eshleman/Stanford Univ. (Team Leader)
Magnetic Fields (MAG)	Ness/GSFC
Plasma (PIS)	Bridge/MIT
Plasma Wave (PWS)	Scarf/TRW
Planetary Radio Astronomy (PRA)	Warwick/Univ. Colorado
Low Energy Charged Particles (LECP)	Krimigis/JHU/APL
Cosmic Rays (CRS)	Vogt/Caltech

Table 2. Instrument Characteristics

Investigation	Nominal Characteristics
ISS	Two Se-S vidicon cameras ($f = 1500$ mm and $f = 200$ mm); Narrow angle camera: $19 \mu\text{rad}/\text{line pair}$, 2900 - 6400 Å
IRIS	Michelson interferometer (3.3 - 50 μm) and radiometer (0.33 - 2 μm); 51 cm telescope; 0.25° FOV
PPS	Photomultiplier with 15 cm telescope; 2350 - 7500 Å; 3.5° , 1° , $1/4^\circ$, $1/16^\circ$, FOV; 3 linear polarizers
UVS	Grating spectrometer; 500 - 1700 Å with 10 Å resolution; airglow ($1^\circ \times 0.1^\circ$ FOV) and occultation ($1^\circ \times 0.5^\circ$ FOV)
RSS	S-Band (2.3 GHz) and X-band (8.4 GHz); Ultra Stable Oscillator ($<4 \times 10^{-12}$ short term drift)
MAG	Two low field ($<10^{-6}$ - 0.5 G) and two high field (5×10^{-4} - 20 G) magnetometers; 13 m boom; 0 - 16.7 Hz
PLS	Earth-pointing sensor (10 eV - 6 keV ions) and lateral sensor (10 eV - 6 keV ions, 4 eV - 6 keV electrons)
PWS	Sixteen channels (10 Hz - 56.2 kHz); waveform analyzer (150 Hz - 10 kHz); share PRA antennas
PRA	Stepping receiver (1.2 kHz and 20.4 kHz - 40.5 MHz); right and left circular polarization; orthogonal 10 m monopole antennas
LECP	Two solid state detector systems on rotating platform; 10 keV - 10 MeV electrons; 10 keV/nuc - 150 MeV/nuc ions
CRS	Multiple solid state detector telescopes; 3 - 110 MeV electrons; ~ 1 - 500 MeV/nuc nuclei; 3-dimensional anisotropies

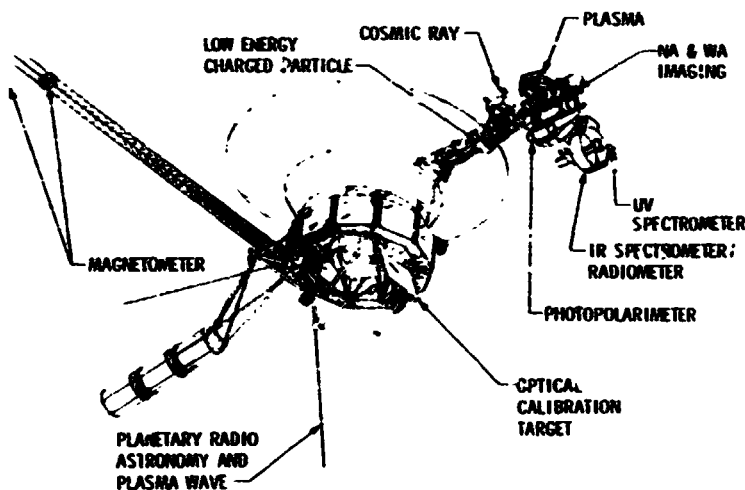

Figure 1. A drawing of the Voyager spacecraft showing the location of the science instruments. The Radio Science Investigation uses the dual-frequency spacecraft transmitters, an Ultra Stable Oscillator, and the 12' parabolic antenna.

The trajectory of the first-arriving spacecraft at Saturn is labeled JST (Jupiter-Saturn-Titan) because the trajectory includes a close encounter with Titan. Since the second arriving spacecraft can be targeted to either the Uranus aim point at Saturn or to a close Titan flyby, the trajectory is referred to as JSX. Figure 2 illustrates both the Uranus option (X=U) and the Titan option (X=TB).

The targeting of JSX will affect the nature of the investigations possible at Saturn. As shown in Table 3, for example, the JSX(X=U) trajectory does not have an

Table 3. Saturn Encounters

		JST	JSX(X=U)	JSX(X=T)
Date, Closest Approach		11/12/80	8/26/81	8/27/81
Radius, Closest Approach		3.0 R _S	2.7 R _S	3.4 R _S
Radius, Ring Plane Crossing		19.6 R _S 6.2 R _S	2.9 R _S	19.6 R _S 5.7 R _S
Distance (10 ³ km), Earth Occultation	{ Saturn	230	156	218
	{ Rings	~250	-	~200
	{ Titan	29	-	23
Distance (10 ³ km), Sun Occultation	{ Saturn	235	158	219
	{ Rings (A, B)	~300	-	~190
	{ Titan	24	-	25

occultation of the sun and Earth by either the Rings or Titan. Thus, the Uranus option will be selected only if JST accomplishes the major scientific objectives at Saturn, Titan, and the Rings, and only if the Voyager 2 spacecraft appears healthy enough to be sent on an additional 4-year mission to Uranus. The geometries of the JST and JSX(X=U) flybys is illustrated in Figures 3 and 4.

ATMOSPHERIC STUDIES

There are several interrelated aspects of the Saturnian and Titanian atmospheres which will be studied by Voyager, including dynamics, structure, and composition. Some of the general characteristics of these studies will be discussed below, with subsequent papers by B. A. Smith, R. A. Hanel, and G. L. Tyler providing more specific details for the Imaging, Infrared, and Radio Science investigations.

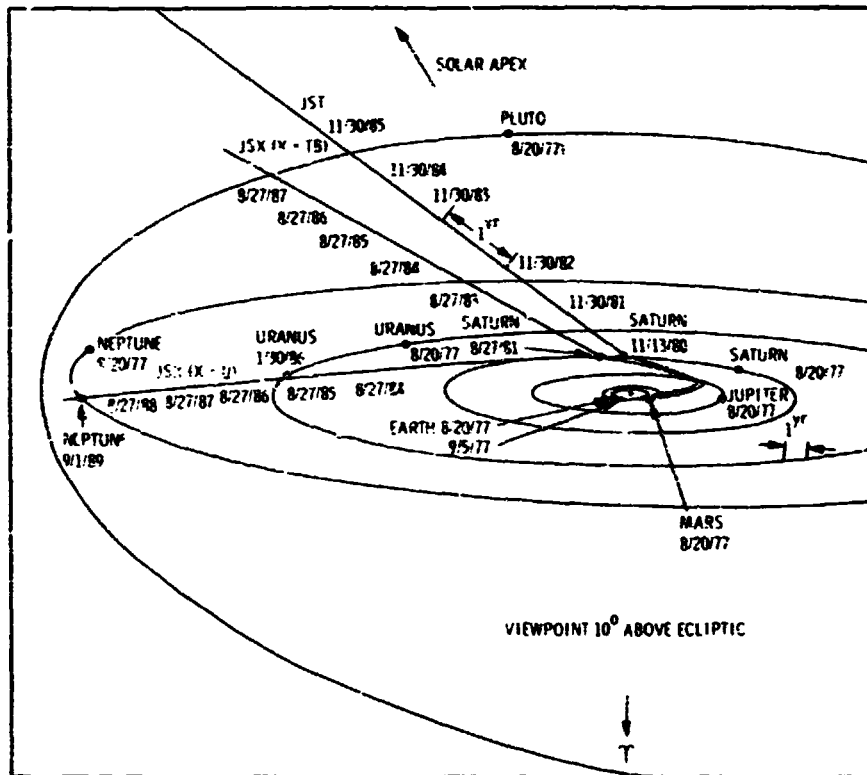
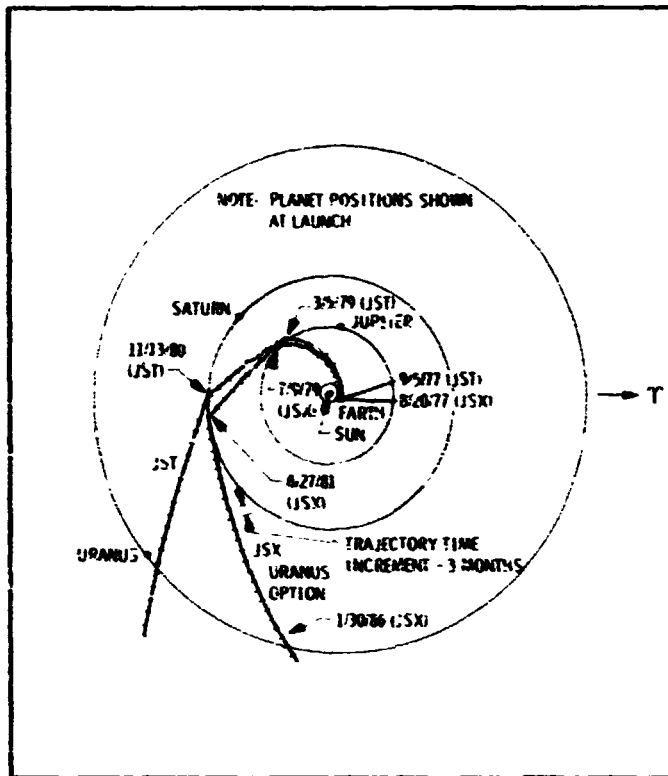

Figure 2. Heliocentric views of the Voyager trajectories.

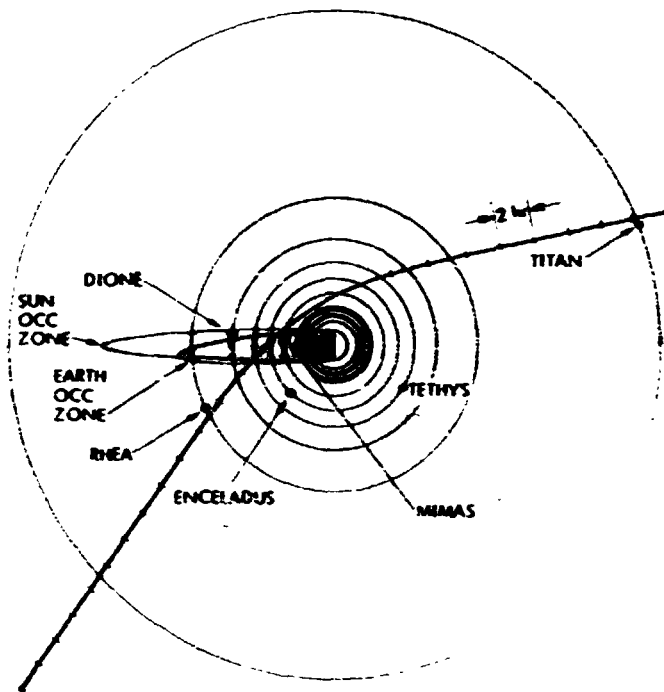

Figure 3. A view normal to the Saturnian equatorial plane of the JST encounter on November 12, 1980. The satellite positions are shown at satellite closest approach.

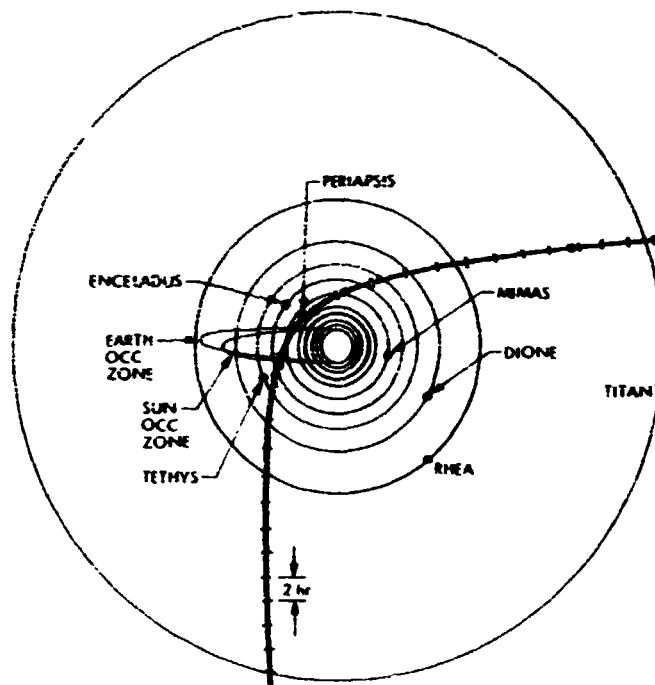

Figure 4. A view normal to the Saturnian equatorial plane of the JSX(X=U) encounter on August 27, 1981. The satellite positions are shown at satellite closest approach.

Since the study of atmospheric dynamics requires observations over an extended period of time, one of the key factors is the observing time available at a specified spatial resolution. Figure 5 illustrates the observing time as a function of resolution at Saturn for the narrow angle (NA) camera and the $1/4^\circ$ field-of-view (FOV) of IRIS and PPS. Since even a very good resolution of $1''$ from the ground corresponds to ~ 7000 km at Saturn, the Imaging System will have significantly better resolution than ground-based telescopes throughout the 80 days (~ 2000 hr) prior to encounter, and there will be 30 hours during which IRIS and PPS will have resolution better than ~ 7000 km.

Latitude coverage is also important to a study of the atmosphere on a global scale. In fact, in a previous paper Tokunaga reported evidence that the temperature inversion is hotter in the South polar region than at the equator. As shown in Figure 6, the spacecraft latitude of the two Voyager flybys ranges from approximately -40° to $+30^\circ$, providing useful coverage of higher latitudes in both hemispheres.

Studies of atmospheric structure require detailed observations of the pressure-temperature profile. The expected capability of the Voyager investigations is shown in Figure 7 which has been adapted from the Voyager Atmospheres Working Group Report. The figure indicates both the pressure range over which a given technique is expected to be useful and the expected scale height resolution of the measurement. The RSS measurement employs the dual-frequency radio occultation, while the IRIS measurement uses the pressure-broadened H_2 band at 250 to 500 cm^{-1} and the CH_4 band at 1306 cm^{-1} as temperature sounders. The UVS measurement in the upper atmosphere is a solar occultation measurement which should provide an altitude profile for H_2 , CH_4 , C_2H_6 , and C_2H_2 absorption. Stellar occultations and terminator scans with PPS will also contribute to the determination of the pressure-temperature profile.

The same techniques will be applied in the study of Titan's atmosphere. Both R. A. Hanel and G. L. Tyler will report in subsequent papers on recent analyses of the expected capability at Titan.

SATELLITE STUDIES

A characterization of the surfaces of the satellites will be accomplished with a combination of high-resolution imaging, infrared spectral studies, and polarimetric

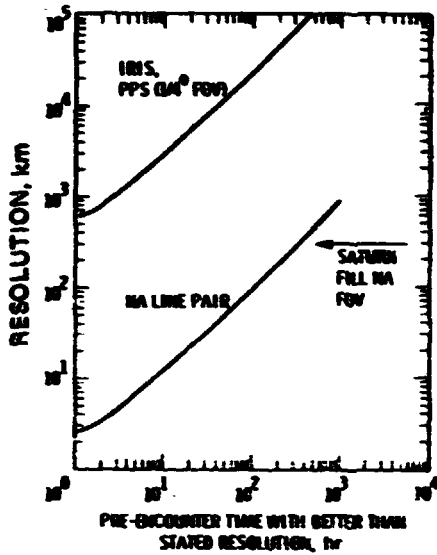

Figure 5. The length of time during which spatial resolution of Saturn's atmosphere exceeds a given value.

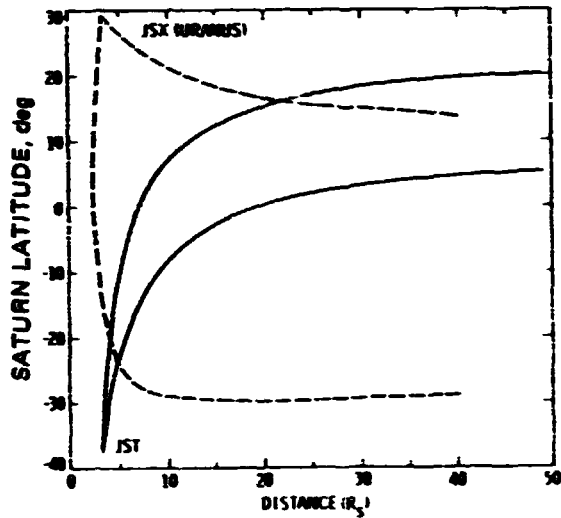

Figure 6. The subcraft latitude for the Voyager trajectories as a function of radial distance. For reference, note that $1R_S = 60000$ km.

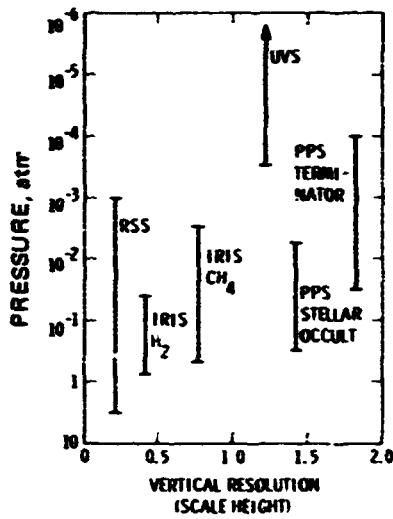

Figure 7. The vertical resolution and pressure range over which various techniques will yield information on the temperature-pressure profile in Saturn's atmosphere. This figure is adapted from the Voyager Atmospheres Working Group Report.

studies over a wide range of phase angles. The closest approach distances to the various satellites are indicated in Table 4 for all three possible trajectories.

Imaging resolution of the satellites SI through SVI will be significantly better than the 5 km/line pair resolution which is characteristic of the well-known mosaics of the half-lit disk of Mercury obtained by Mariner 10.

The densities of the satellites is also an important characteristic which will be studied by combining mass determinations from precise radio-navigation techniques with size determinations from the Imaging System. Figure 8, which is adapted from Fehleman *et al.* (1977), illustrates the expected capability. The uncertainty in the mass estimates is indicated by the labels on the diagonal solid lines, while the uncertainty in the volume estimates are indicated by the dashed lines. For this estimate, it has been assumed that the best estimate of the volume is uncertain to 0.4%, corresponding to a 1 pixel uncertainty in the diameter of a satellite image which fills the narrow-angle camera field-of-view. Thus, the mass of Titan (S6) will be determined to $\leq 0.02\%$, but

Table 4. Satellite Encounters

	Satellite	Closest Approach* (10^3 km)		
		JST	JSX(X=U)	JSX(X=TB)
SI	Mimas	89	315	116
SII	Enceladus	200	86	102
SIII	Tethys	416	92	150
SIV	Dione	163	503	91
SV	Rhea	74	648	199
SVI	Titan	7	667	15
SVII	Hyperion	884	480	869
SVIII	Iapetus	2400	918	1000
SIX	Phoebe *	13500		7500

*Narrow angle camera resolution is 2 km/line pair at 100000 km.

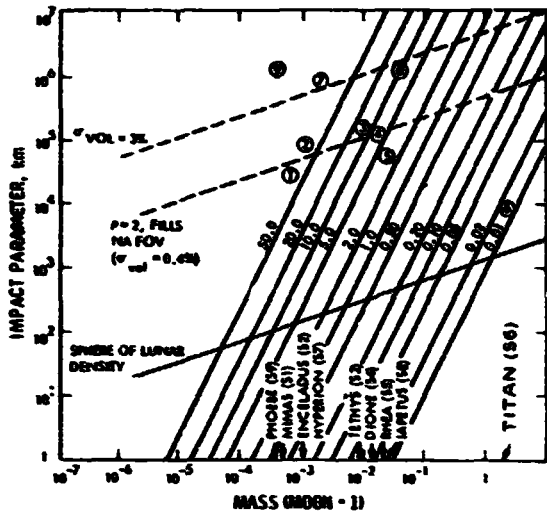

Figure 8. The percent error in mass and volume as a function of flyby distance and satellite mass. The diagonal solid lines are labeled with the mass uncertainties for a flyby velocity of 20 km/sec, while the dashed lines indicate the volume uncertainty corresponding to 1 pixel in the narrow angle camera. Adapted from Esbleman et al., (1977).

the density will be uncertain to $\sim 0.4\%$. For all other satellites, the density uncertainty will be dominated by the mass uncertainty which ranges from $\sim 3\%$ to $\sim 15\%$ for Rhea (S5), Dione (S4), Iapetus (S3), and Tethys (S3), and is $>50\%$ for all the others.

The interaction of the satellites with the magnetosphere is also an important objective which will be best studied during the close Titan flyby (7000 km) illustrated in Figure 9. The close flyby not only improves the detectability of any magnetic field at Titan, but also maximizes the probability that the spacecraft will intercept any magnetospheric wake, whether due to the corotation of the magnetosphere or due to a radial outstreaming (planetary wind).

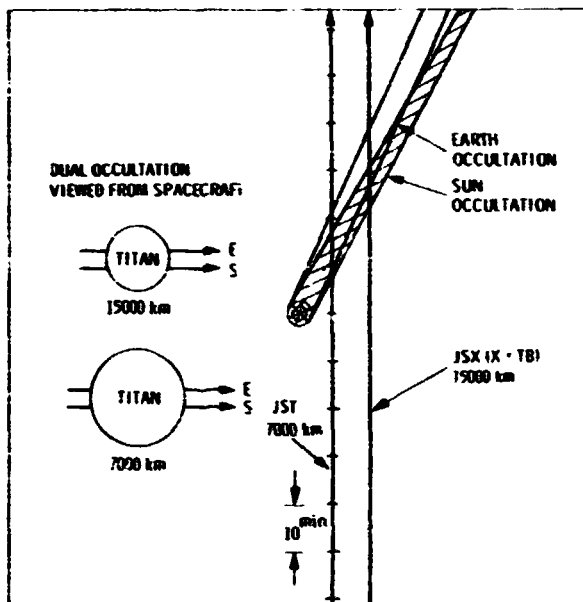

Figure 9. A view normal to Titan's orbital plane of the Voyager encounter. The JST encounter will be at 7000 km, while the JSX (X=TB) is nominally at 15000 km.

ORIGINAL PAGE #
OF POOR QUALITY

MAGNETOSPHERIC STUDIES

In addition to studying the interaction at Titan, Voyager will perform detailed measurements of the Saturnian magnetosphere, the evidence for which has been discussed by J. W. Warwick in a preceding paper. The spatial coverage of a possible magnetosphere is illustrated in Figure 10 which has been adapted from Scarf and Gurnett (1977). As indicated in the figure, the local times of the exit legs of JST and JSX(X=U) are quite different. Although not indicated, the latitudes of the exit legs are also quite different, with JST exiting at approximately $+20^\circ$ and JSX(X=U) at -30° (see Figure 6). Thus, JST and JSX(X=U) provide important complementary coverage of the magnetosphere.

The Voyager investigations provide broad coverage of the particle and wave phenomena expected at Saturn. Figures 11 and 12 from the Voyager Magnetospheres Working Group Report summarize the coverage. Note that the PRA frequency range includes the 300 kHz to 1 MHz interval in which Saturn signals have been detected by Brown (1975) and the PWS range includes the electron and ion plasma and cyclotron frequencies expected at Saturn (Scarf and Gurnett, 1977).

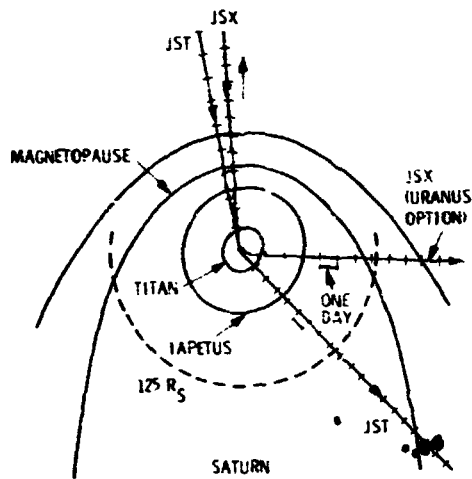

Figure 10. A view normal to Saturn's equatorial plane of the Voyager trajectories through a possible magnetosphere. Adapted from Scarf and Gurnett (1977).

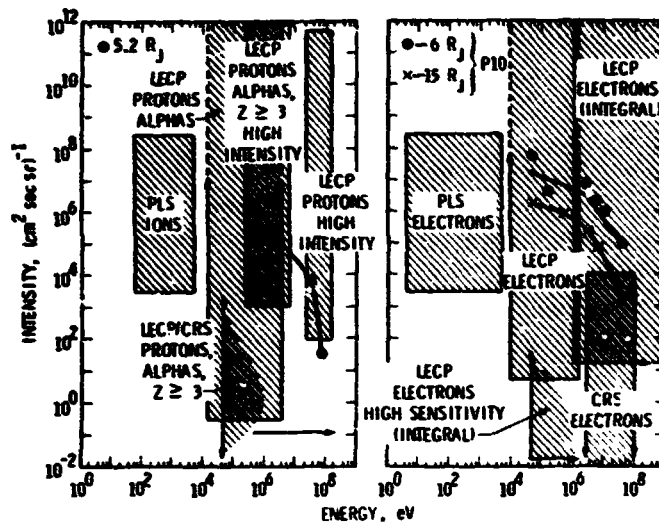

Figure 11. The intensity and energy coverage of electrons and ions by the Voyager instruments. The data points indicate the intensities observed by Pioneer 10 at Jupiter. This figure is from the Voyager Magnetospheres Working Group Report.

ORIGINAL PAGE IS
OF POOR QUALITY

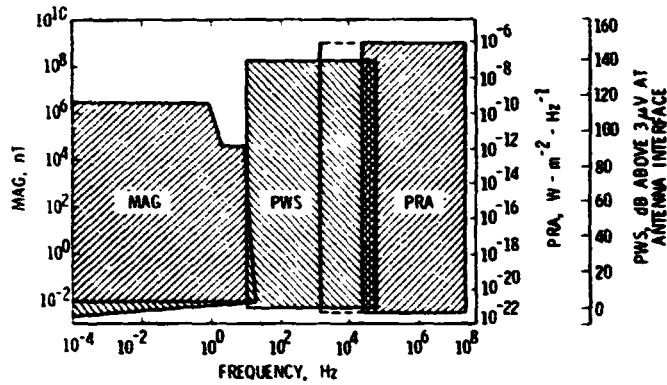

Figure 12. The frequency and intensity coverage of waves by the Voyager instruments. Adapted from the Voyager Magnetospheres Working Group Report.

RING STUDIES

The study of Saturn's Rings is also a primary Voyager objective which will be studied by several of the investigations. The Radio Science Team will use the attenuation and scattering of the dual-frequency radio to study particle size distribution and total amount of material in the ring as a function of radial distance from the planet. The JST trajectory was chosen so that the flyby geometry optimizes the high radial resolution which is possible with Doppler techniques as will be described by G. L. Tyler in a subsequent paper. Figure 13 illustrates the flybys as seen from Earth. Note that a radio occultation of the Rings occurs only on the outbound leg of JST.

Although the JSX(X=U) trajectory does not provide a ring occultation, it does provide a good viewing geometry for the scan platform instruments. IRIS will be used to study the eclipse cooling of the ring particles and to look for long wavelength cutoffs in the emitted radiation, while the PPS will view scattered light from the Rings at various phase angles and will observe stellar occultations by the Rings. Of course, the Imaging System will directly view the Rings to search for large objects (≥ 1 km) and to search for structure which may be related to Ring dynamics.

The estimated volume density sensitivity of the various observations is illustrated in Figure 14 which has been adapted from the Voyager Saturn's Rings Working Group Report. Assuming the upper limit to the E-Ring optical depth discussed by B. A. Smith in a preceding paper, the E-Ring will be ~ 3 orders of magnitude below the PPS sensitivity if it is composed of mm-sized particles, but may just be detectable in the less likely event that the particles are micron-sized.

CONCLUSION

This is necessarily a rather brief overview of the Voyager capabilities for the study of the Saturnian system. Detailed planning of the observational strategies will begin a year from now, so that experience with the JST encounter at Jupiter can be folded into the plans for the Saturn encounter. In addition, results from the Pioneer 11 encounter with Saturn in September 1979 may significantly affect the Voyager observational strategy. Thus, the detailed scientific objectives of the Voyager Mission will continue to evolve within the general capability described in this paper.

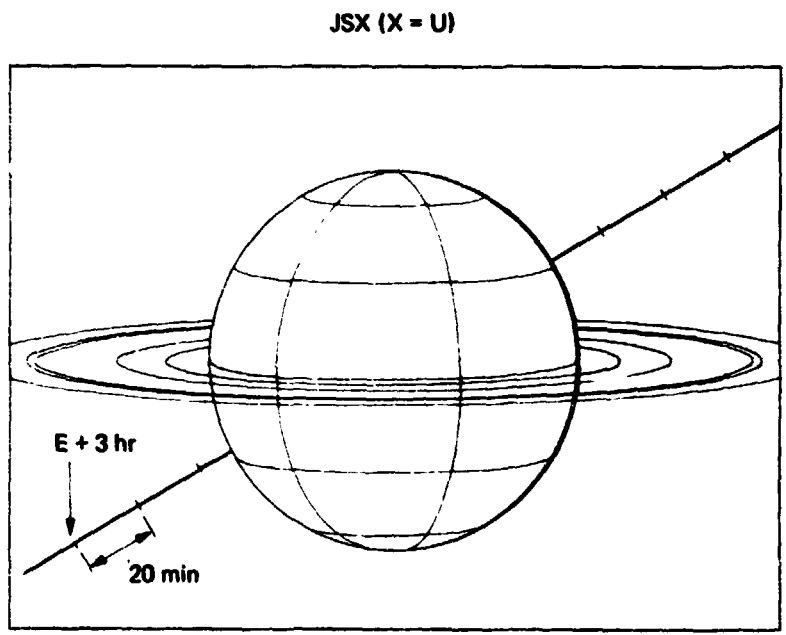
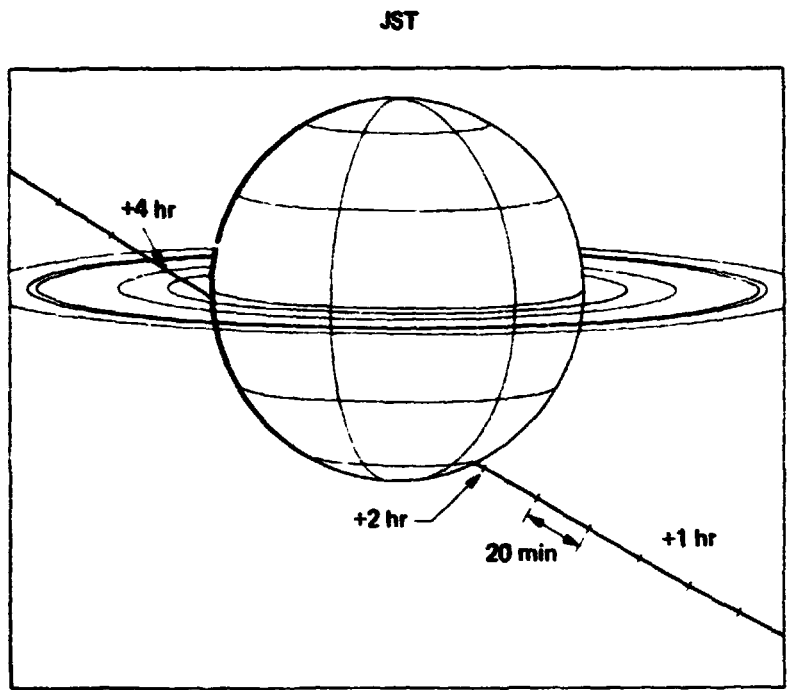

Figure 13. Earthviews of the Voyager encounter at Saturn

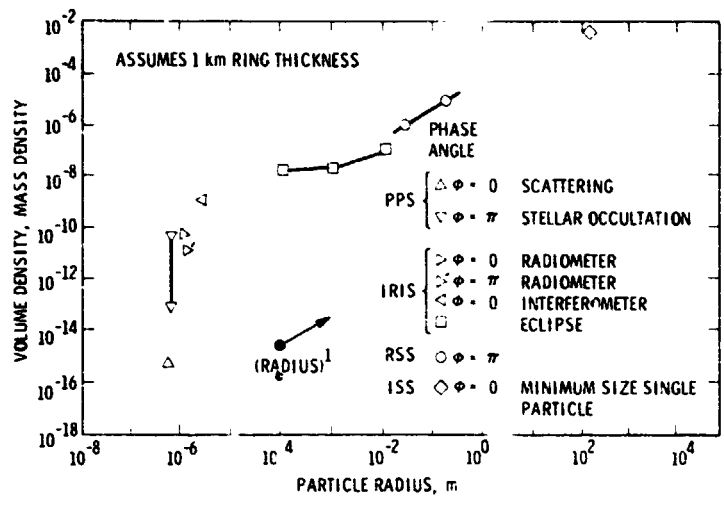

Figure 14. The estimated minimum detectable volume densities as a function of particle radius for various measurements of Saturn's Rings. The phase angles of the different observations are indicated. Note that the minimum detectable volume density scales linearly with the particle radius and inversely with ring thickness.

ORIGINAL PAGE IS
OF POOR QUALITY

ACKNOWLEDGEMENTS

The Voyager Project is being carried out for the National Aeronautics and Space Administration by the Jet Propulsion Laboratory of the California Institute of Technology under contract NAS 7-100.

REFERENCES

Brown, L. W. (1975). Saturn radio emission near 1 MHz. *Astrophys. J.* 198, L89-L92.
 Eshleman, V. R., Tyler, G. L., Anderson, J. D., Fieldbo, G., Levy, G. S., Wood, G. E., and Croft, T. A. (1977). Radio science investigations with Voyager. *Space Sci. Rev.* 21, 207-232.
 Kohlase, C. E., and Penzo, P. A. (1977). Voyager mission description. *Space Sci. Rev.* 21, 77-102.
 Scarf, F. L., and Gurnett, D. A. (1977). A plasma wave investigation for the Voyager Mission. *Space Sci. Rev.* 21, 289-308.
 Stone, E. C., ed. (1977). The Voyager Project. *Space Sci. Rev.* 21, 75-376.