

NASA
CR
2982
c.1

NASA Contractor Report 2982

TECH LIBRARY KAFB, NM

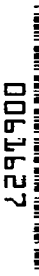

LOAN COPY: RETURN TO
AFWL TECHNICAL LIBRARY
KIRTLAND AFB, N.M.

Development of Integrated Programs for Aerospace-Vehicle Design (IPAD) - Product Manufacture Interactions With the Design Process

Harold A. Crowell

CONTRACT NAS1-14700
MARCH 1979

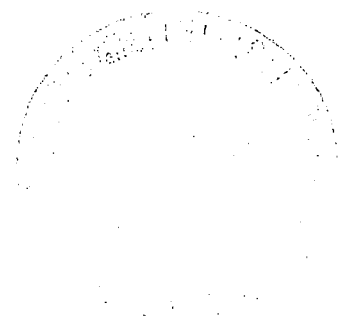



NASA Contractor Report 2982

Development of Integrated Programs
for Aerospace-Vehicle Design (IPAD) -
Product Manufacture Interactions
With the Design Process

Harold A. Crowell
Boeing Commercial Airplane Company
Seattle, Washington

Prepared for
Langley Research Center
under Contract NAS1-14700

NASA

National Aeronautics
and Space Administration

**Scientific and Technical
Information Office**

1979

FOREWORD

The document was developed as part of the Integrated Programs for Aerospace-Vehicle Design (IPAD) program documentation in accordance with contract NAS1-14700. Other closely related IPAD documents are:

- NASA CK 2981 Reference Design Process (D6-IPAD-70010-D)
- NASA CR 2983 Produce Program Management Systems (D6-IPAD-70035-D)
- NASA CR 2984 Integrated Information Processing Requirements (D6-IPAD-70012-D)
- NASA CR 2985 IPAD User Requirements (D6-IPAD-70013-D)

Special acknowledgement is made of the assistance provided by the following contributors to this document:

These Boeing engineers contributed directly to the development of the document: G. Anderson, M. Davies, J. Kelleher, S. Robertson, and E. Mangan.

The following Boeing managers and engineers contributed their comments and recommendations: A. Berryman, W. Diefenderfer, H. Enns, E. Hisey, M. Monro, D. Nichols, H. Smith, W. Spencer, J. Stokes, R. Thompson, R. Trousil, and R. Wallace.

The NASA Langley Research Center Document Coordinator for this document was Jaroslaw Sobieszczanski.

In addition, assistance in the form of comments and recommendations was received from the Industry Technical Assistance Board (ITAB); Air Force Materials Laboratory, WPAFB; and the NASA IPAD Project Office, Langley Research Center.

Measurements included in this document were not generated on the IPAD program; therefore, they are shown here in U. S. customary units. A conversion table (U.S. to SI) is included in appendix E.

CONTENTS

	<u>Page</u>
1.0 SUMMARY	1
2.0 INTRODUCTION	2
2.1 SCOPE	2
2.2 OBJECTIVE	2
2.3 PURPOSE	6
2.4 APPROACH	6
2.5 USE OF THIS DOCUMENT	7
3.0 ABBREVIATIONS	9
4.0 THE MANUFACTURING PROCESS	11
4.1 MANUFACTURING EVENTS/CONCEPTUAL DESIGN PHASE	12
4.1.1 Facility Requirements Analysis	14
4.1.2 Fabrication Resource Estimates	14
4.1.3 Material and Process Development	14
4.1.4 CAD/CAM Developments	15
4.1.5 Major Tooling Analysis	15
4.1.6 Quality Assurance Technology	15
4.1.7 Cost Studies	15
4.1.8 Wind Tunnel Models	16
4.2 MANUFACTURING EVENTS/PRELIMINARY DESIGN PHASE	16
4.2.1 Preliminary Manufacturing Plan	19
4.2.2 Make/Buy Policy Decisions	19
4.2.3 Major Subcontractor Selection	19
4.2.4 Preliminary Tooling Plan	19
4.2.5 Facility Design (Assembly Line)	21
4.2.6 Producibility Trade Studies	21
4.2.7 Preliminary Specification Control Documents	21
4.2.8 Quality Control	22
4.2.9 CAD/CAM Refinement	22
4.2.10 Manufacturing and Materials Technology	22
4.2.11 Engineering Mockup Plan	22
4.2.12 Wind Tunnel Models	22

4.2.13	Program Schedule Plan	23
4.2.14	Cost Control Study	23
4.3	MANUFACTURING EVENTS/DETAIL DESIGN PHASE	23
4.3.1	Master Schedule	27
4.3.2	Procurement--Critical Material and Long Lead Items	27
4.3.3	Tool Design and Fabrication	27
4.3.4	Facilities	28
4.3.5	Purchase Orders and Specification Drawings	28
4.3.6	Manufacturing Plan	28
4.3.7	Quality Control Plan	28
4.3.8	Mathematical Definitions and Extractions	28
4.3.9	CAD/CAM Selection	29
4.3.10	Change Management	29
4.3.11	Mockup Plan	29
4.3.12	Manufacturing Review	32
4.3.13	Master Engineering Release Schedule	33
4.3.14	Make/Buy Subcontractor Decisions	33
4.3.15	Cost Data refinement	33
4.3.16	Engineering Liaison Plan	33
4.3.17	Structural Test Facilities	34
4.3.18	System Test Facilities	34
4.3.19	Wind Tunnel Models	34
4.4	MANUFACTURING EVENTS/FABRICATION PHASE	34
4.4.1	Drawing Receival	35
4.4.2	Part Lists keceival	35
4.4.3	Make/Buy Committee Action	41
4.4.4	Master Schedule release	41
4.4.5	Manufacturing Plan Release	41
4.4.6	Material Ordering	42
4.4.7	Work Chart Preparation	42
4.4.8	Tool Order Release	43
4.4.9	Implement Production Control Plan	43
4.4.10	Completion of Mock-up Plan	43
4.4.11	Implement quality Control Plan	43
4.4.12	Implement Liaison Plan	44
4.4.13	Detail Fabrication	44
4.4.14	Assembly Fabrication	44
4.4.15	Component Installation	44
4.4.16	Change Management	45
4.4.17	Material Review Board (MRB)	45
4.4.18	Flight Test, Acceptance, and Delivery	45
4.4.19	Static and Fatigue Test Programs	46
5.0	COMPUTER AIDED MANUFACTURING (CAM)	47

5.1	CAM TODAY	47
5.1.1	CAD System Output	47
5.1.2	CAM Systems	47
5.2	TRENDS IN MANUFACTURING TECHNOLOGY	58
5.2.1	Changing Manufacturing Techniques	58
5.2.2	Changing Computing Capabilities	60
5.2.3	New CAM Techniques	65
5.2.4	Classification and Coding	71
5.2.5	Quality Assurance	73
5.2.6	Organizational Restructuring	76
5.3	FORECASTS	78
5.3.1	Production Technology Advancements Forecast to 1988	78
5.3.2	AFCAM	83
5.3.3	CAM-I, A Viewpoint	85
5.4	CONCLUSIONS	86
6.0	IPAD SUPPORT REQUIREMENTS FOR PRODUCT MANUFACTURING	89
6.1	SUMMARY	89
6.2	GENERAL SUPPORT REQUIREMENTS	90
6.2.1	Manufacturing Use of Engineering Data	90
6.2.2	Information Flow	104
6.3	POSSIBLE BOUNDARIES BETWEEN DESIGN AND MANUFACTURING	115
6.3.1	Information From Design to Manufacturing	115
6.3.2	Information From Manufacturing to Engineering Design	117
6.3.3	Shared Information	117
6.4	OTHER SUPPORT CONSIDERATIONS	117
6.4.1	Management Information	123
6.4.2	Configuration Management	123
6.4.3	User Environment	123
6.4.4	Industrial Engineering	124
6.4.5	Manufacturing Cost Data	124

APPENDIX A	Manufacturing Organization	127
APPENDIX B	General Interfaces	133
APPENDIX C	Aerospace Industries Association (AIA)	146
APPENDIX D	Definitions	152
APPENDIX E	SI - U. S. Conversion Table	154
REFERENCES	155

TABLES

	<u>Page</u>
1. Information Required for Each Part	40
2. Drawing Sizes	109
3. Estimated Present Storage Size	110
4. Information Flow: Information Type Matrix	113
5. Information Access Requirements	116

FIGURES

	<u>Page</u>
1. Relationship of Task I Documents	4
2. Geometric Information Flow-Wing Design and Fabrication	5
3. Manufacturing Events/Conceptual Design Phase	13
4. Manufacturing Events/Preliminary Design Phase	17
6. Manufacturing Events/Detail Design Phase	24
7. 747-SP Subcontractors Using Computer Geometry Data	31
8. Manufacturing Events/Fabrication Phase	36
9. CAD/CAM System	49
10. Adaptive Control (Early Version)	56
11. Sheet Metal Center	70
12. Roll Forming	72
13. Classification and Coding	74
14. Example of Part Classification Code	75
15. Potential Scope of a Classification and Coding System	75
16. Advanced NC Machine In-process Monitoring Concept	77
17. Program Cost Summary	91
18. Data Interface	92
19. "Engineering" Configuration	95
20. "Manufacturing" Configuration	97
21. The "As-Planned" Configuration	99
22. Total Tooling	100

23.	Tool Engineering	101
24.	Aircraft Surface Definition Size Distribution	107
25.	Storage Requirements	108
26.	Engineering/Manufacturing Data Flow	112
27.	Design to Manufacturing--Conventional	118
28.	Manufacturing Utilization of IPAD	119
29.	Translated Storage	120
30.	Manufacturing Information for Design Support	121
31.	Shared Data	122
32.	Sample of Manufacturing Information to Design	126
33.	Manufacturing Organization	128
34.	CAD/CAM Control	135
35.	Engineering-Manufacturing Interaction	136
36.	Product Evolution	137
37.	AIA Organization Chart	147
38.	CAM-I Membership Organizational Structure	150
39.	CAM-I Staff Organizational Structure	151

1.0 SUMMARY

This document describes the product manufacturing interactions with the design process and, when used with the reference design process document (CR 2981), provides an overview of the design and manufacturing processes. An analysis of design/manufacturing/quality control interactions is provided for the total spectrum from conceptual design through delivery of the product.

Section 2.0 describes how the definition was developed and how the information in this document can be utilized by the various users. There will be an interface between this definition and the Air Force integrated computer-aided manufacturing (ICAM) program in the manufacturing architecture, classification, and coding and numerical control (NC) sheet metal center study areas.

Section 4.0 describes the manufacturing events that take place during the conceptual, preliminary and detail design, and the fabrication phases. The use of the IPAD system will impact these events in various ways--the impacts are anticipated and described.

Section 5.0 describes developments and trends in computer-aided manufacturing (CAM) and quality assurance technology and summarizes how the design of IPAD will be affected by the requirements to support the users of design information. Not all of these developments will be used by all companies, but the IPAD design must address them generally.

Section 6.0 describes more specifically the IPAD support requirements for the downstream users of the design information including the description and quantification of the information that passes between the design process and manufacturing. There are requirements that must be addressed in the Information Processing and Integration Requirements Document (CR 2984). The manufacturing user does not impose unique user requirements on the IPAD system designer.

2.0 INTRODUCTION

This document analyzes the interactions between design and manufacturing during the conception, design, and fabrication of an aerospace vehicle. This analysis includes the quality control interactions during the performance of the product verification functions. Special attention has been given to computer-aided functions in design, manufacturing, and quality assurance because of the conviction that these interactions will have the greatest impact on the design of IPAD (Integrated Programs for Aerospace-Vehicle Design) (ref. 1). An attempt has been made to illustrate, through presently visible trends in evolving technology, the IPAD user environment that will exist in the 1980's. Figure 1 illustrates the relationship of this document to other documents developed in task I of the IPAD program.

Use of commercial products or names of manufacturers in this report does not constitute official endorsement of such products or manufacturers, either expressed or implied, by the National Aeronautics and Space Administration.

2.1 SCOPE

The analysis of design/manufacturing/quality control interactions covers the total spectrum from conceptual design through delivery of the product. The basis for all interactions is information transfer: manufacturing preferences to design; product geometry and specifications to manufacturing; fabrication and producibility costs for trade studies; solutions for assembly problems; etc. Having accurate information available in the early stages of a new project and making it easily available to all potential users can have far-reaching impact on the reduction of flowtimes and costs to produce an aerospace product. The interactions are identified and the data transfers described generally. (See fig. 2 as an example of geometric information flow). Today's process is described, as well as trends likely to indicate the directions of the 1980's.

2.2 OBJECTIVE

This document describes the manufacturing process and its interactions with design in order to determine the extent of the potential impact of support requirements for manufacturing and quality control on the design of the IPAD system. Background is provided on the manufacturing process and the data processing systems that support its activities. It is intended that this definition be used in conjunction with the Design Process Definition document (CR 2981) to provide an overview of the total product definition and fabrication process. The combination of these documents will provide reference information for the

development of the user requirements specifications for the design of IPAD.

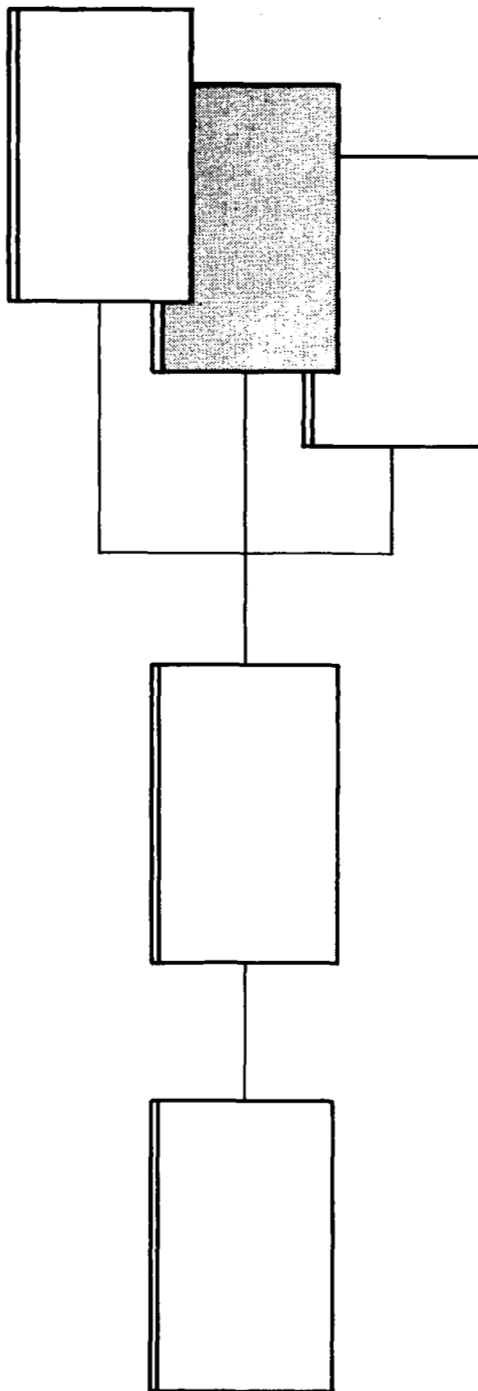

REFERENCE DESIGN PROCESS
CR 2981

**PRODUCT MANUFACTURE
INTERACTIONS WITH THE
DESIGN PROCESS**
CR 2982

**PRODUCT PROGRAM
MANAGEMENT SYSTEMS**
CR 2983

**INTEGRATED INFORMATION
PROCESSING REQUIREMENTS**
CR 2984

USER REQUIREMENTS
CR 2985

Figure 1.—Relationships of Task I Documents (Shaded block indicates this document.)

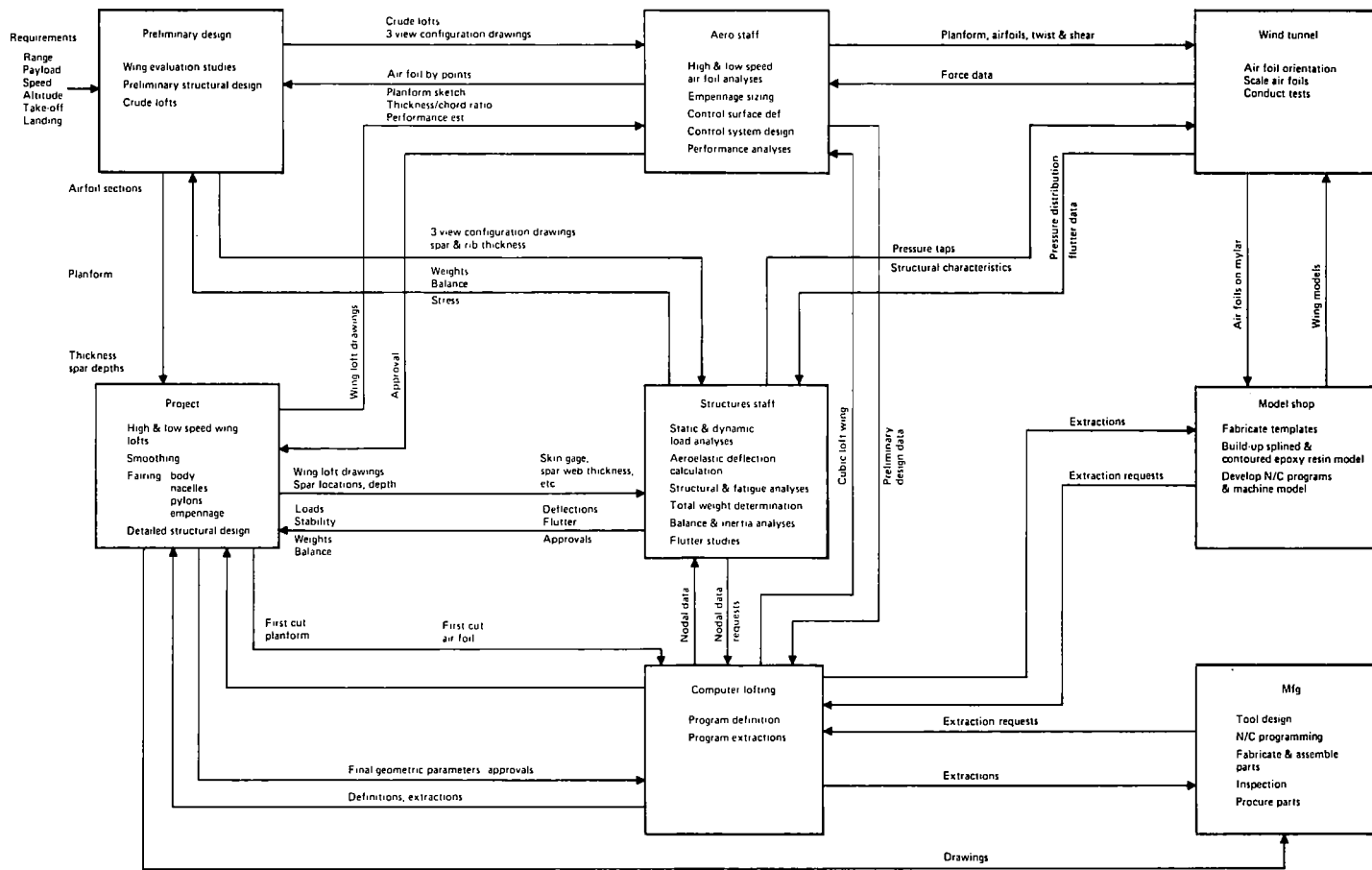

Figure 2.—Geometric Information Flow Wing Design and Fabrication

2.3 PURPOSE

This analysis was undertaken in order to support the development of user functional requirements on which the design of IPAD will be based. The combination of this document, the design process definition, and the product program management systems will be used to support the development of the information processing and integration requirements definition. All four of these will be used to develop the user functional requirements. This represents a universal description of the product design/manufacturing interactions for the aerospace industry.

2.4 APPROACH

People from line organizations and research and development have joined the IPAD team for periods ranging from three weeks to three months to assist with the development of this document. Representatives from manufacturing engineering, tool design, computer-aided manufacturing and quality control research and development have been included. The description of today's system and the developing trends have been put together with their assistance. Avenues to other organizations have been open for the exchange of ideas and the answering of specific questions that have arisen.

Use has been made of historical data and industrial studies that substantiate certain trends in aerospace manufacturing. For example, one such trend is the requirement for design numerical data in greater volumes than was previously required in order to support sheet metal numerical control centers. The sources of information include Aerospace Industries Association (AIA), CAM-I, and academic and government publications. The Air Force program, integrated computer-aided manufacture (ICAM), has been taken into consideration for its relationship to IPAD.

Section 4.0 has been developed to describe the manufacturing process. In order to develop the support requirements for manufacturing and quality control, it must be understood how these organizations operate and the events that take place during the design and manufacturing process. A flow chart for each phase has been prepared to support the description.

The functional flow charts represent a production program; an attempt has been made to generalize the Boeing process so that it can represent a typical aerospace manufacturing process. Adjustments must be made by each company to represent their processes; military programs, prototype and test vehicles, and pilot production programs will depart from this process to some extent. The diversity of company practices in these areas obviates the use of a general model.

The special technology being developed for computer-aided manufacturing and quality assurance is described in section 5.0. This includes the present state of the art and the trends that indicate where the technology will be in the next decade, when IPAD will be in use.

The design/manufacturing interfaces are described in section 6.0. The functional requirements that should be considered for the IPAD system design to support manufacturing and quality control are also described. These are the recommended priority support requirements that have been developed on the basis of this study.

2.5 USE OF THIS DOCUMENT

This document can be used with further analyses to determine how a specific company will support design/manufacturing functions using the IPAD system. A general analysis would be of little use at this time. Impact speculations are based on the IPAD concept described in the feasibility study (ref. 1).

Individual companies will have to make economic analyses for each potential system application in order to develop their IPAD system definitions. Some of the considerations will be:

Manufacturing requirements in terms of types of products, product characteristics, and quantities

The nature and capacity of the industry's current fixed plant and equipment relative to forecast production requirements:

Plant capacity

Age distribution/obsolescence of existing machine tools

Program arrangements that expand the geographical boundaries and complexity of the system (e.g., subcontract, international multipartner joint venture)

Availability of internally generated cash to support plant expansion and/or modernization

Relative cost trends of key resources, e.g., manpower versus computing; energy cost and availability

Other impacts, e.g., environmental legislation, OSHA, etc.

This document can also be used:

a) For the general reviewer and potential IPAD user:

- 1) As an overview of the product manufacturing process. Section 4.0 provides a description of a commercial production process with potential effects of an integrated system such as IPAD.
 - 2) As a discussion on the developments and trends in computer-aided manufacturing (CAM) and quality assurance technology. These are discussed as they may relate to IPAD system design. This document also serves as reference information for the development of IPAD support requirements.
- b) For the IPAD system designer:
- 3) Section 6.0 describes the general IPAD support requirements for the product manufacture process and quantifies the design data as experienced on Boeing commercial production programs. Specific considerations for the various manufacturing disciplines are described.
 - 4) It is anticipated that the Air Force ICAM program will have some interface with this definition, primarily in the manufacturing architecture description, classification and coding, and the NC sheet metal center study areas. There will be interactions at a future time between IPAD and ICAM. This document can be used to help define those interactions.

3.0 ACRONYMS AND ABBREVIATIONS

AC	Adaptive control
AIA	Aerospace Industries Association (see Appendix C)
AFCAM	Air Force Computer-Aided Manufacturing (see ref. 7)
AMR	Advance material release
APT	Automatically programmed tools
CAD	Computer-aided design
CAM	Computer-aided manufacturing
CAM-I	Computer-Aided Manufacturing - International, Inc.
CAP	Computer-aided planning
CIRP	College International for Research Production
CNC	Computer numerical control
CPU	Computer processing unit
CRT	Cathode ray tube
C&C	Classification and coding
DNC	Distributed numerical control
DOD	Department of Defense
EXAPT	Extended APT
IC	Integrated circuit
ICAM	Integrated computer-aided manufacturing
ICG	Interactive computer graphics
I/O	Input/output
IPAD	Integrated Programs for Aerospace-Vehicle Design
IPEX	IPAD executive
IPIP	IPAD information processor
MRB	Material Review Board

NC	Numerical control
OSHA	Occupation Safety and Health Administration
P/N	Part number
QAR	Quality assurance report
QC	Quality control
ROI	Return on investment
SDA	Substitute design authorization
WBS	Work breakdown structure
2D	Two dimension
3D	Three dimension

4.0 THE MANUFACTURING PROCESS

This section describes the manufacturing organization and general functions and develops the basic manufacturing and quality control events through the conceptual, preliminary, detail design, and fabrication phases of a product. It discusses the data requirements in a general way. These phases overlap in such a way that the identification of which phase a specific activity takes place in may vary from product to product or company to company.

Recommendations are included for new ways of doing business to take advantage of the IPAD information base. Changes in activity descriptions are contained in "IPAD IMPACT" paragraphs. These paragraphs are judgments based on the concept of IPAD described in the feasibility study (ref. 1) and are really potential impacts depending on how each company wants to use the system. The "IPAD IMPACT" statements may imply an extension beyond the basic IPAD system; this represents the idea that present and future application programs may be integrated with IPAD. It may be that the applications described are not economically feasible (sec. 2.5) for all companies. A major trend is the build-up of manufacturing support earlier in the conceptual and preliminary phases of a program and a relative leveling of the people needs in the later program phases. This is based on an exchange of design/manufacturing information using IPAD and the ability of manufacturing to make firm decisions earlier in the program phases. This also results in the reduction of design changes during the fabrication phase.

The functions of an aerospace company's manufacturing organization are universal but may appear under various organizational labels in the different companies. An example of a company organization is contained in appendix A with descriptions of the several functions.

The basic manufacturing functions do not change just because IPAD is being used. IPAD imposes no constraints to force changes. Rather, there will be a natural trend to change in order to use IPAD and other systems linked to IPAD in the most efficient manner. We cannot forecast specific changes in the manufacturing process during the 1980's. Each company will respond differently because of their unique mix of IPAD and systems linked to or supported by IPAD. Functions that are performed today during the manufacturing process will not disappear. They may be combined or they may look different; there may be manual functions that will be performed within a computer system. There are computer system developments independent of IPAD that will contribute to changing the way functions are performed today. Although we cannot forecast specific changes, we do discuss general trends of change in the manufacturing process.

Two major areas of computer support in manufacturing have evolved in parallel; these may be considered as "business" systems (e.g., inventory control, cost collection, and process order preparation) and "scientific" systems that include numerical control, mathematical definition, and tool design analysis. In both areas, proliferation of system development has taken place over the years with little, if any, effort to provide compatibilities and standards for later integration. Functional organizations have tended to develop their own systems requirements without coordinating with other organizations. In recent years, this trend has continued as minicomputers have appeared on the scene to control production and design processes: independent and distributed systems have been developed without an overall plan. This situation has been changing over the last few years however, partly due to escalating computing system development costs. Large systems are being designed and built using modular techniques, while smaller systems are being designed for integration with other systems on a division or company basis.

The following discussion of events represents a general concept of the aerospace industry manufacturing process as it exists today, with descriptions of the impact of utilizing IPAD in the 1980's. At the turn of the decade, only those systems already under development (or firmly planned) will be in use. New capabilities and system applications will continue to be developed and implemented throughout the decade. Where each aerospace company stands at that time in relation to this universal concept depends on many variables.

4.1 MANUFACTURING EVENTS/CONCEPTUAL DESIGN PHASE

Manufacturing activity during this phase today consists primarily of staff functions rather than project. Unless the new product is a derivative of an existing model, the manufacturing project is not organized until the go-ahead for preliminary design. The interfaces during this phase will primarily provide information to support high-level decision-making related to broad manufacturing capabilities and relative product cost. (See figure 3.)

IPAD IMPACT:

A team of design, manufacturing, and quality control people can be utilized to quickly screen the product concepts as they are developed and thus speed the selection process. Input of engineering and manufacturing information into the IPAD data base enables company resources, plans, and schedules to be summarized for review. Alternatives are compared by analytical and

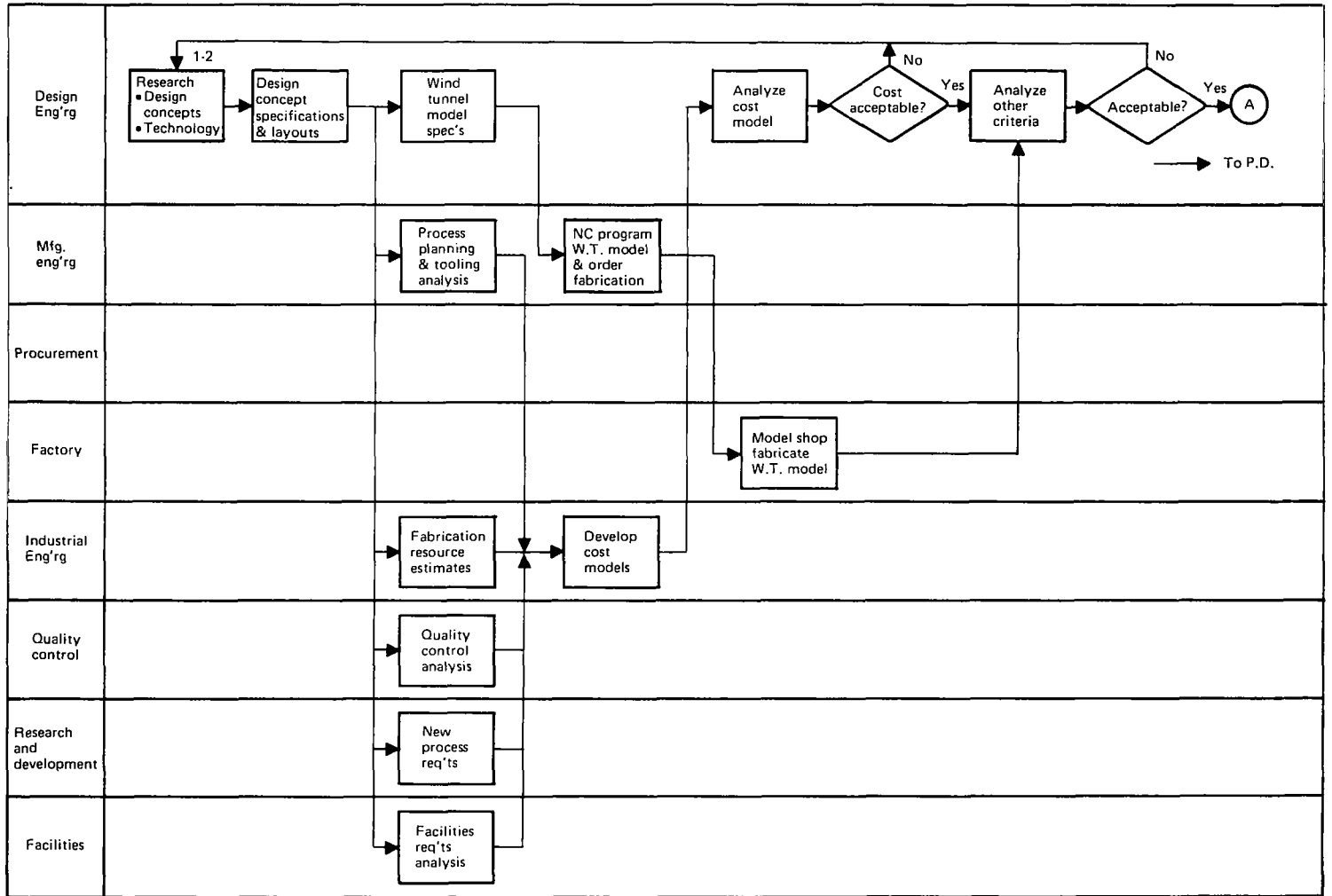

Figure 3.—Manufacturing Events Conceptual Design Phase

graphic methods to determine optimum conditions. Use of interactive graphics to draw charts and flow diagrams will enable all alternatives to be considered quickly.

4.1.1 FACILITY REQUIREMENTS ANALYSIS

A preliminary survey of existing facilities based on the time period for the product introduction is undertaken for the various concepts. This includes the potential requirement to expand or add facilities as well as cost estimates for their preparation.

IPAD IMPACT:

Graphical display of existing facilities will make it easier to expand or to delete facilities and explore all the possibilities for long- and short-term goals. Cost estimates for each possibility are run through the computer and compared with each other.

4.1.2 FABRICATION RESOURCE ESTIMATES

Cost analyses to build the several concepts of new products affect the go-ahead decisions. Considerations of new processes, available skills, and facilities are included in the analyses.

IPAD IMPACT:

Go-ahead decisions will be made with more confidence as information available in the IPAD system reduces the decision risk. Direct labor estimates for fabrication and assembly, as well as tooling, planning, and other direct and indirect labor and material costs, lend themselves to computerization via IPAD. (This assumes that IPAD is based on the concept of coding discrete items in design and making the data available to manufacturing via a data base.)

4.1.3 MATERIAL AND PROCESS DEVELOPMENT

Manufacturing technology tests new materials and develops fabrication and preparation processes that satisfy design specifications. This is an ongoing research and development effort, for new materials inevitably result in the development of new processes and facilities.

IPAD IMPACT:

Grouping of new materials, applications, and facilities by family in the computer and the ability to recall this information will give engineering and manufacturing up-to-date technology on

demand. The tedious job of literature research and cataloging of information is avoided if the information is available from a central computer for company-wide use.

4.1.4 CAD/CAM DEVELOPMENTS

The CAD/CAM systems that are selected for development have been analyzed for return on investment (ROI) and have met the criteria for successful production applications. The ROI analyses can be used to predict cost and schedule impact on a new product. Experience has shown that as these systems become integrated (with IPAD in this case), the combined benefits will be greater than the sum of the benefits of the individual systems. The basic interface between the CAD and CAM systems is the geometry of the product.

4.1.5 MAJOR TOOLING ANALYSIS

A study of basic tooling concepts is performed to obtain general costs and identify possible problems associated with broad requirements of putting a new design concept into production.

IPAD IMPACT:

Historical tooling concepts and cost information is available for use as well as the identification of tooling and tool designs that can be used on a new product.

4.1.6 QUALITY ASSURANCE TECHNOLOGY

In support of a new design concept, quality control system developments and test facilities affecting product cost and schedules are reviewed. These developments have been analyzed in the same manner as CAD/CAM systems and the information is available for project assessment.

IPAD IMPACT:

Quality control plans and concepts can be indexed and compared with historical information.

4.1.7 COST STUDIES

Potential schedules and production quantities must be established during the conceptual phase for use in a general analysis of facilities requirements, fabrication resources, and overall cost studies. Each design concept must be reviewed for probable program costs as a significant item of evaluation.

IPAD IMPACT:

Mathematical models are defined for the various conditions that affect schedules and quantities. Optimum conditions are chosen for the final result. Each design concept must be reviewed for probable program costs as a significant item of evaluation. Cost feasibility studies of design concepts are evaluated by management systems. These results are displayed and plotted for management review. Similar historical cost data can be compared.

4.1.8 WIND TUNNEL MODELS

This is a direct interface that may begin in the conceptual design phase. Wind tunnel tests are essential in determining the potential application of design concept.

IPAD IMPACT:

The geometry for NC machining of wind tunnel models is made available for each design concept that is to be tested. This geometry will reside in the IPAD data base as long as that concept is a candidate for development. This interface exists throughout the product development phases.

4.2 MANUFACTURING EVENTS/PRELIMINARY DESIGN PHASE

The preliminary design (PD) go-ahead triggers the project's manufacturing and quality control organizations to support product fabrication. These are skeletal organizations that will build up for the subsequent detail design and fabrication phases. Information developed for the preliminary design phase will be a refinement of the conceptual design phase based on more detailed and complete information from design. (See figure 4.)

IPAD IMPACT:

The team concept used for the conceptual design phase experiences a smooth transition as improved design information becomes available. Manufacturing and quality control manpower expands as the available concepts are narrowed for preliminary design go-ahead. The IPAD data base is used by the team to develop manufacturing and tooling plans based on past programs as well as the new design data. Hard decisions can be made earlier in this phase and reduce the large manpower buildups usually required downstream to generate process orders and related paper.

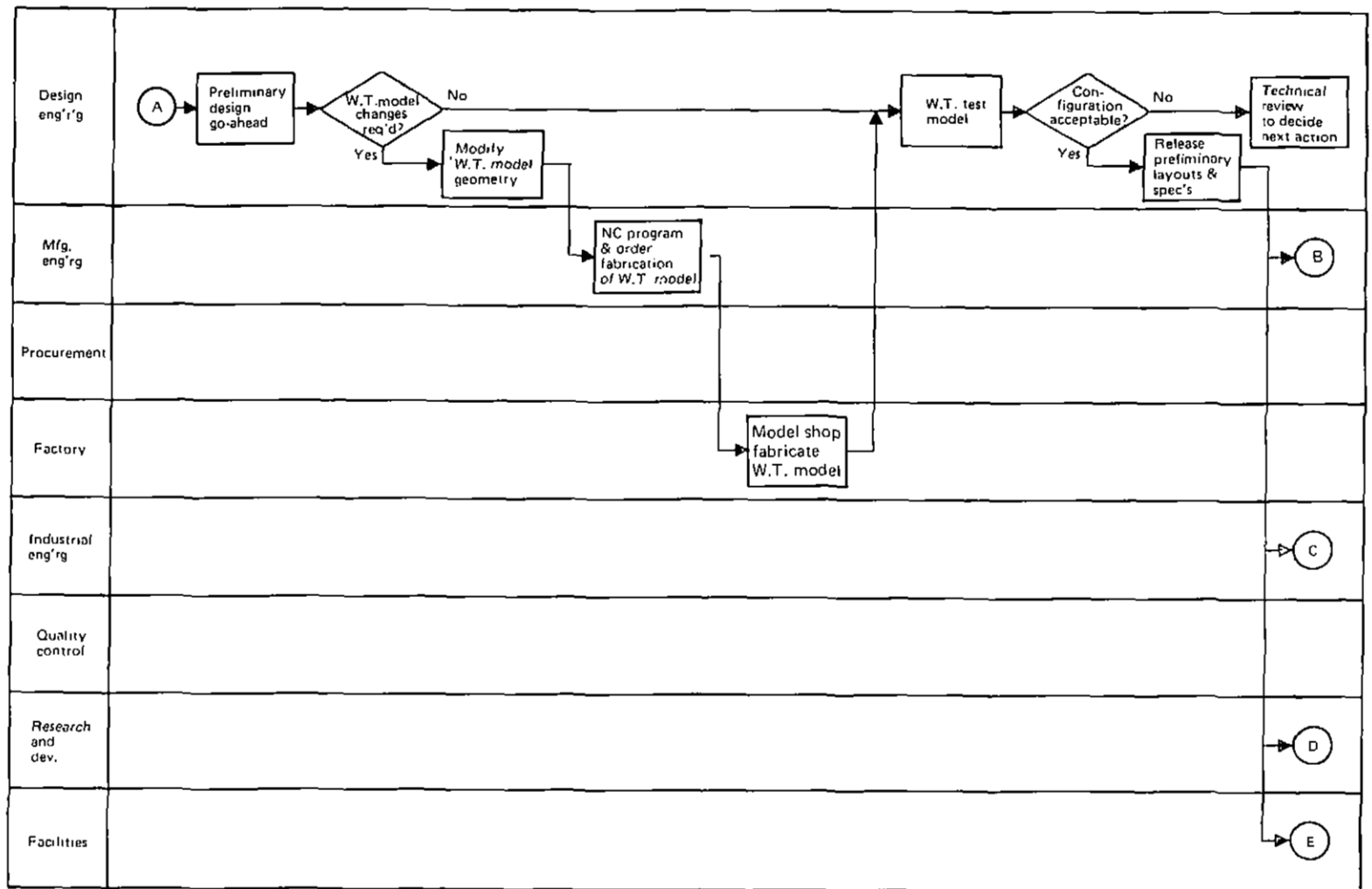

Figure 4.—Manufacturing Events Preliminary Design Phase

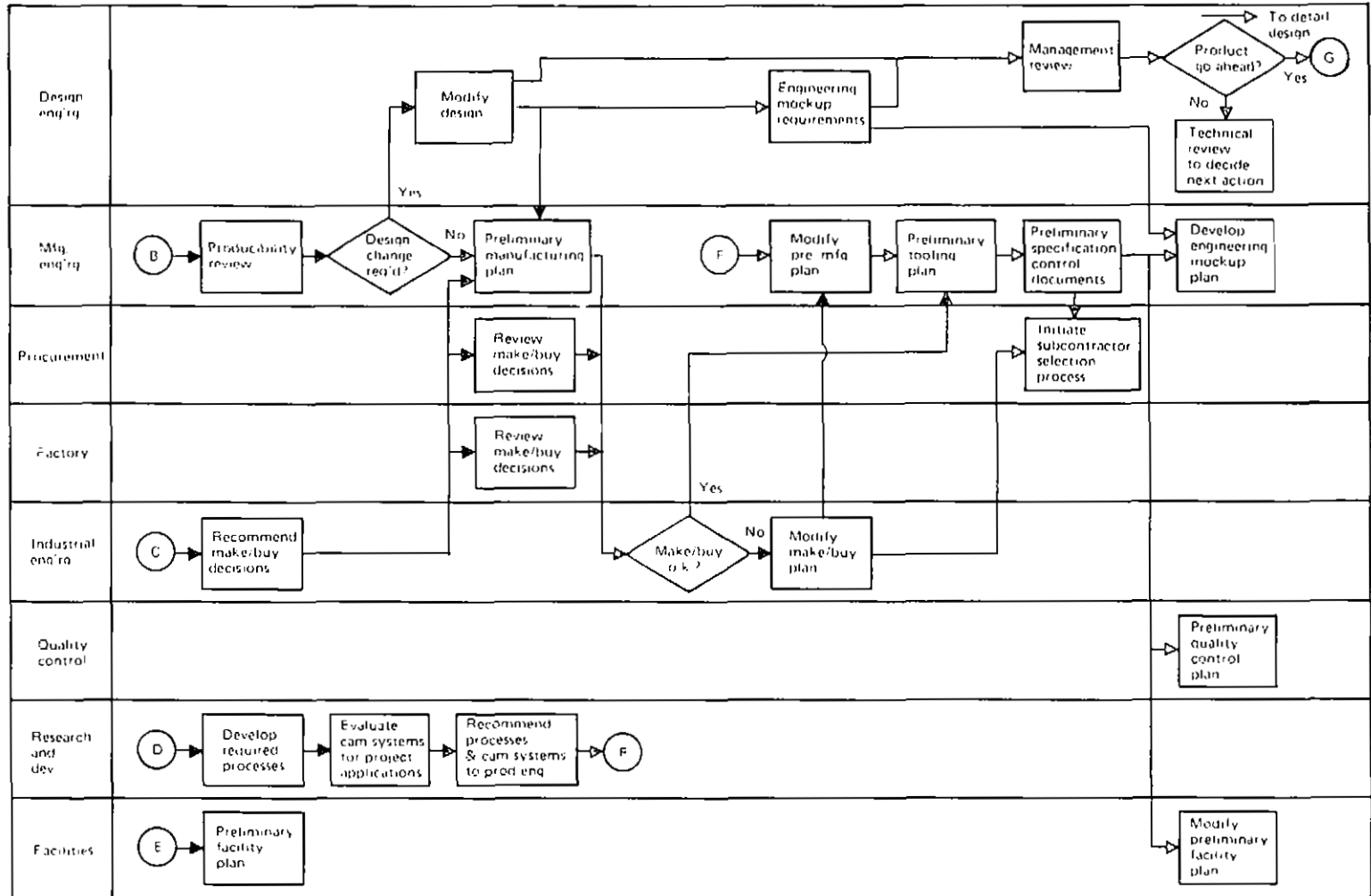

Figure 4.—Manufacturing Events Preliminary Design Phase (Concluded)

4.2.1 PRELIMINARY MANUFACTURING PLAN

The general plan for fabricating the product is developed, based on design information. It defines the general manufacturing and tooling concept to be used to establish in-house resource requirements and basic schedule compatibility.

IPAD IMPACT:

As the design information becomes available in the data base, the preliminary process planning is generated.

Assembly breakdowns are included as completely as possible. Priorities are established for sequence of manufacturing. New process requirements are introduced to support the new materials used in the product. (See figure 5.)

4.2.2 MAKE/BUY POLICY DECISIONS

Based on design/manufacturing coordination meetings, make-or-buy decisions are made for major structure sections, components (landing gear, engines, etc.), and systems.

IPAD IMPACT:

If IPAD contains a coded data base, a direct application of data within it can simulate a "balance" between make and buy which could take into account traditional approaches, contractor strengths/weaknesses, state of the art, etc., so that make/buy policy is established on the basis of consistent evaluations.

4.2.3 MAJOR SUBCONTRACTOR SELECTION

Manufacturing begins selection of subcontractors for long-lead "buy" items.

IPAD IMPACT:

A historical data bank would be invaluable in analyzing the performance of subcontractors by emphasizing strengths (quality, price, schedule adherence, etc.).

4.2.4 PRELIMINARY TOOLING PLAN

Based on design layouts and item descriptions, basic plans are made for master tooling requirements, large assembly tools, work platforms, and major handling equipment.

IPAD IMPACT:

CAD/CAM items are selected and the need for master tools is closely examined. In areas where the data base mathematical definition is complete, master tools may not be required. Tool designs from other products are reviewed and utilized, when possible.

4.2.5 FACILITY DESIGN (ASSEMBLY LINE)

In conjunction with the manufacturing and tooling plans, the facilities requirements are estimated and designed for all aspects of the program including engineering, tooling, fabrication, test, and delivery. Construction begins on specific long-lead projects that are firmly identified.

4.2.6 PRODUCIBILITY TRADE STUDIES

Manufacturing reviews the design in the layout phase to assure that design decisions support cost effective fabrication and assembly practices. The reviews are initiated at the discretion of the design project in order to augment trade studies at critical decision points. Manufacturing looks at various design aspects such as material, size and assembly arrangements from the viewpoint of available company resources and fabrication capabilities. The layouts are also used to develop preliminary manufacturing and tooling plans, which in turn may initiate design revision requests from manufacturing. The producibility reviews constitute a continuous dialogue between design and manufacturing on both a formal and informal basis. Quality control aspects are also reviewed during this process to verify that the design intent has been achieved.

IPAD IMPACT:

Use of CAD output and new methods of fabrication and assembly of details are examined. Old and new trade studies are modeled and compared to each other. The various manufacturing approaches are then analyzed to determine cost effectiveness. A properly coded design data base will automatically identify families of parts by frequency of occurrence. This information can be used to optimize producibility decisions.

4.2.7 PRELIMINARY SPECIFICATION CONTROL DOCUMENTS

Procurement reviews preliminary design specifications for purchased items.

IPAD IMPACT:

Control documents are computerized and run for review of purchased items. Industry-wide standards are incorporated so common tools and equipment may be used. Existing specifications from other products can be reviewed and utilized.

4.2.8 QUALITY CONTROL

Preliminary quality assurance plans are developed to support tooling, fabrication, assembly, and test operations. Existing plans from other products can be reviewed and utilized.

4.2.9 CAD/CAM REFINEMENT

CAD/CAM candidate priorities are established and resource requirements identified. The computerized mathematical definition of the product is developed for CAD/CAM and subcontractor applications.

4.2.10 MANUFACTURING AND MATERIALS TECHNOLOGY

Current and advanced materials, processes, and fabrication methods are researched and tested to benefit design requirements.

IPAD IMPACT:

The data is fed back to applicable engineering and manufacturing systems so as to benefit the product and future designs.

4.2.11 ENGINEERING MOCKUP PLAN

The engineering mockup plan is developed by manufacturing using preliminary sketches, to aid in generating the basic configuration for space arrangement and to illustrate customer features and sales items.

IPAD IMPACT:

Consideration of the information to be made available in the IPAD data base will influence the mockup plan.

4.2.12 WIND TUNNEL MODELS

Manufacturing continues to fabricate wind tunnel models to design specifications. Design data for the wind tunnel models are represented by a computerized mathematical definition used to fabricate the models by numerical control.

4.2.13 PROGRAM SCHEDULE PLAN

Design will provide operations, marketing, and finance with plans and scheduling information. It will include an estimate of the engineering release schedule, the configuration verification test plan, and the manufacturing schedule. It will also include identification of critical long-lead items (e.g., engines, forgings, etc.) and procurement criteria.

4.2.14 COST CONTROL STUDY

Initial program cost estimates are refined based on the design criteria, manufacturing reviews, the program schedule plan, preliminary manufacturing plan, facility plan, preliminary tooling plan, and other activity developed during the preliminary design phase. Initial program cost estimates include several production quantities. An assessment is made of the production costs over a time period, accounting for changes in the manufacturing schedule for introduction of new customer configurations and the impact of derivatives from the base model. An estimate is made of return on investment and cash flow by year.

4.3 MANUFACTURING EVENTS/DETAIL DESIGN PHASE

After critical design reviews of the product have been passed by design and manufacturing, the go-ahead is given to release design data to manufacturing. In this phase the design is refined and the details and components are designed in preparation for release. Manufacturing and quality control refine their plans based on more complete design data. (See figure 6.)

IPAD IMPACT:

Geometry and related information for components, assemblies and installations are released to the IPAD data base in accordance with the master schedule and utilized by manufacturing and quality control for the fabrication processes. Integration of program capabilities provides more efficient communication and utilization of information. Standard design features (radii, angles, hole sizes, etc.) yield standard manufacturing processes, which result in reduced production costs.

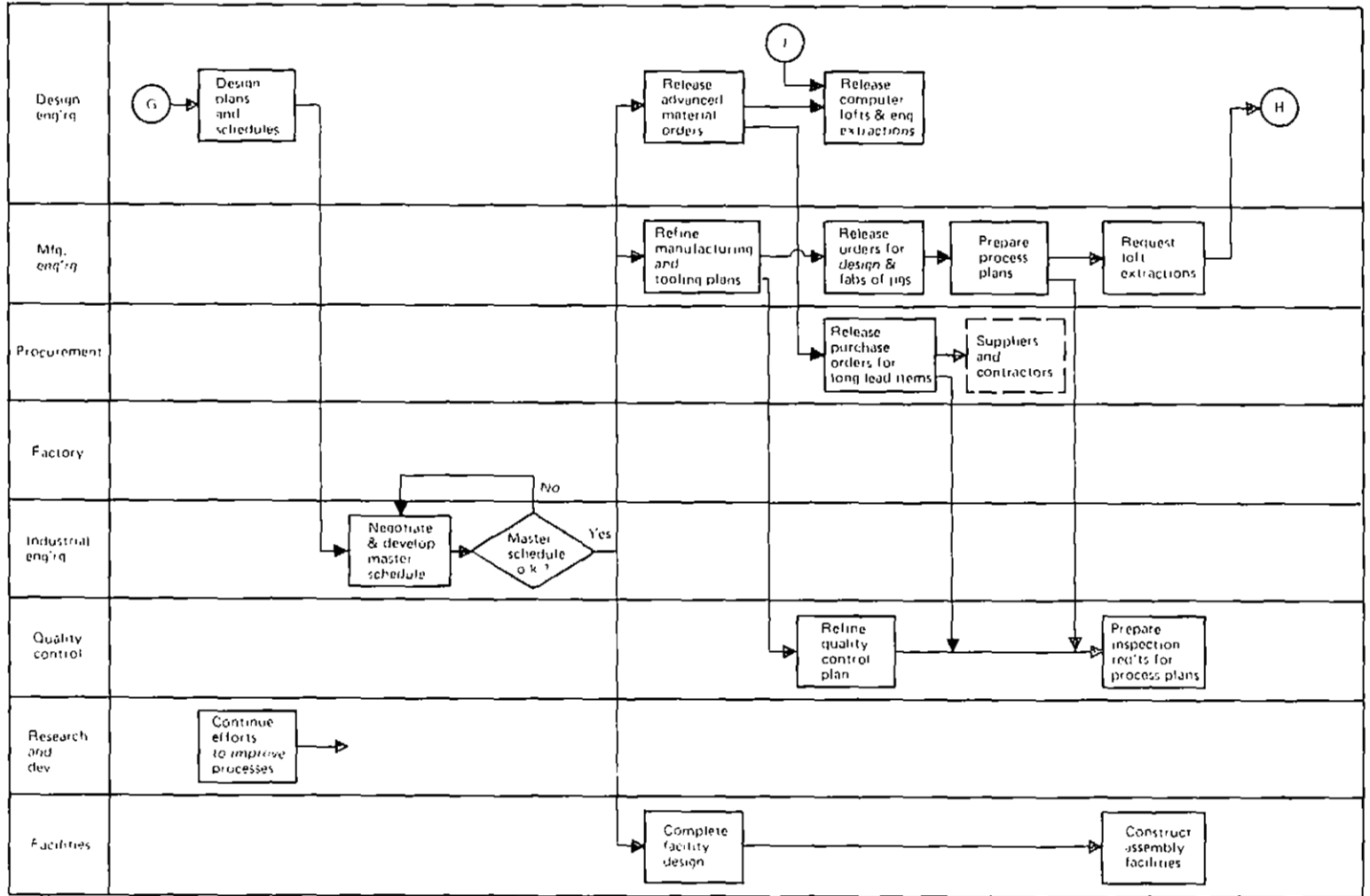

Figure 6.—Manufacturing Events Detail Design Phase

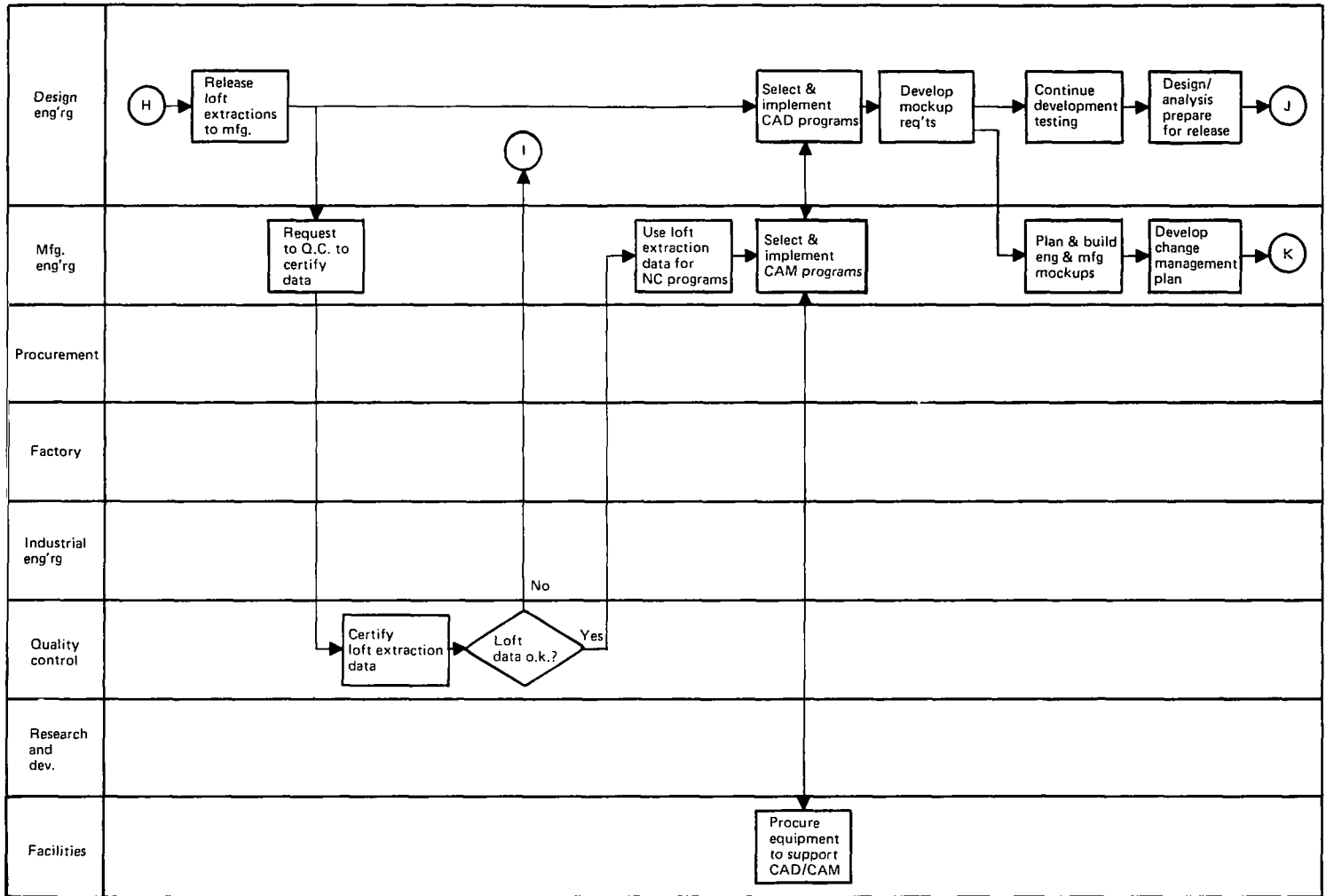

Figure 6.—Manufacturing Events Detail Design Phase (Continued)

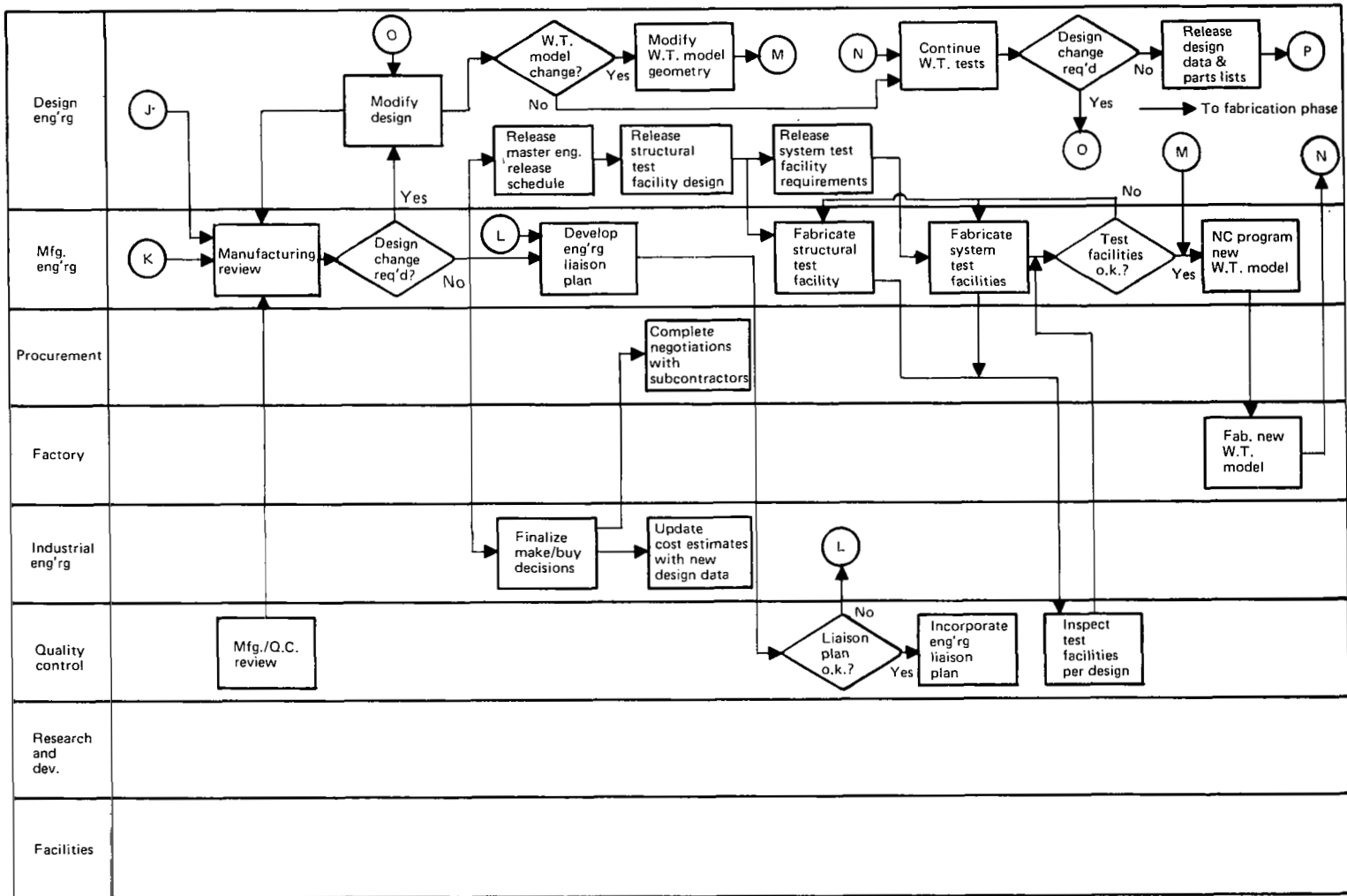

Figure 6.—Manufacturing Events Detail Design Phase (Concluded)

4.3.1 MASTER SCHEDULE

Engineering design provides plans and scheduling information to program management, operations, marketing, and finance. From this information, industrial engineering develops a master schedule in conjunction with other manufacturing organizations. Schedule-sensitive work packages are identified and design releases are scheduled, followed by schedules for fabrication, tooling, assembly and installation. Identification of critical schedule items (e.g., forgings is refined from the preliminary design phase.)

IPAD IMPACT:

The master schedule can be developed on a computerized base and readily updated during the detail design and fabrication phases.

4.3.2 PROCUREMENT--CRITICAL MATERIAL AND LONG-LEAD ITEMS

Engineering design releases advanced orders to procurement for purchase of critical material and long-lead items.

IPAD IMPACT:

Advanced orders are released for procurement of long-lead items, based on information in the data base.

4.3.3 TOOL DESIGN AND FABRICATION

Manufacturing releases orders for major tooling jigs, handling equipment, etc. The balance of the tooling program is prepared according to the master schedule, and the tooling orders are forwarded to tool design as engineering data becomes available. Final tooling plans are based on the final release of engineering data.

IPAD IMPACT:

Tool order release is accomplished via the terminal and resides in the manufacturing data base. A printed copy can be requested.

Tool design uses the IPAD utility programs for analysis and design preparation. The part geometry is available for direct access from the IPAD data base.

4.3.4 FACILITIES

Facilities refines estimates and designs made under the preliminary design phase. Long-lead items are ordered. Detail facility drawings are prepared to outline floor space and equipment for engineering, tooling, fabrication, test, delivery, and other support organizations. Go-ahead for construction is given.

IPAD IMPACT:

Facilities engineers develop their layouts using the IPAD graphics capabilities.

4.3.5 PURCHASE ORDERS AND SPECIFICATION DRAWINGS

Manufacturing reviews specification control documents and releases orders to Procurement for purchase of long-lead castings, standards, etc. The purchased equipment document is reviewed and the method of purchase coordinated.

4.3.6 MANUFACTURING PLAN

The preliminary manufacturing plan is refined as an outline for the entire fabrication process. Detailed manufacturing plans are developed as engineering data becomes available. Documentation is prepared and released outlining the basic plan for incorporation of hardware. Process plans are prepared and released through the manufacturing process planning system.

4.3.7 QUALITY CONTROL PLAN

A detailed plan is prepared that defines the inspection criteria for the program. The plan addresses tooling, detailed part fabrication, subassembly, final assembly, preflight, flight test, receiving, source control, functional test, calibration certification, geometry, statistical quality control, and other pertinent functions of quality control. The inspection requirements are added to the process plans.

4.3.8 MATHEMATICAL DEFINITIONS AND EXTRACTIONS

The extent of the computer lofting effort is determined. The engineering design concept is reviewed for lofting. A plan is prepared to utilize the computer mathematical model to its maximum benefits and identify need for extraction capabilities.

Extractions are required for CAM applications and subcontractor utilization. Quality control certifies the data and system software. (See figure 7 for subcontractor utilization examples.)

4.3.9 CAD/CAM SELECTION

New candidates submitted under preliminary design are firmed up and methods of application are coordinated. Working procedures are established to control CAD/CAM activities between engineering and manufacturing in order to obtain maximum benefit from the use of CAD/CAM.

IPAD IMPACT:

Selected CAD/CAM programs are integrated with IPAD.

4.3.10 CHANGE MANAGEMENT

A change management plan is developed for all phases of the product including hardware, software, design documentation, procurement, and delivery.

IPAD IMPACT:

Change management is controlled by the IPAD data base. This data base has input from the various engineering disciplines and from manufacturing. Different levels of information are present, and lateral and vertical transfer of information is accomplished interactively and by computer graphics. The IPAD system, which is developed to respond to company needs from conceptual through detailed design, interfaces and integrates with CAD/CAM and product servicing.

4.3.11 MOCKUP PLAN

The engineering class II mockup is coordinated and fabricated to provide more detail of the airplane structure and to evaluate full-scale structure and component installation concepts. The class II mockup includes moving parts where required and provides final checkout information for engineering evaluation between design groups. The manufacturing class III mockup is also coordinated and fabrication is begun to represent the exact production airplane structure. The class III mockup is made from final engineering information and is used for engineering and manufacturing evaluation of the airplane structure and systems arrangement. It is used to develop tubing, wiring, thermal and acoustic lining, and other parts that are not fully detailed by engineering. Drawings are prepared which show wiring and tubing,

routing, and noncritical hole locations. These drawings are approved by engineering and are used for installing systems in the production airplane.

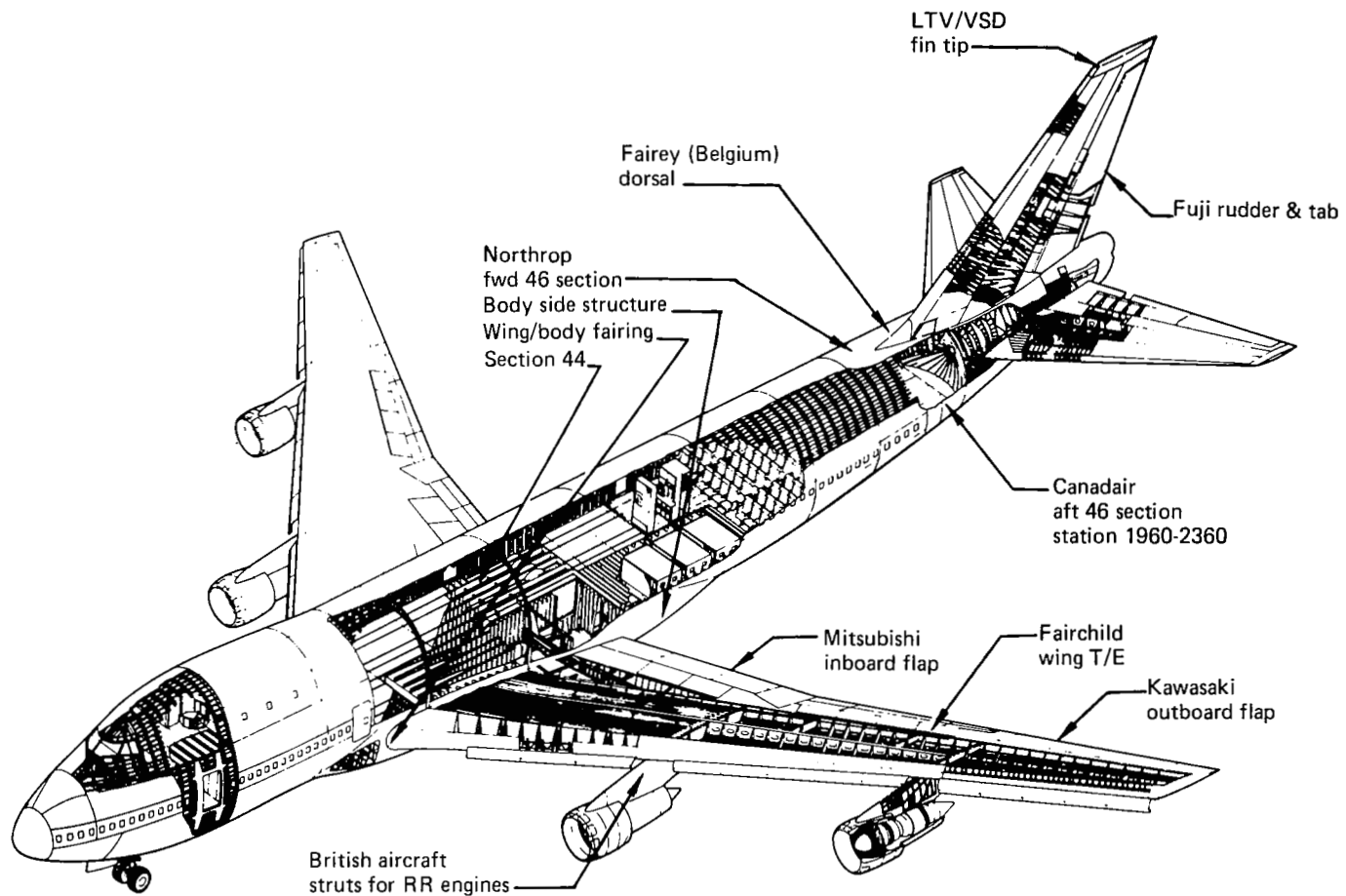

Figure 7.—747-SP Subcontractors Using Computer Geometry Data

IPAD IMPACT:

The ability to interact with engineering and other manufacturing organizations will greatly simplify the mock-up plan. Prior to IPAD, it was necessary to construct full-size vehicles for evaluating engineering design and determining wiring, tubing, and lining locations. IPAD will provide the capability to eliminate, or drastically reduce, the requirement for full-size vehicles. The 3D graphics feature of IPAD will allow the designer to display and manipulate the location of systems components in much the same way as the mock-up vehicles did. Once the designer is satisfied that the locations of the components do not conflict, the design can be approved and made available to other organizations. Manufacturing will then be able to extract the necessary information directly from the approved graphics display in order to determine routing, wire lengths, hole location, and hardware necessary to make a satisfactory installation. The interactive capability will also allow the transfer of noncritical hole locations (those required for system hardware) to be transferred by computer to the detail parts and other parts that are not fully detailed by engineering. Drawings are prepared which show routing of wiring, tubing, and non-critical hole locations. These drawings are approved by engineering and used for installing systems in the product.

4.3.12 MANUFACTURING REVIEW

Manufacturing reviews drawings prior to release for considerations similar to the layout phase and, in addition, to monitor schedule aspects. At this point, only minor revisions can be recommended without jeopardizing release schedules on schedule-sensitive items. Any discrepancies in the design can be noted at this stage and corrections requested. Again, quality control reviews the drawings to verify that design intent can be verified during fabrication and assembly operations.

IPAD IMPACT:

Manufacturing monitors schedule sensitive releases from engineering to assure that manufacturing can be responsive. IPAD provides the capability to display, graphically, schedules of critical items which require close scrutiny. Manufacturing can monitor these critical items more easily and negotiate and coordinate changes to the schedule through the terminal. All organizations have immediate access to all schedules and schedule adjustments.

4.3.13 MASTER ENGINEERING RELEASE SCHEDULE

Engineering releases are negotiated, coordinated, and documented to identify scheduled commitments for release of engineering data such as drawings, advanced material requirements, long-lead items, specification control drawings, etc.

IPAD IMPACT:

The negotiations of releases under IPAD are similar to the present system. However, once negotiations are complete the release schedule is made readily available, graphically, to all organizations. The schedule information includes dependencies and is used to pinpoint problem areas.

4.3.14 MAKE/BUY SUBCONTRACTOR DECISIONS

Make-or-buy decisions are finalized and negotiations with subcontractors are completed as engineering information becomes available.

IPAD IMPACT:

Cataloging of subcontractor information assists the selection process.

4.3.15 COST DATA REFINEMENT

Previous program cost estimates are refined and updated to maintain visibility of the overall program and of alternate decisions regarding design and/or manufacturing considerations. The identification of CAD/CAM candidates, the necessity of engineering changes, and assignment of subcontractors, all affect program costs.

IPAD IMPACT:

As the design progresses, the IPAD data base is continually updated. A cost model can be manipulated to illustrate "what if" consequences.

4.3.16 ENGINEERING LIAISON PLAN

A plan is developed to assure a timely response by engineering to design change requests based on improved cost and schedule developments or on other design considerations. A continuous interaction is necessary between engineering and manufacturing as drawings are released and modified.

IPAD IMPACT:

The IPAD data base facilitates the interactions; configuration fixes can be immediately documented.

4.3.17 STRUCTURAL TEST FACILITIES

Structural test facilities are designed and fabricated to support the test program directed toward structural details such as wing body joints, areas of load distribution, etc.

IPAD IMPACT:

The IPAD programs are available to the test facility designers. Refinement of analytical data may reduce test facility requirements.

4.3.18 SYSTEM TEST FACILITIES

System test facilities are designed and fabricated to verify that performance of each system is as predicted, is an acceptable deviation, or should be modified as test results indicate. System test facilities must accept partial or total systems for flight controls, hydraulics, electricity, electronics, etc.

IPAD IMPACT:

The systems which the facilities are designed to test are defined in the IPAD data base and are accessible to the facility designer. The IPAD programs are also available. Test facility requirements are reduced as a result of analytical capabilities in IPAD.

4.3.19 WIND TUNNEL MODELS

Wind tunnel tests are continued to provide data on vehicle performance. New models are required as the designs are refined.

IPAD IMPACT:

The geometry is directly accessible by the NC programmer from the IPAD data base. There will be a reduction in the need for physical models.

4.4 MANUFACTURING EVENTS/FABRICATION PHASE

This phase begins as the first design releases become available and continues as long as the product is being built and

delivered. Design changes due to engineering improvements and manufacturing problems comprise the remainder of the engineering-manufacturing interactions. (See figure 8.)

IPAD IMPACT:

In past programs, a penalty in cost and flowtime has resulted from incorporating design changes both in and out of normal fabrication sequence. The team concept (described in 4.1) used in conjunction with IPAD substantially reduces design changes and their resultant impact on the fabrication process.

4.4.1 DRAWING RECEIVAL

The receipt of engineering drawings from the release unit triggers the start of the normal production cycle. After the drawings are recorded by control file personnel for tracking purposes, the drawings are released to the responsible manufacturing organizations.

IPAD IMPACT:

The interchange between manufacturing and engineering during the design phase insures a release of an economically produced product requiring fewer changes. The approval by engineering of each definition triggers its immediate release to other organizations through the graphics terminals. Manufacturing has access to the design much earlier than at present, as data is available immediately through the graphics terminal. Control of the design releases during the manufacturing cycle is accomplished by input of schedules to the computer.

4.4.2 PART LISTS RECEIVAL

Parts lists are released to manufacturing by engineering. Manufacturing enters "codes" to the part lists to reflect in-house manufacture or purchase, etc. This information is then distributed to other affected organizations. (See table 1.)

IPAD IMPACT:

The physical release of part lists is not necessary under IPAD. By use of the terminal, special manufacturing codes can be input directly to the computer for each part number. Access to the information by all organizations can be made through each terminal.

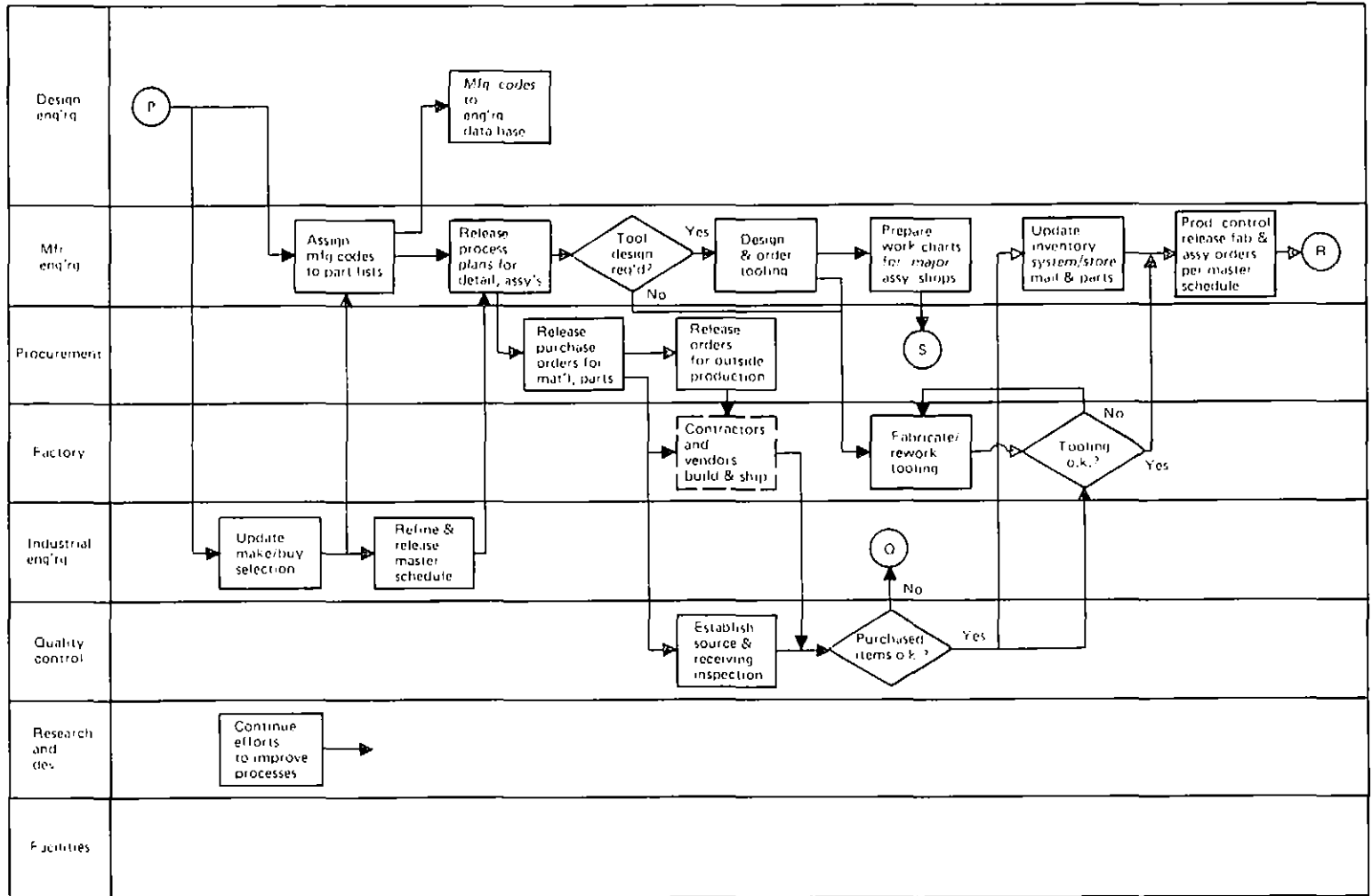

Figure 8.—Manufacturing Events Fabrication Phase

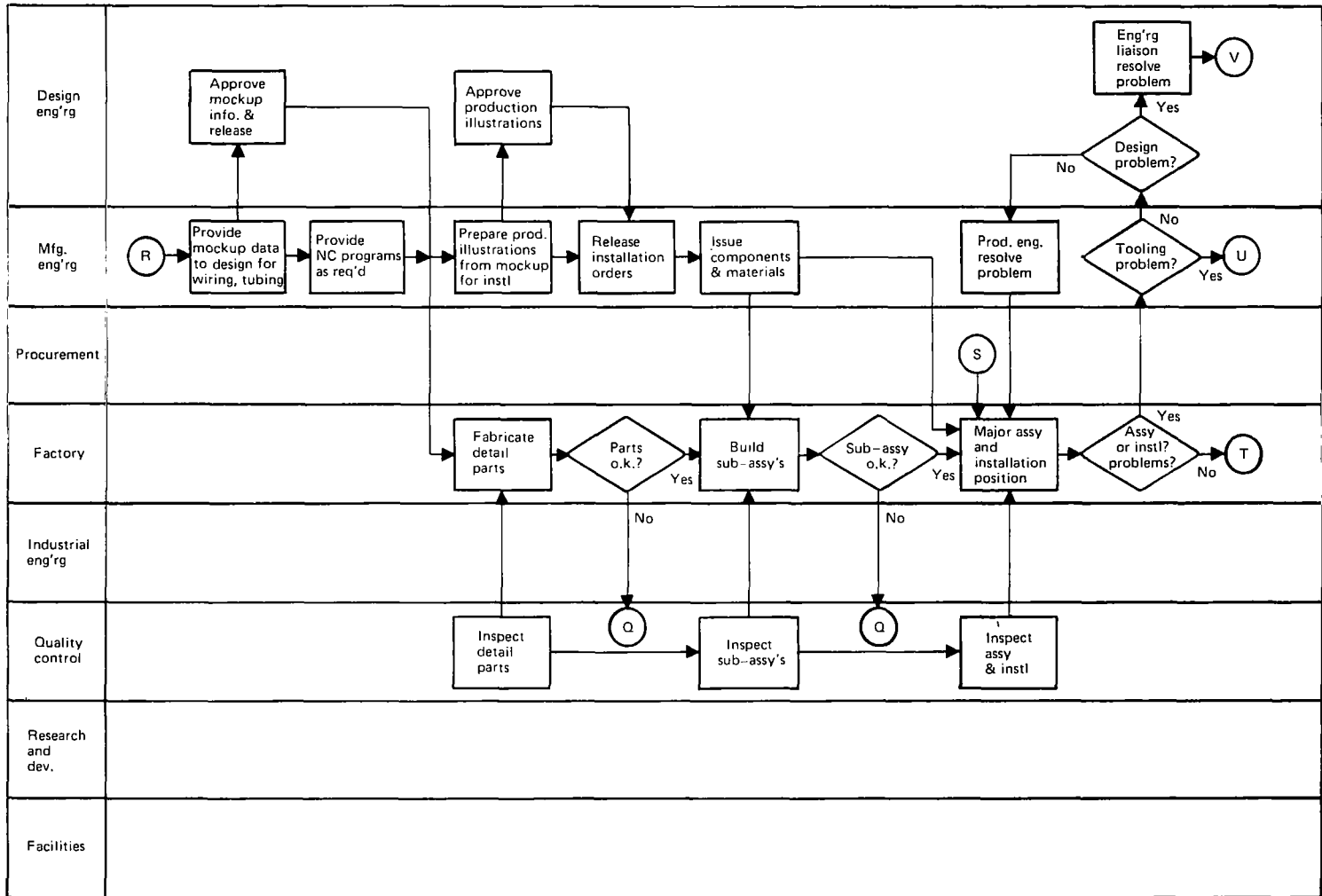

Figure 8.—Manufacturing Events Fabrication Phase (Continued)

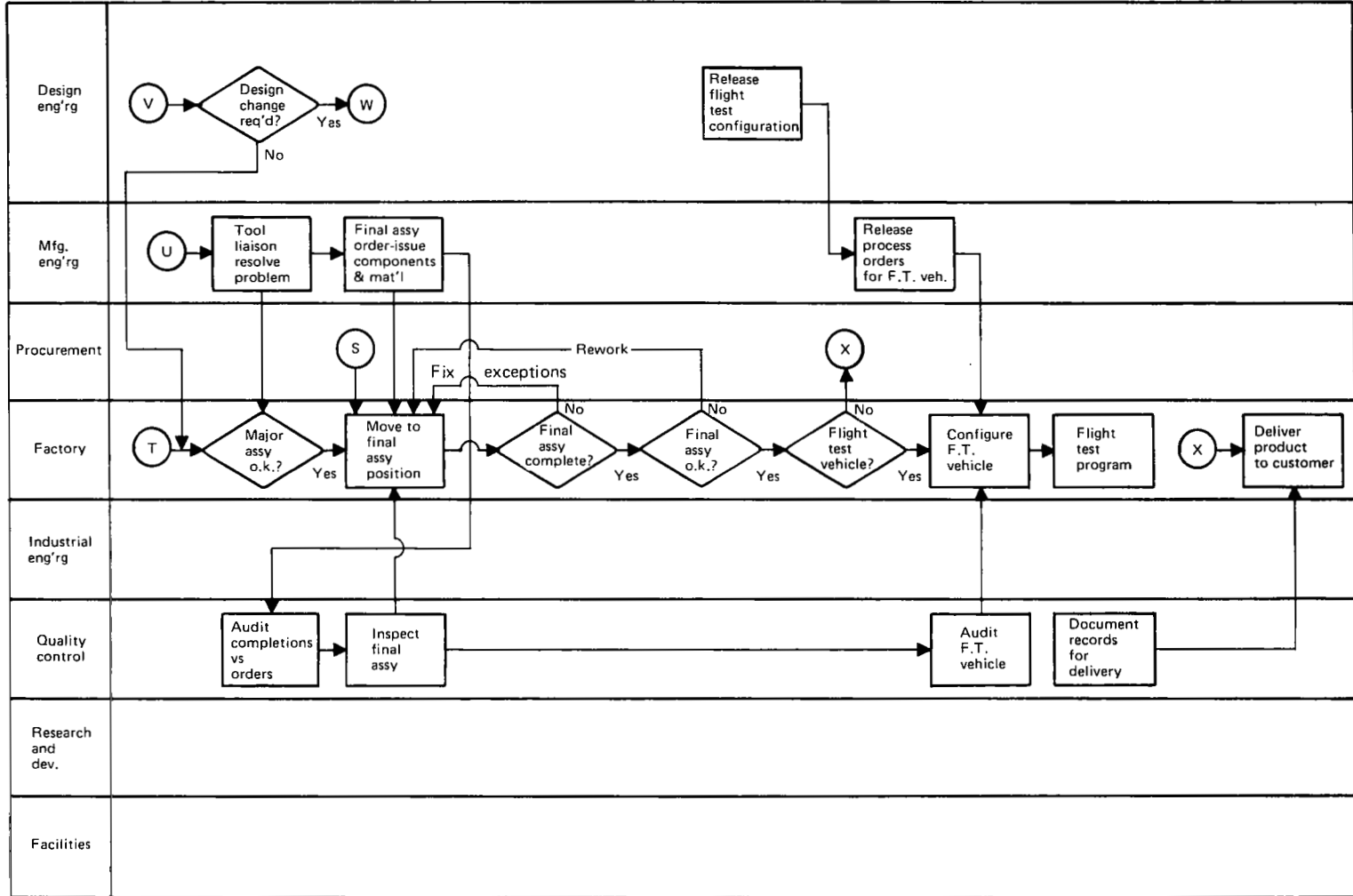

Figure 8.—Manufacturing Events Fabrication Phase (Continued)

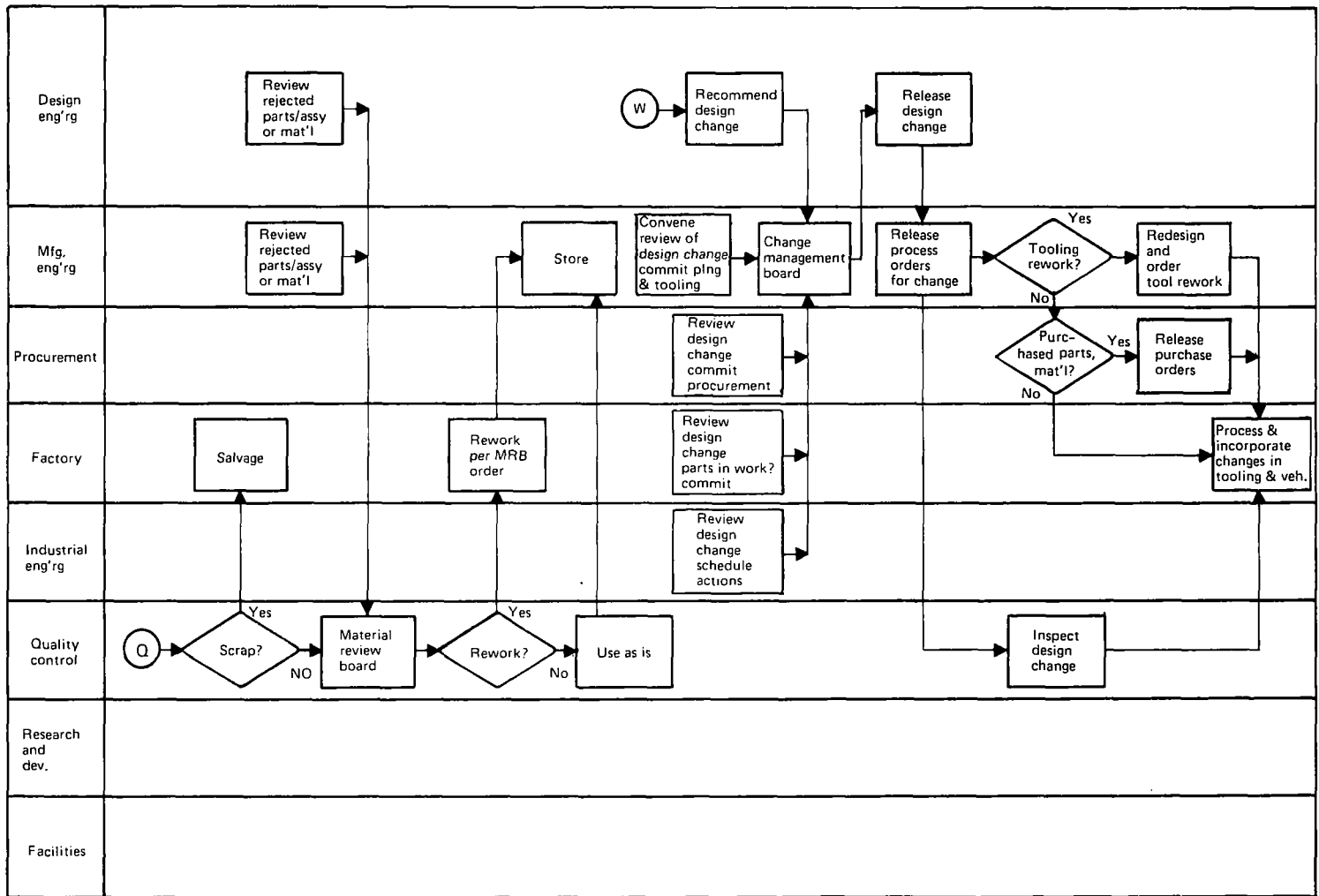

Figure 8.—Manufacturing Events Fabrication Phase (Concluded)

Table 1.--Information Required for Each Part

Item	Assigned By
Part number & name	Engr.
Used on part number	Engr.
Quantity used	Engr.
WBS number	Engr.
WBS description	Engr.
System identification	Engr.
Models used on	Engr.
Customers used on	Engr.
Preliminary release identification	Engr.
Change identification	Engr.
Replaces number	Engr.
Replaced by	Engr.
Notation of new or old release	Engr.
Reference to initial release	Engr.
Classification code	Engr.
Part size	Engr.
Material specification & options	Engr.
Material size & finish	Engr./prod. engr.
Procurement code	Prod. engr.
Schedule code	IE/PE
Part weight	Engr.
Material classification	Mat'l.
Material code	Mat'l.
Tool Requirements	Tooling
Quality requirements	Quality
Planning exceptions	Prod. engr.
Source availability	Mat'l.
Vendor identification number	Mat'l.
Procurement lead time	Mat'l.
initial	
reorder for in-production	
reorder for out of production	
Cost per part (recurring	Mat'l./fin.
and nonrecurring	
estimate	
target	
actual	
average	
Part cost per A/P.	System
as above	
Routing information	
receiving area	Mat'l.
inspection area	Qual.
storage	As responsible
usage	Prod. engr.
Budget and buyer code	Mat'l.

4.4.3 MAKE/BUY COMMITTEE ACTION

A special committee composed of manufacturing, industrial engineering, and quality control personnel meets periodically to decide whether components should be purchased or made in-house. Decisions are based on shop load forecasts, in-house manufacturing capabilities, and cost factors.

IPAD IMPACT

The immediate availability of design information shortens the decision making process of the make-or-buy committee. The 3D capability of the interactive graphics facilitates determining the total feature of each item under consideration by the committee.

4.4.4 MASTER SCHEDULE RELEASE

The master schedule developed in the detail design phase is refined, detailed for the fabrication phase, and released. It defines the basic production installation sequence and ensures the availability of parts and tools to support the production cycle. Every released order carries a using shop code. The schedule required to meet the demand of the part is applied to the order.

IPAD IMPACT:

Once developed, the master schedule is stored in the computer data base, where it is available to all organizations, either by viewing or by extraction from the computer on a printer.

4.4.5 MANUFACTURING PLAN RELEASE

The basic manufacturing plans developed for the detail design phase are refined. They are expanded to define the manufacturing processes needed to build the end product to satisfy the designed configuration. The manufacturing plan generally involves:

- Analyzing the engineering drawing for producibility

- Analyzing the potential methods and tools which can best be used to manufacture the part

- Determining the most economical method to produce the desired part according to the established schedule

- Releasing tool order and tool design requests for fabrication of tools required during the manufacturing cycle

- Determining optimum sequence for producing the part

Preparing a process plan to include part number identification, operation instruction, tooling requirements, and miscellaneous shop codes

IPAD IMPACT:

As a result of the continuous communication between manufacturing and design in the IPAD environment, most problems of producibility have already been resolved. Problems are still encountered during the fabrication phase; these are resolved by manufacturing interacting directly with the designer through the terminal.

4.4.6 MATERIAL ORDERING

Special equipment and materials are ordered as authorized by advance authorization release early in the detail design phase. Receipt of coded part cards authorizes the purchase of additional vendor items according to engineering document or drawing, or as specified on special orders received from manufacturing engineering.

IPAD IMPACT:

The present method of handwriting special orders and/or coding part cards for authorizing the purchase of material and special equipment are replaced by use of the display terminal. IPAD allows engineering to input to the data base the design requirements. Scheduling data and special coding are applied by manufacturing. The complete data are then available to Procurement through their display terminal or by output from a printer.

4.4.7 WORK CHART PREPARATION

Charts are prepared for use in assembly and installation areas which sequence jobs and operations in the most cost effective way. The charts are also used to indicate whether the area is behind or ahead of schedule. Charts and assembly planning paperwork complement each other.

4.4.8 TOOL ORDER RELEASE

Simple tools are ordered by manufacturing engineering directly from the tooling shops. More complicated tools require a special design. These are ordered from the tool design organization, which designs and orders special tools as instructed by production engineering. Tool orders are scheduled to meet demand dates of manufacturing.

4.4.9 IMPLEMENT PRODUCTION CONTROL PLAN

Production control is responsible for controlling the storage and issuance of materials and completed parts. Other functions include receiving, scheduling, disbursing, and clearing incoming action items; scheduling production orders; and posting production orders in the assembly shops.

4.4.10 COMPLETION OF MOCK-UP PLAN

Mock-up is responsible for building mock-up vehicles to support engineering space allocations and manufacturing system installations. Wire, tube, and cable routing is established and maintained through the fabrication phase. Drawings are drafted to show routing and hole locations for the attaching hardware in support of design changes. Feedback is made to engineering to update drawings.

IPAD IMPACT:

Physical mockups are eliminated or reduced in scope using the IPAD capabilities. The documentation for design changes is effected in the data base.

4.4.11 IMPLEMENT QUALITY CONTROL PLAN

Quality control is responsible for verifying that the manufactured product is in conformance with the engineering design. Changes to the configuration are also inspected and documented to assure configuration accountability with the design or contract.

IPAD IMPACT:

The graphic feature of IPAD makes it possible for quality control to extract from the approved display the information required to provide any special or unique inspection "tools" to support fabrication schedules.

4.4.12 IMPLEMENT LIAISON PLAN

Liaison between manufacturing and engineering is maintained at all stages of the manufacturing cycle. In addition, manufacturing has representatives in the engineering design areas to approve design changes from a manufacturing point of view. Continuous interaction is important between engineering and manufacturing in order to assure that product definition data is optimally utilized in its conversion to hardware.

IPAD IMPACT:

The interactive capability of IPAD assures a rapid response to design change requests from manufacturing. The system must be sufficiently flexible to provide manufacturing with the ability to change assembly components during and after the design phase by interacting directly with the design engineer.

4.4.13 DETAIL FABRICATION

The fabrication of details is accomplished by following a set of instructions as specified on a production order prepared by manufacturing. The order specifies the operations to be accomplished in sequential order, the tools required to fabricate the part, special inspections that must be accomplished, method of part marking, and finish requirements.

4.4.14 ASSEMBLY FABRICATION

The assembly process is governed by an assembly plan released by manufacturing. The plan outlines the sequence required to assemble the details in the most economical manner. Assembly tools are used, if required, to ensure conformity with the engineering drawing and proper fit on installation. Special instructions in the way of inspection requirements, finish requirements, and method of part numbering are also called out. Completed assemblies are routed to a production control area as noted on the plan. Work charts are also provided by industrial engineering in some assembly areas to further control the operations sequence.

4.4.15 COMPONENT INSTALLATION

The installation of details and assemblies is controlled by manufacturing engineering. Each plan is charted by industrial engineering to alleviate installation sequence problems. Shop personnel work from the chart to the job and make the installation according to the instruction on the job. Special tooling is

provided to aid in the installation process or where location or alignment of the component is critical.

4.4.16 CHANGE MANAGEMENT

A production change board consists of representatives from manufacturing, design engineering, materiel, quality control, program management, and factory. (Program management represents the customer's interests.) The board meets to evaluate and commit proposed engineering changes affecting manufacturing. Investigation is made by each representative, after which a commitment is made. A record is made of the commitment and copies are released to all affected organizations to authorize incorporation of the change in production and/or schedules.

IPAD IMPACT:

The availability of IPAD reduces the flowtime required to implement a design change.

4.4.17 MATERIAL REVIEW BOARD (MRB)

During detail fabrication and assembly operations, quality control finds discrepancies in the form of errors and departures from design specifications. This occurs both in-house and in the receiving inspection areas and can result either in immediate rejection of the item or a review by the material review board. The board is made up of design, manufacturing, and customer representatives and is chaired by quality control. Through visual inspection and by x-ray or other testing, a determination is made to reject or rework the item or use it as is.

IPAD IMPACT:

The MRB action can be expedited by using historical data available in the system. If the situation is new, the information will be added to the data base. Inventory accounts affected by the decision can be immediately updated.

4.4.18 FLIGHT TEST, ACCEPTANCE, AND DELIVERY

When applicable, one or more of the initial airplanes are assigned to the flight test program, which is used to check the airworthiness of the airplane, flight characteristics, and flight systems. These tests will be supported by reliability and safety assessments. Gauges and test equipment are temporarily installed to make the evaluation. Information obtained from the test program may generate changes to the production configuration, and these are referred to the change board and the customer for

evaluation and commitment. After completion of the test program, the airplane is generally returned to a production configuration for customer acceptance, certification, and delivery.

4.4.19 STATIC AND FATIGUE TEST PROGRAMS

Functional testing, static tests, and wind tunnel tests are pursued to provide engineering design with proof of design integrity and function. The continuation of such tests from the detail design phase is vital to improvement in the design, materials, processes, and manufacturing methods in order to produce a better product.

5.0 COMPUTER-AIDED MANUFACTURING (CAM)

This section describes the CAM systems that exist today and the interfaces with conventional, computer-aided design. The trends for CAM development are also discussed. It is not suggested that all of the CAM techniques and technology trends that are discussed will impact IPAD design or be supported by IPAD. Rather, this is presented as an overview to illustrate the potential boundaries of the support requirements. Section 6.0 describes the support requirements for the product manufacturing interfaces.

5.1 CAM TODAY

As in other sections of this document, a generalization regarding the norm in the aerospace industry has to be made. In this case it is to describe CAM as it exists today. In order to do this, commonly available systems will be described as well as systems that, while not widely used, are indicative of the state of the art.

Presently, CAD and CAM systems tend not to be integrated systems transmitting information to each other in an efficient, compatible language, but rather independent units isolated from each other. In order to illustrate how this is changing, CAD techniques and their output will be discussed briefly prior to reviewing CAM. (See figure 9 for an illustration of a CAD/CAM system.)

5.1.1 CAD SYSTEM OUTPUT

In order to be most beneficial, CAD output must be in a form easily used by CAM. Definition of parts, reference systems, and CAD geometric data should be defined in such a manner as to be easily manipulated (mirrored, rotated, transformed, etc.) by manufacturing. Programming of engineering part definitions for use by manufacturing is essential for economic use of CAD/CAM.

5.1.1.1 Interactive Computer Graphics (ICG)

Although ICG has been available since the early 1960's, it has only been since the early 1970's that the economic and technical possibilities have been realized.

ICG was initially conceived as a design tool, but it was soon realized that graphic display and manipulation of CAD data by planning, tool design, and quality control is desirable. The ability to satisfy common manufacturing problems is one of CAD's

capabilities. CAD's effective use depends on system to system interaction with CAM, otherwise the use of CAD/CAM will be diminished.

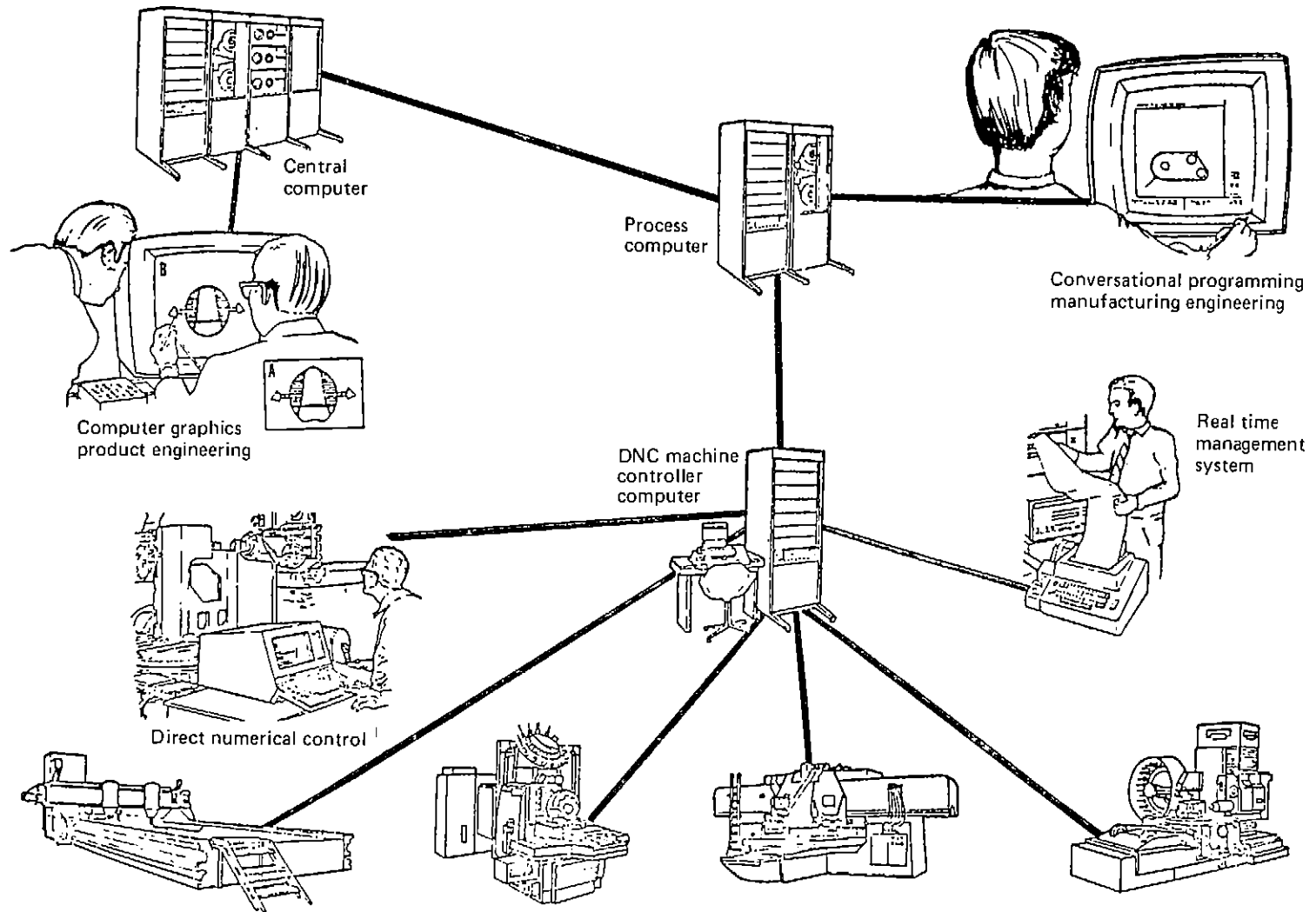

Figure 9.—CAD/CAM System

5.1.1.2 Part Definitions

In order for CAD data to be most useful to the manufacturing engineer, he should be able to retrieve desired data with minimal editing or conversion.

As the primary user of the geometric information presently is the NC programmer, the most practical way to store the data for manufacturing use is in the form of canonical statements defining the geometry of the parts.

This geometry may be translated from the IPAD geometry data base or may in certain cases (e.g., families of parts), be developed initially by design engineering, who utilizes the information for automatically drafting their designs. Geometry is then used directly by the numerical control (NC) programmers.

The geometry data base will provide support to design analysis, drawing, classification, process planning, NC programming, tool design, etc. Future applications may change and will vary between users. The ability to change the data base without difficulty and conform to new or changed circumstances is essential. Information has to flow freely between design and manufacturing to have an effective data base, for the data base will be both design- and manufacturing-oriented.

5.1.2 CAM SYSTEMS

The term CAM, has slightly different nuances to different people but is generally accepted as encompassing all aspects of planning and producing a manufactured part while utilizing computer equipment to assist in the manufacturing process.

Although some systems are common within a number of different organizations, an attempt has been made to categorize the systems into four functional areas of use: planning, tool design, NC programming, and fabrication.

5.1.2.1 Planning

Planning interacts with design at the beginning of a design program and develops as the program progresses. Computer-aided manufacturing for project planning, detail planning, and NC programming depends upon the closeness of this interaction to ensure that producibility is one of the prime considerations during the design process. Producibility of design, equipment evaluation, process method selection, and tooling requirements are all considered. CAM answers the question "Where do we go for fabrication, assembly, and installation; and what are the alternatives?"

Part breakdown and part control are also achieved by CAM. The planning of details and assemblies are considered. Assembly methods must be investigated in cooperation with engineering, quality control, tool design, and the production shop. New methods of assembly are determined to ensure maximum benefits from CAD/CAM and to avoid replanning details and assemblies when production has been authorized.

Computer-aided planning (CAP) (ref. 2) is "the interfacing of a computer system with the planning function whereby the computer either assists or performs all or part of one or several planning activities." Under this umbrella, it is difficult to imagine any but the smallest subcontractor lacking some form of CAP.

It is, however, the more sophisticated CAP systems that are generating much interest in both industry and Government agencies. These systems promise to automatically generate manufacturing plans and determine routing, tooling, feeds and speeds, etc., with minimum input. Progress in this area appears slow, primarily due to high cost. Generally, there is also a lack of group technology (part families) and "generative" process planning methods.

A description of computer-aided planning is listed below to indicate the norms of this activity in the aerospace industry.

Determination of Operation Sequence--This determination is accomplished with limited knowledge of past parts and/or process plans. It involves some use of "standard plans" concept on simple machined and sheet metal parts. Most machined parts and practically all assembly planning requiring intricate decision-making remain the sole province of the planner.

System Input (CAP System)--CAP involves extensive use of on-line devices such as teletype or alphanumeric cathode ray tube (CRT) to input data to computer systems. Planners or CRT terminal operators input through such devices in abbreviated form or code. (Input includes data such as length, material, etc., to facilitate operation time standards application by the computer system.) Ability to institute mass changes to any or specific classes of parts is essential.

Tool Order Creation--Tool orders remain primarily handwritten, i.e., not part of CAP system.

Tool standards (design and fabrication) are calculated or looked up in table by a planner or industrial engineer, and tool orders are scheduled manually.

System Output (CAP System)--Computer-expanded statements are output in detail planning form, and Computer-printed (device-

printed) planning is provided at the user's site. Operation time standards are automatically linked to production shop loading and performance measurement programs. CAP enables the user to obtain data on specific classes of parts.

General Features--The present system is not designed as part of a CAD/CAM system but was developed to solve specific problem.

Graphic systems providing manufacturing planning with geometric information are presently used by very few companies. These systems are being developed in conjunction with the alphanumeric system to facilitate communication between the design engineer and the manufacturing planning engineer.

Graphics will be used to break down assemblies and show details developed by CAD. Information developed by CAD is used in varying forms by CAM. Each transformation of information introduces chances for error and takes time. This cross feeding and integration of information in preliminary design and through design changes requires close interaction between design and manufacturing. Without this interaction time, money, and manpower will be wasted.

5.1.2.2 Tool Design

The major effect of computers in the tool design function is in the area of computer-aided graphics. Tool design uses the output of the CAD programming directly. Production part outlines, assemblies, and details are drawn. This reduces the effort required to obtain product design information by providing rapid access to a visual record of the part. By using as supporting tooling preprogrammed macros of commonly used tooling features and tooling standards, it is easy to build an image of the required tool design. CAD information plus tooling data are incorporated into tool designs for drafting tool drawings and graphical displays, and for NC programming of tools.

To ensure effective use of engineering geometry by tool design, the ability to edit and manipulate information on the engineering geometry must be simple and rapid, as tool design is one of the last operations prior to manufacture. Schedules must be met and tool design must react swiftly in order to meet the needs of the production shops.

Although computer-aided graphics are currently used by a few companies, they are by no means common. Before a tool design department can efficiently use these systems it is necessary that the airplane be defined in this manner. Before this can be done a strong commitment must be made by both design engineering and manufacturing. Although it is apparent that universal acceptance

of computer-aided graphics will come in time, the commitment to support this technology has not yet been made by the majority of the industry.

5.1.2.3 NC Programming

The NC programming area, with its development of programs enabling machine instructions to be produced, was one of the initial users of computers in manufacturing. It is still a major user of computer equipment in the aircraft industry, and in some areas, unfortunately, NC and CAM are considered synonymous.

The most common way of providing an NC machine control medium is still by having a programmer interpret the part geometry on the drawing and convert this to instructions acceptable to an NC machine. For simple parts, the programmer can write the instructions directly into machine-readable code. For more complex parts, high-level languages have been developed that enable a programmer to describe the part and how he wishes to machine it. This information is then utilized by the computer to produce the machine-tool-readable code.

With the introduction of automatic drafting machines capable of being driven using NC programming languages it became apparent that, in certain cases, the engineer could economically provide the NC programmer with geometry in a format he could use directly.

Using a common data base with design avoids the laborious method of having NC programmers study the engineering drawing and then define the part. Since this takes up much of the programmer's time, the cost saving is obvious. Also, the frequency of errors, duplication of effort, and program debugging can be decreased.

Interactive computer graphics in support of the NC programmer significantly reduces the effort involved in creating control instructions for NC equipment. Working from a common data base with engineering product design and tool design engineering, the need to interpret their geometric descriptions is reduced.

Normally, using a high-level language, the NC programmer writes a description of the cutting tool's motion (path) relative to selected geometric features of the part. The starting and ending position of each path must be described with the symbolic names of the part feature as well as the cutter's relation to those entities (to, past, on) and the direction of motion such as left, right or forward. A sequential series of these statements will describe a path of the cutting tool as it moves in, out, and around the part without violating desired features of the completed part geometry. The programmer must calculate and add to these motion statements the required feed and speed values

providing optimum metal removal rates and creating acceptable surface finish.

With interactive computer graphics, the programmer uses the automatic motion-generating routines provided to create the cutter paths and provide a computer language source code describing the paths.

Unfortunately, the systems presently available on the market are limited in their capability, being able only to program two-and-one-half-axis NC equipment. (There are proprietary systems that are more advanced). The minimum requirement is to support five-axis NC equipment.

This is a relatively new application of computer graphics, and improved system performance is expected, based on total commitment by manufacturing and engineering.

The IPAD data base should be capable of completing geometry for drafting and NC programming. This common data base will provide communication between design, drafting, tooling, and NC processing.

5.1.2.4 Fabrication

When people discuss CAM there is immediate association with NC machines. This connection is obvious, but until the recent advent of CNC and NC systems (see below), there was no computer use at the factory level. The only tie was that the NC machines used punched tape produced by a computer. This condition changed, however, as DNC systems were introduced, tying the distributive computing system directly to the NC machine controllers or, in the case of the CNC system, actually replacing hard-wired NC controllers with minicomputer-based, soft-wired controllers. In addition to the application of computers for NC, the use of computers for the storage and handling of parts and tools is presently receiving some attention, although these techniques are still in their infancy.

Distributed Numerical Control (DNC) and Computerized Numerical Control (CNC)--The Electronic Industries Association (EIA) has recently compiled a revised glossary of automation and numerical control terms. It includes:

DNC--A system connecting a set of numerically controlled machines to a common memory for part-program or machine-program storage with provision for on-demand distribution of data to be machined. Typically, additional provisions for collection, display, or editing of part-programs, operator instructions, or data related to the NC process are provided.

CNC--An NC system where a dedicated stored-program computer is used to perform some or all of the basic NC functions in accordance with control programs stored in the read-write memory of the computer.

Soft-Wired Numerical Control--Another popular term for CNC

Although most members of the aerospace industry have some form of DNC or CNC, a recent survey (ref. 3) indicated that the majority of AIA member companies are "actively investigating systems that are on the market." The reason it is possible for industry to have some form of CNC/DNC and still be interested in further equipment is because the field is rapidly changing due to innovations in minicomputers, software, and other hardware.

Adaptive Control (AC)--The term adaptive control, when used by manufacturing engineers, refers to the automatic adjustment of the rate of feed and speed of the cutter, drill, grinding wheel, etc., in a metal removal operation. (See figure 10.)

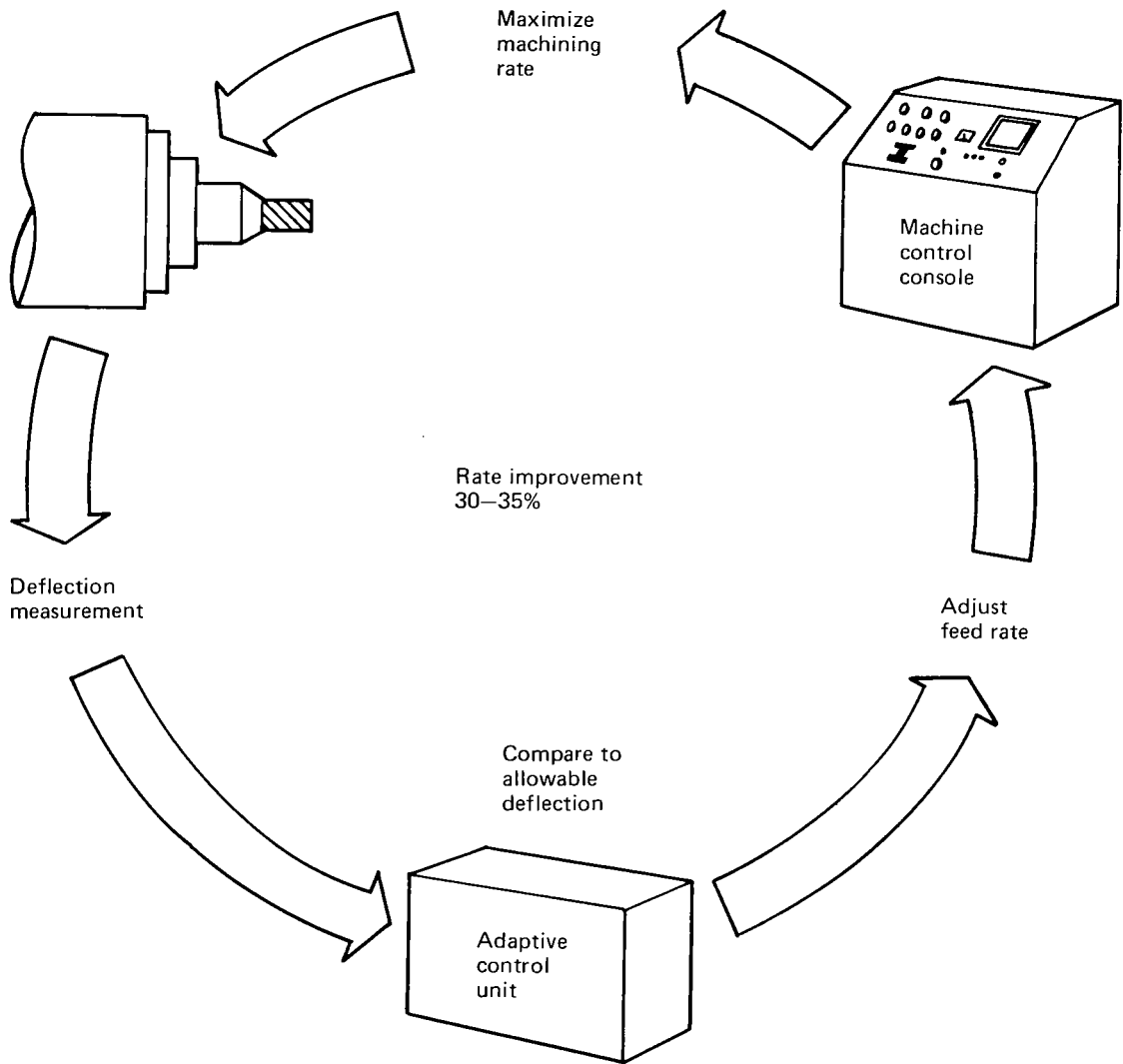

Figure 10.—Adaptive Control (Early Version)

Numerous methods have been tried in order to develop an effective control method, but only in the area of milling has any measurable success been attained. In this operation the most widely used methods of AC are a) the deflection measured at the spindle and b) determining how much horsepower is being used. The development of adaptive control is still in its early stages, and its application is presently limited.

5.1.2.5 Quality Control Interface

The quality control (QC) department is responsible for assuring that the finished product conforms to the engineering design and that a system of historical records is maintained to identify actions taken to produce the product, including objective evidence of work performed.

Historically, QC has been a post-process function. The increased use of the computer has impacted the QC department not so much by their increased use in that area but by their use upstream, which has resulted in parts being produced more consistently, with greater accuracy and fewer errors.

Common geometry used by engineering and manufacturing help ensure that information exchange is accurate and parts are planned and programmed according to the drawing. The NC machine, adaptive control, and in-process inspection devices all help to ensure that the product hardware is produced according to design.

Although these applications of the computer are related to the quality of the product, they are all areas outside the assigned role of the quality control organization. (The QC organization does have the responsibility of assuring the integrity of the information upon request by engineering and manufacturing.)

The application of the computer by or for the QC organization has largely consisted of specialized NC equipment, programmed by the QC people to verify dimensional correctness of parts. Also, equipment that automatically tests the functions of electronic equipment, verifies diagnoses, and isolates faults is widely used.

As in-process verification and feedback control become more sophisticated and parts are checked against data base requirements, with corrections made while still on the machine, the post-processing inspection requirement will be reduced. The quality control function will, therefore, move more towards the certification of the processes themselves, using the postprocess inspection as a supplemental assurance of in-process verification and process control. In order to support this new role, present statistical methods will be further developed to provide a comprehensive source of statistical and historical information regarding both processes and parts.

5.1.2.6 Loading and Scheduling

An industry survey was recently completed to determine the state of the art of implemented and planned computerized systems, techniques, and procedures for machine loading and scheduling (ref. 4). The following is a pertinent passage from the reference 4 survey:

"Applications reported on in the questionnaire response strongly indicate that the great majority are over five years old and that one-third are ten years or more old. These older applications are more or less standalone applications and not of an information network nature, do not operate in real time, may have poor capability for response to changes in day-to-day operations. Since these are all 'current systems', they complement each company's 'way of doing business.' Each system was developed to automate functions in a company subdivision, or department, and are not integrated in nature. Communications between departments or activities, which exist, are usually procedural rather than automated. This creates a situation where any significant changes, especially to integrate into a network system, must be identified as long range and supported by a comprehensive plan. For the near term, the solution is some updating, but the tendency is to create heavy fiscal and political resistance to large change, even though these systems probably can be considered as having more than paid for themselves and their continuance may be relatively costly compared to a modern version."

5.2 TRENDS IN MANUFACTURING TECHNOLOGY

One of the major problems in predicting trends in the aerospace industry is that it comprises such a large number of corporations and products and such a diversity of technical disciplines that any prediction can only be of a generalized nature. As IPAD is intended to support the aerospace industry as a whole, it will be necessary to develop a forecast of manufacturing as it might exist in the 1980's.

The areas to be discussed in this section will cover: a) the changes in manufacturing technology, detailing new manufacturing processes, and b) the developments in manufacturing systems that are leading towards computer-controlled flexible automation.

5.2.1 CHANGING MANUFACTURING TECHNIQUES

Although new materials and processes will be developed and utilized in the future, there is no reason to believe that they cannot be accommodated by an integrated system as proposed by IPAD

and as forecast for the manufacturing area. In fact, the more the materials and processes change, the greater is the need for a system that will keep the design engineer up to date on current capabilities and requirements in the manufacturing area. In order for the scenario of manufacturing in the 1980's to be complete, a brief description of changing manufacturing technologies has been included.

5.2.1.1 Decreased Chip Making

Anticipated future changes in metalworking processes, for example, include a definite movement toward metal forming and metal synthesis rather than metal removal. More pieces will be stamped, cast, formed by powdered metallurgy, or formed by newer techniques of metal part synthesis. Other techniques such as laser cutting, improved NC welding, NC grinding, electro-chemical machining, and automated bonding processes may also become common metal processing methods.

Castings and Forgings--Research and developments are taking place to enable castings and forgings to be made to extremely close tolerances, so that parts will be net size or will require minimum metal removal.

Powder Metallurgy--New technologies like powder metallurgy, which uses injection molding with powdered metal, are making advances due to their potential for producing thin-walled parts more economically than by casting.

Grinding--Changing aerospace designs require that in areas where metal continues to be used, higher-strength material and closer tolerances will be called for. It has been forecast that the use of the grinding process, which satisfies both of these requirements, will continue to increase, and research is being devoted to improvements in this area. Emphasis is being given to abrasive machining systems that can outperform conventional milling for high-speed metal removal.

Special Metal Removal Techniques--Due to increasing hardness in materials used in aerospace components, several techniques have emerged that will become increasingly common. Examples of these are electrical discharge machining, electrochemical machining, and laser beam cutting.

5.2.1.2 New Materials

Not only will manufacturing operations change to take account of decreased metal removal techniques, but we can also expect increased use to be made of plastics and composites in new product designs. Although limited use has been made of bonded structure, particularly in the manufacture of fighter aircraft, the use of this technique in major structures has been avoided. Additional research is required in this area, but cost and weight advantages of this technique indicate that its use will expand rapidly.

The predictions below, quoted from reference 5, indicate that a rapid increase in use of composites can be expected in aircraft.

"The McDonnell Douglas F-15 fighter contains 225 lb. of carbon and boron composites, and George P. Peterson, director of the Air Force Materials Laboratory at Wright-Patterson Air Force Base in Ohio, believes that by the early 1980s the Air Force may have a fighter with a structure that is 50% composite. By the 1990s, predicts Robert L. Vaughn, an engineering program manager for Lockheed-California Co., "about 70% to 80% of the structural weight of a commercial airplane will be made of advanced composites."

The increased use of plastics and composites has the effect of replacing built-up sheet metal assemblies with single (or few) parts for which digital definitions are required. The initial impact may be slight, but the combination with NC sheet-metal centers will result in a large increase in digital definitions in the IPAD data base.

5.2.2 CHANGING COMPUTING CAPABILITIES

Except for business systems, the use of computers in manufacturing has until recently been primarily in the control of individual processes. The integration of these processes and the closer tie with the design function are directions now emerging. This, it is felt, will provide major benefits in the producibility of parts being designed and in the management of operations.

The majority of computers used in the control or automation of production, quality control, and process monitoring in the aerospace industry are minicomputers. It has become evident that the new small computers have as much or more available capacity than did some of the early large computers, but at a much lower price. Also, systems based on minicomputers are relatively simple in comparison to the very large, multifunction systems. Minicomputers permit the development of systems to satisfy requirements as they arise instead of having to find a sufficient number of applications to justify a large- or medium-scale

computer. It is the continuation of the trend toward lower computer hardware costs and the hierarchic approach to designing systems that will provide the means for fully utilizing the computers capability in manufacturing.

5.2.2.1 Computer Hardware

The change in computer hardware that over the past 15 years has resulted in the reduction in cost and correspondingly wider use. The increase in the number of components on an integrated circuit (IC) chip has not only led to a proportional decrease in cost but also to an increase in reliability. This trend, along with its associated benefits, is expected to continue at least for the next five years. David A. Hodges has stated (in "Trends in Computer Hardware," Computer Design, February 1976) that "by the early 1980s, it is possible to visualize the existence of a complete minicomputer system on a chip, including a 16 bit CPU, 32 kilobits of read-only and/or read/write memory, and simple input/output (I/O) interfaces. Speed, as limited by power consumption and serialized I/O, might be in the range of 100,000 to 1,000,000 instructions; manufacturing cost should be \$10 or less." It is this low cost and improved reliability that will ensure the continued growth of computer usage in manufacturing industries.

Along with improvements in the central processing unit comes a reduction in cost of fast-access/storage devices. These changes, as well as the increasing cost of telephone connections, come into the decision regarding computer architecture. They point the way to multiterminal systems, each maximizing internal information processing and storage to minimize communication with the central computer, the central computer being used only for shared data bases.

5.2.2.2 Hierarchic System

Although large-scale computers are used to drive a large number of control systems, it is generally believed that dependence on a centrally located computer is unwieldy and uneconomical. With this type of system the whole plant is dependent on the computer being operative which often makes a backup system necessary.

The development of minicomputers has changed this concept, and the benefit of a hierarchic approach has been appreciated. Beside the ability to develop portions of a system one piece at a time as the need arises, the total system is not so concerned with the failure of one of the several minicomputers, as only a small portion of the plants capacity would be affected. Also, if

similar hardware was being used, an extra backup unit could be held in support of any of the several units.

Minis are capable of carrying out many processing activities and can at intervals transmit or receive data at a higher-level central system. This is a form of problem distribution whereby each level of the hierarchy has the ability to develop a solution for that problem.

The multiple processor systems are gaining popularity in manufacturing, as large numbers of industrial processes are relatively independent. A hierarchy can, however, be formed by integrating the processes with links that allow the tasks to be coordinated and scheduled; or it may pass any other type of data to a central computer.

Computer Numerical Control (CNC) ----CNC is defined as "an NC system where a dedicated stored program computer is used to perform some or all of the basic NC functions in accordance with control programs stored in the read-write memory of the computer." This type of system, also known as soft-wired control, became economically viable in the early 1970's.

The initial CNC systems merely duplicated the traditional capabilities of hard-wired NC plus having the capability of buffer storage. This relatively simple extension improved tape reader reliability because of fewer starts and stops. Additional extensions in storage enable cutter length and diameter changes to be accommodated and allow axis error calibration to be accounted for in software. Soft-wired controllers have also been developed to enable CRT displays and on-the-floor editing of machine control data and to provide specialized test and diagnostic routines, permitting the identification and isolation of any control malfunction.

It is apparent that minicomputers will continue to increase in usage in control systems, not only due to their improving competitive price but also because the potential features of computerized NC will be exploited. Tasks will become more complex and better suited to their speed. The minicomputer will not merely take over tasks that can be performed by a conventional hard-wired controller; it will carry out such tasks as integrating part programming, complex adaptive control, machining optimization, or data communication management. Thus, a CNC system can include mass storage peripherals that store a library of part programs; integrate with a larger management information system from which it can retrieve programs as required; or store data that it has monitored regarding piece count, malfunction alert, downtime, and any other system performance parameters.

Distributed Numerical Control (DNC)--DNC is a system connecting a number of numerically controlled machines to a central computing system with sufficient memory for machine program storage with provision for real-time access and distribution of data as requested by the NC machines. This type of system, presently implemented in some of the larger companies, is one of the most "visible" steps in the hierarchy toward a fully integrated manufacturing system.

5.2.2.3 Software

As the cost of computer hardware continues to fall, the importance of developing supporting software plays an increasingly dominant role in the economics when trying to justify computers in manufacturing. It is these software costs that are giving impetus to the cooperation of companies in developments in these areas. Various Government bodies have also seen the benefits and necessity of this cooperation and have, in certain instances, provided additional incentives for industry to cooperate in these developments.

Manufacturing Information Systems--Manufacturing information systems will be developed that will tie all manufacturing files and reference tables together into a data base. These systems will be designed to enable a wide range of users to interact with a common integrated data base. Users will access this data through terminal devices in a manner that will enable them to retrieve data by explicitly defining their requirements or indirectly by using an implicit relationship.

At present, manufacturing information systems are alpha-numerically oriented services, with limited use being made of graphic information. In order to ensure better use of all the data that will be available, it will be necessary for the user to easily comprehend the information presented to him. This may be achieved by showing the information as text, tables, networks, bar charts, graphs, or diagrams; in some instances, the information may be animated. The form that this output would take would be determined by the system, which would select the structure that is easiest to comprehend.

This data base will be constantly updated and utilized and will comprise of the following types of data:

Parts and product information--geometry, specifications, codes, cost, hierarchic arrangement

Purchased material information--vendors, vendor catalogue, codes, addresses, types of parts, open orders, prices

Plant facilities--fixed equipment and utilities, trucks, cranes, etc., and their moving and carrying ability

Routing and operations--standard plans, codes, machines, tools, and related standard times and costs

NC operations--machines, tools

Parts and order status--in-work, stored, behind schedule

Cutting tools--cutters, codes, material, feed, speed

Material characteristics--cutting feeds, speeds, cutting fluids

These are some of the many files that will be stored in a manner that will enable it to be most easily extracted and in a format designed for its intended use. As a result of this capability, coordinated current information is available to all users of the system at all times. This will enable the manufacturing organization to respond more quickly and with less chance of error than before.

Automated Planning--These systems are initially expected to aid planning by retrieving plans similar to those required using a classification code. This "standard plan" may then be modified to the unique configuration required. It is, however, envisaged that this type of system will be developed to have decision capability based on design output. Features would include automatic calculation of feeds, speeds, cutter selection, and standard time data.

Improved NC Language--Major improvements in NC languages will be adopted in the form of languages that utilize geometric information and also considers material and cutter information. With these systems, we approach the fully automated NC program whereby information from the design engineer can be translated into an NC program with only the minimum of manufacturing intervention.

EXAPT--The EXAPT program (an extension of APT) takes into account not only geometry but also optimal cutting conditions, manufacturing and tool sequence, tool selection from libraries of standard preset tools, collision computation, division of cuts (based on the calculation of suitable speeds and feeds and depth of cut in view of the constraints arising out of available power), maximum permissible surface roughness, and properties of the work material.

Although EXAPT appears to be more advanced than APT, it is limited by the volume of geometric and technological information that it has to process. Therefore, EXAPT is appropriate for work up to 2-1/2 axes, but for more sophisticated multi-axis programming, APT is the only suitable language. Although EXAPT is the most widely known of the extended APT programming languages, development is continuing on other languages that promise similar benefits.

Special Computer Software--One good example of special capability was developed at Battelle Columbus Laboratories for designing and analyzing the forging process. Using an interactive graphics system and the "FORCE" computer programs, a designer is able to observe a simulated disclosing which permit metal flaw and stress conditions to be seen. Modifications can be made to the die design and the results of the change viewed.

Minibased Graphics--Several minicomputer-based interactive graphic systems have appeared on the market that are presently being used in support of both design and manufacturing operations. Some of these are "turn-key" systems that provide a complete software/hardware package. Other suppliers offer the software for such a system. These have been used to develop printed circuit boards and more recently have been applied to product design, tool design, NC tape generation and verification, and quality assurance. Some of these systems offer 3-D graphics capability. They can be used as a stand-alone, a satellite station (connected to a larger system), or part of a distributed system.

5.2.3 NEW CAM TECHNIQUES

This section discusses new CAM techniques that are still in their infancy but are generally accepted as systems applicable throughout the aerospace industry.

The reasons behind the ability to justify these systems--and the technologies involved--have been mentioned in sections 5.2.2.1, 5.2.2.2, and 5.2.2.3. This section will outline the application of computers in manufacturing.

5.2.3.1 Graphics

The economics of utilizing numerical drafting techniques are very poor when one tries to justify such techniques on the basis of providing a drawing alone. This is due to the fact that the drafting operation is simply replaced by a programming operation. Improvements can be achieved by providing macros for common items or by writing master programs that can be easily modified to

generate a large family of parts. However, computer graphics has its real potential when integrated into a manufacturing system where most, if not all parts are numerically defined, so that numerical control can make direct use of this data.

The three major facets of manufacturing engineering--NC programming, tool design, and manufacturing planning--are expected to make use of interactive graphics.

Interactive graphics provide a significant opportunity to increase the overall productivity of the tool engineering functions through the use of automated design, drafting, and NC programming. Utilizing a CRT to extract engineering/manufacturing part definitions and previously defined macros from a data base, a picture of the required tool can be quickly formed. This information can then be used to produce a drawing automatically; also, the geometric definition may be used directly by NC programming.

NC programming will utilize computer graphics to achieve significant reductions in the effort required to create control instructions for NC equipment by using a CRT to interrogate the data base. Both part and tool descriptions defined by engineering and tool engineering may be obtained. The programmer will then create additional geometry to satisfy machining requirements prior to creating cutter paths.

The manufacturing planner will use computer graphics to display, interpret, and manipulate design data. It will also be possible to copy the engineering data file, which may then be manipulated as necessary to reflect the manufacturing plan. This information will then be conveyed by CRT display or hardcopy output to the downstream organizations.

Even with the increased use of CRT displays in manufacturing engineering and the obvious applicability to distributed manufacturing systems, it is difficult to imagine the hardcopy design drawings disappearing totally from the shop floor, whether prepared manually or from computerized data.

5.2.3.2 Material Handling and Storage

This is a subject area in which it is difficult to forecast future developments as it is known that these types of systems are already operational. It is easy, however, to imagine these systems being more fully utilized. Although the potential for application of automated material-handling systems in the aircraft industry may not be as extensive as in mass production industries, the improved flexibility offered by programmable material handling systems will enable them to be more widely used in the integration of manufacturing systems.

These material handling systems would best be utilized to support manufacturing shops that are organized to fit the group technology "family of parts" (see section 5.2.4) concept. The manufacturing areas would be divided into sections, each of which produces a specific family of parts and employs a specific method of material handling.

Groups of machines within a particular work area would be located within reach of a robot transfer device so that they could be loaded from a conveyor which would supply the shop from an automated storage area. These storage areas would be used for storing and retrieving materials, parts, and tooling and keeping track of all movements within the buffer storage system. The material, part, or tool to be stored has initially to be identified and entered into the computer's inventory. The part will then be optimally positioned for retrieval within a large storage area by use of automatic conveyors, stacker cranes, etc. The position of the item is recorded by computer so that it may be retrieved at a later date. The buffer storage devices could then automatically issue parts and material to the area material handling system in order to load the shop according to optimized shop loading programs.

The material handling systems would also include the reporting of material, part, and tool location throughout the manufacturing areas. The movement of materials through the area could initially be tracked through manual inputs from shop terminals but could be further automated through the use of sensing devices. In order to be even closer to a fully automatic system, the material handling system and direct numerical control systems would be integrated, thus facilitating the manufacture of a part by transferring and machining parts at sequential work stations.

5.2.3.3 Robotics

In the previous section, reference was made to the use of robot transfer devices. In the material handling system suggested the robots would most likely be relatively unsophisticated. In the area of automatic assembly, robotic devices are being developed with a degree of complexity directly related to the need for sensing devices and number of axes of motion. However, robotics have not yet found a wide range of tasks within the aerospace industry for which they can be economically justified. Two factors that are expected to make the use of robots more widespread in the future are: a) reduced price of microprocessors; and b) the development of tactile and visual sensors that will enable the machine to adapt its task based on its environment. Applications of these developments are listed below:

Automated Visual Sensing--The ability to identify a part and determine its orientation and position is being developed for use in robotic systems for sorting and positioning parts for assembly.

Visual Inspection--Compares a part with its stored image in order to verify completeness and correctness or detect flaws and damage.

Tactile Sensing--Sensors are incorporated in manipulators to enable forces and torques to be measured. This feedback mechanism could be utilized in assembly robots.

5.2.3.4 Adaptive Control

Modern production systems are becoming more complex due to the increased complexity of parts manufactured and the demand for higher dimensional accuracy and better surface finish of the parts. The method by which these systems may be effectively optimized will depend on the ability of research engineers to develop new concepts of adaptive control. The tasks of designing an adaptive control system and determining the setting of the system's optimum operational condition are extremely important problems yet to be solved.

Optimization of the various manufacturing processes that comprise a production system requires a clear understanding of the process to enable effective control systems to be utilized. Based on the advances being made in disciplines such as information and communication theory, control systems, probability and random process theory, and with the power and versatility of the computer, it is thought that models identifying the characteristics of each manufacturing process can be developed. This will enable the performance of the system to be described quantitatively, thus enabling optimization to be achieved.

5.2.3.5 Further Examples

Additional examples of how the computer is impacting the area of manufacturing is illustrated below.

Sheet Metal Center

Sheet metal fabrication has not had a major technical breakthrough in fabrication of parts from sheet stock in over thirty years. The standard practice is still that of multiple handling with only one operation performed at each station. The computer now makes possible a new approach, that of enabling multiple operations to be performed with automatic handling between, and positioning at, sequential

sheet metal operations. (See figure 11.) The Air Force ICAM program is studying this capability.

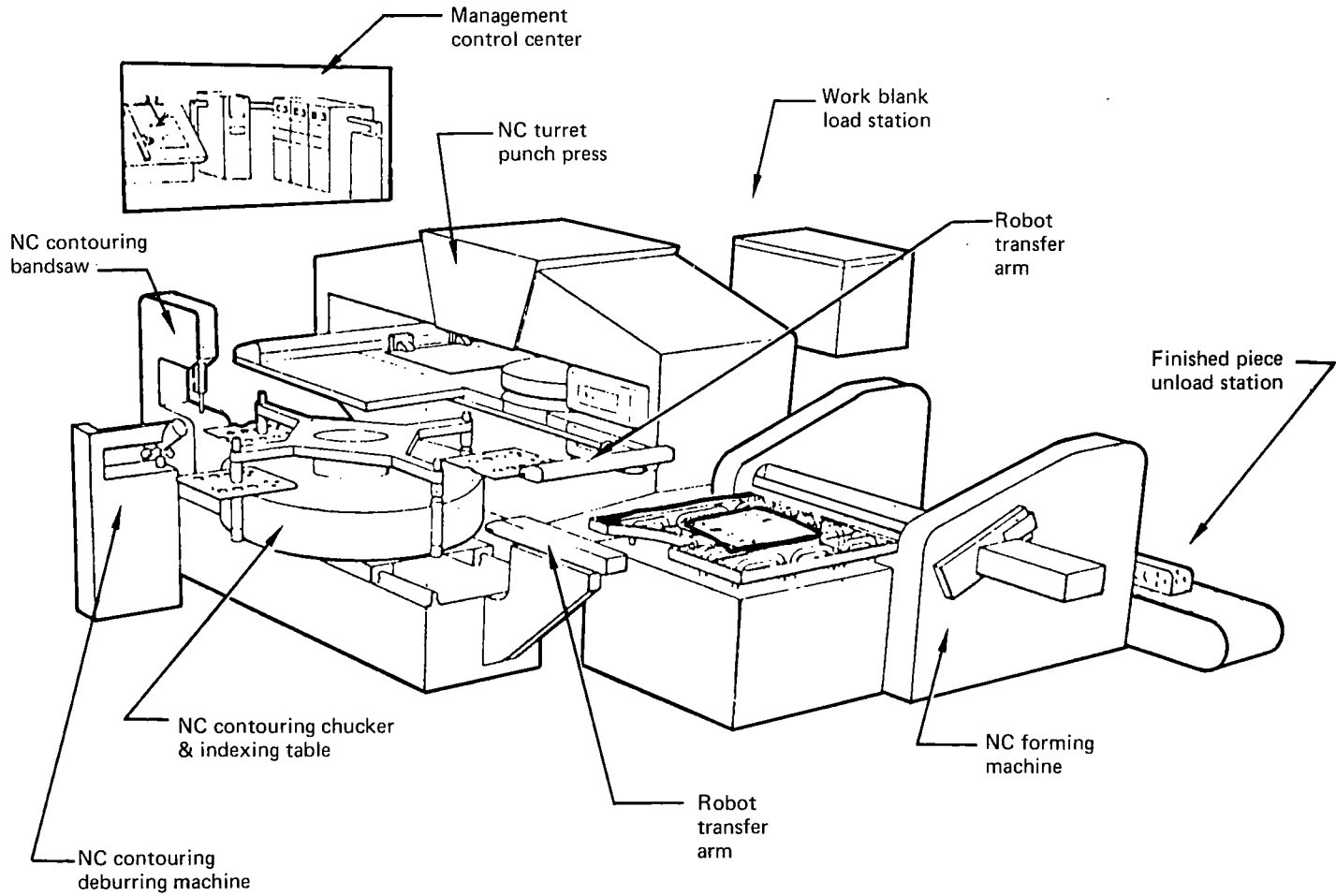

Figure 11.—Sheet Metal Center

Roll Forming

Advances in NC in the sheet metal area is also visible in the development of numerically controlled roll application enabling certain stringers, frames, spars, and ribs to be formed. (See figure 12.) Additional developments are planned to extend the equipment's capability to allow variable angle sections and variable section height to be processed.

5.2.4 CLASSIFICATION AND CODING

Classification and coding is a method by which numbers or letters are arbitrarily assigned to specific geometric or function attributes. When similar items are coded according to these attributes the parts can be grouped into classes identified by a code.

Many different systems have been designed for classifying different types and categories of parts. This permits the code to be quite short but limits its usefulness. Unfortunately, the more nearly universal a code is, the more difficult and expensive it is to use. Therefore, systems presently in use tend to be a compromise between these two extremes.

Engineering design has implemented coding systems in order that duplicate or near duplicate parts will not be redesigned, thus saving costs in both engineering and manufacturing. Codes developed for grouping processes and/or routines are still in their infancy in the aerospace industry but promise benefits:

- The ability to retrieve and generate manufacturing plans using standard operation instructions based on proven manufacturing practices

- The ability to find and select existing tooling for new parts

- Reduced set-up times between similar batches when scheduled in sequence

- Optimum grouping of manufacturing equipment

- The ability to estimate the cost of new parts based on stored data with similar codes

- Make/buy decision made on families of parts

- Justification of specialized equipment

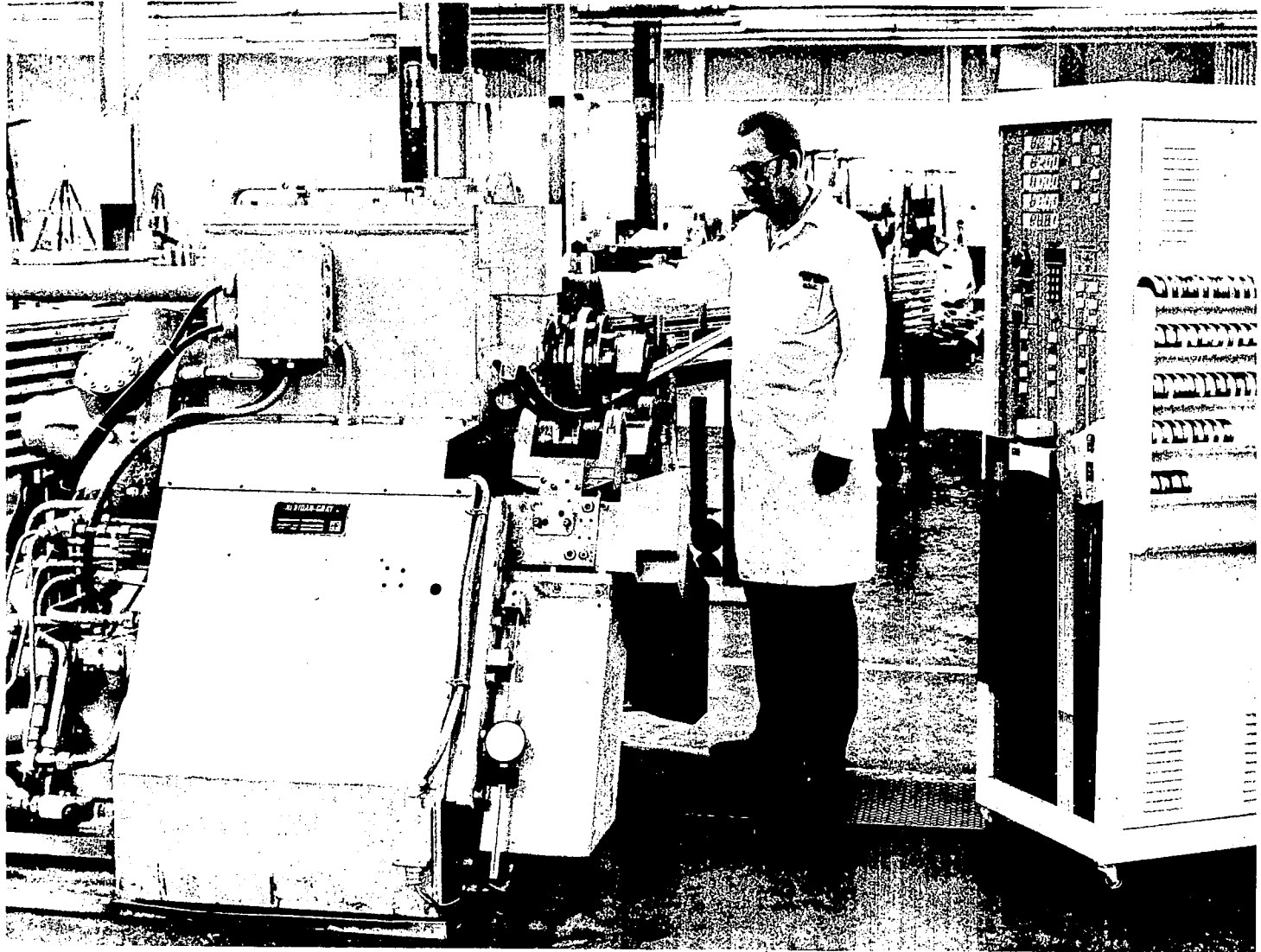

Figure 12.—Roll Forming

When fully implemented, the classification and coding (C&C) system is used by designers and draftsmen in the design environment and by manufacturing and industrial engineers in the manufacturing operations. (See fig. 13.) An integrated system such as IPAD can greatly enhance the benefits of the C&C system without impacting IPAD. The code is merely one element assigned to a part (see fig. 14) and in some companies is replacing the part number (see section 6.3.5). The ICAM Air Force program includes the development of a plan for a classification and coding system. Figure 15 illustrates the potential scope of a C&C system.

5.2.5 QUALITY ASSURANCE

New technology and trends in quality assurance are discussed below.

5.2.5.1 Image Analysis

This is a technique referred to as "artificial intelligence" whereby automatic visual inspection is utilized to check parts for conformance to requirements.

5.2.5.2 Inspection of Numerically Machined Hardware

Post-Process Inspection--The industry-wide method for dimensional inspection of numerically machined components/hardware primarily consists of post-process measurements. This method requires the fabrication to be complete or partially complete and the inspection accomplished as a separate operation. For products having a high volume of diverse geometry, complex design, and many component parts, this method of inspection has an adverse impact on costs and schedules.

In-Process Inspection--In-process inspection has been deemed the most feasible way to achieve configuration verification on numerically machined hardware. In-process inspection is generally accomplished: 1) during the actual machining operation, 2) at intermediate steps during machining, or 3) at the conclusion of machining but prior to part removal from the machine. Stage 1) would be the most cost-effective, as the inspection would be complete at the conclusion of the machining operation without additional handling.

The introduction of CAD/CAM emphasized the need to develop an advanced inspection capability which can efficiently and

The classification and coding capability provides an interactive graphics design system to simplify creating new designs.

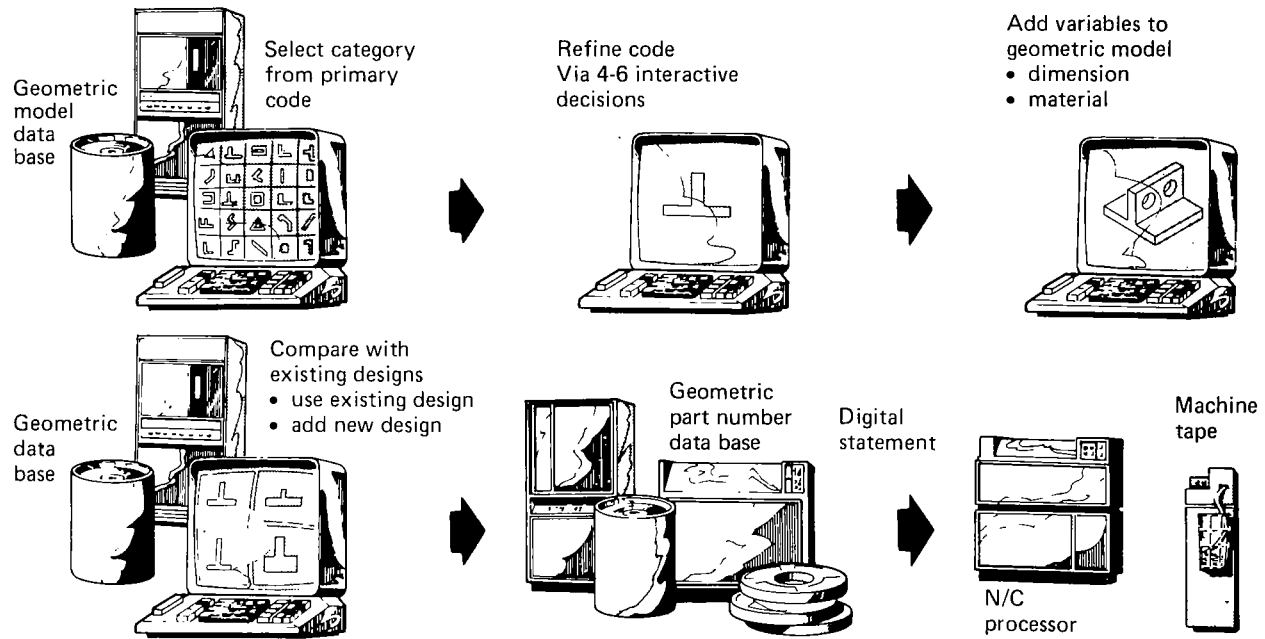

Figure 13.—Classification and Coding

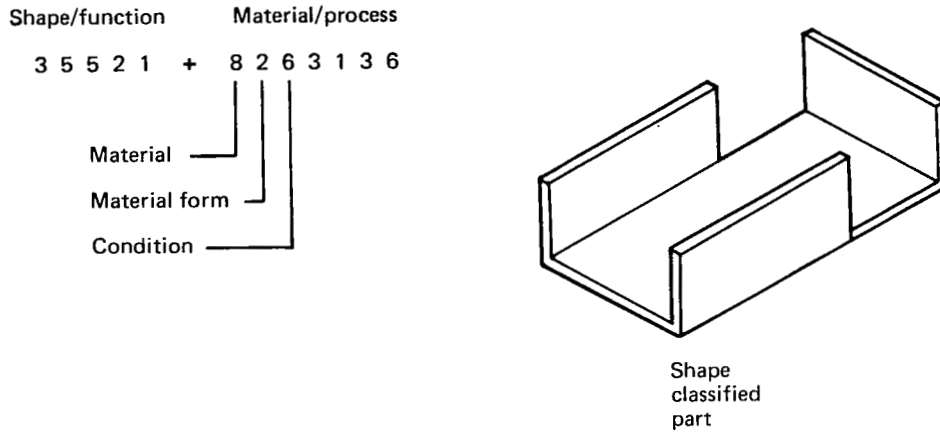

Figure 14.—Example of Part Classification Code

Class/code categories		FUNCTIONS										
		Design avoidance	Design standardization	Computerized process planning	Computer-aided design	Computer-aided manufacture	Group technology	Resource management	Estimating and business planning	Cost management	Spares	Customer service
Tools	Raw materials		X	X	X	X	X	X	X	X		
	Bought-out items	X	X					X	X	X	X	X
	Assemblies/product	X	X	X	X		X	X	X	X	X	X
	Piece parts	X	X	X	X	X	X	X	X	X	X	X
	Cutters	X		X		X	X	X	X	X		
	Fixtures	X		X	X	X	X	X	X	X		

A broad spectrum classification and coding program can provide virtually unlimited benefits.

Figure 15.—Potential Scope of a Classification and Coding System

accurately assess part geometry during numerically controlled machining processes.

Trends--It is anticipated that technical advances in dimensional measurements will keep pace with the higher-volume and more complex NC-controlled machined parts. The areas being explored through approximately ten years of research, as shown in figure 16, will cover:

Advanced probe design for contacting, noncontacting, and three-dimensional sensing systems

The capability to inspect large hardware using numerically controlled machines

Definition of an advanced laser monitor concept for in-process monitoring during numerically controlled machining operations

Simultaneous machining and contour measurements during numerically controlled processing

5.2.6 ORGANIZATIONAL RESTRUCTURING

As the interface between manufacturing and engineering design improves due to the common data base being utilized, the sharp division of disciplines which is presently apparent will tend to disappear. The data base will act as a bridge over this division, thus forcing a restructured organization to develop. The distinction between the design engineering function and that of the manufacturing engineer will tend to diminish as more powerful computing systems are developed to support these activities. Thus the present division of responsibilities will have been lost. To prevent this, the initial decision on how the part is to be made should be determined prior to design formalization.

If the designer has an interactive graphics terminal it will be possible for him to define the configuration required. The designer could then utilize the CRT to define the required cutter path and utilize the large technological data base which will be available to him for determining other manufacturing parameters.

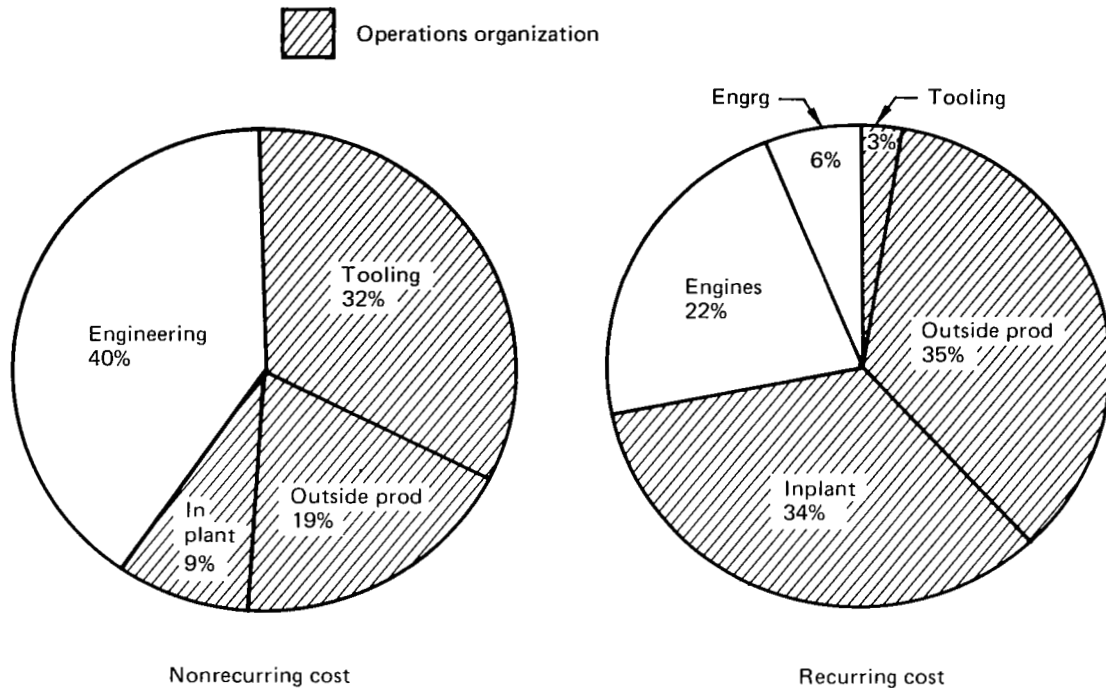

Figure 16.—Advanced Numerical Control Machine Inprocess Monitoring Concept

5.3 FORECASTS

Previous sections of this chapter include changes that are taking place in manufacturing. These are discussed in order to show the direction in which manufacturing technology is going.

This section summarizes forecasts, requirements, and predictions from recent surveys in order to indicate the level of confidence in these developments and to indicate when specific capabilities will be acquired by industry.

5.3.1 Production Technology Advancements Forecast to 1988 (ref. 7)

This study enables us to obtain an idea of long-term developments predicted by a wide range of categories in the metalworking sector including the aircraft and aerospace industries. Although it was released in 1973, its findings are still considered relevant.

The report states: "In order to obtain a meaningful view of future production technology in the metal working industries, a Delphi-type forecast of this subject was undertaken by the Industrial Development Division of the University of Michigan. The forecast was initiated in May 1972 and completed in March 1973. The major contributors to the forecast were managers from US metal working companies." Their collective opinion is presented below.

I. MANUFACTURING SYSTEMS

Range of Applications:

- | | |
|------|---|
| 1980 | Computers will optimize tool life, productivity, and surface quality in 25 percent of the total manufacturing effort. |
| 1984 | One-fourth of all new equipment purchases will be installed in new plants. |
| 1988 | Half of the total machine tools produced will be for use in versatile manufacturing systems. |

Approximately 25 percent of all manufactured parts will be produced and inspected for an entire shift without human intervention.

Control and Maintenance:

- 1978 Sensors will reject bad parts at intermediate steps in "batch-part" transfer lines.
- 1979 Errors or deviations from schedules will be sensed and corrected, automatically, for 25 percent of all manufacturing systems.
- More than 25 percent of purchased equipment will use software developed by the user.
- Improved accuracy control and on-line sensing will cause a 25 percent reduction in part scrappage.

Material Handling:

- 1982 Automated material handling components will account for 25 percent of the cost of new manufacturing systems.
- Fully 25 percent of today's manufacturing areas will be reorganized to take advantage of material handling advances.
- 1986 Adaptive material handling devices will be available and in wide use.

Cost and Justification:

- 1980 One-fourth of all new purchases will be total systems, purchased from a single source.
- Computers and computer support equipment will account for 15 percent of all manufacturing cost.
- 1985 Flow time reduction will be the major equipment justification factor.

II. MACHINE TOOLS

Control Methods:

- 1982 Postprocessor programs will reside in a dedicated mini- or micro-computer.
- 1984 NC controllers will be a hybrid combination of specialized integrated circuitry and micro-computers.

More than 65 percent of NC machine tool production will not have tape readers.

Approximately 35 percent of existing NC machines will be linked to a control computer (DNC).

Accuracy and Quality Control:

- 1980 Surface roughness will be measured and controlled for more than 20 percent of all cutting and grinding operations.
- 1982 One-fourth of all discrete part production will require accuracy and/or quality standards that meet or exceed the best available today.
- 1983 The best attainable machine tool accuracy will have improved by 50 percent.
- On-line gaging will be included on at least 25 percent of all new machine tools.

Adaptive Controls:

- 1980 One-fourth of new machine tools will have adaptive controls as standard equipment.
- Ten percent of existing machine tools will be fitted with adaptive controls.
- 1984 Adaptive controls will account for 20 percent of the cost of a new machine tool.

Productivity:

- 1980 Cutting time increases will improve machine tool productivity by 25 to 30 percent.

III. COMPUTER APPLICATIONS AND PROGRAMS

Part Programming Developments:

- 1980 A standard language will be available for on-line program modification on a modest control computer.
- A computer software system for the full automation and optimization of all steps in part manufacturing will be used for at least 25 percent of all parts.

Part programmers will be eliminated on 25 percent of NC produced parts. Geometric data will be generated by the designer and all technological data will be generated in the computer.

Mock-ups and/or profile work will be eliminated on 25 percent of all die construction.

1982 One-fourth of all formed parts will be generated by complete software systems that optimize product, tool, and process considerations.

One-fourth of all tools and dies will be engineered and/or designed with computer graphics.

Program Verification

1977 More than 25 percent of all NC produced parts will be verified with software and display devices rather than on the machine tool.

Maintenance and Control Software:

1978 About 25 percent of all equipment failures will be detected and diagnosed by on-line software.

1980 Software methods for locating individual parts in a manufacturing facility will be available.

Instantaneous displays comparing scheduled versus actual conditions will be employed in 25 percent of all manufacturing operations.

More than 25 percent of all machine loading and scheduling will be done with computers.

Management information systems, capable of a significant improvement in economic performance, will be in wide use.

1988 One-fourth of all factories will be able to commit and process complete orders without any paperwork.

Standardization:

1978 Standardization of software will be accomplished in at least 25 percent of all developments.

1979 Group technology concepts will be used on 25 percent of all manufacturing applications.

1985 The use of standard data will permit DNC systems to be used with consistent performance and predictable time values.

Data Banks and/or Special Computer Resources:

1982 Large data banks, central and external to the company with the machine tools, will be available.

1985 More than 50 percent of all records, drawings, etc., will be stored in computer memory and accessed by automatic drafting equipment.

1987 A majority of US industrial leaders will be willing to participate in sharing manufacturing data.

IV. PERSONNEL AND SUPERVISION

Total Labor Force:

1976 The major equipment justification factor will be the reduction in labor hours per unit output.

1979 More than 25 percent of all US metalworking personnel will be directly involved with NC and DNC.

1982 The production labor required per unit output of discrete part production will have decreased by 25 percent.

Programmers:

1977 Part programmer time per average part will be reduced by 25 percent.

1980 Computers and software support will account for 10 percent of the manufacturing direct labor force.

1988 More than 50 percent of all US metalcutting operations will have a DNC specialist.

Part programmer time per average part will be reduced by 65 percent.

Managers:

1980 A new breed of production manager, familiar with computer methodology, will be commonplace.

1988 A 10 to 20 percent reduction in intermediate level management per unit of work will result from advances in information networks.

In addition to conducting the study to obtain a technological forecast for the U.S., the results were compared with results obtained in 1971 from a Delphi-type forecast by the membership of CIRP, an international group of production research personnel. The results obtained from these two studies were found to be similar.

5.3.2 AFCAM (ref. 8)

It was proposed during the AFCAM project that the transfer and application of existing computer-aided manufacturing (CAM) modules be promoted and new CAM modules that were shown to have a high priority of need be developed. One of the tasks during the program was, therefore, to identify and prioritize a basic set of modules with common potential application to the aerospace industry. The set of modules prioritized did not take account of all projects suggested for development; these have been listed below.

The data received during the AFCAM survey was not sufficiently detailed to obtain a clear understanding of the different companies' requirements; often, titles only were submitted. However, the list indicates CAM capabilities that aerospace companies presently lack but are interested in developing. It can therefore be used as an indicator of the direction that we are traveling.

CAD/CAM interface

Data base of drawings:

- Optimum data base
- Retrieval of CAM data base
- Standards and Specifications
- Machinability data

Configuration management:

- Audit of manufacturing and design product definition files

Group technology:

- Part classification (plant layout)

Computer-aided planning:

- Process planning optimization
- Prepare process sheets
- Process planning
- Real-time work instructions

Bills of material:

Assembly log

Scheduling

Machine loading and scheduling:

Production scheduling

Upgrade shop order control:

Production control

Manufacturing control

Inventory control

Increase machine tool utilization:

Machine monitoring

Monitoring system

Material handling monitor

Cutter selection and design:

Tool selection

Tool design

Implement change notices rapidly:

Visibility when change notice is at shop floor

Real-time cost/schedule performance:

Cost schedule control

Predict cost data:

Determination of producibility and cost of product

Direct numerical control (DNC):

Computer numerical control (CNC)

NC verification system

NC tape verification

Preparation of NC document

Enhance NC programming procedure

Adaptive control

Single point automatic size control

Laser computer assisted size surface characteristic
condition and adaptive control

Programmed path axis monitor

Programmed path cutter monitor

NC tape production electronics

Automated electronic assembly:

Integrated manufacturing line

Computerized assembly

Automatic drilling and assembly device

Digital electric probe

Quality control:

- Functional testing
- Simultaneous inspection
- Thermographic control/inspection applied to processing and electronic assembly

Automatic workpiece handling:

- Automated warehousing

Simulation:

- System simulation for capital equipment
- System simulation
- Factory simulation model

Remote computer graphics:

- Low-cost computer-independent graphic terminals
- Graphic shop order location and status
- Computer graphics part programming
- Computer graphics tool design
- Art master production electronics

Procurement:

- Preparation of purchase orders

Man/computer interface

Wireless terminals

Report generator

Optimization of metal cutting

The AFCAM program which was concluded in March 1974 received favorable responses from the aerospace industries, the Air Force, and the Department of Defense. The integrated computer-aided manufacturing (ICAM) project has recently been started and is based on the results and recommendations of AFCAM.

The Government's involvement in the development of CAM technology will broadly effect industry and lead to "standard" solutions to common problems. This participation will make CAM systems more economically justifiable and expedite their availability.

5.3.3 CAM-I, A VIEWPOINT (REF. 9)

C. M. Link, general manager of Computer Aided Manufacturing, International, Inc. (CAM-I) was recently asked what developments could be expected in the next decade. Although CAM-I covers more than just the aerospace industry and is actually a "quasi-broker" for establishing research projects among its members, which are

drawn from industry, academia, and government," it is thought that the following predictions by Mr. Link could as well be applied to the aerospace industry alone.

- "1977 Automated planning systems will be available to generate process sheets for machined and sheet-metal parts, castings, forgings, and electrical components and assemblies.
- "1978 Advanced automated planning systems will begin to be applied in large companies.
- "1980 Medium- to small-size companies will start to use automated planning extensively. Minicomputers will be in wide use for shop monitoring and control functions. Software systems will be highly modular and of similar designs, and standard communication methods will be used.
- "1983 Full mathematical/geometric capabilities will exist for design and manufacturing-engineering use.
- "1985 Minicomputers will become dedicated to line and management functions in a hierarchical structure. The use of large computer systems in functional areas will decrease; they will be used more for solving large corporate analysis problems."

5.4 CONCLUSIONS

We are now in what may be the fastest changing technological era ever, supported by the development of the computer and its application in the scientific, business, design, and manufacturing world. This section has outlined the changes that are taking place in manufacturing and has indicated developments predicted. It will be realized that these predictions are general in nature and that no two companies or plants within a company will ever be at the same level of automation. Different problems will have higher priorities within different plants, and different solutions might be chosen to overcome these problems. Therefore, although attempts are being made to provide common solutions to problems through such endeavors as AIA, ICAM, and CAM-I, only limited portions of computer-integrated manufacturing will be the same within different aerospace companies at any particular time.

Although we may perform studies and predict future trends in order that we may plan for their occurrence, the plan itself must be dynamic if we are to account for differences in predicted and actual occurrences. The period under consideration covers a number of years during which the state of the art will change. Since all changes that will occur cannot be anticipated, we are

only able to identify developments based upon technology that is known today. This does not mean that such a prediction cannot be of benefit, only that any plan based on it must be able to accommodate change.

Two factors appear to be most important in the continuing improvement in productivity: first, the improved information exchange between design and manufacturing facilitated by improved data base systems; second, improved small-scale computing hardware leading to a greater number of viable computer applications and correspondingly better direct control of machines and processes.

The continuing evolution of manufacturing computer support systems will definitely influence the direction of the IPAD system design. The trend that will have the most significant effect is the continuing evolution in CAM systems, including:

Direct numerical control

Automation of sheet metal fabrication processes

In-process inspection methods

Automated material handling

Expanded use of minicomputers and microprocessors

Interactive graphics for tool design, NC programming, and manufacturing engineering

Automated assembly techniques

Computer-aided planning

Computer-aided schedule and shop load

Computer-aided process control

Computer-aided inventory control

Group technology

In addition to CAM developments, the trends in computer technology and materials technologies will have a significant impact on the development of an integrated IPAD system.

The most significant computer technology trends are:

Mini- and microcomputers that are used in a hierarchal distributed NC shop and for other production and QC processes

Mini-based graphics systems that support both design and manufacturing functions

Lower costs for mass data storage

The most significant materials technology trend is the increased use of composites and plastics which will require digital part definitions in place of templates and layouts for sheet metal assemblies.

Group technology, with coding and classification of discrete parts, materials, assemblies, and tooling, will be supported by IPAD to the extent that the design to manufacturing integration is established.

6.0 IPAD SUPPORT REQUIREMENTS FOR PRODUCT MANUFACTURING

This section describes the interactions and interfaces where data requirement considerations will impact the IPAD system design. It represents the manufacturing engineering environment of the 1980's and describes how the data is to be used and what information will be stored in the data base by manufacturing and quality control. The volume of data has been estimated. A discussion of general design/manufacturing interfaces appears as appendix B.

IPAD is by definition an evolutionary system. First-level IPAD will not realize more than a sample of its potential capabilities, with perhaps the exception of the data base management and IPIP and IPEX. Even the total IPAD system will evolve from its introduction as it is used by more disciplines. There must be some elements of support for the manufacturing interface in both the first-level IPAD and the initial versions of the total IPAD. The determination of the support elements will be based on cost effectiveness. This section discusses the selection considerations for both versions of the IPAD system. What are the high-cost functions in the manufacturing process? Many support features are common to both design and manufacturing processes. If the capability is there, there should be no great problem to make it available to manufacturing users. These common requirements will be discussed as well as those unique to manufacturing users.

6.1 SUMMARY

The key to efficient product development is to think in terms of an integrated design/manufacturing system. Communication between the two disciplines is essential; it is as important that the designer knows manufacturing's capabilities as it is that manufacturing understands engineering's requirements.

An optimum design has been defined in AIA report Project MC74.4 as: "...a product design based on the fullest understanding of the objectives. These objectives include cost and producibility as well as performance. Consideration of alternatives normally leads to optimum design. A great number of these alternatives involve manufacturing."

It is, therefore, essential that the designer have an understanding of all manufacturing trades that may be made. For this information to be useful the data must be easily accessible, must be accurate, and must be provided quickly enough to be of value in making decisions. This producibility information, when available during the design activity, has a major influence on cost.

Having the ability to preview the "manufacturing method" prior to design and detailing enables the designer to determine what format for the design data best suits the procedure to be followed in producing the part. In this way information would be stored in a data base common to both design and production systems and in a manner that would minimize retrieval and manipulation effort.

In addition to the benefits provided by having manufacturing data available to engineering, and product design information in a format best suited to production needs, there are other advantages of having an integrated system, these being the ability to have common utility programs (e.g., tool design and engineering design use similar stress and analytical programs) and specifications required by both design and production stored in one area.

As the IPAD program is to produce a design data management system, its charter encompasses only activities necessary to the design function. Although there is this limitation on the scope of IPAD, certain types of "manufacturing" information and application programs will have to be considered to be bounded by this program. This type of overlap must be recognized and resolved as ICAM or an equivalent program is developed.

6.2 GENERAL SUPPORT REQUIREMENTS

Even though this document is concerned with the manufacturing interactions with design, the functional organizations that provide the interactions with the design process must be supported by the IPAD system. Regardless of the extent to which the design process is improved in efficiency, if the design intent cannot be translated by manufacturing with ease, the cost advantage is diluted. Consider that the engineering costs of an aerospace product represent only 40 percent of the nonrecurring costs and 6 percent of the recurring costs (see fig. 17) of a total product (ref. 10). This subsection discusses the nature of the required support.

6.2.1 MANUFACTURING USE OF ENGINEERING DATA

One of engineering's primary functions is to provide manufacturing with a technical definition that describes the product in a manner that is complete and easily interpreted.

In the case of IPAD it is envisioned that this information developed by design engineers will be stored in a standard format that may be accessed and utilized by both engineering and manufacturing. This data has its interface with manufacturing as depicted in figure 18.

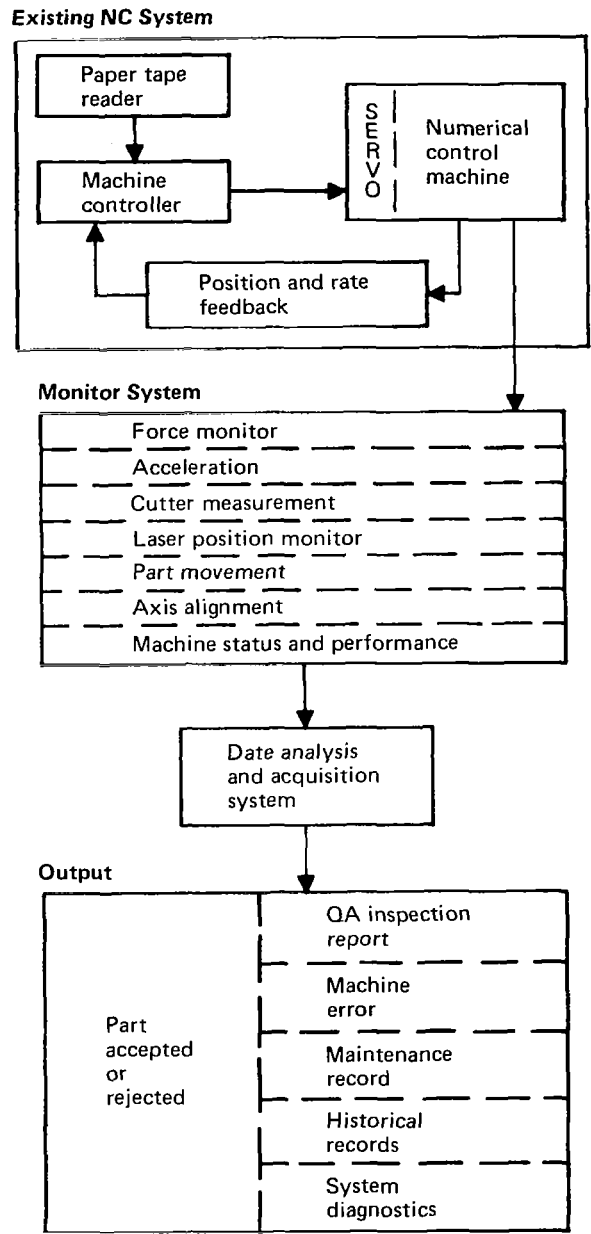

Figure 17.—Program Cost Summary

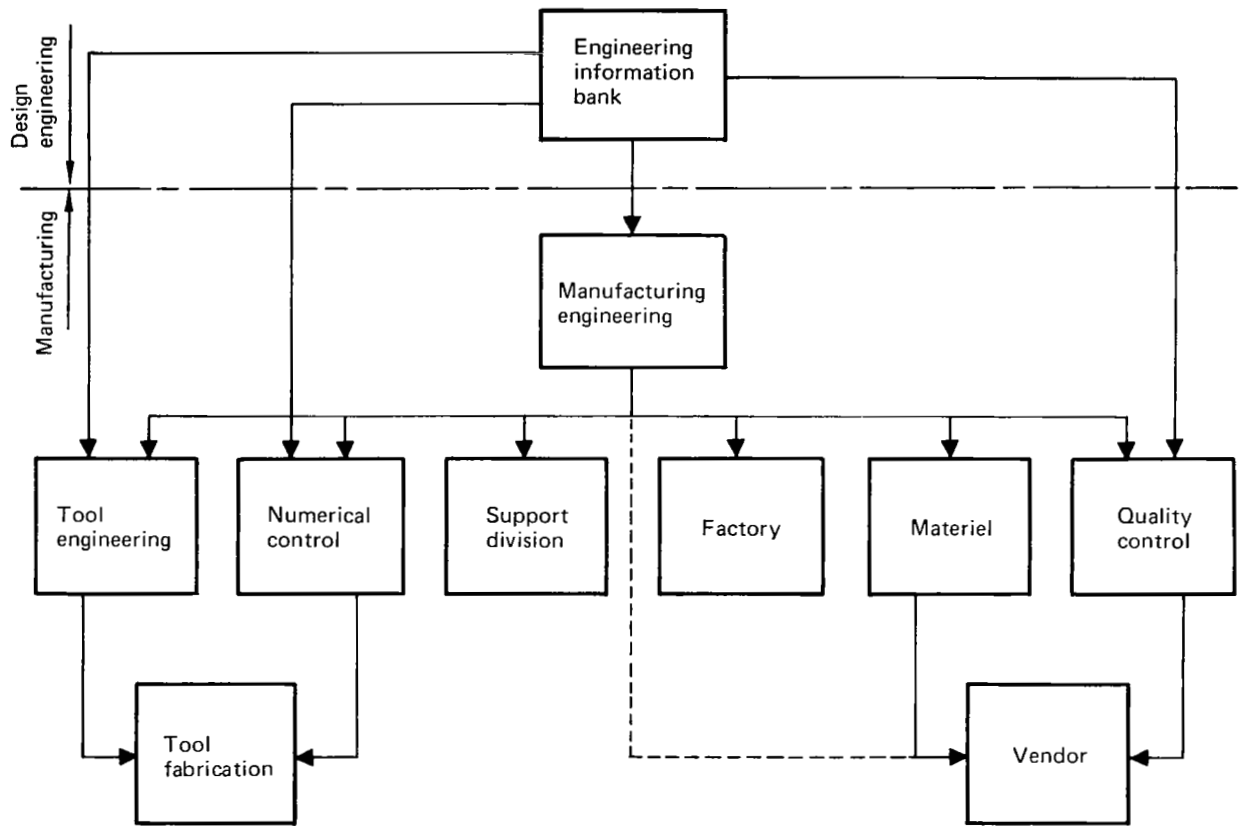

Figure 18.—Data Interface

This diagram is an overview showing the flow of design information into manufacturing. It can be seen that manufacturing engineering is responsible for reviewing information released by engineering and modifying it prior to releasing it "downstream." It is envisioned that the majority of engineering-released information will pass through manufacturing engineering, the only exception being the aircraft surface definition.

In addition to the data flow through manufacturing engineering, both the tool engineering and numerical control programming functions will require access to the engineering data base in order to obtain information regarding the aircraft surface definition. Quality control also has the need to access the engineering data base directly as it is responsible for assuring that the finished product is produced according to the design engineering intent.

6.2.1.1 Manufacturing Engineering

Manufacturing engineering has the overall responsibility for defining the manufacturing sequence, process steps, and tools to be used in the fabrication, assembly, and installation of products. Its primary functions are to:

Interpret engineering design requirements for manufacturing

Break down the product design into logical practical assembly, subassembly, and installation packages

Determine the master, major, and detail tooling requirements

Describe the function, select the type, and order the fabrication of nondesigned tools

Prepare manufacturing plans and specifications for the manufacture and inspection of parts, assemblies, and installations

Assist Materiel in evaluating vendor/contractor capabilities and requirements

Define configuration data, specifications, and tooling requirements for subcontracted items

Advise engineering design groups on manufacturing producibility

Interactive computer graphics will provide a significant tool to facilitate the interpretation of the engineering product design, and develop a logical, practical manufacturing "as

planned* configuration, processing steps and tooling plan, by creation of manufacturing engineering computer graphics data.

Engineering data stored in the IPAD data base will be converted to manufacturing data by creation of a copy of the engineering data file, which may then be manipulated as necessary to define the manufacturing configuration.

Preliminary Planner--The manufacturing system would provide the preliminary planner with the capability to display the design being evaluated for producibility, determine the preliminary planning sequence, and manipulate the geometry to establish an understanding of the concept. Proper size relationships must be maintained as the producibility analysis is performed. Dimensional data would be established to determine process alternatives and facility requirements. The system would also be used to produce illustrations and charts required for reports and documentation.

Project Planner--Manufacturing engineers in the project planning groups (wing, body, systems, passenger accommodations, and avionics) perform the assembly and installation planning functions. It is the project planner who determines the manufacturing configuration of the parts which are ultimately to be assembled and installed to satisfy the engineering design. They determine which holes will be omitted prior to assembly or installation and where excess material will be added to detail parts for trimming after assembly or installation.

The manufacturing system will maintain the integrity of the original design but allow an overlay representing the manufacturing configuration. The data would be transmitted as a file to the detail planner and downstream organization.

It is expected that the project manufacturing engineer will access and utilize information stored in the IPAD data base by:

Locating the appropriate engineering data file (fig. 19.)

Accessing the engineering data, generating a copy, and creating the manufacturing data file

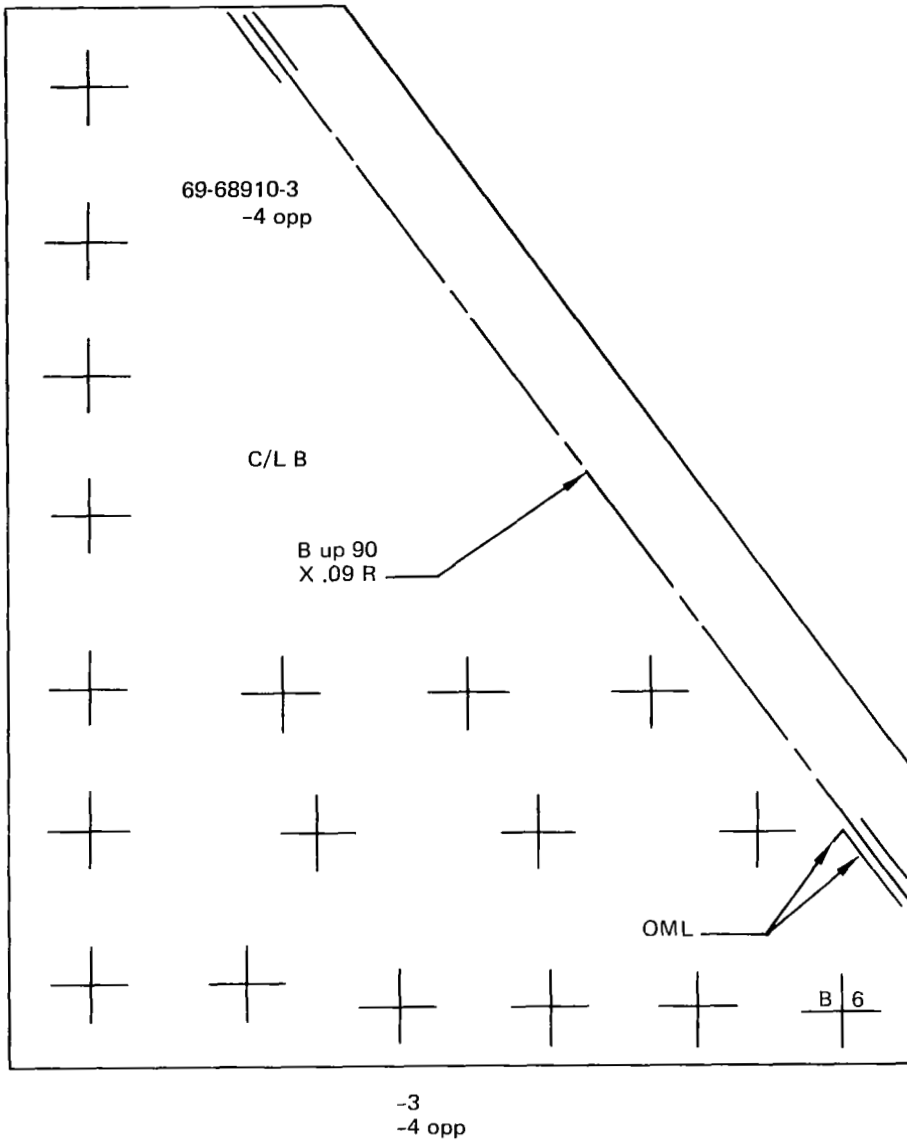

Figure 19.— Engineering Configuration

Utilizing the manufacturing system he will then:

Add/delete/alter parts/features as necessary to create the detail, assembly, or installation "manufacturing configuration" data file (see fig. 20).

Add a manufacturing identifier, change level indicator and enter his security code.

Generate the manufacturing plan.

Submit the plan and corresponding data file for checking.

The checker approves the plan and data file, enters his security code, and releases both for downstream use. The manufacturing configuration data file identifier and change level indicator are then entered on the data file index.

Detail Planning--Detail planning is generally performed within several specialist groups as described in the following paragraphs.

A group known simply as "detail planning" prepares manufacturing plans for sheet metal detail parts and minor (lot time) assemblies. Next, a group of process planners prepares manufacturing plans for metal bond, weld and duct, and fiberglass assemblies and component detail parts. A group known as "machine planning" prepares manufacturing plans for machined detail parts.

All detail, process, and machine planning groups prepare "tool orders" for the fabrication of nondesigned tools. Planners also prepare tool design requests for tool designs and numerical control program service requests for numerical control machining operations.

The system would provide the detail or structural design geometric data necessary for the detail planning function. The system would facilitate the task of the planner by allowing manipulation of the geometry to determine optimum part orientation and machine or facility selection.

The detail process or machined parts manufacturing engineer would access the manufacturing system and utilize the manufacturing configuration as follows. (Note: At this point many of the manufacturing configurations may be identical to the engineering data file.)

Locate the appropriate manufacturing configuration data file

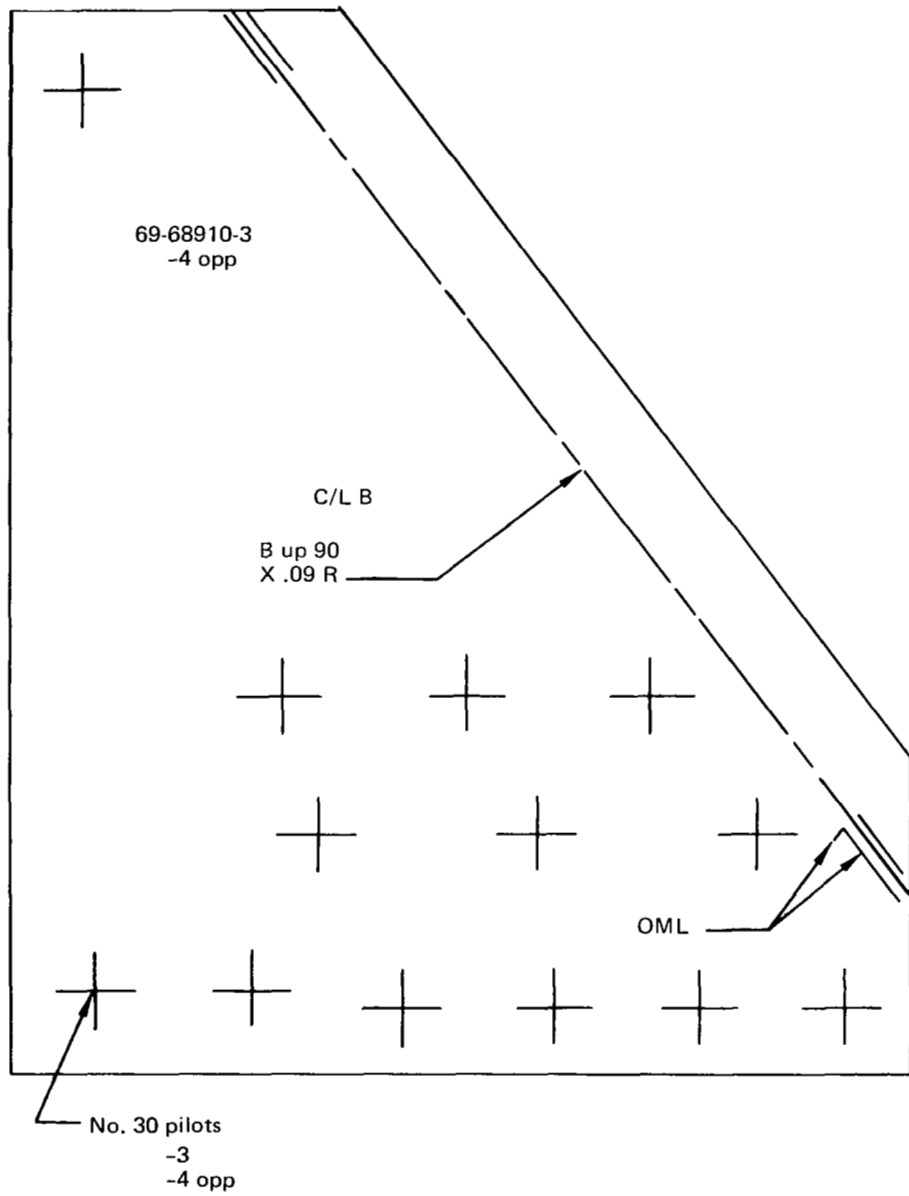

Figure 20.—Manufacturing Configuration

Access the data and generate a copy, creating the "as-planned" data file.

Add features as necessary (excess, tool tabs, hold-down lugs, etc.) to generate the fabrication configuration data file (fig. 21).

Add an "as-planned" identifier change level indicator and enter his security code.

Generate the manufacturing plan.

Submit the plan and corresponding data file for checking.

The checker approves the plan and data file, enters his security code and releases both for downstream use.

The "as-planned" configuration data file identifier and change level indicator are entered on the data file index.

It can be seen, therefore, that, except for preliminary planning, it is only necessary to access the engineering data regarding product definition once per release or change for manufacturing engineering.

Preliminary planning is primarily concerned with producibility; it supports the design function by providing this data.

Preliminary planning will, under this initial scope of IPAD, be carried out in the conventional manner and will not use IPAD as an interface.

6.2.1.2 Tool Engineering

Tool engineering has the basic responsibility to provide the most appropriate and economical tools required for the fabrication, assembly, and test of products (figures 22 and 23 illustrate the breakdown of tool types and the relative cost of tool engineering in relation to the total tooling costs. Tooling costs are approximately 32 percent of nonrecurring costs and 3 percent of recurring costs of a product. (See fig. 17.)

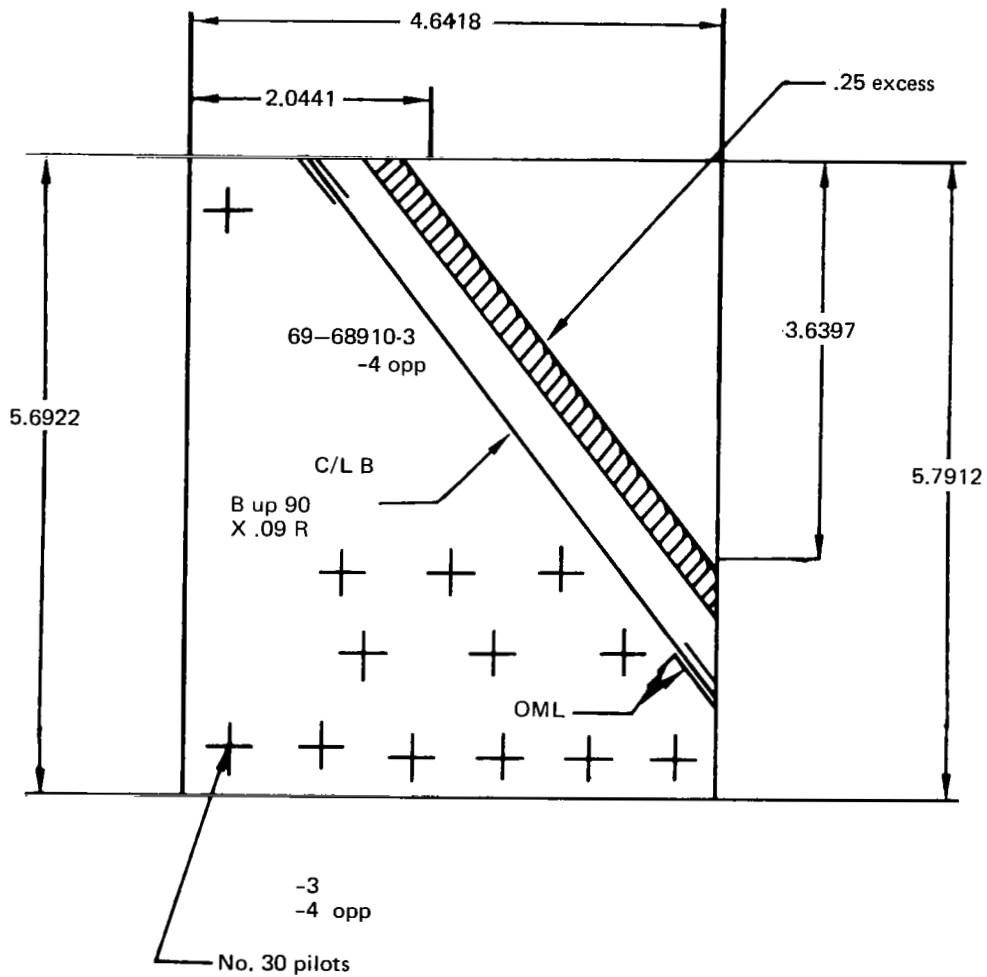

Figure 21.—The “As-Planned” Configuration

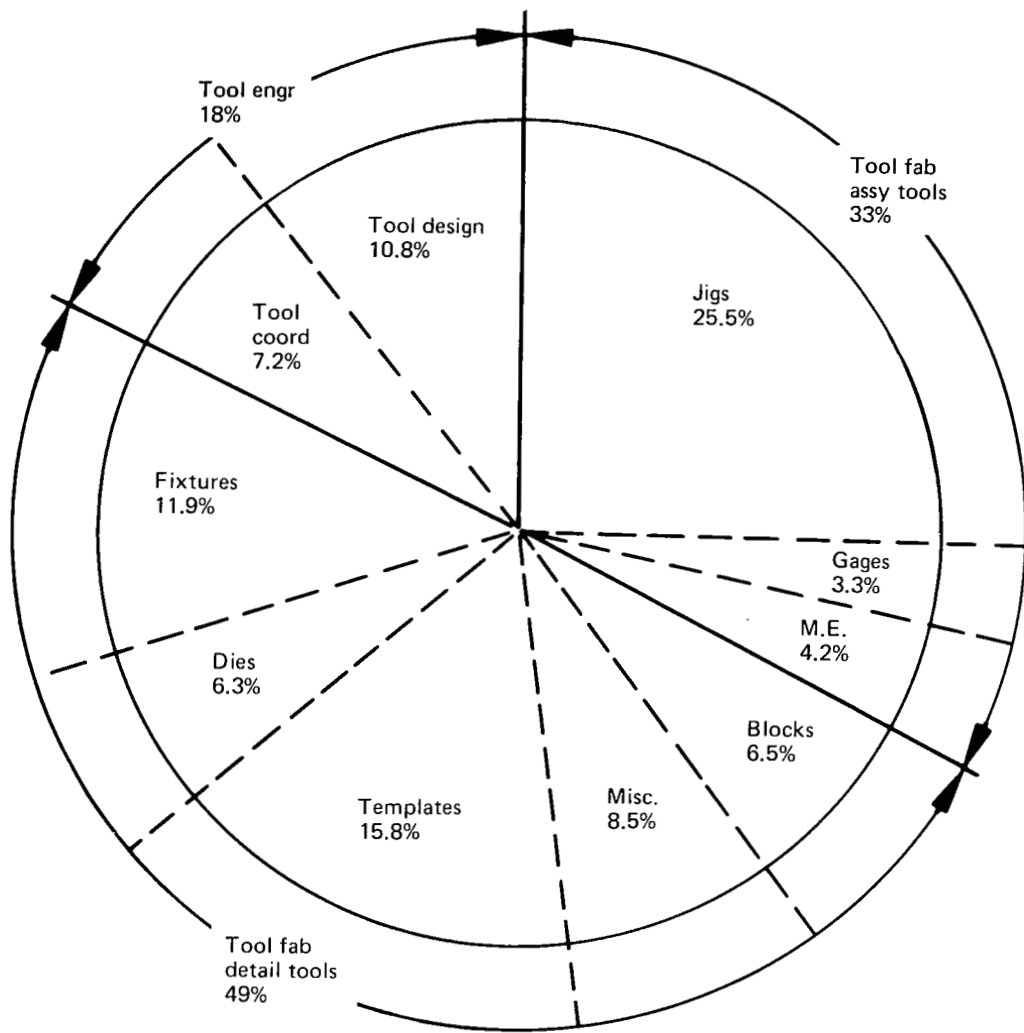

Figure 22.—Total Tooling

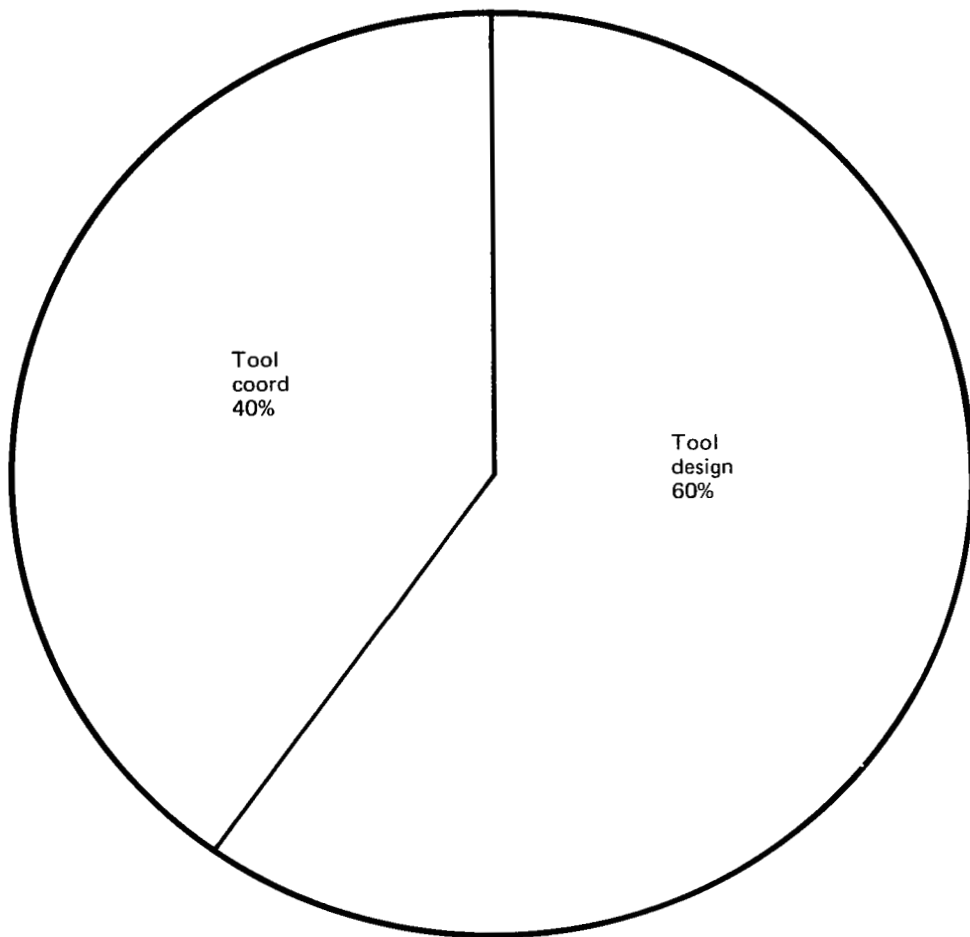

Figure 23.—Tool Engineering

Preliminary Planning--Preliminary planning normally takes place prior to a new program go-ahead or major modification. Working with descriptions of structural airframe design and preliminary design configuration drawings, the manufacturing and tooling plan is developed jointly with manufacturing engineering for assembly of the airplane. Preliminary tool designs are then made to illustrate the approach to be used. The output of this activity is a document currently called a "manufacturing and tooling plan."

Concept Definition--Using a tool design request issued by manufacturing engineering which identifies the element of the manufacturing and tooling plan to be satisfied, the concept definition is developed into the final design.

Detail Design--The detail design activity completes the tool as specified in the tool design request. This process is accomplished by: a) using the manufacturing configuration outlined in its proper orientation; b) creating necessary tool components by means of basic geometric construction techniques; c) establishing proper configuration through calculating capabilities; d) identifying standard components; e) adding necessary dimensions, notes, and symbols; and f) creating a material (parts) list to constitute the design functions.

From figure 18 it can be seen that manufacturing engineering provides the tool design group with definition of the parts to be produced, thus making no impact on the IPAD data base. Only for preliminary design information and the retrieval of aircraft surface definitions would it be necessary for tool design to access engineering data directly.

6.2.1.3 NC Programming

The transition to interactive computer graphics (ICG) automation for NC programming is presently underway in the aerospace industry. Although the capability to support the programming activity is presently limited, development is taking place in order to meet the objective of reducing the effort required to create control instructions for NC equipment. This will be accomplished by:

- a) Eliminating the need for interpreting engineering product design and supporting tool design geometric descriptions
- b) Increasing the use of in-stock and lower-cost cutting tools through automatic tool description and selection
- c) Optimizing cutter performance through automatic feed and speed computation and cutter path generation

- d) Increasing programming productivity through post-processing and control tape generation at the most efficient location
- e) Reducing cost of computing through the use of less expensive equipment and more efficient data handling and storage

Only a) and e) of the above items will have an impact on the IPAD design; the other points are strictly manufacturing items.

Using ICG, the NC programmer must be able to extract the complete geometric description of the part. This information will then be used by most of the companies in a local system, thus enabling the NC programmer to create additional geometry and additional required information. The programmer will use the automatic motion-generating routines provided by ICG to create the cutter paths as well as provide an APT (or similar) language source code describing the paths.

An additional input required to create a cutter path is a cutter description. Certain preliminary parameters are required for computational purposes.

The ICG system will have access to a library of the most commonly used cutters described by the following features: cutter diameter, corner radius/chamfer, number of flutes, and flute length. The user will satisfy the APT program requirements as well as define parameters needed for feed and speed calculations by selection from a menu. This information is then processed and stored for use by the shop.

6.2.1.4 Quality Control

Quality control has the responsibility to assure that the design and other applicable requirements are met. Throughout the fabrication process, product inspection is responsible for verifying that the product is built according to design specifications. Inspection records for the major assembly and installation process are maintained and become part of the delivered documentation to the customer.

Receiving inspection verifies that purchased items and outside production components meet the purchase order specifications. Inspection also maintains operations at the source of outside production fabrication. There is also a tool inspection task that assures that tools are fabricated to meet specifications of design, tooling, and manufacturing engineering.

All of the above functions may require that quality control personnel access engineering product definition in order to verify

product configuration. It is necessary to go directly to engineering data base in order to obtain information that defines engineering intent without manufacturing's modifications.

6.2.2 INFORMATION FLOW

Manufacturing interactions with the design organizations begin early in the conceptual phase of a new airplane program and continue throughout the design and fabrication of the product. The initial interactions provide two-way communication in order to inform manufacturing of early design configurations so that manufacturing capabilities and fabrication costs may be considered. These interactions, although not comprising large volumes of data flow, are extremely crucial to the design process. The engineering release, on the other hand, is primarily a one-way information flow. It is this function that comprises the major information exchange in terms of volumes and rates of data flow.

It is necessary that the extent of the potential impact of support requirement for manufacturing and quality control on the design of the IPAD system be evaluated. In order to do this, an attempt has been made to analyze data volumes, format, and frequencies between manufacturing, quality control, and the IPAD data base.

6.2.2.1 Engineering Release

The drawing release function provides an administrative and clerical service to the engineering design organization and acts as the major interface between the design organization and the downstream organizations using the engineering drawings and related data.

In support of the engineering design organization, the release function assigns and maintains appropriate records for drawing and part numbers, drawing sheet numbers, revision identifications, and control numbers for supportive engineering documentation. It receives the completed packages of engineering drawings and data from the design groups, processes the packages to complete the record-keeping function, and issues the drawings and related data to the reproduction unit for distribution to the using organizations (table 1).

In support of user organizations, the release function provides engineering data that is required to accomplish the planning, ordering, producing, or purchasing and accounting for all hardware components. It produces indexes of drawings to be supplied customers representing the configuration of the product he has purchased.

Inherent in an automated drawing release system is the ability to monitor schedule performance (actual drawing release dates versus scheduled dates), and to generate timely reports to management identifying actual or impending schedule non-conformance which may have an adverse effect on the program. Additionally, it may be used to provide extracts, audits, and statistical data to satisfy either standard or special report requests. It contains a historical log which may be used to trace the changes of product configuration.

This released information would be stored in the IPAD data base available for use by manufacturing.

6.2.2.2 Data Storage

The storage requirements to enable this system to support manufacturing have been calculated based on the assumption that the majority of engineering released data will be in computer format by 1985. It is thought that 100 percent of the aircraft surface definition would be accessible and 90 percent of the data presently carried on drawings will be stored in a computer.

In order that storage requirements can be quantified each IPAD user will be required to analyze his own needs. The statistics presented below are indicative of The Boeing Company's expected requirements.

Aircraft Surface Definition--The term aircraft surface definition denotes a computerized form for mathematically defining the geometry of the aircraft and permitting the extraction of this information from the computer in such a form as to facilitate the fabrication and assembly of the product.

Manufacturing has found the computer-based system defining the aircraft surface to be an extremely useful tool. This information, in addition to eliminating the need for many master gauges, when combined with N/C techniques permits the direct fabrication of parts, tooling, and assembly fixtures with greater speed, economy, and precision than is possible with conventional methods.

This system is designed to accept geometric information presented in two-dimensional form on a geometric parameter drawing. This drawing defines the exterior or interior geometry of a product in terms of control curves, points, and cross-section view outlines. The control lines are commonly defined either by an equation or by the necessary control points and slopes.

The aircraft surface definition is generated by duplicating in the computer the geometric information presented in the geometric parameter drawings. That is, each control line shown on

the geometric parameter drawing is represented in the computer by an equation or series of equations. If the equations of the control lines are given, the equations are directly entered into the program. If the control lines are defined by control points and slopes, the coordinates of those points and associated slopes are entered, and the coefficients of the equation are calculated and automatically entered into the definition program.

Figures 24 and 25 depict the size of the definitions used at Boeing and provide an estimate of total storage requirements for this form of data.

Drawing Data--Drawing information comes in the form of:

- a) Books--Parts lists, specifications, drawing indices, tubing and wiring installations combine definite engineering data, specifications and dimensions of other definitive drawings.

These book form drawings presently comprise many standard sized pages of information. On the average they have 18 pages, although books with over 100 pages are common.

- b) Engineering dimensioned or scalable drafted drawings, detail parts, assemblies, and installations

The drafted drawings which, with their associated advance drawing change notices, make up the majority of drawings of various sizes from "A" through "J," with the majority of the larger drawings printed half-size.

Tables 2 and 3 show the breakdown of drawing sizes required to support the definition of four aircraft as of October 1976. These numbers continue to increase due to improvements and modifications.

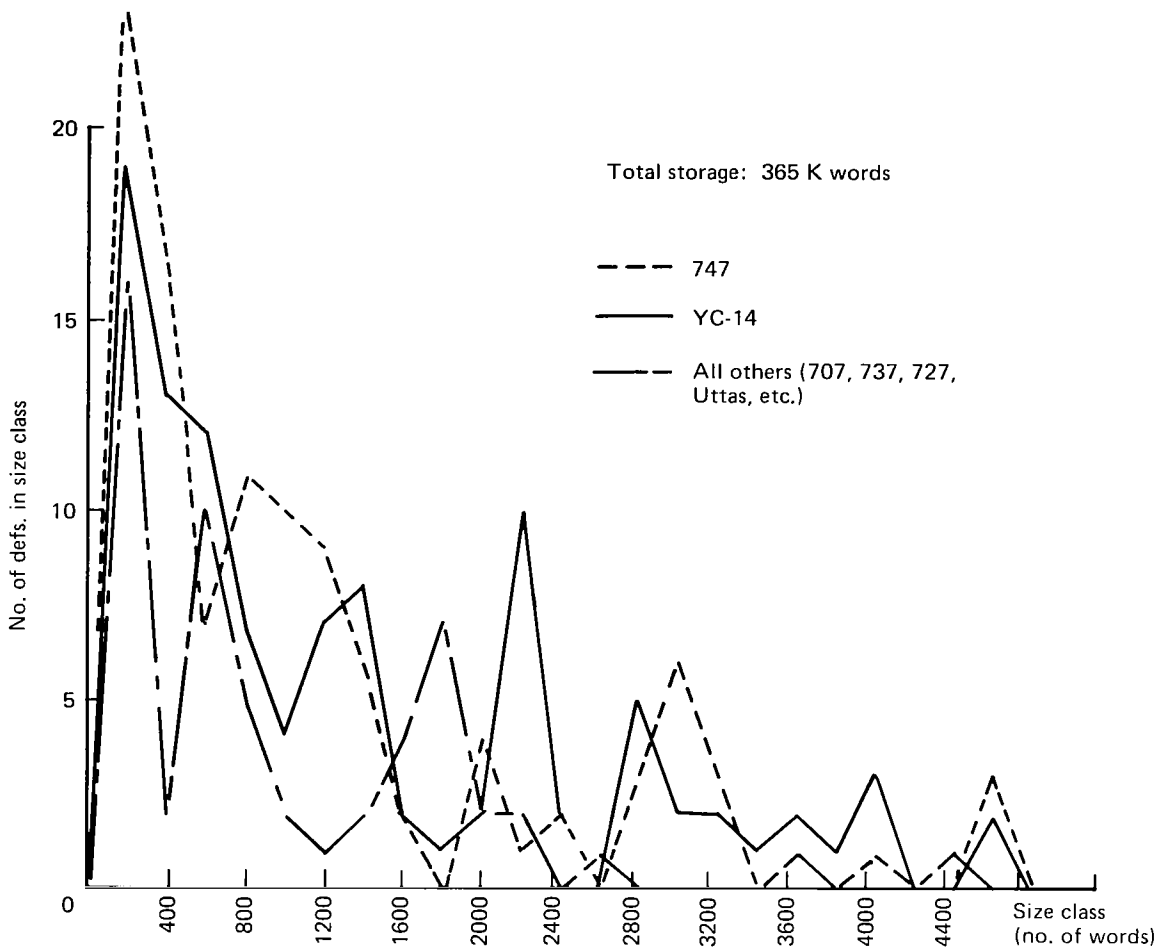

Figure 24.—Aircraft Surface Definition Size Distribution

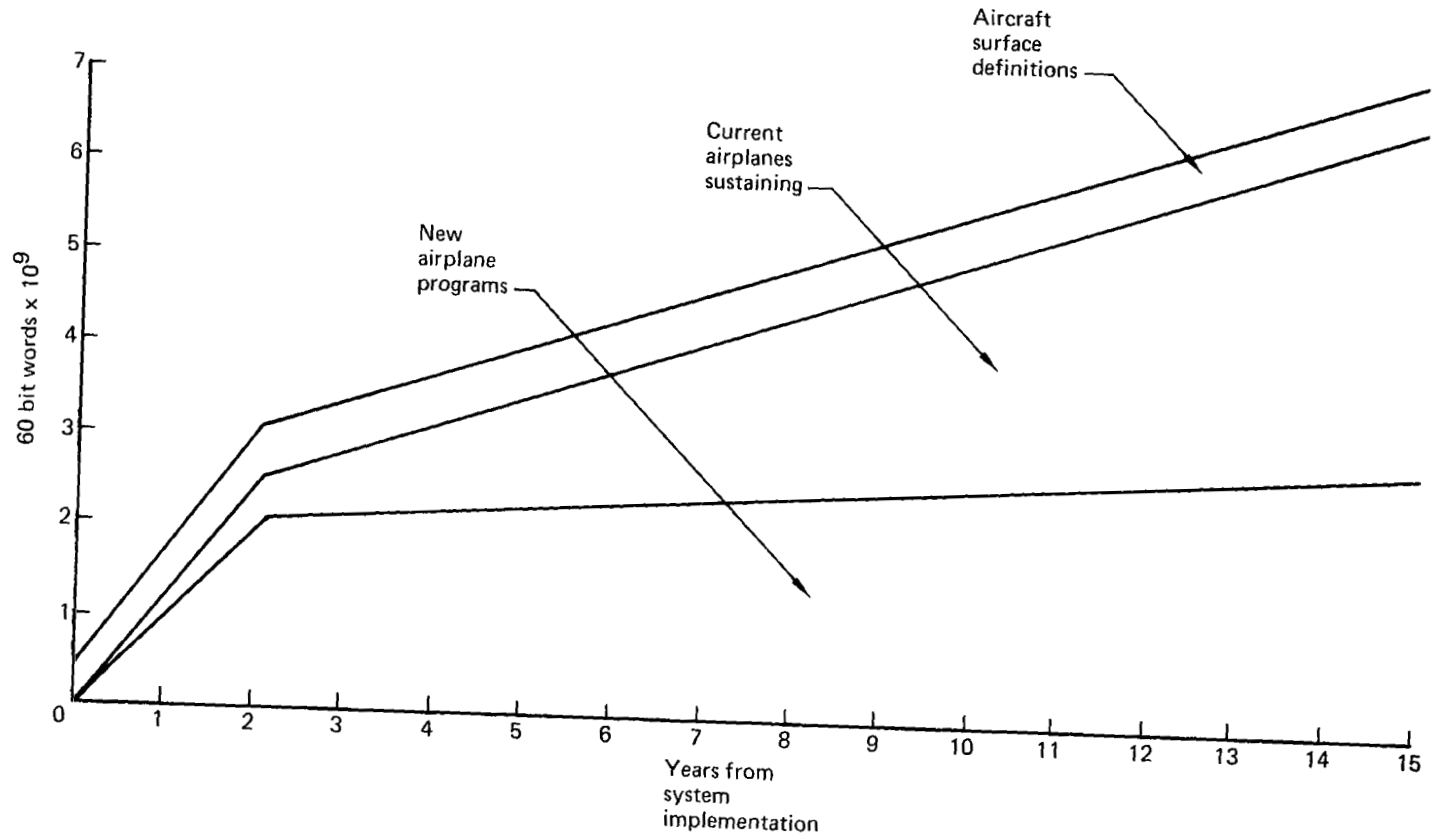

Figure 25.—Storage Requirements

Table 2.—Drawing Sizes

		Percentage of total 707/727/737	Percentage of total 747
A = 1	8½ x 11	38%	6%
B = 3	11 x 17		
C = 6	17 x 22		
D = 9	22 x 34	23%	29%
E (non used)	34 x 44		
J = 5	34 x (125 average)	<u>39%</u>	<u>65%</u>
		100	100

Table 3.—Estimated Present Storage Size

707, 727, & 737			
A size drawings	.08 x 192,000 x 5,000	=	77 m. words*
Book form (18 pages average)	.30 x 192,000 x 18 x 114	=	118 m. words
D size drawing	.23 x 192,000 x 20,000	=	883 m. words
J size drawing	.43 x 192,000 x 60,000	=	4,954 m. words
747			
A size drawings	.06 x 89,000 x 5,000	=	27 m. words
D size drawings	.29 x 89,000 x 20,000	=	516 m. words
J size drawings	.65 x 89,000 x 60,000	=	3,471 m. words
ADCNS	281,000 x 1.6 x 5,000	=	2,248 m. words
			12,294 m. words

(*60 bit words)

Book form drawings applicable to model 707, 727, and 737 airplanes comprise predominantly alphanumeric information or simple graphics that can be handled more efficiently when separated from the picture sheet.

In addition to Boeing-developed data it is necessary to account for vendor drawings, which comprise approximately 8 percent of the drawing files. Presumably, the ratio of different size drawings will be the same as those produced in-plant; however, all vendors will not necessarily utilize graphics to the same extent that Boeing does, and only 50 percent of their designs will be defined digitally.

6.2.2.3 Information Retrieval Requirements

The primary users of drawing information are factory and manufacturing engineering, (more than 80 percent of all charge-outs--estimated), with the factory being the largest single body of users of drawings.

Normally, these users are informed of the drawing number and sheet that they will require so that there is seldom any need to review a number of drawings to determine the particular drawing required. The main requirements in this area are that drawing information needed must always be available on a timely basis and that the information be portable.

Manufacturing engineering personnel are the major users of blueprints after the factory. They withdraw large numbers of drawings in order to locate the one they wish to work with, after which they may spend many hours working with the drawing selected. In general, it is not necessary for these engineers to have portable drawings. They must, however, be able to scan the complete drawing to assimilate information, and they must be able to cross-check with other drawings and change notices to complete the informational requirements. This, it is felt, will necessitate the access of full-size hardcopy drawings. Any system designed must, therefore, give primary consideration to these requirements.

Figure 26 is a schematic to indicate data flow to support manufacturing and quality control. (See appendix B for information types.)

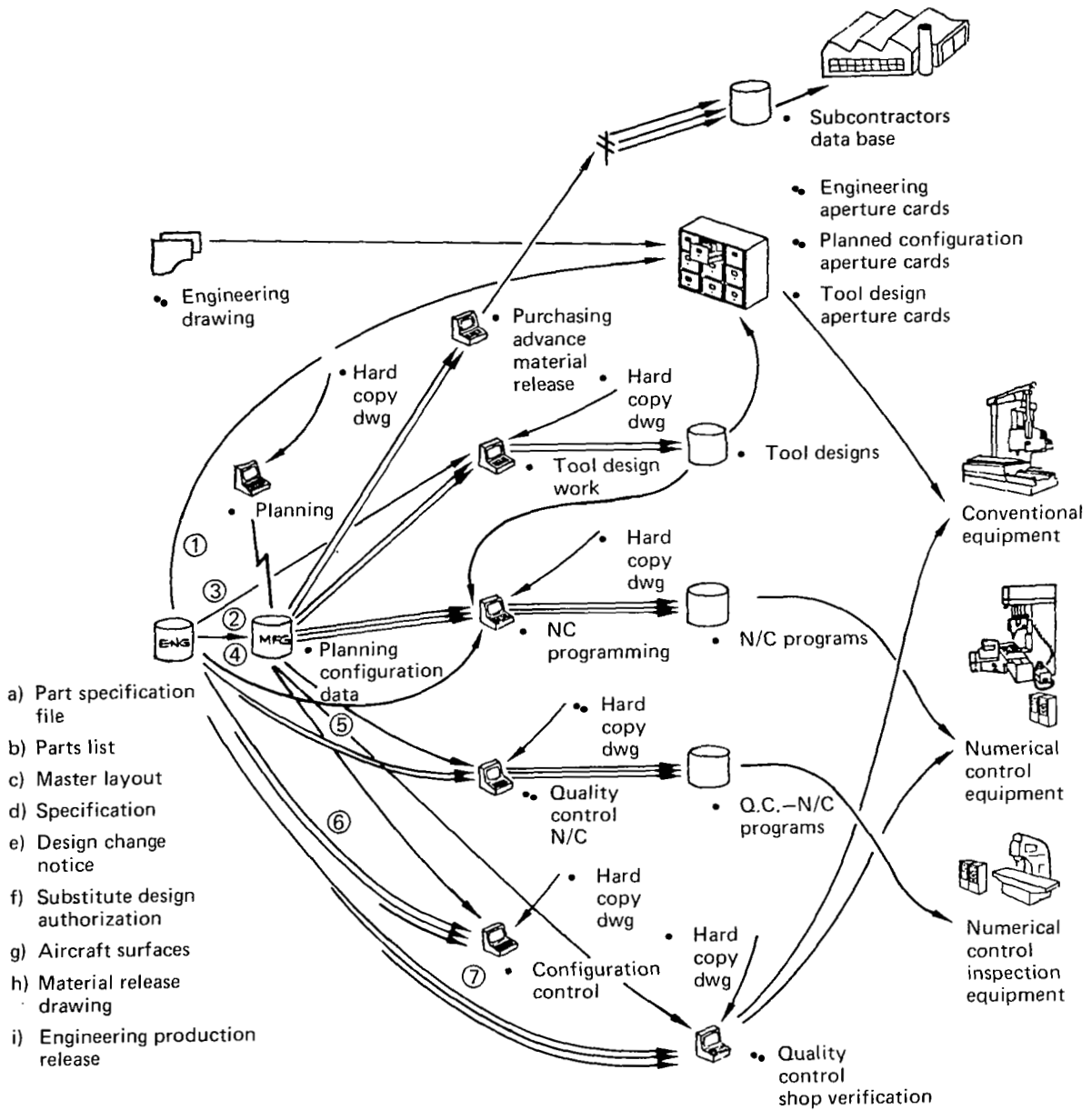

Figure 26.—Engineering/Manufacturing Data Flow

Table 4.—Information Flow: Information Type Matrix

Information flow path (ref. fig. 4.2.2.2-1)

	1	2	3	4	5	6	7
a) Part spec file	✓	✓			✓	✓	✓
b) Parts list	✓	✓			✓	✓	✓
c) Master layout	✓	✓			✓	✓	✓
d) Specifications	✓	✓			✓	✓	✓
e) Design change notice	✓	✓			✓	✓	✓
f) Substitute design auth.	✓	✓			✓	✓	✓
g) Aircraft surfaces			✓	✓	✓		✓
h) Material release dwg.	✓	✓			✓	✓	✓

Utilizing table 26 and the interface definitions in appendix B, a breakdown indicating types of data flowing in each path was developed, as follows:

- (1) On table 4 (preceding page), 100 percent of engineering-released data categories a), b), c), d), e), f), and h), (i.e., all engineering product definition except for aircraft surface definition) will be off-loaded as aperture cards.
- (2) A transfer equivalent to (1) above will also be necessary to copy the engineering data into the manufacturing information bank.

Both (1) and (2) will occur as data is released for engineering use.

- (3) This flow models the extraction of aircraft surface definition information to support tool design, i.e., extraction of g) type information. (Although digital information flow to tool design will increase, the amount of aircraft surface information data will remain the same.)
- (4) This covers the extraction of aircraft surface (i.e., g) type) definition information to support NC programming.
- (5) Quality control and NC programming extracts engineering-released information directly, together with information from the manufacturing information bank. This information will primarily comprise the engineering part configuration, including aircraft surface definition as required. By 1985 it is expected that post-process inspection will be reduced by 50 percent.
- (6) Quality control's configuration control function is primarily concerned with the verification function requiring b, d, e, and i. It is felt that this function will remain at the same level.
- (7) Shop verification is primarily concerned with checking to verify that the product is built according to engineering specifications. This requires direct access to the engineering information files for all types of information. Due to better control in manufacturing, this data requirement is expected to decrease to 50 percent by 1985.

Quantification: Recognizing that a generalized analysis of information quantities released to manufacturing would be of little value, table 5 is based on data actually representative of Boeing's requirements. To ensure that this information is

relevant to other companies, it includes an overview of the products being supported, along with assumptions made in order to speculate on changes that will impact IPAD. Individual companies will have to make their own analysis for each potential application in order to develop their IPAD system definitions.

The data requirements for sustaining mode are based on the present requirements supporting the 707, 727, 737, and 747. These requirements are related not only to rate of production but also to the amount of the product that is made outside of the company.

The percentage of each airplane model that is built outplant is:

<u>Model</u>	<u>Weight (%)</u>	<u>Part Numbers (%)</u>
707	45	
727	31	
737	34	
747	67	40

In order to quantify data flow, information was collected concerning data flow needed in a sustaining environment for the 707, 727, 737, and 747 airplanes. This data was based on current information flow methods converted to digital quantities. Rates for new product release were calculated on known relationships between new product release and sustaining mode requirement as well as on forecast release rates for a new airplane. In addition to the above factors; the time of the day must also be considered. (Two-thirds of all drawings are presently requested during the day shift.) Table 5 illustrates the data flow.

6.3 POSSIBLE BOUNDARIES BETWEEN DESIGN AND MANUFACTURING

Because IPAD is primarily intended to support the design function, the conventional interface between the manufacturing and engineering disciplines has been set as the boundary of the project. A discussion of the possible boundaries follows.

6.3.1 INFORMATION FROM DESIGN TO MANUFACTURING

Figure 27 depicts the accessing and review of engineering-released data by users without the ability to modify it by using the IPAD system. This relationship with the IPAD data base is considered an artificial boundary that will move as the design and manufacturing functions become more thoroughly integrated.

Figure 28 illustrates the fact that manufacturing engineering and tool design could utilize the IPAD system not only to extract and review data but also to manipulate engineering data

Table 5.—Information Access Requirements

Information flow path (ref. fig. 4.2.2.2-1)	New Product Release			Sustaining Mode 707, 727, 737, 747		
	Frequency trans/month	Size (go bit words)	Resp. time	Frequency trans/month	Size (go bit words)	Resp. time
1	2,500 Geom. sheets	60,000	24 hr	600 Geom. sheets	60,000	24 hr
	1,500 Parts lists	2,000	24 hr	250 Parts lists	2,000	24 hr
	2,500 Geom. change	5,000	24 hr	5,200 Geom. change	5,000	24 hr
	1,500 Parts list change	114	24 hr	2,200 Parts list change	114	24 hr
2	2,500 Geom. sheets	60,000	24 hr	600 Geom. sheets	60,000	24 hr
	1,500 Parts lists	2,000	24 hr	250 Parts lists	2,000	24 hr
	2,500 Geom. change	5,000	24 hr	5,200 Geom. change	5,000	24 hr
	1,500 Parts list change	114	24 hr	2,200 Parts list change	114	24 hr
3	70 Aircraft surface defs	800	1 hr	15 Aircraft surface defs	800	1 hr
4	14 Aircraft surface defs	4,000	24 hr	1 Aircraft surface defs	4,000	24 hr
5	6 Aircraft surface defs	450	24 hr	3 Aircraft surface defs	450	24 hr
	350 Parts lists	2,000	4 hr	350 Parts lists	2,000	4 hr
	250 Geom. sheets	20,000	4 hr	250 Geom. sheets	20,000	4 hr
	250 Geom. sheets	60,000	4 hr	250 Geom. sheets	60,000	4 hr
6		114	5 min	7,800 Parts list	114	5 min
		20,000	5 min	3,200 Geom. sheets	20,000	5 min
		60,000	5 min	6,200 Geom. sheets	60,000	5 min
7		6,000	5 min	3,000 Geom. sheets	60,000	5 min

and store it in the IPAD data base, i.e., modify the product for in-process description purposes and utilize the system capability to support the tool design function. These applications of the IPAD system would be identical to the capabilities provided for engineering, the system size being the major difference.

A further extension, although not within the present required capabilities of IPAD, is the translation of engineering into a new format for manufacturing (fig. 29). An example might be the use of engineering-supplied geometry translated to the numerical control source code defining the part. As the translators will be specifically designed for manufacturing's use they will tie outside of the IPAD boundary (in the same manner as technical program elements). The IPAD system could, however, provide the management and control of information of this type.

6.3.2 INFORMATION FROM MANUFACTURING TO ENGINEERING DESIGN

In order to support the IPAD concept it is necessary that manufacturing information regarding costs, producibility, and capacity is available to the design engineer. This information which is conventionally thought of as being in the manufacturing domain, is necessary to an optimal design. It is, therefore, considered that information of this type could be stored in the IPAD information bank for design use (fig. 30).

The method by which this information is generated will remain in the manufacturing domain, as is the responsibility for keeping the data current.

6.3.3 SHARED INFORMATION

A third type of information stored in the data bank is that supporting both manufacturing and engineering equally. This portion of the information bank, although developed under this contract for design use, should be designed to satisfy both areas (fig. 31) rather than being duplicated at a later date for manufacturing.

6.4 OTHER SUPPORT CONSIDERATIONS

The environment of the 1980's will be affected by mini- and micro-computers and the increased computer power available for satellite systems at greatly reduced costs. The satellite systems will be tied into IPAD and to each other. Managers and users representing all facets of manufacturing must be trained to use the integration of systems to the greatest cost and schedule advantage. One way to secure their acceptance and utilization of

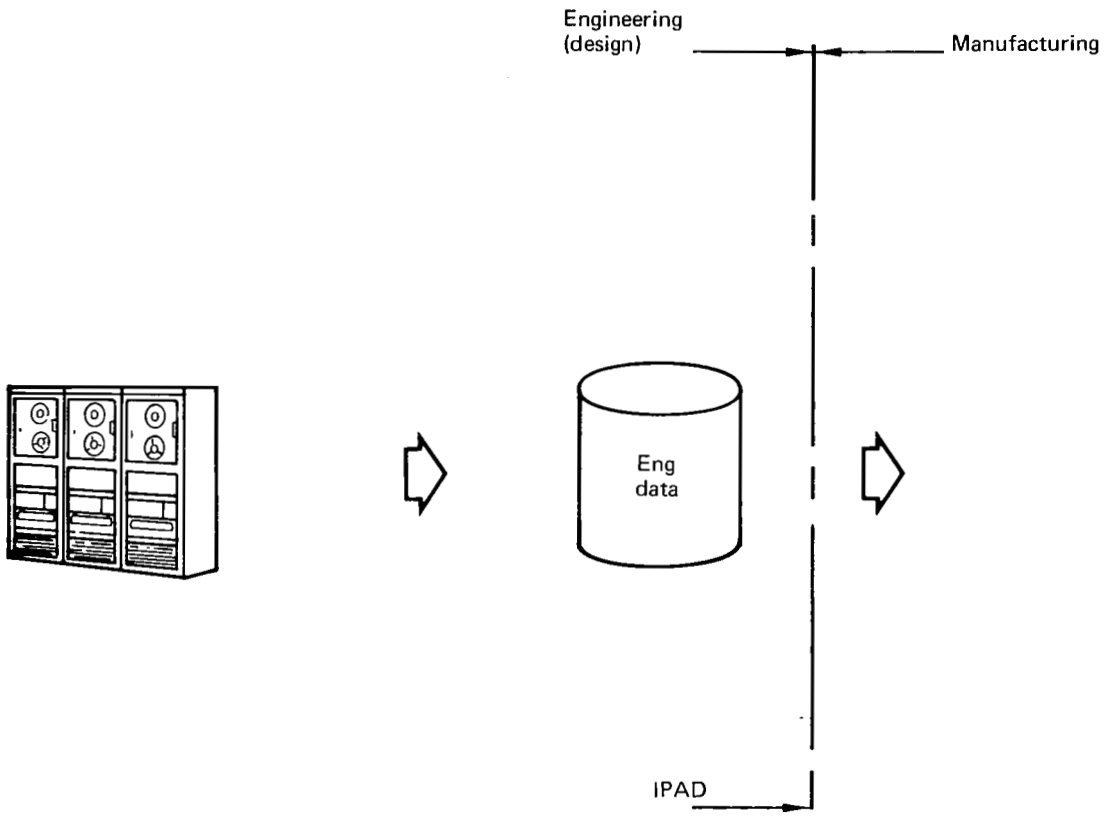

Figure 27.—Design to Manufacturing—Conventional

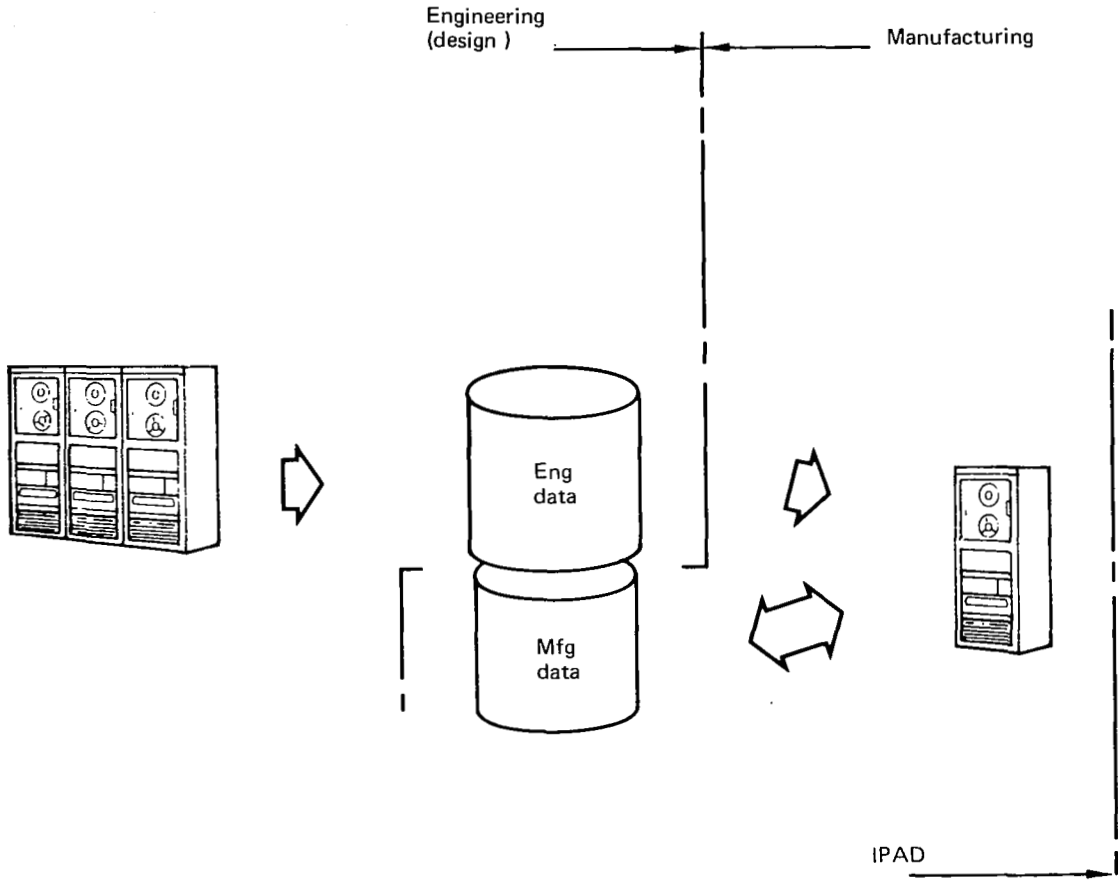

Figure 28.—Manufacturing Utilization of IPAD

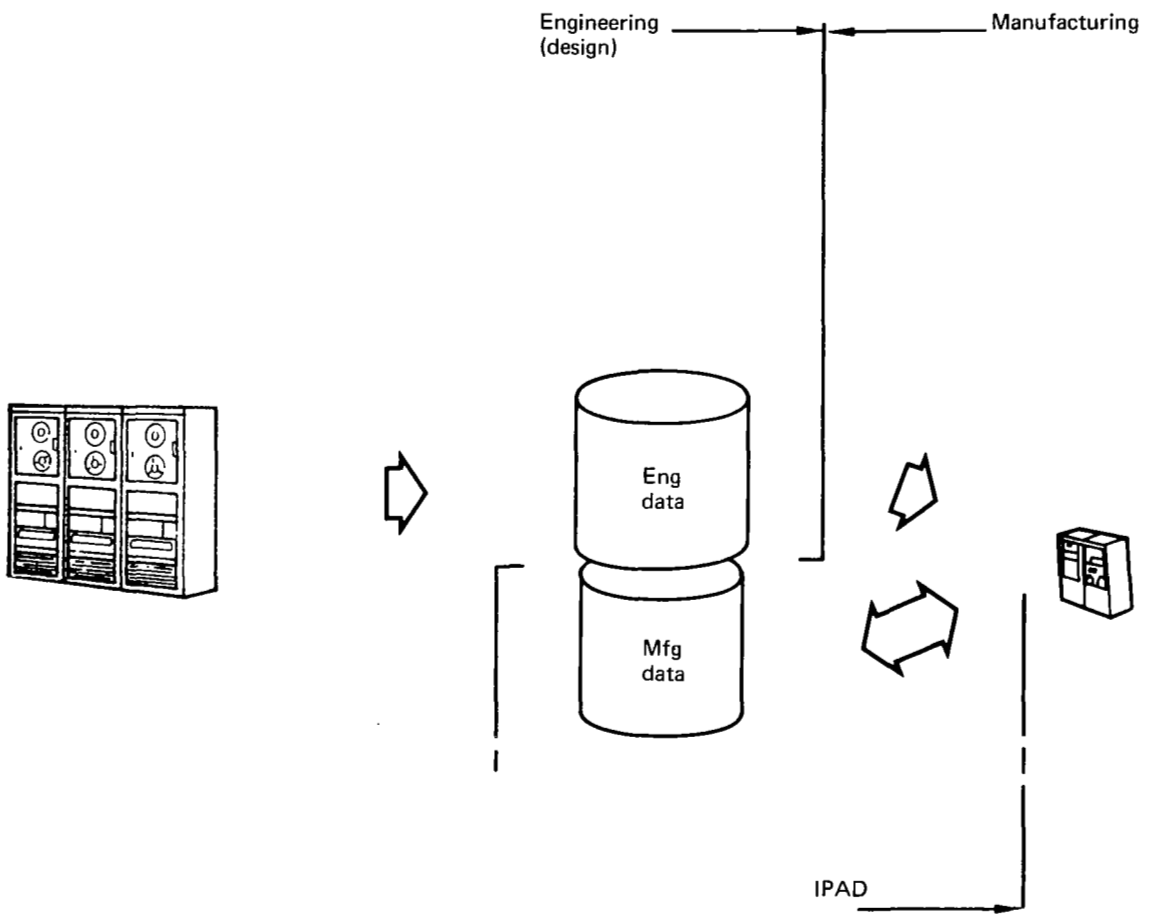

Figure 29.—Translated Storage

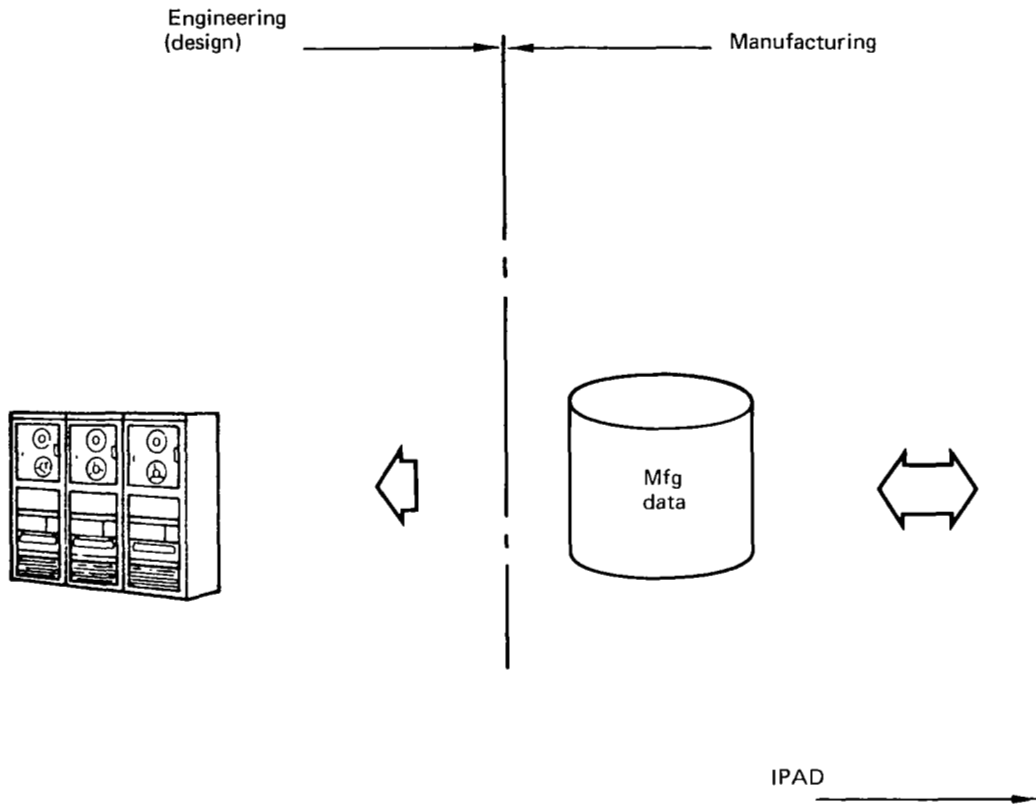

Figure 30.—Manufacturing Information for Design Support

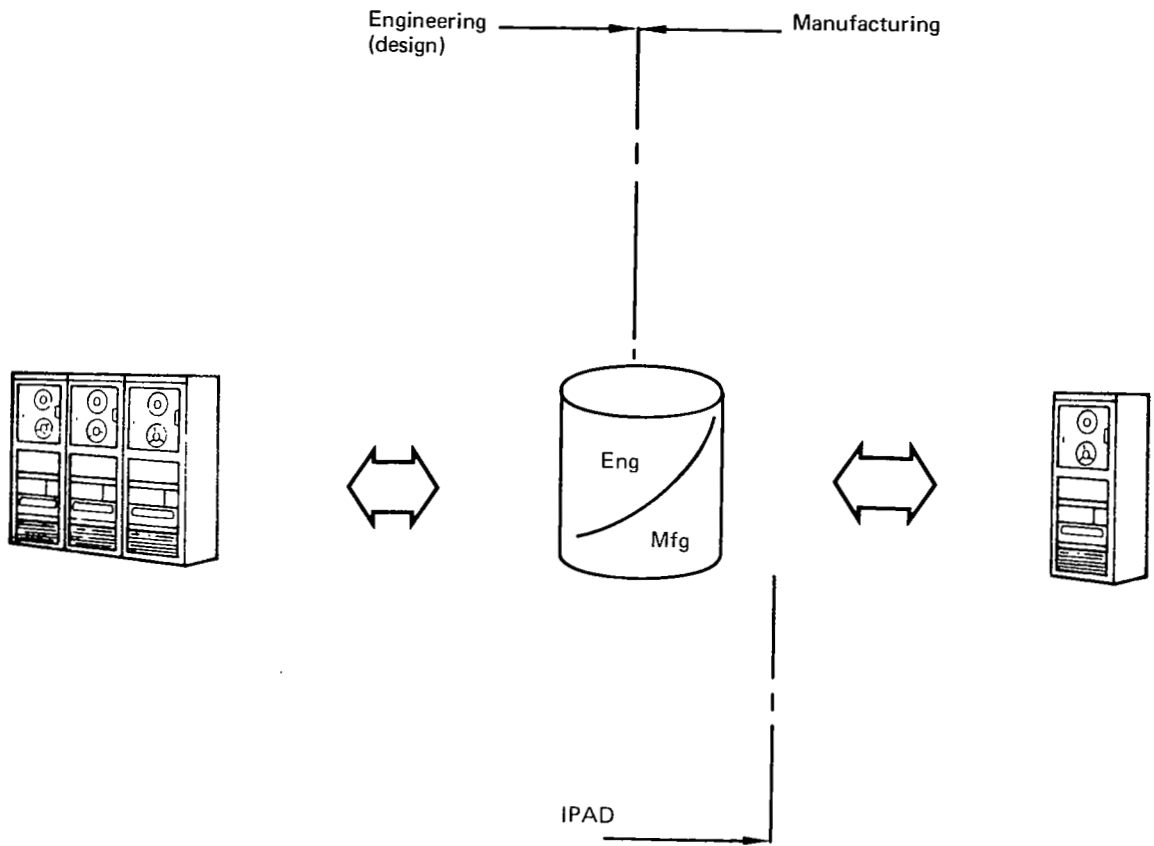

Figure 31.—Shared Data

the available computer power is to make sure their requirements are known and considered by system designers and implementers. In other words, get the potential users involved in the development of the systems on a day-to-day basis and keep them informed of the progress with periodic status reports.

Support requirements for manufacturing engineering, tool engineering, NC programming and quality control have been discussed in section 6.2. Additional considerations for support are discussed here.

6.4.1 MANAGEMENT INFORMATION

The work breakdown structure (WBS) is the common instrument used to estimate and collect costs and schedule fabrication of the product. The IPAD system must provide the means to monitor cost and schedule status, i.e., actuals versus targets. Additionally, the costs of using IPAD (session costs, accumulative costs weekly, monthly, etc.,) and identification of users must be accessible.

6.4.2 CONFIGURATION MANAGEMENT

The manufacturing user of design information, whether designing tools or verifying part fabrication, must know that the information used is valid; he must also know whether it has been changed. Design changes can be negotiated and the impact determined more efficiently in the IPAD environment. The user must be able to respond immediately to order material, rework tools, suspend fabrication orders, and revise manufacturing process paperwork.

6.4.3 USER ENVIRONMENT

The manufacturing IPAD user must be able to use the system in the same manner as the designer user. For the most part, this user will be accessing design information for use in a local system; he must also be able to enter data where it is needed. For example, the design engineer requires information concerning preferred methods of fabrication and assembly, fabrication costs, and shop processes. There should also be provision for system-to-system interfaces for the transfer of released design information to the production process systems. The manufacturing user must be able to interact at the terminal with other IPAD users.

6.4.4 INDUSTRIAL ENGINEERING

The industrial engineer requires the cost and schedule information in order to monitor actuals versus estimated costs. He requires design release information in order to schedule the work through the shops, and he must also schedule production changes.

6.4.5 MANUFACTURING COST DATA

It has always been realized by the manufacturing engineer that the design of a part should consider the cost of producing it equal in importance to its functional ability. DOD Directive 5000.28 supports this in stating design-to-cost objective: "to establish cost as a parameter equal in importance with technical requirements and schedules throughout the design, development, production, and operation of weapon systems, subsystems and components."

It is, therefore, necessary that information required by engineering concerning producibility constraints receive consideration in the IPAD data base equal to other factors required in the design of an aerospace product. (See fig. 32.)

Although all companies have top cost models, capabilities are limited in that they are at a high level and cannot be used for low-level cost trades. To obtain information at a detailed level usually requires direct interaction with manufacturing. This is usually slow, cumbersome, and normally inaccurate, as response is expected quickly. Many program decisions that should be based on accurate detail information are presently committed with insufficient data available. Cost avoidance information, to be most useful, must be available prior to drawing preparation. To make cost trades necessary in the decision-making process requires cost predictions. These must be accurate if a design support decision is to be made. If the cost data is inaccurate, the wrong decision will be made.

For effective manufacturing cost data to be available to engineering, programs will be required to ensure proper use of the information. The requirements will include:

- Establishment of an accurate cost and configuration data baseline

- Means of identifying high cost drivers early in the program

- Formal record of all tradeoff data

- Close cost tolerances to minimize program cost and profit risks

The availability of this information will enable the designer to understand how design affects cost, to iterate design concepts, and to develop alternates.

MINIMUM STANDARD INSIDE BEND RADII								
Thickness	ALUMINUM ALLOY - SERIES AND TEMPER							
	1100-0 2219-0 3003-0 5052-0 6061-0	2024-0 2219-T42 3003-H14 5052-H34 6061-T4	2219-T31 2219-T37	7075-0 7178-0	2024-T3 2024-T4 2219-T62 2219-T81 6061-T6	2024-T36 7075-T6 7178-T6	2024-T86 2219-T87	2024-T3 - Laminate
.016 ①	.03	.03	.03	.03	.06	.09	.25	
.020	.03	.03	.06	.03	.06	.09	.25	
.026	.03	.06	.06	.06	.09	.12	.31	
.032	.03	.06	.06	.06	.12	.16	.44	
.036	.06	.06	.09	.06	.16	.19	.50	.09
.040	.06	.06	.09	.06	.16	.19	.56	.16
.045	.06	.09	.12	.09	.19	.25	.62	.19
.050	.06	.09	.12	.09	.19	.25	.62	
.056	.06	.12	.16	.12	.22	.28	.62	.22
.063	.06	.12	.16	.12	.22	.31	.62	
.071	.09	.16	.19	.19	.28	.38	.75	
.080	.09	.16	.19	.19	.34	.44	.88	
.090	.12	.25	.34	.25	.44	.56	1.00	
.100	.12	.25	.50	.34	.56	.75	1.12	
.112	.12	.25	.50	.56	.75	.88	1.25	
.125	.12	.34	.62	.62	.88	.88	1.25	
.140	.16	.38	.69	.75	.88	.88	1.25	
.160	.19	.44	.75					
.180	.19	.50						
.190								

① Or less

Figure 32.—Sample of Manufacturing Information to Design

APPENDIX A

MANUFACTURING ORGANIZATION

The broad scope of which manufacturing is a part is sometimes called operations, which encompasses procurement, quality control, and facilities in addition to manufacturing. In this project organization description, we have represented manufacturing and quality control as functions and have included procurement under manufacturing with manufacturing engineering, industrial engineering, tooling, and factory. Quality control includes tool inspection, factory quality control, receiving inspection, source inspection, and data and software certification. There is a corporate research and development function, as well as the facilities organization, supporting each project. (Fig. 33).

The functions of the manufacturing organizations shown in figure 33 are described here to provide a reference to the manufacturing events in section 4.0.

A.1 MANUFACTURING

The basic function of the manufacturing organization is to fabricate the product to the design and Government/customer specifications within the established schedule and cost parameters. Manufacturing is broken down into functional groups that are responsible for specific operations during the fabrication process. These are described below.

A.1.1 MANUFACTURING ENGINEERING

Manufacturing engineering is a network of organizations that interpret, maintain, and control production requirements for an aerospace product. These organizations are:

A.1.1.1 Tool and Production Planning

Interprets design specifications and provides planning necessary to support fabrication of parts and tools.

A.1.1.2 Production Control

Maintains total fabrication requirements; makes commitments for spares; schedules and issues shop orders. Maintains mechanized order location, work in process status control, and inventory control on completed parts. Receives, stores, and issues parts required for assembly operations. Stores and issues contract tools.

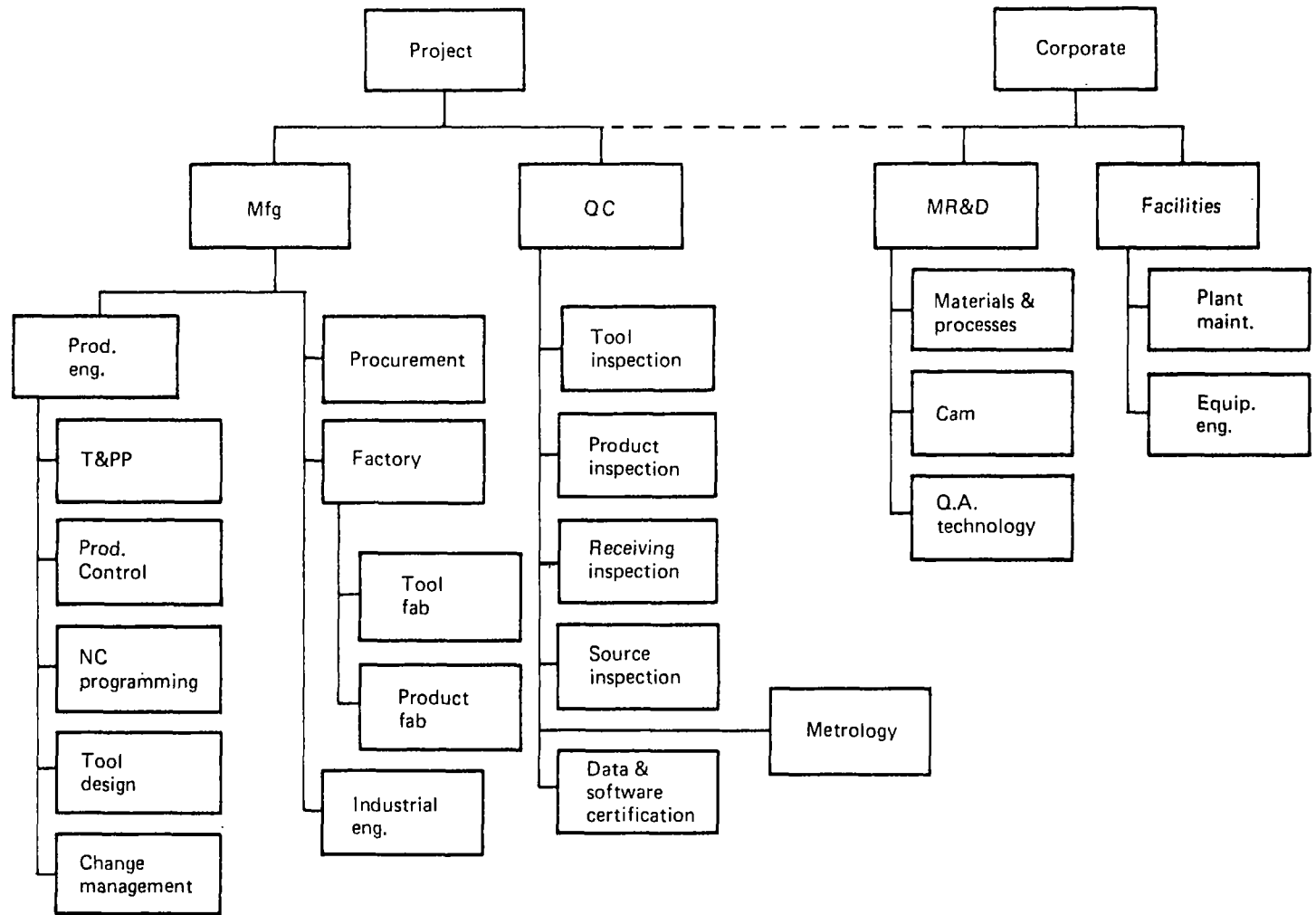

Figure 33.—Manufacturing Organization

A.1.1.3 Numerical Control Programming

Prepares control media for NC production of machined parts, tools, assemblies, and wire bundles.

A.1.1.4 Tool Design

Prepares designs and specifications for contract tools to support detail and assembly production operations, in accordance with tool orders from tool and production planning. Orders tool fabrication.

A.1.1.5 Change Management

Coordinates and maintains status of product design changes using representatives from all applicable organizations.

A.1.2 PROCUREMENT

Materiel is responsible for procurement and inventory management of production raw material, castings and forgings, purchased equipment, and outside production. Materiel also provides source selection, program surveillance and expediting actions.

A.1.3 FACTORY

The factory operates and manages facilities and people to meet production requirements to support the planned delivery rates of the product. The factory is also responsible for maintaining schedule, cost, quality, and safety requirements. The following functions are included.

A.1.3.1 Tool Fabrication

Builds tools to specifications provided by tool design and production engineering.

A.1.3.2 Product Fabrication

A network of shops that fabricate machined parts, sheet metal details and subassemblies, wiring and systems components, major assemblies, and installations to produce the final product and related spare parts.

A.1.3.3 Mockup Operations

Fabricates and maintains various physical mockups to design specifications. Develops wiring and tubing and other requirements using the mockups. Prepares production illustrations to facilitate installation operations.

A.1.4 INDUSTRIAL ENGINEERING

Industrial engineering conducts work studies, establishes standards, determines optimum shop loads, and negotiates program schedules consistent with manufacturing capability.

Industrial engineering is responsible for optimum utilization of capital and manpower resources. It plans and implements workloads of factory units and defines manpower levels that can achieve workloads within prescribed cost and schedule parameters.

A.2 QUALITY CONTROL

Quality control has the responsibility to assure that the design and other applicable requirements are met. Specific functions organized to accomplish this responsibility are:

A.2.1 TOOL INSPECTION

Tool inspection ensures that tools are fabricated to meet design specifications and that the tools function properly.

A.2.2 PRODUCT INSPECTION

Throughout the fabrication process, product inspection is responsible to verify that the product is built per design specifications. Maintains inspection records that become part of the documentation delivered to the customer.

A.2.3 RECEIVING INSPECTION

Receiving inspection verifies that purchased items and outside production components meet the purchase order specifications.

A.2.4 SOURCE INSPECTION

Source inspection maintains inspection operations at sources of outside production fabrication.

A.2.5 DATA AND SOFTWARE CERTIFICATION

This function determines that geometry data from computer systems, used by manufacturing and subcontractors, is valid.

A.2.6 METROLOGY

All measurement and test instruments and equipment are calibrated, certified, and repaired by the metrology laboratories.

A.3 RESEARCH AND DEVELOPMENT

While manufacturing and quality control are usually organized for each product line by project, the corporate office provides a manufacturing research and development (MR&D) organization that supports all product lines. MR&D provides continuous support to test and develop processes for new materials and design concepts and develops requirements for computer systems and quality assurance techniques. These may be broken down into:

A.3.1 MATERIALS AND PROCESSES

Processes are developed to support new materials introduced by design. New techniques are provided for production to improve fabrication and cut costs. The materials and processes organization troubleshoots production problems and develops solutions.

A.3.2 CAM DEVELOPMENT

Specifications for computer-aided systems are developed in support of all manufacturing organizations.

A.3.3 Q.A. TECHNOLOGY

Computer-aided technology specialists develop specifications and methods for computer-aided systems in support of quality assurance. They also develop improved inspection gages, equipment, test instruments and testing techniques.

A.4 FACILITIES

The facilities organization assures availability of applicable equipment for product fabrication, procures and installs new equipment, relocates existing equipment, manages

technical and budget requirements, and approves and prioritizes equipment requests and expenditures. Facilities designs, builds, and maintains company facilities and equipment.

APPENDIX B

GENERAL INTERFACES

The design/manufacturing interaction begins early in the conceptual stage of a new product and continues throughout the design and production processes.

The following paragraph was extracted from an October 1973 report by the Research and Engineering Advisory Committee of the National Security Industrial Association titled "Recommendations for Development of Major Defense Systems, DODD 5000 X."

"The engineering of complex defense systems is an interactive process of assuming solutions and proving them not the best; of trial and error; of testing hardware, of refining analyses, of correcting design, etc.; and of compromising a myriad of conflicting objectives into a product that will satisfactorily perform at an acceptable cost. Design trade-offs require a reasonably flexible environment during development. Goals must be proven feasible and converted into firm requirements for production."

Figure 34 shows the evolution of a product from preliminary design to early production. Note that:

Large commitments of people and money occur in the CAD/CAM interaction region.

Communication increases in complexity and importance with time.

The number of people who communicate increases with time as different parts of the organization and people with different skills and viewpoints become involved.

The need for control of the design increases greatly at the CAD/CAM interface.

Choices are being made continuously during the shift from pure engineering to production.

Baseline information used by operating management originates here.

If we learn to do a better job in what we do now, this same knowledge can be used to create future opportunities.

Figure 35 shows the extensive cross-feeding and integration of information between design and manufacturing organizations from preliminary design through the first design changes. Figure 36

shows the steps in production where information again shuttles back and forth between groups. What is not shown in these figures is the varying form of the information as it is used. All of these steps and transformations introduce time and especially chances for error in handling the information (ref. 11.)

These interfaces, or lines of communication between CAD and CAM, have thus far been concerned with transmitting engineering part definitions to manufacturing engineering in a manner that can be used efficiently. The trend has been to supply geometric definitions of parts where it is felt that tooling personnel or NC programming can best make use of the data in this form. Unfortunately, this is only one of the lines of communication between the two organizations, and it is presently not widely used.

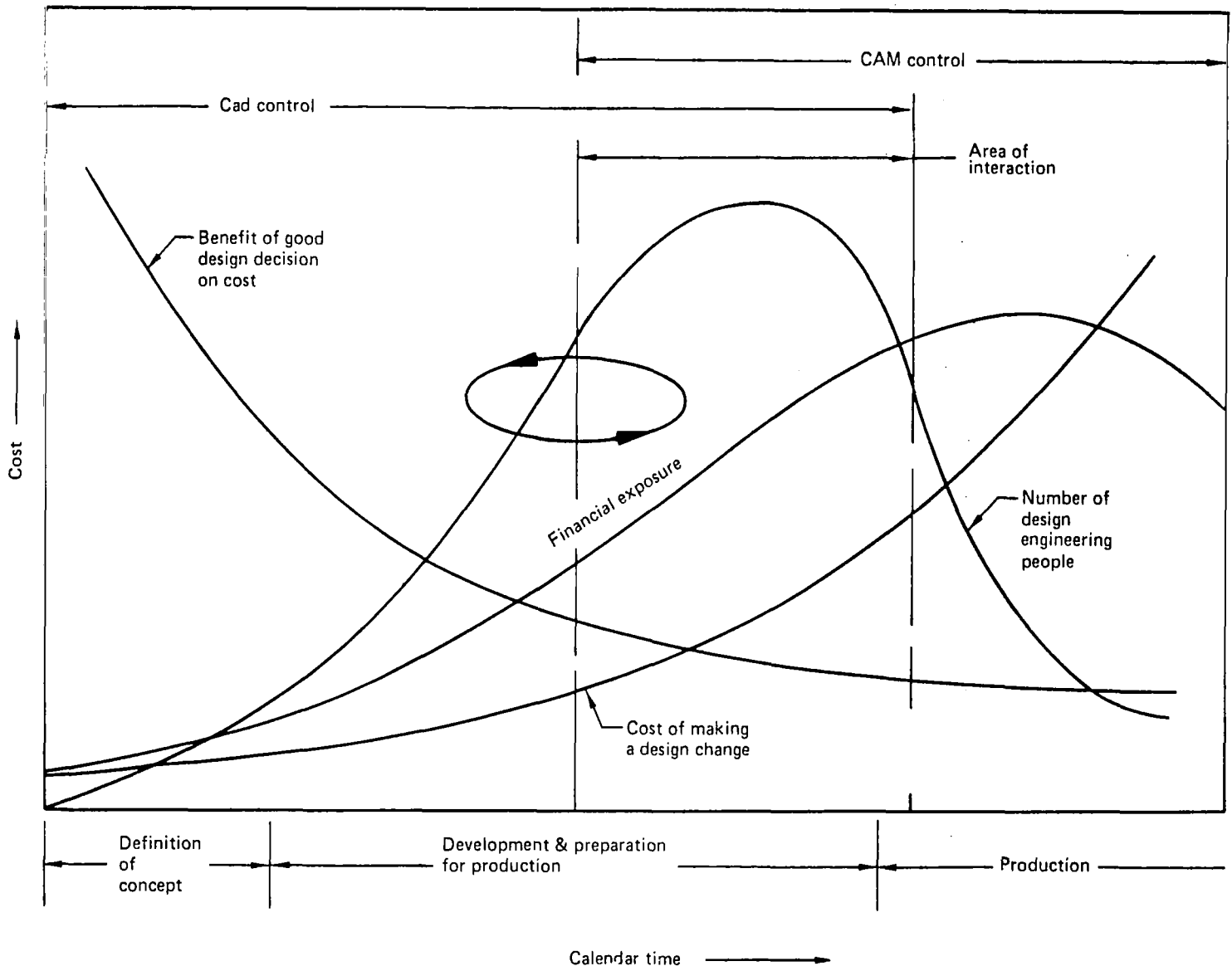

Figure 34.—CAD/CAM Control

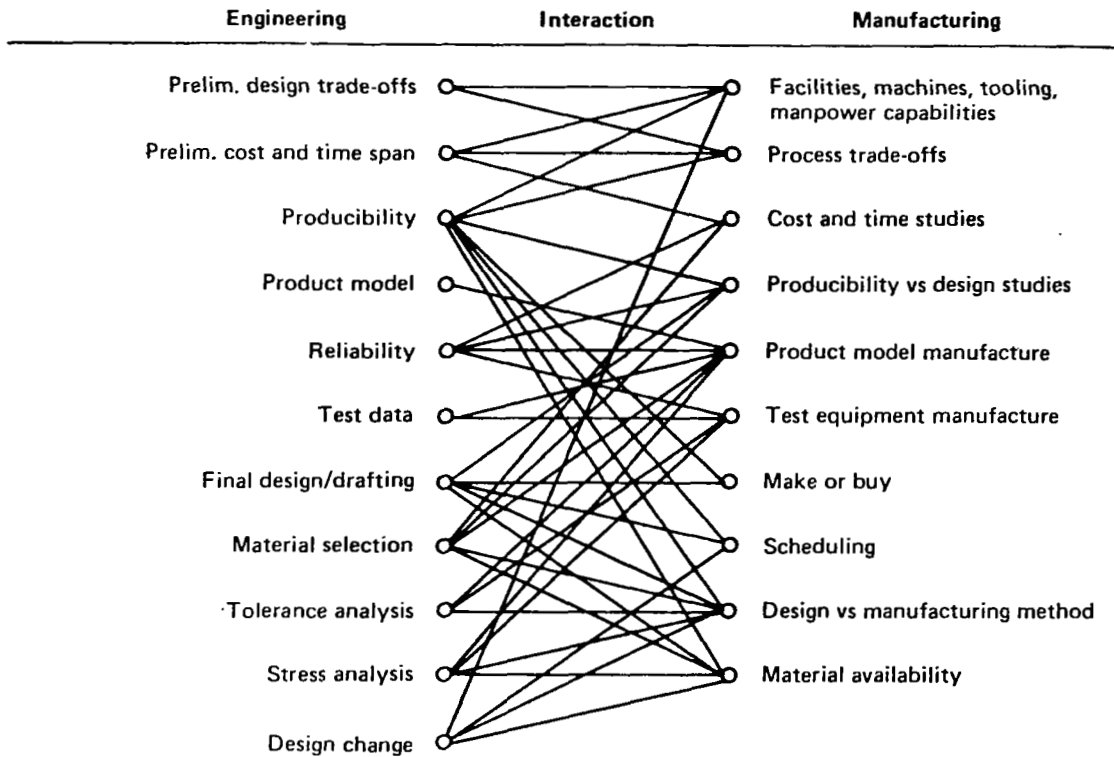

Figure 35.—Engineering-Manufacturing Interaction

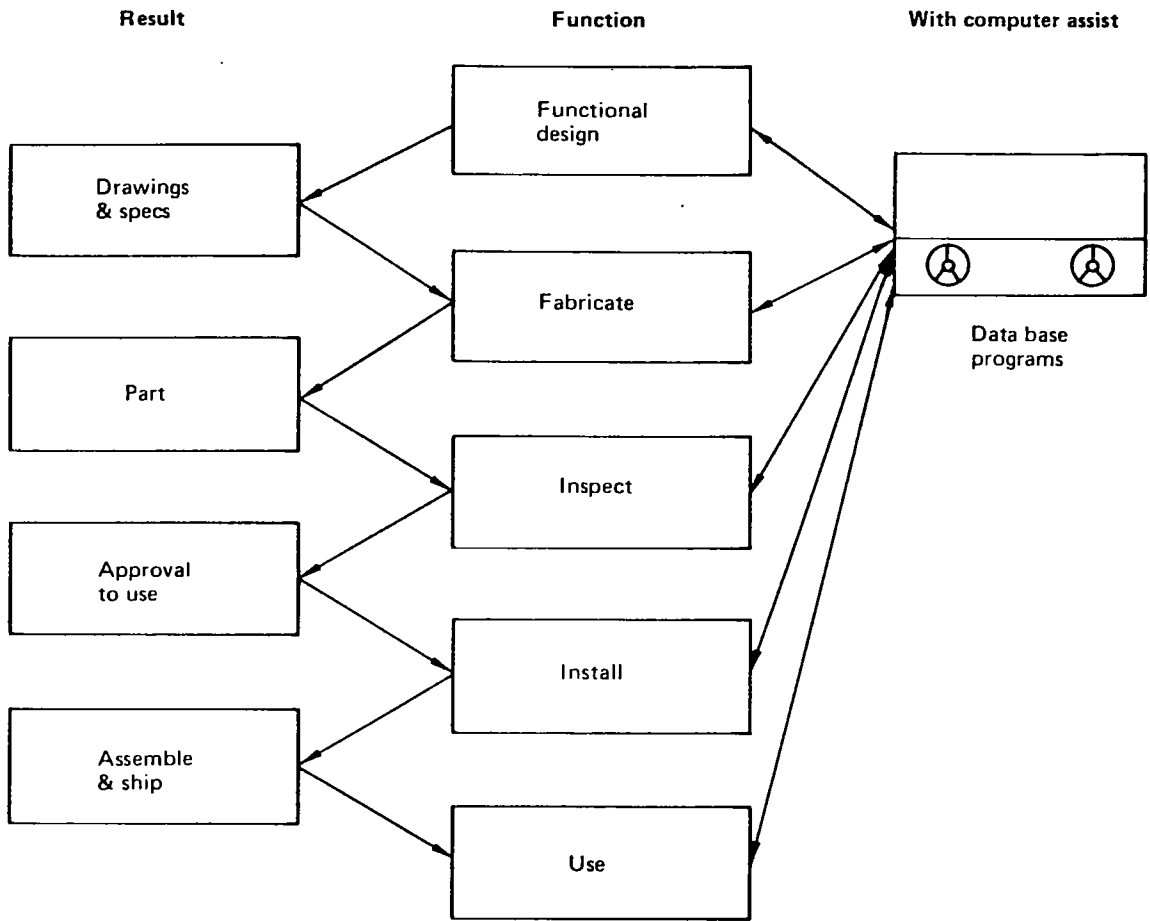

Figure 36.—Product Evolution

The following interfaces are identified and described individually in a format that emphasizes the important aspects as to intent, control, and distribution (ref. 11).

Interface	- Engineering Drawing
General Description	- The graphic and/or alphanumeric definitions for configuration control
Typical Information	- Dimensions, tolerances, material, geometry, manufacturing processes, specifications, loft data, etc.
Data Source	- Product design engineering (other areas of test and experimental not included)
Control	- Engineering release
Typical Distribution	- Manufacturing engineering, quality control, purchasing, tool design, numerical control, tool/part fabrication, etc.
Form of Data	- Graphic and alphanumeric
	* * * *
Interface	- Parts List
General Description	- The official configuration control document prepared by a design activity which identifies the components of a product
Typical Information	- Quantity, material, specifications, used on, drawing number, make-or-buy, processes, etc.
Data Source	- Product design engineering
Control	- Engineering release
Typical Distribution	- Manufacturing engineering, production control, purchasing, tool design, numerical control
Form of Data	- Alphanumeric
	* * * *

Interface	- Master Layout
General Description	- Graphic configuration control
Typical Information	- Shape, size, intersections, cross-sections, flat pattern projections, detail parts and assemblies
Data Source	- Product design engineering
Control	- Engineering release
Typical Distribution	- Manufacturing engineering, numerical control, tool design, shop operations, quality control, etc.
Form of Data	- Graphic
	* * * *
Interface	- Specification
General Description	- Specific engineering descriptions to control the configuration and quality of a part or product
Typical Information	- Test requirements, processes, performance characteristics, methods of assembly, procedures, reference documentation, etc.
Data Source	- Material and process research, government, industry, quality control, etc.
Control	- Engineering release, library sources, etc.
Typical Distribution	- Manufacturing engineering, shop operations, quality control, etc.
Form of Data	- Graphic and alphanumeric
	* * * *
Interface	- Engineering Design Standard (manufacturing use)
General Description	- Established and documented information for control of manufacturing processes and fabrication

Typical Information	- Design criteria
Data Source	- Product design engineering
Control	- Engineering release
Typical Distribution	- Manufacturing engineering, factory operations, quality control, etc.
Form of Data	- Graphic and alphanumeric
	* * * *
Interface	- Design Change Notice
General Description	- Design notification of scheduled product change to be incorporated into manufacturing cycle
Typical Information	- Part number, effectivity, description of change (graphic and/or alphanumeric), retrofit instructions (rework of existing details), etc.
Data Source	- Product design engineering
Control	- Engineering release
Typical Distribution	- Production planning, purchasing, tool design, numerical control, shop operations, etc.
Form of Data	- Graphic and alphanumeric
	* * * *
Interface	- Part Specification File
General Description	- Data file containing a complete geometric and alphanumeric description of a component (same data as product design drawing and parts list)
Typical Information	- Component geometric definitions, dimensions, tolerances, views and sections, material description, specifications, process notes, identification, next assembly, a history of design changes (see

product design drawing and parts list)

Data Source	- Product design engineering
Control	- Product design engineering
Distribution	- Purchasing, manufacturing engineering, factory operations, quality assurance, (by use of various application programs)
Form of Data	- Alphanumeric and graphic (by use of application programs)
	* * * *
Interface	- Substitute Design Authorization (SDA)
General Description	- Graphic and alphanumeric definitions of substitute design, and effectivity
Typical Information	- Part name, part number, effectivity, contract number, SDA reason, material, substitute design (including dimensions, tolerances, material, geometry, specifications)
Data Source	- Product design, liaison engineering, purchasing
Control	- Liaison engineering
Typical Distribution	- Manufacturing engineering, quality assurance, purchasing, factory operations, product design, liaison engineering
Form of Data	- Alphanumeric and graphic
	* * * *
Interface	- Quality Assurance Report (QAR)
General Description	- Alphanumeric definitions of discrepancy and disposition
Typical Information	- Component name and number, reference operation number, serial and work

	order numbers, discrepancy, disposition, effectivity
Data Source	- Quality assurance, liaison engineering, purchasing
Control	- Quality assurance
Typical Distribution	- Purchasing, liaison engineering, quality assurance, manufacturing engineering, factory operations
Form of Data	- Alphanumeric
	* * * *
Interface	- Advance Material Release (AMR)
General Description	- Alphanumeric definition of material needed in advance of normal availability schedule
Typical Information	- Material description using drawing, need date, quantity, justification, suggested vendor
Data Source	- Product design
Control	- Product design
Typical Distribution	- Product design, purchasing, manufacturing engineering
Form of Data	- Alphanumeric
	* * * *
Interface	- Aircraft Surfaces
General Description	- Data file containing geometric description of aircraft lofted surfaces
Typical Information	- Surface identification, canonical form of definition, history, aircraft type and effectivity
Data Source	- Advance design engineering
Control	- Product design engineering

Distribution	- Product design engineering, manufacturing engineering, quality assurance (by use of various application programs)
Form of Data	- Alphanumeric and graphic (by use of application programs)
	* * * *
Interface	- Engineering Production Release
General Description	- The authority to produce a part or a product
Typical Information	- Year of release, effectivity, etc.
Data Source	- Engineering release
Control	- Engineering release
Distribution	- Production planning procurement, tool design, NC programming, shop operation, etc.
Form of Data	- Alphanumeric
	* * * *
Interface	- Material Release Drawing
General Description	- The graphic and/or alphanumeric description of the material to be ordered
Typical Information	- Dimensions, tolerances, type of material, specifications, etc.
Data Source	- Product design
Control	- Engineering release
Distribution	- Production planning, procurement, tool design, NC programming, shop operation, etc.
Form of Data	- Graphic and alphanumeric

	* * * *
Interface	- Request for Design Change (to facilitate Manufacturing)
General Description	- Same as interface
Typical Information	- Graphic and/or alphanumeric description of request
Data Source	- Production planning, procurement, tool design, NC programming, shop operation, etc.
Control	- Engineering/manufacturing liaison
Distribution	- Product design
Form of Data	- Graphic and alphanumeric
	* * * *
Interface	- Computer Files
General Description	- The collection of storage of information
Typical Information	- Identification, accounting, definitions, programs, etc.
Data Source	- Engineering, manufacturing engineering, shop operation, quality assurance, etc.
Control	- Data source
Distribution	- As required
Form of data	- Alphanumeric
	* * * *
Interface	- Stop Orders/Stop Removal
General Description	- The stoppage of authority to produce a product/the listing of Stop
Typical Information	- Date, part identification, etc.
Data Source	- Engineering release
Control	- Engineering release

Distribution	- Production planning, procurement, tool design, NC programming, shop operation, etc.
Form of Data	Alphanumeric
	* * * *
Interface	- Mockup or Modeling
General Description	- The construction of the initial configuration of a product
Typical Information	- Feasibility
Data Source	- Development engineering
Control	- Development engineering
Distribution	- As required
Form of Data	- Graphics

APPENDIX C

AEROSPACE INDUSTRIES ASSOCIATION (AIA)

The Aerospace Industries Association of America, Inc. (AIA) is the national trade association of U. S. companies presently engaged in the research, development, and manufacturing of aerospace products (ref. 12). AIA traces its history to the Aeronautical Chamber of Commerce, which served diverse aeronautical interests in addition to airframe manufacturers. The organization functioned under the Chamber from 1919 until 1945, when industry growth and development dictated establishing the Aircraft Industries Association. In 1959, the Association was renamed the Aerospace Industries Association to reflect the industry's additional efforts in space vehicles and missiles as well as its continuing activities in aircraft design and production.

Activities of this voluntary trade organization are administered by an experienced professional staff under the direction of a General Manager, who receives policy guidance from the Board of Governors elected from the membership. Current membership of AIA includes 49 aerospace manufacturing companies.

There are nearly 1,000 company representatives on AIA committees, plus additional specialists on panels and task groups. These company representatives provide an effective means through which the industry can be informed of new government directives or policies or can quickly be polled to establish industry positions. (See fig. 37 for AIA organization.)

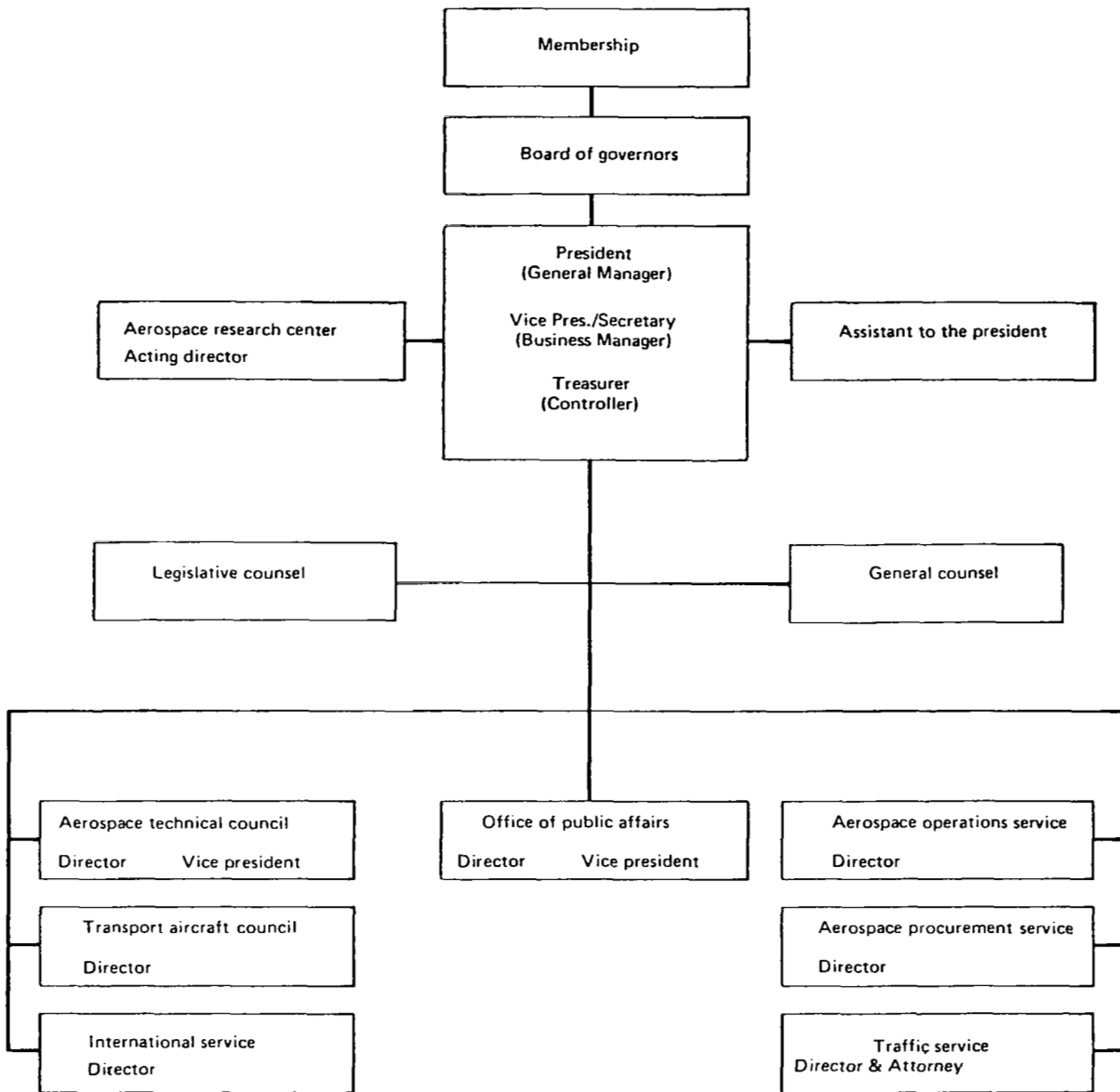

Figure 37.—Organization Chart

C.1 OBJECTIVES AND SCOPE OF MANUFACTURING COMMITTEE--AIA

The objective of the Manufacturing Committee is to provide a single authoritative source for obtaining, coordinating, and presenting aerospace product manufacturers' views on noncompetitive common problems affecting manufacturing. Further, the Committee assumes the functions and responsibilities of maintaining awareness, instituting industry and government coordination, providing advise and assistance to member companies, and otherwise monitoring all matters of mutual interest to member companies that are within the scope of manufacturing.

Areas within the scope of this Committee include machine tools and manufacturing equipment, facilities for manufacturing operations, product tooling functions, manufacturing processes, manufacturing test equipment, preservation and packaging of manufactured products, industrial environmental quality, and maintenance functions required for factory equipment and facilities. In addition, coordination is maintained with other AIA committees to avoid duplication of effort.

C.2 HOW CAM-1 IS ORGANIZED (ref. 13)

The policies and activities of CAM-I are directed by its members through the Board of Directors. These members meet annually to elect the Board, which in turn elects the officers of the corporation. A five-man Executive Committee is selected from the Board of Directors that includes all corporation officers. This Executive Committee manages affairs between full Board meetings. (See fig. 38).

The working committees of CAM-1 are divided into areas: Standards, Library and Information, Nominating, Project Procedures and Technical Review, and Advanced Technical Planning Committees. Each of these committees has as its function the general supervision of its assigned area and coordination of any subcommittees that pursue special aspects of the committee's work. Each may have many task groups to study individual problems.

In addition to the above committees, there may be special committees that report directly to the Board of Directors. These ad hoc committees may deal with matters of special importance to the CAM-I Board of Directors and are usually of short duration (Legal, Constitution and Bylaws, Finance, etc.). In addition, the Executive Committee may act as an ad hoc committee on any special activity.

The officers of CAM-1 exercise powers delegated to them by the Board of Directors and the Bylaws in handling CAM-I's day-to-day affairs. The administrative work is delegated to the CAM-I Executive Secretary and General Manager, who answers directly to

the President of CAM-I. The Executive Secretary and General Manager serves as the full-time director of all CAM-I affairs and as the corporation Secretary and Secretary of the Board of Directors. He has direct supervision of development contractors, the U.S., Europe, and Japan offices, and maintains close liaison with special projects, legal services, CPA services, marketing sales, and promotional functions. (See fig. 39).

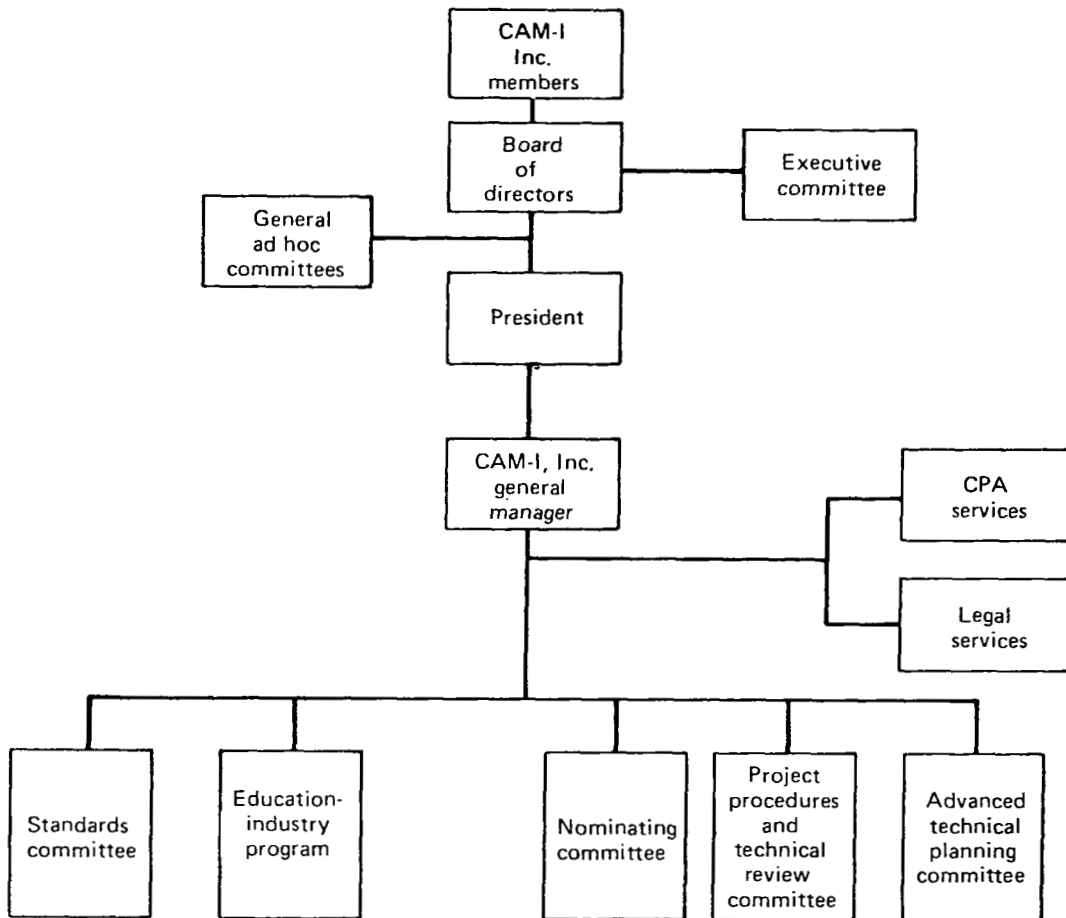

Figure 38.—CAM-I Membership Organizational Structure

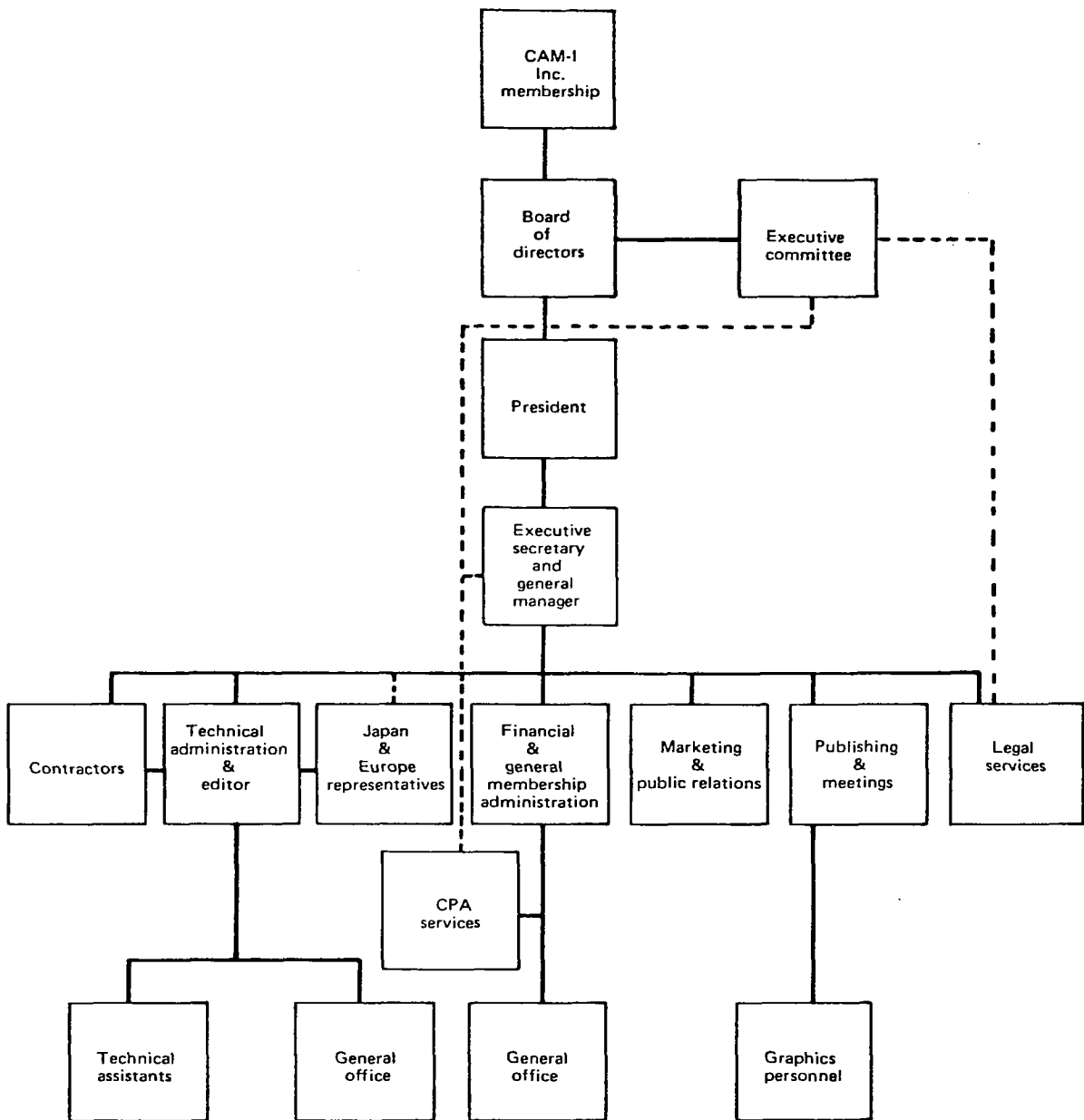

Figure 39.—Staff Organizational Structure

APPENDIX D

DEFINITIONS

Automatically Programmed Tools (APT) *

A computer-based numerical control programming system.

Computer-Aided Design (CAD)

Any computer system or program that supports the design of an aerospace vehicle; either "business" or "scientific" systems are included.

Computer-Aided Manufacturing (CAM)

Any computer system or program that supports the management and operation of a manufacturing facility (see CAD).

Computer Numerical Control (CNC) *

A numerical control system wherein a dedicated stored program computer is used to perform some or all of the basic numerical control machining functions.

Cathode Ray Tube (CRT) *

An electronic vacuum tube that can be used for display of graphic data.

Delphi Method

A procedural technique for technological forecasting; objective is to obtain a consensus of opinion regarding possible future events.

Distributed Numerical Control (DNC) *

An hierarchical association of computer-based support systems, the primary purpose of which is to provide machining data to machine control systems.

Integrated Computer-Aided Manufacturing (ICAM)

An Air Force program which is a follow-on to the AFCAM study.

Interactive Computer Graphics (ICG)

A computer-based system that allows the user to generate and manipulate two and three dimensional geometry at a terminal.

Macro

A preprogrammed set of instructions used by an NC programmer for repetitive operations.

Numerical Control (NC)*

Automatic control of a process performed by a device that makes use of all or part of numerical data generally introduced as the operation is in process.

Part Number (P/N)

An alphanumeric code assigned to discrete parts, assemblies and installations for identification through the manufacturing process.

Return on Investment (ROI)

An economic parameter used to assess viability of an investment in equipment or computer system development.

* Taken from National Aerospace Standard (NAS) 972 Glossary.

APPENDIX E

REFERENCES

1. Feasibility Study of an Integrated Program for Aerospace Vehicle Design (IPAD), The Boeing Company, Contract NAS1-11441, 1973 NASA CR 132390-97.
2. Computer-Aided Planning, Report to the AIA Manufacturing Committee, Project MC 74.5, October 1974.
3. Direct Numerical Control (DNC)/Computerized Numerical Control (CNC), Report to the AIA Manufacturing Committee, Project MC 74.2, October 1974.
4. Efficient Machine Loading & Scheduling, Report to the AIA Manufacturing Committee, Project MC 74.3, September 1974.
5. Aerospace Fibers Score High in Sports, Business Week, August 9, 1976.
6. Evans, Lary; Production Technology Advancements: A Forecast to 1988; Industrial Development Division, Institute of Science and Technology, The University of Michigan; 1973.
7. Buffum, H. E., "Air Force Computer-Aided Manufacturing (AFCAM)," Volume 5, Data for Module Development, Report AFML-TR-74-104, Air Force Materials Laboratory, WPAFB; Contract to Boeing; July 1974.
8. "CAD/CAM's Future: A Viewpoint," American Machinist, January 1976.
9. Design/Manufacturing Interface, Report to the AIA Manufacturing Committee, Project MC 74.4, October 1974.
10. Steiner, J. E.; "The Technology and Economics of Commercial Airplane Design;" the Swedish Society of Aeronautics and Astronautics, Stockholm, Sweden; November 8, 1972.

1. Report No. NASA CR-2982	2. Government Accession No.	3. Recipient's Catalog No.	
4. Title and Subtitle Product Manufacture Interactions with the Design Process		5. Report Date March 1979	6. Performing Organization Code
		8. Performing Organization Report No. D6-IPAD-70011-D	
7. Author(s) H. A. Crowell		10. Work Unit No.	
9. Performing Organization Name and Address Boeing Commercial Airplane Company P. O. Box 3707 Seattle, Washington 98124		11. Contract or Grant No. NAS1-14700	
		13. Type of Report and Period Covered Contractor Report	
12. Sponsoring Agency Name and Address National Aeronautics and Space Administration Washington, DC 20546		14. Sponsoring Agency Code	
		15. Supplementary Notes Robert E. Fulton, NASA IPAD Project Manager (Technical Monitor) Ralph E. Miller, Jr., Boeing IPAD Program Manager Topical Report	
16. Abstract <p>This document describes the product manufacturing interactions with the design process and the IPAD requirements to support the interactions. The data requirements supplied to manufacturing by design are described and quantified. Trends in computer-aided manufacturing (CAM) are discussed and the manufacturing process of the 1980's is anticipated. This document can be used with the Reference Design Process Document (D6-IPAD-70010-D) to provide an overview of the design process and its interactions with manufacturing.</p>			
17. Key Words (Suggested by Author(s)) Manufacturing process, computer-aided manufacturing (CAM), manufacturing technology, design manufacturing interactions, CAD/CAM trends		18. Distribution Statement Unclassified - Unlimited Subject Category 05	
19. Security Classif. (of this report) UNCLASSIFIED	20. Security Classif. (of this page) UNCLASSIFIED	21. No. of Pages 165	22. Price* \$8.00

*For sale by the National Technical Information Service, Springfield, Virginia 22151