

NASA Technical Paper 1459

Important Factors in the Maximum Likelihood Analysis of Flight Test Maneuvers

Kenneth W. Iliff, Richard E. Maine,
and T. D. Montgomery

APRIL 1979



LOAN COPY: RETURN
AFWL TECHNICAL LIBR,
KIRTLAND AFB, N. M.



LOAN COPY: RETURN TO
AFWL TECHNICAL LIBRARY
KIRTLAND AFB, N. M.

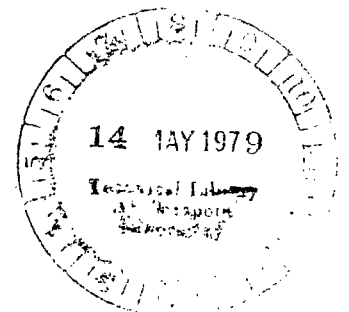



NASA Technical Paper 1459

Important Factors in the Maximum Likelihood Analysis of Flight Test Maneuvers

Kenneth W. Iliff, Richard E. Maine,
and T. D. Montgomery
*Dryden Flight Research Center
Edwards, California*

NASA

National Aeronautics
and Space Administration

**Scientific and Technical
Information Office**

1979

CONTENTS

	Page
INTRODUCTION	1
SYMBOLS	2
THE MAXIMUM LIKELIHOOD ESTIMATOR	4
OUTLINE OF FLIGHT DATA ANALYSIS EFFORT	6
Preflight Procedures	7
Basic Data Inspection	7
Data Preprocessing	7
Data Analysis	8
Summary Plots	8
INSTRUMENTATION	8
Signals Required	8
Data Quality	9
APPLICATIONS AND SPECIAL PROBLEMS	14
Turbulence	16
Structural Modes	18
Linear Dependence Problems	20
Time-Varying Systems	23
Nonlinearities	24
Cross Coupling	26
Estimation of Pitching Moment Due to Vertical Acceleration	30
CONCLUDING REMARKS	32
APPENDIX—DESCRIPTION OF MMLE 3 PROGRAM	34
REFERENCES	38

IMPORTANT FACTORS IN THE MAXIMUM LIKELIHOOD
ANALYSIS OF FLIGHT TEST MANEUVERS

Kenneth W. Iliff, Richard E. Maine, and T. D. Montgomery
Dryden Flight Research Center

INTRODUCTION

One of the primary goals of an aircraft flight test program is to estimate flight-determined aircraft characteristics, such as the aircraft's performance, structural, and stability and control coefficients. As these estimates become available during the flight test program, they can be used to expand the flight test envelope, update the simulators, and improve the aircraft propulsion and control systems. After the analysis of the flight test data, the estimated coefficients can be compared with calculated and wind-tunnel predictions, and the results of this comparison can be used to update prediction methods for the improvement of future aircraft design.

Some of the flight-determined coefficients can be obtained through an analysis that assumes static conditions (ref. 1). However, the required flight test time can sometimes be reduced by using dynamic maneuvers. In addition, many coefficients of interest cannot be determined from static tests. The analysis of dynamic maneuvers has required the application of new and more complex analysis techniques. One of the techniques that is widely used to analyze dynamic maneuvers is maximum likelihood estimation (refs. 2 to 6).

This paper discusses the application of a maximum likelihood estimator to dynamic flight data. The maximum likelihood estimator is described, the procedure for flight data analysis is outlined, instrumentation requirements and problems are discussed, and examples of applications and special problems are presented. The discussion emphasizes the estimation of stability and control derivatives because most of the estimation experience to date has been with these derivatives.

SYMBOLS

A, B, C, D	system matrices
a_n	normal acceleration, g
a_x	longitudinal acceleration, g
a_y	lateral acceleration, g
b	reference span, m
C_A	coefficient of axial force
C_D	coefficient of drag
C_{D_I}	coefficient of induced drag
C_L	coefficient of lift
C_ℓ	coefficient of rolling moment
C_m	coefficient of pitching moment
C_N	coefficient of normal force
C_n	coefficient of yawing moment
C_Y	coefficient of side force
c	reference chord, m
$f()$	general function
GG^*	power spectral density of measurement noise
g	acceleration due to gravity, m/sec ²
$g()$	general function
I_x, I_y, I_z, I_{xz}	inertias, kg-m ²

J	cost functional
K_α, K_β	flow amplification factors
L	normalized rolling moment, rad/sec^2
M	normalized pitching moment, rad/sec^2
m	mass, N
N	normalized yawing moment, rad/sec^2
n	state noise vector
p	roll rate, deg/sec or rad/sec
q	pitch rate, deg/sec or rad/sec
\bar{q}	dynamic pressure, kN/m^2
R	covariance of weighted residual measurement error
r	yaw rate, deg/sec or rad/sec
s	reference area, m^2
T	maneuver duration, sec
t	time, sec
u	input vector
V	velocity, m/sec
x	state vector
$x_{a_n}, x_{a_y}, x_\alpha, x_\beta$	distances of instruments forward of center of gravity, m
Y	normalized lateral force, rad/sec
y	observation vector
Z	normalized normal force, rad/sec
z	measured observation vector
$z_{a_x}, z_{a_y}, z_\beta$	distances of instruments below center of gravity, m

\hat{z}_ξ	Kalman-filtered estimate of the observation vector
α	angle of attack , deg
$\hat{\alpha}_g$	angle of attack induced by vertical velocity component of turbulence , deg
β	angle of sideslip , deg
δ	general control
δ_a	aileron deflection , deg
δ_e	elevator deflection , deg
δ_r	rudder deflection , deg
η	measurement noise vector
θ	pitch angle , deg
ξ	vector of unknowns
φ	bank angle , deg

Subscripts:-

m	measured
$p, q, r, \alpha, \dot{\alpha}, \beta, \delta, \delta_a, \delta_e, \delta_r$	derivative with respect to indicated quantity

trim trimmed value

0 bias

Superscript:

* matrix transpose

THE MAXIMUM LIKELIHOOD ESTIMATOR

The problem considered is: Given a set of flight time histories of an aircraft's response and input variables , find the values of some unknown parameters in the system equations that result in the best representation of the actual aircraft

response. An intuitive mathematical approach to the problem is to minimize the difference between the flight response and the response computed from the system equations. This difference could be defined for each response variable as the integral of the error squared. The differences could then be multiplied by weighting factors proportional to the relative confidence in each signal and summed to obtain the total weighted response error. This approach defines an integral-squared-error criterion.

A mathematically more precise probabilistic formulation can be made. For each possible estimate of the unknown parameters, a probability distribution for the noise-contaminated aircraft response can be defined based on the dynamic model. From each of these distributions, one can evaluate the relative likelihood that the noise-contaminated response will equal the response actually measured. Estimates are then chosen such that this likelihood is maximized. These estimates are referred to as the maximum likelihood estimates.

The general model for the dynamic systems is

$$\dot{x}(t) = f(x, u, t) + n(t) \quad (1)$$

$$y(t) = g(x, u, t) \quad (2)$$

$$z(t) = y(t) + \eta(t) \quad (3)$$

The noise is assumed to be zero mean, white, Gaussian, and stationary. The maximum likelihood estimates are obtained by maximizing the likelihood functional or, equivalently, by minimizing the following negative log likelihood functional (ref. 7):

$$J(\xi) = \frac{1}{T} \int_0^T (z - \hat{z}_\xi)^* (GG^*)^{-1} (z - \hat{z}_\xi) dt + \text{Trace } R \quad (4)$$

where \hat{z}_ξ is the Kalman-filtered estimate of y , and R is the covariance matrix of the weighted observation estimation error. This algorithm, in contrast to the extended Kalman filter method (ref. 8), uses the Kalman filter only to estimate the states and observations, not to estimate the unknown coefficients. When there is no state noise, R is the null matrix and \hat{z}_ξ is obtained by simply integrating the system equations; no linearity assumptions are required. If state noise is present, the system equations must be linear in order to rigorously define the likelihood functional as in equation (4). For nonlinear systems with state noise, an estimator can be defined by replacing the Kalman filter for \hat{z}_ξ with an extended Kalman filter, but such an estimate will not be maximum likelihood.

Figure 1 illustrates the maximum likelihood estimation concept. The measured response of the aircraft is compared with the estimated response, and the difference between these responses is called the response error. The Newton-Balakrishnan (ref. 7) computational algorithm (formerly referred to as the modified Newton-Raphson algorithm) is used to find the coefficient values that maximize the

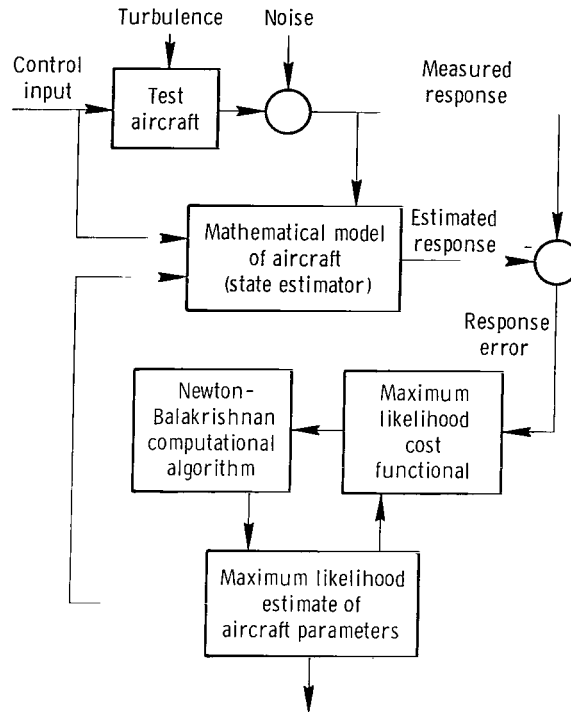

Figure 1. Maximum likelihood estimation concept.

likelihood functional. Each iteration of this algorithm provides new estimates of the unknown coefficients on the basis of the response error. These new estimates of the coefficients are then used to update the mathematical model of the aircraft, providing a new estimated response and, therefore, a new response error. The updating of the mathematical model continues iteratively until a convergence criterion is satisfied. The estimates resulting from this procedure are the maximum likelihood estimates.

The maximum likelihood estimator also provides a measure of the reliability of each estimate based on the information content of each dynamic maneuver. This measure of the reliability, analogous to the standard deviation, is called the Cramer-Rao bound (ref. 3) or the uncertainty level. The Cramer-Rao bound as computed by current programs should usually be taken as a measure of relative accuracy rather than absolute accuracy. Only recently (ref. 9) has insight been gained into the computation and interpretation of the absolute magnitude of the bound. When carefully used, the Cramer-Rao bound has proven to be a useful tool for assessing the validity of the estimates.

OUTLINE OF FLIGHT DATA ANALYSIS EFFORT

A multitude of problems can occur in the analysis of flight data, especially if the data processing is hasty and attempts to untangle problems and interpret results are

left until the end (ref. 3). However, with careful attention to detail at the appropriate times, the analysis can proceed smoothly and quickly enough to meet the requirements of the most demanding flight test schedules.

This section outlines a desirable procedure for the analysis of flight data. The outline does not include such special situations as the concurrent use and updating of a flight simulator. The procedure may change during the flight test program as the data system stabilizes and the expansion of the flight envelope begins.

Preflight Procedures

Before flight, the maneuvers and flight conditions are chosen, the details of the instrumentation systems are specified, and the basic analytical model is chosen. In planning a flight test program, one important point should be realized: Because of the nature of parameter identification, no single maneuver, no matter how carefully analyzed, can provide a definitive description of an aircraft or even of an aircraft at a given flight condition. This is true even when automatic tests for validity, such as the uncertainty levels, are available, because all such tests make certain *a priori* assumptions about the model. Thus, there is no substitute for obtaining several maneuvers at a single flight condition or a series of maneuvers that show a consistent trend as the flight condition changes. The purpose of the maximum likelihood estimation method is to prevent the flight time and the effort required to analyze these maneuvers from being prohibitive. The test pilot should be informed of the requirements for each maneuver and the reasons for these requirements. Keeping the pilot informed can improve the quality of the maneuvers, particularly if unexpected difficulties require innovations in flight. Getting the pilot's opinion of the feasibility of a given maneuver can also prevent wasted flight time.

Basic Data Inspection

During or after a flight, the raw data should be inspected for obvious data acquisition system problems. In addition, the analyst should make a quick check for violations of basic modeling assumptions such as mode coupling, varying flight conditions, or large bank angle excursions. If such problems are recognized in time, the maneuver can be repeated during the same flight.

Data Preprocessing

The flight data measured by the aircraft instrumentation must be recorded. The data should be digitized and converted to engineering units, then processed to remove data spikes and, if necessary, filtered to remove structural effects. Any effects of time skews in the recording system should be corrected at this point. Other preprocessing tasks, such as the computation of air data parameters from pressure data (ref. 10), should also be performed.

Data Analysis

At this point, a program for the analysis of dynamic maneuvers, such as MMLE (ref. 11) or MMLE 3 (see appendix), is run using the aircraft model selected previously. All the cases should be examined for problems, and fit errors and other abnormalities should be studied. Particular attention should be paid to whether any of the abnormalities observed may have been caused by violations of modeling assumptions. Suspected problems should be checked using external sources if possible (for instance, if the flight condition seems to be misidentified). Cases where rectifiable problems are identified should be corrected and rerun. This step should be repeated as necessary, depending on the urgency of the analysis, the economics of analyst and computer time, and the extent of the problems encountered.

Summary Plots

To examine the results, the derivatives and associated uncertainty levels should be plotted. Unexpected results should be studied to see if they have been caused by the misidentification of the flight condition, the improper specification of instrument location, or errors in the model or the data. If any significant errors are indicated, the data analysis should be redone; otherwise, the preliminary analysis is finished.

The emphasis of the procedure described in the previous sections is on the continual reevaluation of the modeling assumptions. When the analysis is finished, analysts often question only the data acquisition system or the maximum likelihood estimation method as obvious sources of difficulty, but they should also reexamine the modeling assumptions.

INSTRUMENTATION

This section discusses the data requirements for performing maximum likelihood estimation. A list of the signals required is presented, as well as a discussion of data quality considerations.

Signals Required

The signals required for maximum likelihood estimation fall into two partially overlapping classes. The first class consists of signals for which only an average value is required for each maneuver. The second class consists of signals for which the complete time history must be available. Some signals can fall in either class, depending on the particular maneuver.

Signals for which only an average value is required include those that define the vehicle configuration, flight condition, and mass characteristics. These signals need not be recorded on the data tape; pilot lap notes or similar hand-kept records

may be adequate in some cases. However, for large numbers of maneuvers, it may prove convenient to record these signals on the data tape in order to automate the bookkeeping.

The vehicle configuration includes the positions of all flaps, canards, landing gear, wings (sweep angle), engine controls, and other items that affect the aerodynamic characteristics of the vehicle and are held fixed during a maneuver. The flight condition is defined by velocity, altitude, Mach number, dynamic pressure, angle of attack, and other quantities used to nondimensionalize the derivatives or plot the results. Some flight test programs may only require the estimation of dimensional derivatives, in which case some of the nondimensionalizing parameters may not be necessary. The mass characteristics that should be known are the weight, center of gravity, and inertias. These mass characteristics are usually determined from tables based on vehicle configuration, fuel weight, and cargo loading. An accurate determination of the mass characteristics is essential, because errors in the mass characteristics result in proportional errors in the nondimensional derivatives. If feasible, the weight and inertias of the vehicle actually tested should be measured (ref. 12) and compared with calculated values. A frequently overlooked quantity is the vertical center of gravity position, the importance of which is discussed later in this report.

The signals for which time histories are most necessary are the positions of the controls that move during a maneuver and the response variables to be matched. For stability and control analyses where cross coupling is important (see Cross Coupling), the longitudinal response variables are needed to match the lateral responses, and the lateral response variables are needed to match the longitudinal responses. The longitudinal response variables are α , q , θ , a_n , a_x , and \dot{q} ; the lateral directional response variables are β , p , r , ϕ , a_y , \dot{p} , and \dot{r} . Measurements of \dot{p} , \dot{q} , and \dot{r} are often not available; however, differentiated values of p , q , and r should *not* be substituted as they add no new information and may even be detrimental. Not all the response variables must be measured for each maneuver, but the more that are available, the more reliable will be the derivative estimates.

In special situations, time histories are required for some of the normally constant signals. The most common example of this is the necessity for time histories of velocity and dynamic pressure if those signals change enough during a maneuver to have significant effects on the estimates. In general, any signal that changes enough during a maneuver to affect the analysis should be recorded as a function of time.

Data Quality

Two basic factors in data quality are the instrument resolutions and the sampling rates. Experience indicates that in general neither of these factors alone is critical (ref. 3). However, the additive effects of these and other factors can be significant. Fairly low resolution can be tolerated for any noncontrol signal if measurement noise is low. This is particularly true if many signals are used for time history matches and some of the signals have good resolution (ref. 9). A resolution of 1/10 of the maximum signal amplitude for a maneuver is about the minimum acceptable under ideal conditions. Resolutions on the order of 1/100 of

the maximum signal amplitude for a maneuver are preferred. If the data clearly define the aircraft response and no other data problems exist, the estimator can be expected to perform well.

Much the same conclusion can be drawn in regard to the sampling rate. For typical aircraft at typical flight conditions, sampling rates of 10 samples per second are often adequate for the analysis (refs. 13 and 14); however, problems can arise for aircraft with fast responses or for data resulting from rapid control inputs. Sampling rate requirements are also related to the duration of the maneuvers (ref. 14). As discussed later under Structural Modes, the sampling rate is often dictated by considerations other than the estimation procedure. Sampling rates as high as 200 samples per second are sometimes needed to filter out structural vibrations.

The maximum likelihood estimator is very sensitive to small time or phase shifts between parameters (ref. 15). Most data sampling techniques result in small time skews between parameters. For example, if data are sampled at 10 samples per second, the sample of one parameter may be separated by up to 0.1 second from the sample of another parameter in the same time frame of data. The maximum likelihood estimation algorithm assumes that all measurements in one time frame are sampled simultaneously, so any time shift causes errors in the estimated coefficients. The time shift becomes particularly important when the control input is sampled at a significantly different time than one or more of the response measurements within the sample interval. If time skews are unavoidable, the effect can be compensated for by time shifting the appropriate signals before the analysis is begun.

A phase shift due to instrumentation filters can cause a similar problem. All filter rolloff frequencies should be kept much higher than the aerodynamic frequencies of interest. If this is not possible, all the measurements should be filtered with the same filter, or phase shift corrections should be applied to the raw data for all the filtered measurements. Another possible source of time errors is the lag in the response of pressure instrumentation, particularly when long tubes are involved.

The effects of time and phase shifts in the flight data on the stability and control derivatives are documented in reference 15. An example from reference 15 of the effect on L_β of a time shift in p , β , or δ_a is shown in figure 2. The yaw rate, r , and lateral acceleration, a_y , were also used in the analysis, but they were not time shifted. The zero-shift value is assumed to be the correct value, and a positive shift indicates that all the other signals lead the shifted variable. As shown in the figure, shifts in p or δ_a have significant effects on the estimated value of L_β . A positive time shift of 0.1 second for δ_a results in a 50-percent error in L_β . A negative time shift of 0.1 second in p also results in a 50-percent error. Time shifts larger than 0.1 second have been observed in flight data. Reference 15 shows similar results for most of the stability and control derivatives of five aircraft, although the magnitude and direction of the effect of the shift on the derivatives are not necessarily the same as shown in figure 2.

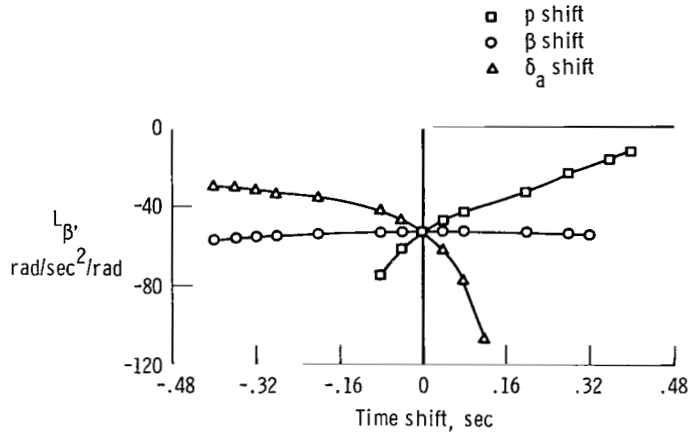

Figure 2. Estimated L_{β} as a function of time shift.

Instrument positions and angular orientations are important factors in analyzing flight data. There are usually no particular requirements on where the instruments must be, but it is important to know precisely where they are and how they are aligned in order to account for the effects of their displacement from the center of gravity or their misalignment from the body axes.

Knowing the positions of the accelerometers and the angle-of-attack and angle-of-sideslip vanes is particularly important. If these instruments are offset from the center of gravity, corrections can be made in the analysis. If the data are not corrected for vane location, the fit of the data will be poor, particularly when angular rates are high. If the data are not corrected for accelerometer position, some of the estimated derivatives ($C_{Y_{\beta}}$ and $C_{L_{\alpha}}$, in particular) will be affected.

If the correction for accelerometer position has not been made, it usually becomes evident when the measured and estimated data are compared. In figure 3(a), for example, the fit of the flight and estimated data for the 3/8-scale F-15 remotely piloted research vehicle (RPRV, ref. 16) for roll rate, p , is excellent, but there are some discrepancies in the fit of the data for a_y , particularly where \dot{p} is large. This is the type of mismatch that occurs if the accelerometer location is different from that assumed in the model. If a more precise determination of the location of the lateral accelerometer is made and included in the estimation process, a better fit results. The comparison that resulted when the assumed vertical location of the lateral accelerometer on the RPRV was changed by 15 centimeters (which corresponds to 40 centimeters on an F-15 aircraft) is shown in figure 3(b). The fit for a_y is much better and the fit for p is slightly improved.

It might be thought that such a small inconsistency would have an insignificant effect on the estimates of the derivatives. Figure 4(a) shows the coefficient $C_{Y_{\beta}}$ estimated with the accelerometer position assumed in figure 3(a); figure 4(b)

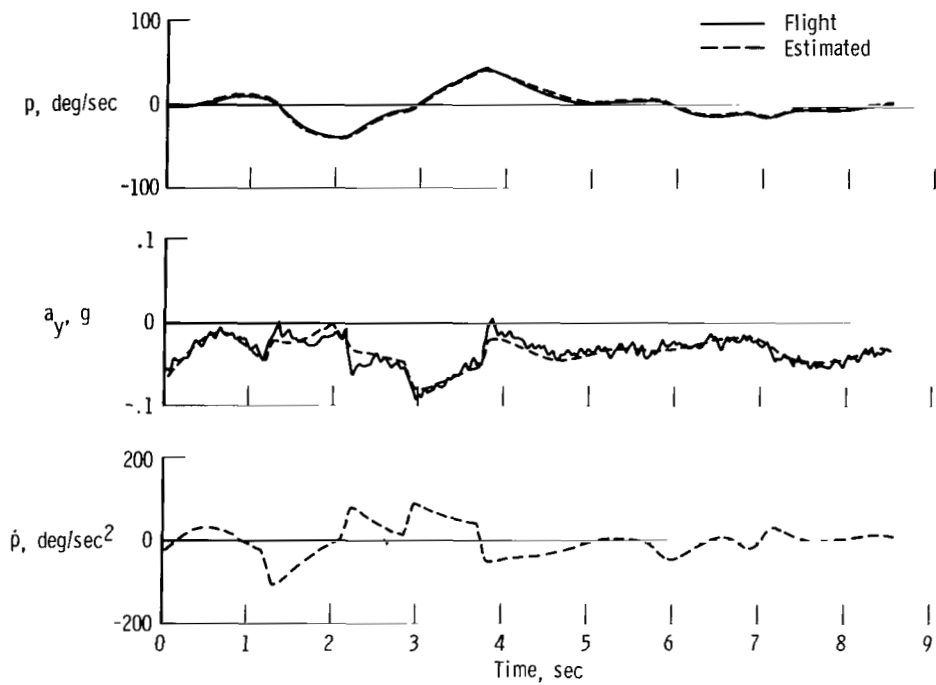

(a) *Incorrect accelerometer location.*

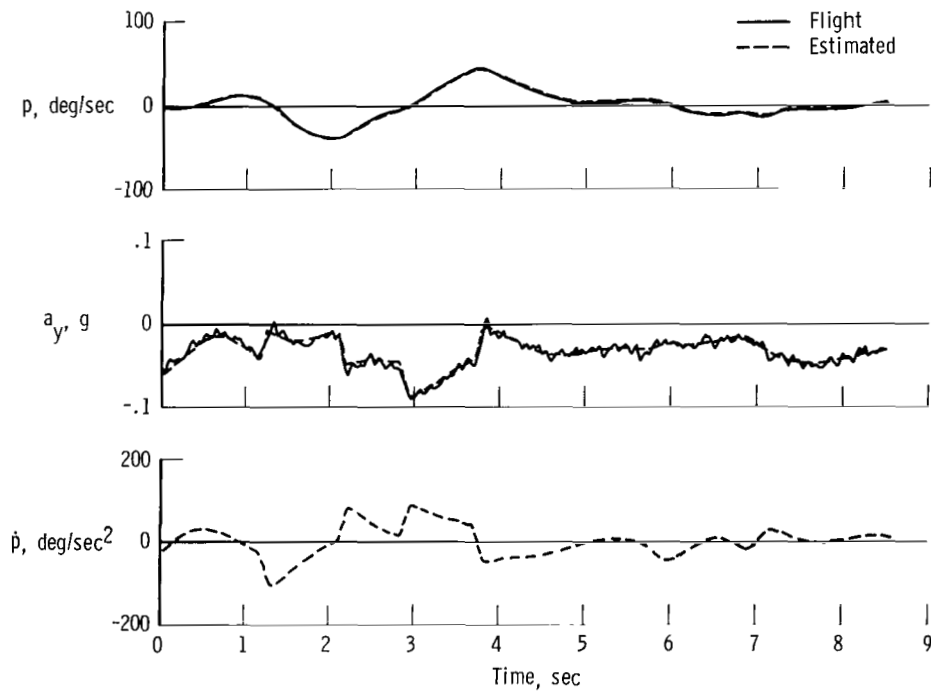

(b) *Correct accelerometer location.*

Figure 3. *Effect of assumed lateral accelerometer location on fit of flight and estimated data.*

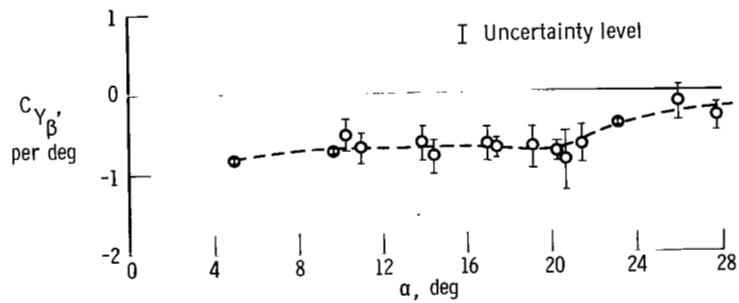

(a) *Incorrect accelerometer location.*

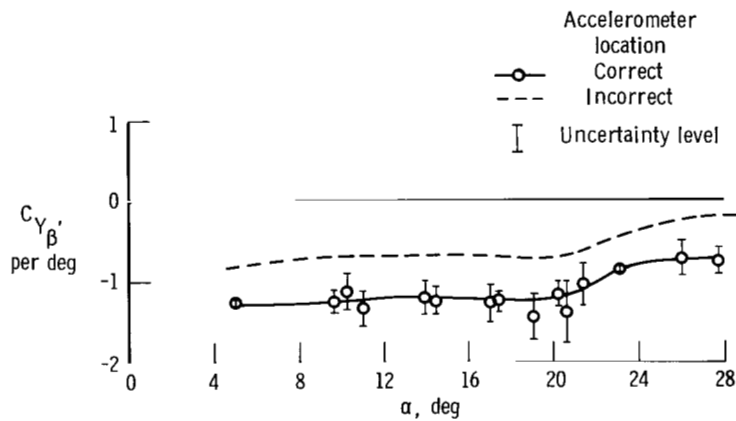

(b) *Correct accelerometer location.*

Figure 4. Values of $C_{Y\beta}'$ found when lateral accelerometer location is specified correctly and incorrectly.

shows the coefficient estimated when the assumed accelerometer position was changed by 15 centimeters, as in figure 3(b). The values of $C_{Y\beta}'$ in figure 4(b) are approximately 50-percent greater in magnitude than those in figure 4(a). Obviously, the stability and control derivative estimates are sensitive to instrument location.

Aircraft carry a wide range of instrumentation to sense angle of attack and angle of sideslip, including boom-mounted vanes, "cheek" or "chin" vanes, differential pressure ports, and inertial navigation systems. Care should be exercised in choosing the type of instrumentation for derivative estimation purposes. "Cheek" and "chin" vanes are subject to local flow effects and require extensive

calibration, pressure ports are noted for measurement lags, and inertial navigation systems do not account for wind shears or turbulence. Boom-mounted vanes have been found to be the most satisfactory method of measuring these parameters. However, local flow effects must still be evaluated and vane dynamics may be a problem. In addition, installation of a rigid boom may involve significant modification to the vehicle.

While instrumentation and data acquisition can pose certain problems for the analyst, these problems can usually be overcome by care and planning. The analyst need only know what the instruments actually measure and to what effects the estimator is sensitive.

APPLICATIONS AND SPECIAL PROBLEMS

For 12 years, the NASA Dryden Flight Research Center (DFRC) has used the maximum likelihood technique to estimate stability and control derivatives from flight data. During this time, a considerable amount of experience has been gained in both the theoretical and practical aspects of using this method. Stability and control derivatives have been obtained from over 3500 maneuvers from 32 aircraft, including many unusual configurations. Among these aircraft are a hypersonic rocket-powered research vehicle (the X-15); a series of lifting bodies (the M2-F2, HL-10, M2-F3, X-24A, and X-24B); two large commercial airliners (the CV-990 and B-747); several general aviation aircraft (including the Piper Comanche and the Beech 99); a high-altitude reconnaissance aircraft (the YF-12); two large supersonic bombers (the B-70 and B-1); several remotely piloted aircraft, including an oblique wing vehicle; and a large number of fighter aircraft (the F-8, F-111, F-15, YF-16, and YF-17). The flight conditions have included Mach numbers up to 5, altitudes up to 30 kilometers, angles of attack from -20° to 53° , and normal accelerations up to 4 g's. Virtually all derivative extraction at the Dryden Flight Research Center is now done with maximum likelihood estimators.

Most of the data acquired have been successfully analyzed using a simple linear model. For a linear model, equations (1) and (2) can be written in the following form:

$$\dot{\hat{x}}(t) = Ax(t) + Bu(t) \quad (5)$$

$$y(t) = Cx(t) + Du(t) \quad (6)$$

The simple linear two-degree-of-freedom model of the longitudinal dynamics of an aircraft is given by the following equations from reference 17.

$$\dot{\hat{x}}(t) = \begin{bmatrix} \dot{\alpha}(t) \\ \dot{q}(t) \\ \dot{\theta}(t) \end{bmatrix} = \begin{bmatrix} Z_\alpha & 1 & (-\sin \theta)(\cos \varphi)g/V \\ M_\alpha & M_q & 0 \\ 0 & \cos \varphi & 0 \end{bmatrix} \begin{bmatrix} \alpha(t) \\ q(t) \\ \theta(t) \end{bmatrix} + \begin{bmatrix} Z_{\delta_e} & Z_0 \\ M_{\delta_e} & M_0 \\ 0 & \dot{\theta}_0 \end{bmatrix} \begin{bmatrix} \delta_e(t) \\ 1 \end{bmatrix} \quad (7)$$

$$y(t) = \begin{bmatrix} \alpha(t) \\ q(t) \\ \theta(t) \\ a_n(t) \end{bmatrix} = \begin{bmatrix} 1 & 0 & 0 \\ 0 & 1 & 0 \\ 0 & 0 & 1 \\ (-V/g)Z_\alpha & 0 & 0 \end{bmatrix} \begin{bmatrix} \alpha(t) \\ q(t) \\ \theta(t) \end{bmatrix} + \begin{bmatrix} 0 & 0 \\ 0 & 0 \\ 0 & 0 \\ (-V/g)Z_{\delta_e} & a_{n_{bias}} \end{bmatrix} \begin{bmatrix} \delta_e(t) \\ 1 \end{bmatrix} \quad (8)$$

$$z(t) = y(t) + \eta(t) \quad (9)$$

$$\xi^* = \left(Z_\alpha \ M_\alpha \ M_q \ Z_{\delta_e} \ M_{\delta_e} \ Z_0 \ M_0 \ \dot{\theta}_0 \ a_{n_{bias}} \right)$$

$J(\xi)$ of equation (4) is then minimized over the time interval T by adjusting the five stability and control derivatives and the three bias terms in the vector ξ to minimize the difference between the measured response and the computed response, $z(t)$ and $\hat{z}_\xi(t)$.

The simple linear lateral-directional model is given by the equations

$$\dot{x}(t) = \begin{bmatrix} \dot{\beta}(t) \\ \dot{p}(t) \\ \dot{r}(t) \\ \dot{\phi}(t) \end{bmatrix} = \begin{bmatrix} Y_\beta & \sin \alpha & -\cos \alpha & (\cos \phi)(\cos \theta)g/V \\ L_\beta & L_p & L_r & 0 \\ N_\beta & N_p & N_r & 0 \\ 0 & 1 & (\cos \phi)(\tan \theta) & 0 \end{bmatrix} \begin{bmatrix} \beta \\ p \\ r \\ \phi \end{bmatrix} + \begin{bmatrix} Y_{\delta_a} & Y_{\delta_r} & Y_0 \\ L_{\delta_a} & L_{\delta_r} & L_0 \\ N_{\delta_a} & N_{\delta_r} & N_0 \\ 0 & 0 & \dot{\phi}_0 \end{bmatrix} \begin{bmatrix} \delta_a(t) \\ \delta_r(t) \\ 1 \end{bmatrix} \quad (10)$$

$$y(t) = \begin{bmatrix} \beta(t) \\ p(t) \\ r(t) \\ \phi(t) \\ a_y(t) \end{bmatrix} = \begin{bmatrix} 1 & 0 & 0 & 0 \\ 0 & 1 & 0 & 0 \\ 0 & 0 & 1 & 0 \\ 0 & 0 & 0 & 1 \\ (V/g)Y_\beta & 0 & 0 & 0 \end{bmatrix} \begin{bmatrix} \beta(t) \\ p(t) \\ r(t) \\ \phi(t) \end{bmatrix} + \begin{bmatrix} 0 & 0 & 0 \\ 0 & 0 & 0 \\ 0 & 0 & 0 \\ 0 & 0 & 0 \\ (V/g)Y_{\delta_a} & (V/g)Y_{\delta_r} & a_{y_{bias}} \end{bmatrix} \begin{bmatrix} \delta_a(t) \\ \delta_r(t) \\ 1 \end{bmatrix} \quad (11)$$

$$z(t) = y(t) + \eta(t) \quad (12)$$

$$\xi^* = \left[Y_\beta \ (\sin \alpha) \ L_\beta \ L_p \ L_r \ N_\beta \ N_p \ N_r \ Y_{\delta_a} \ Y_{\delta_r} \ Y_0 \ L_{\delta_a} \ L_{\delta_r} \ L_0 \ N_{\delta_a} \ N_{\delta_r} \ N_0 \ \dot{\phi}_0 \ a_{y_{bias}} \right]$$

The MMLE program (ref. 11) was designed to handle these simple longitudinal and lateral-directional models. While these models are representative of most aircraft at many flight conditions, occasionally unusual aircraft configurations,

unusual analysis requirements, or unusual flight conditions create special problems for the analyst. Several of these problems are discussed below. Some of these problems require the use of a more versatile program such as MMLE 3 (see appendix).

Turbulence

Most flight data are analyzed with algorithms that do not model the effect of turbulence. These algorithms perform poorly when significant turbulence is present. Figure 5 is a comparison of longitudinal flight data obtained in atmospheric

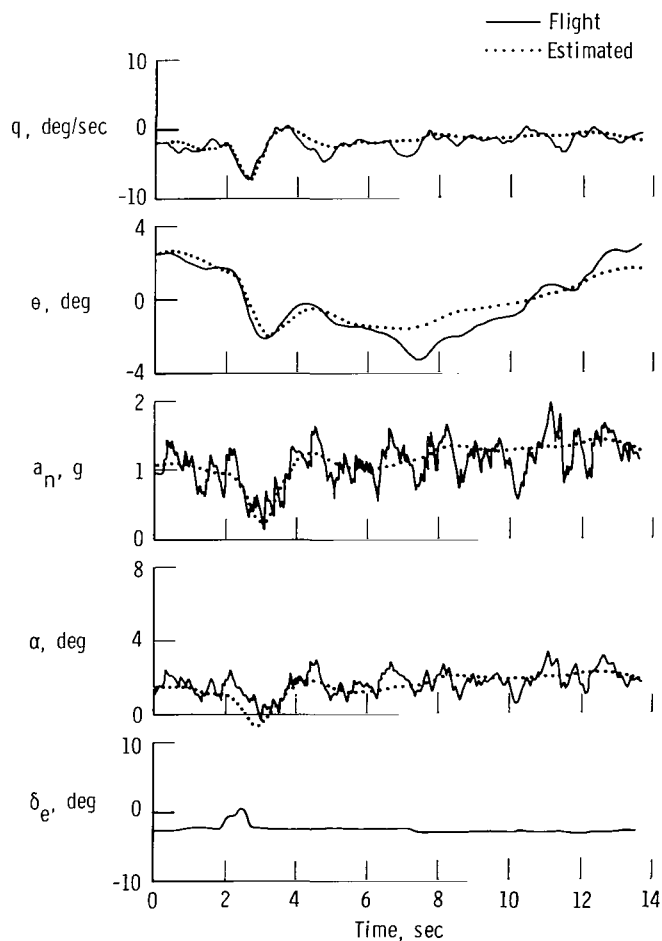

Figure 5. Comparison of flight data obtained in turbulence with computed data from estimator that does not account for turbulence.

turbulence with the computed data from a maximum likelihood estimator that does not account for turbulence. The estimator uses the linear model described by equations (7) to (9). The fit is obviously unacceptable, and poor derivative estimates resulted. The maximum likelihood estimator can use a model that includes turbulence effects (ref. 18), but this results in increased computational complexity. The method then estimates the turbulence time history, in addition to the unknown coefficients. The flight data of figure 5 were analyzed with a maximum likelihood estimator that accounts for turbulence, and the resulting fit is shown in figure 6. The fit is excellent, and reasonable derivative estimates were obtained (ref. 18).

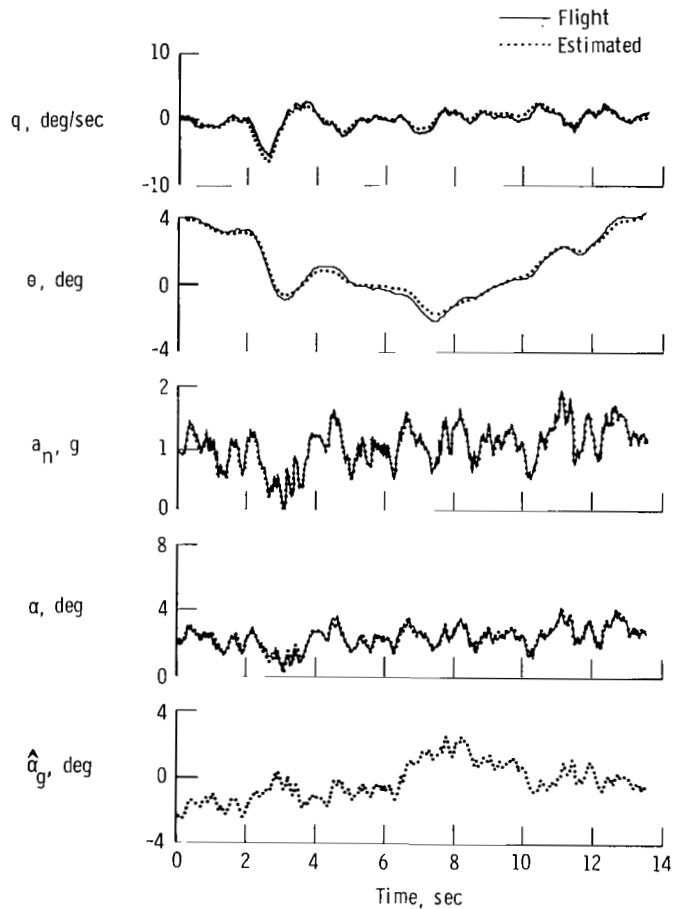

Figure 6. Comparison of flight data obtained in turbulence with computed data from estimator that accounts for turbulence.

Thus, the capability for obtaining derivative estimates in the presence of turbulence does exist. However, several cautions must be stated. First, the computation time required is generally about 30 percent greater than with the estimator that does not account for turbulence. Second, it is conceivable that

the aerodynamic derivatives are different in turbulence than in smooth air. Although such differences have not been documented in flight, care must be exercised in using derivatives obtained in turbulence for application in smooth air. Of course if handling qualities in turbulence are being studied, the converse problem exists. Third, questions arise about the accuracy of the turbulence model used and the sensitivity of the algorithm to errors in modeling the turbulence. Because of these three considerations, every attempt should be made to obtain most data in smooth air. However, for data that are difficult or expensive to repeat, or for experiments explicitly related to turbulence, the algorithm that accounts for turbulence is available.

Structural Modes

The identification of structural coefficients from flight data is of great importance for modern aircraft. Research is currently being conducted in this area by many aircraft organizations, and certain successes have already been reported (ref. 19). In addition, structural modes are of interest when performing a stability and control analysis. Several techniques are available for treating data corrupted by structural vibration to improve the results of the stability and control analysis. Three of these techniques—the removal of the structural effects, pseudostatic structural modeling, and dynamic structural modeling—are discussed in this section.

The most common approach to structural vibration problems is to remove the effects of the structural vibration. This approach assumes that the structural vibration is in relatively high-frequency modes, uncoupled from the rigid-body oscillation. The power spectra of the signals are obtained, and digital notch or low-pass filters are designed (ref. 20) to remove the structural effects without degrading the rigid-body data. Care must be exercised to avoid introducing data time skews by filtering. Such time skews could present more problems than the original structural vibration (ref. 15). The advisable approach is to filter all the signals with the same digital filter. The necessity for such digital filtering must be considered when the data system sampling rates are chosen: Sampling rates of 100 to 200 samples per second are often required for input to the filter, even though the filtered data are used at only 10 to 50 samples per second (ref. 21). Although the increased sampling rate requirement can be eliminated by using active analog filters before the data are sampled, this method creates other problems. The unfiltered data cannot be recovered and the filter characteristics cannot be changed after the flight. Also, the addition of analog filters requires hardware changes in the data system. Passive analog filters should be avoided if possible, because the filter break frequency, and thus the time lag, changes with the impedance loading. Unless the lags are very small, each passive filter in the system must be checked to determine its actual lag.

High-frequency structural vibration in the measurements is often caused by mounting the instrument package on a flexible member. Therefore, the effects of such vibrations on the data can often be alleviated by mounting the instrument package at a location less subject to vibration. Obviously, such a solution is not always practical.

The second approach to accounting for structural effects is pseudostatic structural modeling. This approach is appropriate for aircraft that deform under load, causing the vehicle shape to be significantly different for different flight conditions. For such aircraft, the aerodynamic coefficients are functions of dynamic pressure or load factor. This pseudostatic deformation effect requires no modification of the analysis technique. It does, however, require the investigation of a wide range of flight conditions to determine the trends of the coefficients as a function of flight condition.

The stability and control derivative estimates are often quite insensitive to pseudostatic structural deformations. Figure 7 shows flight-determined estimates

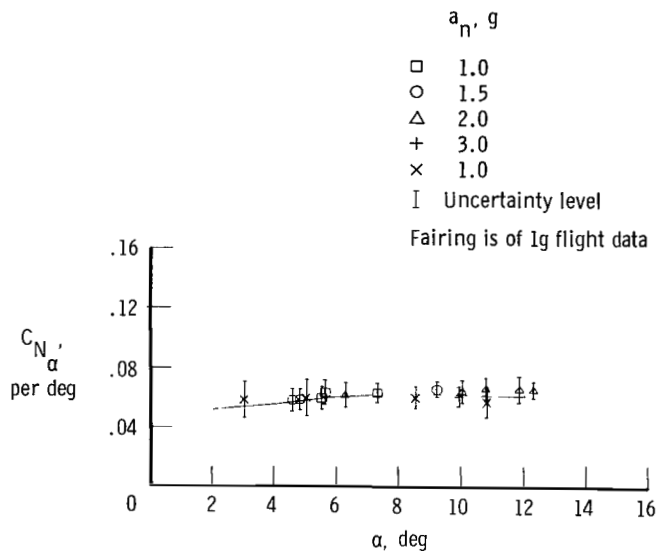

Figure 7. C_{N_α} for elevated g flight.

of C_{N_α} for an F-111A airplane with a wing sweep angle of 58° and load factors of 1 to 3 g's (ref. 22). Although the F-111A airplane is large and relatively flexible for a fighter airplane, no effects of the structural deformation are apparent in the data shown.

The third method of accounting for structural effects is to dynamically model the structural modes and their interactions with the aerodynamics. For large flexible aircraft, where the structural modes have low frequencies and couple significantly with the rigid-body motion, this may be the only applicable analysis technique. This is a currently active research area, and, although many investigations are addressing the structural identification problem, no completely satisfactory practical application has been demonstrated. Therefore, no definitive list is

available of the instrumentation, maneuvers, and ground test data required to obtain accurate coefficient estimates in the presence of dynamic aerostructural interaction.

Linear Dependence Problems

Many of the difficulties in estimating stability and control coefficients from flight data are linear dependence problems (ref. 3): Two or more of the variables to be estimated are linearly dependent and cannot be separately estimated from the data available. There are two basic causes of these problems.

The first cause of linear dependence problems is an overly complex model. There is a temptation for the analyst to make the model as detailed and accurate as possible, including every term that might conceivably arise in any situation. The increased computational costs are accepted in exchange for the presumably increased accuracy and greater generality. If the additional terms are completely known, as in the case of kinematic cross-coupling terms (see Cross Coupling section), there are no particular problems with this approach. However, the additional terms often include unknown coefficients, which must be estimated along with the basic stability and control derivatives. If too many coefficients are unknown, there will not be enough information in the data to obtain accurate estimates. Not only will the estimates of the added coefficients be poor, but the estimates of the basic stability and control derivatives will also be degraded. In other words, rather than increased accuracy, a complicated model can actually result in poorer estimates. In some cases, the algorithm will not converge and no estimates can be obtained. Because of these difficulties, a program should not be designed to handle all situations, then left in the hands of an inexperienced technician. Rather, the program should be designed for a basic set of equations, with options or modifications that apply to specific circumstances. The analyst must have the experience, or be guided by someone with the experience, to recognize the important factors in each situation and invoke the appropriate option or modifications.

The second cause of linear dependence problems is inadequate control input. If the control input does not adequately excite all the dynamic modes of the model, it may not be possible to estimate all the coefficients. Problems with inadequate control inputs are common when the airplane is flown with the stability augmentation system (SAS) on. Without additional information, it is impossible to distinguish between the basic airframe damping and the damping induced by the control feedback. To obtain derivatives from SAS-on maneuvers, each control surface must have an independent control input in addition to the SAS feedback.

A similar problem occurs when two or more control surfaces move nearly in phase. A common example occurs when deflection of the lateral stick moves both the differential tail and the wing ailerons. In this case, only an overall equivalent derivative that combines the differential tail and aileron effects can be estimated. To separate the individual control effects, each control surface must have an independent input.

The Cramer-Rao bounds (uncertainty levels) are useful for evaluating whether linear dependence problems exist (ref. 3). These bounds give an estimate of the uncertainty in each coefficient. Figure 8 shows estimates of C_{n_p} for a PA-30

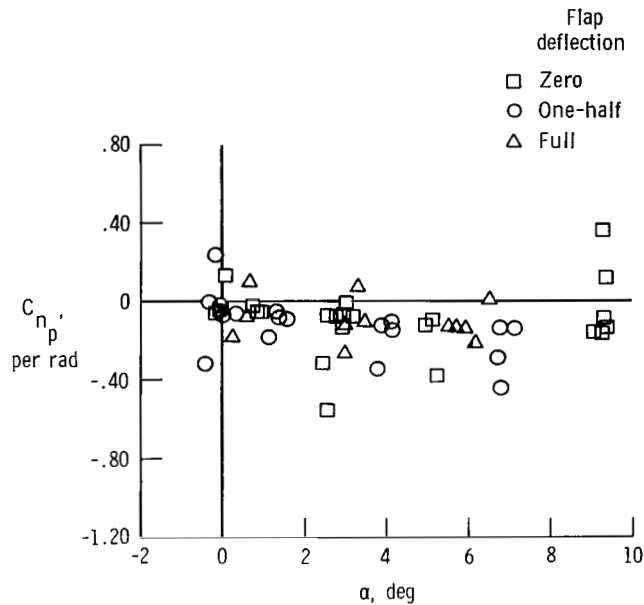

Figure 8. Variation of C_{n_p} with angle of attack without uncertainty levels.

airplane at three flap settings. There is a significant amount of scatter, and little information about C_{n_p} can be gleaned from this figure. In figure 9, the same data are shown with uncertainty levels. The data points with small Cramer-Rao bounds can be faired readily when the points with large Cramer-Rao bounds are ignored.

In an attempt to determine the reason for the poor Cramer-Rao bounds associated with some of the data in figures 8 and 9, the data from rudder and aileron maneuvers were plotted separately (fig. 10). The data from the aileron maneuvers form a well-defined line with little scatter and good Cramer-Rao bounds, but the rudder maneuvers result in a large amount of scatter and poor Cramer-Rao bounds. It is obvious that the rudder pulse does not excite the airplane motion adequately for identification purposes. To best identify all the stability and control derivatives of the PA-30 airplane, maneuvers with both aileron and rudder inputs should be used. As a substitute, an aileron maneuver can be analyzed together with a rudder maneuver to obtain a single set of estimates based on both sets of data. Figure 11 shows the same data as in figure 10, reanalyzed with the multiple maneuver approach (refs. 3 and 9). The scatter and poor Cramer-Rao bounds have disappeared. The fairing from the aileron maneuvers (fig. 10) is shown to be a good representation of the response to both aileron and rudder pulses.

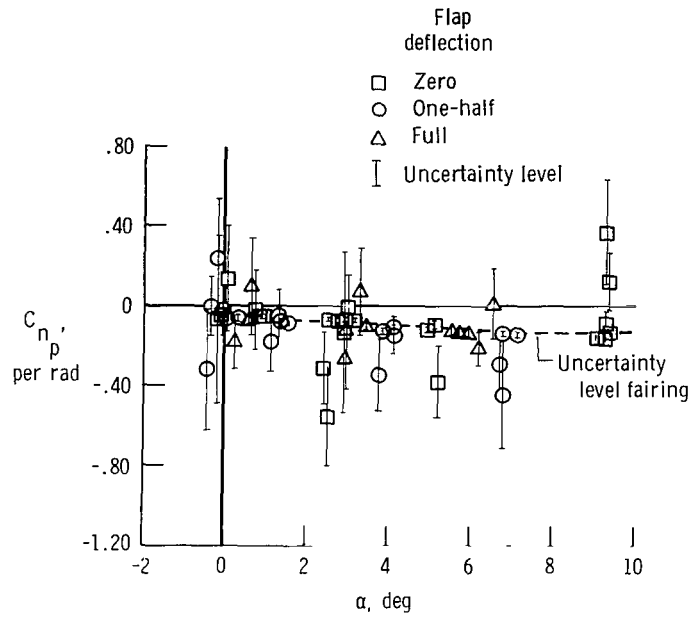

Figure 9. Variation of C_{n_p} with angle of attack with uncertainty levels.

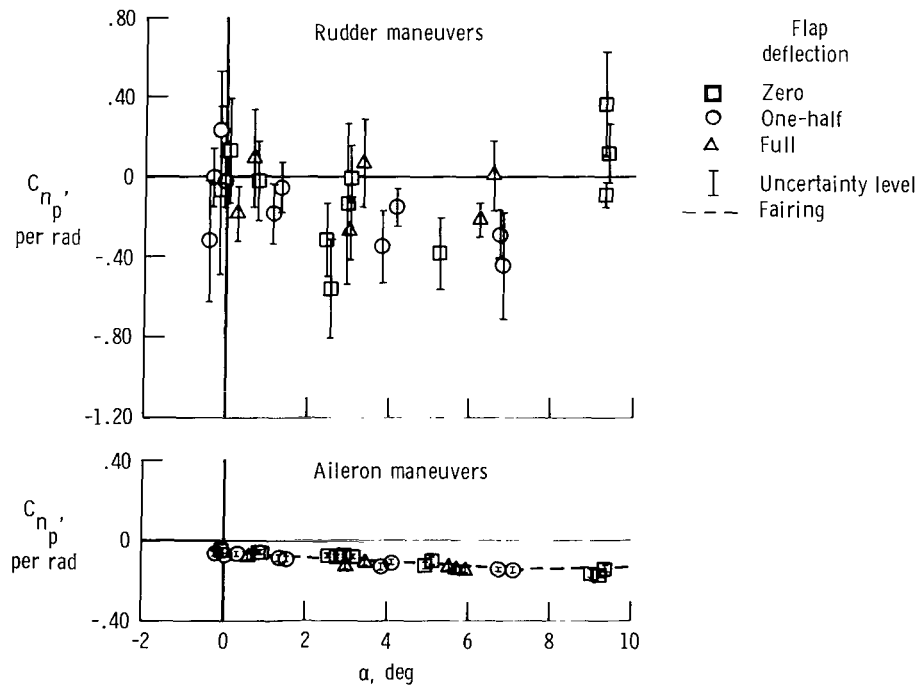

Figure 10. Variation of C_{n_p} with angle of attack for rudder and aileron maneuvers.

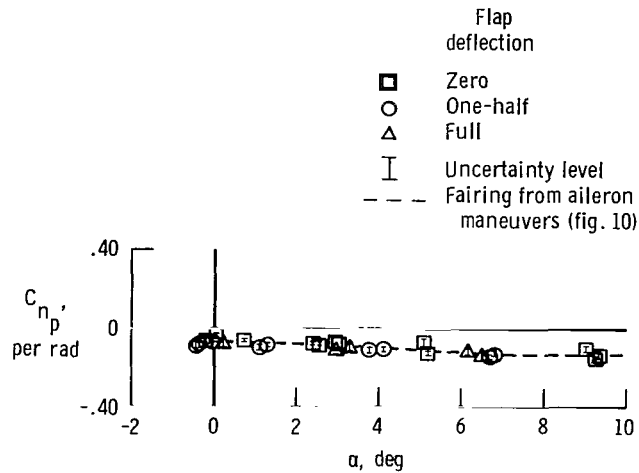

Figure 11. Variation of C_{n_p} with angle of attack for multiple maneuver analysis.

These PA-30 data provide a good example of a linear dependence problem and the use of the Cramer-Rao bound to help deduce the reasons for the problem and devise a solution. The particular problem illustrated here, the inadequacy of the rudder inputs, is symptomatic of many aircraft. In general, both rudder and aileron inputs should be included in each lateral-directional maneuver to insure adequate excitation.

Time-Varying Systems

One of the most common simplifications used by the data analyst is the assumption that the system being studied does not vary significantly during the brief time span of a maneuver. This simplification translates into especially simple models. In equations (7) to (12), this means that the dimensional derivatives, the biases, and the terms composed of V , θ , and ϕ are all assumed constant during the maneuver. However, under many circumstances the system varies significantly during the maneuver. In some of these cases, the analysis technique can be extended to cover the time variation of the system.

If dynamic pressure or velocity changes significantly during a maneuver, the dimensional derivatives will change correspondingly. Fortunately, the dependence of the dimensional derivatives on dynamic pressure and velocity is well known. The nondimensional derivatives do not usually vary significantly with velocity and dynamic pressure. The approach taken, therefore, is to identify the nondimensional derivatives. The dimensional derivatives in the equations of motion can then be written as the nondimensional derivatives multiplied by the dimensionalization ratios, which are computed as known functions of time using the measured velocity

and dynamic pressure. By writing the equations in this manner, the known time variation of the system can be accounted for.

The problem of determining time-varying coefficients is then replaced by the problem of determining constant coefficients with known time-varying multipliers. This technique relies on noise-free measurements of velocity, dynamic pressure, and other changing flight conditions. The technique cannot be applied to transonic data where significant changes in Mach number occur, because the dimensionless derivatives are functions of Mach number.

In both the case of large variations in altitude and the case of varying flight conditions, the time-varying nature of the system is reduced to known effects. Thus, the analyst is not determining time-varying derivatives in the general sense. The computer costs for the analysis of these "time-varying" systems are high. As implemented in the MMLE 3 program, the "time-varying" option triples the computer time used. Although expensive, the "time-varying" option permits the analysis of the most commonly encountered time-varying systems in aircraft stability and control derivative determination while retaining the basic simplicity of the model used.

Nonlinearities

Most airplanes show great nonlinearities in total forces and moments when considered over large ranges of flow angles. These nonlinearities are neglected in the typical derivative estimation process because the derivatives are local linearizations of the total forces and moments. For example, the pitching moment coefficient, C_m , as a function of α is quite nonlinear over a large angle-of-attack range. If the change in angle of attack can be kept small for a given maneuver, the locally linearized derivative, C_{m_α} , can be estimated and plotted as a function of angle of attack. Figure 12 (from ref. 23) shows C_{m_α} as a function of α for an angle-of-attack range of -20° to 50° . The estimates are consistent and show a clear trend that is in fair agreement with wind-tunnel estimates. By using the linear perturbation model for each maneuver, an excellent comparison can be made with the globally nonlinear wind-tunnel data. This simple and widely used technique avoids many of the problems of modeling nonlinear systems and is readily applied to aircraft where maneuvers are typically small perturbations about a point in a much larger envelope.

In some cases, the linear model of the aircraft is inadequate to determine the needed information, and the known system nonlinearity must be addressed directly by the maximum likelihood technique. An example of this type of problem is the need to estimate the drag polar of an aircraft. The simplified drag polar is

$$C_D = C_{D_0} + C_{D_I} C_L^2$$

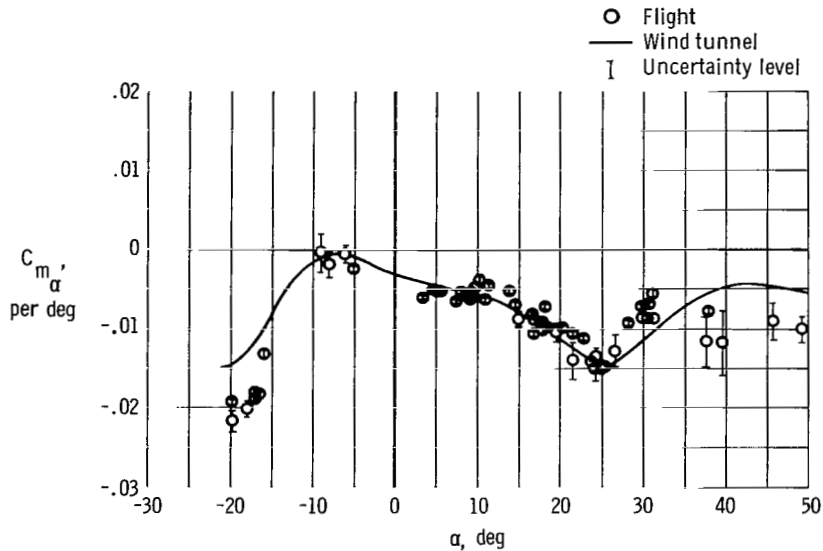

Figure 12. Comparison of flight and wind-tunnel estimates of C_{m_α} over a large angle-of-attack range.

where the second term, $C_{D_I} C_L^2$, accounts for the induced drag. This term results in an essential nonlinearity in the problem—that is, although C_L can be written as a linear function of the angle of attack and elevator position, C_D cannot. Therefore, the estimation of C_D from dynamic data involves equations that cannot be written in the linear form given by equations (5) and (6), and the more general functional form of equations (1) and (2) must be used. A complete description of this analysis is given in reference 24, and the results shown in figures 13 and 14 are from that reference. Figure 13 is a comparison of the measured and computed responses of an aircraft during a pushover-pullup maneuver where the computed response is generated by a nonlinear model incorporating a drag polar. The agreement is considered excellent. In figure 14, the drag polar obtained from this maneuver is compared with wind-tunnel estimates of the drag polar.

The fundamental problem of nonlinear maximum likelihood estimation is that, in practice, the form of the nonlinear model is unknown. In cases where the form of the model is known, as in the drag polar case, meaningful estimates can be expected if the maneuvers excite the nonlinearity of the system. Very little useful experience is available to guide the analysis of nonlinear systems where a linearized model is inadequate and the form of the nonlinearity is not known. If *ad hoc* techniques are used in modeling unknown nonlinearities, great care must be taken or meaningless results may be obtained.

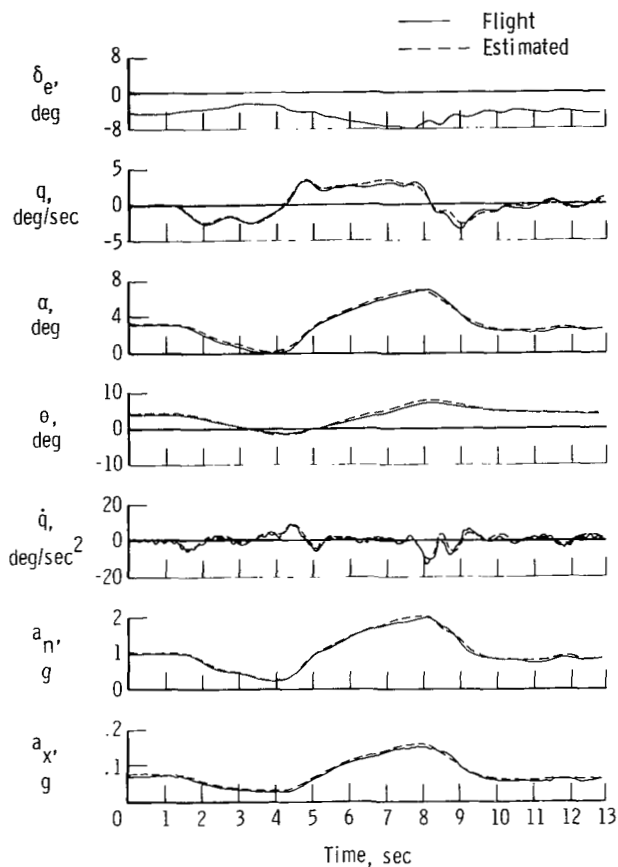

Figure 13. Comparison of flight data and data estimated by using a nonlinear model for a pushover-pullup maneuver.

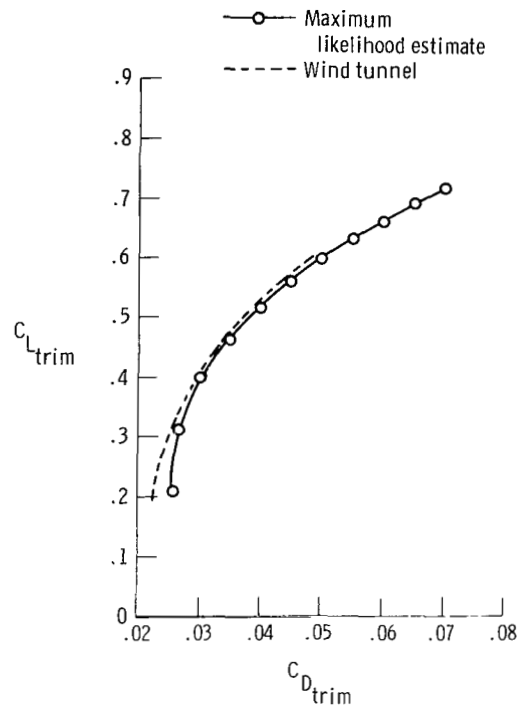

Figure 14. Comparison of drag polars obtained from estimates based on wind-tunnel and flight data.

Cross Coupling

The simplified aircraft equations of motion (eqs. (7) to (12)) are separated into longitudinal and lateral-directional modes, and it is assumed that no cross coupling exists. When significant coupling does exist, there are two approaches that can be used. The most obvious approach is to use the full nonlinear six-degree-of-freedom equations of motion with coupling terms. Although simple in principle, this method is plagued with practical difficulties. These include problems of complexity, maneuver design, and computer time and core. The second approach is to use the measured lateral-directional data as inputs to the longitudinal equations and the measured longitudinal data as inputs to the lateral-directional equations (ref. 21). This approach requires that the measurements of all the state variables be available and have low noise levels.

Two types of cross coupling exist. The first type is kinematic cross coupling, which is cross coupling arising from the equations of motion. A typical example is gyroscopic forces. Kinematic cross coupling can be a problem even with symmetrical aircraft. One of the most common kinematic cross coupling problems is nose slice during longitudinal pulses in steady turns. To account for nose slice, the kinematic cross coupling term $r(\sin \phi)$ must be added to the $\dot{\theta}$ equation.

The second type of cross coupling is aerodynamic cross coupling, which appears in the expansions of the force and moment coefficients. Predictions indicate that aerodynamic cross coupling is significant at high angles of attack, even for symmetric aircraft (ref. 25). For asymmetric aircraft, of course, aerodynamic cross coupling exists at all angles of attack.

Figure 15 is a three-view drawing of an oblique wing RPRV flown at the Dryden Flight Research Center (ref. 21). The wing of this aircraft can be skewed up to

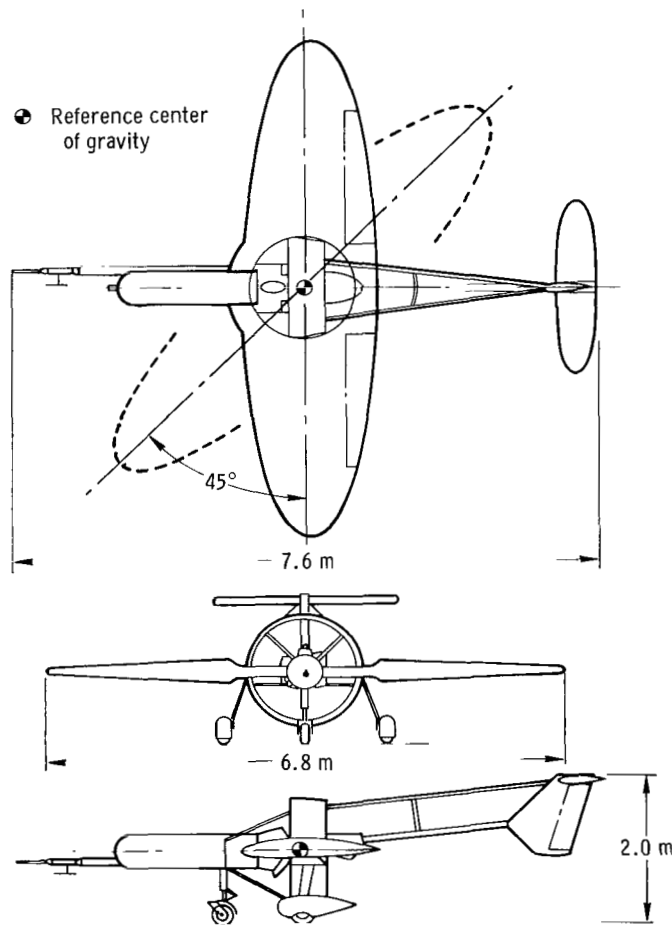

Figure 15. Three-view drawing of remotely piloted oblique wing aircraft.

45°. The oblique wing concept is of interest because of its potential for transonic drag reduction. When the wing is skewed, both aerodynamic and kinematic cross coupling are important. Figure 16 shows a comparison of flight and estimated

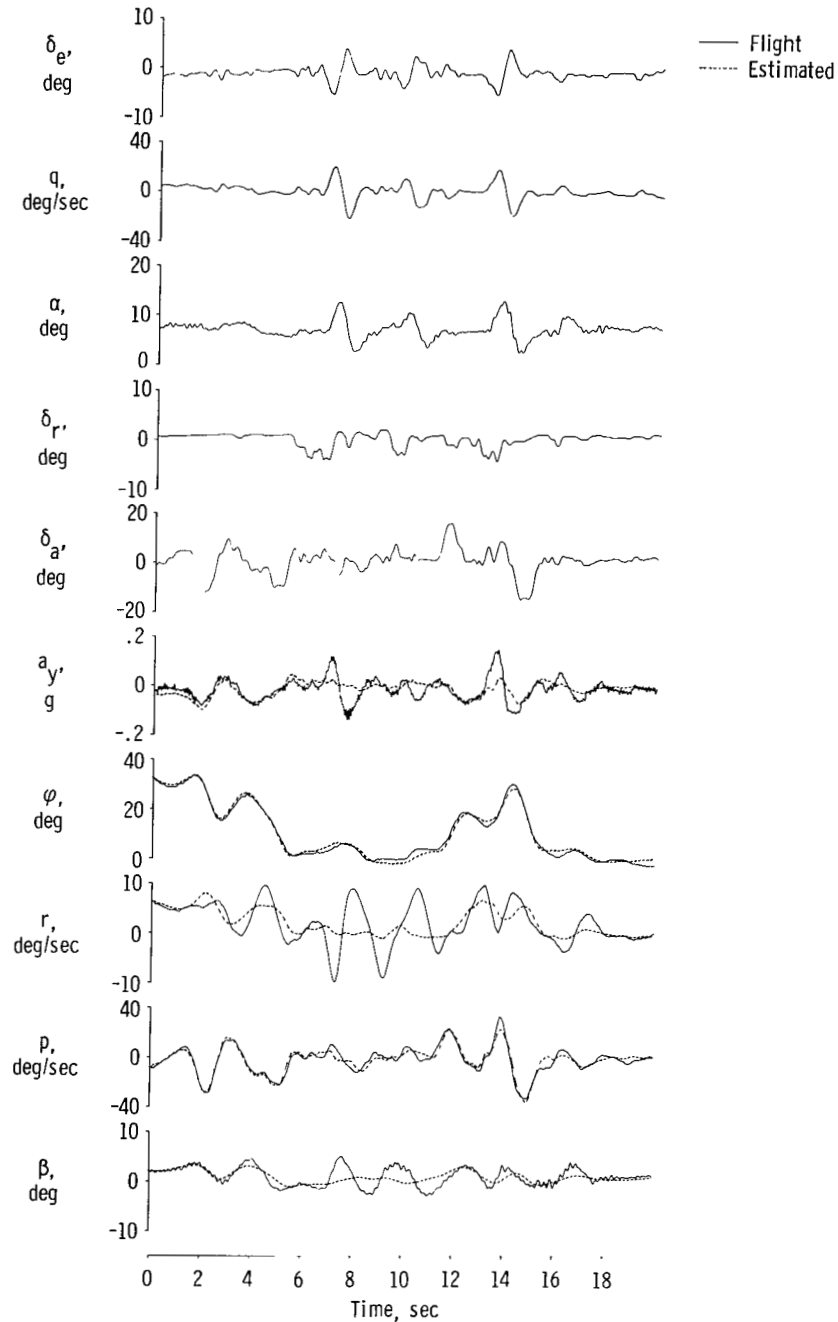

Figure 16. Comparison of flight-measured and estimated lateral-directional motions of oblique wing aircraft with 45° of wing skew where cross-coupling terms are omitted.

lateral-directional data obtained with the wing skewed to 45° . This unintentional maneuver was caused by interference in the radio control system. All the cross-coupling terms were ignored for this fit, which is totally unacceptable. Figure 17

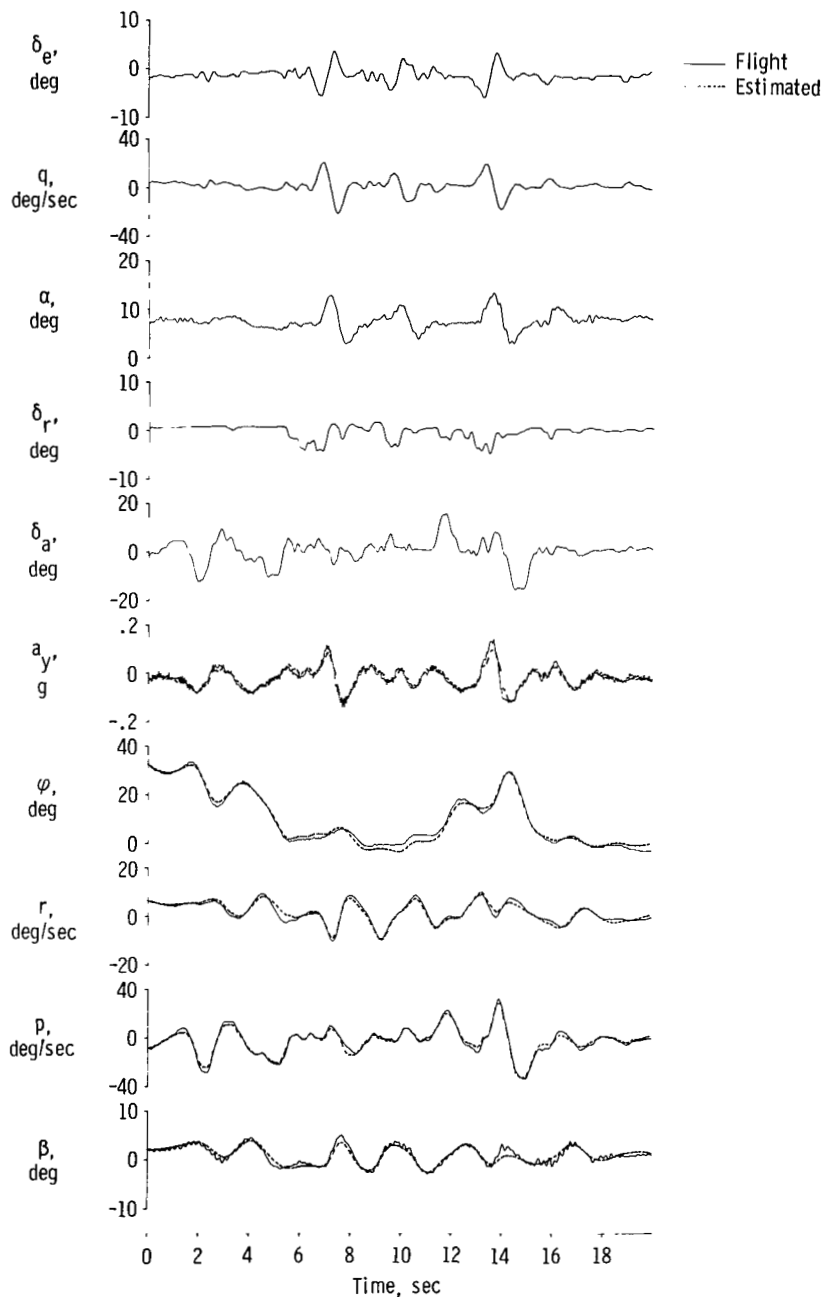

Figure 17. Comparison of flight-measured and estimated lateral-directional motions of oblique wing aircraft with 45° of wing skew where cross-coupling terms are included.

shows the data for the same maneuver when both kinematic and aerodynamic cross-coupling terms are computed with measured longitudinal signals. The fit is now very good considering the unconventional nature of the maneuver. This example shows that cross-coupling effects can be accurately accounted for using this simple technique.

Estimation of Pitching Moment Due to Vertical Acceleration

The estimation of $C_{m\dot{\alpha}}$ from flight data is a problem that exemplifies many of the considerations discussed previously. The derivative $C_{m\dot{\alpha}}$ cannot normally be estimated from flight data because $C_{m\dot{\alpha}}$ and C_{m_q} are linearly dependent. Analysts have had to be content with estimating $C_{m\dot{\alpha}} + C_{m_q}$. At DFRC, maneuvers specifically designed to remove the dependence of C_{m_q} and $C_{m\dot{\alpha}}$ (ref. 26) have recently been developed. Figure 18 shows a comparison of flight and estimated data for one of these maneuvers, an aileron roll with a series of elevator pulses. The fit is excellent, and reasonable estimates of C_{m_q} and $C_{m\dot{\alpha}}$, as well as all the other longitudinal stability and control derivatives, were obtained. In figure 19, the estimates of C_{m_q} and $C_{m\dot{\alpha}}$ from 13 maneuvers are compared with simplified analytical predictions. Because the airplane undergoes a complete 360° roll in each of these maneuvers, the cross-coupling effects of the lateral-directional motion on the longitudinal analysis are extremely important. In fact, the removal of the linear dependence of C_{m_q} and $C_{m\dot{\alpha}}$ is primarily due to the cross-coupling effects. For the maneuver shown in figure 18, dynamic pressure varies from 3.5 to 7.5 kN/m², so a time-varying analysis is necessary. (The maximum permissible variation in dynamic pressure is about 10 percent for computer programs that do not account for time-varying effects.) The altitude changes are sufficiently large and rapid that pressure lags in the static pressure measurements are significant. The 0.4-second lag of the static pressure system results in errors of up to 10 percent in the uncorrected dynamic pressure. The successful analysis of this maneuver is a good indication of the state of the art in the estimation of stability and control derivatives from dynamic flight-test data.

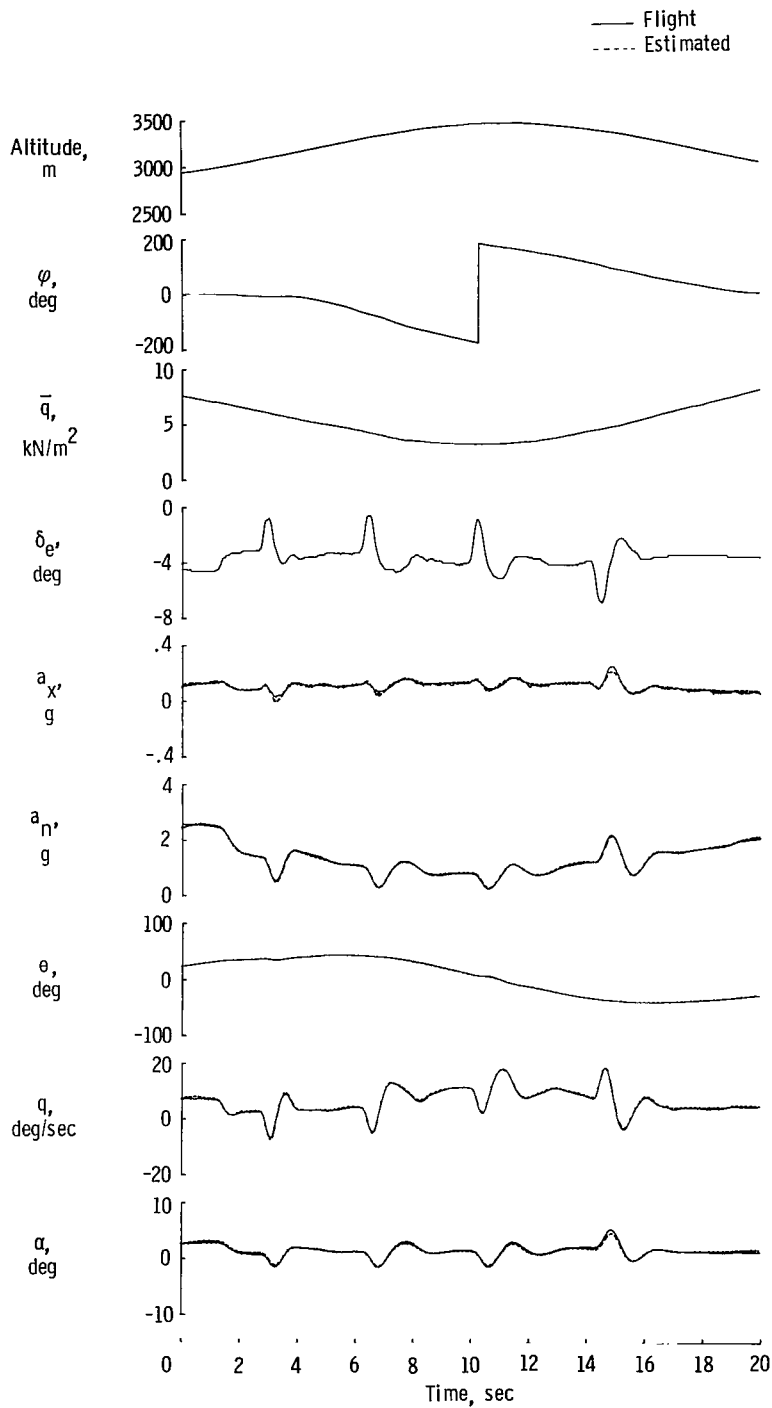

Figure 18. Comparison of flight-measured and estimated data for aileron roll with elevator pulses. C_{m_q} and $C_{m_{\dot{\alpha}}}$ estimated independently.

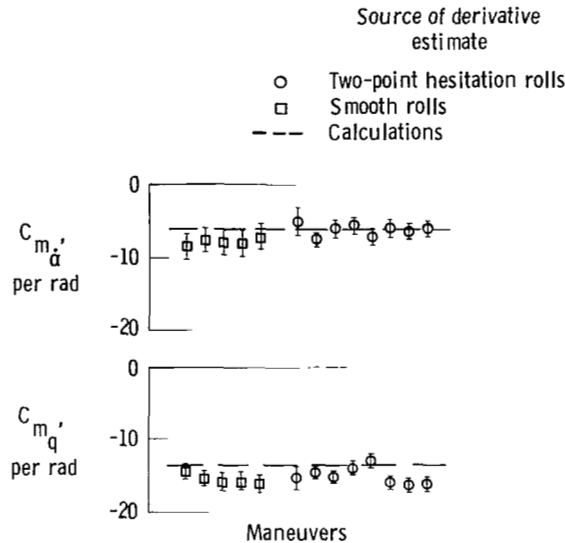

Figure 19. Comparison of independent flight estimates of $C_{m\dot{\alpha}}$ and $C_{m\dot{q}}$ with calculated values.

CONCLUDING REMARKS

During the past 12 years at the NASA Dryden Flight Research Center, the maximum likelihood estimator has been used to analyze over 3500 maneuvers from 32 aircraft. Most of the analysis has involved the extraction of stability and control derivatives from dynamic flight maneuvers. In this report, procedures for obtaining high-quality estimates from dynamic maneuvers were discussed, and the signals required for analysis were listed. The importance of well documented and accurate instrumentation was stressed, and several common instrumentation problems were presented.

The application of the maximum likelihood estimator to some special problems the analyst encounters when working with unusual aircraft configurations, analysis requirements, or flight conditions was also discussed. The analysis of data gathered in atmospheric turbulence was outlined, and three methods for handling the effects of flexibility on the estimation process were given. Sources of linear dependence problems were noted and potential solutions to these problems were considered. A class of problems with time-varying dimensional coefficients was shown to be solvable by proper formulation of the equations of motion. In addition, the maximum likelihood method was shown to be applicable to some nonlinear aircraft problems, with the determination of an aircraft drag polar given as an example. Kinematic and aerodynamic cross coupling between longitudinal and lateral-directional modes was discussed and illustrated using an example of the successful estimation of the

derivatives of an oblique wing aircraft. The use of a specially designed maneuver for separating the derivatives for rate of change of angle of attack ($\dot{\alpha}$) and pitch rate (q) was discussed. The analysis of this maneuver required several of the special techniques discussed previously and is an excellent example of the state of the art in estimating aircraft stability and control derivatives.

*Dryden Flight Research Center
National Aeronautics and Space Administration
Edwards, Calif. , November 28, 1978*

APPENDIX

DESCRIPTION OF MMLE 3 PROGRAM

The MMLE 3 program is an outgrowth of MMLE (ref. 11) that is currently in use at the Dryden Flight Research Center. The new program, which was developed to satisfy the need for more versatility, is designed to handle a general set of linear or bilinear dynamic equations of arbitrary order. Measurement noise and, optionally, process noise (such as turbulence) are included in the equations.

Because of its generality, MMLE 3 sometimes requires a large amount of input to completely specify a given problem. In addition, some program features that are useful for some problems have little or no meaning for other problems. To satisfy the conflicting requirements of generality and ease of use, the MMLE 3 program is divided into two levels. The basic level consists of a general maximum likelihood estimation program, applicable to any linear system. This program can be run by itself, using input data to completely describe the system to be analyzed and the program options to be used.

At the second level, the basic program is used as the core of a program adapted to a particular situation. The adaptation is accomplished by a set of user routines, so called because the user can write or modify them for his own application. When the user routines for a particular application are implemented, the program input need not contain the detailed system specifications, but only those items that change from case to case. The concept of a modular set of user routines allows the basic program structure to be very general, while retaining the simplicity of input possible in programs designed for specific systems. The use of user routines to simplify the required input deck is most advantageous when many cases are being processed. In addition, the user routines can be coded to perform computations or operations unique to a specific application. Examples of this function include reading data from special formats, normalizing or correcting the estimates to a given set of conditions, and punching the results in a form suitable to auxiliary programs for purposes such as plotting estimates or updating a simulator.

The MMLE 3 program includes a set of user routines tailored for the estimation of aircraft stability and control derivatives. With these routines, the MMLE 3 program is capable of analyzing a wide variety of aircraft stability and control maneuvers. Among the specific capabilities is the inclusion of kinematic and aerodynamic cross-coupling terms. Large variations in velocity and dynamic pressure during a maneuver can be handled by the program, as long as the nondimensional derivatives remain constant.

These standard user routines are based on the equations of motion presented in the following paragraphs. Various extensions to these equations are used in specific instances. The nonlinear terms in these equations are implemented by linearization about the measured values.

The basic longitudinal state equations are

$$\dot{\alpha} = -\frac{\bar{q}s}{mV} (C_L + \dot{\alpha}_0) + q + \frac{g}{V} (\cos \theta \cos \varphi \cos \alpha + \sin \theta \sin \alpha)$$

$$- \tan \beta (p \cos \alpha + r \sin \alpha)$$

$$I_Y \dot{q} = \bar{q} s c C_m + r p (I_Z - I_X) + (r^2 - p^2) I_{XZ}$$

$$\dot{\theta} = q \cos \varphi - r \sin \varphi + \dot{\theta}_0$$

and the longitudinal observation equations are

$$\alpha_m = K_\alpha \left(\alpha - \frac{x_\alpha}{V} q \right)$$

$$q_m = q$$

$$\theta_m = \theta$$

$$a_{n_m} = \frac{\bar{q}s}{mg} C_N + \frac{x_{a_n}}{g} \dot{q}$$

$$a_{x_m} = -\frac{\bar{q}s}{mg} C_A - \frac{z_{a_x}}{g} \dot{q}$$

$$\dot{q}_m = \dot{q} + \dot{q}_0$$

The expansions of the longitudinal force and moment coefficients are

$$C_N = C_{N_\alpha} \alpha + C_{N_\delta} \delta + C_{N_0}$$

$$C_m = C_{m_\alpha} \alpha + C_{m_q} \frac{qc}{2V} + C_{m_\delta} \delta + C_{m_0}$$

$$C_A = C_{A_\alpha} \alpha + C_{A_\delta} \delta + C_{A_0}$$

$$C_L = C_N \cos \alpha + C_A \sin \alpha$$

where the δ terms are summed over all controls.

The basic lateral-directional state equations are

$$\dot{\beta} = \frac{\bar{q}s}{mV}(C_Y + \dot{\beta}_0) + \frac{g}{V} \cos \theta \sin \varphi + p \sin \alpha - r \cos \alpha$$

$$\dot{p}I_X - \dot{r}I_{XZ} = \bar{q}s b C_{\ell} + qr(I_Y - I_Z) + pqI_{XZ}$$

$$\dot{r}I_Z - \dot{p}I_{XZ} = \bar{q}s b C_n + pq(I_X - I_Y) - qrI_{XZ}$$

$$\dot{\varphi} = p + r \cos \varphi \tan \theta + q \sin \varphi \tan \theta + \dot{\varphi}_0$$

and the lateral-directional observations are

$$\beta_m = K_{\beta} \left(\beta - \frac{z_{\beta}}{V} p + \frac{x_{\beta}}{V} r \right)$$

$$p_m = p$$

$$r_m = r$$

$$\varphi_m = \varphi$$

$$a_{y_m} = \frac{\bar{q}s}{mg} C_Y - \frac{z_a y}{g} \dot{p} + \frac{x_a y}{g} \dot{r}$$

$$\dot{p}_m = \dot{p} + \dot{p}_0$$

$$\dot{r}_m = \dot{r} + \dot{r}_0$$

The expansions of the lateral-directional force and moment coefficients are

$$C_Y = C_{Y_{\beta}} \beta + C_{Y_{\delta}} \delta + C_{Y_0}$$

$$C_{\ell} = C_{\ell_{\beta}} \beta + C_{\ell_p} \frac{pb}{2V} + C_{\ell_r} \frac{rb}{2V} + C_{\ell_{\delta}} \delta + C_{\ell_0}$$

$$C_n = C_{n_\beta} \beta + C_{n_p} \frac{pb}{2V} + C_{n_r} \frac{rb}{2V} + C_{n_\delta} \delta + C_{n_0}$$

where the δ terms are summed over all controls.

REFERENCES

1. Klein, V.: Determination of Longitudinal Aerodynamic Derivatives From Steady-State Measurement of an Aircraft. AIAA Paper 77-1123, Aug. 1977.
2. Iliff, Kenneth W.; and Taylor, Lawrence W., Jr.: Determination of Stability Derivatives From Flight Data Using a Newton-Raphson Minimization Technique. NASA TN D-6579, 1972.
3. Iliff, Kenneth W.; and Maine, Richard E.: Practical Aspects of Using a Maximum Likelihood Estimation Method To Extract Stability and Control Derivatives From Flight Data. NASA TN D-8209, 1976.
4. Hamel, P. G.: Status of Methods for Aircraft State and Parameter Identification. AGARD CP-187, 1976, pp. 8-1 to 8-16.
5. Eykhoff, Pieter: System Identification. John Wiley & Sons, Inc., c.1974.
6. Goodwin, Graham C.; and Payne, Robert L.: Dynamic System Identification: Experiment Design and Data Analysis. Academic Press, 1977.
7. Balakrishnan, A. V.: Stochastic Differential Systems I. Filtering and Control—A Function Space Approach. Lecture Notes in Economics and Mathematical Systems, 84, M. Beckmann, G. Goos, and H. P. Künzi, eds., Springer-Verlag (Berlin), 1973.
8. Powell, J. David; and Tyler, James S., Jr.: Application of the Kalman Filter and Smoothing to VTOL Parameter and State Estimation. 1970 Joint Automatic Control Conference of the American Automatic Control Council, Paper 18-G, American Soc. Mech. Eng., June 1970, pp. 449-450.
9. Iliff, Kenneth W.; and Maine, Richard E.: Further Observations on Maximum Likelihood Estimates of Stability and Control Characteristics Obtained From Flight Data. AIAA Paper 77-1133, Aug. 1977.
10. Herrington, Russell M.; Shoemaker, Paul E.; Bartlett, Eugene P.; and Dunlap, Everett W.: Flight Test Engineering Handbook. AF Tech. Rept. No. 6273, Air Force Flight Test Center, May 1951 (rev. June 1964).
11. Maine, Richard E.; and Iliff, Kenneth W.: A FORTRAN Program for Determining Aircraft Stability and Control Derivatives From Flight Data. NASA TN D-7831, 1975.
12. Wolowicz, Chester H.; and Yancey, Roxanah B.: Experimental Determination of Airplane Mass and Inertial Characteristics. NASA TR R-433, 1974.

13. Suit, William T.: Aerodynamic Parameters of the Navion Airplane Extracted From Flight Data. NASA TN D-6643, 1972.
14. Brenner, Martin J.; Iliff, Kenneth W.; and Whitman, Robert K.: Effect of Sampling Rate and Record Length on the Determination of Stability and Control Derivatives. NASA TM-72858, 1978.
15. Steers, Sandra Thornberry; and Iliff, Kenneth W.: Effects of Time-Shifted Data on Flight-Determined Stability and Control Derivatives. NASA TN D-7830, 1975.
16. Holleman, Euclid C.: Summary of Flight Tests To Determine the Spin and Controllability Characteristics of a Remotely Piloted, Large-Scale (3/8) Fighter Airplane Model. NASA TN D-8052, 1976.
17. Wingrove, R. C.: Estimation of Longitudinal Aircraft Characteristics Using Parameter Identification Techniques. Ninth Annual Symposium Proceedings—Why Flight Test? Soc. Flight Test Eng., Oct. 1978, pp. 9-1 to 9-24.
18. Iliff, Kenneth W.: Estimation of Characteristics and Stochastic Control of an Aircraft Flying in Atmospheric Turbulence. Proceedings of AIAA 3rd Atmospheric Flight Mechanics Conference, c.1976, pp. 26-38.
19. Rynaski, Edmund G.; Andrisani, Dominick, II; and Weingarten, Norman C.: Identification of the Stability Parameters of an Aeroelastic Airplane. AIAA Paper 78-1328, Aug. 1978.
20. Edwards, John W.; and Deets, Dwain A.: Development of a Remote Digital Augmentation System and Application to a Remotely Piloted Research Vehicle. NASA TN D-7941, 1975.
21. Maine, Richard E.: Aerodynamic Derivatives for an Oblique Wing Aircraft Estimated From Flight Data by Using a Maximum Likelihood Technique. NASA TP-1336, 1978.
22. Iliff, Kenneth W.; Maine, Richard E.; and Steers, Sandra Thornberry: Flight-Determined Stability and Control Coefficients of the F-111A Airplane. NASA TM-72851, 1978.
23. Iliff, Kenneth W.; Maine, Richard E.; and Shafer, Mary F.: Subsonic Stability and Control Derivatives for an Unpowered, Remotely Piloted 3/8-Scale F-15 Airplane Model Obtained From Flight Test. NASA TN D-8136, 1976.
24. Iliff, Kenneth W.: Maximum Likelihood Estimates of Lift and Drag Characteristics Obtained From Dynamic Aircraft Maneuvers. Proceedings of AIAA 3rd Atmospheric Flight Mechanics Conference, c.1976, pp. 137-150.

25. Orlik-Rückemann, K. J.: Aerodynamic Coupling between Lateral and Longitudinal Degrees of Freedom. AIAA J., vol. 15, no. 12, Dec. 1977, pp. 1792-1799.
26. Maine, Richard E.; and Iliff, Kenneth W.: Maximum Likelihood Estimation of Translational Acceleration Derivatives From Flight Data. AIAA Paper 78-1342, Aug. 1978.

1. Report No. NASA TP-1459	2. Government Accession No.	3. Recipient's Catalog No.
4. Title and Subtitle IMPORTANT FACTORS IN THE MAXIMUM LIKELIHOOD ANALYSIS OF FLIGHT TEST MANEUVERS		5. Report Date April 1979
7. Author(s) Kenneth W. Iliff, Richard E. Maine, and T. D. Montgomery		6. Performing Organization Code H-1076
9. Performing Organization Name and Address NASA Dryden Flight Research Center P. O. Box 273 Edwards, California 93523		8. Performing Organization Report No.
12. Sponsoring Agency Name and Address National Aeronautics and Space Administration Washington, D.C. 20546		10. Work Unit No. 505-06-64
Supplementary Notes		11. Contract or Grant No.
act		13. Type of Report and Period Covered Technical Paper
		14. Sponsoring Agency Code

This paper discusses the application of a maximum likelihood estimator to dynamic flight test data. The information presented is based on the experience in the past 12 years at the NASA Dryden Flight Research Center of estimating stability and control derivatives from over 3500 maneuvers from 32 aircraft. The overall approach to the analysis of dynamic flight test data is outlined. General requirements for data and instrumentation are discussed and several examples of the types of problems that may be encountered are presented.

17. Key Words (Suggested by Author(s)) Stability and control derivatives Dynamic flight data analysis Maximum likelihood estimation		18. Distribution Statement Unclassified-Unlimited	
		STAR category: 08	
19. Security Classif. (of this report) Unclassified	20. Security Classif. (of this page) Unclassified	21. No. of Pages 45	22. Price* \$3.75

**For sale by the National Technical Information Service, Springfield, Virginia 22161*

National Aeronautics and
Space Administration

THIRD-CLASS BULK RATE

Postage and Fees Paid
National Aeronautics and
Space Administration
NASA-451



Washington, D.C.
20546

Official Business

Penalty for Private Use, \$300

6 1 1U,A, 042079 S00903DS
DEPT OF THE AIR FORCE
AF WEAPONS LABORATORY
ATTN: TECHNICAL LIBRARY (SUL)
KIRTLAND AFB NM 87117

N

PER: If Undeliverable (Section 158
Postal Manual) Do Not Return

S