

VULNERABILITY

Israel Taback
The Bionetics Corporation

The discussion of vulnerability will begin with a description of some of the electrical characteristics of fibers before defining how vulnerability calculations are done. The vulnerability results secured to date will be presented. The discussion will touch on post exposure vulnerability which many have not heard about and then hazard some guesses about what future technology will do to the measurements made to date. After a description of some shock hazard work now underway, the discussion will lead into a description of the planned effort and present some preliminary conclusions.

On the upper left hand corner of figure 1 I have diagrammed a fiber and an external circuit. Electrically, fibers appear as a resistance per unit length plus two contacts which have some non-linear characteristics. The fibers that we have been working with show resistances of about 1000 to about 3000 ohms per centimeter of length depending upon the extent of graphitization.

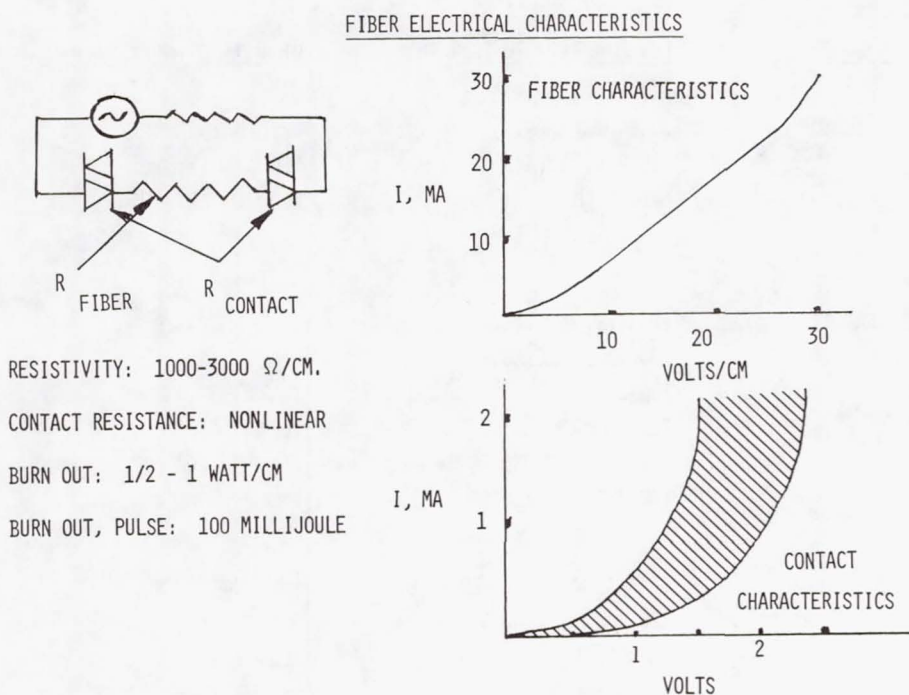

Figure 1

Their contact resistance is nonlinear. They burn out at about 1/2 to 1 watt per centimeter of length, and a one centimeter fiber will burn out with a pulse input of about 100 millijoules. If one plots the current through the fiber against the voltage across the fiber, there is a small nonlinear region at low voltage, a linear region which increases with increase in voltage, and then just before the fiber burns out and probably due to its negative temperature coefficient of resistance, a little further nonlinearity in the current voltage characteristics. Some of the fibers burn out at about 30 milliamperes; others will burn out at currents between 10 and 20 milliamperes. The contact characteristics of the fiber are somewhat similar to back-to-back diodes. The current that will pass through the fiber contact stays very low until a characteristic voltage is applied. For the fibers we have been working with it has the order of about 1½ to 2 volts. At this point the voltage drop at the contact remains fairly constant and relatively independent of current. Because of these characteristics the fibers have the potential for doing various types of damage.

Figure 2 is a fairly gross categorization chart. I have tried to generalize the types of damage that might occur with fibers based upon the voltage range that they may be used at and whether or not they are in a low power or high power circuit. One of the areas of concern is the low voltage and low power region. A fiber

<u>TYPICAL FIBER EFFECTS</u>		
<u>VOLTAGE RANGE</u>	<u>LOW POWER (UP TO 100W)</u>	<u>HIGH POWER (ABOVE 100W)</u>
LOW (0 TO 30 VOLTS)	SUSTAINED SHORTS FIBER NOT BURNED MALFUNCTIONS NO LOCAL DAMAGE	SUSTAINED SHORTS FIBER NOT BURNED NO EQUIPMENT DAMAGE
MEDIUM (30 TO 1000 VOLTS)	SPARKING OR SHORTS POSSIBLE FIBER BURN TRANSIENTS BLOWN FUSES STRESSED COMPONENTS LOW DAMAGE POTENTIAL	SOME SUSTAINED ARCS FIBER BURNS TRANSIENTS BLOWN FUSES STRESSED COMPONENTS DAMAGE USUALLY REPAIRABLE
HIGH (>1000 VOLTS)	SPARKS, NO SUSTAINED ARCS LOW VOLTAGE CORONA TRANSIENTS INTERRUPTIONS	SUSTAINED ARCS CORONA FLASHOVER MAY BE SEVERE DAMAGE

Figure 2

has the capability to maintain a high resistance short without burning out. The equipment can malfunction and although no local damage to components usually occurs the functioning of the device may be impaired. At low voltage and high power (for example a 12 volt battery circuit) shorts may also be sustained. The fiber may or may not burn out depending on the voltage; however, equipment is not usually damaged. This is not a problem area from the viewpoint that if a fiber does fall across a high power low voltage circuit, it may draw a little bit of power from the circuit but it probably would not stop the operation. The other area of concern is high power and relatively high voltage where the fiber essentially acts as a trigger to some potential arcing and that arcing may be sustained. This will stress components, blow fuses and cause flashover at insulators. There is another region where fiber can damage some types of equipment and that is in the high voltage high power area. Here one can encounter corona and initiate sustained arcs which can disrupt equipment and damage equipment.

As I say this is a very gross chart. The 0 to 30 volts may well be 0 to 10 or 15 and the 100 watts may well be anything from about half that to twice that; but the general characteristics of the types of problems listed are typical.

Figure 3 lists methods which are employed for evaluating

EQUIPMENT EVALUATION METHODS

DIRECT EXPOSURE IN TEST CHAMBER

FIBER SIMULATOR PROBE

GENERIC SIMILARITY

ANALYSIS & MODELING

Figure 3

equipment vulnerability. The most direct one, and the one I think has been used in most cases, is direct exposure of the equipment in a chamber. There are chambers at Langley Research Center, at Rome Air Development Center, and at Ballistic Research Labs in Aberdeen, Maryland. There may be a few others with which I am not familiar.

A second way of evaluating equipment vulnerability is with a fiber simulator. If the electronics or equipment has a limited number of nodes, 50 or perhaps no more than 100, it is possible to probe this equipment and determine whether or not the fiber as simulated will produce a hazard, cause the equipment to malfunction, or burn out because of the power supply characteristics in the equipment.

The third method is what some people call engineering judgment, others call guesses, and I call generic similarity. That is, if your tests are performed on one type of computer of a given complexity and there is another of about the same complexity and the same technology, one could hazard some guesses with regard to its vulnerability.

The last method is called modeling and is outlined in figure 4. Even for equipment which may be as simple as a home television set, it is probably impossible to just look at the case and hazard

VULNERABILITY MODELING

1. ANALYZE EQUIPMENT INTO DEFINABLE UNITS USING FAULT TREES AND SEPARABLE CHARACTERISTICS.
2. FOR EACH UNIT:
 - A) TYPE OF VENTILATION (CONVECTIVE, FORCED, LEAKAGE)
 - B) TYPE OF TECHNOLOGY (VACUUM TUBE, DISCRETE, INTEGRATED)
 - C) VOLTAGE RANGE (< 15V, 15-200V, > 200V)
 - D) TYPE OF WIRING (CIRCUIT BOARD, SOLID WIRE) & CONNECTORS (SPADE LUG, HERMETIC, WIRE WRAP)
 - E) ORIENTATION OF OPEN LEADS & CIRCUIT TRACES
3. USE GENERIC TEST DATA ON CIRCUIT BOARDS & CONNECTORS TO ESTIMATE FAILURE STATISTICS.
4. COMBINE, USING FAULT TREE, INTO OVERALL FAILURE RATE PREDICTION.

STATUS: PRELIMINARY LOGIC MODEL DEVELOPED

Figure 4

a guess as to its vulnerability. One way of breaking it down into things that can be handled is to break the equipment down into definable units using the fault trees and the characteristics of the individual units which make up the tree. Then each type of smaller unit could be analyzed at that level: the type of ventilation, the type of technology, the voltage range of the equipment, the type of wiring that might be in it, the orientation of the open leads and circuit traces, and whether or not there are open leads or coated circuit boards can be considered. Then, using generic test data on similar circuit boards and connectors, the statistics of failures of each of those parts can be combined into an overall failure rate prediction. We have not done very much with this other than develop a preliminary logic model. Other people that have worked in this area have used this type of modeling in order to model a complete radar system for example.

Figure 5 is a computer-generated experimental vulnerability result. The testing was done on a PDP-11 computer, and it is a plot for tests that were done at 7.8 and 4.5 millimeter length fibers. Each of the staircase steps is at least one failure and generates the approximate probability of damage curve when plotted against the exposure in particle seconds per cubic meter. The shape of this curve is typical. It is not the best fit that has been secured, but it is typical and is fitted by the equation shown on the upper left where the probability of damage is shown

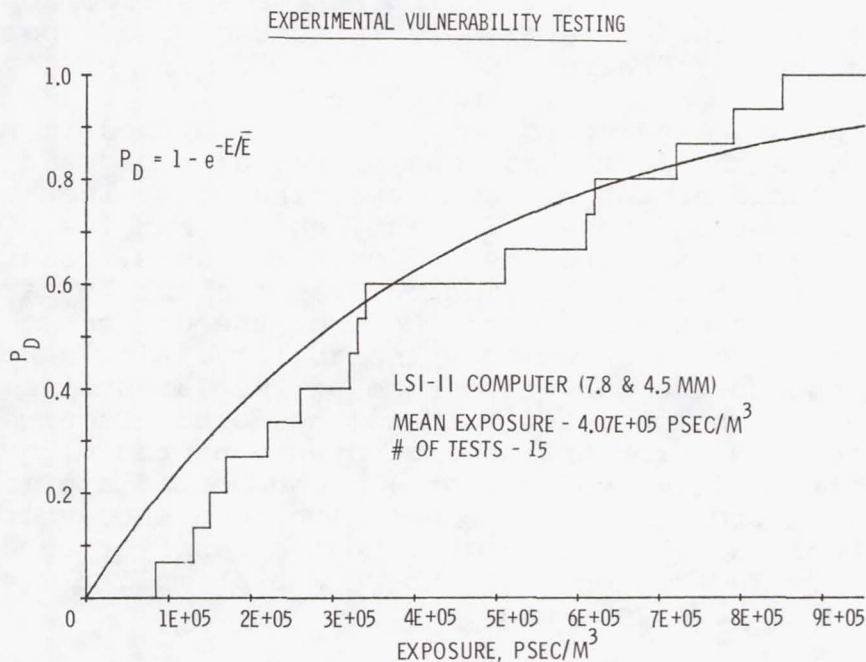

Figure 5

as an exponential. Figure 6 shows typical vulnerability results. The lengths of the test fibers are defined by 'short', 'medium', 'long'. The reason for this is that it is very difficult to cut the same length of 3 millimeter fibers so that testing might have been done anywhere from $2\frac{1}{2}$ to $3\frac{1}{3}$ millimeters, the 7 millimeter testing perhaps plus or minus a millimeter, and the long testing may be from 10 to 14 millimeters.

The small desk type computer, the PDP-11, was most vulnerable to the longer fibers in those tests. The vulnerability was approximately 10^5 and for the long and the medium lengths. The computer was a little bit less vulnerable to the shorter lengths, with \bar{E} at 10^6 . It is interesting that the first two items on this chart are both cooled with unfiltered fan-forced air, and neither one of the devices has coated circuit boards.

The next item on the figure is a color television which just barely came into our definition of vulnerable equipment. We essentially stopped testing at about 10^8 . If one puts any reasonable exposures and damage numbers into the problem of the national risk analysis, 10^8 turns out to be a vulnerability level which results in very small amounts of potential money loss. However, we still carry along in our risk estimates those devices which fail at 10^7 .

The rest of the equipment seems to be vulnerable at \bar{E} from about 10^5 up through about 10^7 . The smallest number on the chart, 2×10^4 , occurs for the very long fibers for a stereo amplifier. There is more of this data available in some of the reports which are not being presented here.

One of the outstanding things that has happened in the last period of time is the fact that many pieces of equipment were tested with a large number of them appearing not vulnerable. Figure 7 lists some of these. In fact, enough samples of consumer equipment were selected, such as radios, recorders, home music systems, etc. that they became indicative of about 75 percent of the available goods on the market. Most of the devices that have been tested so far have shown no vulnerability. It is believed that this is due to the fact that some of the latest items are somewhat newer technology, low wattage and do not require a cooling ventilation. No problems have been encountered with 110 volt electric motors and two thermostats. A number of appliances have been tested with probes. No problems have been encountered except in one case where a fiber would short out a resistor-capacitor timing circuit. In that one case there was a small timing error but no particular hazardous condition.

VULNERABILITY RESULTS - VULNERABLE

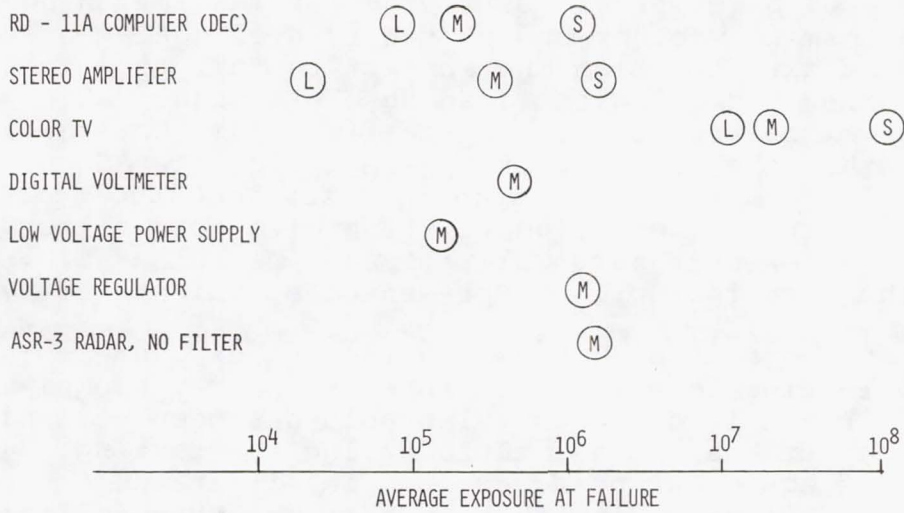

FIBER LENGTHS: (S) SHORT (~3 MM), (M) MEDIUM (~7 MM), (L) LONG (~12 MM)

Figure 6

VULNERABILITY RESULTS - NOT VULNERABLE

NOT VULNERABLE

- . AM/FM RADIO
- . CALCULATOR WITH PRINTER
- . TAPE RECORDER
- . HOME MUSIC SYSTEM
- . 10 BAND RADIO
- . ELECTRIC MOTORS 110V
- . 24V AND 115V THERMOSTATS
- . BLACK AND WHITE TV SET
- . DISHWASHER (PROBE TEST)
- . TOASTER (PROBE TEST)
- . CAR RADIO
- . GENERAL AVIATION DME
- . ASR-3 RADAR, WITH FILTER

Figure 7

The general aviation Distance Measuring Equipment (DME) was tested as one of a series of tests of general aviation equipment, to try to determine whether or not the type of equipment that might exist in light aircraft might be subject to failure. It did not fail. The ASR-3 radar, which is an obsolete radar, when tested with its normal filter as used in the field, did not fail. It is interesting that the radars that are replacing the ASR-3, which are now ASR-7's and 8's, and going into service have coated circuit boards and better control of ventilation with good filters. We believe that the newest radars will also not be vulnerable. That concludes the data that will be presented on vulnerability.

The next subject for discussion is post-exposure vulnerability. Most of the testing done to date has been done with equipment 'on', and whether or not it has been vulnerable has been determined by whether or not it has had a failure during the testing. There is the problem of equipment being exposed in either an 'on' or 'off' condition not failing during the exposure and then failing in some period of time after the exposure. One way of thinking about the problem is to think about the fibers that enter the equipment as illustrated on figure 8. There is only a limited number of things that can happen to ingested fibers. They can be exhausted immediately, which I think is what happens to most of the fibers. They can cause a problem, in which case the equipment would be taken

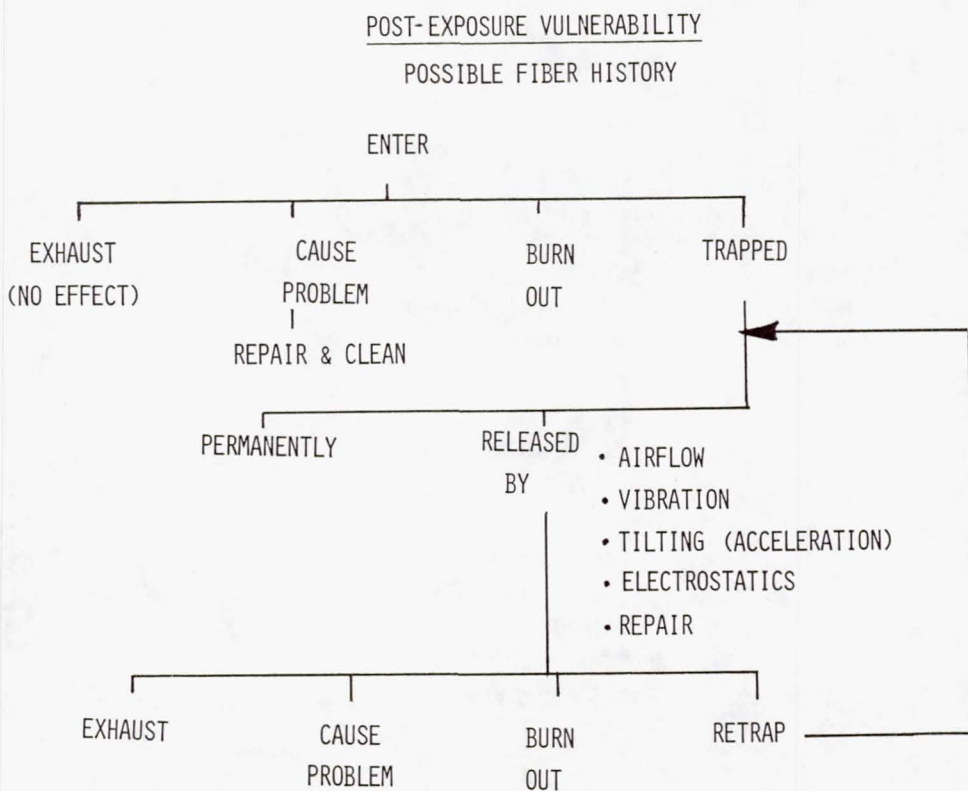

Figure 8

apart, would be repaired and cleaned and that would be the end of those fibers. They might burn out because of the voltage or power range in the equipment, or they might get trapped within the box. If they are trapped within the box they may get trapped permanently. Cases have been observed where it is extremely difficult to remove a fiber from its position in a box after exposure. The fibers could be released either by subsequent air flow, vibration, electrostatics (turning the equipment 'on' and 'off'), or by a subsequent repair that might have been occasioned by some other fault. The logic loop can be repeated many times and one can hypothesize that every operation results in working with less and less fibers. In an attempt to see whether or not this problem was worth studying, we did some preliminary pathfinder tests with two boxes.

Figure 9 outlines the test scheme. The color television and the stereo amplifier (for which vulnerability₅ data was presented within figure 6) were exposed to about $E = 10^5$ fiber seconds per cubic meter. They were given nine exposures in an 'off', and nine exposures in an 'on' state with the supposition that there was a possible electrostatic effect that could determine where the fibers might land and might adhere. A year's operation was then simulated after each exposure. These tests are very time consuming. They took about 200 hours of testing, yet it is apparent that we really did not simulate the number of on-off switches that

POST-EXPOSURE VULNERABILITY

TEST METHOD

- . FIBER EXPOSURE 10^5 FIBER SECONDS/METER³
- . NINE EXPOSURES IN "OFF" + NINE IN "ON" STATE
- . SIMULATE ONE YEAR'S OPERATION AFTER EACH EXPOSURE
 - 100 ON/OFF SWITCHES (EACH TWO MINUTES)
 - 50 PHYSICAL MOVEMENTS
 - 50 BLOWER OPERATIONS

RESULTS

- . NO POST-EXPOSURE FAILURES CAUSED BY GRAPHITE FIBERS FOR COLOR TV OR STEREO AMPLIFIER

Figure 9

occur in a normal television in a year. The 50 physical movements is probably about right, and the lower operations where opened windows or fans were simulated are reasonably realistic.

Results to date are that no failures have occurred on either box. This work will continue with some more devices but so far the results look promising. It may not be a big problem.

Figure 10 offers conjectures with respect to the effects of future technology. Some of this technology is already in use and the effects are apparent in the testing of consumer appliances. I believe there will be more coated circuit boards than at present. One of the reasons for this is that manufacturers are beginning to do wave soldering and it is economical to coat the board in order not to waste solder. There is an increased use of integrated circuits as compared to discrete items, therefore less leads, lower power requirements, and no need for cooling openings into the case. When people build equipment nowadays they are more sensible about specifying filters. This seems to be particularly true of field equipment such as being specified by the FAA for airport use. Improved ventilation practices in general, in homes and in offices, should improve the situation; the only thing that looks a little black is the tremendous rate of increase of the amount of electronics in use.

FUTURE TECHNOLOGY EFFECTS ON VULNERABILITY

	<u>REDUCES</u>	<u>INCREASES</u>
INCREASED USE OF COATED CIRCUIT BOARDS	X	
INCREASED USE OF INTEGRATED CIRCUITS	X	
LOWERED POWER REQUIREMENTS	X	
IMPROVED FILTRATION SPECIFICATIONS	X	
IMPROVED VENTILATION PRACTICES	X	
MORE ELECTRONICS IN USE		X

Figure 10

One more subject which has not previously been discussed is the potential of a shock hazard. Figure 11 diagrams how 110 volt power is conducted into a normal home or office. There are usually three leads, a "hot" lead at 110 volts, a neutral lead which is usually at the same potential as ground, and a ground lead. When these come into the home, and an appliance of any kind is plugged in, and if a cheater plug is not used, then the external case is connected to ground. The neutral lead and the hot lead enter the case and either a one pole or a two pole switch makes the connection to the internal circuit.

If fibers are ingested into the case there is a potential short between the wiring in the case and the case. If a human being touches the case and has a resistance to ground, he completes the circuit through himself from the 110 volt source.

Figure 11 also lists some typical resistivities resulting from barely touching a case with everything dry, in which case the resistance is in megohms, to touching it with various degrees of wetness and area. For each of these contacts with different resistivity, the current through the human being can range all the way from where he might feel a mild shock to where he can be at a "no-let-go" condition (no voluntary control over the muscles). In fact, at 30 milliamperes he may be subject to ventricular fibrillation.

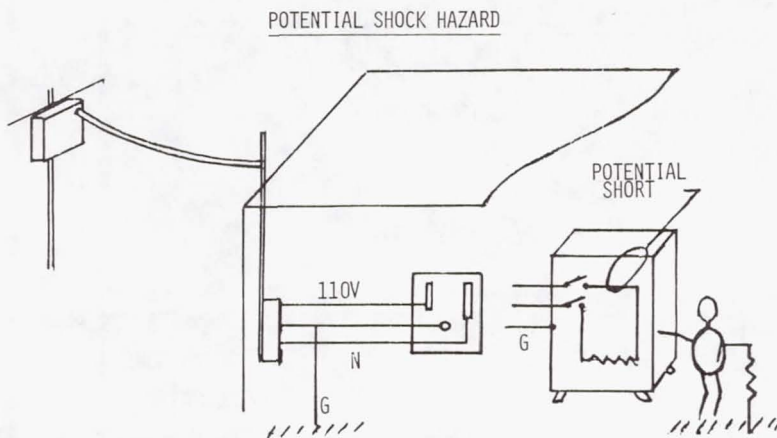

<u>CONTACT</u>	<u>RE: OHMS</u>	<u>CURRENT AMP</u>	<u>EFFECT</u>
DRY, TOUCH CASE	MEGOHMS	-	NONE
DRY, FINGER-THUMB GRASP	30 K	.003	MILD
WET, FINGER TOUCH	20 K	.005	ANNOYANCE
DRY, HAND HOLDING PLIER	10 K	.009	"NO-LET-GO"
DRY, PALM TOUCH	3 K	.030	VENTRICULAR FIBRILLATION
FOOT, ON DAMP LEATHER	12 K	.009	"NO-LET-GO"
FOOT, ON WET CONCRETE	1 K	.110	FIBER BURNS OUT

Figure 11

lation. There are really very few appliances that are of concern. Electric heaters and some metallic-cased small electric tools offer some hazard; however, the most serious concern is the familiar home toaster. It is believed that the toaster is the biggest problem that exists because of the large numbers in use.

Figure 12 lists some assumptions which were made to determine whether further work in this regard is needed. It was assumed that there are 2000 pounds of fiber in each of five fire-accompanied accidents per year, that ten percent of the graphite fiber was released, that there are a thousand people per square kilometer (typical of many urban areas), and that the average everyday family has a toaster, with three people in a family. A 0.01 transfer function from the outside to the inside of the home was also assumed; however, 0.01 may be a little bit large with respect to computed transfer functions into a home with windows and doors closed. The transfer function could be unity if the home had wide open windows or doors.

The determination of the hazard is made by applying an estimation formula which includes: the probability of a shock hazard as linearly related to the density of the toasters per unit area; the transfer function into the enclosure where the toaster exists; an inverse proportion to the \bar{E} necessary to produce the shock hazard; a direct proportion to the number of fibers that are re-

PRELIMINARY ESTIMATE OF TOASTER SHOCK HAZARD

ASSUMPTIONS

- 2000# FIBER IN EACH OF 5 FIRE ACCIDENTS/YR
- 10% FIBER RELEASE
- 1000 PEOPLE (330 TOASTERS) PER KM²
- 0.01 TRANSFER FUNCTION, OUTSIDE TO TOASTER

$$P_{\text{SHOCK HAZARD}} = \left(\frac{\text{TOASTERS}}{\text{AREA}} \right) \left(\frac{\text{T.F.}}{\bar{E}} \right) \left(\frac{N}{V_s} \right), \quad \text{WHERE:}$$

- T.F. TRANSFER FUNCTION
- N, TOTAL NUMBER OF FIBERS RELEASED
- V_s FALL VELOCITY
- \bar{E} , AVERAGE EXPOSURE WHICH CAUSES A SHORT

$$P_{\text{SHOCK HAZARD}} = \left(\frac{330}{10^6} \right) \left(\frac{10^{-2}}{10^8} \right) \left(\frac{10^{12}}{2 \times 10^{-2}} \right) = 1.6 \text{ POTENTIAL HAZARDS/YEAR}$$

(FOR $\bar{E} = 10^8$ TOASTER)

$$\left(= 1600 \text{ (FOR } \bar{E} = 10^5 \text{ TOASTER)} \right)$$

NOTE: 10^8 AND 10^5 DETERMINED WITH 7 MM FIBERS.

Figure 12

leased in the accident; and an inverse proportion to the fall velocity of the fibers.

This formula for integrated exposure has been checked a number of times against specific footprints that have been computed and it is a good conservative estimator. If the footprint covers a uniformly settled area, it will provide a conservative estimate of the amount of damage. This formula is similar to one expression used to calculate dissemination footprints. Two toasters were tested. There were actually three submitted. One toaster that was tested required an \bar{E} of about 10^8 in order to produce a shock hazard; and, if all the correct numbers are applied to the formula, it computes about 1.6 potential hazards per year for that toaster. The second toaster that was tested has an \bar{E} of 10^5 . That equates to be about 1600 potential hazards per year. That does not mean that there is a hazard. There is a potential hazard. The accompanying proper resistivity of the human being to do some damage is required as well. We did check the third toaster, but interestingly enough, it required an \bar{E} of zero because it was shorted when submitted to the laboratory. These tests were all done with 6 millimeter fibers. These tests will be repeated with shorter fibers. The computations show values large enough so that we have to further analyze the problem.

Figure 13 lists some reasons for believing that the computed

PRELIMINARY SHOCK HAZARD CONCLUSIONS

1. THE RISK IS LOWER THAN ESTIMATED FOR THE ' 10^5 TOASTER':
 - A) LATEST SOURCE DATA INDICATES SHORTER FIBERS ARE PREDOMINATE IN RELEASE SPECTRUM.
 - B) NEW SAFETY STANDARDS ISSUED IN 1973 REGARDING TOASTER CONSTRUCTION.
 - C) ONLY 10 TO 50% OF TOASTERS IN USE ARE OF 10^5 TYPE.
 - D) SIMULTANEOUS PROBABILITY OF REQUIRED HUMAN RESISTANCE TO GROUND IS LOW.
 - E) PLUG MUST BE INSERTED SUCH THAT HAZARD IS PRESENT.
2. ADDITIONAL EFFORT IS REQUIRED:
 - A) SECURE MORE DATA REGARDING SHOCK HAZARD VS. EXPOSURE VS. FIBER LENGTH
 - B) SECURE MORE INFORMATION REGARDING USE RATE AND OBSOLESCENCE OF TOASTERS.
 - C) COMPUTE NATIONAL RISK USING DETAILED RISK ANALYSIS METHODS.

Figure 13

hazard is probably too large. The latest source data indicates that shorter fibers are predominate in the release spectrum. I believe that the shock hazard is probably less than indicated for the shorter fibers. The second item is that there were new safety standards introduced in 1973 regarding toaster construction. We really do not know how many are out in the field of each type. Estimates were made by some people at the Bureau of Standards Consumer Safety Group; they estimated that for the toasters considered susceptible they would guess only 10 to 50 percent of the ones in use are of that type. Perhaps there is one other small factor, and that is that the plug must be inserted so that the hazard is present.

Possibly the biggest safety factor of all is that whatever number is computed by the methods shown must be multiplied by the simultaneous probability of getting the right human resistance to ground. We honestly do not know the probabilities for this event. More data is required regarding the shock hazard versus exposure and fiber length. More data regarding the use rate and the obsolescence of toasters is also needed. Apparently the newer ones may be safer. Finally the national risk should be computed using detailed risk analysis methods rather than the kind of estimating scheme shown.

Figure 14 shows work that is planned. There is a specific

PLANNED EFFORTS

VULNERABILITY TESTING

APPLIANCES & ADVANCED ELECTRONIC CONTROLS

CONSUMER EQUIPMENT

INDUSTRIAL EQUIPMENT

AIRCRAFT EQUIPMENT

GENERIC TESTING:

. CONNECTORS

. CIRCUIT BOARDS

. TYPICAL COMPONENT INSTALLATIONS

VULNERABILITY MODELING

Figure 14

worry about appliances that may show up on the market with advanced electronic controls. Some tests are planned on consumer equipment, industrial equipment, and on aircraft equipment. Testing is being accomplished and will continue on particular types of connectors and circuit boards. Vulnerability models are being developed so that it will not be necessary to test every electronic box in the country.

A few conclusions from the work that has been done so far are shown on figure 15. It is not difficult to take any specific box or any specific installation and do the necessary experiments and evaluate that particular installation. However, it still looks fairly difficult to do a national risk estimate because of the difficulty of modeling things such as complete industries in terms of what kinds of equipment they have and how much they may have in a plant. It is believed that the use of new technology will tend to reduce the risks because of the smaller size, the better encapsulation and the lower wattage. To date no problems have been encountered with any 110 volt equipment (motors, appliances) and none are expected unless electronic controls are used. This is primarily because with the 110 volt equipment in general use when the fibers cross a pair of nodes, they will burn away. The testing that has been done so far of a sample of consumer electronics indicates very little vulnerability. In fact none were found in the group that was tested. More work is indicated on the toaster shock hazard analysis in order to determine whether a serious problem exist.

PRELIMINARY CONCLUSIONS

1. ANY SPECIFIC INSTALLATION CAN BE EVALUATED FOR RISK WITH AVAILABLE TEST & ANALYSIS CAPABILITY, HOWEVER;
2. TO SECURE CONFIDENCE IN A NATIONAL RISK ANALYSIS ADDITIONAL TESTING & MODELING IS REQUIRED.
3. USE OF NEW TECHNOLOGY WILL TEND TO REDUCE THE RISK.
4. NO PROBLEMS HAVE BEEN ENCOUNTERED TO DATE WITH 110V EQUIPMENT (MOTORS, APPLIANCES) AND NONE ARE EXPECTED UNLESS ELECTRONIC CONTROLS ARE USED.
5. TESTS OF A SAMPLE OF CONSUMER ELECTRONICS INDICATE LITTLE VULNERABILITY.
6. PRELIMINARY TOASTER SHOCK HAZARD ESTIMATES INDICATE ADDITIONAL EFFORT IS REQUIRED.

Figure 15