

NASA CONFERENCE PUBLICATION

NASA CP-2084

LASER DOPPLER VELOCIMETRY WORKSHOP

The Summary of a Workshop Held February 12, 1979
at Marshall Space Flight Center

Robert B. Owen
Space Sciences Laboratory

March 1979

Prepared by
NASA - George C. Marshall Space Flight Center
Marshall Space Flight Center, Alabama 35812

LASER DOPPLER VELOCIMETRY WORKSHOP

A workshop on Laser Doppler Velocimetry was held at Marshall Space Flight Center on February 12, 1979. (An agenda is included in the Appendix.) The purposes of the workshop were to investigate the potential of laser doppler velocimetry (LDV) as a technique to use in mapping flows in the several fluid systems under development by NASA for doing research on low-g processes, to familiarize the appropriate MSFC personnel with LDV, and to answer certain questions which have repeatedly arisen in our previous investigations of LDV techniques. These questions will be specifically addressed in this report, after some general statements concerning LDV.

Laser doppler systems measure the local, instantaneous velocity of tracer particles. This means that the relationship between the flow of interest and the particle velocity must be known. Appropriate particles often already exist in many liquids and gases, and more can generally be added if needed.

The most common optical arrangement used in laser doppler studies is the dual beam mode (Figure 1). The dual beam or fringe system uses two intersecting light beams of equal intensity to produce a pattern within their volume of intersection. As each particle crosses the fringes, the intensity of light scattered onto a photodetector rises and falls at a rate directly proportional to the velocity.

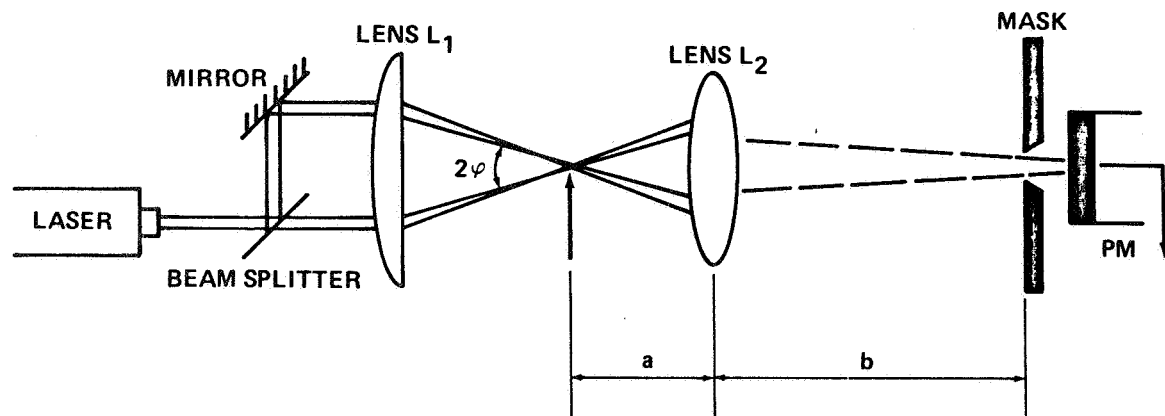

Figure 1. Basic optical arrangement for "dual beam anemometer."

There are several other optical arrangements which can be used. In the reference beam mode (Figure 2), the laser beam is split into an intense incident beam and a weak reference beam. The reference beam is directed onto a photocathode where it beats with light scattered from the strong beam by particles moving with the flow; the frequency of the scattered light has been altered by the doppler effect, and the interference with the reference beam provides a frequency difference which is directly proportional to the particle velocity.

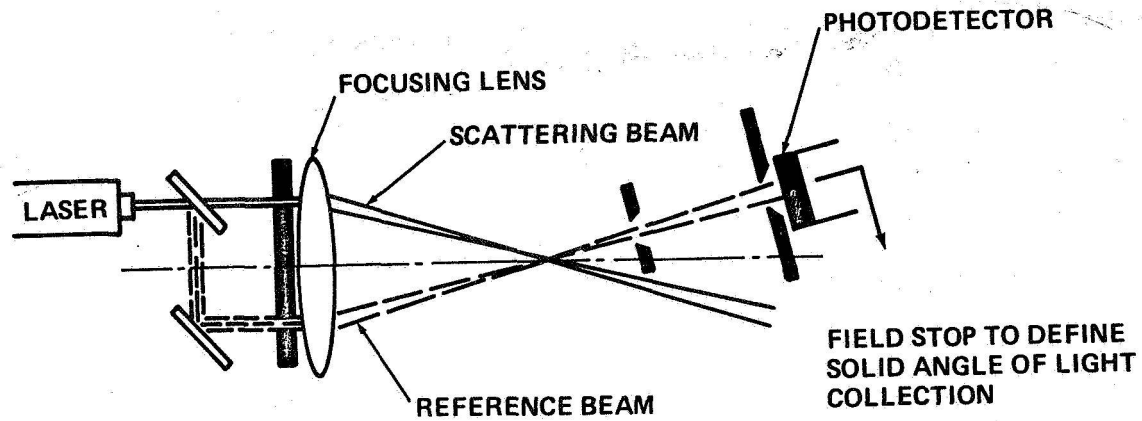

Figure 2. Basic optical arrangement for "reference-beam anemometer."

In the two-scattered beam or differential doppler mode (Figure 3), a single focused laser beam is directed into the flow, and light scattered by a particle in two directions is collected symmetrically about the system axis. When the scattered beams are combined, the relative phase of their wave fronts depends on the distances of the particle from each light collecting aperture; hence as the particle moves across the beam, the scattered light beams interfere constructively and destructively, leading to a light intensity at the photocathode which fluctuates at the doppler frequency. This system offers no clear advantage over the fringe mode other than its use in measuring simultaneously two velocity components by collecting pairs of scattered beams in mutually perpendicular planes.

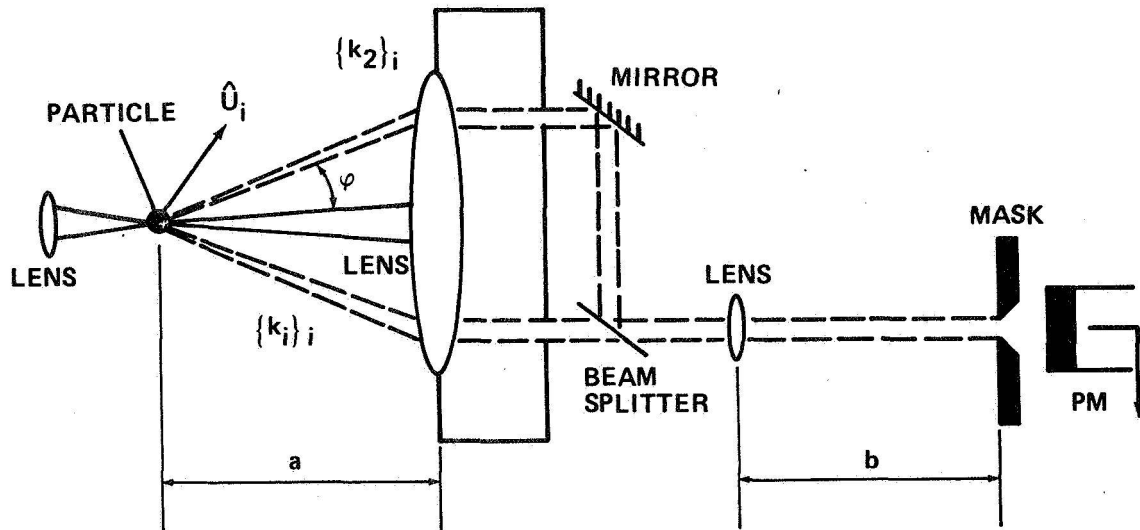

Figure 3. Basic optical arrangement for "two-scattered beam anemometer."

In a fourth optical arrangement, two beams are focused to two separate spots in space. This forms the basis of the "two-spot" system (Figure 4) which is currently being developed at Spectron Development Labs by J. Trolinger and associates. This system can be interpreted as the Fourier transform of LDV. A tracer particle traveling from one spot to another scatters at each point; the spots are made as small as possible (for example, 10-micron spots separated by perhaps 100 microns), and the scattered signals are correlated to eliminate erroneous data. The resultant signal/noise ratio is 100 to 1000 times better than that in standard systems. This arrangement is, therefore, suited for very small particles or for a case in which test cell geometry precludes the use of a dual-beam arrangement. The spots can be rotated about the optical axis by use of a dove prism; one can then specify the velocity vector (in the plane perpendicular to the optical axis) by rotating the spots until the correlation function is maximized. The improved system signal/noise ratio is realized primarily because the scattered light is more intense due to the focused beams and because the spots can be imaged on two separate photomultiplier tubes. There is a slight velocity error (approximately 0.2 percent) which arises from tracer particles passing through different parts of the spots. It should be noted that the correlation technique requires time, typically 3 to 20 seconds, or even several minutes under extreme conditions such as very low tracer particle densities. Also, standard LDV geometries are better for turbulent flow measurement. However, the two-spot geometry is superior to standard geometries near a boundary.

A variation of LDV which was discussed at the workshop (mostly by M. Farmer and J. Mann) involved use of a fluorescent LDV probe. Such a system would use molecules which would fluoresce in the laser beam as tracer particles. If used in an ordinary dual-beam LDV system, the molecules would fluoresce on and off as they crossed the fringe pattern. It would be possible to adjust the structure of the molecules (surfactants) so they would accumulate at surfaces, thus making it possible to distinguish between bulk and surface flows. Another possibility would be to use a two-dimensional Bragg cell to generate two sets of moving fringes. Such a system would use well-established dual-beam LDV technology and would eliminate many of the problems which sometimes arise from stray laser light.

All the system geometries discussed can be employed with either forward or backward scattered light, but most measurements are made with forward scattering since this signal is much more intense (by a factor of about 1000) for scattering particles of the size used to represent fluid velocities.

Some sort of signal processing system such as spectrum analyzer or frequency tracker must be utilized since a large number of particles must be

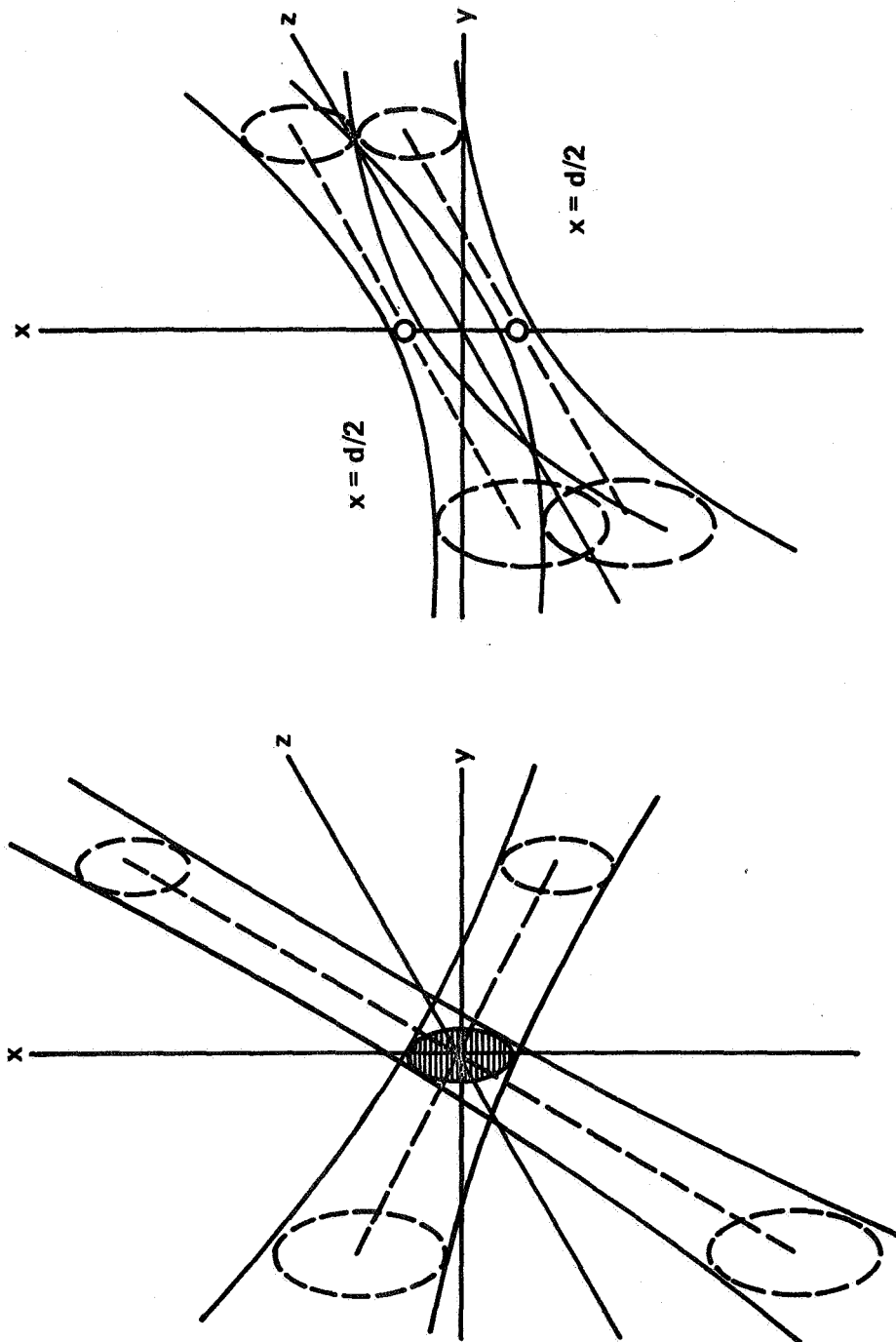

Figure 4. Schematic of fringe and transit illuminated volumes.

observed to obtain reliable results. In most flow configurations, low particle concentrations preclude averaging with continuous signals. As a result, electronic devices are required to control the intermediate signal output when no doppler signal is present. Devices of this sort must be scrutinized with care. Another problem common to all methods of signal analysis is posed by reverse flow, as found in regions of high turbulence. The doppler frequency is related to the velocity but does not reflect the direction of flow in a given line. This is commonly allowed for by using optical frequency shifting devices to change the frequency of one beam and so displace the doppler frequency corresponding to zero velocity from zero to a finite positive value, thus providing the sign of the measured velocity. As a result, a carefully selected range of instruments is normally required to obtain useful information in different flows.

It is also important to have information on the size and size range of the light scattering particles before an optical system is designed, since the relative magnitude of the modulated and unmodulated components of the light scattered from a particle depends on the size of the particle and the ratio of this size to the fringe spacing. Water normally contains ample suitable particles, but air and most gases do not. More important in many applications is the extent to which particles of different diameter and density will follow the flow. For example, a 1-micron diameter dust particle will follow frequencies up to about 10 kHz in air with a precision of 1 percent; if the particle size is 10 microns (dia), the frequency response drops to 700 Hz. Clearly, particle size data is critical to successful LDV studies.

In general, the need to match the components of an LDV system to each other and to the flow configuration cannot be overemphasized. Provided this is done, LDV systems are precise, economical, and easy to use. Many measurements cannot be made any other way.

We are now in a position to make some specific comments on questions which have repeatedly arisen in our previous investigation of LDV techniques.

1. What are the measurement capabilities of LDV in ultrapure materials which do not contain added tracer particles? Must spatial and/or velocity resolution be sacrificed?

To obtain conditions in which molecular scattering predominates, it is sometimes necessary to filter for months. Under such ultrapure conditions, LDV probably could not be used unless the material would fluoresce in the laser beam. However, particles as small as 0.5 microns in diameter, which can be expected to occur naturally in our systems, would provide a perfectly adequate LDV tracer array.

By using an existing LDV system at Marshall (in the Fluid Dynamics Laboratory, Space Sciences Laboratory), it was established that an LDV signal could be obtained from a sample of R. Kroes' crystal growth solution prepared as for his ground study work. The solution used filtered distilled water, but clean-room conditions and elaborate filtering techniques were not attempted. It is almost impossible to maintain a fluid of this type in a condition that will not produce LDV signals. Spatial and velocity resolutions are tied to the fluid characteristics and the required data rate, not tracer particle size. However, a limiting factor might be refractive index gradients caused by thermal or density gradients which could cause the illumination beam to wander. Some modeling of the flow is necessary to determine the seriousness of this problem.

2. What sizes and densities of tracer particles are required to measure submillimeter/second flows ?

Some elementary computations performed during the workshop led to the conclusion that particles as small as 0.2 micron in diameter would be sufficiently large not to be adversely affected by Brownian motion. No upper limit is required on such tracer particles in this type of fluid for low velocities. The size of the tracer particle required depends critically upon the specific laser velocimeter system used. Generally speaking, for particles 0.5 micron in diameter and smaller, a forward scatter laser velocimeter would be required unless a photon correlation may permit use of a backscatter system. The required number density of particles is closely connected to the required data rate.

3. What configurations are most suitable for mapping a flow field? What are the tradeoffs for measuring three directional components of the flow, versus two components, versus one component?

The most suitable configuration for mapping a flow field such as this is a backscatter system because traversing and scanning can be accomplished with zoom lenses and scanning mirrors. This problem must be traded off against the required tracer particles and laser power. There was general agreement during the workshop that a compromise was required to make this system practical. The compromise would include such things as reducing the measurement to a one- or two-component velocity measurement with mapping limited to a few line scans through the flow field. The possibility of producing an array detection system was discussed, and it would be possible to use an array of probe volumes with the same set of electronics serving several directional components and probe volumes. This seems to be a highly practical and desirable configuration. Also, the Fourier transform analyzer described by M. Fingerson offers a method of simplifying the electronics.

It is very difficult to measure a three-dimensional flow field from a single position. Such a measurement would probably require a separate system oriented at 90 degrees to the basic measuring system. The benefits of such an arrangement are rather dubious. A two-dimensional system is relatively straightforward, but even two-dimensional scanning would require considerable hardware and sophistication. It is possible to design a system which could be one or two dimensional as required.

4. What resolution can be expected from an LDV system ?

Again, specific answers are highly dependent on the available particle size and number density distribution in the fluid. However, a spatial resolution of 100 micrometers should be easily obtained, with 10 micrometers a possibility, assuming no significant refractive index gradients. Specific information about the experimental fluid must be available to discuss this question.

5. How accessible must the test zone be for these various configurations to be effective ?

The accessibility of a test zone and the locations and sizes of the various optics depend critically upon the particle size and number density distribution as well as upon the required data rate in the measurement. The required data rate also depends critically upon the type of signal processing used.

6. Is it feasible to measure flows in opaque materials such as molten metals using surface reflections, optical fiber probes, etc. ?

Surface measurements are possible using a dual and/or reference beam LDV configuration.

In summary, LDV appears suitable for making flow measurements in our fluid systems provided that the systems are adequately defined, the flows are not dominated by transients, and the system contains no significant variations in refractive index. More detailed discussion of these three problem areas follows.

As was repeatedly emphasized during the workshop, it will be necessary to specify our measurement requirements to specify system design parameters. Because the LDV configuration must be matched to the experiment to obtain optimum results, it is difficult to design a general purpose LDV system which will operate at maximum capacity for all fluids experiments. However, it is probably possible to design an LDV system which will yield adequate results for most experimental configurations. To insure this, it will be necessary to do

ground-based studies to avoid relying on the LDV system to measure every unknown during flight. One such approach would be to do a computer study of the fluid dynamics of each experiment and check the computer results on the ground. When the experiment is flown, one need only make measurements in areas which the computer results indicate are critical. This will reduce the measurement requirements as mentioned previously (question 3). One then has a well-defined experiment with a greatly simplified LDV system. Such an approach should be within the capabilities of current LDV technology.

Because LDV measures velocities only at a point, transient flows are difficult to measure using this technique. If the flows contain significant transients, it is desirable to map the entire flow field, which is difficult to do rapidly using LDV.

LDV always involves two unknowns, the tracer velocity and the integrated refractive index over the light paths in the fluid. At the low velocities expected in our fluid systems a knowledge of refractive index variations becomes more critical. Most applications of LDV involve systems with a constant refractive index. If the fluid systems have varying and unknown refractive indices, LDV cannot be accurately applied.

Thus while low velocities and tracer particle requirements should present no problems in making LDV measurements, there are problems in current measurement requirement definition, flow field visualization, and possible fluid refractive index variations. For these reasons it has been decided not to baseline LDV for the first fluid experiment system. The technique is, however, quite promising for later experiments. Some type of time-exposure photographs of tracer particles would probably be more feasible for initial experiments.

APPENDIX

LDV WORKSHOP AGENDA February 12, 1979 Main Conference Room/ Building 4481

Chairman: J. Williams

8:30	MPS Fluid Systems Overview	R. Ruff MSFC
9:00	The Limits of Low Flow Speed Measurement with LDV	W. Fowlis MSFC
9:30	Applications of LDV at AEDC	T. Bentley AEDC
10:00	Typical LDV Configurations	D. Reed Texas A&M
10:30	Surface and Bulk Flows by LDV	J. Mann Case Western
11:00	Lunch	
12:00	Low Velocity LDV Measurements and Particle Size Requirements	R. Adrian U. of Ill. (Urbana)
12:30	Particle Measurements and Particle Requirements in Sub-mm Flow and Surface Velocity Measurements	M. Farmer UTSI
1:00	Instrumentation for Application in Extremely Low-Seeded Cases	J. Trolinger Spectron Development Labs
1:30	An Example System for Measuring Low Flow Velocities	M. Fingerson Thermo-Systems
2:00	Comments Concerning LDV Applicability to Solution Crystal Growth	R. Kroes MSFC
2:30	Discussion and Comments	

APPROVAL

LASER DOPPLER VELOCIMETRY WORKSHOP

By Robert B. Owen

The information in this report has been reviewed for technical content. Review of any information concerning Department of Defense or nuclear energy activities or programs has been made by the MSFC Security Classification Officer. This report, in its entirety, has been determined to be unclassified.

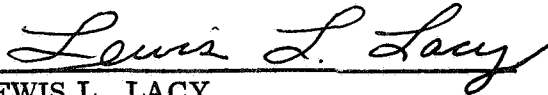

LEWIS L. LACY
Chief, Solid State Branch



ROBERT J. NAUMANN
Chief, Space Processing Division

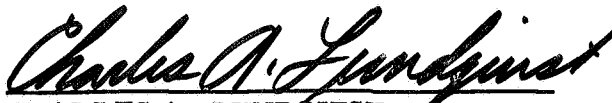

CHARLES A. LUNDQUIST
Director, Space Sciences Laboratory

1. REPORT NO. NASA CP-2084	2. GOVERNMENT ACCESSION NO.	3. RECIPIENT'S CATALOG NO.	
4. TITLE AND SUBTITLE Laser Doppler Velocimetry Workshop		5. REPORT DATE March 1979	6. PERFORMING ORGANIZATION CODE
		8. PERFORMING ORGANIZATION REPORT #	
7. AUTHOR(S) Robert B. Owen	9. PERFORMING ORGANIZATION NAME AND ADDRESS George C. Marshall Space Flight Center Marshall Space Flight Center, Alabama 35812		
12. SPONSORING AGENCY NAME AND ADDRESS National Aeronautics and Space Administration Washington, D.C. 20546		10. WORK UNIT NO.	11. CONTRACT OR GRANT NO.
		13. TYPE OF REPORT & PERIOD COVERED Conference Publication	
		14. SPONSORING AGENCY CODE	
15. SUPPLEMENTARY NOTES Prepared by Space Sciences Laboratory, Science and Engineering			
16. ABSTRACT A workshop on laser doppler velocimetry was held at Marshall Space Flight Center on February 12, 1979. The main purpose of the workshop was to investigate the potential of laser doppler velocimetry as a technique to use in mapping flows in the several fluid systems under development by NASA for doing research on low-gravity processes. This summary presents the results of the workshop.			
17. KEY WORDS	18. DISTRIBUTION STATEMENT Unclassified -- Unlimited <i>Robert B. Owen</i>		
19. SECURITY CLASSIF. (of this report) Unclassified	20. SECURITY CLASSIF. (of this page) Unclassified	21. NO. OF PAGES 12	22. PRICE NTIS