

HELICAL GRIP FOR THE CABLE CARS OF SAN FRANCISCO

By Richard J. Peyran
NASA-Ames Research Center

ABSTRACT

A Helical Cable Car Grip to minimize high maintenance costs of San Francisco's cable car operation is presented. The grip establishes a rolling contact between the cable and grip to reduce sliding friction and associated cable wear. This paper describes the design, development, and testing of the Helical Cable Car Grip.

INTRODUCTION

The San Francisco cable cars (Figure 1) currently utilize a manually operated mechanical grip to force two replaceable soft steel dies against a 3.33 cm (1.31 in.) diameter cable to accelerate the car from rest to cable speed of 4 m/s (9 mph). Friction between the cable and dies creates high temperatures and rapid wear resulting in a die life of 3-4 days and a cable life of 3-4 months. Associated maintenance costs are \$500,000 per year.

A joint effort of the NASA-Ames Research Center and Stanford University created a design for a cable car grip that minimizes maintenance costs while preserving the traditional appearance and operation of the cars. The 10,900 Kg (24,000 lbm) cable cars climb 21% grades at speeds from 0 to 4 m/s (9 mph) and accelerate at 0.1 g. The grip mechanism must release and re-engage the cable at cable intersections and operate within the confines of the cable conduit under the street.

GRIP DESIGN

This study concentrates on the design of the cable gripping mechanism which operates below the surface of the street. The Helical Grip design reduces sliding friction and cable wear compared to the existing grip. Drive wheels are grooved with a helical pattern that meshes with the lay of the cable in a manner similar to a worm and gear set. The cable is gripped between the drive wheels and guide rollers (Figure 2) and the cable car pulled along as the rotation of the drive wheels is slowed by hydraulic clutches. The drive wheels maintain rolling contact with the cable without the wear-producing slippage of the soft steel dies. The meshing action between the drive wheels and the cable enhances the gripping ability and reduces the clamping forces needed to maintain the wheel's grip on the cable. Without the helical grooves, the clamping force required to prevent slippage between the drive wheels and cable is so great that cold rolling of the cable would occur.

The complete grip (Figure 3) uses four drive wheels 10.7 cm (4.2 in.) in diameter. Two hydraulic wet clutches brake each drive wheel. The clutches are a multiple plate type with an oil film separating the individual plates. Fluid shear brakes the drive wheels as the plates are forced together. Metal to metal contact of the plates occurs only when the drive wheels are locked (fullgrip). To operate the clutches, a 0.4 hp hydraulic pump and oil reservoir are required to supply oil at a pressure of 1.03 MPa (150 psi). This pump could be located in the cable car away from the grip. A separate oil system to circulate oil through the clutch plates could be incorporated to facilitate heat removal. Sixteen guide rollers position the cable against the drive wheels and prevent separation between the cable and drive wheels while gripping the cable. Lift arms link the rollers with the shank plate (Figure 3). Downward motion of the shank plate presses the rollers tight against the cable. Upward motion of the shank plate retracts the rollers to allow the cable to drop away from the grip at cable intersections. Once passed the intersection, the grip may re-engage the cable.

MODEL TESTING

To determine if the Helical Cable Car Grip concept was feasible, a test plan examining the basic principles was needed. For a feasible design, the test needed to show that no slippage occurred between cable and drive wheel, that sufficient force, 32,000 N (7200 lbf), was developed to pull the cable car, and that the clutches lock the drive wheels against the cable. A prototype model to be tested under laboratory conditions was designed (Figure 4). The test model consisted of a single drive wheel, two clutches, and four pressure rollers which correspond to one-quarter of a full grip assembly. Two arms adjusted the pressure rollers by a threaded rod. Each clutch was actuated through a high pressure oil line and a lower pressure bleed was used for lubrication and cooling. The grip was bolted to the floor and remained stationary during the tests (Figure 5).

The drive wheel was cut to mesh with a 1.91 cm (0.75 in.) diameter cable. The helical pattern (Figure 6) was cut using a high speed milling cutter 0.95 cm (0.375 in.) diameter and 6.99 cm (2.75 in.) pitch on a helical gear cutting machine.

The test set-up (Figure 7) used a 15.3 m (50 ft.) loop of 1.91 cm (0.75 in.) diameter cable. The cable was made of six strands around a hemp core and was similar in construction to the 3.33 cm (1.31 in.) diameter cable in actual use but its smaller diameter allowed for a simpler test apparatus. A jack shaft assembly connected a 3 hp motor to the cable drive. A hydraulic pump with a 2.84 ℓ (0.75 gallon) reservoir supplied oil to the clutch assemblies.

Static tests on the grip model simulated the car moving at cable speed. The test was conducted by loading the cable with a manual winch to force it through the grip with the clutches engaged (Figure 8). Loads were one-quarter of full scale, 8000 N (1800 lbf), corresponding to one of four drive wheels. A dynamic test simulated the cable car accelerating to cable speed. The cable was motor driven as clutch pressure was increased. By measuring motor current the load transmitted from the cable to the grip was calculated. Another dynamic test simulated the stationary cable car with the cable running free through the grip. Cable speed and drive wheel speed were measured with a strobotach and compared to detect slippage.

CONCLUSIONS

Grip model tests show that the Helical Grip design is feasible. No sliding between the cable and drive wheel was detected during the dynamic tests, which indicates that cable and grip wear will be minimized. The static tests have demonstrated that the grip will provide enough force to pull the cable car. The clutch system worked properly, stopping the drive wheel against the cable.

Further development of the grip is planned. Long term wear tests on the model, investigations into guide roller and clutch interfaces and actuation on the full-scale grip are required. Eventually a full-scale grip will be tested on the cable car system in San Francisco.

REFERENCES

1. Giovannetti, A., "Study of San Francisco Municipal Railway Cable Car System", NASA-Ames Research Center, Moffett Field, CA, September 23, 1975.
2. Lepetich, James A., "Redesign of San Francisco Cable Car Gripping Mechanism", University of Santa Clara, CA, 1977.
3. Haahr, Mary Ellen, Peyran, Richard J., and Divine, Michel, "A Redesign of the San Francisco Cable Car Grip", Stanford University, CA, 1978.

(CALIFORNIA STREET CABLE CAR R.R. COMPANY)

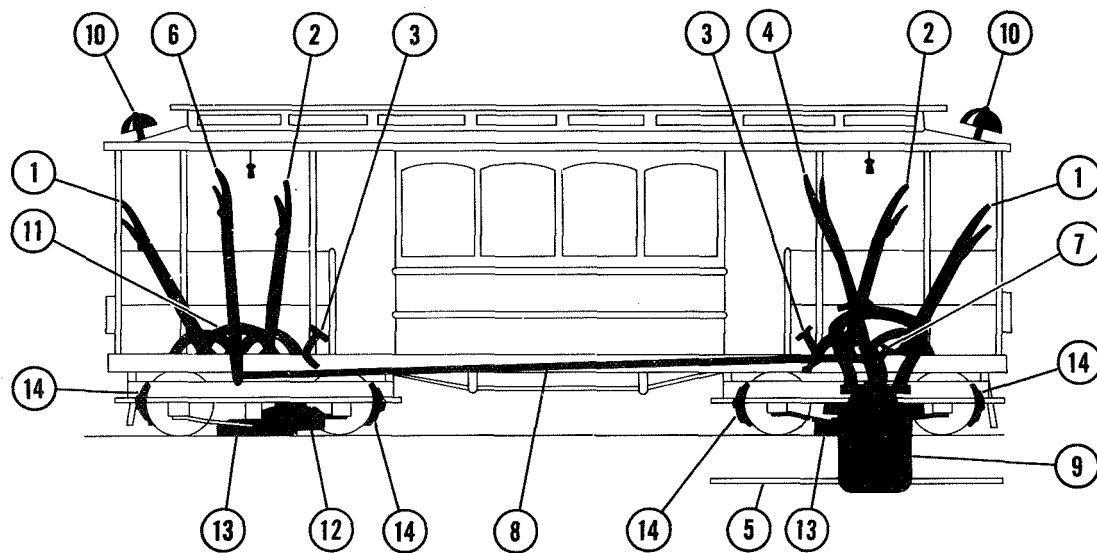

- | | |
|---------------------------|-----------------------------|
| 1. EMERGENCY BRAKE LEVER | 8. CONNECTING ROD |
| 2. TRACK BRAKE LEVER | 9. THE GRIP |
| 3. WHEEL BRAKE FOOT PEDAL | 10. BELL |
| 4. GRIP LEVER | 11. QUADRANT FOR GRIP LEVER |
| 5. CABLE | 12. EMERGENCY BRAKE |
| 6. GRIP LEVER (ALTERNATE) | 13. TRACK BRAKE |
| 7. ADJUSTING LEVER | 14. WHEEL BRAKE |

FIGURE 1. - SAN FRANCISCO CABLE CAR

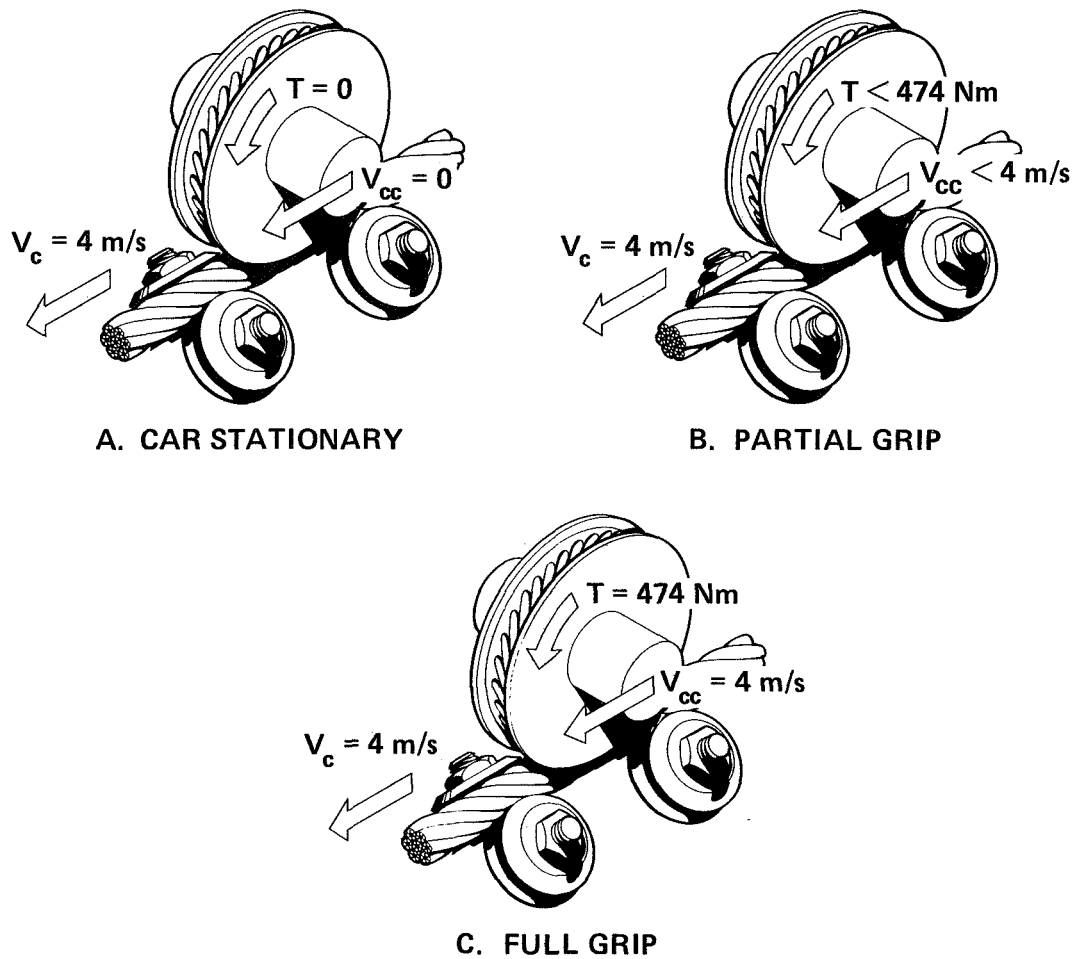

V_c = CABLE SPEED
 V_{cc} = CABLE CAR SPEED
 T = NET TORQUE ON DRIVE WHEEL
 FROM HYDRAULIC BRAKING

FIGURE 2. - DRIVE WHEEL-CABLE INTERACTION

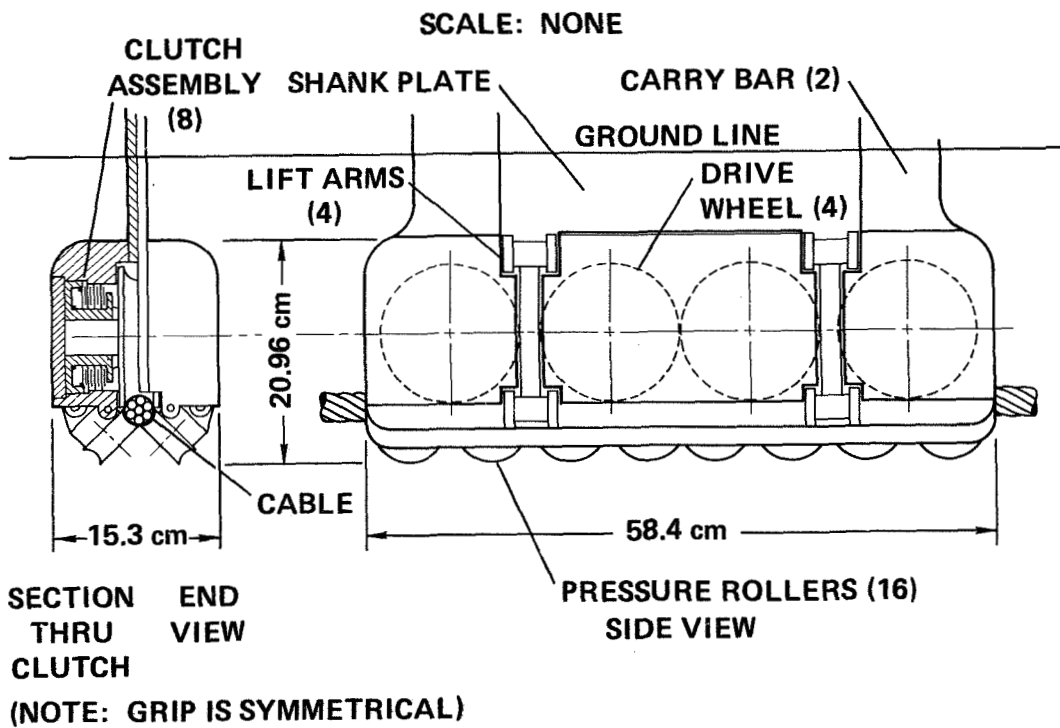

FIGURE 3. - COMPLETE HELICAL GRIP

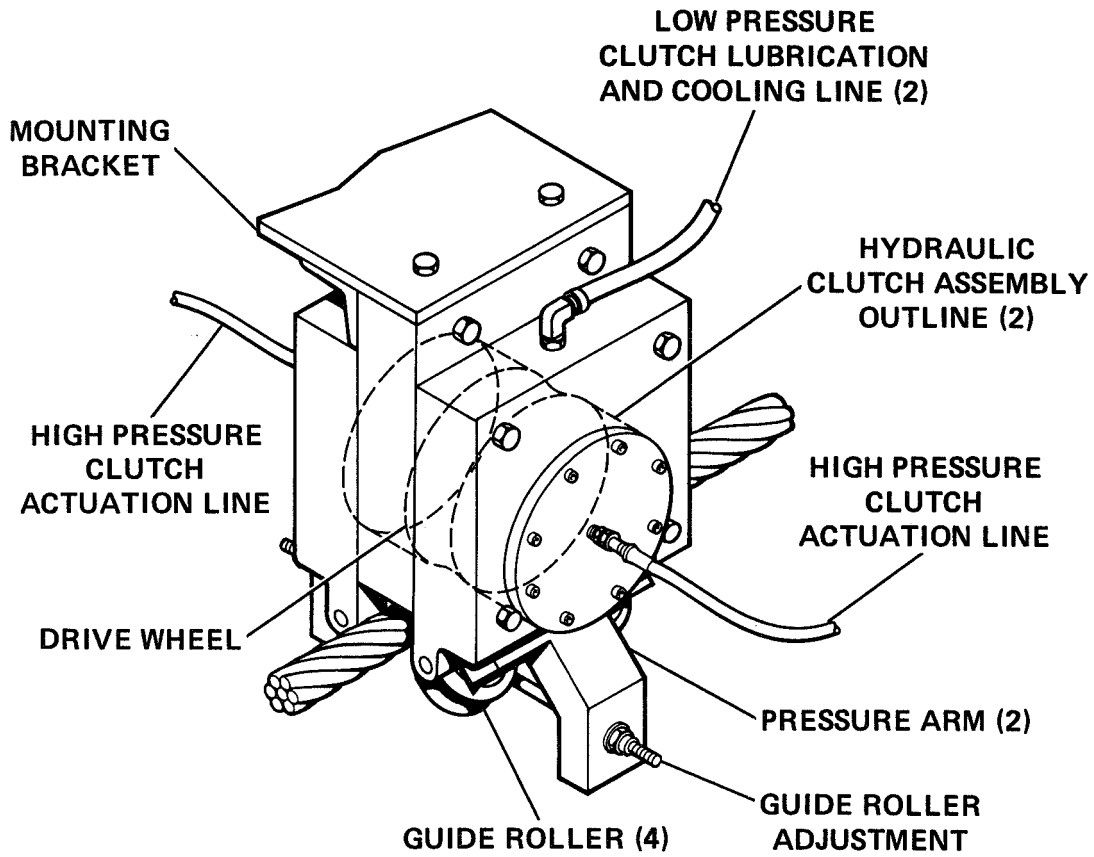

FIGURE 4. - GRIP TEST MODEL

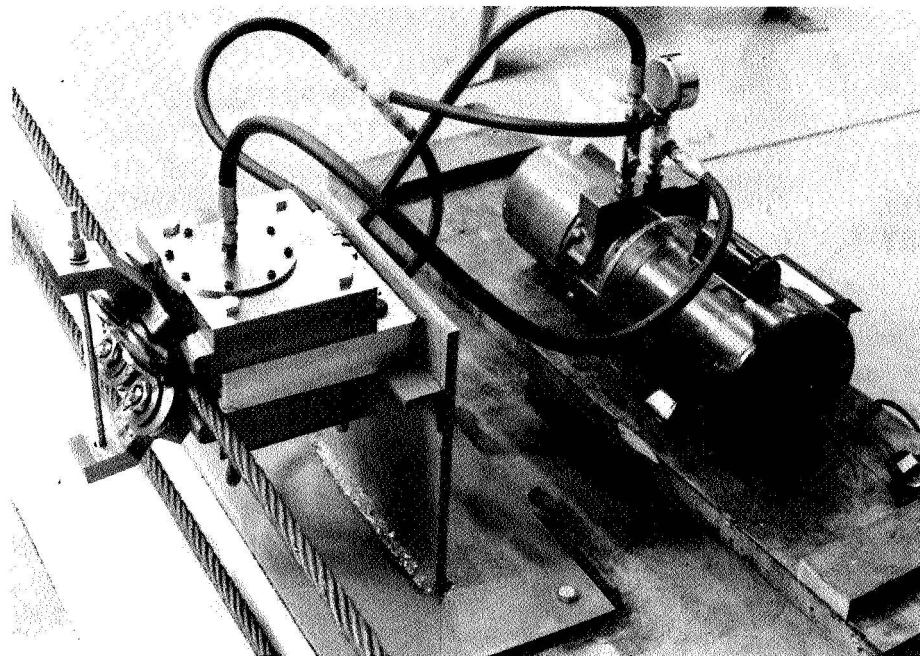

FIGURE 5. - TEST GRIP AND PUMP



FIGURE 6. - DRIVE WHEEL DETAIL

| ITEM | DESCRIPTION | ITEM | DESCRIPTION |
|------|-------------------|------|-------------------|
| 1 | 3 HP MOTOR | 9 | KLINE GRIP |
| 2 | JACK SHAFT ASSEM. | 10 | WINCH |
| 3 | AMMETER | 11 | FORCE GAGE |
| 4 | BELT TENSIONER | 12 | 10 in. DIA. BLOCK |
| 5 | CABLE LOOP | 13 | TURNBUCKLE |
| 6 | PRESSURE GAGE | 14 | CABLE PYLON |
| 7 | HYDRAULIC PUMP | 15 | GRIP PYLON |
| 8 | TEST GRIP | | |

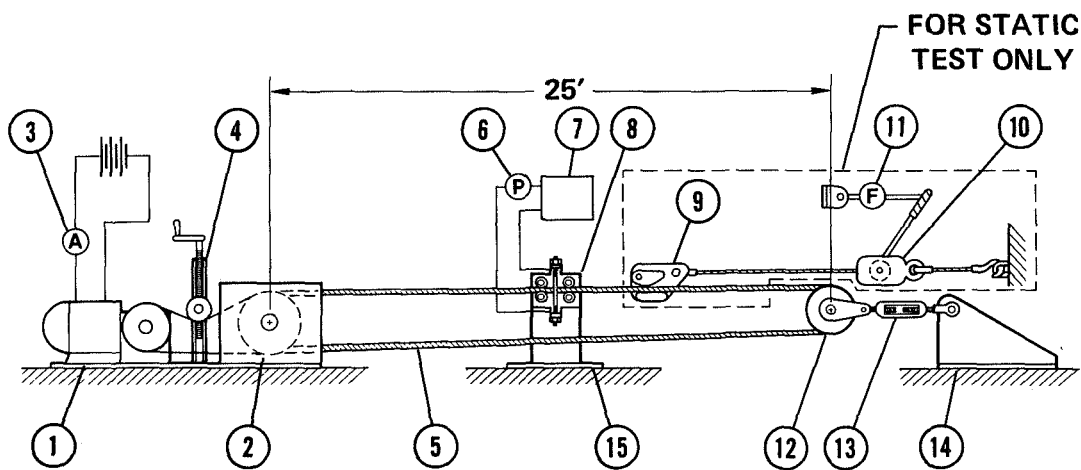

FIGURE 7. - TEST SET UP

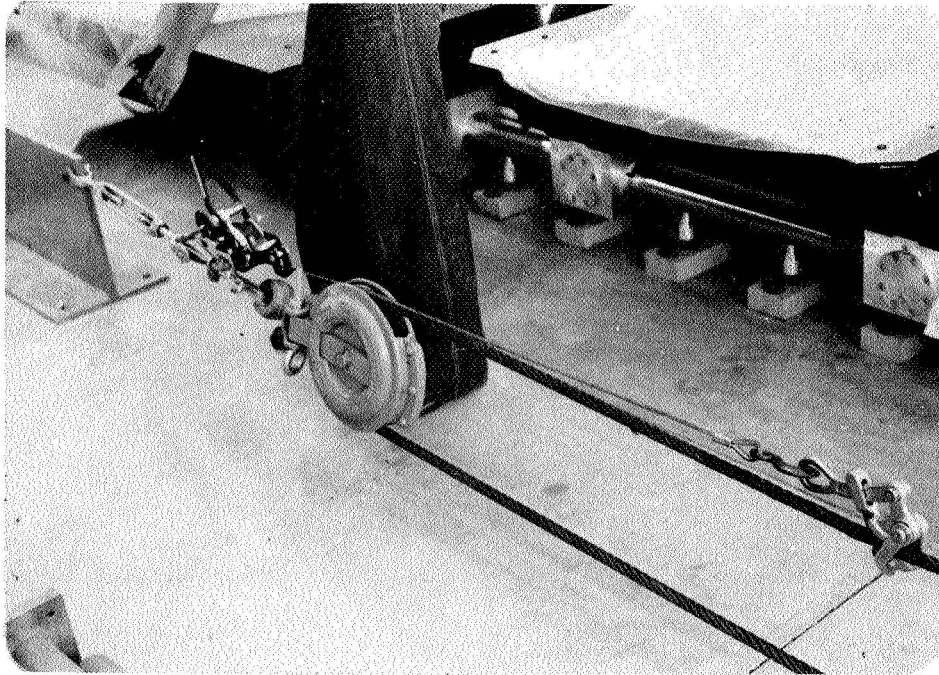

FIGURE 8. - STATIC TEST WITH MANUAL WINCH