

ON THE DESIGN OF AN ADJUSTABLE HIGH PRECISION LATCHING HINGE

John W. Ribble & William D. Wade
Lockheed Missiles and Space Company

Abstract

The design and test details of a high precision hinge and locking mechanism created principally in support of the Lockheed space deployable Flex-rib Parabolic Antenna concept are presented. These developed improvements in the detail design of ultra-precise rib hinge and contour adjustment mechanisms will allow radio frequency antenna reflectors to expand into the 15-50 meter diameter size class and to support the .013 mm. deployment repeatability tolerance required to support the 12+ GHz frequency range.

Introduction

In the spring of 1974 a 9.1 meter diameter Parabolic Antenna designed for use at frequencies up to 8 GHz was successfully placed in orbit. This reflector, shown in Figure 1 in its final deployed state, has operated satisfactorily ever since. The design is of the flexing wrap rib type, which consists of a number (variable) of radial ribs or beams which are cantilevered from a central hub structure. Each of the ribs is attached to this hub through a hinge. This radial spoke system provides the mounting for the antenna surface structure. Arrays are formed by mounting a membrane with elements on the front edge of the ribs and, if required, a ground plane on the rear edge. For parabolic or other curved reflectors, the ribs are formed in the required shape, and reflective pie-shaped gores are attached between the ribs. An overview of such a deployed system is presented in Figure 2.

The rib cross section and material are chosen to permit elastic buckling of the ribs. This is to allow the ribs to be wrapped around the hub structure in the ascent or stowed package configuration.

In the stowing process, the ribs and attached surface are rotated about the rib hinges until the ribs are tangent to the hub. After this rotation, the ribs are flattened and wrapped circumferentially around the hub. The elastic buckling of each rib accommodates this action. The surface material is allowed to form a package between the ribs. The elastic energy stored in the wrapped ribs is sufficient to accomplish deployment of the reflector. The stowed package is contained by a series of hinged doors which are held in place by a restraining cable. Deployment occurs when the cable is severed.

It was in the detail design of the rib hinge and latching mechanisms that need for design improvement was noted for larger, higher frequency designs. During the reflector assembly, excessive time was consumed in adjusting the rib tips to the required contour position tolerance of $\pm .965$ mm.

In addition, during testing larger-than-expected deviations from the "as adjusted" contour were experienced. While these items caused no significant performance degradations on that reflector, it was recognized that unless improvements were made, additional capability in either operational frequency or reflector diameter would be limited by these mechanism errors.

These concerns led to the initiation of a development study aimed at producing a mechanical reflector design showing improved setability and repeatability.

Symbols

η = efficiency
 π = pi = 3.141592654
 D = diameter
 λ = wavelength of the electromagnetic wave
 f = focal length of the antenna
 c = local speed of light
 G = gain
 δ = RMS distortion

Reflector Performance

The need for improved antenna surface tolerance control can be understood by a brief discussion of antenna performance. The gain of an antenna may be directly related to the physical properties of the antenna surface. Consider the case of a round aperture having a diameter D . In this instance, the antenna gain is directly related to the diameter by the simple expression

$$G = \eta_E \left(\frac{\pi D}{\lambda} \right)^2 \quad (1)$$

The above formula indicates that the gain of an antenna is directly proportional to the square of the diameter and the square of increasing frequency. The efficiency factor (η_E) accounts for the normally encountered degrading factors in any antenna system, including, among many other effects, resistive losses, reflection losses, aperture distribution losses, and blockage losses. Highly efficient systems have an efficiency of nearly 70 percent. Broad bandwidth systems have an efficiency of approximately 30 percent to 40 percent; moderate bandwidth systems of conventional performance generally have efficiencies in the 50 to 55 percent region. By specific exclusion, this efficiency factor does not include the impact of distortions.

For estimation purposes distortions of large structures can be considered as random errors in the surface. Exact treatment of the performance degradation caused by the actual distortions is a very complex issue, related to the type of antenna used, the distribution of errors, and many other factors. However, a reasonably well accepted and accurate relationship between gain in the ideal case and that achieved in the presence of small structural

distortions is represented by the relationship

$$G_d = G e^{-\left(\frac{4 \pi \delta}{\lambda}\right)^2} \quad (2)$$

where λ is the wavelength and δ is the RMS surface error. This can be re-written in terms of reflector efficiency as

$$G_d = \eta_\delta G \text{ where } \eta_\delta = e^{-\left(\frac{4 \pi \delta}{\lambda}\right)^2} ; \text{ mechanical efficiency (3)}$$

If we are dealing with statistically independent error sources, then δ is the RSS of the individual error sources. The overall efficiency equation can now be written as

$$\eta = \eta_E e^{-\frac{16 \pi^2}{\lambda^2} \left(\delta_S^2 + \delta_A^2 + \delta_T^2 \right)} \quad (4)$$

where δ_S is the surface error caused by manufacturing error and deployment non-repeatability, δ_A is the surface approximation error, and δ_T is the thermal distortion error.

The repeatability error term may now be investigated parametrically by plotting its efficiency against RMS distortion error divided by wavelength in order to normalize the results with respect to frequency. This result is shown in Figure 3. Based on previous experience in error allocation budgets for antenna systems, a reasonable efficiency contribution for repeatability is 95%. Thus it can be seen that in order to obtain a high overall reflector efficiency, the reflector mechanisms distortions must be kept small (i.e. $\leq 1/50$) compared to the wavelength of the radiated energy.

Mechanical Development

In response to the recognized need for reduced surface distortions and improved surface repeatability for evolving antenna needs, a development program was initiated in 1975 to isolate the sources of the errors encountered with the 9.1 meter diameter reflector and to reduce them with detail design improvements. As previously discussed, one error in the design was traced to the rib latch mechanism, shown pictorially in Figure 4.

The latch consisted of a taper-ended plunger situated parallel to the rib hinge line and preloaded by a 22 newton spring. The plunger rode against a quadrant located on the rib. When the rib reached the fully-deployed position, the plunger would travel beyond the end of the quadrant and snap into the latched position. A loading diagram of the hinge portion of this latch mechanism is shown in Figure 5. This latch orientation induced torque moments T about the long axis of the rib which caused it to deflect from the desired contour position. In addition, this torque varied according to the

exact final position of the plunger each time the rib was deployed, giving rise to variations in the rib position each time it was operated.

A second area of concern in the reflector was the method used to adjust the rib positions to establish the required contour. Three rib hinge adjustments were required to be made simultaneously. The rib was adjusted vertically at the hub, rotated with respect to the hinge axis in order to provide vertical adjustment at the tip, and the fully deployed position was adjusted to insure that the rib extended in an exactly radial direction. The radial position stop was a screw adjustable stop, which operated quite satisfactorily. The other adjustments, however, in practice required the expenditure of large amounts of time to achieve the required accuracy. The hub end of the rib was adjusted vertically by exchanging matched pairs of graduated shims. While the shims functioned well, changing and checking these matched pairs was extremely time consuming. The angular adjustment at the hinge required to achieve vertical adjustment at the rib tip was accomplished by tapping a sliding block housing for the hinge bearing with a suitable hammer. This proved to be a trying process. Therefore, design efforts in the development program were directed at eliminating these causes for concern.

Design requirements for a new reflector were based on typical known large reflector needs. An attempt was made where economics allowed, to better these requirements, recognizing future needs to extend both the size and operating frequency of parabolic antennas. Table I lists the assumed requirements for the study. The hinge design which evolved is shown in Figure 6. In that design the plunger was relocated to the rib and positioned to move in a direction perpendicular to the hinge line halfway between the hinge bearings. Thus, no torque is transmitted to the rib from variations in latch loads, eliminating one source of contour non-repeatability.

The elimination of induced torque due to latching loads also allowed the latch mechanism to be utilized to eliminate bearing freeplay. The use of a rib hinge always creates hinge bearing clearance problems which manifest themselves as contour inaccuracies. In the case of the new design the bearing freeplay magnification ratio (i.e., length of rib/bearing separation) is 50:1. Therefore in order to produce a reflector contour which is repeatable, the bearing freeplay was eliminated at the completion of deployment by utilizing a very high force spring to drive the latching plunger. A further complication is the one-g environment under which the contour must be set and measured. The latch spring was also designed to drive the rib bearings to a repeatable position whether the reflector is deployed with the concave side up or down, thus eliminating the one-g deadband in the bearings.

The other major change incorporated into the new design is the method of achieving vertical adjustments at the rib root and tip. The resulting vernier rib adjustment mechanism which was developed is shown in Figure 7. The design goals which led to this adjustment device were:

- (1) Adjustment Fineness - The ability of the mechanic to "feel" $\pm .25$ mm tip motion.

- (2) Repeatability - Once the adjustment was made, it could be expected to remain in that position.
- (3) Readjustability - If for some reason it was found necessary to change the setting, disassembly would not be required.

The bottom (side away from contoured side of rib) hinge bearing is held by a housing which is adjusted radially by a differential screw device. Turning the adjusting collar 180° results in a .25MM vertical rib motion at the rib root vertical adjustments can be made by changing one shim, thus eliminating the need for matched shim pairs.

Design Verification

The hinge model shown in Figure 6 was subjected to repeatability tests during the spring of 1978. Results of those tests are summarized in Table II. Initial tests showed excessive deflections in the hinge. The difficulty was traced to deflection in the lower hinge pin (see Figure 8). The deflection in this pin caused by the latching loads from the plunger spring were in the order of 0.2 mm, which could result in a mechanical efficiency contribution in the projected design of 36%. The pin was therefore redesigned and stiffened as shown in Figure 8. The new pin was installed and the results of Table II obtained, resulting in a projected mechanical efficiency contribution of 98% for the design which was well above the 95% goal.

The results of these tests enabled a go-ahead to manufacture and assemble a 4-rib, 3-gore section of a complete 15 meter diameter reflector. This model (Figure 9) has been completed and is currently scheduled to undergo engineering development testing to verify deployment dynamics and contour repeatability.

Conclusions

The design of a latching hinge capable of supporting antenna reflectors in the 15-50 meter diameter range and 12+ GHz frequency range has been achieved. This hinge design achieves deployment repeatability of within $\pm .010$ mm across the bearings and allows positive vertical rib adjustments of $\pm .05$ mm at the root and .25 mm at the tip.

TABLE I

Requirement	Value	Compliance
Diameter Deployed	15 M	15.24 M
Diameter Stowed	<200 M	1.90 M
Reflector Weight	<138 Kg	122 Kg
Operating Frequency	9 GHz	8.5 GHz
Surface Approx Loss	<.5 dB	.5 dB
Thermal Dist. Loss	.1 dB	.045 dB
Torque Transmitted to S/C	<46.6 Newton-M	34 Newton-M
Launch Environment	+ 20 G's*	.08 M.S.
f/D Ratio	.44	.44
Mfg. & Repeatability/Loss	<.07 dB	.02 dB

* Applied in 3 orthogonal directions simultaneously - equivalent static inertial load

TABLE II

Load Condition	Deflection at 1g load	Deflection After Load Removal
Vertical Shear	.015	.010
Horizontal Shear (Toward Deployment Stop)	.012	.008
Horizontal Shear (Away from Deployment Stop)	.011	.0075

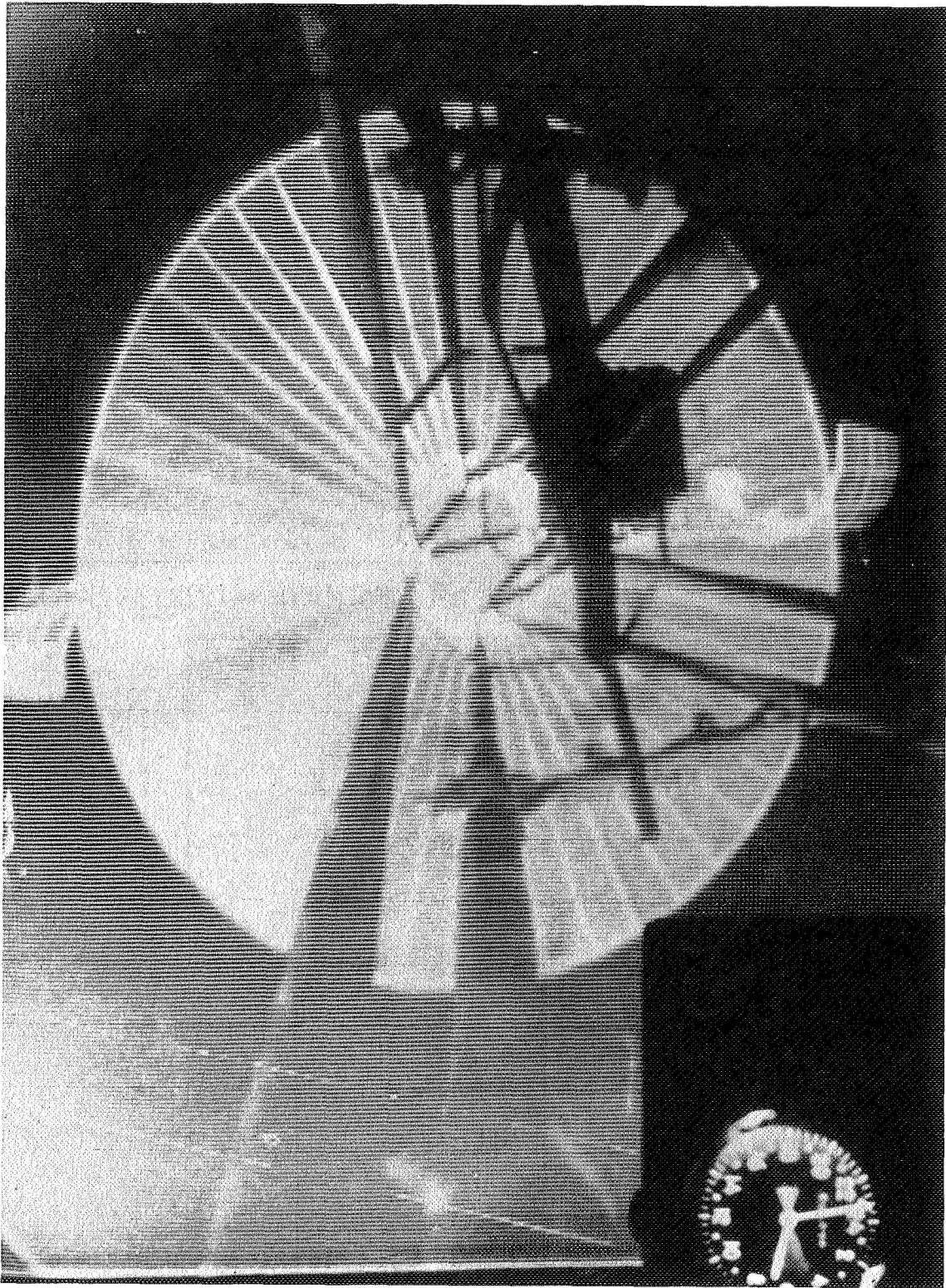

FIGURE 1
10 METER DIAMETER REFLECTOR DEPLOYED IN ORBIT

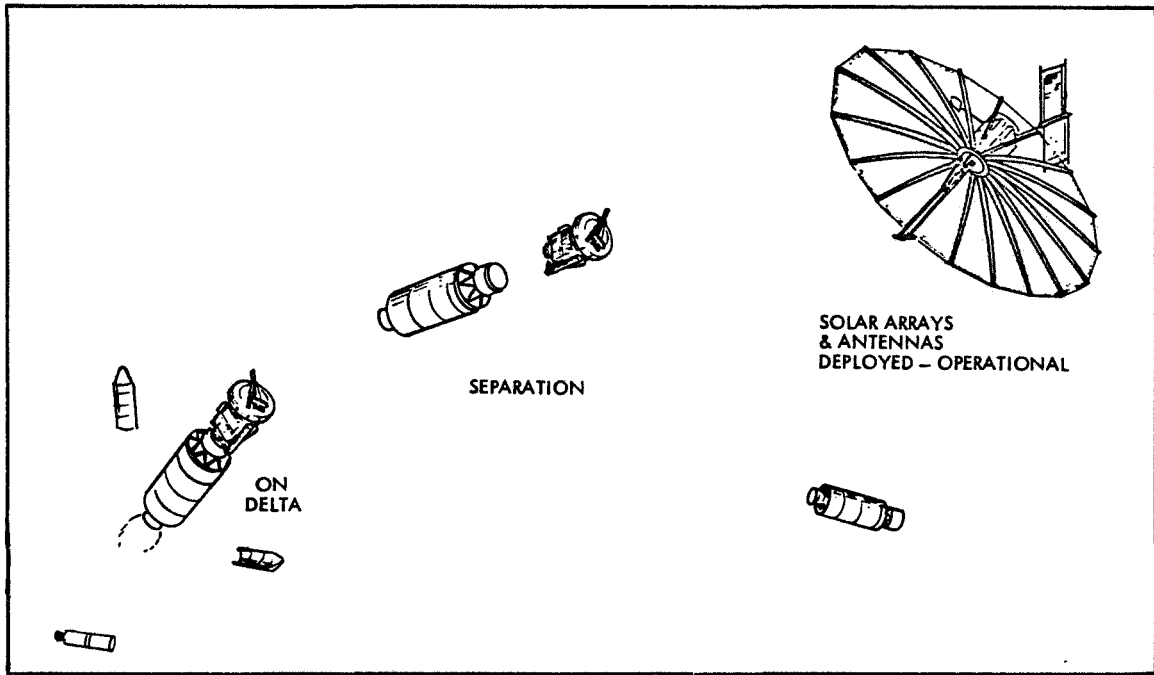

FIGURE 2 MISSION PROFILE-SATELLITE DELIVERY (OPTIONAL DELTA LAUNCH)

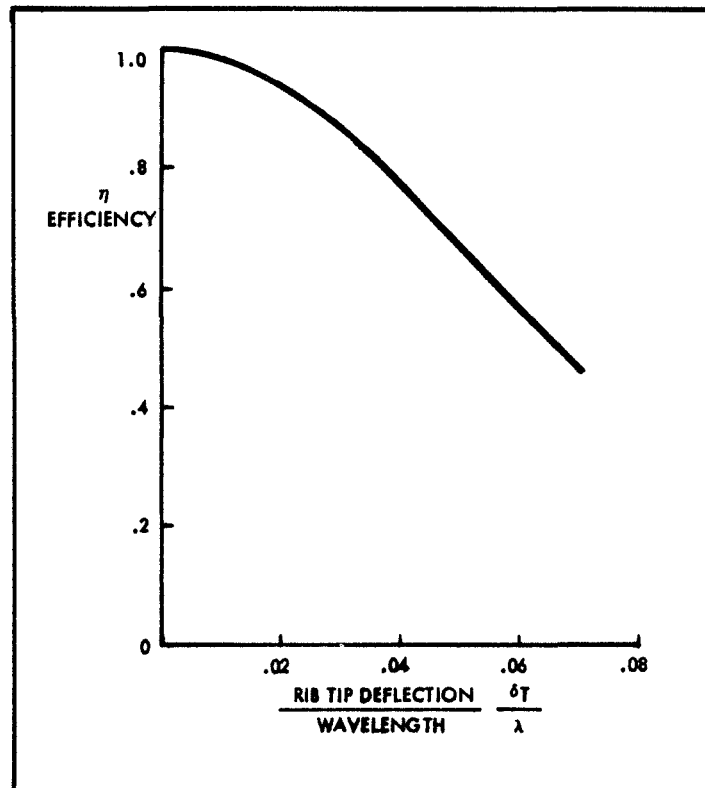

FIGURE 3 REFLECTOR EFFICIENCY EFFECT OF SURFACE DISTORTION

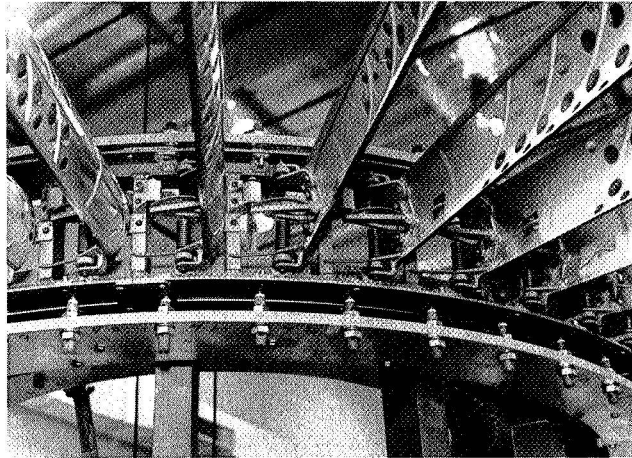

FIGURE 4
RIB HINGE & LATCH ASSEMBLY FOR 9.1 METER DIAMETER REFLECTOR

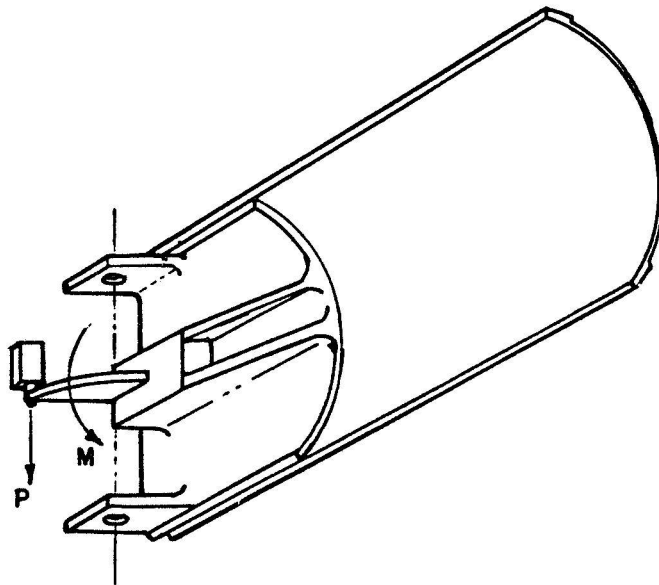

FIGURE 5 HINGE LOADING DIAGRAM

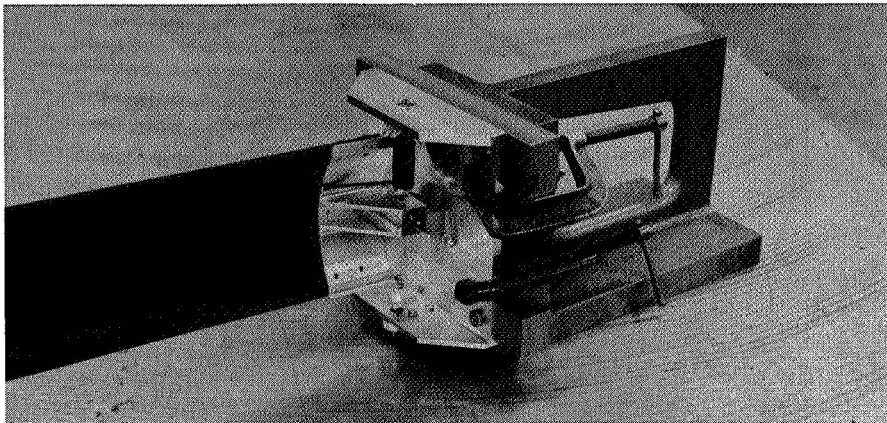

FIGURE 6
REDESIGNED RIB HINGE & LATCH ASSEMBLY FOR 15 METER DIAMETER REFLECTOR

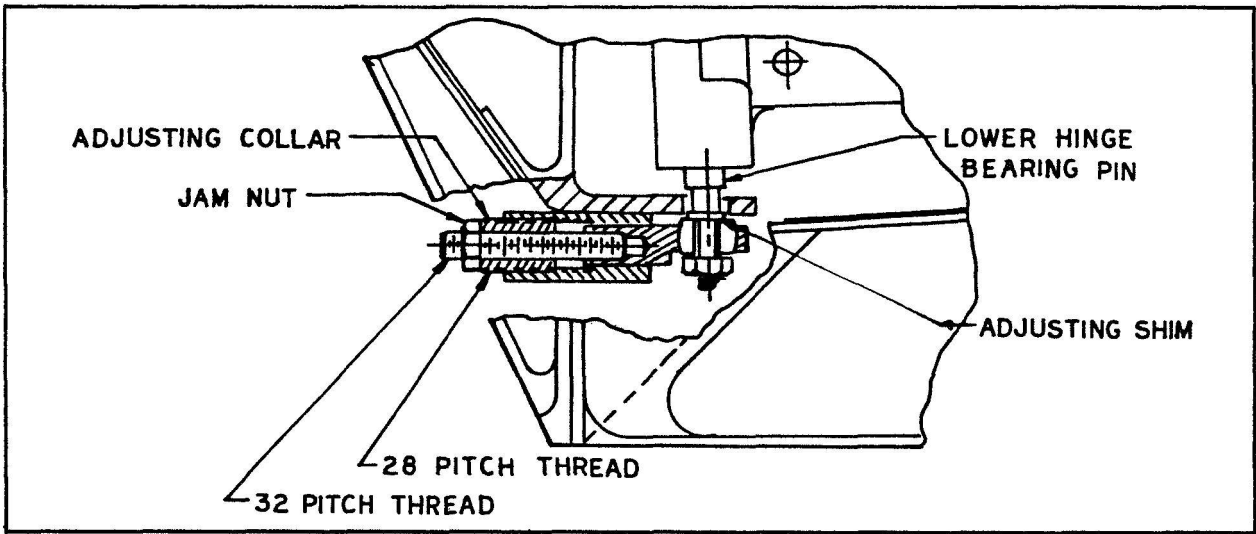

FIGURE 7

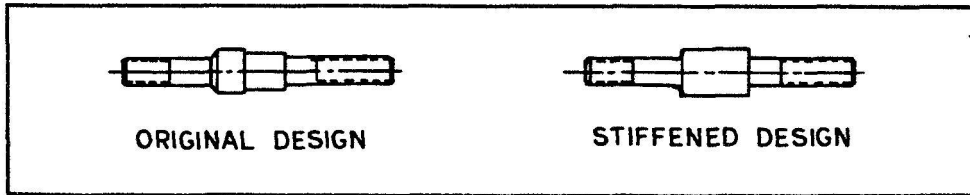

FIGURE 8

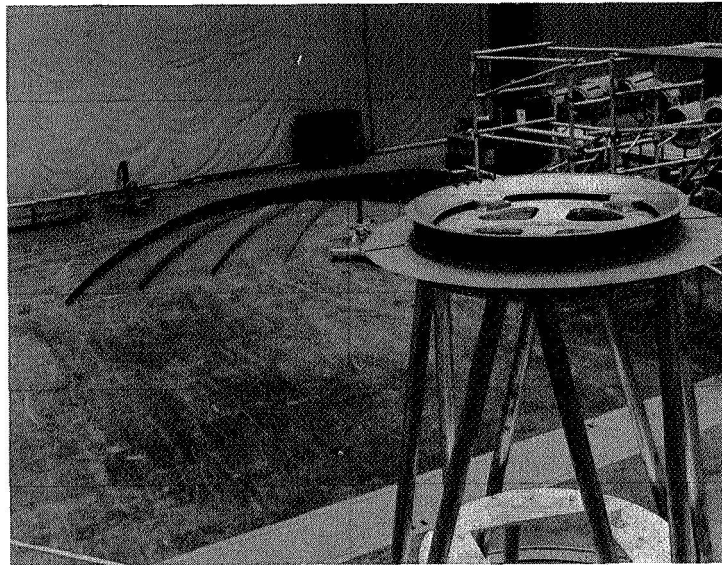

FIGURE 9