

DEVELOPMENT OF DRIVE MECHANISMS FOR COMMUNICATION SATELLITES

by Arnold C. Schneider and Thomas D. McLay

General Electric Space Division
Valley Forge, Pennsylvania

ABSTRACT

A distinguished pedigree is an important asset in the development of Aerospace mechanisms. Four drives recently developed for communication satellites are outgrowths of a previously-proven drive configuration.

Pedigree by itself, however is not enough to generate success. Inevitably, design changes which are thought to be minor, are generally introduced to fine tune the pedigreed hardware to meet particular requirements of a specific new application. Such design changes are often viewed too casually and are not thoroughly tested in the early development stages of the program. This paper describes two areas of design change on the solar array drive applied to the Japanese Broadcast Satellite (BSE) which led to subsequent problems during the development phase of the program. The methods applied to establish the cause and the solution of these problems are described as well as the testing approach adapted to prevent similar occurrences on the current Communication Satellite Program, The Defense System Communications Satellite III (DSCS III).

INTRODUCTION

Today the solar array drive for the Japanese Broadcast Satellite (BSE) is performing perfectly in orbit. Likewise, the solar array drive and the gimbal antenna drives for the Defense Systems Communications Satellite III (DSCS III) have successfully passed their qualification tests. One of the primary reasons for the success of these drive mechanisms has been their common pedigree.

During 1971, GE developed a drive concept using company discretionary funds. This design concept was a fully redundant drive system utilizing two drive modules, each one consisting of a D.C. stepper motor, a harmonic drive speed reducer, spur gear speed reducer, and a wrap spring clutch. (Reported at the 8th Aerospace Mechanisms Conference in October, 1973).

The BSE solar array drive is a flight version of this original design concept with some minor changes in order to reduce weight. The DSCS III solar array drive is a modified version of the BSE drive providing a more compact assembly and a further reduction in weight.

The DSCS III gimbal dish antenna actuators use the basic parts from the drive system developed in 1971, including some simplifications that are possible because their reliability requirement can be met without redundancy.

DESIGN DESCRIPTION

BSE Solar Array Drive

The BSE solar array drive consists of two completely redundant unidirectional drive modules that are interconnected by two, passive, wrap spring clutches (see Figure 1). These clutches permit either drive to be energized with a resultant output torque of 18 Nm (160 Lb.In.) or both to be energized with a torque of 36 Nm (320 Lb.In.). Each drive contains a 1.8 degree step angle, stepper motor, a 100:1 harmonic drive speed reducer, and a 6.05:1 spur gear set. Power is transferred from the rotating solar array panels to the vehicle structure by means of a slip ring assembly consisting of 20 signal rings and four power rings. The slip ring assembly is mounted around the one-piece output shaft that connects the two redundant drives.

DSCS III Solar Array Drive

The DSCS III solar array drive is a modified version of the BSE drive (see Figure 2). The concept of redundant drive modules is maintained, but the output of the drive modules is a common bull gear rather than the output shaft. The assembly includes two slip ring modules which are integrated into the support housings to reduce weight and to eliminate extra bearings. A separate torque tube connects the driving half of the assembly to the non-driving half.

DSCS III Antenna Actuators

The DSCS III antenna actuators (see Figures 3 and 4) are exact replicas of the BSE drives from stepper motor to pinion gear. The spur gear has been changed to a segment, and the gear ratio has been reduced to minimize weight. A conductive film potentiometer and stops have been added (see Figure 5) to meet design requirements, and the wrap spring clutch has been deleted since the need for redundancy has been eliminated.

BSE Reed Switches

Reed switches are used in the BSE solar array drive to generate position inputs to the Attitude Control Subsystem for roll and yaw axis control. Two switches are mounted side by side in each of four position indicator switch assemblies. These assemblies are mounted at 90° spacing around the solar array drive shaft to indicate quadrant position. A bar magnet, which is installed into the position indicator switch assembly, normally keeps the contacts of the two reed switches closed. A disc with a 90° gap is attached to the solar array drive shaft and passes between the magnet and the switches (see Figures 6 and 7). When the 90° sector of the disc passes an assembly, the switches remain closed; but when the solid 270° sector passes an assembly, the magnetic field is interrupted and the switches open. Since the shaft normally rotates at an average speed of one revolution per day, each pair of switches is normally open for six hours per day and closed for 18 hours per day.

BSE Reed Switch Problem

The Reed Switches were purchased from a contractor to a detailed Switch specification. This detailed Switch specification was prepared using test methods for Reed Switches in accordance with MIL-S-55433. These switches worked well during acceptance testing, but during qualification testing of the entire solar array drive assembly, the following facts and theories became apparent.

Facts

1. Switches that operated successfully through extensive ambient and thermal cycling sometimes remained closed after vibration.
2. These switches eventually opened after:
 - a) disturbance of magnetic field
 - b) physical disturbance

Theories

1. Despite the presence of the disc, the magnetic field at the switch is significantly high.
2. Vibration causes switch blades, which closed, to stick. (It is a well known fact that switches do stick after subjection to vibration while closed. This phenomenon is listed as a theory since all our switches were tested for sticking per MIL-S-55433).

To prove the validity of these theories, we had to assume that switch design problems could exist that would not show up until sub-system installation. For example, all the switches had been tested for sticking per MIL-S-55433. Therefore, Theory No. 2 could only be valid if the subsystem installation environmental conditions caused greater stress than imposed by the specified piece part test:

In order to investigate Theory 1 above, a test was devised to plot magnetic field at the switch locations versus disc position (see Figures 8 and 9). With switches of differing known pull-in and drop-out values installed in the test fixture, the disc was moved in and out until both inner and outer switches actuated. A number of conclusions were evident from this testing:

1. With the disc in the switch open position, the magnetic field at the switches is considerable (16 ampere turns vs. 20 ampere turns drop-out).
2. The field strength at the outer switch is always higher than at the inner switch (due to magnetic leakage around the disc).

In order to investigate Theory 2, a test fixture was fabricated to allow vibration testing of the switches and disc disassembled from the complete assembly. During this testing, one of the switches remained closed despite: 1) replacement of the disc with a demagnetized disc, 2) reduction of the disc gap to zero (reduced magnetic field), and 3) replacement of the magnet with a weaker magnet. It opened when it was lightly tapped. The switch was revibrated and stuck again. This time the switch was left alone and opened by itself after approximately six hours. The vibration was then separated into bands by frequency with the following results:

<u>Frequency</u>	<u>g level</u>	<u>Results</u>
80 - 160 Hz	24	No Sticking
160 - 230 Hz	36	No Sticking
230 - 1100 Hz	26	Stuck
1100 - 1400 Hz	60	Stuck
1400 - 2000 Hz	13	No Sticking

An accelerometer mounted to the switch assembly indicated a resonance at around 900 Hz with an amplification of about 4.5X. It was felt that an increase in the natural frequency which would remove the resonance might prevent sticking. In order to test this theory, an .090" aluminum stiffener was bonded to the switch assembly. The switch did not stick after vibration. The stiffener was removed and again the switch stuck after vibration. The conclusion reached was that the switch sticks when the g level exceeds about 36 g's.

Discussions were held with the switch vendor regarding our failures. The vendor felt that the switch being used was "too small" for a critical application and that the next larger switch would perform better for the following reasons:

1. A heavier coating of rhodium
2. More snap action
3. Made on automatic equipment (i.e., better quality control)

The larger switches were purchased and fabricated into six (6) assemblies using identical procedures and materials. These switches were vibrated at the highest levels with gap settings equivalent to only two ampere turns margin without failure.

The following changes were implemented to eliminate the problem:

1. Changed switches to larger type.
2. Changed switch specification to tighten pull-in and drop-out ranges and to reject switches that stick by 1 ampere turn or more.
3. Redesigned bracket for higher stiffness.
4. Added a field strength requirement to the magnet drawing to control all magnets.
5. Tested all switch assemblies as follows:
 - a) must pull-in with .40 oersted magnet
 - b) must drop-out with .92 oersted magnet
 - c) disc position @ drop-out must exceed vehicle setting by 1.5mm
 - d) vibration test

BSE Wrap Spring Problem

Wrap springs are used in the BSE solar array drive to transmit torque from the two redundant drive modules to the common output shaft (see Figure 10). In transmitting this torque, each spring must bridge a gap between the driving hub and the driven shaft. Accurate control of this gap is necessary to prevent the spring from wedging itself into the gap.

Two significant changes were made between the original testing of the wrap springs and the flight configuration. In the original testing, a single spring drove the output shaft; whereas, in the flight configuration, two widely separated springs (56 cm between springs) were utilized. In addition, the flight springs had drastically reduced cross section in order to minimize weight. As a result of these two changes, the spring exhibited a tendency to wedge itself into the gap under extreme loading (20 to 30 times the anticipated torque). Analysis of the anomaly revealed the following facts:

1. Bearing axial play, shimming, thermal effects, and gap setting tolerances were producing a 0.84 mm gap.
2. Under extreme loading, the spring forces at the gap deflect the structure thereby causing the gap to open as much as 0.46 mm on one side.
3. The corner radii (or chamfers) on the spring cross section cause a wedging action on the shaft that permits the gap to increase as much as 0.38 mm due to structural flexibility.

Previous analysis of Item 1 had shown ample margin (.84 mm gap vs. a 1.47 mm cross sectional width of the lighter spring). It was determined during tests of the complete assembly that Items 2 and 3 in combination with Item 1 resulted in a gap that would exceed the spring width (.84 + .46 + .38 = 1.68 mm which is greater than 1.47 mm). Thus, the gap width should be sized by dynamic as well as static analysis. The dynamic effects may only be measured by performing tests on the component.

By accurately controlling the shimming of the bearings and the setting of the gaps, we are able to reduce the contribution of Item 1 to 0.45 mm. With these changes, the spring ceased to wedge into the gap. Under even the most severe loading and worst tolerances, the gap is 0.18 mm less than the spring cross sectional width.

DSCS III Approach to Testing

The approach to testing on the DSCS III program has been to perform as much in-process testing as possible in order to uncover potential problems as early as possible. A list of the significant tests performed on the DSCS III solar array drive and antenna drives is as follows:

1. Complete functional and environmental testing of an engineering model.
2. 100% run-in of bearings and gears for prime usage.
3. Precise monitoring of wrap spring gap.
4. Measurement of motor and harmonic drive friction torque at temperature extremes.

An engineering model of the solar array drive was fabricated including all of the critical piece parts (see Figure 11). The assembly was subjected to the full DSCS III qualification test levels for vibration and temperature. At the conclusion of these environmental tests, the assembly was completely disassembled and inspected for damage and/or wear. The inspection did not reveal any out of tolerance conditions.

All bearings and gears, including the harmonic drive, were run-in, inspected, and thoroughly cleaned before being installed into prime assemblies. This run-in assures a smooth running assembly with no possibility for high friction due to burrs, chips, or surface imperfections.

In the modified solar array drive configuration of DSCS III, the critical wrap spring gap is not capable of direct measurement. In order to prevent a repeat of the BSE wrap spring problem, the piece part tolerances were held extremely tight and the mating pieces were measured prior to assembly. As a result of these controls, the gap was held to 0.25 ± 0.10 mm which eliminated the possibility of a problem.

The most important pre-assembly test on DSCS III was a measurement of stepper motor and harmonic drive friction torque in a prime configuration at temperature extremes. This measurement yields a direct indication of the excess stepper motor torque, over and above internal friction, that is available to overcome external loads and inertia. This in-process test revealed a low temperature problem associated with the harmonic drive and a high temperature problem associated with the stepper motor. Both of these problems were readily identified and corrected. However, if this testing had not been performed, we would have experienced these problems for the first time at the assembly level. Since the problems occurred at both high and low temperature, it would have been extremely difficult to identify the two separate sources, motor and harmonic drive, at this level of assembly.

CONCLUSIONS

A proven pedigree plus early testing of all modifications insure a successful design. A successful design plus ample in-process testing produces quality hardware. These principles have been successfully applied in the development of four drive mechanisms for the BSE and DSCS III communication satellites.

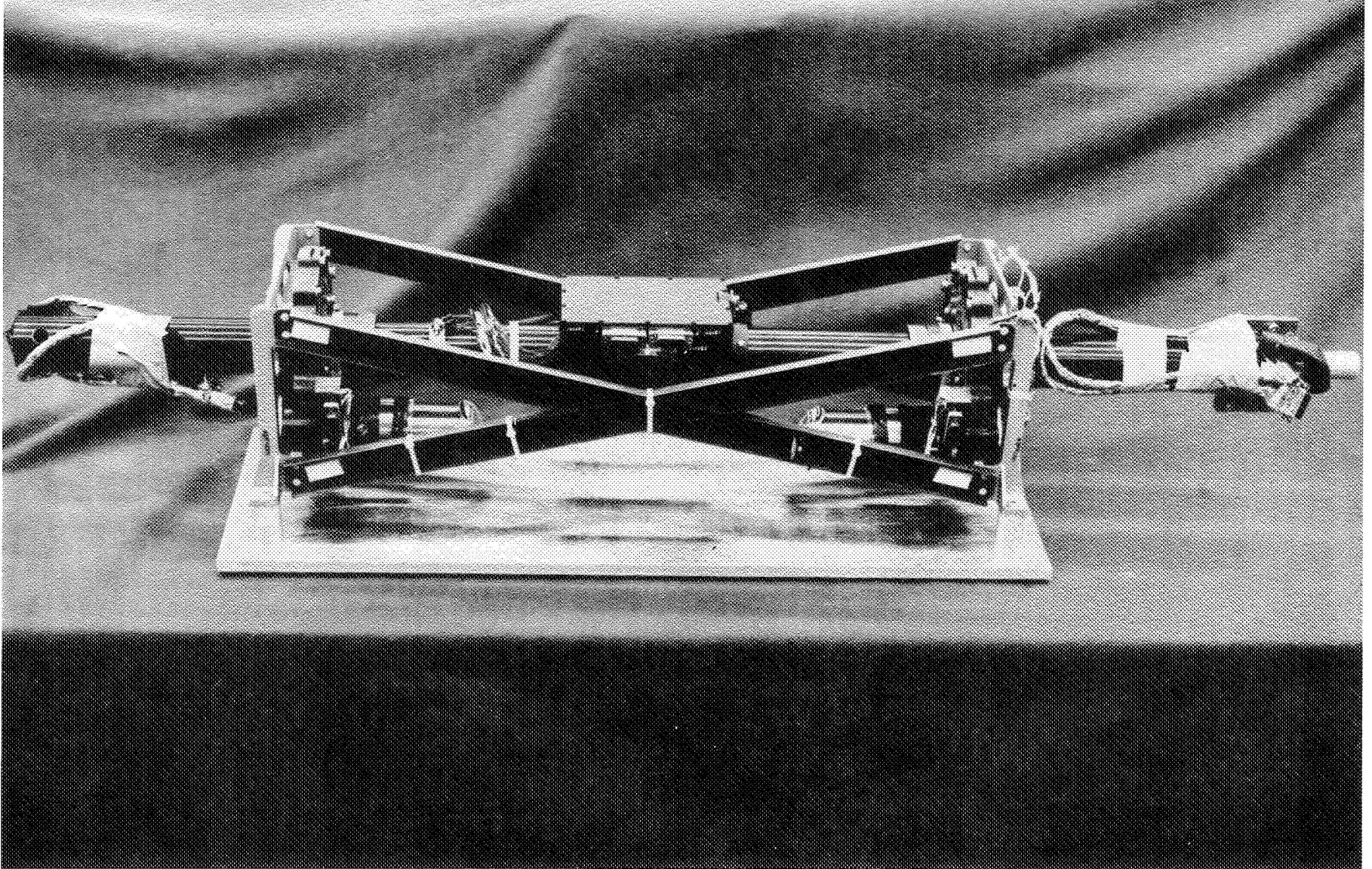

Figure 1. BSE Solar Array Drive

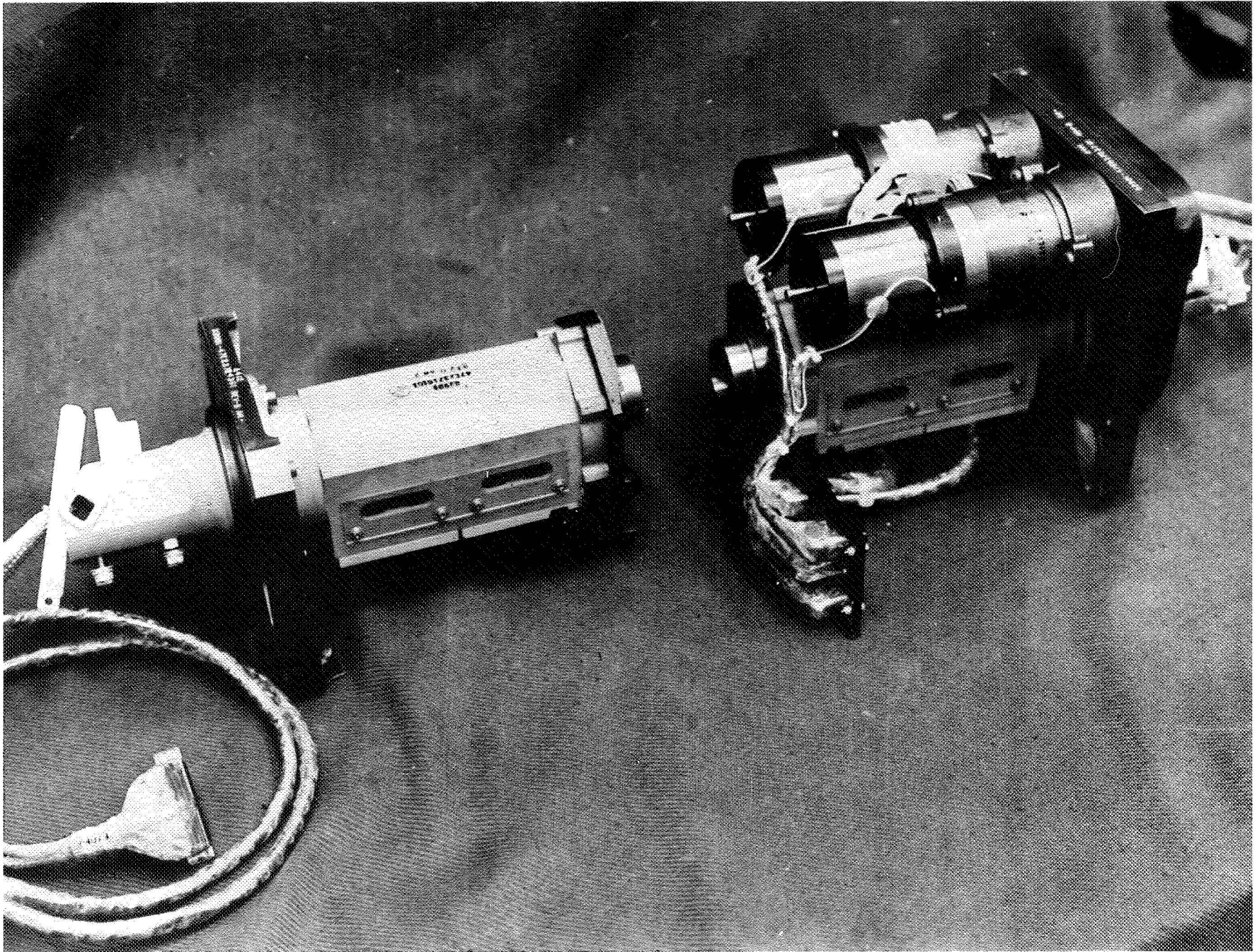

Figure 2. DSCS III Solar Array Drive (Torque Tube not Shown)

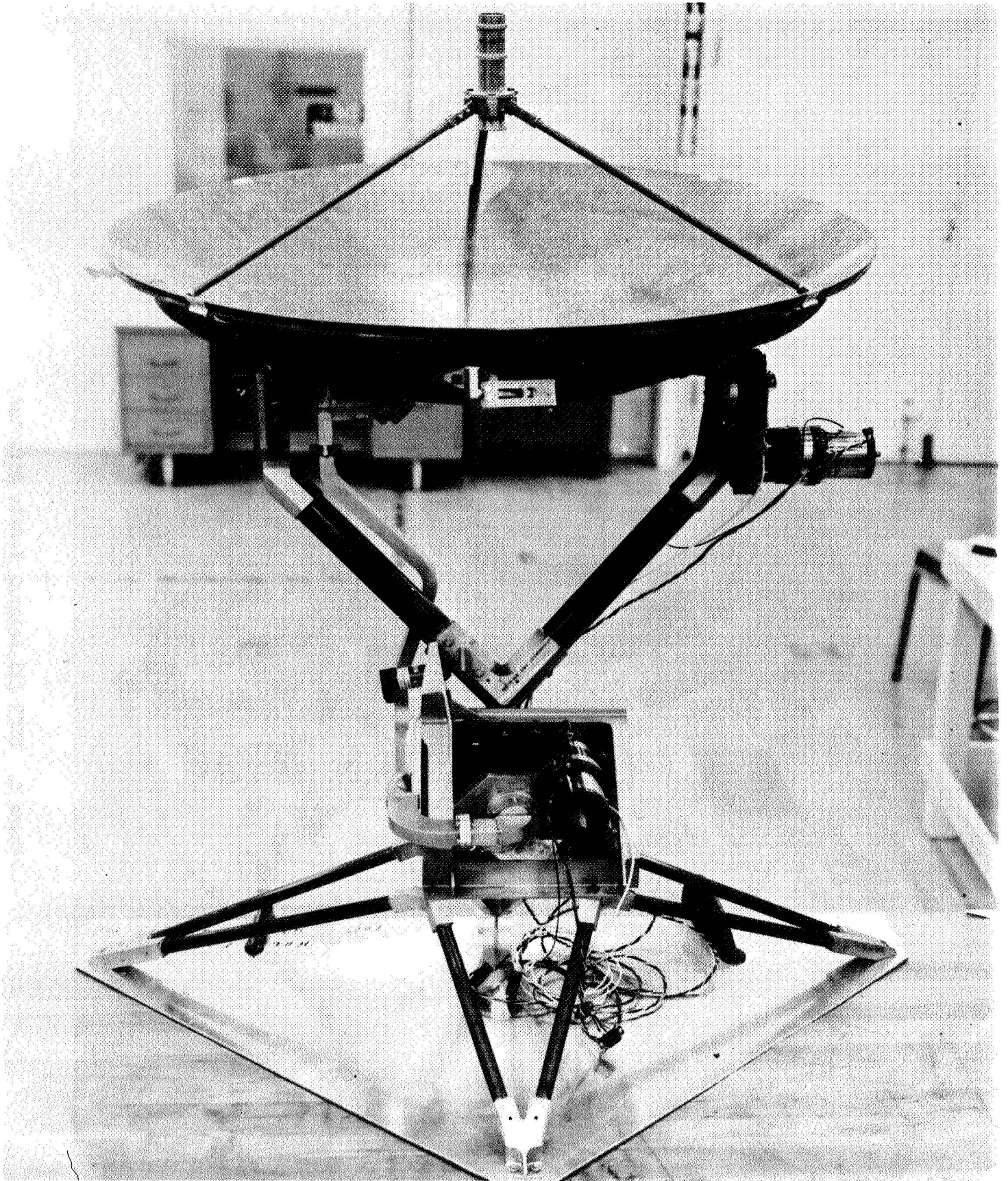

Figure 3. DSCS III Gimballed Antenna

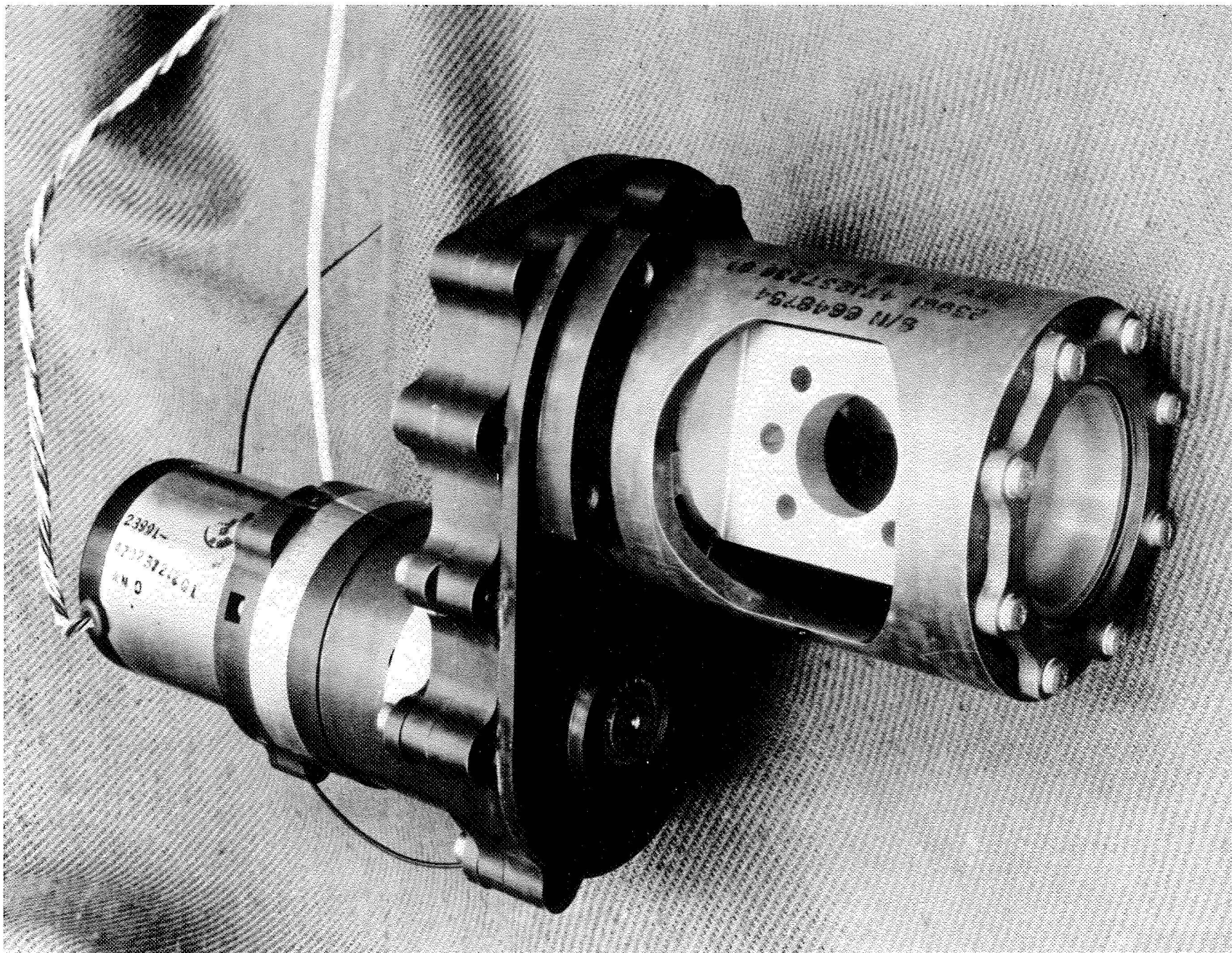

Figure 4. DSCS III Antenna X-Axis Actuator

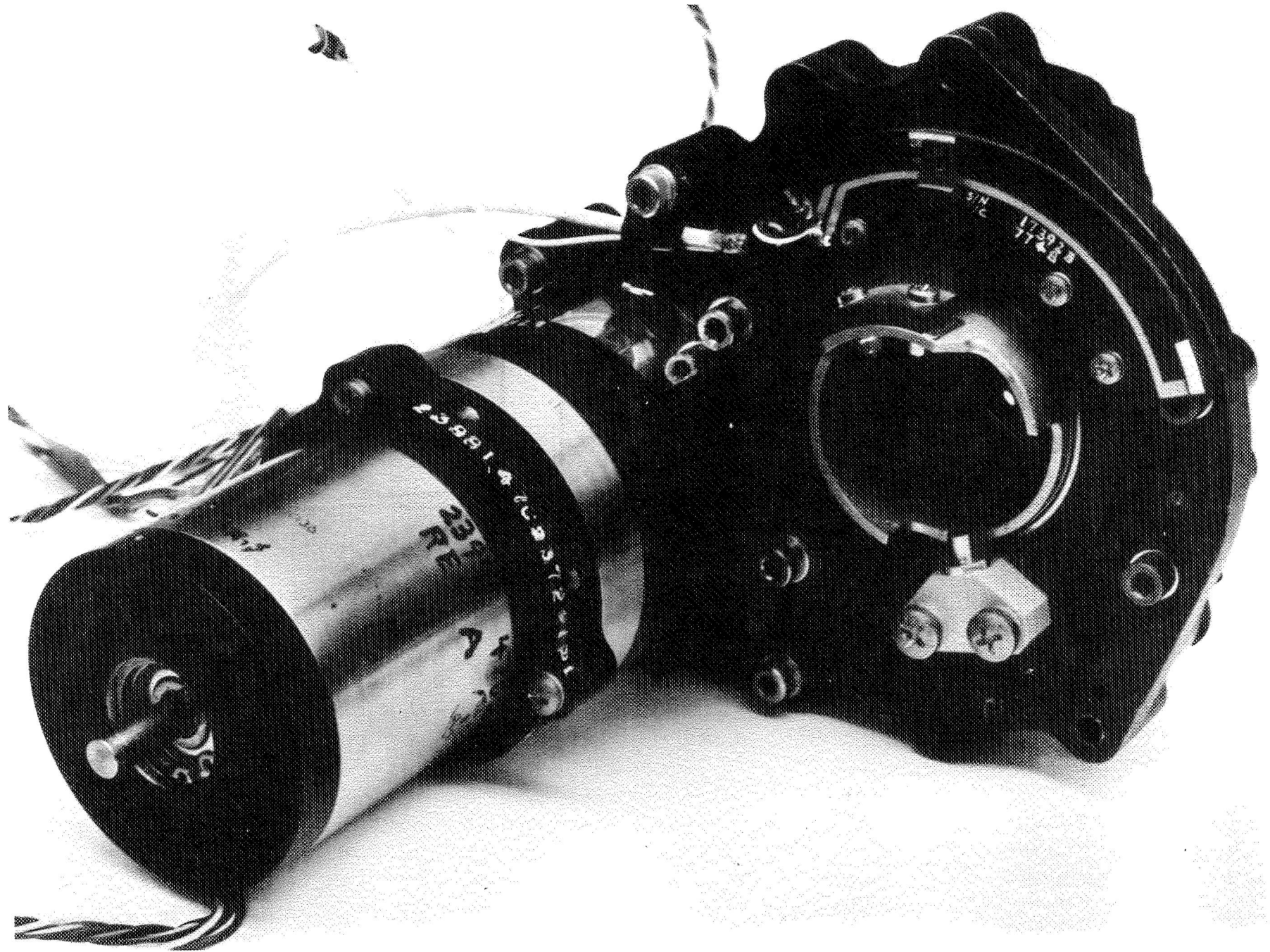

Figure 5. DSCS III Antenna Y-Axis Actuator

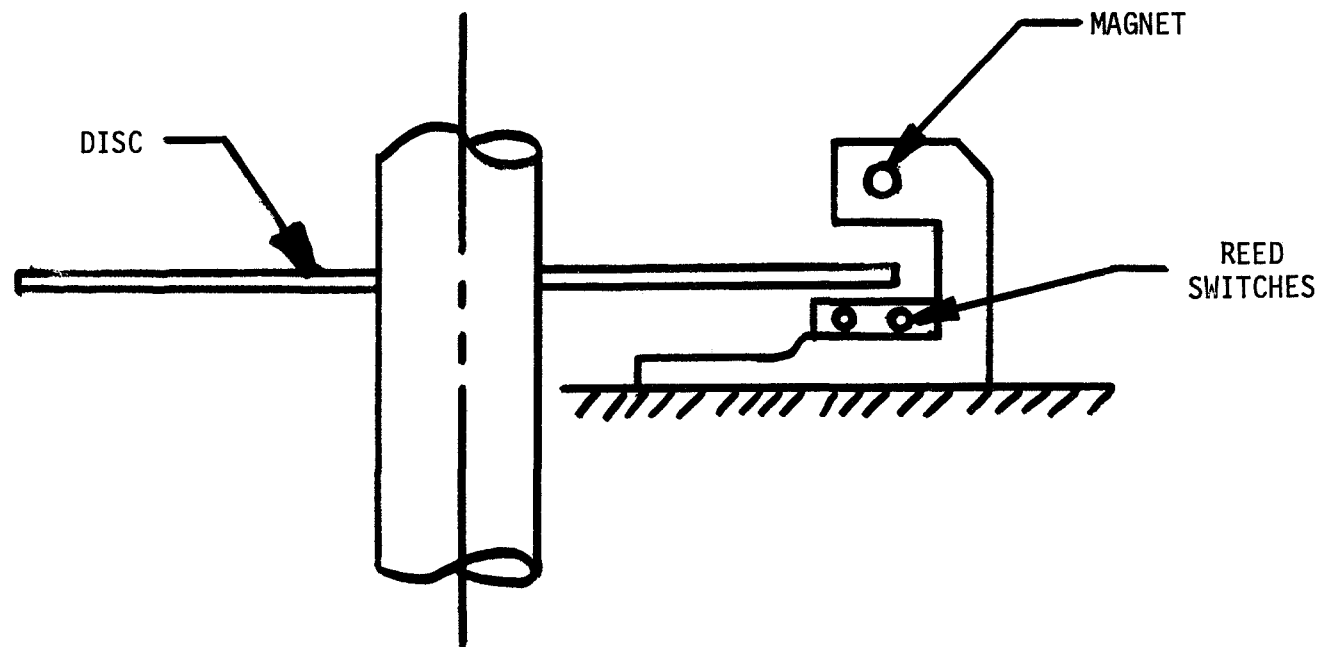

Figure 6. BSE Reed Switch Assembly

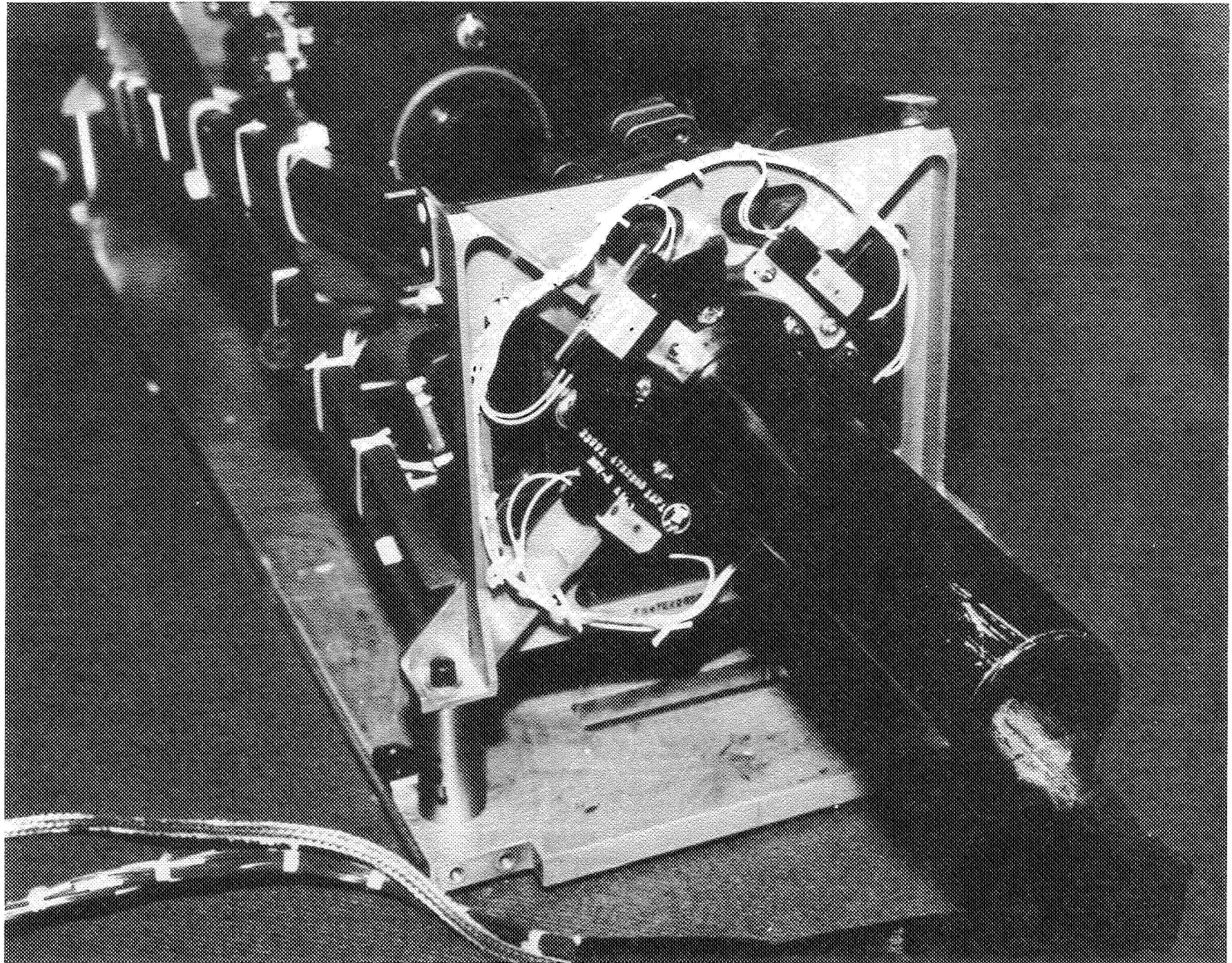

Figure 7. Reed Switches Assembled to BSE Solar Array Drive

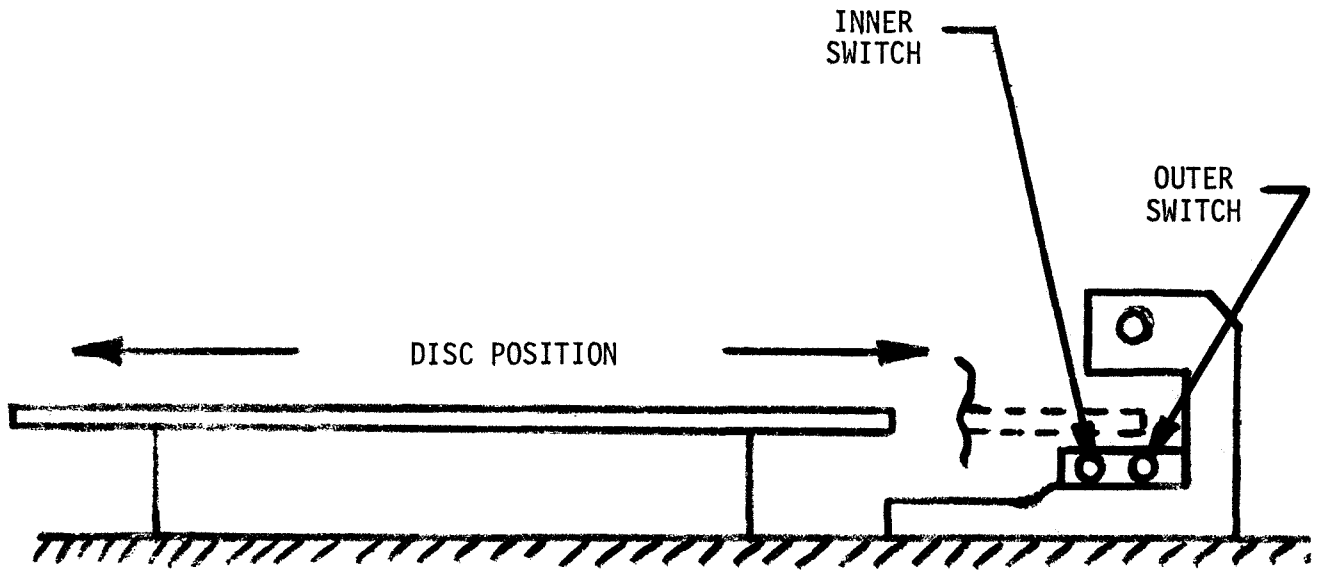

Figure 8. Reed Switch/Disc Test Fixture

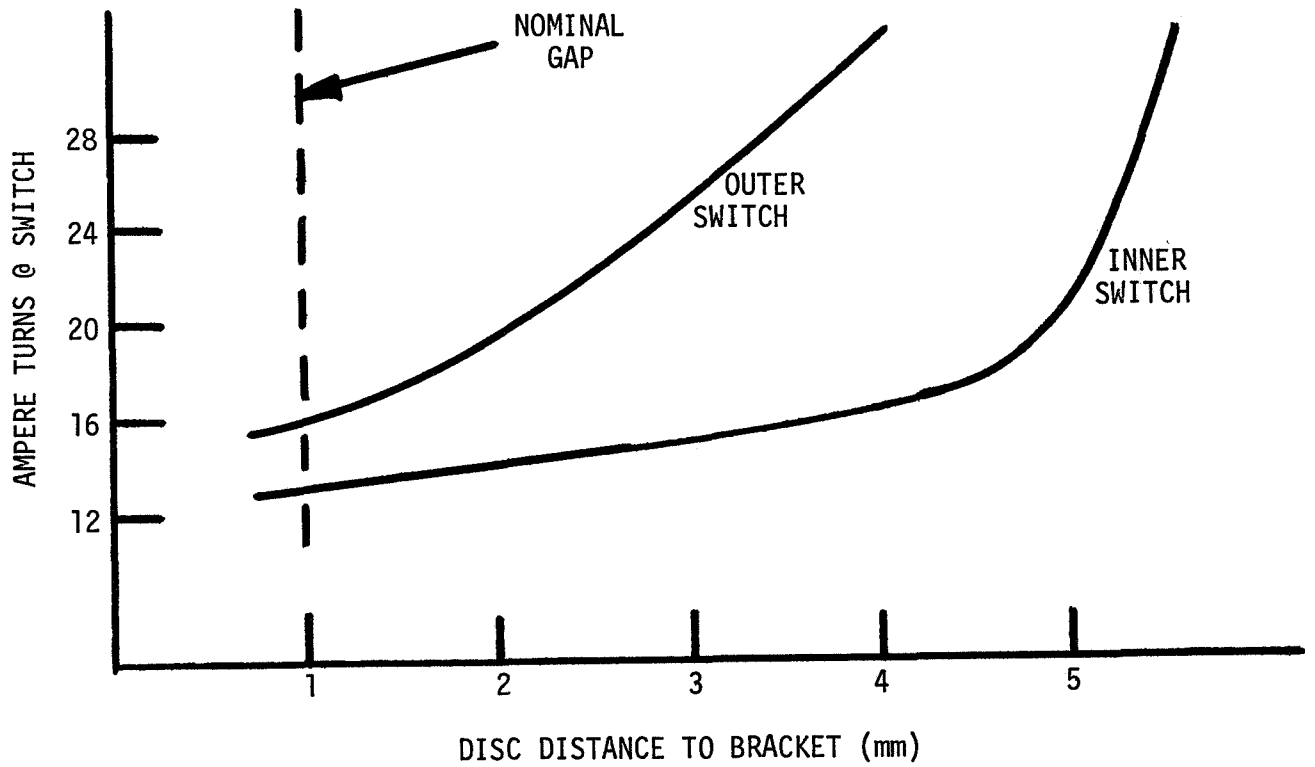

Figure 9. Effect of Disc Position on Magnetic Field

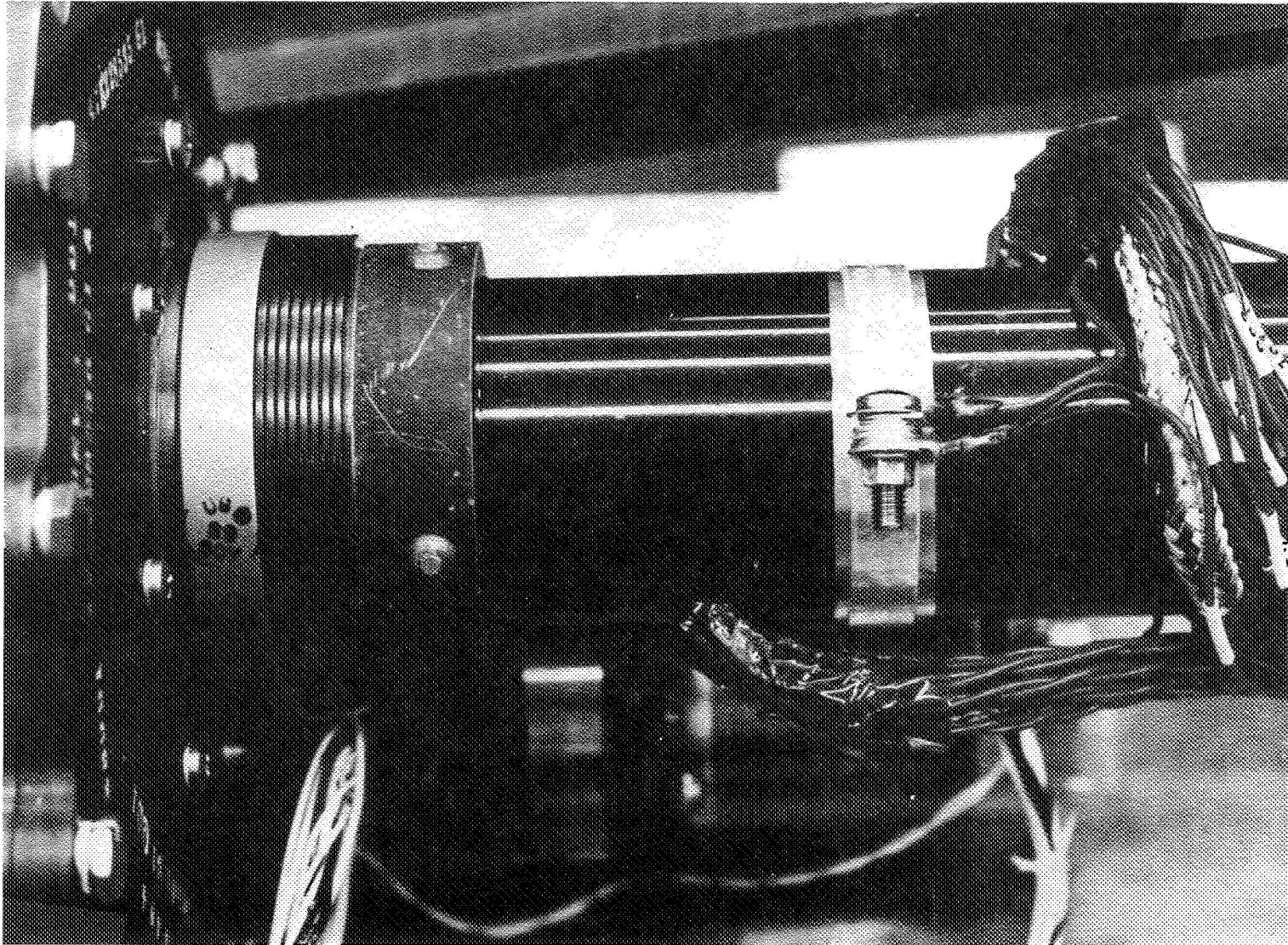

Figure 10. Wrap Spring Portion of BSE Solar Array Drive

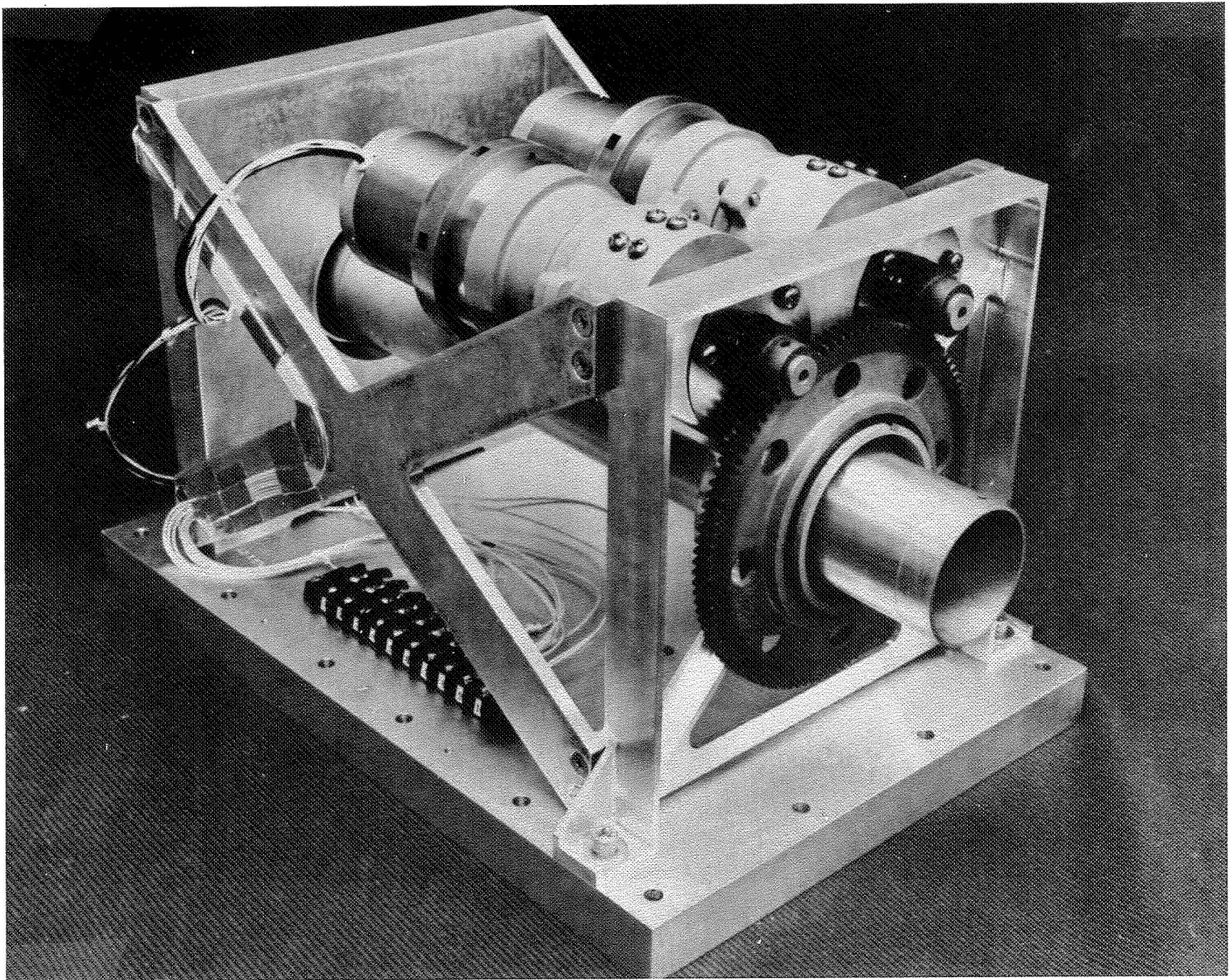

Figure 11. 'DSCS III Solar Array Drive - Engineering Model