

General Disclaimer

One or more of the Following Statements may affect this Document

- This document has been reproduced from the best copy furnished by the organizational source. It is being released in the interest of making available as much information as possible.
- This document may contain data, which exceeds the sheet parameters. It was furnished in this condition by the organizational source and is the best copy available.
- This document may contain tone-on-tone or color graphs, charts and/or pictures, which have been reproduced in black and white.
- This document is paginated as submitted by the original source.
- Portions of this document are not fully legible due to the historical nature of some of the material. However, it is the best reproduction available from the original submission.

April 20, 1979



AMERICAN
INSTITUTE OF
AERONAUTICS AND
ASTRONAUTICS

1290 AVENUE
OF THE AMERICAS
NEW YORK, N.Y. 10019
TELEPHONE
212 / 581-4300

TO: Mrs. Winnie M. Morgan

FROM: Ruth F. Bryans, Administrator, Scientific Publications

A back-up paper is enclosed for the following Synoptic:

Author(s): Manohar P. Kamat and Norman F. Knight Jr.

Title of Synoptic: "Nonlinear Transient Analysis via Energy Minimization"
Log No. J11101

Title of Back-up Paper: Same as above

Correspondence with: Dr. M. P. Kamat
Associate Professor
Engineering Science and Mechanics
Virginia Polytechnic Institute
and State University
Blacksburg, Virginia 24061



Journal: AIAA Journal

Scheduled Issue: August 1979

Ruth F. Bryans

(Miss) Ruth F. Bryans

Enclosure

(NASA-CR-158494) NONLINEAR TRANSIENT
ANALYSIS VIA ENERGY MINIMIZATION (Virginia
Polytechnic Inst. and State Univ.) 39 p HC
A02/MF A01 CSCI 12A

N79-22819

Unclas

G3/64 20547

NONLINEAR TRANSIENT ANALYSIS VIA
ENERGY MINIMIZATION

By

Manohar P. Kamat and Norman F. Knight, Jr.

October 27, 1979

Backup Document for AIAA Synoptic Scheduled
For Publication in the AIAA Journal, August 1979

Engineering Science and Mechanics
Virginia Polytechnic Institute
and State University
Blacksburg, Virginia 24061



Nonlinear Transient Analysis
via Energy Minimization*

by

Manohar P. Kamat⁺
Virginia Polytechnic Institute and State University

and

Norman F. Knight, Jr.⁺⁺
George Washington University Center
at NASA Langley Research Center

Abstract

The authors provide the formulation basis for nonlinear transient analysis of finite element models of structures using energy minimization. With both geometric and material nonlinearities included, the development is restricted to simple one and two dimensional finite elements which are regarded as being the basic elements for modeling full aircraft-like structures under crash conditions. The results presented establish the effectiveness of the technique as a viable tool for this purpose.

* This work was supported by NASA Langley Research Center under the grant NGR 47-004-114. Robert J. Hayduk was the responsible technical monitor.

+ Associate Professor, Department of Engineering Science and Mechanics, AIAA Member.

++ Graduate Research Assistant

Subject Category: Crashworthiness, Nonlinear Transient Analysis, Energy Minimization, Finite Elements.

I. Introduction

Nonlinear transient analysis of structures has been of increasing interest to engineers by virtue of their motivation for minimizing human and property damage resulting from the catastrophic failure of such structures under crash or seismic conditions. Complexities of the structural configuration and its equally complex transient response in the presence of material inelasticity make finite element modeling of such structures a very natural and plausible recourse. Portions of the structures may remain elastic and undergo infinitesimally small deformations while other portions may experience finite deformations and motions and respond inelastically under time-varying loads that may lead to a complete failure of the structure. If finite strains are to be permitted in the model, distinction must be made between undeformed and deformed configurations and the concepts of pseudo stresses and conjugate strain measures which have intricate physical interpretations must be introduced [1]. Furthermore, strictly speaking most elastic-plastic theories which hypothesize an additive decomposition of the total strain into an elastic and a plastic component lose their validity in the large strain domain [2]. Because of this, most developers of nonlinear analysis codes restrict themselves to a small strain formulation but permit finite displacements and rotations thereby allowing buckling and collapse of the structure to occur. There are some indications that this may be adequate for most practical purposes.

With this hypothesis as its basis, the present discussion focuses on the simulation of response of a structure modeled as an assemblage of membrane, frame (3-D beam), stringer elements and rigid links (see Figure 1). The mathematical model is a finite element displacement

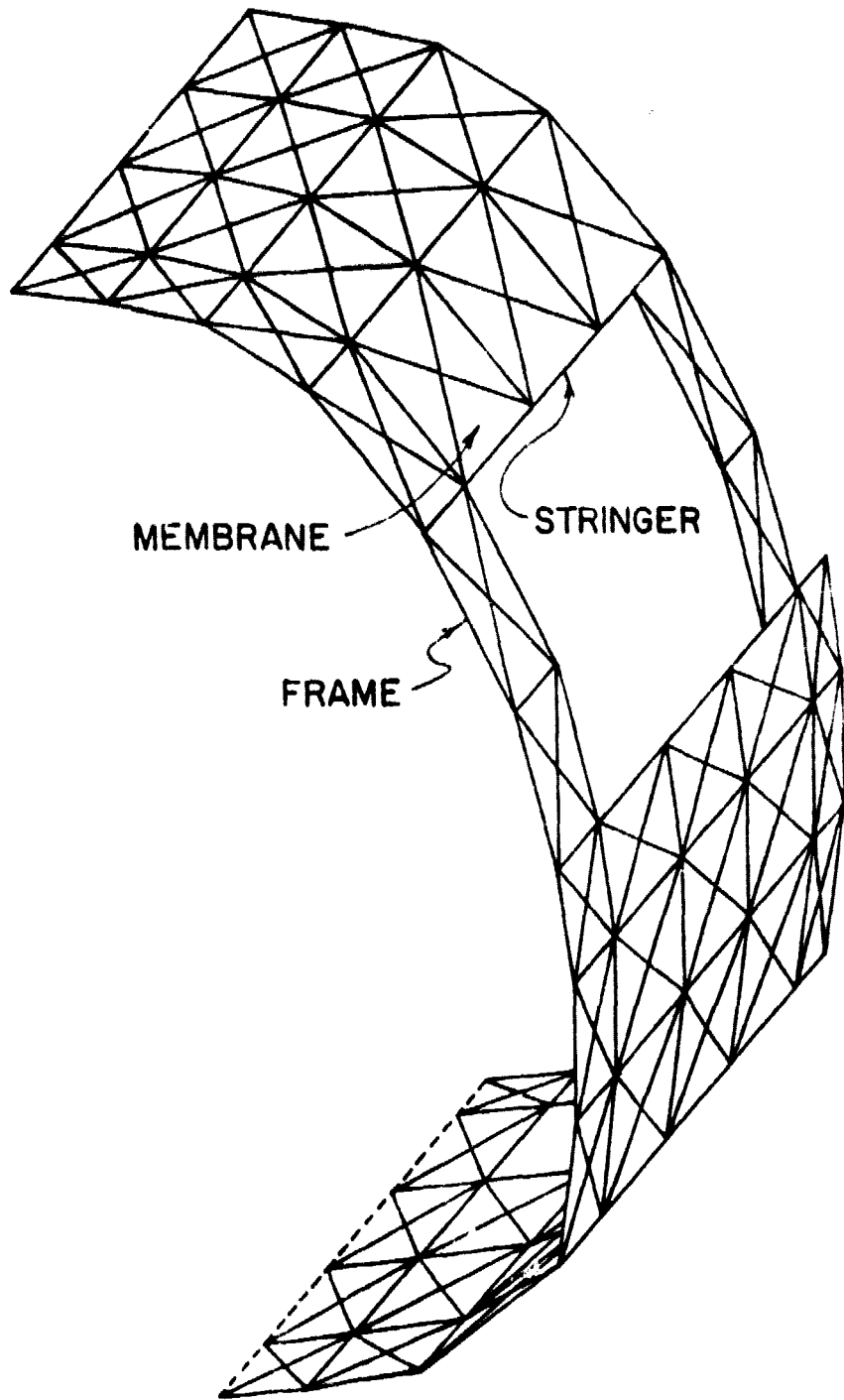

Figure 1

model which consists of discretizing the actual structure by an assemblage of finite elements and approximating the response of each element by a finite number of deformation states expressed as linear functions of the generalized nodal displacements.

Two distinct solution approaches exist: (i) the vector approach and (ii) the scalar approach. In the former, the mathematical model is derived on the basis of the principle of virtual work and reduces to a system of nonlinear second-order differential equations in time. In the latter approach, a scalar or potential function associated with the energy of the model is introduced, minimization of which yields the desired equilibrium configuration. In both approaches a temporal finite difference scheme is utilized to effectively eliminate time as a variable. As a result, in the vector approach the equations of motion are reduced to a system of nonlinear algebraic equations in the unknown nodal parameters of the finite element model^{[3]-[6]}. In the scalar approach, which is of relevance to this paper, the problem is reduced to a well known problem in mathematical programming namely the unconstrained minimization of a nonlinear function of several variables.

II. Minimization Technique for Nonlinear Analysis

a. Formulation Basis

The scalar approach has been successfully used for static and transient nonlinear structural analysis [7]-[9]. In this case the problem of response prediction is equivalently posed as the minimization of a potential function of the unknown nodal parameters of the finite element model. For all structural problems with geometric and material nonlinearities of the type considered herein such a potential function always exists. Although this technique has been hitherto used for mainly positive or negative definite systems, other systems which fail to be positive or negative definite can be handled by using the least squares method or the modified conjugate gradient method with preconditioning [10]. In some cases for such systems displacement incrementation rather than load incrementation in conjunction with conventional unconstrained minimization techniques can also be equally effective [11].

The minimization scheme as applied to the solution of transient nonlinear structural analysis problems consists of minimizing a potential function associated with the system for an assumed relationship between displacements and time. The displacement-time relation for each generalized nodal displacement of a finite element model may be assumed of the form [12]

$$q_{ei} = \beta(\Delta t)^2 \ddot{q}_{ei} + \left(\frac{1}{2} - \beta\right)(\Delta t)^2 \ddot{q}_{0i} + (\Delta t) \dot{q}_{0i} + q_{0i} \quad (1-a)$$

$$\dot{q}_{ei} = \gamma(\Delta t) \ddot{q}_{ei} + (1 - \gamma)(\Delta t) \ddot{q}_{0i} + \dot{q}_{0i} \quad (1-b)$$

where q_{ei} is the i -th generalized nodal displacement at the end of the time step and β and γ are constants. These constants are determined in terms of the i -th generalized nodal displacement, q_{0i} , velocity, \dot{q}_{0i} and acceleration, \ddot{q}_{0i} at the beginning of the time step and the generalized

nodal displacement, q_{ei} , at the end of the time step. It can be easily verified that the equation of equilibrium for an N degree of freedom system with lumped masses

$$M_i \ddot{q}_{ei} - F_i + \frac{\partial U}{\partial q_{ei}} = 0 \quad ; \quad i = 1, 2, \dots, N \quad (2)$$

correspond to the necessary conditions for the functional

$$S = \sum_{i=1}^N \left\{ \left[\frac{1}{2\beta(\Delta t)^2} q_{ei}^2 - \left(\frac{1}{\beta(\Delta t)^2} q_{0i} + \frac{1}{\beta(\Delta t)} \dot{q}_{0i} + \left(\frac{1}{2\beta} - 1 \right) \ddot{q}_{0i} \right) q_{ei} \right] M_i - F_i(t+\Delta t) q_{ei} \right\} + U + C \quad (3)$$

to be stationary. In Equation (3), U is the strain energy and C is an arbitrary constant. Thus, knowing q_{0i} , \dot{q}_{0i} and \ddot{q}_{0i} at time t for any given load F_i at time $(t+\Delta t)$, the functional S may be minimized with respect to the generalized nodal displacements, q_{ei} ($i=1, \dots, N$), in order to determine the corresponding stable equilibrium configuration. Thus, this scheme satisfies equilibrium at the end of the time step, thereby providing an implicit temporal integration scheme. The size of the time step is automatically controlled so that the error at half time based on interpolated configuration data is less than a prescribed change in total energy. In general, the strain energy U will be a nonlinear function (at the very least a quadratic) of the generalized nodal displacements q_{ei} . Details on the explicit evaluation of U as a function of q_{ei} will be touched upon later.

Of all the available techniques for unconstrained minimization only the quasi-Newton or the variable metric methods have been more frequently used for structural analysis, because of their higher effectiveness [13]. Again, unless one accounts for the sparsity of the variable metric, one has to almost invariably resort to some form of a conjugate gradient technique for problems wherein N is an extremely large number.

The extension of the minimization techniques to extremely large scale nonlinear structural analysis problems is a subject of separate research [14] in itself and is beyond the scope of this paper .

Most algorithms for unconstrained minimization seek a direction of travel and the amount of travel in that direction. The manner in which these are sought depends upon the sophistication of the particular algorithm invoked. Most often the directions of travel are sought in a manner which guarantees not only a decrease in the value of the function to be minimized at each iteration but also a convergence to the minimum in a finite number of iterations (usually $N+1$ for an N dimensional space) in the case of quadratic functionals. It is important to note that all functionals are very nearly quadratic in the neighborhood of the minimum. The iterative scheme is begun with an initial guess which is usually the null vector in the absence of other better estimates. For the variable metric or the conjugate gradient methods the required gradient of S is evaluated either analytically or by a finite difference operation on S . The use of an analytic gradient results in a substantial saving in computational effort. This saving is the result of not only a cheaper gradient evaluation but most often a faster convergence of the solution because of higher accuracy of all computed quantities [13]. The i -th component of the gradient of S can be written as

$$\frac{\partial S}{\partial q_{ei}} = M_i \ddot{q}_{ei} - F_i + \frac{\partial U}{\partial q_{ei}} \quad (4)$$

The term in Eq. (4) requiring significant computational effort is

$\frac{\partial U}{\partial q_{ei}}$ as it embraces the geometric and material nonlinearities. Using half-station central differences this is given by

$$\frac{\partial U}{\partial q_{ei}} = \frac{\sum_{k=1}^m U_k(q_{e1}, q_{e2}, \dots, q_{ei} + \frac{1}{2} \Delta q_{ei}, q_{ei+1}, \dots, q_{eN})}{\Delta q_{ei}} - \frac{\sum_{k=1}^m U_k(q_{e1}, q_{e2}, \dots, q_{ei} - \frac{1}{2} \Delta q_{ei}, q_{ei+1}, \dots, q_{eN})}{\Delta q_{ei}} \quad (5)$$

where Δq_{ei} is a small change in the i -th component and m is the number of members or elements which has the i -th degree of freedom in common. In evaluating the gradient vector analytically [17], each of its component involves the evaluation of only a single function similar to the function for member energy evaluation. Thus,

$$\frac{\partial U}{\partial q_{ei}} = \sum_{k=1}^m \int_{v_k} \frac{\partial W}{\partial q_{ei}} dv_k = \sum_{k=1}^m \int_{v_k} \left(\frac{dW}{d\bar{\epsilon}} \right)_k \left(\frac{\partial \bar{\epsilon}}{\partial q_{ei}} \right)_k dv_k \quad (6-a)$$

where

W = strain energy density

$$\bar{\epsilon} = \text{effective strain} \begin{cases} = \frac{2}{\sqrt{3}} (\epsilon_{xx}^2 + \epsilon_{yy}^2 - \epsilon_{xx}\epsilon_{yy} + \frac{3}{4} \gamma_{xy}^2)^{1/2} & \text{for a two dimensional stress state} \\ = \epsilon_{xx} & \text{for a uniaxial stress state} \end{cases} \quad (6-b)$$

and for one step incremental loading or unloading

$$\left(\frac{dW}{d\bar{\epsilon}} \right) = \bar{\sigma} = \text{effective stress} \begin{cases} = (\sigma_{xx}^2 + \sigma_{yy}^2 - \sigma_{xx}\sigma_{yy} + 3\tau_{xy}^2)^{1/2} & \text{for a two dimensional stress state} \\ = \sigma_{xx} & \text{for a uniaxial stress state} \end{cases} \quad (6-c)$$

Equations (6-a) through (6-c) imply the use of Hencky's total strain theory along with its assumption that in the strain hardening range the inelastic component of the total strain is predominant [15]. This in a way is consistent with the assumption that the total strain can be decomposed into an elastic and a plastic part especially in cases where the strains are large [2]. According to reference [2] it is only when

plastic strains are predominant that such a decomposition is justified.

The problem at hand could have equally well been formulated using the incremental flow theories of plasticity in the strain hardening range. The potential function instead of being a function of the total quantities need then be expressed in terms of incremental quantities and the minimization technique can still be used [16]. As a matter of fact, it may be conjectured that the performance of the solution algorithm will perhaps be significantly improved using such a formulation even though the material model may then be slightly more complex. In any event, it is immediately obvious that a significant reduction in computational time will be realized if analytic gradients are used in preference to central difference gradients.

The complexity of the strain energy evaluation for any element is determined by its deformation model. This is discussed next.

b. Deformation model:

The deformation model of the entire structure is synthesized from deformation states of each element of the structure. These states are expressed in terms of generalized displacements of the nodes of the structure at which the elements interface.

The displacement field within each element is chosen as a continuously differentiable function of the local spatial coordinates and the generalized nodal displacements. The field maintains interelement continuity of its essential derivatives thereby providing a Galerkin model of the system. The local generalized nodal displacements of each element are then related to the global displacements of the assemblage. These relations, which can be interpreted as transformations of the local coordinate system to the global coordinate system, may be linear

or nonlinear depending upon whether the motions and deformations of the elements are infinitesimal or finite. For large rigid body rotations, these transformations are accomplished using Euler angles which are linearly independent by virtue of the fact that the rotations are performed in a prescribed order.

There are three kinematic descriptions most commonly used for characterizing large displacements of finite element models of structures. These are: (i) the total Lagrangian formulation wherein the initial undeformed configuration is the reference configuration, (ii) the updated Lagrangian formulation which uses a total Lagrangian formulation within each load or time step but updates the reference configuration at the end of each step and (iii) the co-rotational or rigid convected coordinate formulation which utilizes a coordinate system rigidly attached to an element and moving with the element. For development of a large rotation formulation vital for crashworthiness studies the use of the total Lagrangian formulation is unsuitable since most structural theories permit only moderately small rotations [18]. The co-rotational formulation decomposes the total displacements into a rigid body motion component and a strain producing component. Thus, with the restriction of small relative rotations within the element, this formulation leads to a simplification of the strain-displacement relationship on the element level while still permitting arbitrarily large rotations of the element. The present deformation model uses the co-rotational or rigid-convected formulation for its kinematic description.

Through appropriate kinematic constraints modeling of massless degrees of freedom or of deformation-free rigid links or even the simulation of contact with an impenetrable, rough plane are easily achieved.

Rigid links can be used to simulate either joint eccentricities or rigid parts of a structure. In the interest of a truly unconstrained minimization Lagrange multipliers or penalty functions are avoided. Rather kinematic constraints are formulated as prescribed displacements under reactive forces provided by the gradients of the strain energy with respect to the corresponding degrees of freedom.

c. Material model:

Although closed form analytic expressions for U can be developed when the material is elastic the same is not true when elements yield. Then the response depends upon the current values of stress components and the past history. Von Mises' yield criterion together with Hencky's total strain theory provides a simple means of calculating strain energy density distributions throughout an element that has yielded. Because total stresses and total strains are no longer linearly related recourse must be made to numerical integration (Gaussian or Lobatto) of the strain energy density over the volume of the element. Thus, a frame element which was strictly a uniaxial member in the elastic range, typified by its cross-sectional area and moments of inertia, requires a full three dimensional characterization in the inelastic range. In other words, frame elements for inelastic analysis require a classification based on the different cross-sections. This development is restricted to frame elements with thin-walled sections of the closed and open (Box, Tube, Elip and E) variety - a characteristic of general aviation aircraft frames. However, in the elastic range the development does permit frame elements with arbitrary cross-sections characterized by their gross section properties. In the interest of simplicity, classical shear flow theory for thin-walled sections is used and certain

simplifying assumptions regarding torsion, warping and shear deformations in the inelastic range are introduced. This is characteristic of most nonlinear analyzers mainly because the development of a truly three-dimensional frame element for nonlinear inelastic response is a formidable task perhaps even more challenging than that of the development of a plate bending or a shell element for the same purpose. In fact, in the inelastic range it may be easier to model a thin-walled beam of arbitrary cross-section by an assemblage of a large number of plate and shell elements thereby permitting a faithful representation of very complex effects like restrained warping, torsion, cross-sectional distortions, etc.

Thus, it is clear that when an element yields, the complexity of the strain energy evaluation increases several times in relation to its purely elastic behavior. A number of quadrature points have to be assigned over the volume of the element and using the material model stresses and strain energy densities have to be evaluated at each of these points for known values of strains (Figure 2). The average strain energy density which is simply the weighted sum of these strain energy densities then enables the calculation of the total strain energy. It must be noted, however, that the stress-strain history at each of these quadrature points, which corresponds to a unique location on an idealized effective stress-effective strain curve for the material of the element (Figure 3), must be made available at all times. This places highly increased demands on computer storage as inelastic deformations progress with time.

The material is assumed to unload elastically. For modeling plasticity under cyclic loading kinematic hardening with an idealized

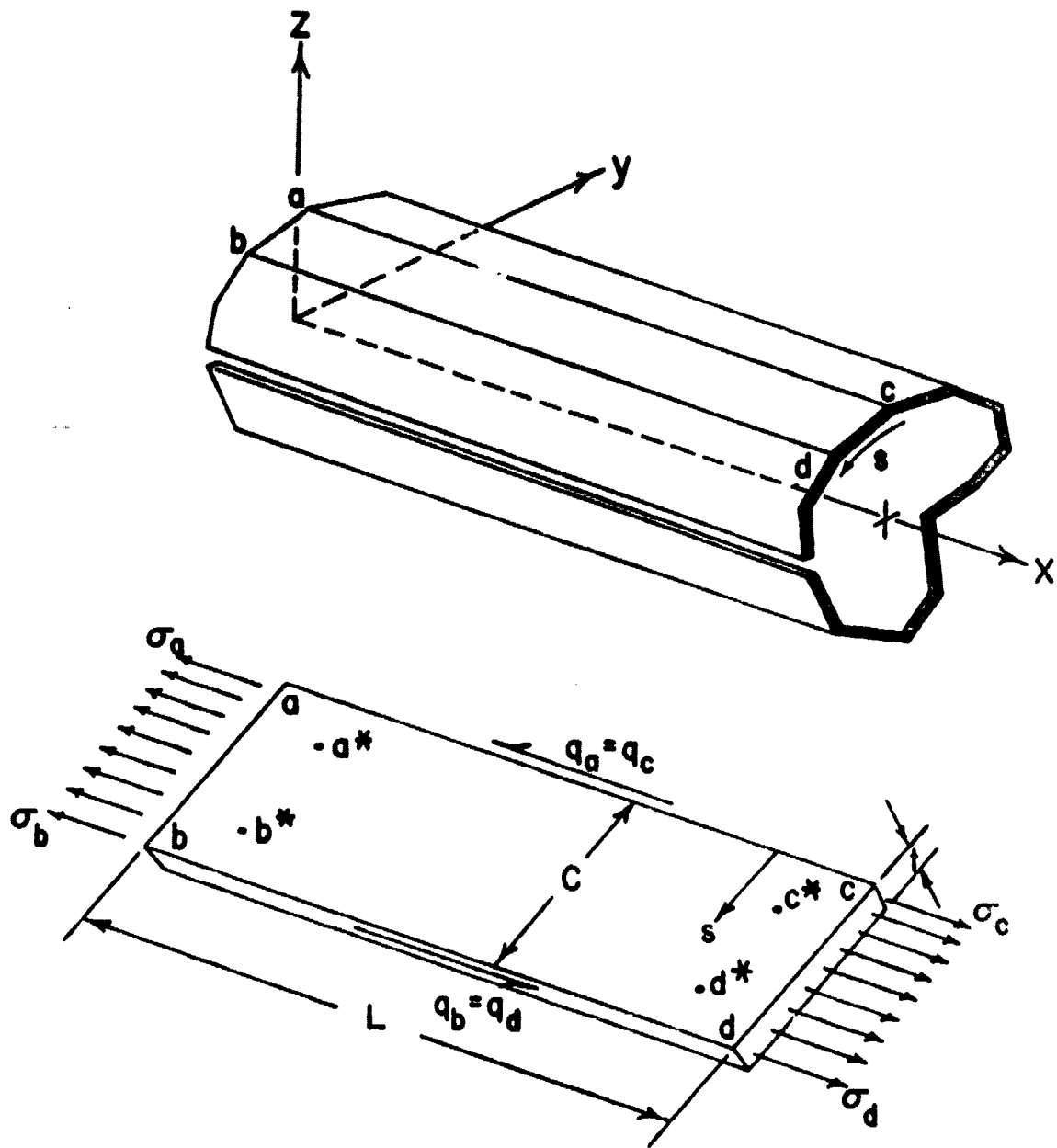

Figure 2

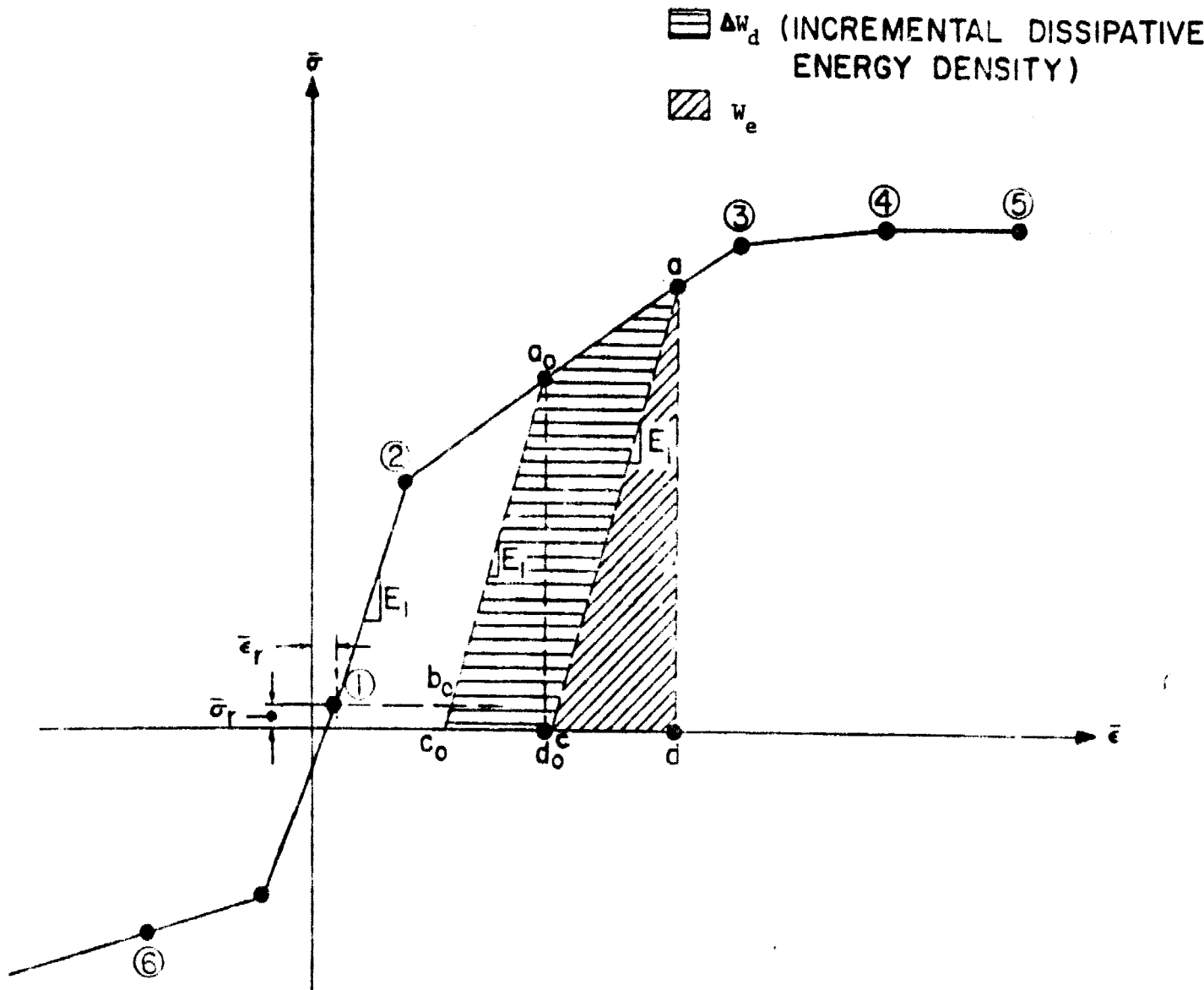

Figure 3

Bauschinger effect is assumed. Specialized elements like the gap elements and stays can be easily modeled simply through an appropriate modification of the material model of the conventional elements.

The details of the total strain energy calculations for the different element types considered and the transformations relating element behavior to global variables is relegated to the appendix.

III. Results and Discussion

The effectiveness of the minimization technique in solving nonlinear problems is very much a function of not only the size of the load or time step but also the extent and type of the nonlinearity-geometric or material and even the type of the temporal discretization scheme used which is to say the assumed values of β and γ in Eq. (1). With this in mind, the process of selection of problems for validation was geared towards providing an evaluation of the techniques under different types of nonlinearities. Problems belonging to three distinct classes namely: (i) quasi-static, elastic with geometric nonlinearities, (ii) quasi-static, elastic-plastic with geometric nonlinearities and (iii) transient, elastic-plastic with geometric nonlinearities were selected. Independent solutions or experimental results for these problems were available for comparison purposes.

Figure 4 shows the case of a rod-spring problem wherein the stiffness of the spring is just enough to prevent a snap-through and provide a single-valued load deflection response. Most researchers regard this problem as geometrically highly nonlinear. Using stringer elements with load steps as high as 1 lb., the energy minimization solution is indistinguishable from the easily obtainable exact solution to this problem. Higher load steps could have been chosen but caution must be exercised with extremely large load steps since the performance (the number of minimizations required for convergence) of the minimization algorithm may be adversely affected. In other words, the computational effort within a load step may increase substantially enough to offset the savings accrued from fewer load steps.

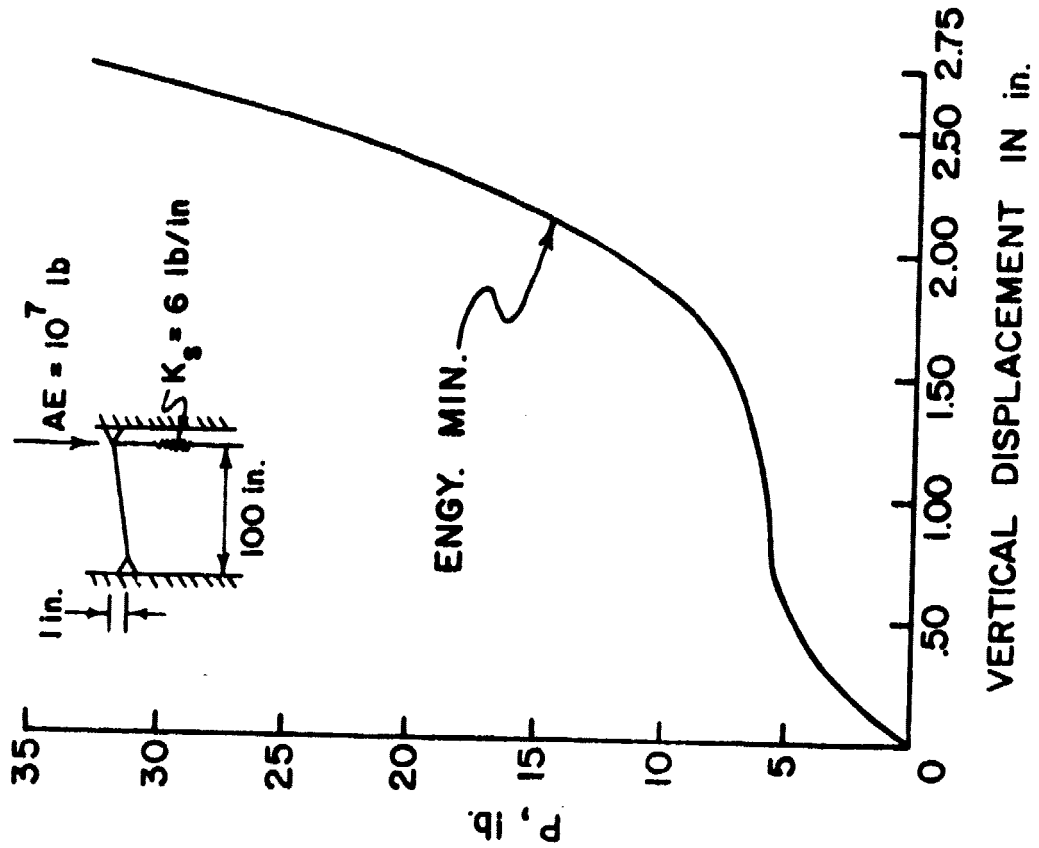

Figure 4

Figure 5 provides yet another example of such a nonlinearity except that in this case the load response curve is no longer single valued but is a composite of stable and unstable branches. Using straight-forward load incrementation, it is possible to locate only the stable equilibrium configurations as indicated in Figure 5. Using displacement incrementation, however, the entire load response curve can be easily obtained. The response predicted by energy minimization agrees very closely with that predicted by the nonlinear analyzer developed by Stricklin and Haisler [19] for an identical model of the shallow arch using frame elements.

While both of the previous problems involved only geometric nonlinearities, Figure 6 presents the case wherein both material and geometric nonlinearities interact. The experimental prediction of the post-buckling, elastic-plastic response of this beam-column with a thin-walled channel cross-section was the result of a test carried out by Anderson et al [20]. To prevent failure by direct compression, the column was tested at an inclination of 5° from the vertical with both ends of the column being clamped. A column under these conditions is highly imperfection sensitive and hence Anderson et al assume an additional 1° offset, as shown in the figure, for the mathematical model hoping to simulate the inherent imperfections of the actual column tested. Because the response involves a highly unstable branch, displacement incrementation had to be used in place of load incrementation. The response predicted by energy minimization agrees extremely well with the experimental prediction and even more so by comparison with that predicted using UMVCS-1[21].

$$y = a \sin(\pi x/L) \quad a = 5 \text{ in.} \quad L = 100 \text{ in.}$$

$$A = 0.32 \text{ in.}^2 \quad I = 1 \text{ in.}^4 \quad E = 10^7 \text{ psi}$$

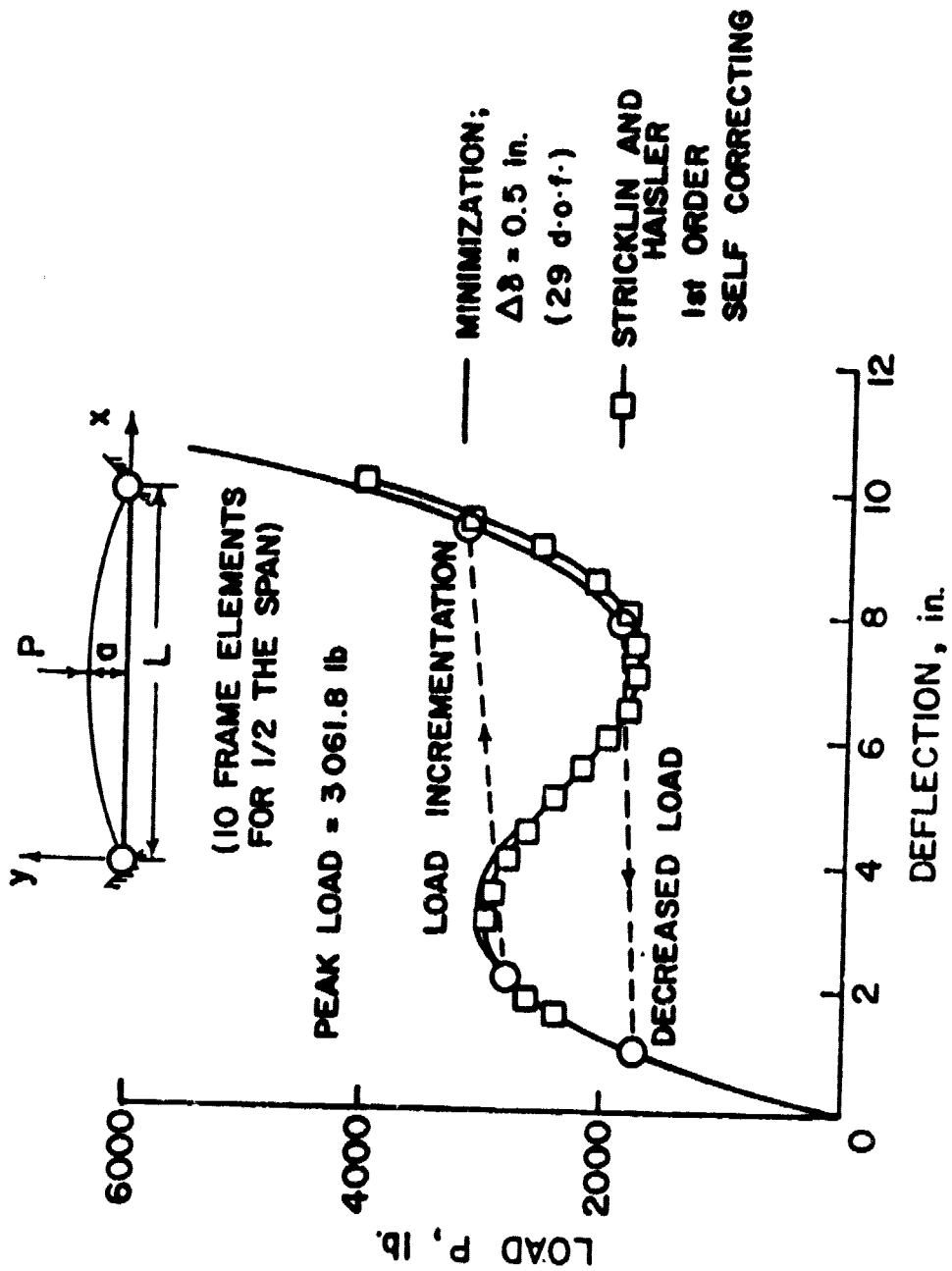

Figure 5

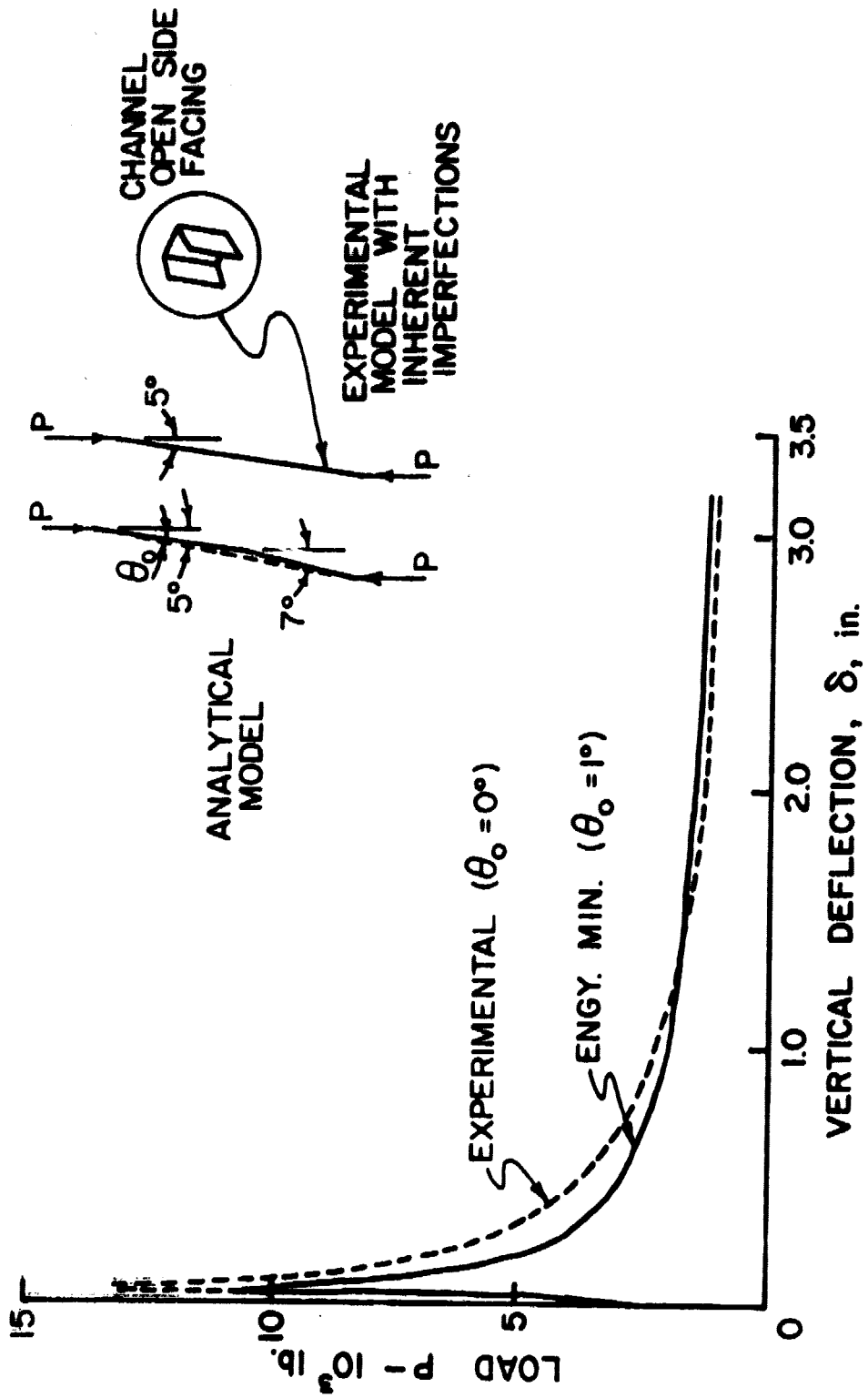

Figure 6

Figure 7 illustrates the case of the transient response in the presence of both geometric and material nonlinearities. The impulse is large enough to cause the entire beam to respond inelastically while experiencing moderately large relative rotations. The experimental response for this beam was obtained by Krieg et al [22]. It is immediately obvious that the quality of the response prediction is very much a function of the values of β and γ . This is not to say that optimum values of β and γ exist which guarantee optimum fidelity of the response prediction. As a matter of fact, optimum values of β and γ appear to be very much problem dependent. Again, the response may be significantly affected by the use of a consistent mass matrix and with rotatory inertia and shear deformation effects included.

With the possible exception of the problem of Figure 8, all the previous problems involved only a relatively few degrees of freedom. Furthermore, the state of stress in all of these problems was essentially uniaxial for all practical purposes. Using constant strain membrane elements the maximum strain in the vicinity of a notch in the direction of loading is determined and compared with the experimental results. The agreement between the two predictions is good but could perhaps be improved upon by the use of nonlinear strain displacement relationships in the co-rotational coordinate system.

This demonstration of the effectiveness of the minimization technique as a tool for nonlinear analysis has been, no doubt, restricted to classical, idealized problems with a relatively few degrees of freedom. Extensions to large scale problems like the section of an aircraft, as in Figure 1, or even a full aircraft may involve several thousands of

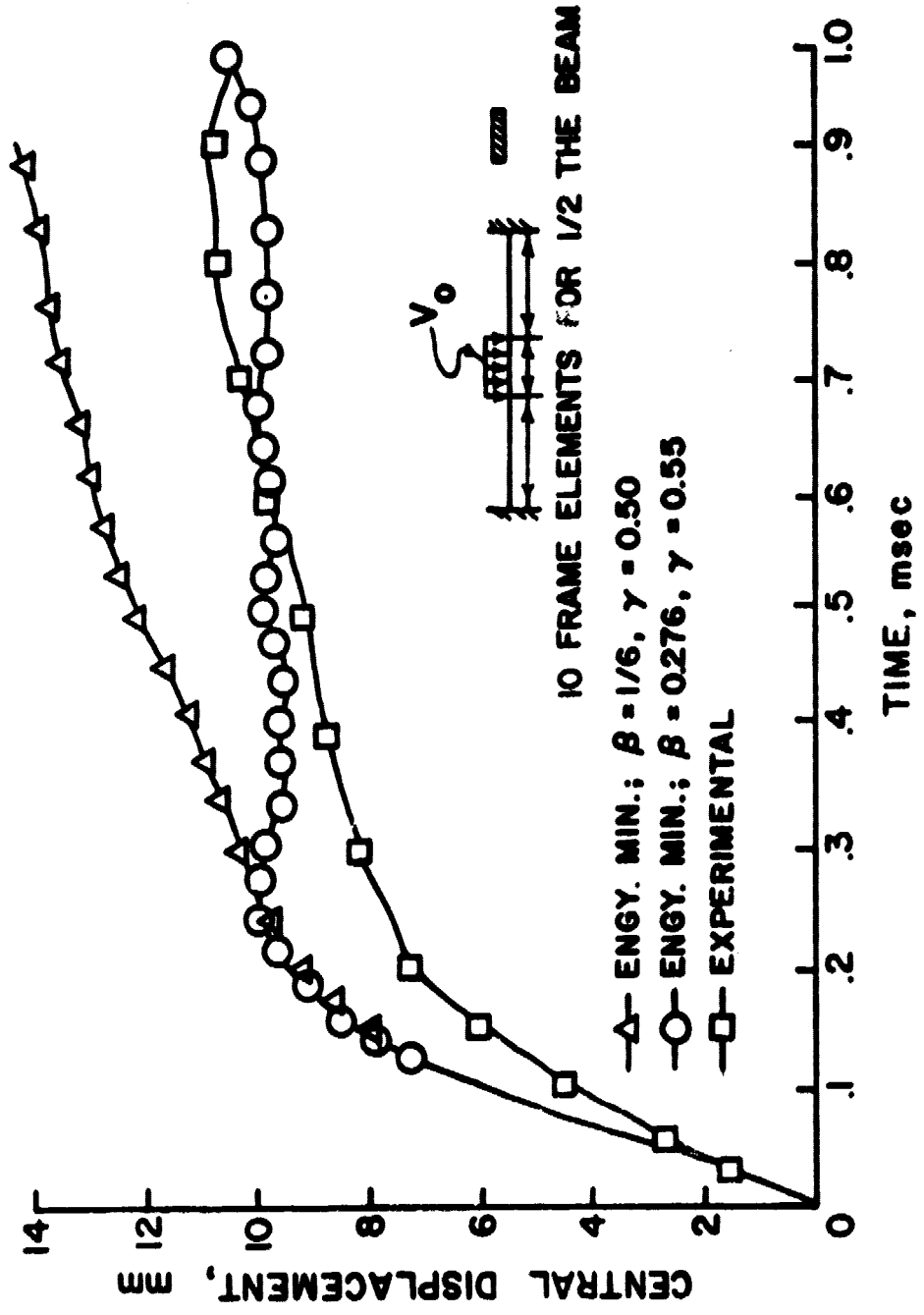
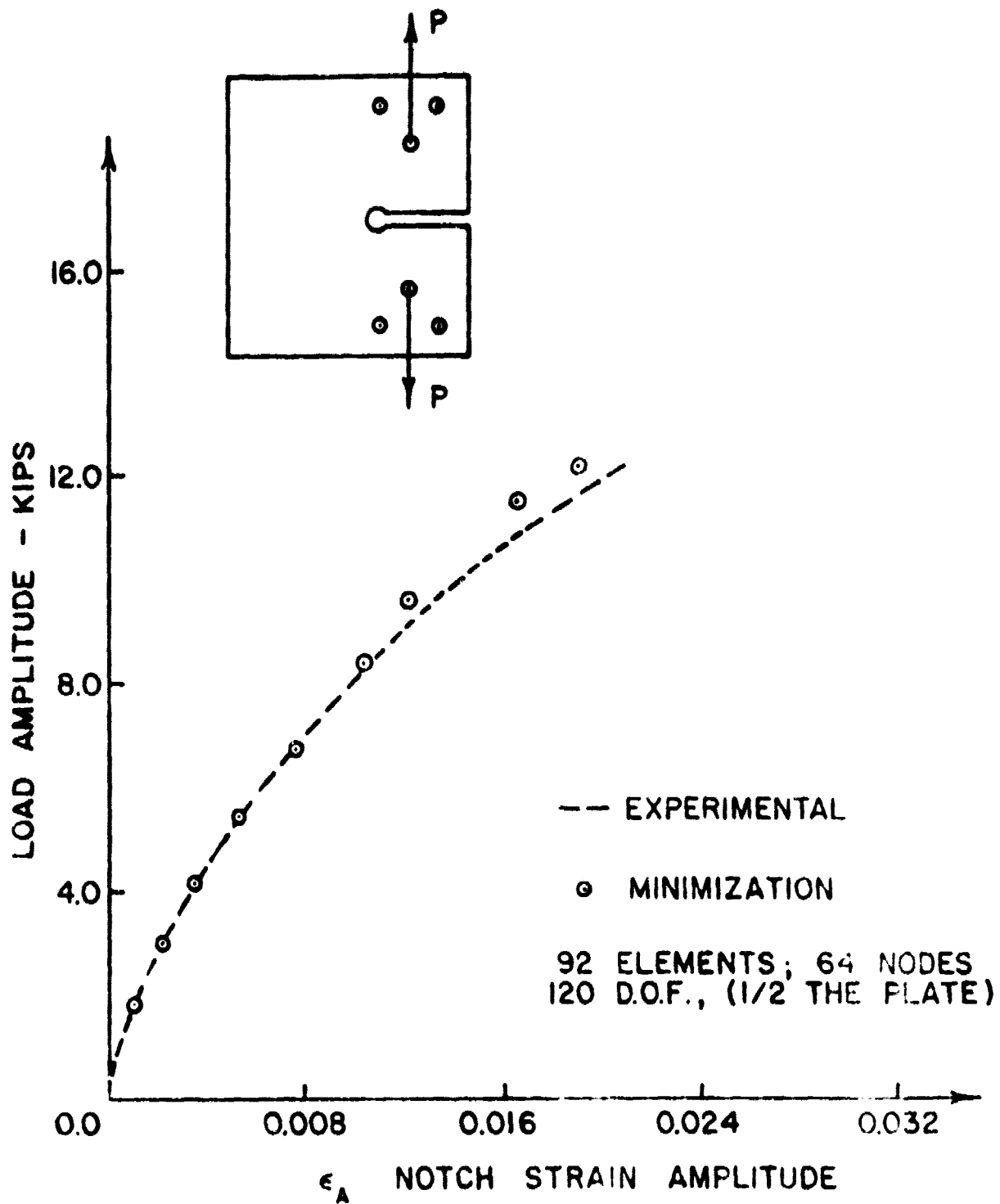

Figure 7



degrees of freedom. The effectiveness of the present technique for response prediction of such structures remains to be demonstrated. Using preconditioned conjugate gradient technique or variable metric methods which exploit sparsity, it is believed that this is no longer an insurmountable task. Its performance vis-a-vis the pseudo force and hybrid techniques for such large scale problems will be the subject of a follow-on paper. Incidentally, however, for small scale problems of the type considered herein the energy minimization technique has been shown to be at least comparable to, if not better than, the pseudo force technique [14].

Acknowledgements

The development of the computer code used for the solution of problems of Figures 4 through 8 was the work of several people including the authors. Although, many of them have no longer been associated with its development for quite some time, their contributions are nonetheless gratefully acknowledged.

References

- [1] Oden, J. T., Finite Elements of Nonlinear Continua, McGraw-Hill, N. Y., 1972.
- [2] Lee, E. H., "Elastic-Plastic Deformation at Finite Strains", J. Appl. Mech., Trans. ASME, March 1969, pp. 1-6.
- [3] Bathe, K. J., Wilson, E. L. and Iding, R. H., "A Structural Analysis Program for Static and Dynamic Response of Nonlinear Systems", Report No. UCSESM 74-3, University of California, Berkeley, California, February 1974.
- [4] Heifitz, J. H. and Constantino, C. J., "Dynamic Response of Nonlinear Media at Large Strains", J. EM. Div., ASCE, EM6, 1972, pp. 1511-1528.
- [5] Armen, H., Jr., Pifko, A. and Levine, H., "Nonlinear Finite Element Techniques for Aircraft Crash Analysis", Aircraft Crashworthiness, ed. K. Saczalski, et al, University Press of Virginia, Charlottesville, 1975, pp. 517-548.
- [6] Yeung, K. S. and Welch, R. E., "Refinement of Finite Element Analysis of Automobile Structures Under Crash Loading", Vol. II. U.S. D.O.T., NHTSA, 1977.
- [7] Bogner, F. K., Mallet, R. H., Minich, M. D. and Schmit, L. A., "Development and Evaluation of Energy Search Methods of Nonlinear Structural Analysis", AFFDL-TR-65-113, WPAFB, Dayton, Ohio, 1966.
- [8] Mallet, R. H. and Berke, L., "Automated Method for Large Deflection and Instability Analysis of Three Dimensional Truss and Frame Assemblies", AFFDL-TR-66-102, WPAFB, Dayton, Ohio, 1966.
- [9] Young, J. W., "CRASH: A Computer Simulation of Nonlinear Transient Response of Structures", DOT-HS-091-1-125-13, March 1972.
- [10] Widlund, O., "Conjugate Gradient Methods for Systems of Linear Equations Which Fail to be of Positive Definite Symmetric Type", Lecture delivered at ICASE, NASA Langley Research Center, Hampton, Va., June 1978.
- [11] Kamat, M. P., "An Investigation into the Effect of Beam Cross-Sectional Flexibility on Response", Virginia Polytechnic Institute and State University Report (to be published).
- [12] Newmark, N. M., "A Method of Computation for Structural Dynamics", J. EM. Div., ASCE, Vol. 85, 1959, pp. 67-94.
- [13] Kamat, M. P. and Knight, M. F., Jr., "Efficiency of Unconstrained Minimization Techniques in Nonlinear Analysis", NASA CR-2991, May 1978.

- [14] Kamat, M. P. and Hayduk, R. J., "On Minimization Techniques for Nonlinear Analysis" (to be published).
- [15] Smith, O. J. and Sidebottom, O. M., Inelastic Behavior of Load-Carrying Members, John Wiley and Sons, Inc., 1965.
- [16] Washizu, K., Variational Methods in Elasticity and Plasticity, Pergamon Press, 1968.
- [17] Knight, N. F., Jr., "An Efficiency Assessment of Selected Unconstrained Minimization Techniques as Applied to Nonlinear Structural Analyses", M.S. Thesis, Virginia Polytechnic Institute and State University, August 1977.
- [18] Belytschko, T., "Nonlinear Analysis Description and Numerical Stability", Shock and Vibration Computer Programs - Reviews and Summaries, ed. W. Pilkey and B. Pilkey, SVM-10, 1975.
- [19] Stricklin, J. A. and Haisler, W. E., "Survey of Solution Procedures for Nonlinear Static and Dynamic Analyses", SAE Intern. Conf. Vehicle Structural Mechanics, Detroit, Michigan, March 1974.
- [20] Anderson, W. J., McIvor, I. K. and Kimball, B. S., "Modular Program Development for Vehicle Crash Simulation", Vol. 2, Plastic Hinge Experiments, University of Michigan Report, Nov. 1976.
- [21] McIvor, I. K., Wineman, A. S. and Wang, H. C., "Large Dynamic Plastic Deformation of General Frames", Proceedings of the 12th Annual Meeting of the Society of Engineering Sciences, Austin, Texas, November 1975, pp. 1181-1190.
- [22] Krieg, R. D., Duffey, T. A. and Key, W. S., "The Large Deflection Elastic-Plastic Response of Impulsively Loaded Beams - A comparison Between Computations and Experiment", Sandia Laboratories Report SC-RR-68-226, July 1968.
- [23] Kamat, M. P. and Killian, D. E., "Some Inconsistencies of the Finite Element Method as Applied to Inelastic Analyses", NASA CR-2732, December 1976.

Appendix

Evaluation of the Total Strain Energy

The scalar approach for the solution of problems of structural analysis requires that the strain energy of the system be expressed, explicitly or implicitly, as a function of the global generalized nodal displacements of the finite element model.

From a known vector of the generalized nodal variables in the global co-ordinate system, consistent with the prescribed boundary conditions, a vector of local generalized variables in the co-rotational co-ordinate system of each element is established through transformations which are functions of its geometry and its rigid body rotations. The assumption of deformation patterns of the element as functions of these local generalized nodal variables (interpolating polynomials) yields element strains. Recourse to the element material model then yields the corresponding stresses and strain energy densities at various predetermined points (quadrature points) over the extent of the element. Barring purely elastic response, a simple weighted summation of these quantities over the element volume yields stress resultants and strain energies respectively. For purely elastic response these are provided by well-known closed form expressions. For the elastic-plastic response the strain energy density may be decomposed into an elastic part and an incremental-dissipative part thereby providing an estimate of the total energy of the system that has been dissipated through inelastic deformations. Thus, as shown in Figure 3 for a system with M elements

$$U = \sum_{i=1}^M U^i = \sum_{i=1}^M U_e^i + \Delta U_d^i = \sum_{i=1}^M \left(\int_{V_i} W_e^i dv + \int_{V_i} \Delta W_d^i dv \right) \quad (A-1)$$

where the dissipative energy ΔU_d^i is the incremental dissipative energy

computed from the previous stress state typied by the point a_0 on the effective stress-effective strain curve of Figure 3.

In the following sections expressions for the strain-displacement relations are developed for the different elements.

(i) Stringer Element

A structural component of uniform cross section which is initially straight and which is capable of resisting only axial loads is known as a stringer element.

From Figure (A-1) it can be seen that for assumed nodal displacements (U_p, V_p, W_p) and (U_q, V_q, W_q) of nodes p and q, the change in length, DL, of the element is given by

$$DL = [(X_q + U_q - X_p - U_p)^2 + (Y_q + V_q - Y_p - V_p)^2 + (Z_q + W_q - Z_p - W_p)^2]^{1/2} - [(X_q - X_p)^2 + (Y_q - Y_p)^2 + (Z_q - Z_p)^2]^{1/2} \quad (A-2)$$

which can be simplified to

$$DL = L \left[1 + \frac{2(\Delta X \Delta U + \Delta Y \Delta V + \Delta Z \Delta W)}{L^2} + \frac{\Delta U^2 + \Delta V^2 + \Delta W^2}{L^2} \right]^{1/2} - 1 \quad (A-3)$$

Δ being the difference operator for q and p end values. Assumption of the usual linear interpolation function in the co-rotational co-ordinate system then yields

$$\epsilon = \left(\frac{X}{L} \right) \left(\frac{DL}{L} \right) \quad (A-4)$$

(ii) Frame Element (3D Beam)

A frame element (Figure A-2) is a structural component which is initially straight and which undergoes axial, bending and torsional deformations resulting from finite displacements and rotations of its ends.

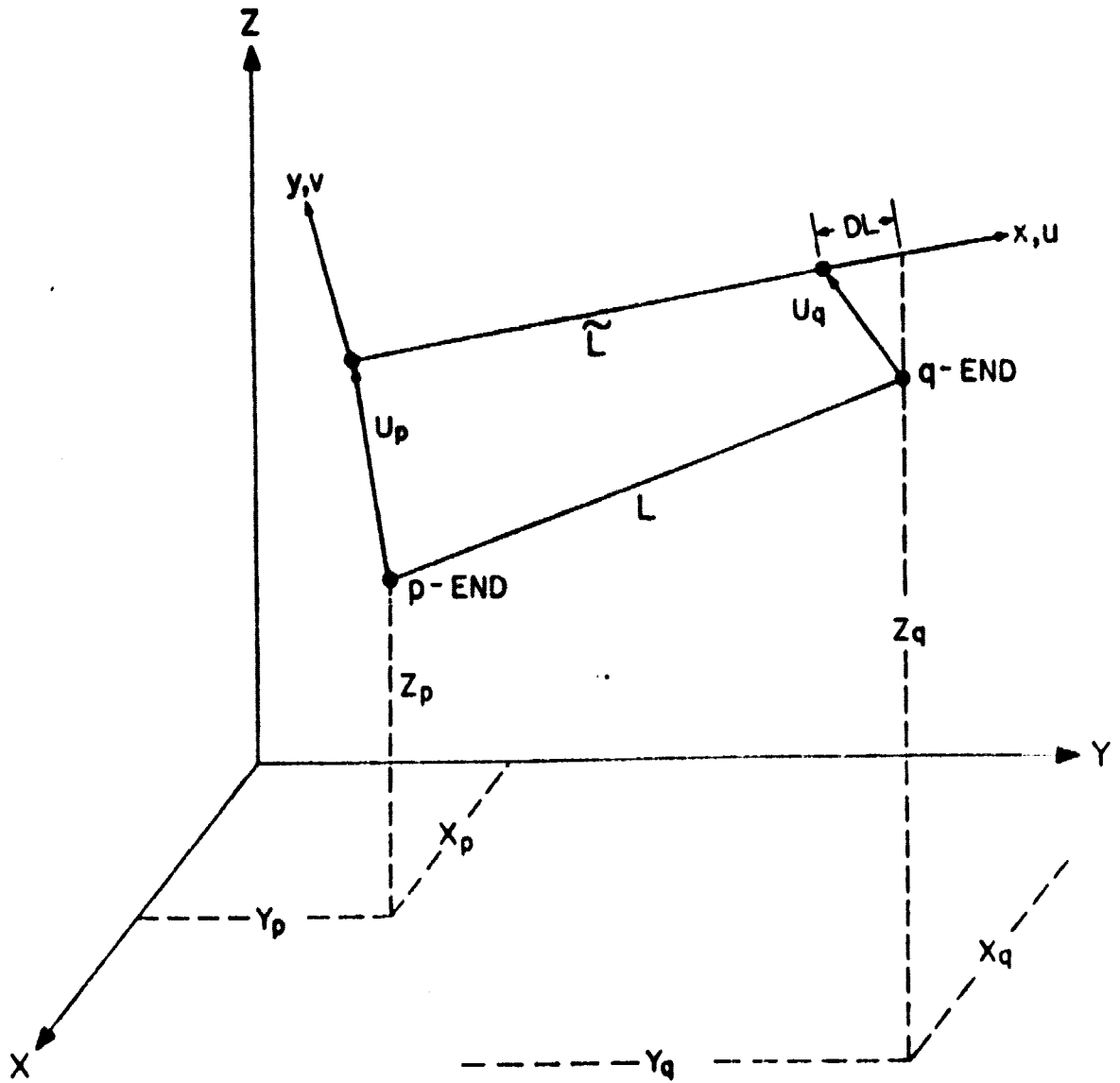

Figure A-1

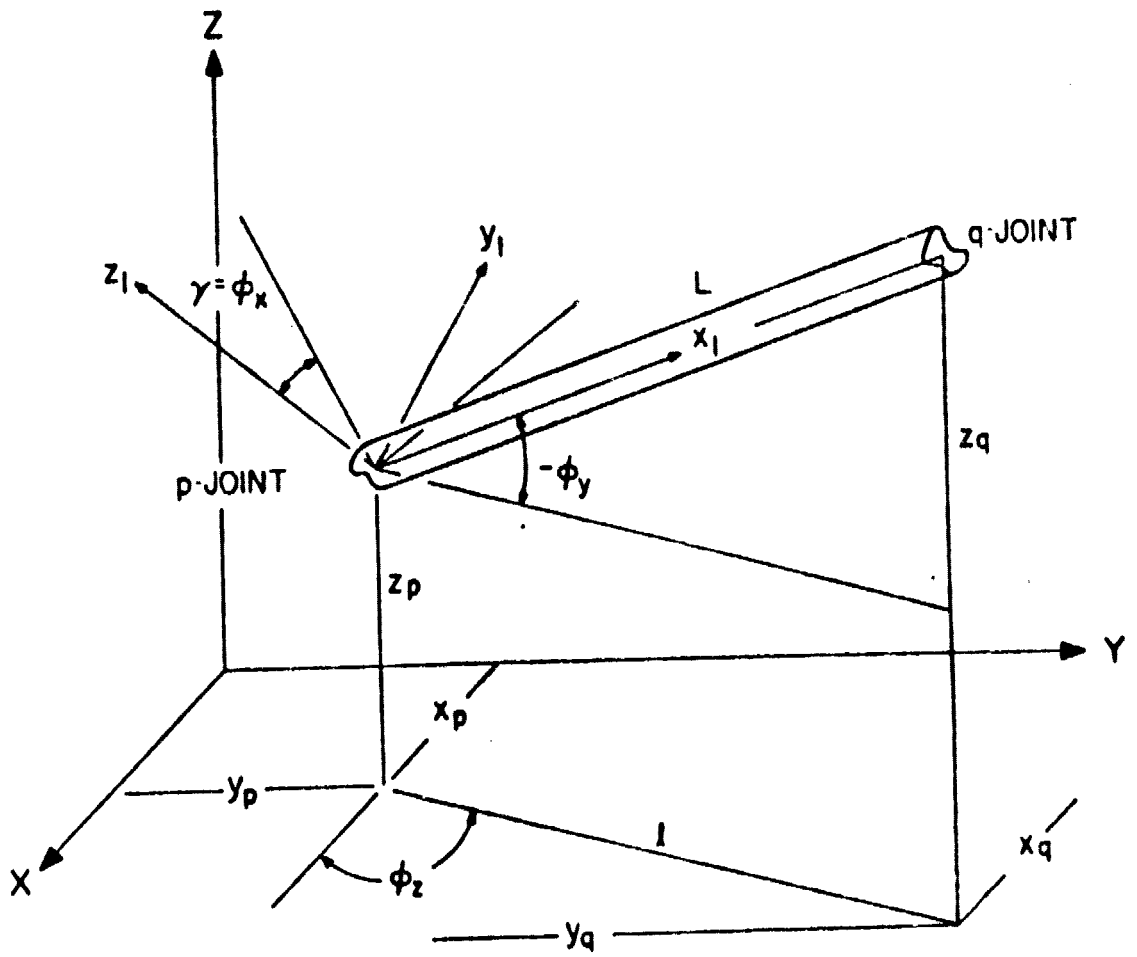

Figure A-2

From Figure (A-3), the displacements of the end q relative to the end p can be seen to be

$$\delta \underline{u} = (\underline{R}_q - \underline{R}_p) - \underline{L} + (\underline{U}_q - \underline{U}_p) \quad (A-5)$$

or in terms of the three components as

$$\begin{Bmatrix} \delta u \\ \delta v \\ \delta w \end{Bmatrix} = [T]_p \begin{Bmatrix} X_q - X_p \\ Y_q - Y_p \\ Z_q - Z_p \end{Bmatrix} - \begin{Bmatrix} L \\ 0 \\ 0 \end{Bmatrix} + [T]_p \begin{Bmatrix} U_q - U_p \\ V_q - V_p \\ W_q - W_p \end{Bmatrix} \quad (A-6)$$

where again U_i , V_i and W_i ($i=p$ or q) denote the global displacements of the nodes. The matrix $[T]_p$ can be shown to be [9]

$$[T]_p = [T_1(\phi_x, \phi_y, \phi_z)][T_1(\theta_{xp}, \theta_{yp}, \theta_{zp})] \quad (A-7)$$

with

$$[T_1(\alpha_x, \alpha_y, \alpha_z)] = \begin{bmatrix} c_y c_z & c_y s_z & -s_y \\ -c_x s_z + s_x s_y c_z & c_x c_z + s_x s_y s_z & s_x c_y \\ s_x s_z + c_x s_y c_z & -s_x c_z + c_x s_y s_z & c_x c_y \end{bmatrix} \quad (A-8)$$

$c_i = \cos \alpha_i$ and $s_i = \sin \alpha_i$ for $i=x, y$ and z . Angles ϕ_x , ϕ_y and ϕ_z are the initial orientation angles described in Figure (A-2) and angles θ_{xp} , θ_{yp} and θ_{zp} are the rigid body rotations of the end p. In deriving Eq. (A-7) Euler angle transformations are implied with the order of the rotations being α_z , α_y and α_x .

Similarly, with the restriction of small relative rotations within the element, the rotations ψ_x , ψ_y and ψ_z of the end q relative to the end p are

$$\begin{Bmatrix} \psi_x \\ \psi_y \\ \psi_z \end{Bmatrix} = [T]_p \begin{Bmatrix} \theta_{xq} - \theta_{xp} \\ \theta_{yq} - \theta_{yp} \\ \theta_{zq} - \theta_{zp} \end{Bmatrix} \quad (A-9)$$

With the relative generalized displacements $\{\delta u, \delta v, \delta w\}$ and $\{\psi_x, \psi_y, \psi_z\}$ known the usual deformation patterns of the reference axis of the beam element in the co-rotational co-ordinate system are assumed

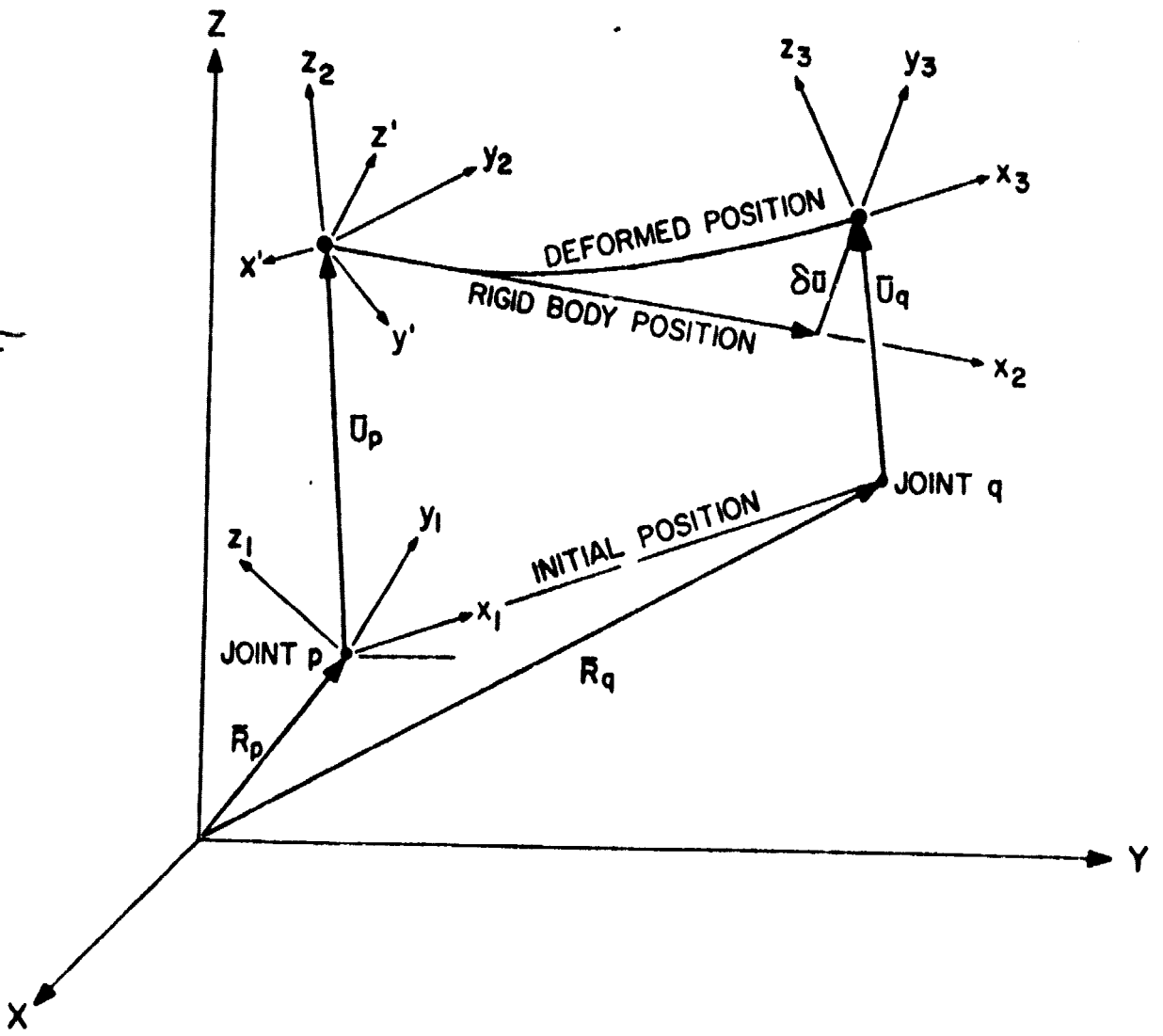

Figure A-3

to be

$$\left. \begin{aligned}
 u(\xi) &= \xi \frac{\delta u}{L} \\
 v(\xi) &= \frac{1}{L} (3\xi^2 - 2\xi^3)(\delta v - z_s \psi_x) + (\xi^3 - \xi^2)\psi_z \\
 w(\xi) &= \frac{1}{L} (3\xi^2 - 2\xi^3)(\delta w + y_s \psi_x) - (\xi^3 - \xi^2)\psi_y \\
 \beta &= \xi \psi_x
 \end{aligned} \right\} \quad (A-10)$$

where $\xi = x/L$ and y_s and z_s are the co-ordinates of the shear center of the cross-section of the beam. The strain of the reference axis can then be shown to be

$$\begin{aligned}
 \epsilon &= \xi \frac{\delta u}{L} - \eta \left[\frac{6}{L} (1-2\xi)(\delta v - z_s \psi_x) + 2(3\xi-1)\psi_z \right] \\
 &\quad - \zeta \left[\frac{6}{L} (1-2\xi)(\delta w + y_s \psi_x) - 2(3\xi-1)\psi_y \right]
 \end{aligned} \quad (A-11)$$

with $\eta = y/L$ and $\zeta = z/L$. In the above equations it is implicitly assumed that the lateral displacements and twists are referenced to a longitudinal axis through the shear center while the axial displacements and rotations are referenced to the centroidal axis. As shown in reference [23] this assumption necessitates the introduction of an additional degree of freedom in the axial direction in the interest of equilibrium satisfaction in the inelastic range.

(iii) Membrane Element

The membrane element of Figure (A-4) is a plane triangular thin plate element under constant strain. The element can undergo large rigid body motions but its deformation is restricted to only in-plane stretching resulting from finite displacements of its vertices.

The orientation of the element is uniquely determined by the global co-ordinates of its three vertices, p° , q° and r° . The relative displacements δu_q , δu_r and δv_r defined in Figure (A-4) can be seen to be

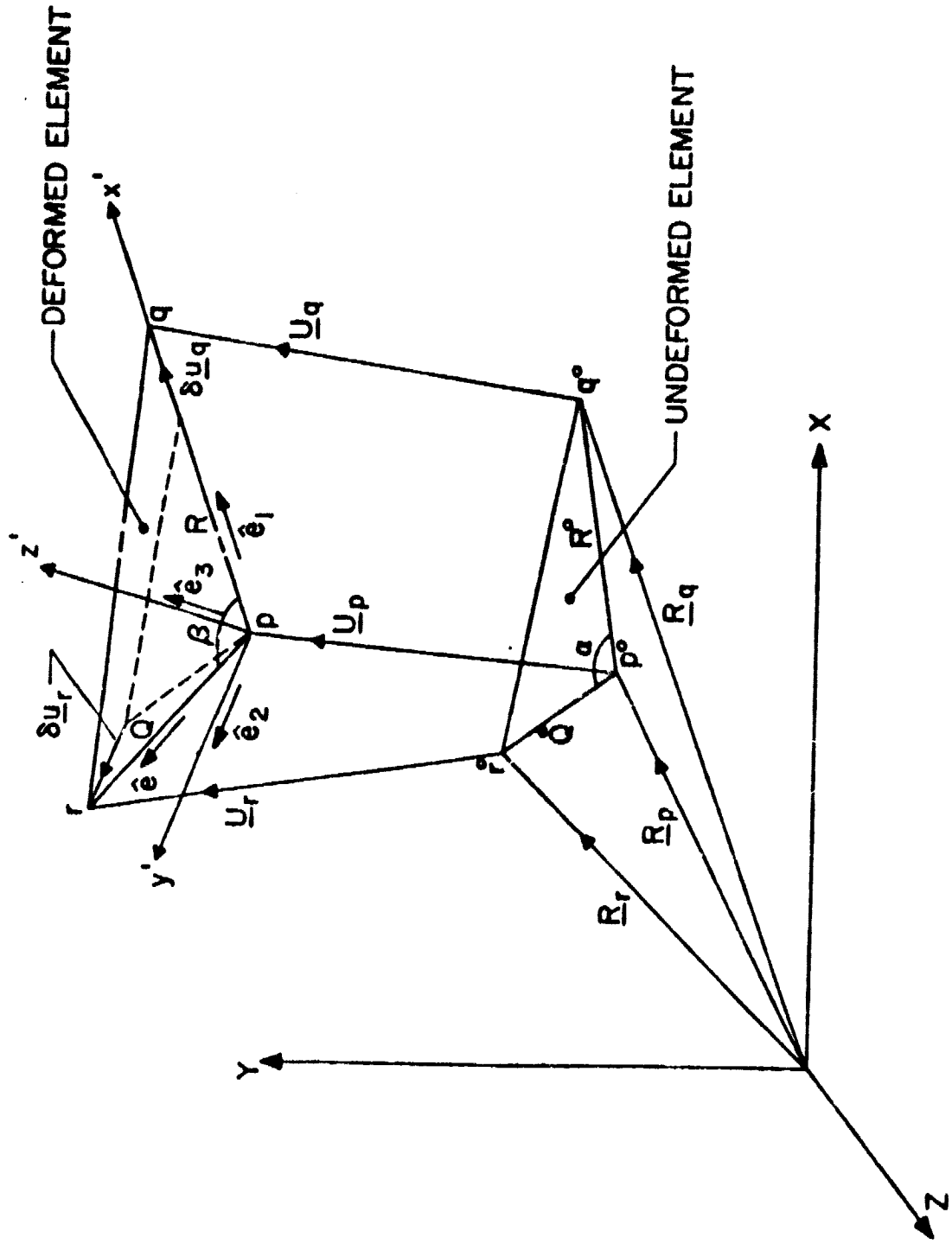

Figure A-4

$$\begin{aligned}
\delta u_q &= R - R^0 \\
\delta u_r &= Q \cos \beta - Q^0 \cos \alpha \\
\delta u_r &= Q \sin \beta - Q^0 \sin \alpha
\end{aligned}
\tag{A-12}$$

with

$$\begin{aligned}
R^0 &= (X_{rp}^2 + Y_{rp}^2 + Z_{rp}^2)^{1/2} \\
R &= [(X_{rp} + U_{rp})^2 + (Y_{rp} + V_{rp})^2 + (Z_{rp} + W_{rp})^2]^{1/2} \\
Q^0 &= (X_{qp}^2 + Y_{qp}^2 + Z_{qp}^2)^{1/2} \\
Q &= [(X_{qp} + U_{qp})^2 + (Y_{qp} + V_{qp})^2 + (Z_{qp} + W_{qp})^2]^{1/2} \\
\cos \alpha &= (X_{qp} X_{rp} + Y_{qp} Y_{rp} + Z_{qp} Z_{rp}) / (Q^0 R^0) \\
\cos \beta &= [(X_{rp} + U_{rp})(X_{qp} + U_{qp}) + (Y_{rp} + V_{rp})(Y_{qp} + V_{qp}) + \\
&\quad (Z_{rp} + W_{rp})(Z_{qp} + W_{qp})] / (QR)
\end{aligned}
\tag{A-13}$$

and typically $\alpha_{ij} = \alpha_i - \alpha_j$. Next, as in the case of the two previous elements, deformation patterns $u(x,y)$ and $v(x,y)$ in the co-rotational co-ordinate system when expressed in terms of the local nodal displacements yield

$$\left.
\begin{aligned}
u(x,y) &= u_p + \left(\frac{\delta u_q}{R^0} \right) x + \left[\frac{\delta u_r}{Q^0 \sin \alpha} - \frac{\delta u_q}{R^0} \cot \alpha \right] y \\
v(x,y) &= v_p + \left(\frac{\delta v_q}{R^0} \right) x + \left[\frac{\delta v_r}{Q^0 \sin \alpha} - \frac{\delta v_q}{R^0} \cot \alpha \right] y
\end{aligned}
\right\}
\tag{A-14}$$

with the strains ϵ_{xx} , ϵ_{yy} and γ_{xy} determined on the basis of the small deformation theory as

$$\left.
\begin{aligned}
\epsilon_{xx} &= \frac{\partial u}{\partial x} = \left(\frac{\delta u_q}{R^0} \right) \\
\epsilon_{yy} &= \frac{\partial v}{\partial y} = \frac{\delta v_r}{Q^0 \sin \alpha} \\
\gamma_{xy} &= \frac{\partial u}{\partial y} + \frac{\partial v}{\partial x} = \left(\frac{\delta u_r}{Q^0 \sin \alpha} - \frac{\delta u_q}{R^0} \cot \alpha \right)
\end{aligned}
\right\}
\tag{A-15}$$

Thus, with the assumption that the total deformation theory of plasticity is applicable, the effective strain and effective stress defined by Eqs. (6-b) and (6-c) yield estimates of the stresses and strain energy densities from the material model. It is obvious that the integrations over the volume of the element are rendered trivial by virtue of the assumption that strains and hence the stresses and strain energy densities within the element are constant.

(iv) Rigid Link

Rigid link is an element which merely translates and rotates without any appreciable deformations. The element is identified by two nodes located with reference to the global co-ordinate system. One of these two nodes is referred to as the master or primary node, p, with a maximum of six independent degrees of freedom. The motions of the slave or secondary node or nodes, q, are determined purely from kinematics by setting the left hand side of equation (A-5) to zero. Knowing the dependent displacements of the secondary nodes,

$$\{U\}_q = \{U\}_p + [T]_p^T \{L\} + \{R\}_p - \{R\}_q \quad (A-16)$$

the contribution, to the total potential energy, of loads applied directly at the secondary nodes can thus be determined.

Figure Legend

<u>Figure No.</u>	<u>Title</u>
1	Finite Element Model of an Aircraft Fuselage
2	A Model for Strain Energy Integration
3	Effective Stress Versus Effective Strain
4	The Rod-Spring Problem
5	Snap-Through of a Shallow Arch
6	Post-Buckling Elastic-Plastic Response of a Thin-Walled Column
7	Impulsively Loaded Clamped Beam
8	The Notch Problem
A-1	Deformation of a Truss Element
A-2	Frame Element Orientation
A-3	Deformation of a Frame Element
A-4	Deformation of a Membrane Element