

General Disclaimer

One or more of the Following Statements may affect this Document

- This document has been reproduced from the best copy furnished by the organizational source. It is being released in the interest of making available as much information as possible.
- This document may contain data, which exceeds the sheet parameters. It was furnished in this condition by the organizational source and is the best copy available.
- This document may contain tone-on-tone or color graphs, charts and/or pictures, which have been reproduced in black and white.
- This document is paginated as submitted by the original source.
- Portions of this document are not fully legible due to the historical nature of some of the material. However, it is the best reproduction available from the original submission.



Technical Memorandum 80265

(NASA-TM-80265) SOURCES OF THE STRONGEST RF
RADIATION FROM LIGHTNING (NASA) 22 F HC
A02/MF A01 CSCI 04A

N79-23559

Unclas
G3/46 25919

Sources of the Strongest RF Radiation from Lightning

D. M. Le Vine

APRIL 1979

National Aeronautics and
Space Administration

Goddard Space Flight Center
Greenbelt, Maryland 20771

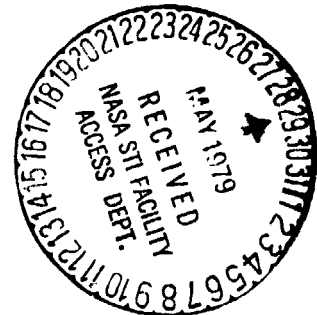

TM 80265

SOURCES OF THE STRONGEST RF RADIATION FROM LIGHTNING

David M. Le Vine

Microwave Sensor Branch

April 1979

GODDARD SPACE FLIGHT CENTER

Greenbelt, Maryland 20771

SOURCES OF THE STRONGEST RF RADIATION FROM LIGHTNING

David M. Le Vine

Microwave Sensor Branch

Goddard Space Flight Center

Greenbelt, Maryland 20771

ABSTRACT

Experiments performed at the Kennedy Space Center, Florida during TRIP-78 have identified sources of the strongest RF radiation from lightning in the HF-VHF frequency range. Measurements were made of electric field changes associated RF radiation using a field change system triggered on the output of an RF detector. The field changes associated with the strongest RF radiation are very fast (10 - 20 μ s), bipolar pulses having an initial negative going half-cycle followed by a positive overshoot. These fast pulses consistently produced more RF radiation than was associated with return strokes, and their shape was remarkably consistent, independent of frequency.

CONTENTS

	<u>Page</u>
ABSTRACT	iii
INTRODUCTION	1
DATA	2
DISCUSSION	6
CONCLUSIONS	8
ACKNOWLEDGMENT	9
REFERENCES	10

ILLUSTRATIONS

<u>Figure</u>		<u>Page</u>
1	Schematic diagram of the experiments performed at Kennedy Space Center during TRIP-78.	12
2	Electric field changes triggered on RF radiation at 139 MHz (vertical polarization).	13
3	Electric field changes triggered on RF radiation at 3 MHz (vertical polarization).	14
4	Electric field changes from a system internally triggered (left) and triggered on large amplitude RF radiation at 139 MHz (right).	15
5	Electric field changes from a system internally triggered (left) and triggered on large amplitude RF radiation at 139 MHz (right).	16
6	Electric field changes from a system internally triggered (left) and triggered on large amplitude RF radiation at 139 MHz (right).	17

SOURCES OF THE STRONGEST RF RADIATION FROM LIGHTNING

INTRODUCTION

Radio frequency radiation from lightning in the HF-VHF range is of interest because promising developments for remote sensing lightning are taking place in this frequency range (Taylor, 1978; Proctor, 1971, 1977; Lhermitte, 1978; Warwick, et al., 1979), and because much remains unknown about radiation from lightning at these frequencies (Pierce, 1977). Recently, RF radiation has been examined from return strokes (Le Vine, and Krider, 1977; Rust, et al., 1979) and also from some cloud processes (Krider, Weidman, and Le Vine, 1978). These recent observations in Florida corroborate earlier observations of return strokes in New Mexico (Brook and Kitagawa, 1964; Takagi, 1969) and together reveal patterns which may be clues to underlying causal mechanisms (e.g., Le Vine, Krider and Weidman, 1979). The subject of the present paper is a series of experiments performed in Florida during TRIP-78 to identify those events which produce the strongest RF radiation. The sources of the strongest RF radiation appear to be cloud processes, not return strokes, and cloud processes of a very characteristic shape. The electric field change associated with them is a very fast (10 – 20 μ s) bipolar pulse with an initial negative half-cycle typically followed by a positive overshoot. (Signs are chosen so that positive is the direction of the fair weather field.) The sign suggests that these pulses belong to the class of large field changes observed by Weidman and Krider (1979) to occur predominantly in intracloud flashes. However, these strong sources of RF radiation are of significantly shorter duration than the field changes they reported.

DATA

All data were collected at the Kennedy Space Center, Florida during the Thunderstorm Research International Project (Pierce, 1976) during the summer, 1978. Two experiments were performed to identify the sources of strong RF radiation and these are illustrated with schematics in Figure 1. Experiment "A" was used to identify the electric field changes associated with the strongest RF radiation, and experiment "B" was used to determine where within the flash these sources occurred.

In experiment A, the signal from a fast electric field change system similar to that used by Le Vine and Krider (1977) was recorded on a Biomation model 8100 waveform recorder (digital sample-and-hold device) and the output was plotted with an X-Y plotter. The waveform recorder was operated with a high sample rate (.05 μ s per sample) in the pre-trigger mode so that signal before and after the trigger pulse was recorded. The biomation was triggered on the gate pulse of an oscilloscope which in turn was triggered on the output from one of several RF detectors. The RF system was similar to that described by Le Vine and Krider (1977) and consisted of several 300 kHz bandwidth channels at frequencies between 3 - 300 MHz. In experiment A, the trigger threshold at the scope was set at a very high level so that only an occasional trigger occurred. It was important that the trigger threshold was set very high. Insufficiently high thresholds resulted in a variety of electric field waveforms, reflecting the general spectrum of large field changes associated with cloud processes (Weidman and Krider, 1979). But with the trigger level high, the electric field changes observed were consistently very fast bipolar pulses.

Several examples of the results of this experiment are shown in Figures 2 and 3. Two examples of the electric field changes triggered on the very strong RF radiation are shown in each figure. Each example in the pair was recorded within several minutes of the other. The field changes in Figure 2 were triggered from vertically polarized radiation at 139 MHz and the examples in Figure 3 were triggered from vertically polarized radiation at 3 MHz. Negative field change is down in both figures and the trigger occurred very near the negative peak in each field change record.

Each waveform in Figures 2-3 consists of an initial negative going pulse followed by a positive going overshoot. Typically, the overshoot was smooth, smaller in amplitude, and of somewhat longer duration than the initial negative pulse. The negative pulse was generally jagged with the field changes of longer duration seeming to have more irregularity. However, the most significant feature of these pulses is their duration. These are very fast field changes, the negative half-cycle lasting only 10 μ s or less. The total duration (positive and negative portions together) of even the longest field changes recorded was on the order of 20 μ s. This is to be compared with the large negative going cloud processes observed by Weidman and Krider (1979) where the mean duration was more than 60 μ s.

This experiment was repeated on several days during July, 1978, using radiation at different frequencies between 3 MHz and 300 MHz to trigger the system. The field changes observed were independent of frequency and were consistently quite similar to those shown in Figures 2 and 3. The maximum signal level reached by these electric field changes was on the order of 1/3 the peak obtained by return strokes recorded at about the same time.

The second experiment (experiment B, Figure 1) was performed to determine where within the flash the field changes associated the large RF radiation originated. In this experiment, two Biomation Model 805 waveform recorders were used to record the electric field changes from a common field change system. One waveform recorder was triggered internally by the electric field itself and consequently monitored large electric field changes regardless of RF produced, while the other was triggered as in experiment A by the RF signal and thus recorded only those field changes associated with strong RF radiation. Sampling was at the rate of 0.5 μ s per sample, and the sampled waveforms were displayed on oscilloscopes and photographed. The threshold for the RF trigger was set high, but not as high as in experiment A, so as to better observe the context in which the strong RF radiation occurred.

Examples of data recorded in this mode are shown in Figures 4 - 6. Two strips of film are shown in each figure. On the left are the electric field changes recorded while triggering internally on the electric field changes themselves, and to the right are the electric field changes recorded by triggering on the large amplitude RF signal (vertically polarized 139 MHz in these examples). In

each figure time advances from bottom to top with approximately 0.8 seconds of data shown. The dashes at the far left are 0.1 second time ticks. Each electric field change (horizontal axis) is one millisecond long and triggering occurred very near the center of the record on both film strips.

A remarkably consistent feature of this data was the absence of strong RF radiation during return strokes. A typical sequence is illustrated in Figure 4. On the left are the fast electric field changes of several return strokes during a cloud-to-ground flash; however, nothing appears on the right where triggering is determined by the RF signal. Thus, during this flash the RF radiation never exceeded the trigger threshold. In fact, in the entire data set of more than 40 cloud-to-ground flashes, a return stroke never produced enough RF radiation to trigger the system. On the other hand, RF radiation exceeding the trigger threshold frequently was produced at other times during the flash. An example is shown in Figure 5 where a cloud-to-ground flash preceded by a cloud discharge is shown. Several events produced RF radiation strong enough to trigger the system on the right during this flash. The RF triggers appear to be grouped, one set occurring early before the return strokes and the other set occurring at the end of the flash. The electric field changes in the early group are labelled, "A" through "D". Two of the RF-triggered field changes in the early group (A and B) are the same as the field changes recorded on the left by the self-triggering system; however, the other two RF triggers in this set apparently did not have large enough field changes to trigger on the left. One of these (C) is a sharp negative pulse just barely visible near the center of the trace. These events are followed by three field changes typical of return strokes, none of which produced RF radiation of sufficient amplitude to trigger on the right. However, several other events produced RF radiation exceeding the trigger threshold during the late phases of this flash. These are the four traces at the top of the right-hand film strip, one of which occurs before the last return stroke and the others later. This example is representative of the data and is particularly interesting because it identifies the strong RF radiation with cloud processes, either before or after the first return stroke, but not with the return strokes themselves. The fast negative pulses seen in Figure 5 to occur before the return stroke were observed both before and after the first return stroke. An

example in which two fast negative pulses (arrow) occur after the first return stroke is shown in Figure 6. (The pulse in the upper trace in Figure 6 was traced to enhance its visibility while on the lower record the pulse was not touched.) Again, notice the absence of RF triggers during the return strokes in this example.

DISCUSSION

During these experiments the RF radiation from return strokes did not exceed the threshold of the RF-triggered electric field change system. However, this is not to say that return strokes do not produce RF radiation. In fact, the evidence definitely identifies return strokes as sources of such radiation (Le Vine and Krider, 1977; Brook and Kitagawa, 1964; Rust et al., 1979). If instead one were to consider sources of RF radiation in the context of all events in the entire flash, and not just look for the strongest producers as has been done here, one would find that return strokes not only produce RF radiation but produce radiation which is quite strong in comparison to most other events in the flash (Le Vine, Krider and Weidman, 1979; Le Vine, 1978). The implication of the two experiments reported here is that certain cloud processes are even stronger producers of RF radiation than return strokes, and that the strongest producer of all is the unusually fast negative pulse described above.

Although the nature of the fast negative pulses is not known, an interesting comparison can be made between them and K-changes. Among the similarities are that K-changes are known to be associated with strong RF radiation, especially at low frequencies (Pierce, 1977), and that the sign of the field change associated with the fast negative pulse is typical of K-changes, especially those occurring in the late stages of a flash (Brook and Ogawa, 1977). However, the 10 - 20 μ s duration of the fast negative pulse is significantly shorter than the 1 ms typical of K-changes, and K-changes typically occur in sequences of several at a time spaced 10 - 30 ms apart. In contrast, the fast negative pulses appeared to be relatively isolated and infrequent in the data collected during TRIP. The difference in duration is not as dramatic as it first appears because the 1 ms duration of the K-changes may in fact only be an upper bound (Brook and Ogawa, 1977). If one assumes this to be the case, then the similarities are great enough to suggest that the RF super pulse is an occasional, very fast K-change.

There are additional arguments to support this hypothesis. In particular, the recoil streamer model generally associated with K-changes (Brook and Ogawa, 1977; Pierce, 1977) also fits the characteristics of the RF super pulses reasonably well with some simple modifications. In the case

of a K-change, the current pulse is presumably triggered when an advancing streamer encounters a localized body of charge, and typical channel lengths are estimated to be on the order of 1 km (Brook and Ogawa, 1977). Assuming the channel to be the same for the RF super pulse, one concludes that the velocity of propagation must be on the order of 10^8 m/s (e.g., 1 km + 10 μ s). This is much faster than the 1 ms duration would predict for K-changes but is not at all unreasonable (e.g., this is typical of return strokes; Uman, 1969). Now assuming that the recoil consists of a current pulse propagating back along the streamer channel, one can compute the associated electric field change (Le Vine and Meneghini, 1978; Pierce, 1977; Uman et al., 1975). Regarding the sign of the field change, one finds that a recoil discharge between an upper positive charge and lower negative charge, as presumably would take place during a cloud discharge, would have the same sign (negative) as the RF super pulse. In contrast, a discharge to a lower positive charge (e.g., the "p"-region) would have the sign of a return stroke carrying negative charge to ground (positive). The shape of the electric field change based on this model is also consistent with data shown in Figure 2-3. For example, assuming that the discharge takes place along a channel with well defined ends, as might be expected for a recoil between localized charge pockets, the model predicts a positive overshoot typical of the data (Le Vine and Meneghini, 1978; Uman et al., 1975).

CONCLUSIONS

The strongest producers of RF radiation during lightning flashes are characterized by very fast negative going electric field changes. These pulses are typically 10 – 20 μ s in duration and generally are associated with a positive overshoot. The radiation produced by these fast negative pulses was consistently stronger than that produced by return strokes.

The available evidence suggests that these pulses are cloud processes and a reasonable case can be made for their being occasional, very fast K-changes. However, more data is needed to confirm this hypothesis.

ACKNOWLEDGMENT

This work would not have been possible without the dedicated support of C. S. Wilson and B. J. Wilson of the Georgia Institute of Technology, especially during long days in Florida, nor without the help of E. P. Krider and C. D. Weidman of the University of Arizona, in piecing together the experiments.

REFERENCES

- Brook, M., and N. Kitagawa (1964), "Radiation from Lightning Discharges in the Frequency Range 400-1000 Mc/s," *J. Geophys. Res.*, 69, pp. 2431-2434.
- Brook, M., and T. Ogawa (1977), "The Cloud Discharge" in Lightning, Vol. 1, Chap. 6, R. H. Golde, Ed., Academic Press.
- Krider, E. P., C. D. Weidman and D. M. Le Vine (1978), "The Temporal Structure of HF and VHF Radiation During Intracloud Lightning Discharges," *Proceedings AMS Conference on Cloud Physics and Atmospheric Electricity*, pp. 588-590, Issaquah, Washington, August.
- Le Vine, D. M. (1978), "The Temporal Structure of RF Radiation from Lightning," *NASA Technical Memorandum TM-78095*.
- Le Vine, D. M., and E. P. Krider (1977), "The Temporal Structure of HF and VHF Radiations During Florida Lightning Return Strokes," *Geophys. Res. Lett.*, pp. 13-16.
- Le Vine, D. M., E. P. Krider, and C. D. Weidman (1979), "VHF Radiation Produced by Intracloud Lightning Discharges," *NASA Technical Paper TP-1454*.
- Le Vine, D. M., and R. Meneghini (1978), "Simulation of Radiation From Lightning Return Strokes: The Effects of Tortuosity," *Radio Sci.*, Vol. 13 (5), pp. 801-809.
- Lhermitte, R. M. (1978), "Doppler Radar and Electrical Radiation Observations of Thunderstorms," *Proceedings, AMS Conf. on Cloud Physics and Atmospheric Electricity*, Seattle, August.
- Pierce, E. T. (1977), "Atmospherics and Radio Noise," in Lightning Vol. 1, Chap. 10, R. H. Golde, Ed., Academic Press.
- Pierce, E. T. (1976), "The Thunderstorm Research International Program (TRIP) - 1976," *Bull. Amer. Meteor. Soc.*, Vol. 57, pp. 1214-1216.
- Proctor, D. E. (1971), "A Hyperbolic System for Obtaining VHF Radio Pictures of Lightning," *J. Geophys. Res.*, Vol. 76, pp. 1478-1489.
- Proctor, D. E. (1977), "VHF Radio Pictures of Lightning," Electrical Processes in Atmospheres, Ed. by H. Dolezalek and R. Reiter, Dr. Dietrick Steinkopff Verlag, Darmstadt, 865 pp.

- Rust, W. D., P. R. Krehbiel, and A. Shlanta (1979), "Measurements of Radiation from Lightning at 2200MHz," submitted to Geophys. Res. Lettrs.
- Takagi, M. (1969), "VHF Radiation from Ground Discharges," Proc. Res. Inst. Atmospheric, Nagoya University, Japan, pp. 163-1968.
- Taylor, W. L. (1978), "A VHF Technique for Space-Time Mapping of Lightning Discharges," J. Geophys. Res., Vol. 83 (7), pp. 3575-3583.
- Warwick, J. W., C. O. Hayenga and J. W. Brosnahan (1979), "Interferometric Positions of Lightning Sources at 34 MHz," Submitted to J. Geophys. Res.
- Weidman, C. D., and E. P. Krider (1979), "The Waveforms of Radiation Fields Produced by Intra-cloud Lightning Discharges," To be published in J. Geophys. Res.
- Uman, M. A. (1969), Lightning, McGraw-Hill.

EXPERIMENT A

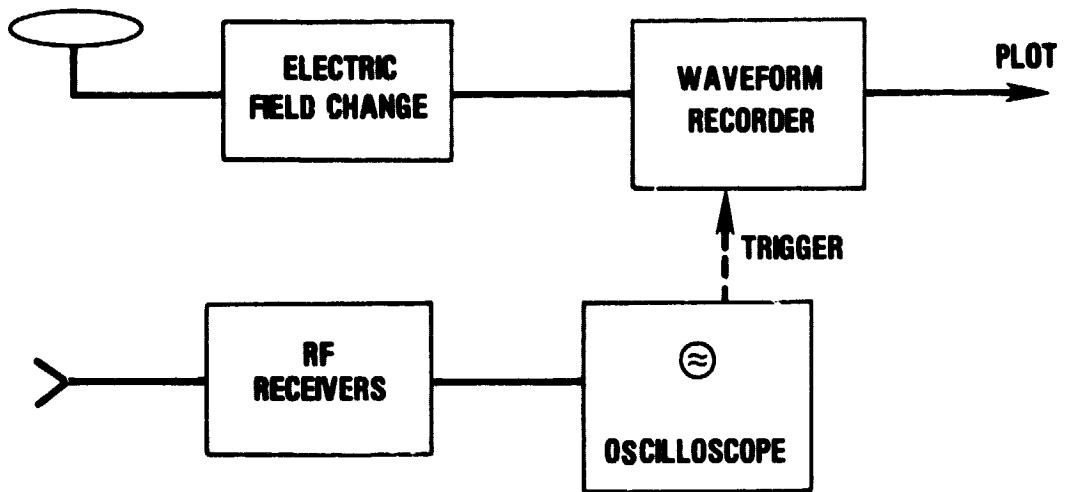

EXPERIMENT B

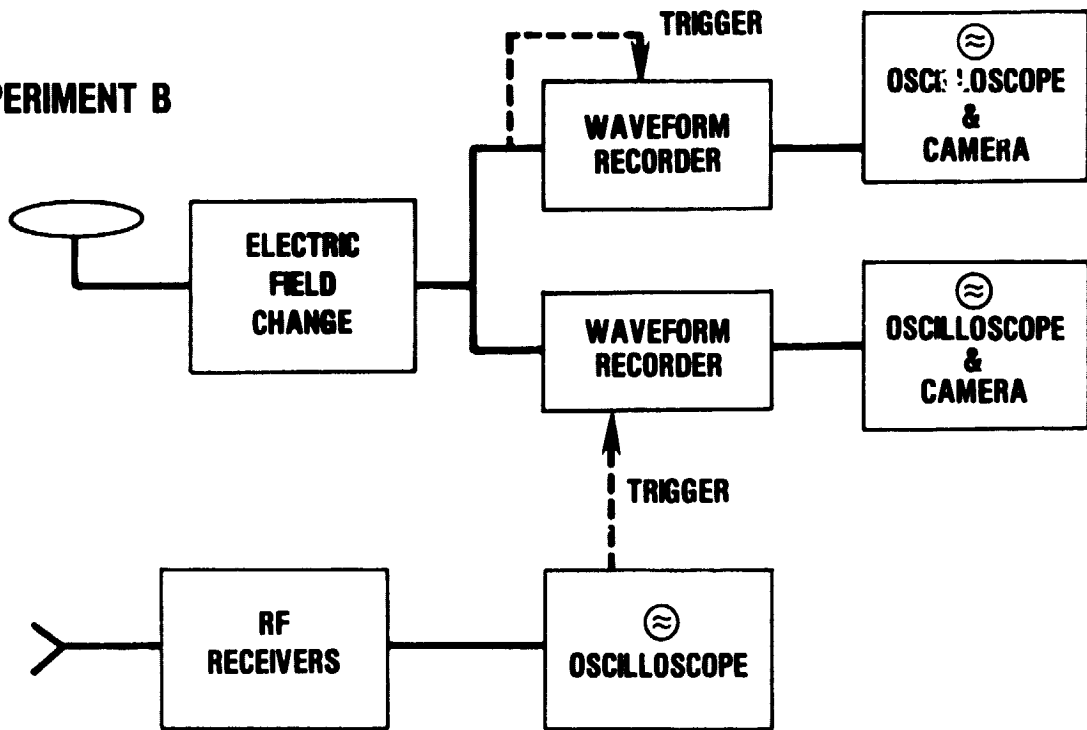

Figure 1. Schematic diagram of the experiments performed at Kennedy Space Center during TRIP-78.

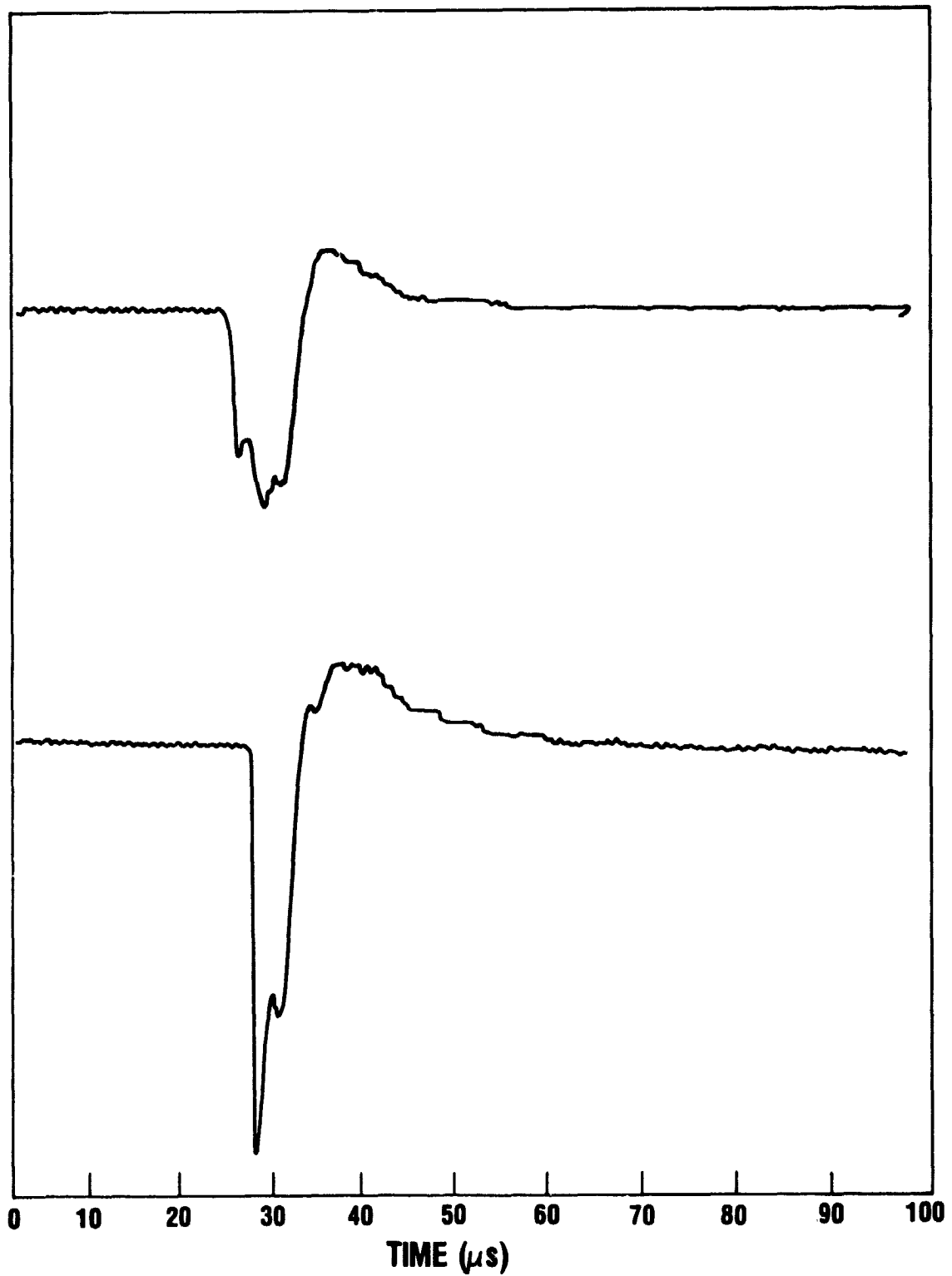

Figure 2. Electric field changes triggered on RF radiation at 139 MHz (vertical polarization). The vertical scale is linear in V/m and the direction of negative field change is down.

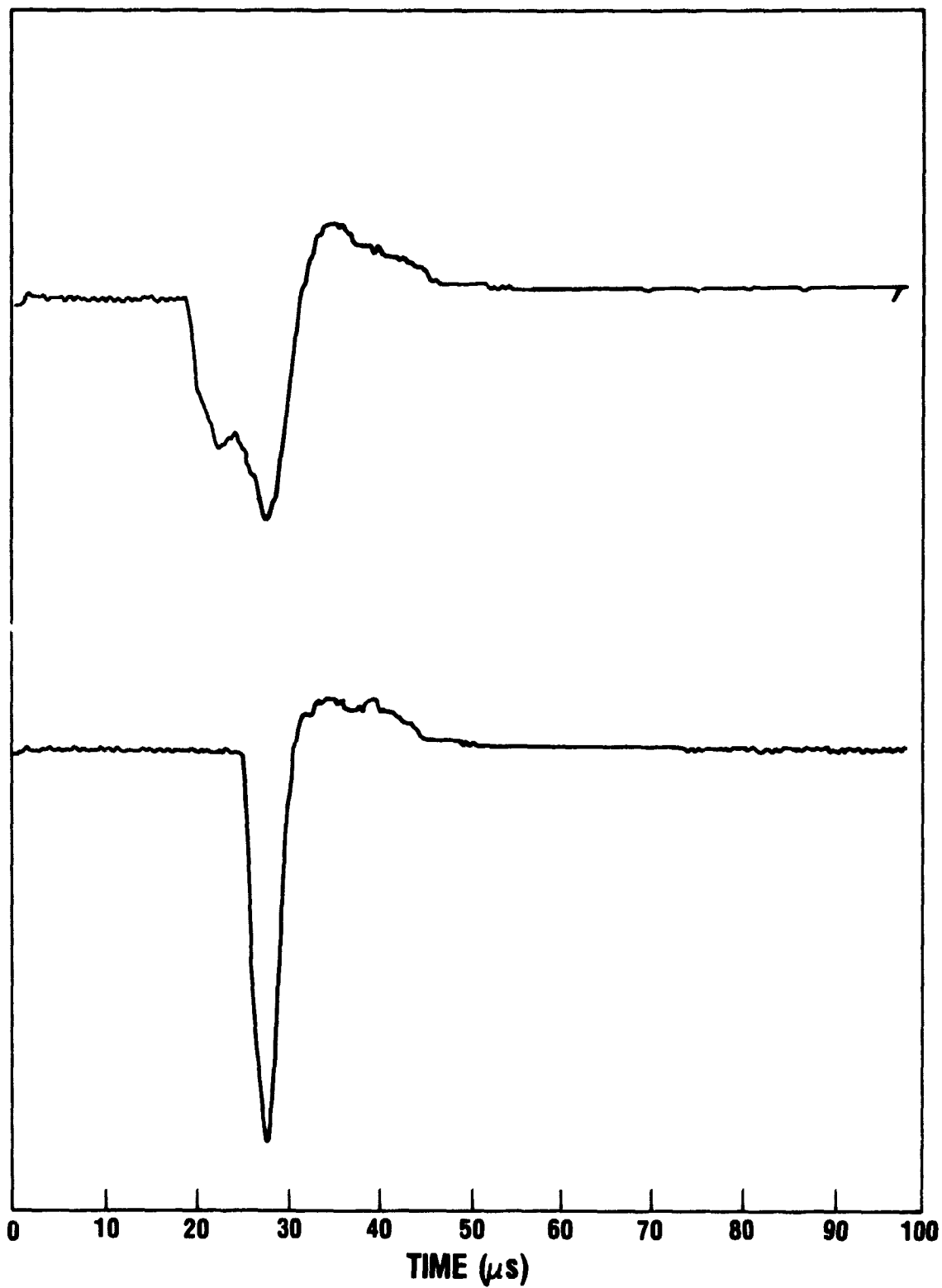

Figure 3. Electric field changes triggered on RF radiation at 3 MHz (vertical polarization).
The vertical scale is linear in V/m and the direction of negative field change is down.

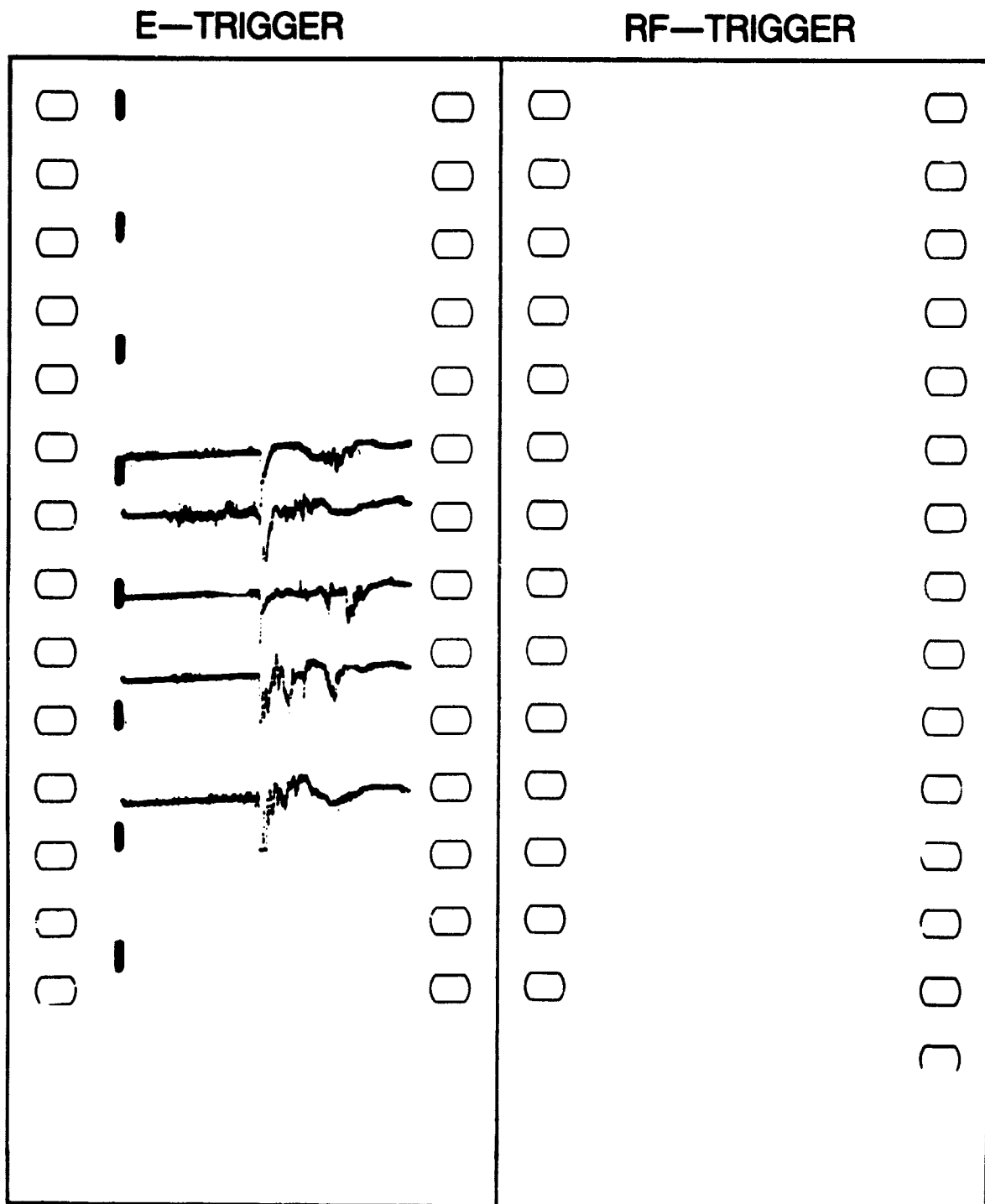

Figure 4. Electric field changes from a system internally triggered (left) and triggered on large amplitude RF radiation at 139 MHz (right). The time ticks on the vertical scale are 0.1 seconds apart and time increases from bottom to top. The duration of each horizontal record is 1 ms. Negative electric field change is up.

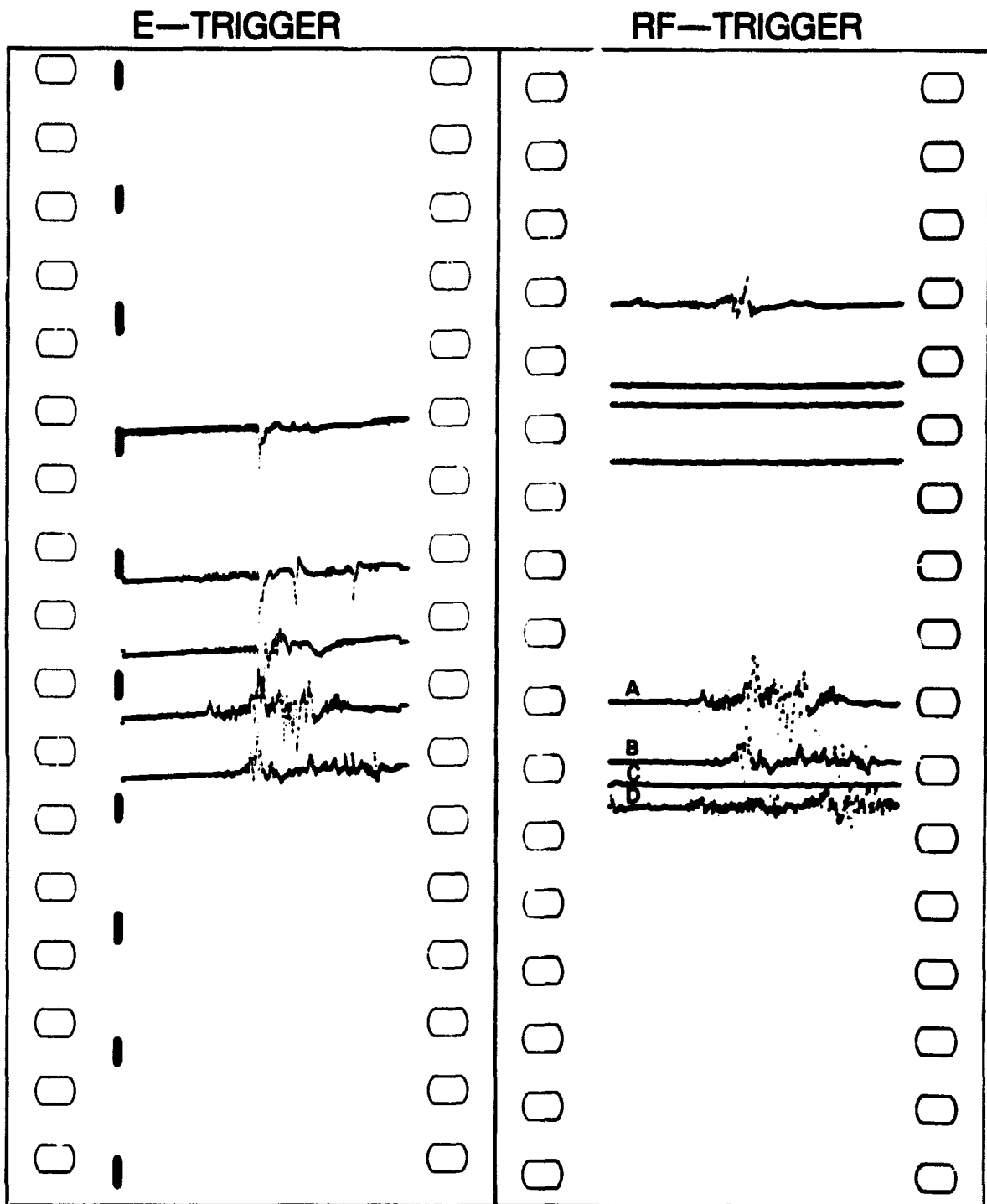

Figure 5. Electric field changes from a system internally triggered (left) and triggered on large amplitude RF radiation at 139 MHz (right). The time ticks on the vertical scale are 0.1 seconds apart and time increases from bottom to top. The duration of each horizontal record is 1 ms. Negative electric field change is up.

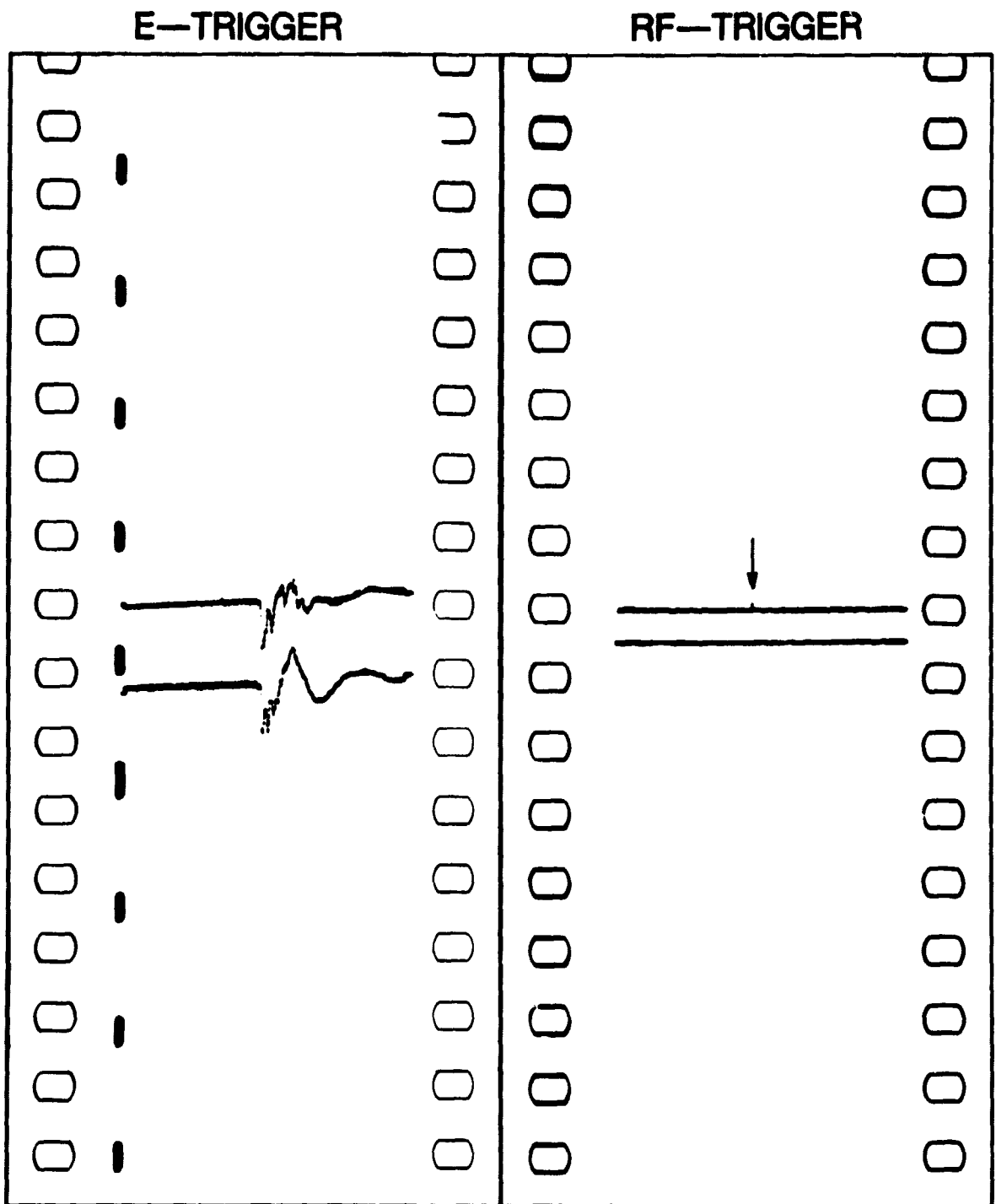

Figure 6. Electric field changes from a system internally triggered (left) and triggered on large amplitude RF radiation at 139 MHz (right). The time ticks on the vertical scale are 0.1 seconds apart and time increases from bottom to top. The duration of each horizontal record is 1 ms and negative electric field change is up. The arrow indicates locations of a fast negative pulse.