

NASA TECHNICAL MEMORANDUM

NASA TM-75624

CIRCUIT FOR CONNECTING THE "VIDEOTON-340"
WITH THE ES-1030 AS AN OPERATOR CONSOLE

V.A. Uskov and G.V. Pryadin

Translation of "Opisaniye skhem vklyucheniya tekstovogo displeya "Videoton-340" v sostav ES-1030 v kachestve konsoli operatora," Academy of Sciences USSR, Institute of Space Research, Moscow, Report Pr-405, 1978, pp. 1-9 + 12 figures.

(NASA-TM-75624) CIRCUIT FOR CONNECTING THE
VIDEOTON-340 WITH THE ES-1030 AS AN OPERATOR
CONSOLE (National Aeronautics and Space
Administration) 16 p HC A02/MF A01 CSCL 09B

N79-23673

Unclas

G3/60 20933



NATIONAL AERONAUTICS AND SPACE ADMINISTRATION
WASHINGTON, D.C. 20546 MAY 1979

NOIRALBAST LINCINN

1. Report No. NASA TM-75624	2. Government Accession No.	3. Recipient's Catalog No.	
4. Title and Subtitle CIRCUIT FOR CONNECTING THE "VIDEOTON-340" WITH THE ES-1030 AS AN OPERATOR CONSOLE		5. Report Date May 1979	
		6. Performing Organization Code	
7. Author(s) V.A. Uskov and G.V. Pryadin, Academy of Sciences USSR, Institute of Space Research; Moscow		8. Performing Organization Report No.	
		10. Work Unit No.	
9. Performing Organization Name and Address Leo Kanner Associates Redwood City, California 94063		11. Contract or Grant No. NASw-3199	
		13. Type of Report and Period Covered Translation	
12. Sponsoring Agency Name and Address National Aeronautics and Space Adminis- tration, Washington, D.C. 20546		14. Sponsoring Agency Code	
		15. Supplementary Notes Translation of of "Opisaniye skhem-vklyucheniya tekstovogo displeya "Videoton-340" v sostav ES-1030 v kachestve konsoli operatora," Academy of Sciences USSR, Institute of Space Research, Moscow, Report Pr-405, 1978, pp. 1-9 + 12 figures.	
16. Abstract A system of connection of the Videoton-340 text display to the standard ES-7070 unit, for use as an operator console, partially replacing and supplementing the ES-7070 electric typewriter, is described. The interactions, including the specific instructions, among the Videoton-340, the Consul-260.1 electric typewriter and the ES-7070, which is the means of user access to the unified system of computers, are presented. Users at the Institute of Space Research note the reliability, high information output rate, noiselessness and convenience of the keyboard of the system.			
17. Key Words (Selected by Author(s))		18. Distribution Statement Unclassified-Umlimited	
19. Security Classif. (of this report) unclassified	20. Security Classif. (of this page) Unclassified	21. No. of Pages	22. Price

Annotation

The system of connection of the Videoton-340 text display, as a component of the standard ES-7070 unit, for use as an operator console is described in this work.

CIRCUIT FOR CONNECTING THE "VIDEOTON-340" ^v
WITH THE ES-1030 AS AN OPERATOR CONSOLE

V.A. Uskov and G.V. Pryadin
Academy of Sciences USSR, Institute
of Space Research, Moscow

Introduction

At the present time in our country a substantial portion of /3*
the entire computer stock is a unified system of computers. These
computers have quite powerful equipment and mathematical support,
they are compatible with each other at various levels, and they
have approximately the same nomenclature for the peripherals.
This work is devoted to the question of modification of one of
these units.

In the unified system of computers, operator communication
with the computation system (VS) is accomplished by means of the
ES-7077 unit (or the ES-7070 in old model computers), with the
Consul-260.1 electric typewriter, a component of the ES-7077
or ES-7070. This electric typewriter has, in our opinion, the
following deficiencies:

low data output rate for an interactive device (which
the ES-7070 and ES-7077 units essentially are);

high noise level during operation;

unjustified high paper consumption since, in the over-
whelming majority of cases, the work of the operator or
programmer at the console does not need documentation.

Therefore, it was decided to replace the Consul-260.1
electric typewriter in the ES-7070 of our ES-1030 computer, with
the Videoton-340 text display, which differs advantageously from
the Consul-260.1 electric typewriter by the following advantages:

1. higher speed (for example, in the online mode, the /4
data output rate on the Videoton-340 is up to 1000 symbols
per second and, on the Consul-260.1 electric typewriter,
up to 10 symbols per second);

* Numbers in the margin indicate pagination in the foreign text.

2. noiseless operation;
3. an order of magnitude higher reliability;
4. great savings, due to the reduction in consumption of paper and typewriter ribbon and the number of routine operations.

At the same time, a shortcoming of the Videoton-340 text display is the impossibility of obtaining hard copy of the information of interest to the user, without auxiliary equipment, (ATsPU3403A, 3403B and the corresponding TEZ", which come separately and are rather in short supply and expensive); Therefore, it was decided to develop a unit, which would make it possible to use the favorable qualities of both the Consul-260.1 electric typewriter and the Videoton-340 text display, and to do this with minimum changes to the ES-7070 unit. For this purpose, the following supplementary circuits were incorporated in the ES-7070 unit:

1. ISO→KOI-7 code converter;
2. code KOI-7 to code GOST 13052-67 converter; as applied to the ES-7077 unit;
3. control units to manage the operation of the Videoton-340 text display;
4. logic disjunction circuits to combine the information and control inputs and outputs of the Consul-260.1 electric typewriter and the Videoton-340.

These circuits make it possible for the user, during work on the computer, to select the device she requires himself (Consul-260.1 electric typewriter or Videoton-340). As needed, the user can edit and input information he requires to the electric typewriter.

The supplementary circuits occupied one standard TEZ" board. 15
The changes concerned only the external wiring of the ES-7070 device.

The following microcircuits were used as the unit base:
ILB552, ILB554, K2GF182 and ILR553.

Description of Circuits

A structural diagram of the ES-7070 unit is presented in Fig. 1. It is seen from it that the Consul-260.1 electric typewriter is two independent units (keyboard and the printer itself), joined by control unit YY. The YY includes a number of blocks, which provide communication of the ES-7070 unit with the channel, recoding of the transmitted and received symbols, analysis and monitoring of the information received, and management of the printout process. It is advisable to use this YY to manage the operation of the Videoton-340 text display, for example, in the "Read" mode.

We examine the operation of the ES-7070 YY. The incoming information is processed under control of cycle counter CTs-1. In the "Read" mode, cycle counter CTs-1 is started by a "signal contact" pulse, which is generated by pressing any key of the Consul-260.1 electric typewriter keyboard. There is a similar signal at the Videoton-340 text display output. This is the "Stgv0" output information tracking signal (see Videoton-340 description, Vol. I-II, Fig. 6.8, Section 6.5.3), which is generated in the "On line-Read" and "Send" modes. Thus, the "Stgv0" signal can be used to start the STs-1. A "Start STs-1" signal shaping circuit was incorporated for this purpose (see Fig. 2). By means of it, cycle counter STs-1 is started by the signal "-signal contact \wedge Read \vee "Stgv0" \wedge Read" signal. Information outputs "Od0.. /6 ...7" of the Videoton-340 text display are combined with PrPM¹ outputs (i.e., of the Consul-260.1 electric typewriter keyboard), by means of disjunction circuits (see Fig. 3), and they sent to the coder ShI input. To overcome the code incompatibility between the Consul-260.1 electric typewriter and the Videoton-340 display (see Appendix 1.2), a "three digit shaping circuit" was incorporated. This auxiliary digit (see Fig. 4), during operation of the display in the "on line-Read" mode, is transmitted to the ISO \rightarrow EVSDIS code converter, bypassing coder ShI. The logic of operation of these blocks is clear from the diagrams presented, and they do not need detailed description.

¹ [PrPM - - typewriter print]

In order to record a symbol generated at a given moment in the Videoton-340 display memory (i.e., to obtain its image on the screen), information signals "Id0...7" and information tracking signal "StgvI" must be sent to the Videoton-340 input (see Videoton-340 description, Vol. I-II, Fig. 6.8, Section 6.5.3). Signals to code buses Id0...7 are transmitted from the output of the EVSdIS-ISO code converter (see Fig. 1) to the Videoton-340 input. Complete code compatibility is achieved, by means of simple switching of the old digits. The "StgvI" signal is generated, by means of the "StgvI" signal shaping circuit (see Fig. 5). The signal "+imp, print" is used in this circuit. It is generated by cycle counter STs-1. Line delay LZ1 is a K2GF182 univibrator, and it is intended to shape the duration of the "StgvI" signal. It must be noted that, during operation of the display in the "on line-Read" mode, the "7 impulse print" signal only reaches the "StgvI" signal shaping circuit input, and its passage to the internal control circuits of the ES-7070 unit is blocked by the "inhibit+impulse print circuit" (see Fig. 5). The "Vkl.Gg" signal is inhibited in a similar manner (see Fig. 6). The use of the ES-7070 /7 control circuit to drive the text display control signals became possible, because the rate of exchange between the console and electric typewriter in the "Read" mode is limited by the speed of the operator at the keyboard, and is not over 3-5 symbols per second, which does not exceed the high speed of the cycle counter STs-1. It was decided to incorporate exchange at the maximum possible rate for the display in the "Write" mode. For this, a "start cycle inhibition circuit" was incorporated (see Fig. 7). In this circuit, the signal "On line ^Write^ Operate" inhibits passage of the infA1 infK signal to the STs-1 input; thereby blocking counter operation. Control of the exchange is transmitted by the following circuits: "TrbA signal generation circuit" (see Fig. 8); "StgvI signal generation circuit."

Return to the channel in the "Write" mode, with the requirements for output of the next symbol, is carried out by means of the "TrbA" signal. The "dMdI" signal, which gives notice of readiness

of the display to record the next symbol in its memory, participates in shaping this signal (see Videoton-340 technical description, Vol. I-II, Fig. 6.8, Section 6.5.3). The maximum possible exchange rate for the display was achieved by these. The exchange continues until the KRK trigger is released, i.e., until complete output of the information in a given message. The transmitted symbols are stored in the Videoton-340 memory in the "On line-Write" mode, at the "StgvI" signal (see Fig. 5). The RgPM is dumped, by means of the "dump RgPM signal shaping circuit." In this circuit, line delay LZ2 is a K2GF182 univibrator, and it is the time shaper (see Fig. 9).

For convenience of visual perception of transmitted messages, a "line feed" signal shaping circuit was incorporated (see Fig. 10). We examine the operation of this circuit in greater detail. During the normal course of operations, exchange between the channel and the console is completed by the "stop upon KT" signal. The TgVK and TgPS triggers are set by this signal. By using the VK signal, the "line feed" signal shaping circuit transmits the "line feed" operation code to the display input. In order to avoid mechanical movement of the Consul-260.1 electric typewriter carriage, a "dump TgVK by means of TgZVK" circuit is incorporated (see Fig. 11). Thus, during operation of the Videoton-340 text display, operation of the Consul-260.1 electric typewriter is completely blocked. /8

Hard copy of the required text is obtained in the "Send" mode. To manage the joint operation of the Consul-260.1 electric typewriter and the Videoton-340 display in the "Send" mode, a "dump dMd0 signal circuit" is incorporated (see Fig. 12). Upon release of the "dMd0" signal, the "Stgv0" signal is cut off (see Videoton-340 display description, Vol. I-II, Fig. 6.8, Section 6.5.3). This makes it possible to synchronize the exchange between the display and electric typewriter. Line delay LZ3 is intended to cut off a poorly formed "-letter lever" signal. The line delay is made of a K2GF182 univibrator. This circuit also is used in the "On line-Read" mode. During operation of the text

display, signals "VI" "AI," and "KT" are delivered from the push buttons of a small panel, connected in parallel with like push buttons of the Consul-26001 electric typewriter.

Conclusion

The unit described, used for communications between the computer and the Videoton-340 text display, has received good reports from Academy of Sciences USSR, Institute of Space Research users. They note its reliability, high information output rate, noiselessness and convenience of the keyboard. From the point of view of the users, the unit also has proved to be a good tool for localization of failures in the MK channel and interference. For the long range, further modifications of this unit are possible.

/9

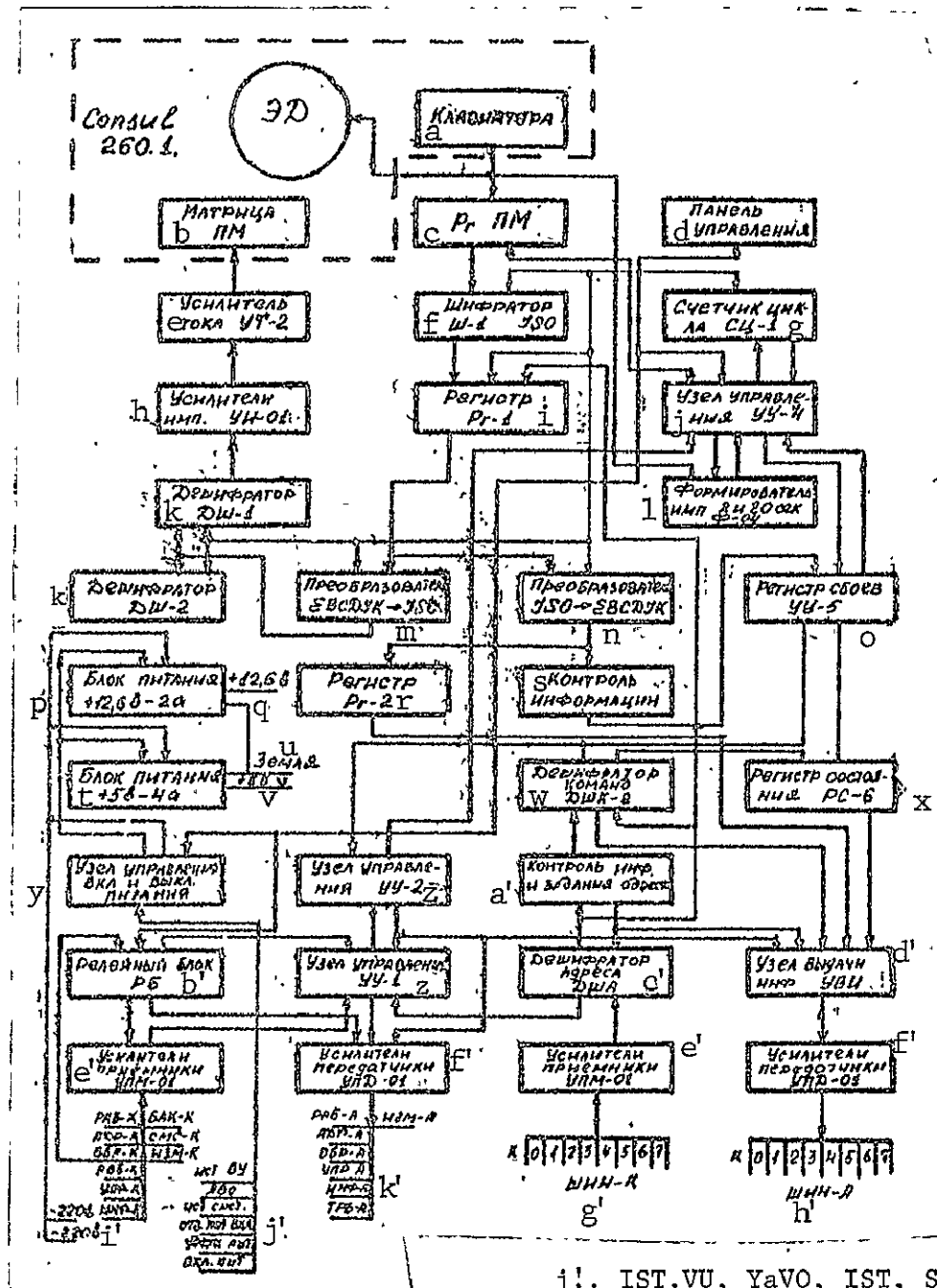

- Key:
- a. keyboard
 - b. typewriter matrix
 - c. Pr PM [typewriter, printer]
 - d. control panel
 - e. current amplifier UT-2
 - f. coder SK-1 ISO
 - g. cycle counter STs-1
 - h. pulse amplifier UI-01
 - i. register Pr-1
 - j. control block YY-4
 - k. decoder DSh-1, 2
 - l. 2 and 20 sec pulse shaper F-04
 - m. dVSDUK→ISO converter
 - n. ISO→dVSDUK converter
 - o. interrupt register YY-5
 - p. +12.6V 2A power pack
 - q. +12.6V
 - r. register Pr-2
 - s. information control
 - t. +5V, 4A power pack
 - u. ground
 - v. +5V
 - w. command decoder DShK-2
 - x. status register RS-6
 - y. power connection and disconnection control block
 - z. control block YY
 - a': information and image output control
 - b': relay block RB
 - c': address decoder DShA
 - d': information output unit UVI
 - e': receiver amplifiers UPM-01
 - f': transmitter amplifiers UPD-01
 - g': bus K
 - h': bus A
 - i': RAB-Z, BAK-K; [illegible], SMS-K; VBR-K, NZM-K; RVB-K; UNF-K; MNF-K; -220V; -220V

Fig. 1.

j!. IST.VU, YaVO, IST, SIST., [illegible, illegible, illegible, illegible]

k'. RAB-A, IdM-A; ADR-A; VBR-A; ULR-A; INF-A: TRB-A

"Signal contact-start STs-1
signal shaping circuit

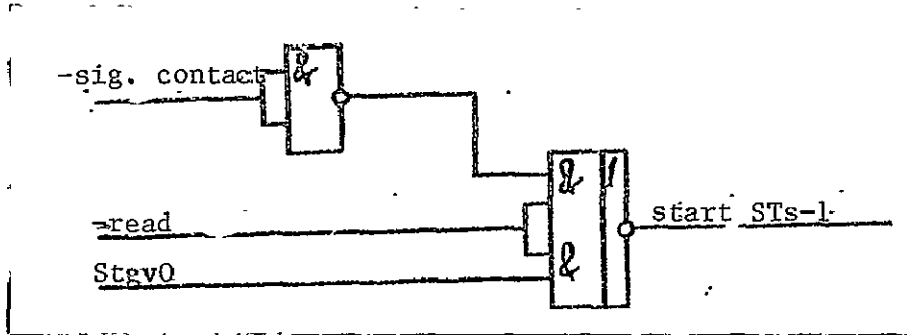

upper and lower register
switching circuit

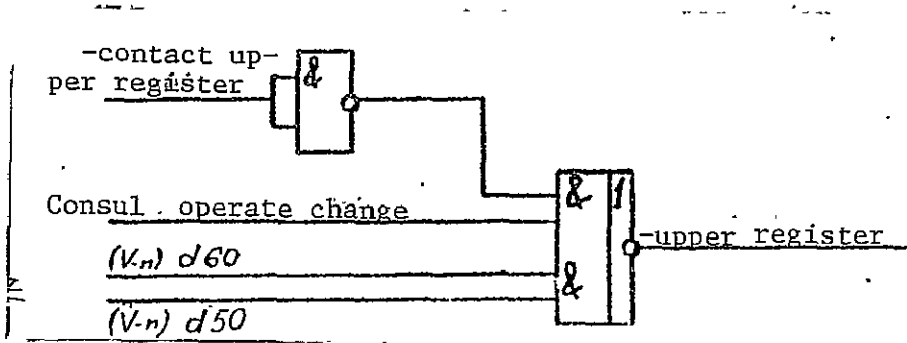

Fig. 2.

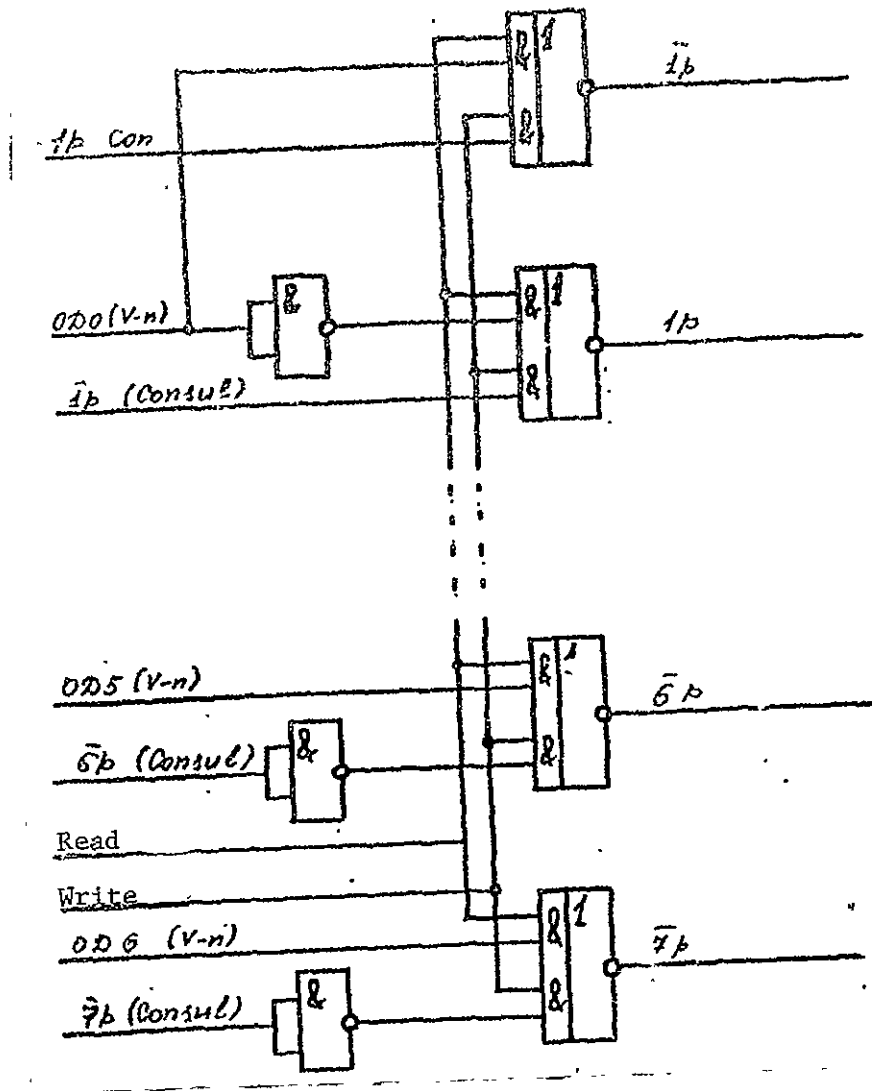

Fig. 3.

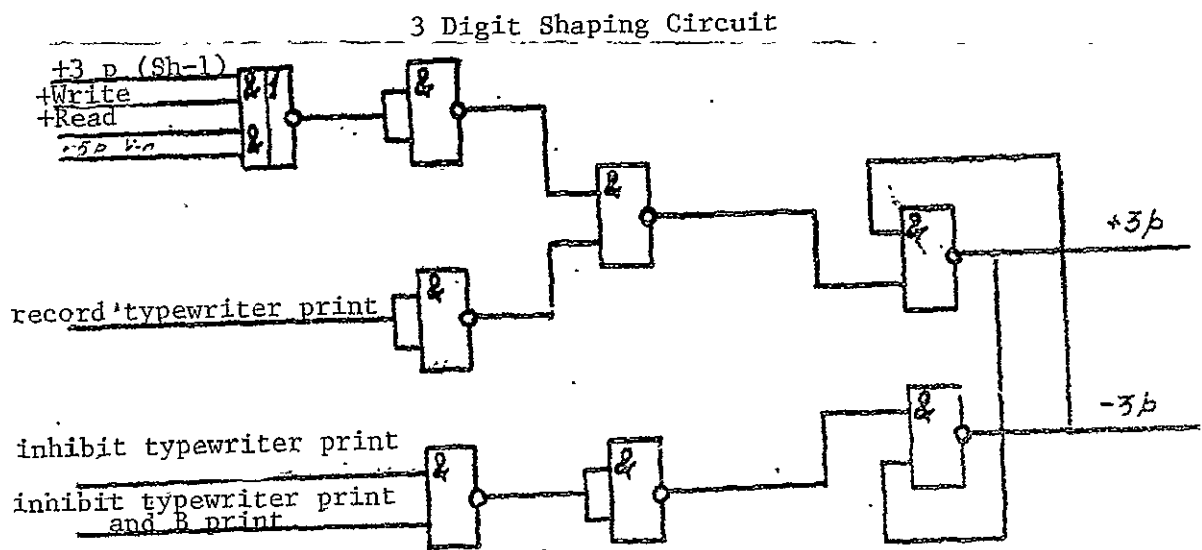

Fig. 4.

"StgVI" Signal Shaping Circuit

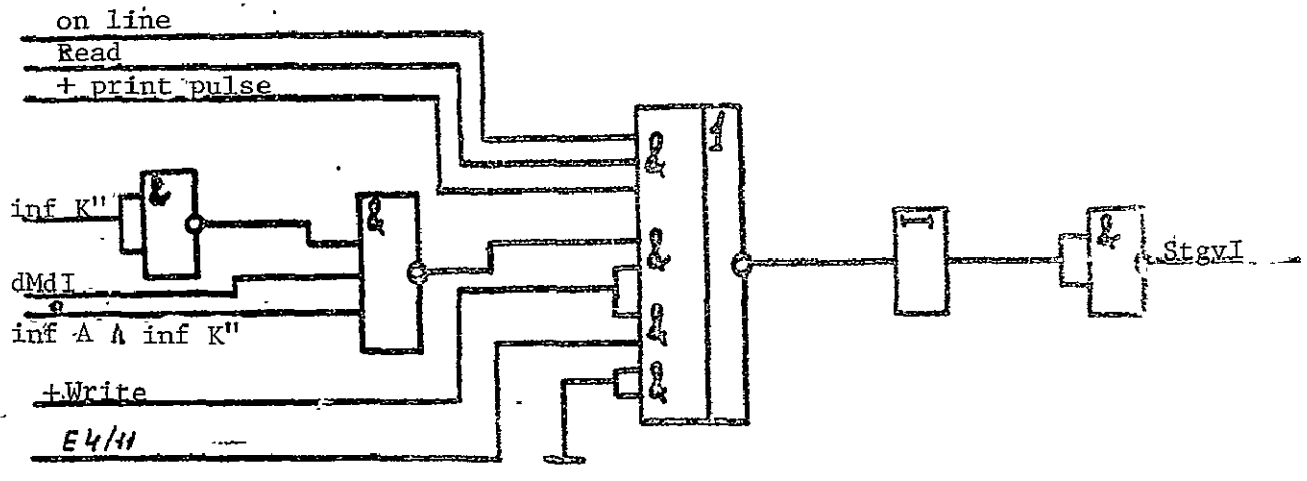

Fig. 5.

"-Vkl. Tr. st. Pr." "+print pulse"
Signal Inhibition Circuit

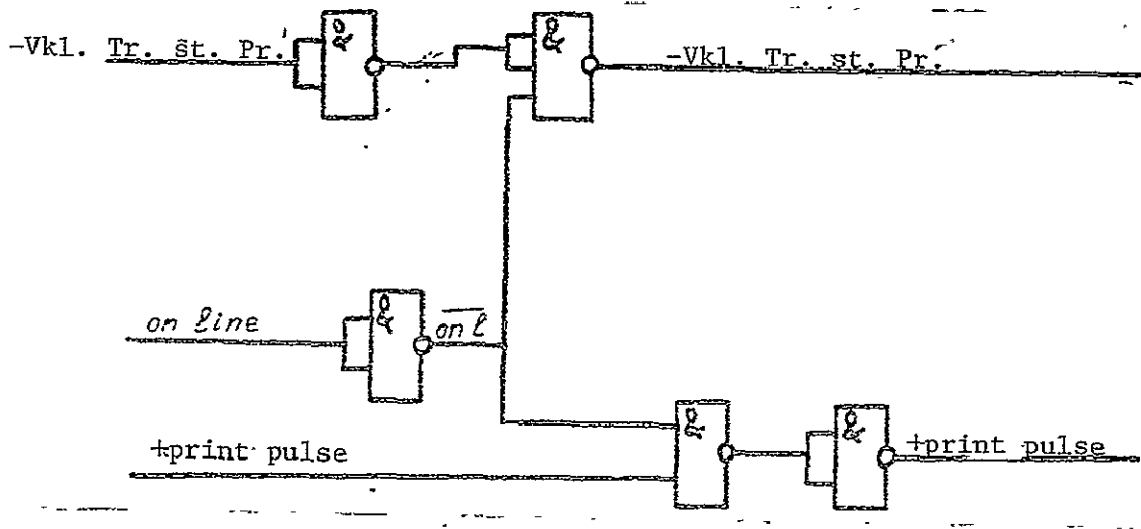

Fig. 6.

Cycle Start Inhibition Circuit

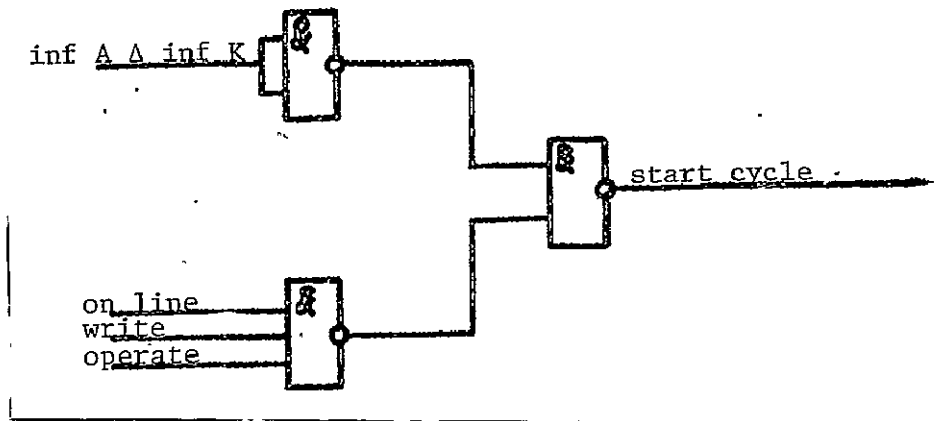

Fig. 7.

Trb. A Signal Shaping Circuit

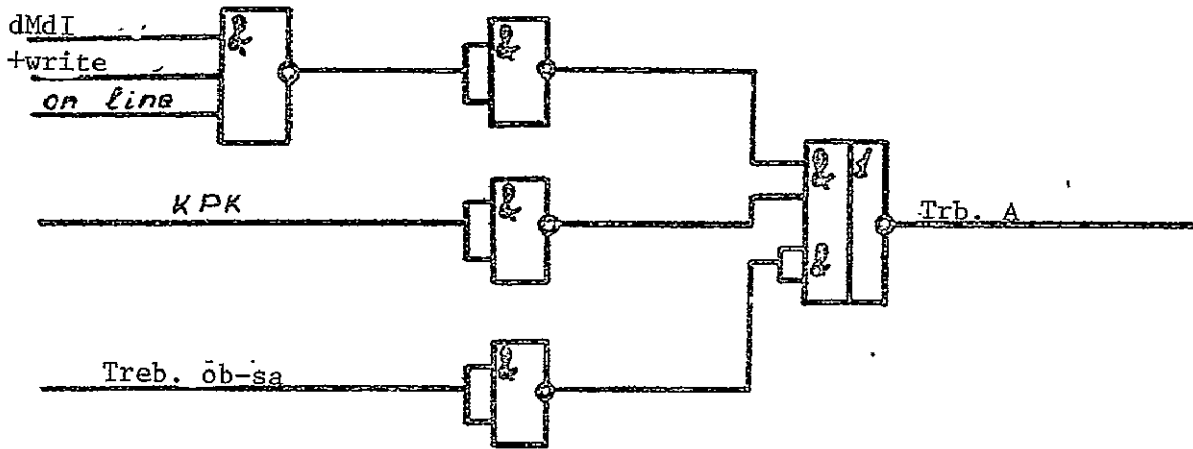

Fig. 8.

"inhibit typewriter print"
signal shaping circuit

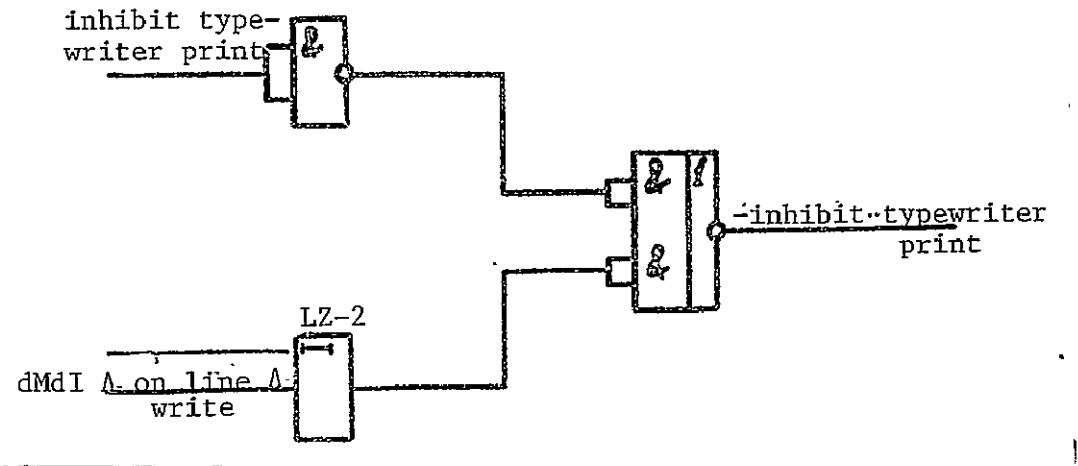

Fig. 9.

Line Feed Signal Shaping Circuit

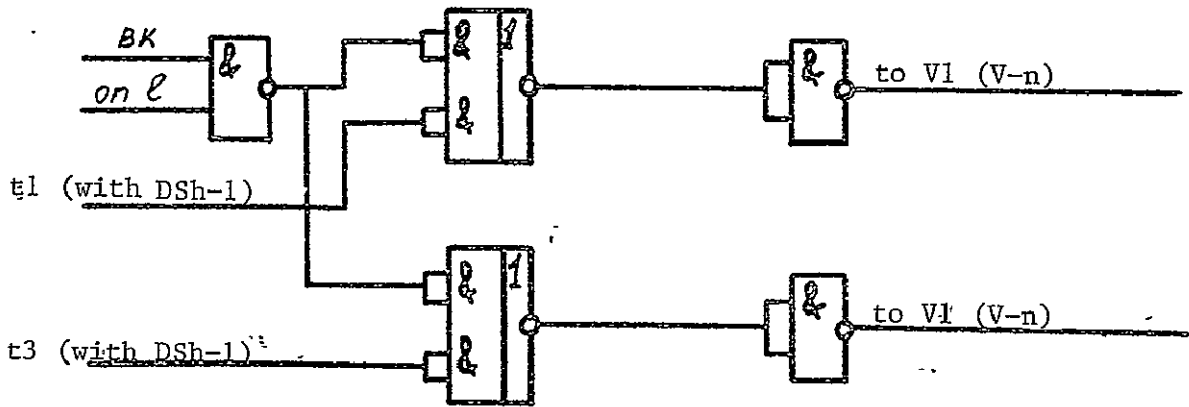

Fig. 10.

Tr. VK Dump by Means of
Tr 3VK Circuit

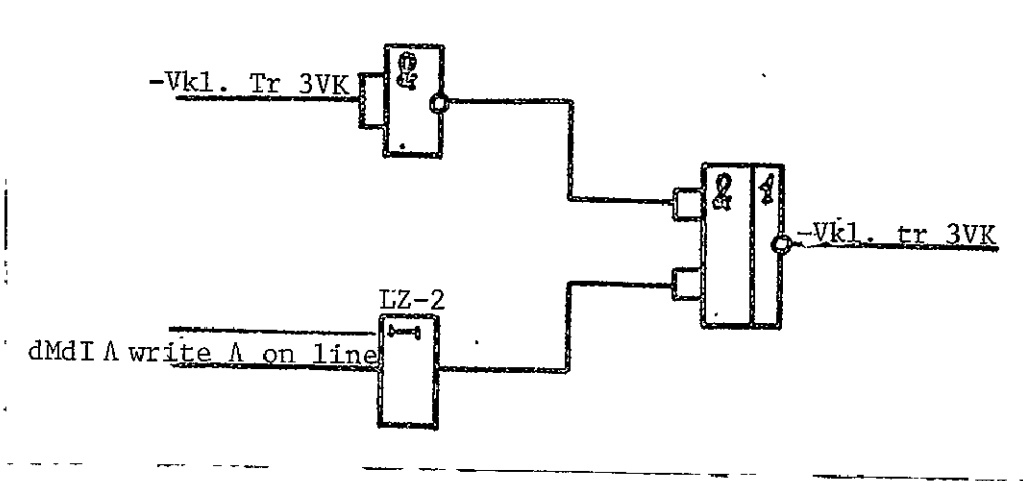

Fig. 11.

"DMDO" Signal Shaping Circuit

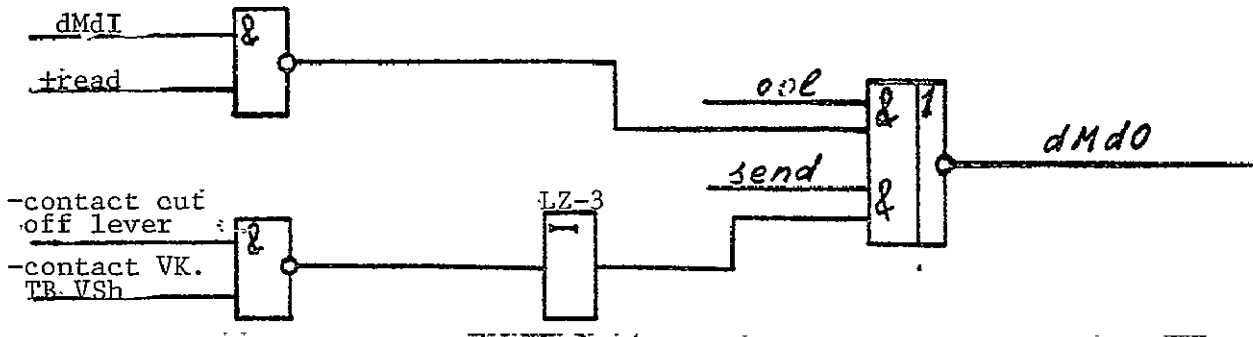

Fig. 12.