

(NASA-CR-161225) DEVELOPMENT OF SENSITIZED
PICK COAL INTERFACE DETECTOR SYSTEM Final
Report (Shaker Research Corp., Ballston
Lake, N. Y.) 67 P HC A04/MF A01 CSCI 08I

N79-24417

Unclas
20892

G3/43

FINAL REPORT

For

NAS8-32538

DEVELOPMENT OF SENSITIZED PICK
COAL INTERFACE DETECTOR SYSTEM

Prepared By

R. F. Burchill

Prepared For

George C. Marshall Space Flight Center
Marshall Space Flight Center
Alabama 35812

Under the Director of

John L. Burch
Contracting Representative
EC25/205-453-3447

SHAKER RESEARCH CORPORATION
Northway 10 Executive Park
Ballston Lake, N.Y. 12019



TABLE OF CONTENTS

	<u>Page</u>
1.0 INTRODUCTION -----	1-1
2.0 TRANSDUCER SYSTEM DESIGN -----	2-1
2.1 Sensitized Pick Load/Shock Sensor -----	2-1
2.2 Telemetry Transmitter Design -----	2-10
2.3 Telemetry Receiver Design -----	2-17
2.4 MESA Permission -----	2-23
2.5 State of Pennsylvania Permission -----	2-23
3.0 MINE SIMULATION TESTING -----	3-1
3.1 Test Installation -----	3-2
3.2 Test Results -----	3-6
3.3 Equipment Modification After Test -----	3-10
4.0 DATA COLLECTION IN AN OPERATING COAL MINE -----	4-1
4.1 Mine Selection -----	4-1
4.2 Test Installation - Jane Mine -----	4-2
4.3 Mine Test Results -----	4-5
4.4 Tape Data Review -----	4-13
5.0 CONCLUSIONS AND RECOMMENDATIONS -----	5-1

LIST OF FIGURES

	<u>Page</u>
2-1 Instrumented Pick Block (Original Design) _____	2-2
2-2 Assembly, Instrumented Pick _____	2-3
2-3 Drum Position _____	2-5
2-4 Pick Location and Illustration _____	2-6
2-5 Bruceston Drum - Trailing Pick Placement Sensitized Pick _____	2-8
2-6 Drum Position _____	2-9
2-7 T20B Strain Gage Transmitter FM-FM _____	2-12
2-8 T20G High Impedance Accelerometer Transmitter FM _____	2-15
2-9 Transmitter Mounting Assembly _____	2-16
2-10 Tape Recorder and Mine Telemetry Receiver _____	2-18
2-11 Mine Telemetry Receiver _____	2-19
2-12 Receiver Battery Assembly _____	2-21
2-13 Speed/Phase Transducer _____	2-22
2-14 Model No. SR-100 Mine Test System Block Diagram _____	2-24
3-1 Shadow Pick Installation _____	3-3
3-2 Welding Reinforcement Shadow Pick Installation _____	3-4
3-3 Mining Machine Instrumentation _____	3-5
3-4 Strain Sensor Output _____	3-8

List of Figures (Continued)

	<u>Page</u>
4-1 Jane Mine Instrument Box Laboratory View With Recorder Shock Mount -----	4-4
4-2 Sensitized Pick Instrumentation -----	4-11
4-3 Low Frequency Shadow Pick Test Data 3-1/4" Bit Length 0-125 Hz Recorder Response -----	4-15
4-4 Low Frequency Shadow Pick Test Data 3" Bit Length 0-125 Hz Recorder Response -----	4-16
4-5 Load Cell Response Standard Pick W/O Lead Pick Spectrum Analysis -----	4-17

LIST OF TABLES

	<u>Page</u>
4-1 NASA Mine Test	4-8
4-2 Detailed Sensor Description	4-9
4-3 Sensitized Pick Coal Interface Detector	4-12

1.0 INTRODUCTION

The current trends in coal mining are directed toward improved mining techniques and higher coal production rates. One approach being considered is the automation of cutter drum ranging on long wall type mining machines. This necessitates development of an automatic detection system for determination of the locations of the boundaries of the coal seam. The feasibility of such a system is obviously dependent upon the ability to detect changes in cutting characteristics as the cutting picks are cutting other than coal. One approach for detection of the coal interface is measurement of the pick cutting loads and shock through the use of pick strain gage load cells and accelerometers. This technique, which was applied in the present program is an extension of work done by the National Coal Board in England in the mid-1960's.

The cutting drum of a long wall mining machine contains a number of cutting picks. In order to measure pick loads and shocks, one pick was instrumented and telemetry used to transmit the signals from the drum to an instrument-type tape recorder.

A data system using FM telemetry was designed under NASA Contract NAS8-31668 by Shaker Research Corporation to transfer cutting bit load and shock information from the drum of a longwall shearer coal mining machine to a chassis mounted data recorder. The purpose of the present work was to finalize the design of components in the test data system, procure and assemble the required instruments, evaluate the instrument system in an above-ground simulation test, and conduct an underground test series to obtain tape recorded sensor data which can be used by NASA personnel to develop long-wall mining machine control systems. Three task phases were planned to accomplish this purpose:

Task I: Detail design, procure and assemble data system. Obtain MESA and State of Pennsylvania mine use permits.

Task II: Mine simulation test evaluation of system components at Bruce-ton Station, Pennsylvania.

Task III: Design, installation, and test of several alternate sensitized pick concepts in an operating coal mine to obtain tape recorded data for NASA application.

In addition to the sensitized pick coal interface detector "CID" instrumentation, several additional transducers were incorporated into the measurement system to permit further evaluation of mining machine performance and to ease the application of test data. A cutting drum phase indicator device was added so that the position of each sensitized pick would be independently identifiable. Also, a mining machine chassis accelerometer electronics assembly was added to permit correlation with other measurement techniques being considered for mining machine control.

As with other instrumentation developed for mine use, this system was designed such that individual components are powered by self-contained batteries so that no power is required from the machine being tested.

Intrinsic safety is provided by resistance current limiting of batteries and selection of low power storage electronic components. Where possible, commercially-available components were used to insure maximum reliability and serviceability.

The sensitized pick coal interface detection measurement system assembled under this contract has provided test measurement capability in the difficult operating conditions of a producing coal mine.

2.0 TRANSDUCER SYSTEM DESIGN

The transducer system design for this project can be broken down into three major components: the sensitized pick load/shock sensor, the pick sensor telemetry system, and the auxiliary instrumentation for mining machine performance characterization. Each of these components will be reviewed in some detail.

2.1 Sensitized Pick Load/Shock Sensor

The concept of the sensitized pick as a measurement device for the detection of the boundaries of a coal seam dates back to the early 1950's, but the published data available are from British National Coal Board work in the mid-1960's. Sufficient development work was done using pick cutting force to allow automatic ranging of cutting drums based upon the differences in output signal between cutting coal and cutting rock or soft clay. This work was discontinued when other coal interface detectors appeared to be more universally applicable.

Under Contract NAS8-31668, Shaker Research Corporation designed an instrumented pick block (see Figure 2-1) which permitted measurement of cutting bit force and shock using a shank-contacting load sensor and accelerometer. This design had the advantage of allowing the use of a standard cutting bit, but was somewhat cumbersome to apply because of increased block length to contain the load/shock elements. A redesign effort produced the significantly more compact configuration shown as Figure 2-2 which can be much more easily applied. The load and shock sensing elements are directly preloaded against the cutting bit shank so that the action of coal cutting loads the bit tip and further compresses the sensor element. Foil strain gages bonded to the thin cylindrical load cell provide electrical resistance change with load change to provide static and dynamic response.

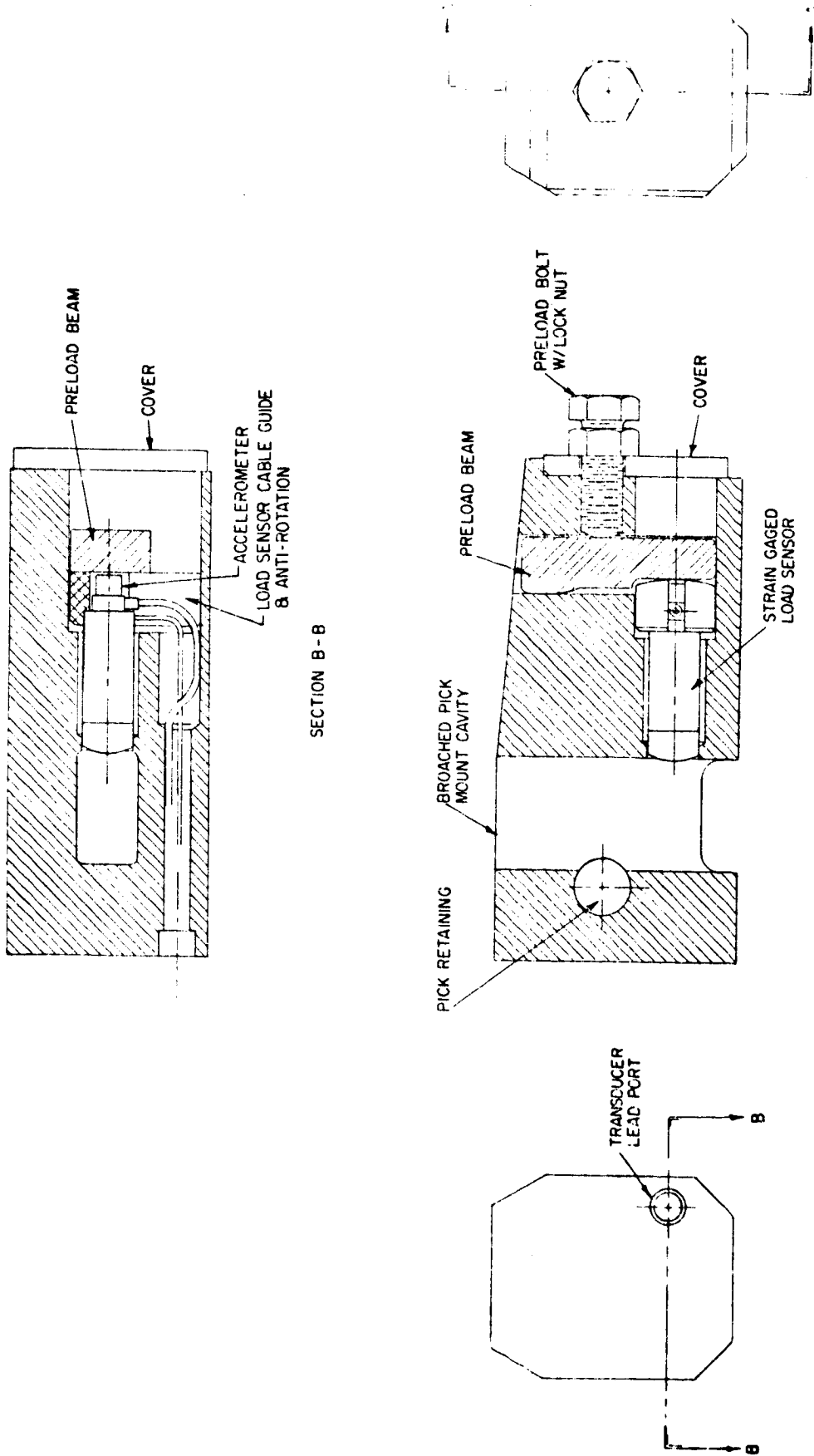

INSTRUMENTED PICK BLOCK
(Original Design)

Figure 2-1

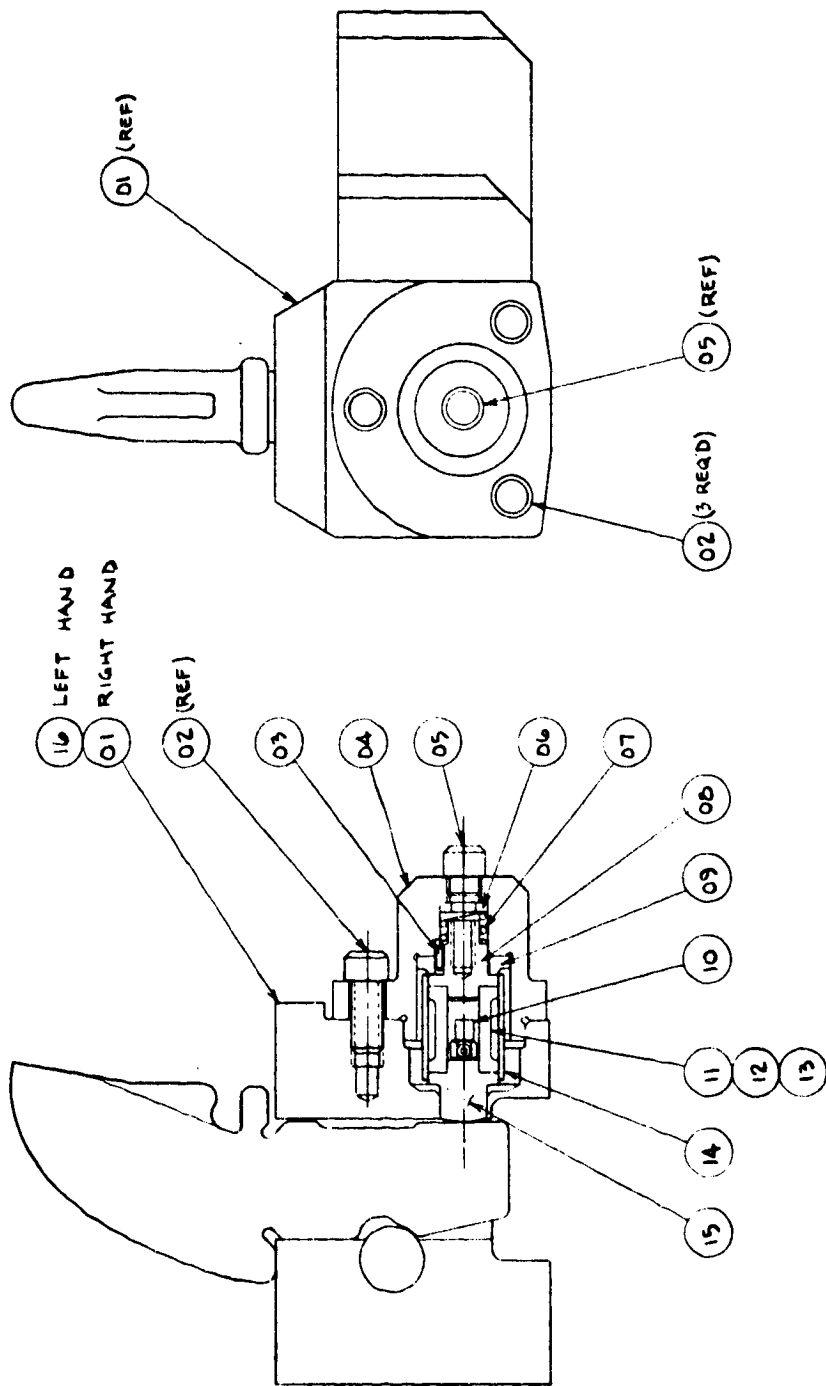

G1 RIGHT HAND

G2 LEFT HAND

Figure 2-2

SHAKER RESEARCH CORPORATION <small>PROBABLE TO EXISTENCE FROM BALLISTON LINE 100 100 100</small>		TITLE ASSEMBLY, INSTRUMENTED <i>ADK</i>	
DIMENSIONAL TOLERANCES UNLESS OTHERWISE SPECIFIED: DECIMALS ± 0.015 FRACTIONS ± 1/32 3 PLACES ± 0.005 SURFACE FINISH 125 BREAK SHARP CORNER; REMOVE ALL BURRS.		DRAWN <i>GLW</i>	CHECKED <i>ADK</i>
DIMENSIONS IN INCHES UNLESS OTHERWISE SPECIFIED	SCALE 1/1	DRAWING NUMBER 117-C-125	SHEET OF REV ED

It is assumed that the loads and/or cutting character will be different for the different materials experienced in mining. As coal is a pre-fractured material it breaks away from a cutting bit in a different fashion than slate, shale, clay, or other common seam boundary materials. Direct load measurement has been used as a sensed parameter, but also it seems likely that the shock response of cutting could be significantly different for the different materials. The components selected for this sensitized pick design allow measurement of static and dynamic load values and low frequency and high frequency shock responses, using a strain gaged load cell and a miniature piezoelectric crystal accelerometer.

The measurement of bit load takes on some interesting aspects when one considers the influence of depth of cut upon cutting force. For homogeneous material it would seem reasonable to expect that forces are related to depth of penetration as in a shaping or plowing action where power per cubic measure per unit time is a reasonably fixed value for a particular material. The cutting action for a longwall shearer is complicated by the variation in cut depth as any particular bit revolves, with 180 arc degrees of zero depth cut, minimum depth at ceiling and floor, and maximum penetration when the bit is at mid-seam. The shape of the depth of cut cycle for a typical operating system (56" diameter double wrap drum, 60 rpm drum speed, and 15 fpm traverse rate) is shown as Figure 2-3. The portion of the cut cycle of interest in a drum guidance system is the top (0°) and bottom (180°) sectors over about 10° to 20° of rotation. These portions of the cutting arc are prone to rather significant variations in depth of cut in normal mining as the mined material breaks away in somewhat irregular pieces, presenting either a void or a significant projection to the initial contact of the pick. Figure 2-4 shows the mounting of a sensitized pick block in a standard drum lacing array, along with the telemetry transmitter mounting case. The compact dimensions of the redesigned sensitized pick block permits it to be mounted with only minor shifting of adjacent blocks.

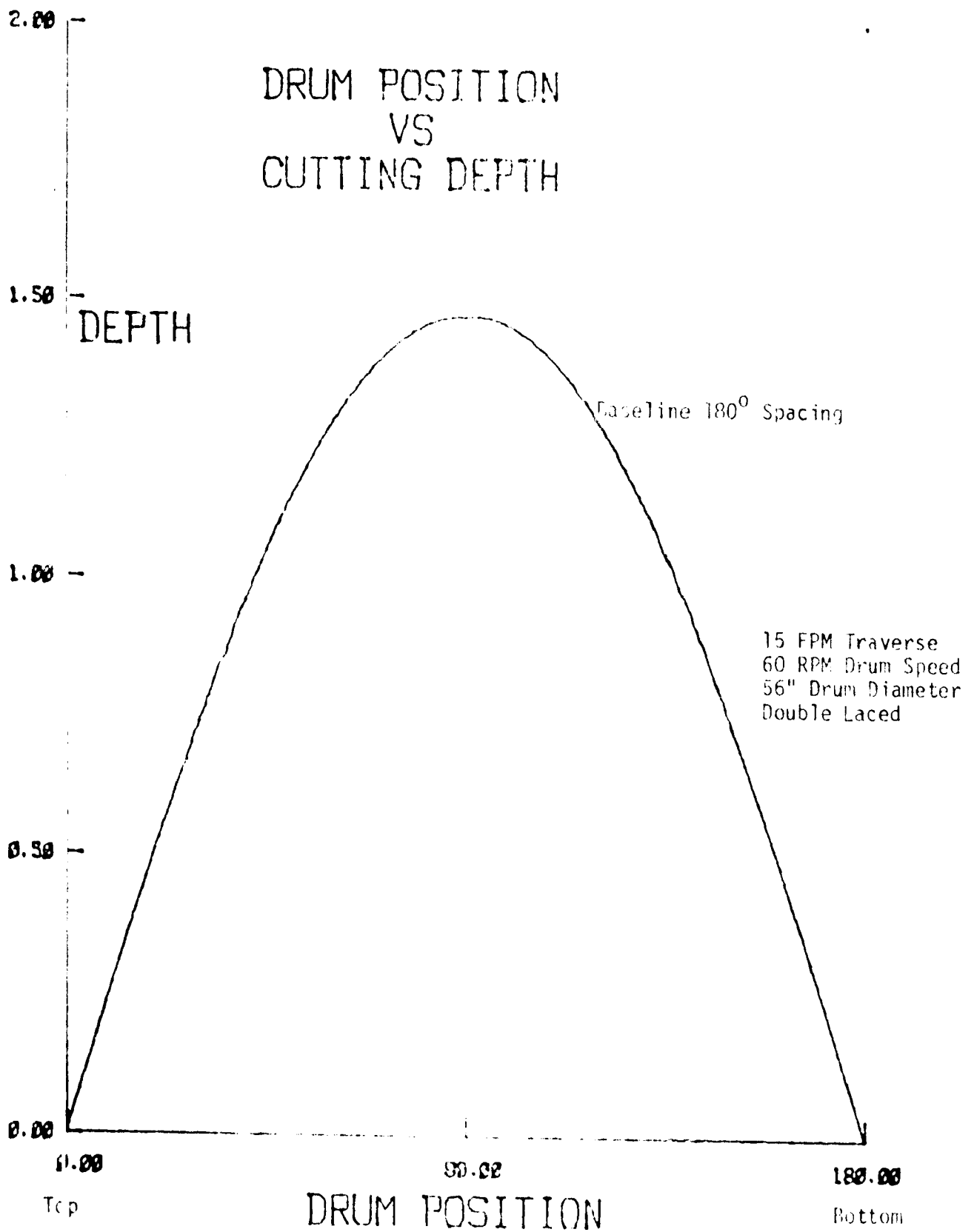
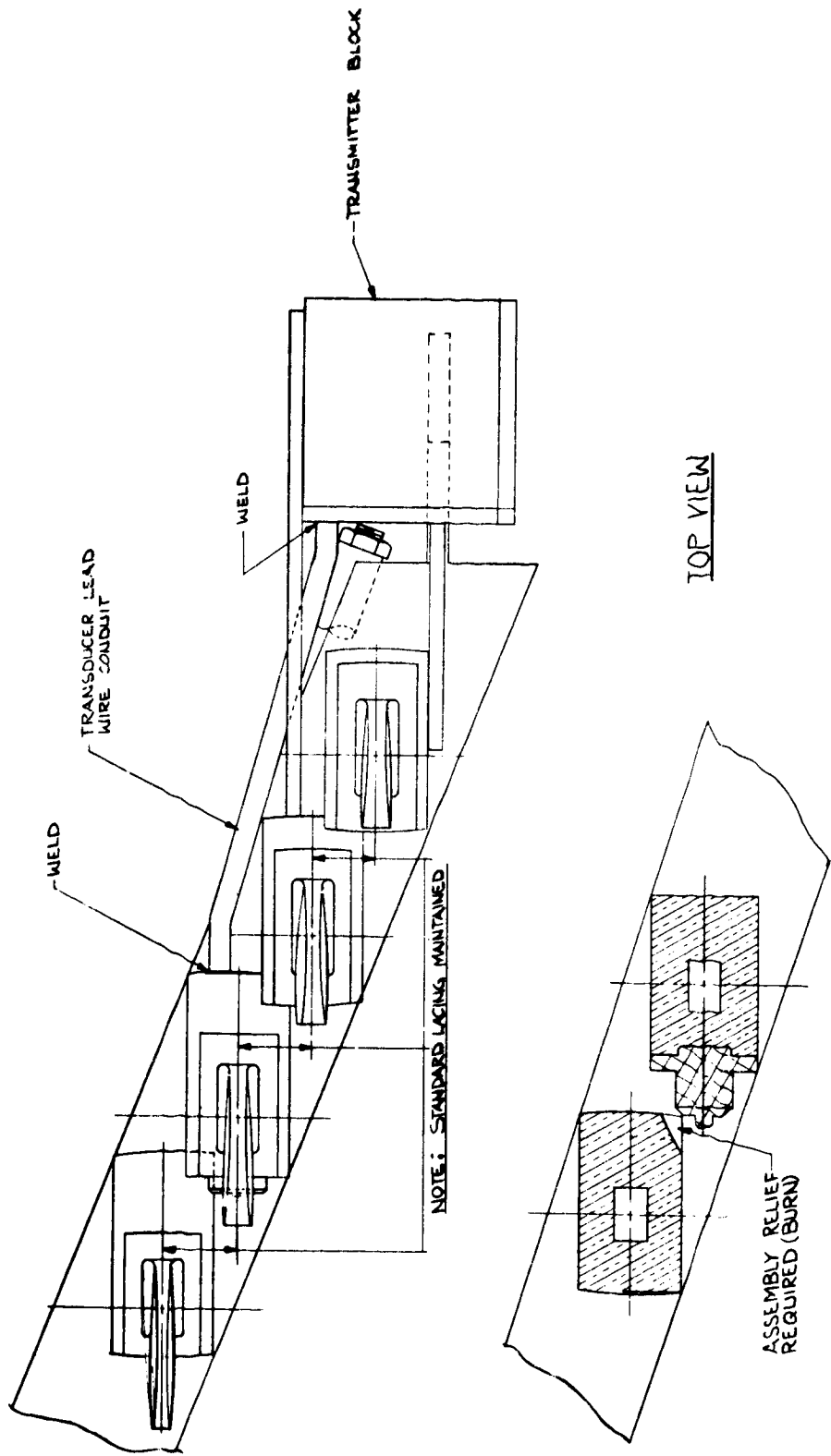
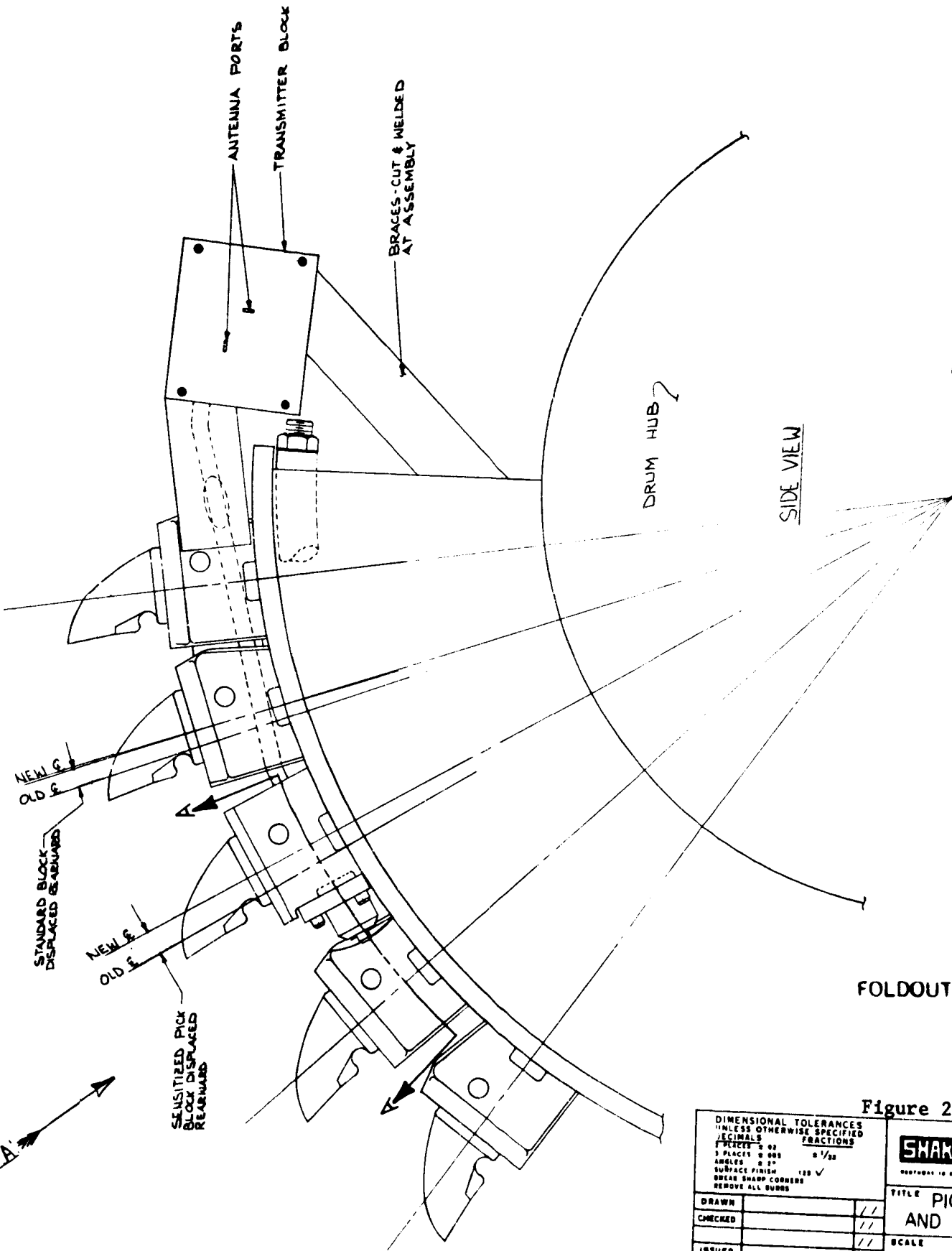

Figure 2-3

FOLDOUT FRAME |





JANE MINE
 DRUM INSTALLATION
 STANDARD BIT PLACEMENT
 SENSITIZED PICK

FOLDOUT FRAME 2

Figure 2-4

DIMENSIONAL TOLERANCES UNLESS OTHERWISE SPECIFIED DECIMALS FRACTIONS ± PERCENT ± 0.00 ± 1/32 3 PLACES ± 0.005 ± 1/64 ANGLES ± 1' ± 15" SURFACE FINISH 125 ✓ BREAK SHARP CORNERS REMOVE ALL BURRS		SHAKER RESEARCH CORPORATION HEADQUARTERS 10 EXECUTIVE PARK BALLETS LAKE BOULEVARD 10000	
DRAWN _____ // CHECKED _____ // ISSUED _____ //		TITLE PICK LOCATION AND ILLUSTRATION SCALE HALF DRAWING NUMBER 117-0-127 SHEET 1 OF 2 REV	

Concern for the repeatability of the initial and final cut of a standard array bit prompted investigation of an alternative pick mounting configuration. Figure 2-5 shows the sensitized pick block mounted behind one of the normal array blocks in a "shadow" arrangement which gives some interesting possibilities for measurement variation with different length cutting bits. A nearly ideal detection system would be available if the drum could be controlled to cut to the limits of the coal seam but no further: maximum coal recovery would result with minimum rock or dirt included in the final product, and maximum tool life would be obtained by not shearing rock. Extending the control bit length beyond the rest of the cutting bits in the drum would, with a suitably sensitive system, permit only that bit to contact rock or clay while all others were kept in coal, but if the extended bit were in the standard array it would experience very high cutting forces when it was in the 90° arc plane (maximum depth) as any extension of length adds directly to the depth of cut curve across the complete cutting cycle. The shadow pick arrangement avoids this severe cutting cycle as the pick just ahead takes all the variation in depth with angular position, so the corresponding cutting depths are shown as the lower four curves on Figure 2-6. This cutting depth analysis is for a shadow pick 15 arc degrees behind one standard array pick. Although the cutting action of coal is much less regular than this idealized depth analysis presented here, the trends should follow the curves somewhat and it appears that a shadow pick design should permit good resolution of cutting action at the beginning and end of the cut, and reasonable levels at mid-cycle so that structural strength requirements and wear are minimized. (The broad arc contact of reasonably constant cutting force should also allow an every-revolution evaluation of cutting bit sharpness so that a normalizing process can be used to eliminate tool wear and coal hardness variations.)

FOLDOUT FRAME /

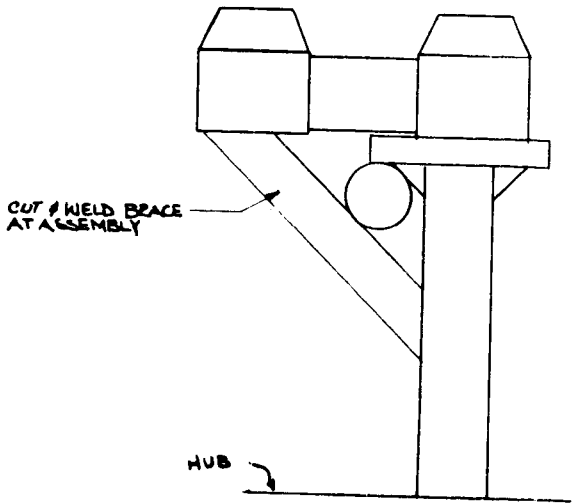

SECTION A-A

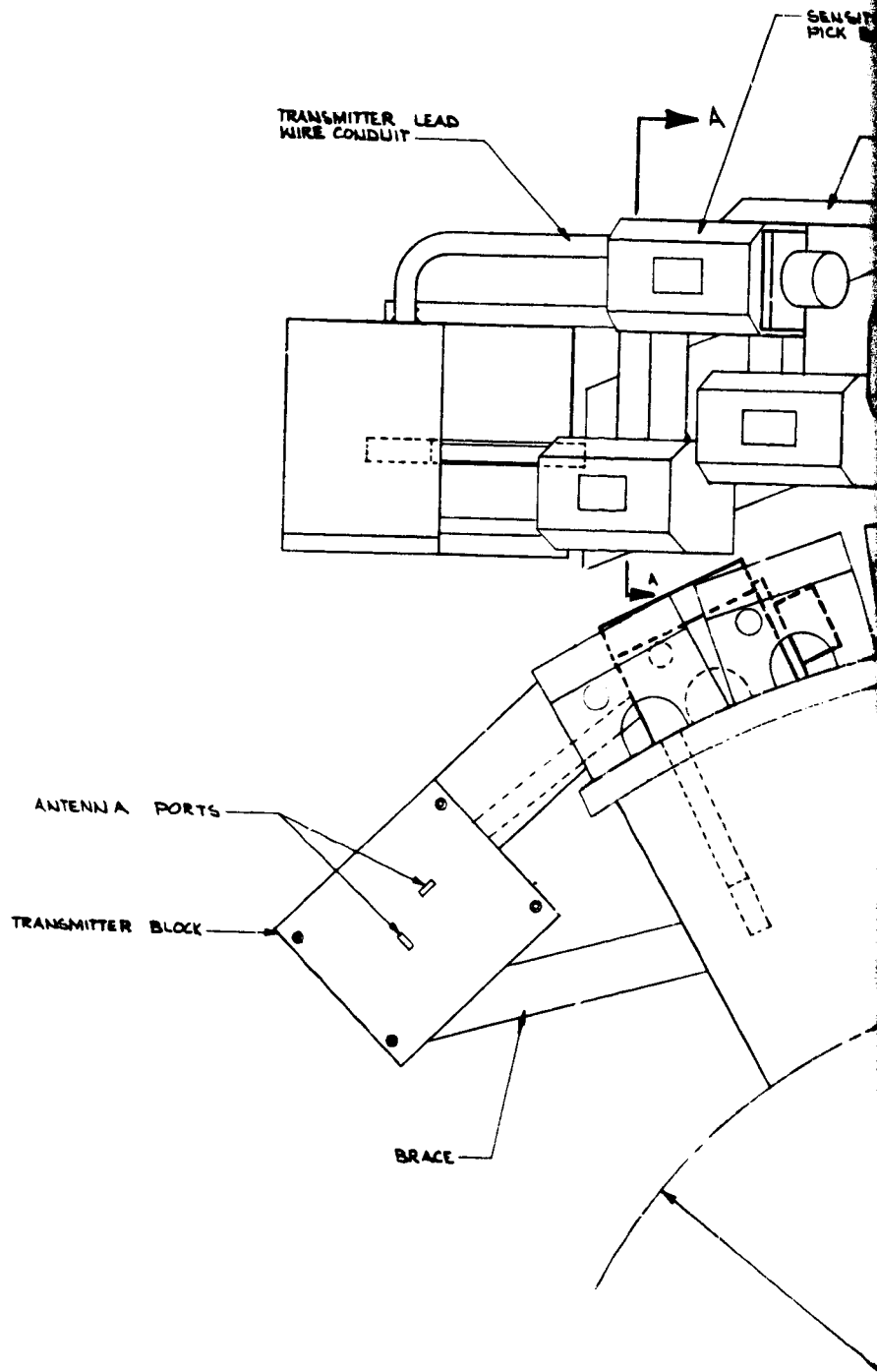

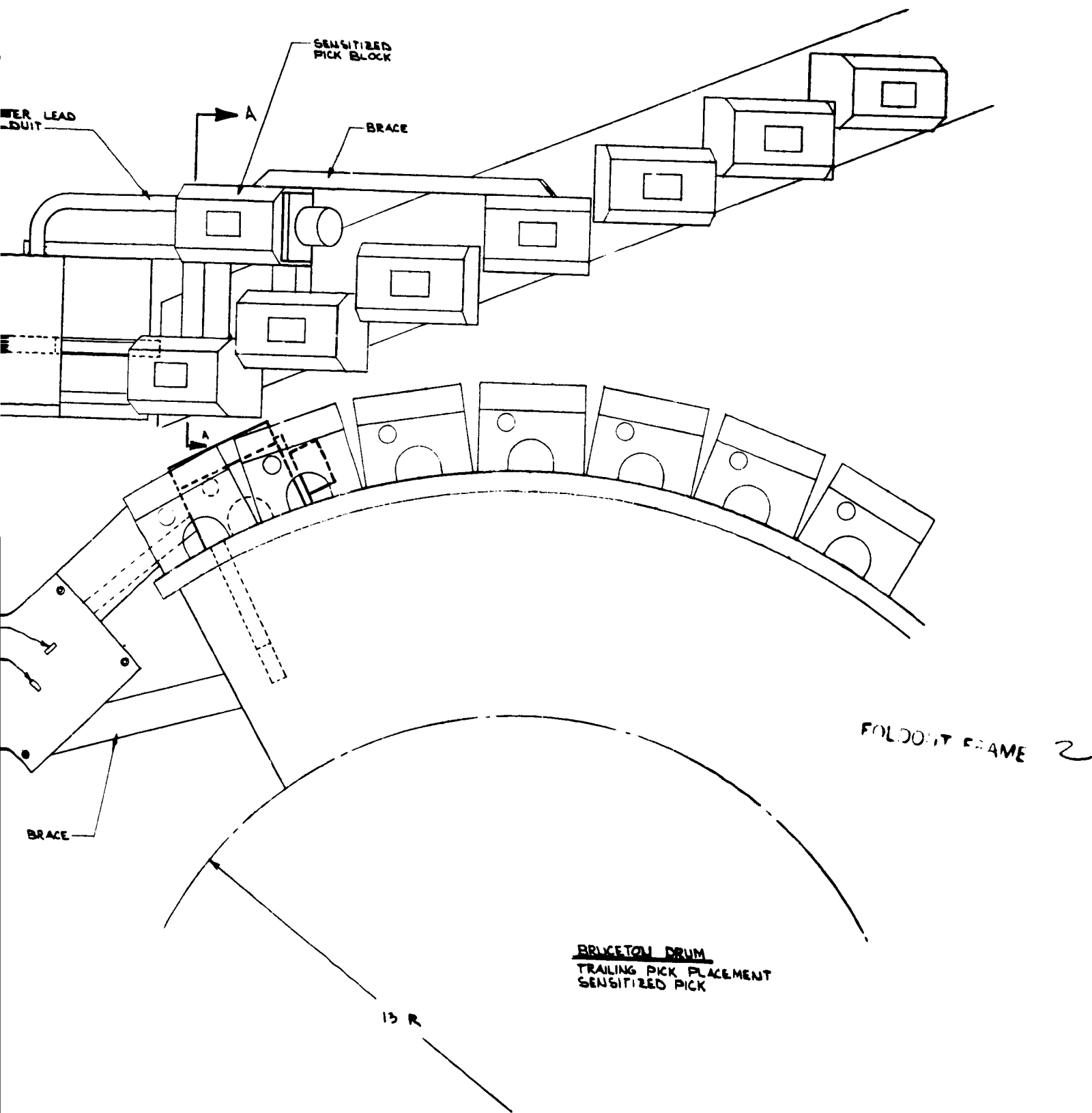

Figure 2-5

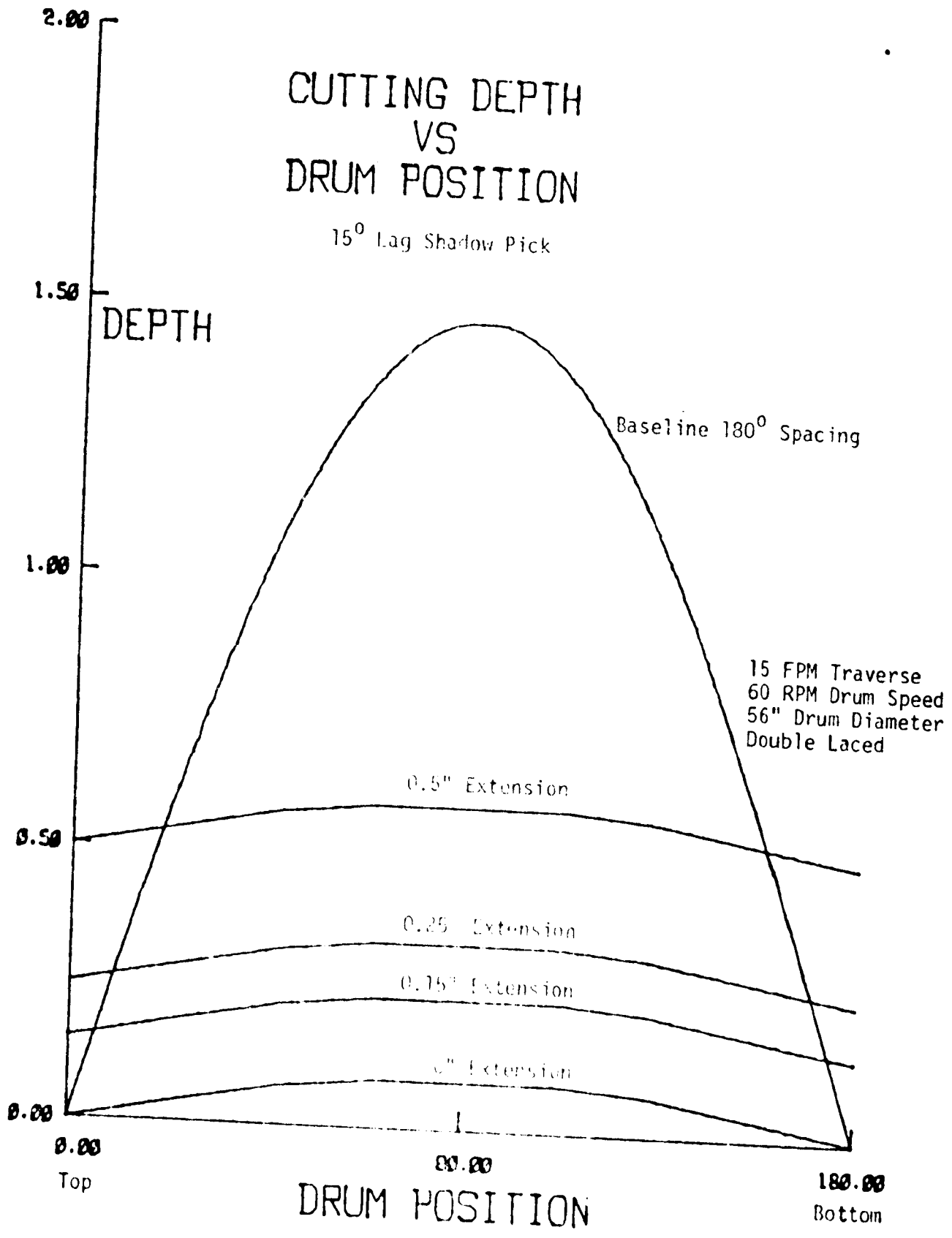

Figure 2-6

The rationale behind bit shock measurement is not so clear-cut as for bit load detection, but a shock accelerometer was included to further characterize cutting action. At present the mining machine operator can readily detect penetration into the rock ceiling by the sound produced and the vibration character of the mining machine chassis. Detection of shock at the cutting bit should provide a discrimination capability approaching that possible by a sensitive human being, although the integration capability of an experienced operator with multiple sensing inputs is extremely difficult to compete with in something as complicated as machine control.

2.2 Telemetry Transmitter Design

The telemetry electronics components used in this data system were fabricated for Shaker Research Corporation by Inmet, Inc. of Indian Harbour Beach, Florida. Where possible, standard production designs were specified, but some unique requirements did force modification. The unique features will be discussed under operating details.

Low power data telemetry systems operate under the same FCC classification as for wireless FM microphones. Transmitters include a tuning coil so that each can be adjusted to a frequency between 88 Megahertz and 108 Megahertz to a spot where interference is minimal. Usually 1.5 to 2.0 Megahertz difference is set between the telemetry transmitters in the same area, and then fine tuning of each is done to avoid local FM radio broadcast station frequencies.

The normal transmission distance from low power telemetry transmitters is 50 to 100 feet, but under ideal free space conditions can extend to several thousand feet. Transmission in narrow tunnels presents some different problems but those occur at distances above 100 feet and will not be of concern in this program. It is conceived that normally all data transmission will be from a cutting drum to a chassis receiver location so the operating distance will be relatively fixed at 15-30 feet. It is possible

to use the receiver assembly away from the mining machine, but test data would be of limited value without additional machine performance parameters which relate sensitized pick outputs to machine response.

The pick load sensor output is broadcasted by an FM-FM transmitter system with built-in strain gage bridge completion circuitry. Four 350 Ohm foil gages are bonded to the load cell, two longitudinal compression gages and two circumferential compensating gages, to provide good strain sensitivity with temperature compensation. A constant current excitation of 5.5 ma powers the bridge, and maximum sensitivity with four active gages is $\pm 125\mu$ strain full scale. Sensitivity can be decreased by the addition of external bridge attenuator resistors for strain levels in excess of 125μ strain. The FM-FM system is used to allow static strain values to be measured, and in this design a sub-carrier oscillator (SCO) frequency of 10 KHz is varied with strain level to provide dynamic response of up to 2 KHz. The hookup for the strain transmitters is shown on Figure 2-7. Several features have been added to the standard transmitter to improve applicability to the mine test environment. They are:

- A. Selective grounding to avoid RF transmission problems
- B. A carbon resistor transmitting antenna recess mounted in the steel cover to provide protection from mechanical (abrasive) damage and freedom from antenna vibration-induced noise.
- C. An auxiliary bridge balance circuit was added to permit compensation for greater gage resistance deviation.
- D. Strain attenuation resistors were added to cut down on circuit sensitivity.

Each strain transmitter is mounted in an aluminum block (along with the battery and corresponding shock accelerometer transmitter) which is in turn bolted into a steel case that is welded to the drum behind the sensitized pick block. No cables or electronics are in place during the welding process.

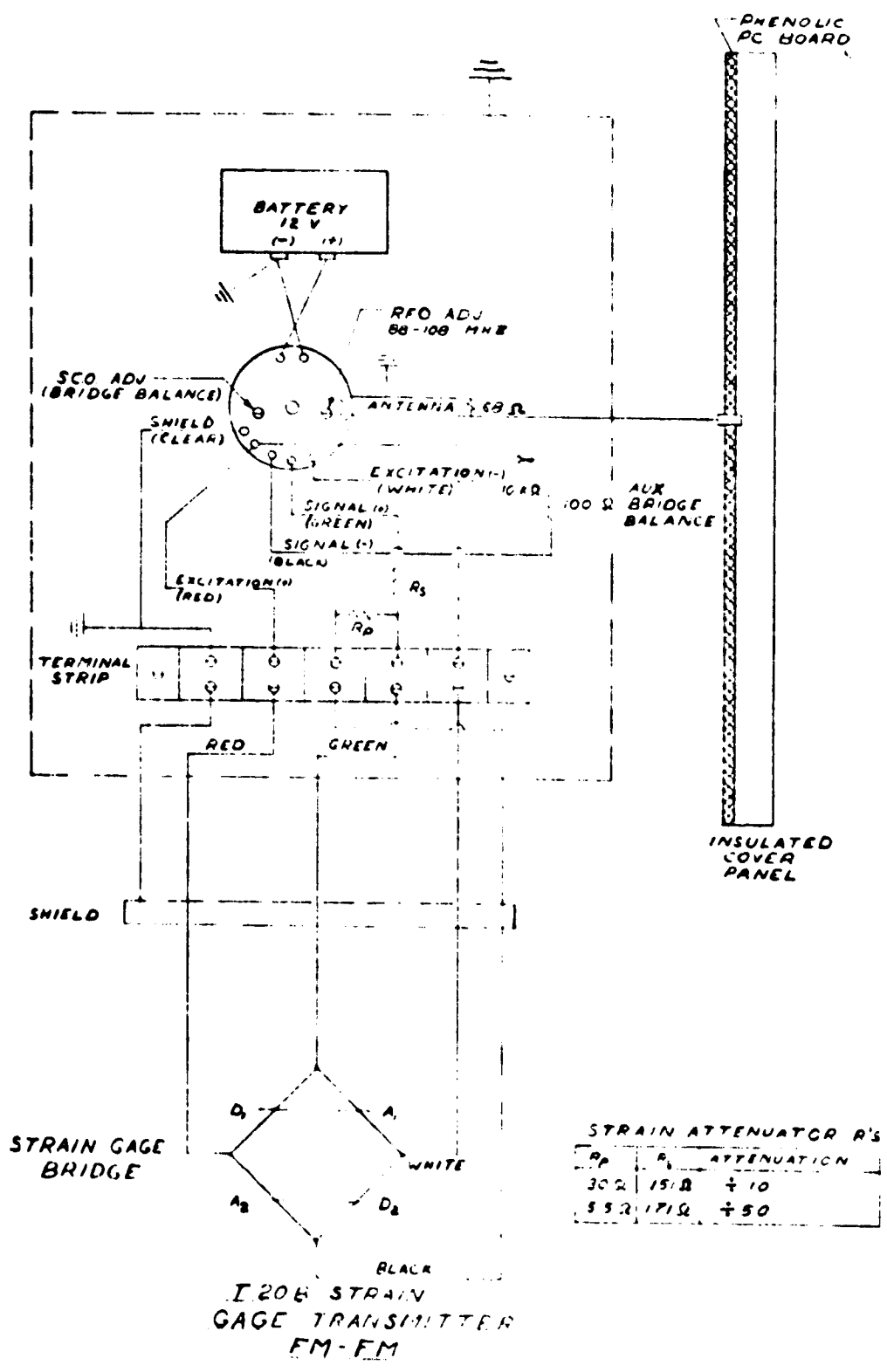

Figure 2-7

The shock accelerometer transmitters were selected to provide broad frequency response (10 Hz to 90 KHz) and compatibility with the Model 4344 Bruel and Kjaer accelerometers. A selectable gain feature was added so that the level of response could be adjusted in the mine to suit sensor output levels. Nominal accelerometer output is 3.3 mv/G, so gains were chosen to permit full scale input levels of 333 G's pk, 1000 G's pk, and 3000 G's pk by selecting the proper transmitter jumper pins.

In order to minimize RF interference and noise problems, significant care was put into transmitter ground and lead wire hookup configurations. Initial tests with both FM-FM and FM transmitters powered by the same battery produced as much as 500 mv of SCO frequency carryover from the strain transmitter to the accelerometer transmitter. The addition of twisted pair power leads to each transmitter reduced cross-talk to less than 40 mv, an acceptable level. Initial tests without separate low side (-) battery grounding and without antenna ground produced a shift in RF center frequency which depended upon structural mounting conditions. Increased metal mass from welded attachment seemed to change the antenna loading and thus move the transmitting frequency. (The output of these transmitters is not buffered so they tend to be affected by changes in output impedance.) Sensitivity to this influence was satisfactorily reduced by proper ground locations.

Battery power required for transmitters is fairly moderate: voltage allowable is from seven volts to 13 volts and current demands are 3.5 ma (millamps) for the acceleration transmitters and 10.5 ma for the strain transmitters. Based upon these loads, a mine-permitted current limited mercury cell battery was designed and ordered from Mallory Battery Co., Number SR-5473, which will power one of each type transmitter for 147 hours. No disconnect switch was used - both transmitters are powered continuously after they are assembled into the transmitting block. Any shutoff would risk an unintentional power interruption from vibration or

abrasive action during the mining process. Figure 2-8 shows the wiring details for the shock accelerometer hookup.

Photos of the transmitter, battery, and antenna mounting are shown as Figure 2-9. Spare transmitters and battery are included along with the two complete mounting assemblies. Visible beside the strain gage terminal strip is the bridge centering trim pot which is tuned after the load cell is attached to the transmitter. In the mine, the acoustic output of the receiver is used to tune in the strain transmitter SCO to the 10,000 to 11,000 Hz range. Increasing bit load decreases SCO frequency.

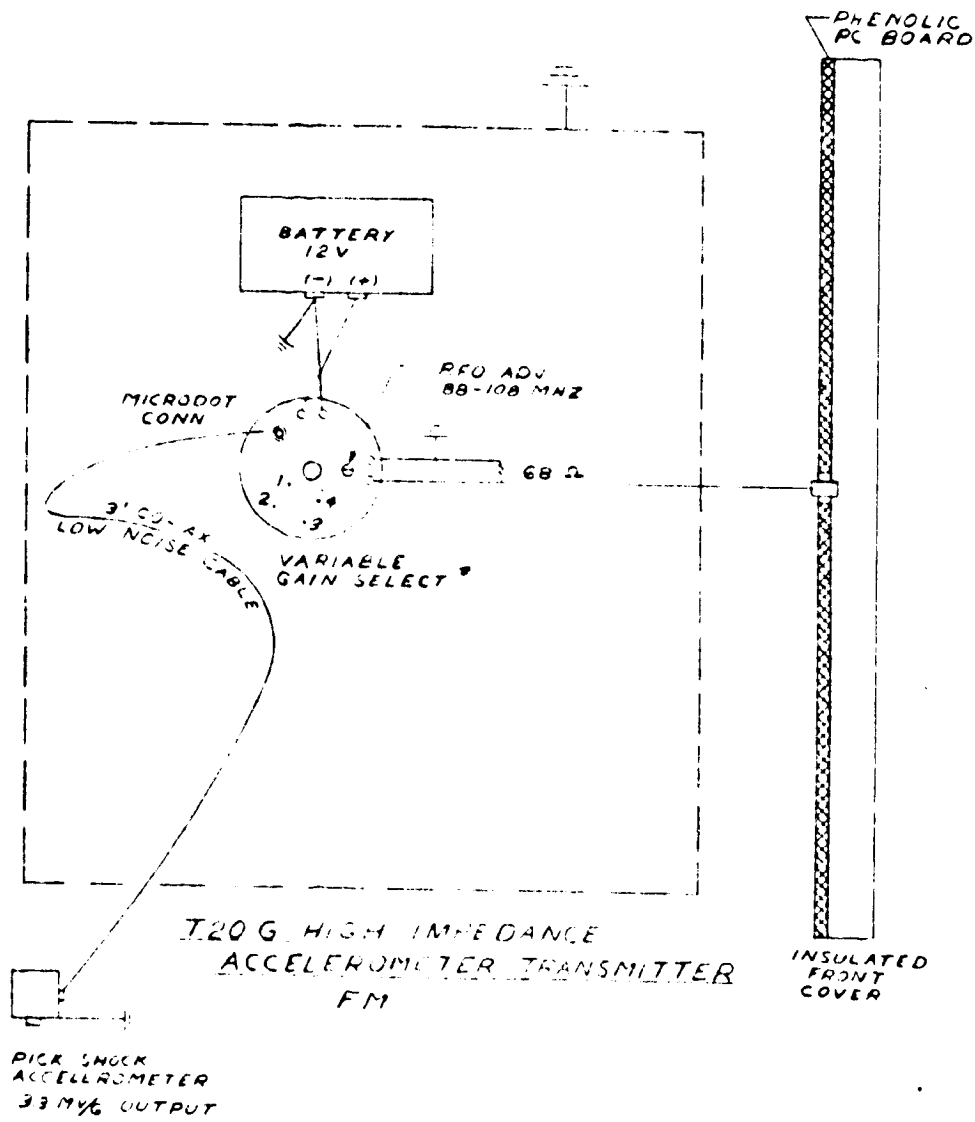

T20 G. HIGH IMPEDANCE
ACCELEROMETER TRANSMITTER
FM

PICK SHOCK
ACCELEROMETER
33 MVA OUTPUT

GAIN SELECT	VOLTS PER G
1-2 HOOKUP	40 MVPP/1G
1 HOOKUP	132 MVPP/1G
1-4 HOOKUP	226 MVPP/1G
AT RECEIVER	50 KHZ CARRIER DEVIATION = 5.

Figure 2-8

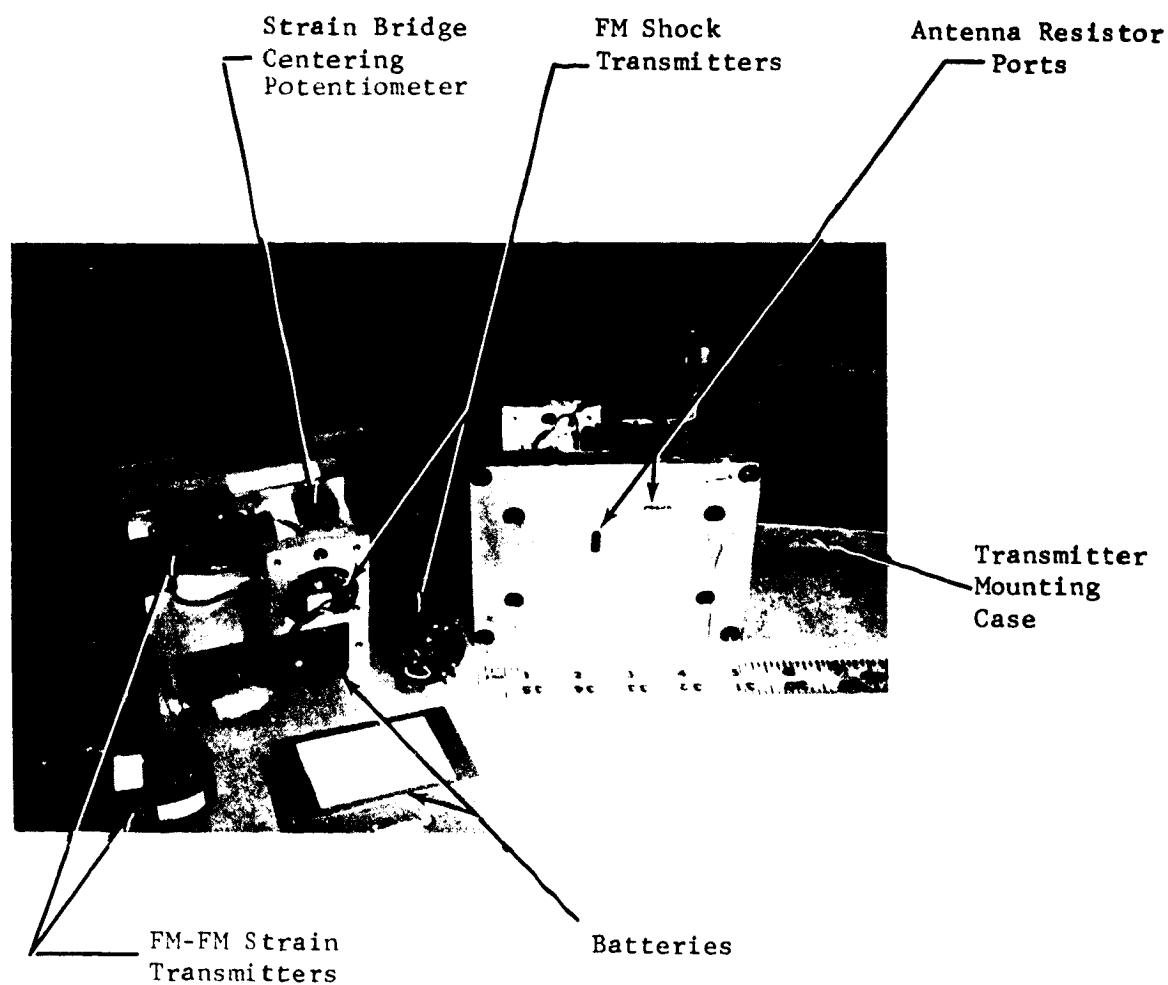

Transmitter Mounting Assembly

Figure 2-9

2.3 Telemetry Receiver Design

The design of a four channel telemetry receiver was influenced by mine test experience which dictated size and weight goals. Since the receiver assembly was to be used generally with a seven channel Lockheed Electronics tape recorder, a low profile unit was preferred to permit mounting on the mining machine chassis in low coal seam height applications. Minimum weight was specified as usually some portion of the trip to the mining machine requires hand carrying of all the test equipment, and single items weighing more than 50 to 60 pounds are difficult to handle, particularly if tunnel height is restricted. The final package shown on Figure 2-9 is 14 inches high by 21 inches wide by 14-1/2 inches deep and weighs 53 pounds in traveling configuration. Figure 2-10 shows the telemetry receiver on its shock mount along side the mine tape recorder.

The FM and FM-FM receivers built into this assembly are from Inmet, Inc. and are modified versions of standard production designs. Each was ordered for DC operation only so AC line transformers were left out. It was found that the DC-DC conversion electronics provided by Inmet could not pass MESA intrinsic safety requirements so a previously permitted modular voltage converter from Semiconductor Circuits, Inc. was substituted for the Inmet circuit of each receiver. Figure 2-11 shows an Inmet receiver with the removed circuit card and the modular converter in place. This receiver modification required a basic change to the receiver battery pack as the original design used 12 volt batteries with solid state current limiting for intrinsic safety. The revised design required 4.5 to 5.5 volts. A separate six volt GelCel^(R) battery with resistance current limiting powers each receiver and provides up to seven hours of operation before recharge is required. The four batteries are mounted in an aluminum chassis with the wire wound current limiting resistors, under a protective cover. Each battery has two 50 watt, one ohm resistors in parallel which are series wired to two additional 50 watt, one ohm parallel resistors. This gives the required one half ohm 100 watt power dissipation capability backed up

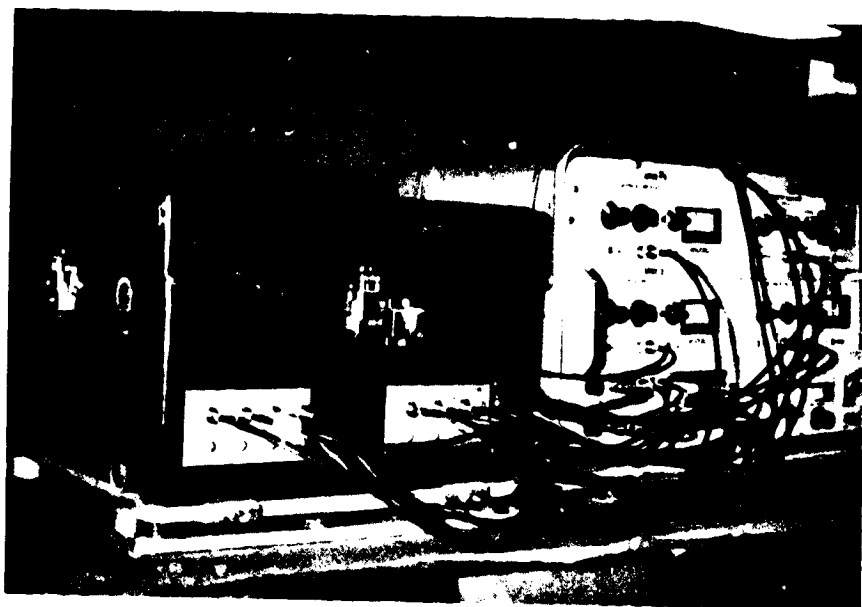

Tape Recorder and Mine Telemetry Receiver

Figure 2-10

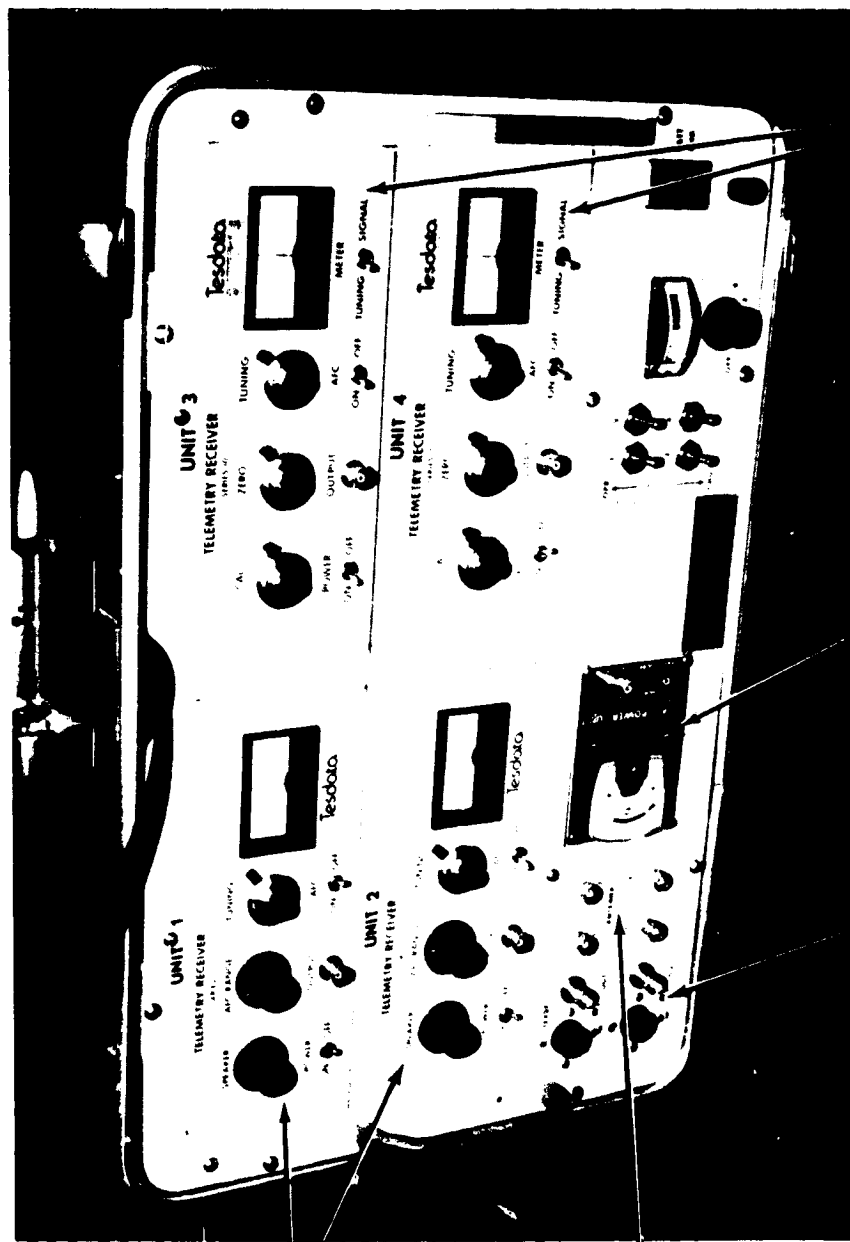

FM Receivers (2 each)

Antenna Hookup

Speed/Phase Marker Hookup

Accelerometer Power Supply

FM-FM Receivers (2 each)

Mine Telemetry Receiver

Figure 2-11

by an equivalent redundant current limiter with complete fail-safe capability. In no way can greater than twelve amps be liberated at six volts so an incintary spark cannot be generated. (Tests have shown that more than 15 amps are required to ignite a methane/air mixture at six volts, so if less current than that is available, the system is safe for gassey mine use.) Figure 2-12 shows the battery installation. The complete battery/resistor assembly is potted to insure that electrical integrity is maintained. The assembly is mounted to the bottom of the sheet aluminum enclosure which holds the individual receiver modules and provides RF shielding. Any receiver also re-radiates some of the radio frequency energy which it picks up, so shielding is necessary to minimize interference between close proximity equipment.

In addition to providing receiving capability for telemetry signals, the receiver assembly also provides conditioning for several other transducers which permit further definition of mining machine operation. A constant current two milliamp source for powering accelerometer electronics, built by PCB, Inc. was included to permit chassis acceleration recording concurrently with telemetry signals. High frequency ranging arm acceleration, using a Bruel and Kjaer Model 4344 accelerometer and a PCB, Inc. Model 402 voltage follower, can be simultaneously evaluated during sensitized pick interface detection tests. The standard constant current supply battery power system by PCB, Inc. was modified for mine use by including resistance current limiting to meet intrinsic safety requirements. Low frequency high output accelerometers previously permitted under Permit #338 can also be powered by this device.

Also included in the receiver assembly is an additional 12 volt battery source for powering two industrial proximity switches which can be used to produce speed or phase signals for sensor development. Figure 2-13 shows the Electro Products Model 55505 transducer mounted in a steel holder for attachment to the mining machine. The 1-1/2 inch (3.8 cm) diameter by 1-5/8 inch (4.1 cm) transducer will detect the presence of

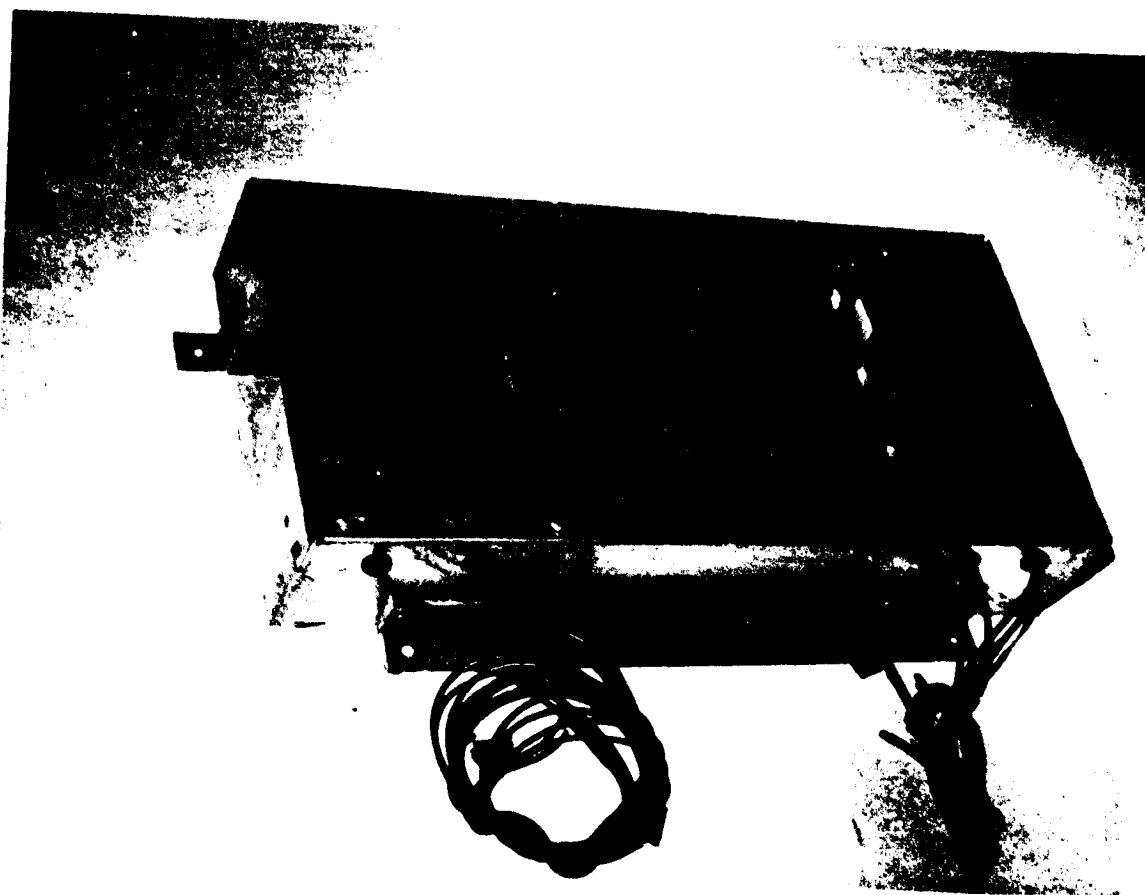

Receiver Battery Assembly
Figure 2-12

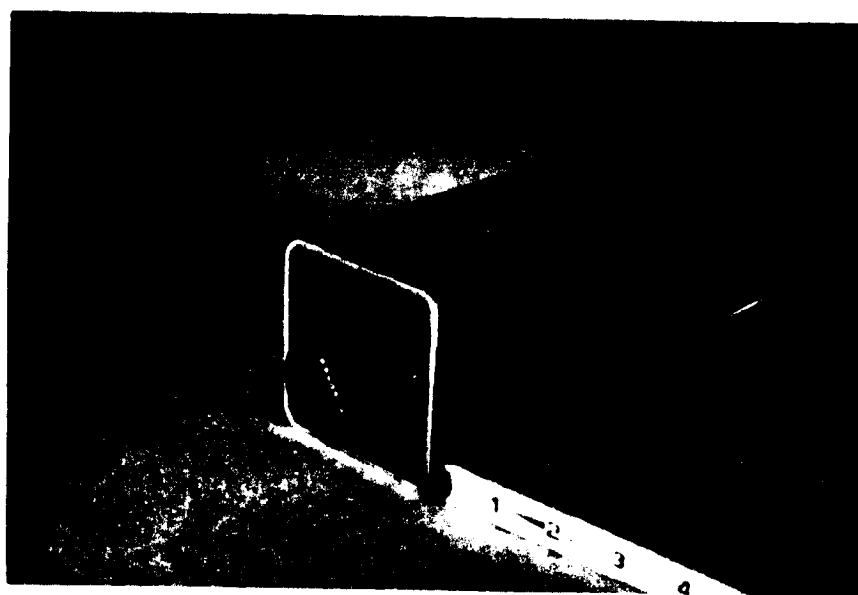

Figure 2-13
Speed/Phase Transducer

steel at up to 5/8 inch (1.6 cm) gap. Installation of this proximity switch next to a passing projection on the mining machine drum or facing the drive rack on the face conveyor will give an output voltage signal related to drum angular position or chassis traverse speed. These signals can be recorded directly on magnetic tape without further conditioning to identify mining machine operation. (A resistance voltage divider circuit is built into the transducer cable to drop the nominal 10 volt output voltage to approximately one volt when metal is detected. This level is compatible with normal tape recorder FM input signals.) The epoxy potting material which encapsulates the transducer electronics is impervious to moisture and provides good abrasion and shock resistance for the mine environment.

2.4 MESA Permission

Electronics components for underground coal mine usage are either approved or permitted under MESA (now MSHA) requirements. Components which might release sufficient energy to cause ignition of a flammable mixture of methane or natural gas and air are reviewed carefully for hazard potential and, if necessary, tested using a rubbing wire brush and rotating cadmium wheel in an ideal gas/air mixture with full battery voltage shorted across the brush/wheel contact. A failing system will ignite the gas in less than 1000 revolutions of the rotating wheel. The data system put together under Contract NAS8-31668 was permitted under MESA Permit No. 338, and it was determined that the additional electronics components for the sensitized pick telemetry system could best be reviewed by requesting an extension of that permit to cover these items. The new complete data package (original and new) was identified as the Shaker Research Corporation SR100 Data System, and was given MSHA Permit No. 338A. Included Figure 2-14 shows the individual items which make up the system. A sticker is attached to each major component noting that mine use is allowed under Permit No. 338A.

2.5 State of Pennsylvania Permission

The State of Pennsylvania Office of Deep Mine Safety requires inspection and

SENSITIZED PICK TELEMETRY

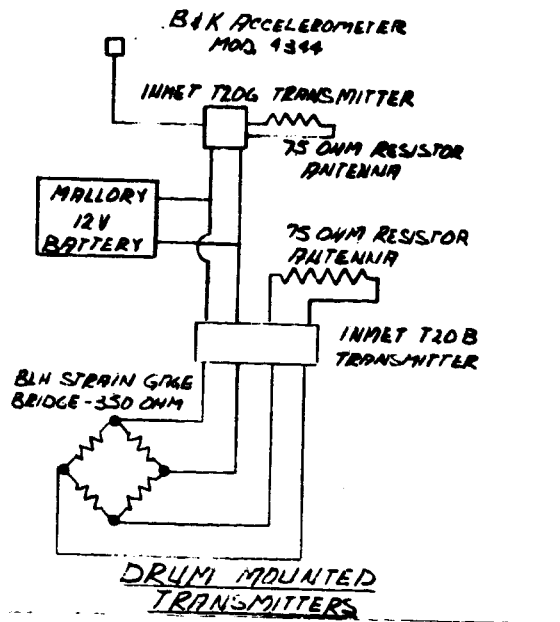

WHIP ANTENNAS (4)

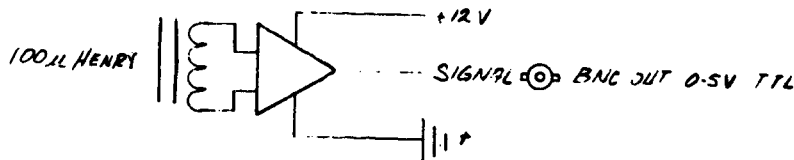
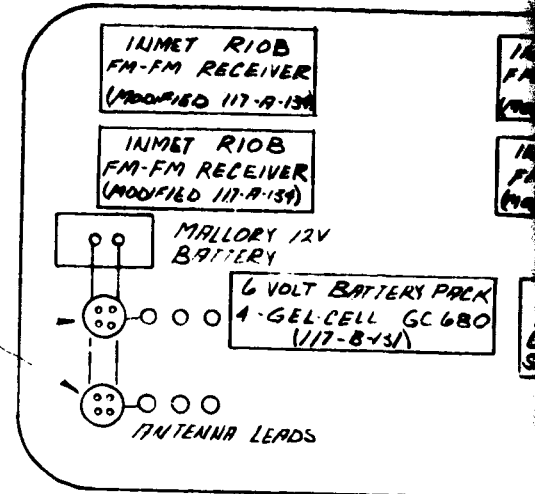
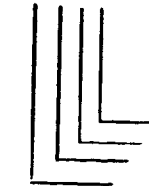

SPEED & PHASE MARKER
ELECTRO CORP. PROXIMITY SWITCH

SHOOKER RESEARCH CORP.
x 10 AMPLIFIER
DWG. NO 117-A-130
MOD. EN211 AMPLIFIER ASSEMBLY ENG
MOD. EN217 AMPLIFIER ASSEMBLY ENG

ADDITIONAL TEST COMPONENTS
PCB INC MODEL 308 R II ACCELEROMETER

NATIONAL SEMICONDUCTOR PRESSURE TRANSDUCER MODEL LX 1960 R (0-3000 PSI)

DANA MULTIMETER MODEL 2100 APPROVAL NO. 26 2084

B&K MODEL 2203 SLM APPROVAL NO 26 2329

B&K MODEL 4230 CALIBRATOR APPROVAL NO 26 2290

LOCKHEED ELECTRONICS 417D RECORDER

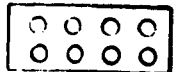
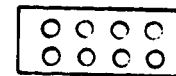

FILE UNIT NAME 1

TELEMETRY SYSTEM

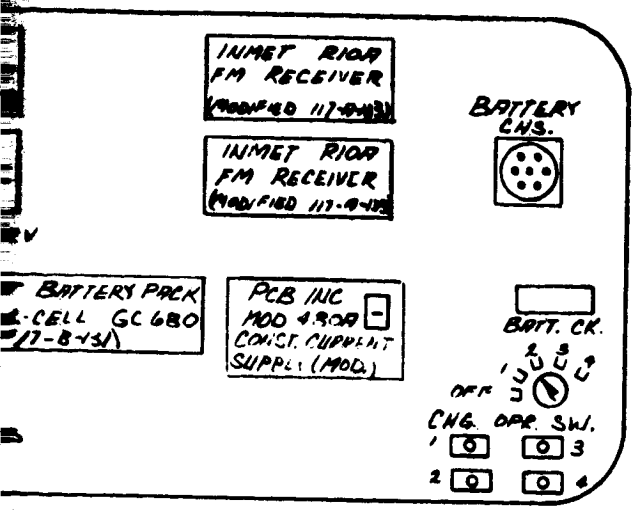

MALDRY BATTERY DETAIL

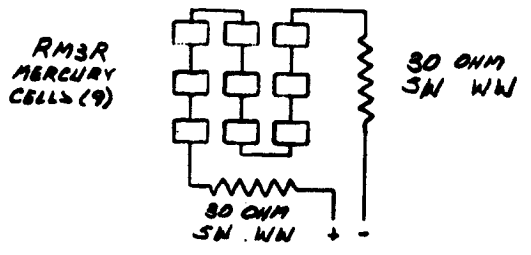

Corp.

ASSEMBLY ENCORE ELECTRONICS

ASSEMBLY ENCORE ELECTRONICS

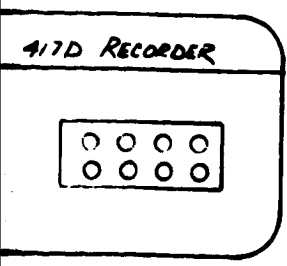
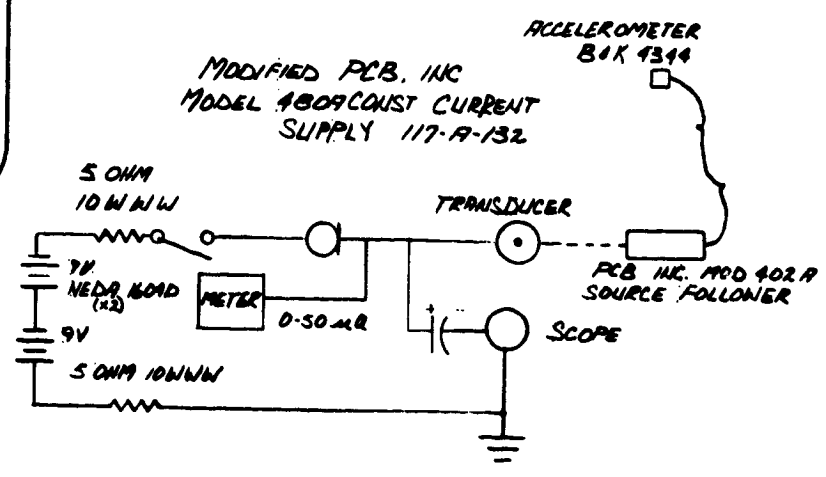

<p>STANDARD TOLERANCES UNLESS OTHERWISE SPECIFIED</p>		<p>SHAKER RESEARCH CORPORATION</p>	
<p>J. KRALICK</p> <p>R. Burchett</p>		<p>MODEL NO. SR 100</p> <p>MINE TEST SYSTEM</p> <p>BLOCK DIAGRAM</p>	
<p>SCALE</p>		<p>DRAWING NUMBER</p> <p>117-B-129</p>	
<p>DATE</p>		<p>REV.</p>	

Figure 2-14

FOLDOUT FRAME 2

approval of potentially hazardous equipment for mine use, and the Shaker Research Corporation SR100 Data System was reviewed by a committee of mine and electrical inspectors to insure compliance. Because of the very short term usage of these data system components underground, no formal approval number was assigned to the system, but the mine inspectors for Jane mine were kept informed of test dates. The original review of the SR100 Test Data System was conducted by a committee appointed by Mr. Lamont, head of the Greensburg, Pennsylvania Office of Deep Mine Safety and chaired by Mr. Clarence Kelley. After Mr. Kelley retired, Mr. Jesse Bolen took over responsibility for review of in-mine test installation.

3.0 MINE SIMULATION TESTING

As a portion of a project to produce and apply a data system for mine measurement and tape recording of sensitized pick coal interface detector output, a test simulation was planned at the above-ground longwall coal mining installation of the Bureau of Mines at Bruceton Station, Pennsylvania. The test simulation goal was to evaluate data output characteristics of telemetry transmitters and other test devices specifically designed for mine use in the electronic and structural environment of an operating mining machine. The Bruceton installation provides a unique opportunity to perform such tests in a realistic test situation without the access, safety, and permissibility restrictions of underground installations. In addition to providing equipment test simulation, this program phase provided an excellent "dress rehearsal" of the underground installation and test.

The equipment selected to relay pick cutting load and shock from the rotating drum to the mining chassis included an FM-FM strain transmitter which broadcasts static and dynamic loads from a bit-shank-contacting strain gage load cell, and an FM high input impedance transmitter for broadcasting output signals from a bit accelerometer. The transmitter/receiver is tuned to a standard FM radio transmission band in the range of 88 MHz to 108 MHz (MegaHertz). Self-contained batteries power the transmitter and receiver to allow operation without external electrical power.

In addition to drum transmission data, the receiver assembly also provides capability of conditioning several additional test parameter outputs for more complete definition of machine performance. Provision is available for powering a chassis-mounted accelerometer for direct measurement of structural vibration, and two speed or phase marker transducers for drum angular position detection and machine tram rate measurement.

The outputs of all transducer conditioners are normally directed to a Lockheed Model 417D tape recorder for permanent record of tests results. This seven channel unit also is battery powered for self-contained operation. All components of the system are MESA permitted for gassey mine use under Permit No. 338A.

3.1 Test Installation

To perform a reasonable simulation test with minimum machine modification, only one sensitized pick assembly was installed on the right-hand drum of the Bruceon Joy longwall miner. A shadow pick block was added to the standard drum lacing pattern, a transmitter mounting case welded to the drum web behind the last bit block, and a connecting lead wire conduit welded between the block and case as shown in Figure 3-1. The bit block and transmitter case were reinforced with diagonal braces to the drum structure as shown in Figure 3-2. These welded-on components accept pick load and shock sensors, and one each telemetry transmitters for strain gage load cell and shock accelerometer.

In addition to the sensitized pick CID equipment, a drum phase angle indicator and a chassis shock accelerometer were installed to evaluate these components of the mine test system. An Electro-Products proximity switch was mounted on the cowl arm to detect the passing of the transmitter case cover so that pick angular location is identified. Ranging arm shock has been identified as an indicator of the seam material being cut so a high frequency accelerometer was attached to the chassis in hopes of correlating CID outputs. Figure 3-3 shows the mounting of these additional instruments.

Gob Side

Face Side

Shadow
Pick
Block

Lead
Wire
Conduit

Right Hand Drum

Transmitter Case

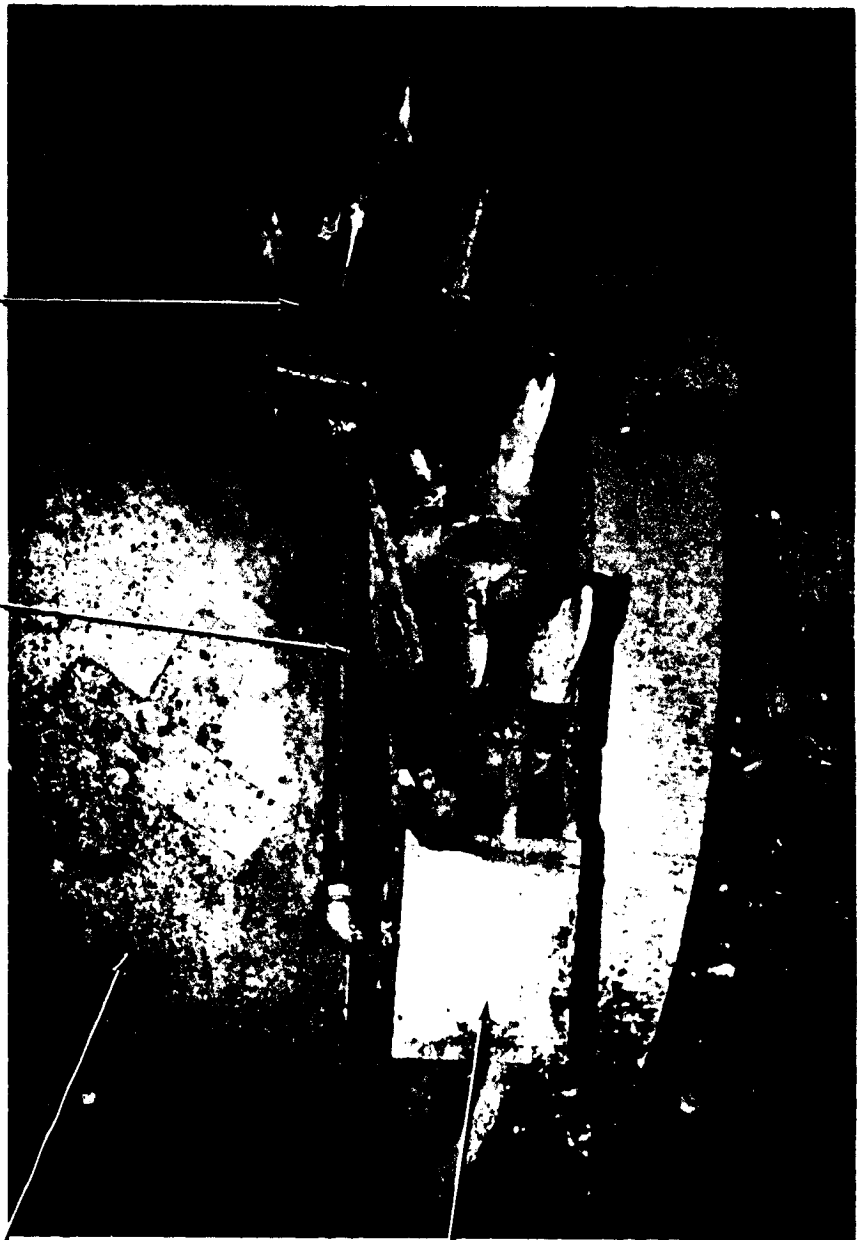

Shadow Pick Installation

Figure 3-1

Shadow Pick Block

Transmitter Case



Welding Reinforcement
Shadow Pick Installation

Figure 3-2

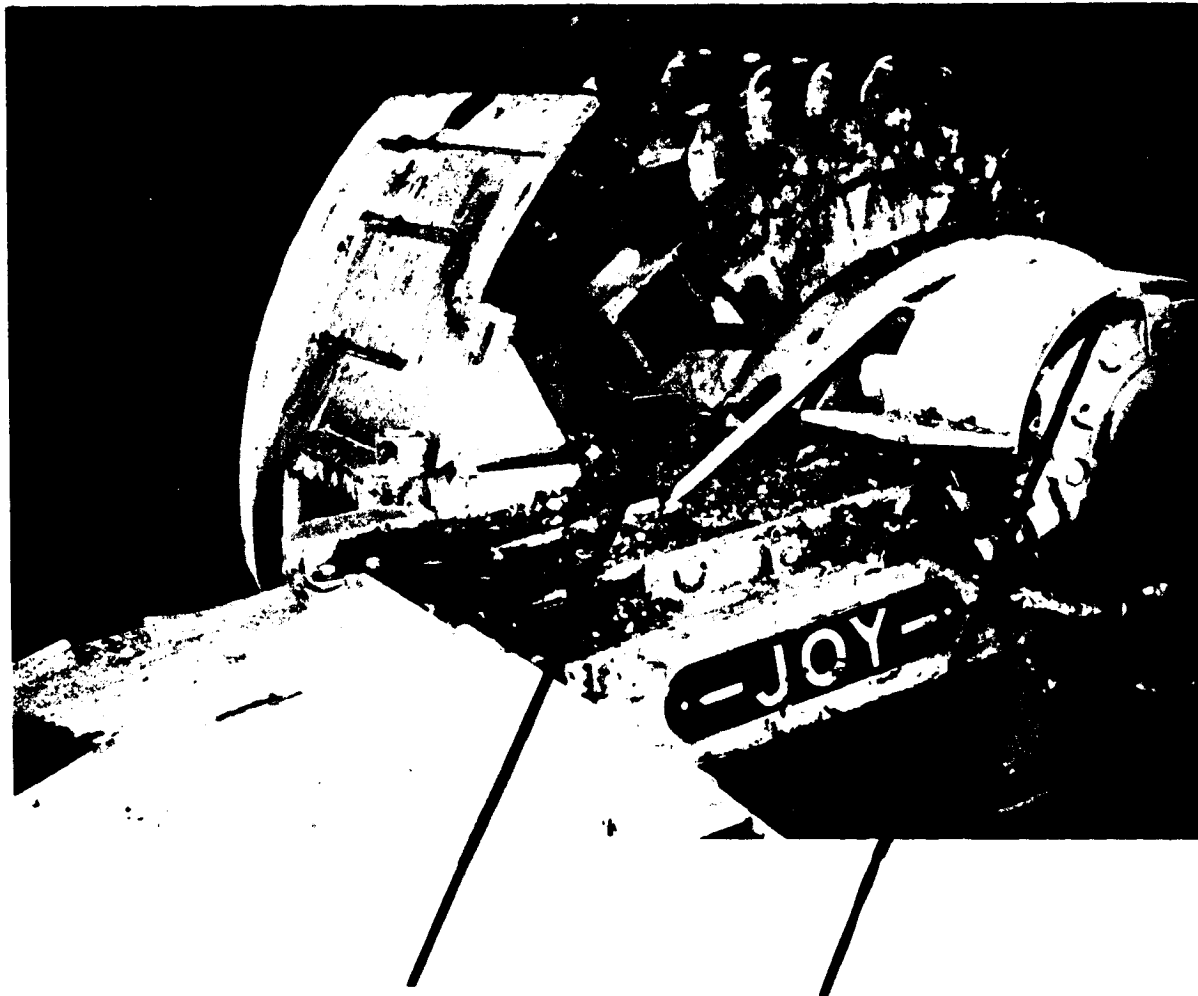

Drum Phase
Sensor Mount

Ranging Arm
Chassis
Accelerometer

Mining Machine Instrumentation

Figure 3-3

3.2 Test Results

The purpose of the Bruceton facility test was to provide test information about instrument system performance rather than mining machine performance. On that basis, the tests were very successful as a number of problems were identified which would have minimized underground test usefulness. Test performance will be reviewed for each portion of the instrument package.

3.2.1 FM-FM Strain Transmitter

Pick load data transmission was accomplished with reasonable success but with more transmitter interference than expected from bench tests. The combination of welded-on transmitter case and bit block along with drum mass gave a somewhat different transmitter loading than was experienced with individual system components connected by grounding clip leads. A significant part of this material influence comes from the method of antenna mounting selected for this application as the radiation conditions are very much connected with structural strength and abrasion resistance demands of the coal mining activity. The transmitter antenna is made up of a 68 ohm carbon resistor termination which allows the output power to be maximized while avoiding antenna vibration and mechanical damage. These resistors (one for each transmitter) are mounted in two cover grooves which receive the transmitter RF output and then turn the cover into a rugged transmitting antenna. Because the cover need be securely mounted, the antenna characteristics are not fully established until it is bolted to its mating box which has been welded to the mining machine drum.

For this test, it was found that securely bolting the transmitter antenna/cover in place almost completely suppressed strain transmitter output. Several attempts were made to electrically insulate the cover from the base, but installation of the non-insulated bolts seemed key to electromagnetic coupling between cover and box. A temporary attachment using duct tape as electrical insulation permitted a limited amount of coal cutting to further evaluate sensor outputs.

Figure 3.4 shows a sample of the low frequency data output from the strain gage transducer (DC to 30 Hz). The upper trace of force for coal cutting only shows a rather moderate load level of 70 to 150 pounds for the roof portion of the cut cycle, 10 to 20 degrees of cutting arc, while the lower curve loads are from 300 to 450 pounds for the initial portion of the cut. All of these data are for a standard 3" length bit trailing approximately 20 arc degrees behind a standard array bit.

3.2.2 FM Pick Shock Transmitter

The transmitter antenna loading phenomenon described for the FM-FM strain transmitter had an even more pronounced effect upon the FM pick shock accelerometer output. The several attempts to provide an RF insulated cover condition ended up with no signal transmission at all. It was later found that an accelerometer transmitter ground loop existed which in effect re-tuned the broadcast frequency to a band outside the tuning range of the receiver (normally 88 MHz to 108 MHz). Steps have been taken to alleviate this problem (see Section 4.2).

3.2.3 Drum Phase Marker

The drum angular position indicator performed without difficulty and produced the tape recorded signals as shown on Figure 3.1. The test transducer appears rugged enough to survive mining service for both drum phase indications and for mining machine tramming rate measurement by counting either drive rack teeth or haulage chain link passing. Recording of these test signals on a tape recorder FM channel gives a good phase reference at the low repetition rate of either drum rotation or ground speed event passing.

3.2.4 Chassis Acceleration Measurement

The high frequency shock accelerometer mounted on the ranging arm to provide correlation between cutting bit and chassis responses produced no usable data for this test. It was later found that the time constant

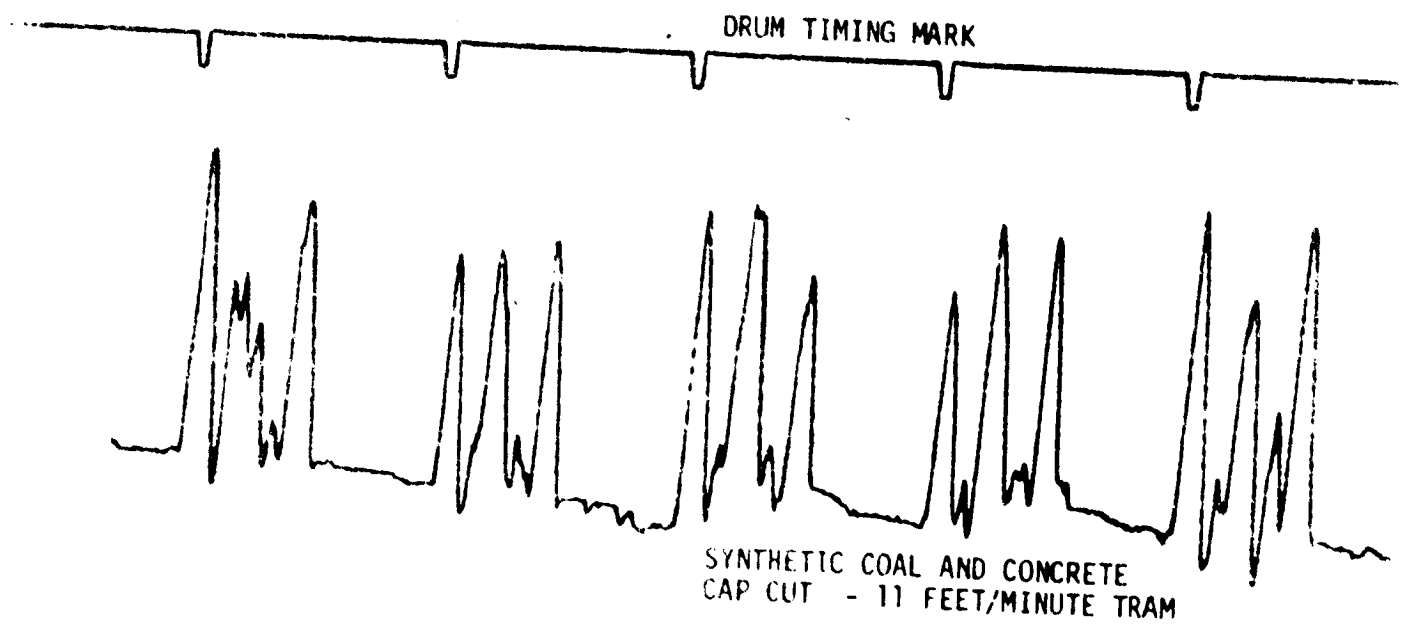
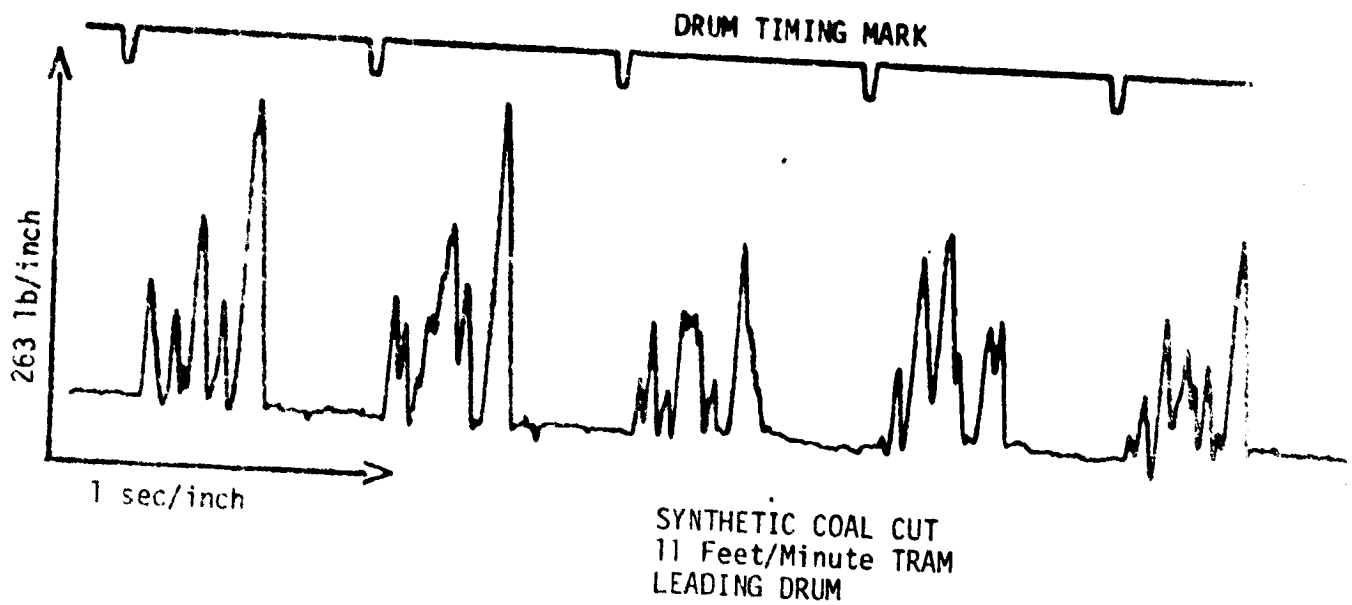

Strain Sensor Output

Figure 3-4

selected for a times ten voltage amplifier added to improve accelerometer signal strength was improper so a large DC voltage build up occurred which saturated the amplifier output. This time constant has been modified so that the problem will not reoccur.

3.2.5 General Installation Notes

It was found that the physical placement of the transmitter box was at a larger radius than desirable so that significant abrasive action occurred as the mounting box rubbed against the concrete cap and against the just-cut synthetic coal. Effect upon this series was minor, but in future installations particular care will be taken to keep the mounting radius below the level of drum bit blocks. If continued sensitized pick tests are conducted on the Bruce-ton machine, relocation of the transmitter block should be considered.

Use of the commercial FM radio transmission band in an above-ground installation caused some additional test interference as local broadcast stations can sometimes overcome the low signal strength available from the data transmitters. The selectable AFC signal seeking control on each receiver could not be used as it would cause the tuner to lock on to the stronger music broadcasts instead of staying with the data channel frequency. This problem can be minimized by returning the data transmitters to bands further from broadcast frequencies and, of course, will be non-existent underground where there are no other competitive stations.

It was also noted that shrouding effects as the drum rotated were greater when the mining machine was standing alone than when the drum was beside the coal block. The signal normally present at the receiving antenna is made up of direct (straight line) and reflected waves, so the presence of additional reflecting surfaces behind the transmitting antennas will improve transmission performance. Mine use should provide suitable reflecting walls nearby to maximize reception.

3.3 Equipment Modification After Test

As a result of the Bruceton test series, a number of changes were made to the mine test system to overcome difficulties experienced. The resulting system has greatly increased test performance potential in underground applications and decreased possible installation difficulties.

3.3.1 FM-FM Strain Transmitter

Laboratory evaluation of simulation test problems for the FM-FM pick load transmitter system showed that transmitter antenna loading influences could be significantly decreased by proper system grounding and lead wire routing. The following changes were made to improve operation:

- A. Shielded four-conductor lead wire was applied instead of four individual conductors from strain gage load cell to transmitter input.
- B. Separate twisted pair leads were installed from battery terminals to each transmitter (FM-FM and FM transmitters are powered by a single current-limited 12 volt battery). This decreased FM-FM sub-carrier interference from 200 mv down to 50 mv or less at the receiver output.
- C. Battery low side terminal was grounded to the mining machine drum.
- D. A voltage-dividing network was added to the strain gage bridge output to reduce load sensor sensitivity. This was deemed necessary as the output of the standard length shadow pick nearly reached the allowable voltage limit for the Lockheed tape recorder, and the other possible configuration proposed will have six to ten times as much load possible. Any of the extended length bits (3-1/4" and 3-1/2" bit lengths are available) or the standard array sensitized pick configurations would undoubtedly produce levels which would saturate signal electronics unless attenuated.

- E. The carrier frequencies for FM-FM and FM transmitters in the same case were adjusted to minimize interference.

The result of these changes was a significant reduction in mounting influence upon signal strength.

3.3.2 FM Pick Shock Transmitter

As with the FM-FM transmitter, the shock accelerometer transmitter performance suffered primarily from ground deficiencies which produced transmitter antenna loading to distort the radio frequency output. Antenna loading influences were minimized by the following steps:

- A. Separate twisted pair leads were installed from battery to each transmitter as indicated in Section 3.3.1.
- B. The battery low side terminal was grounded to the mining machine drum.
- C. The transmitter antenna low side terminal was grounded to the mining machine drum.

During the Bruceton test the only transmitter ground connection was at the shock accelerometer base, and this configuration made the transmitter particularly sensitive to the ground connection between the accelerometer and the transmitter. The ground connection at the accelerometer cannot be avoided because of mechanical construction, so a normally undesirable ground loop (grounding at both ends of a transducer connecting wire pair) is necessary to minimize problems. This is a case where RF transmission problems supersede low frequency data handling concerns.

3.3.3 Chassis Accelerometer Amplifier

The imprudent selection of a very high input impedance for the times ten gain amplifier gave unexpected problems from low frequency (near DC) output from the accelerometer. The charge buildup on the DC

blocking capacitor in the voltage follower output could not bleed off so the amplifier electronics were saturated by excessive DC offset. The cure was the installation of an 18K ohm resistor across the input to ground to allow excess charge to drain off. The reduced input impedance causes no gain error.

4.0 DATA COLLECTION IN AN OPERATING COAL MINE

Section 3.0 of this Report described preliminary testing conducted above ground of a sensitized pick on a Joy longwall miner. Final data to be used for establishing feasibility of using a sensitized pick for detection of coal interface was conducted below ground on an Eichhoff single drum ranging arm shearer. Actual detailed data analysis was not included as part of this contract, but is to be conducted by NASA personnel. Therefore, only a preliminary review was conducted to insure suitability of the data for subsequent analysis. The following paragraphs briefly described the test site, instrument installation, data collection techniques and preliminary data review.

4.1 Mine Selection

The coal mine selected to demonstrate the Sensitized Pick Coal Interface Detector concept was the Jane mine of Rochester and Pittsburgh Coal Company near Indiana, Pennsylvania. This installation has an Eichhoff Model 170 single drum ranging arm shearer operating in 58" to 60" of coal. The drum diameter is 56" so normally is cutting completely in coal. At the roof, the layer above the coal is a high (80%) ash material called "blackjack" which is normally not mined as it reduces the BTU's per ton of product. The output of this mine goes right to the power plant so careful mining directly improves the quality of delivered coal. The blackjack layer is 4" to 8" thick and has a white shale layer above it. The floor normally is firm. Roof control has been a problem in some portions of the Jane longwall panels as faults have caused some significant falls and interruptions in production. This test series was delayed by a roof fall which buried a number of chocks and pan line sections and forced a relocation of the longwall. The management of the Rochester and Pittsburgh Coal Company was most patient and tolerant of the efforts of Shaker Research Corporation to accomplish the mine test portion of this contract. The mere presence of extra people underground requires significant effort from those whose full time job is to mine coal. As much as was possible, test personnel avoided situations which would burden the mining crews with added work or would seriously hamper production. The excellent cooperation of all mine personnel was most appreciated.

4.2 Test Installation - Jane Mine

The initial equipment installation was made at the Jane mine during miners' vacation with the assistance of a regular crew longwall mechanic. Two sensitized pick instrumentation bit blocks were welded to the shearer drum to provide test evaluations of cutting bit load and shock. One standard cutting bit block was removed from the drum and a sensitized pick block installed in its place, and 180° around from that block a trailing block was installed to evaluate the shadow pick concept. A steel transmitter box was mounted behind each sensitized pick block in a protected position near the hub of the drum, and a conduit welded in-between block and box to contain the connecting lead wires. All welding was done without electronics in place. Figure 2.5 shows a layout of the trailing pick concept as installed at the above-ground longwall demonstration site of the Bureau of Mines at Bruceston, the same arrangement was used but for a right-hand drum. The standard in-line bit block installation is shown on Figure 2.4. One shift was sufficient to complete required welding.

During preparations for mining machine vibration testing (Contract Number NAS8-31558), this shearer was equipped with an instrument mounting container which was an open-sided steel box cantilever mounted off the rear end of the mining machine, out over the face conveyor. Because of a ceiling cave-in at Jane mine, the testing for the earlier contract was conducted in a West Virginia mine, but the mounting hardware and the enclosing box were stored above ground so that they were available for containing the tape recorder and telemetry receiver for this test series. The 56" high coal seam at Jane limits the vertical space between the shearer and the chocks to as little as 6" to 8". The end mounted box permits the installation of an instrument up to 21" tall while decreasing the minimum machine vertical clearance by only 4", the amount the box extends above the shearer. The open side permits equipment access during test for adjustment, while the instruments are relatively protected from falling debris. Air flow across this face is from tail to head (right to left when facing the shearer) so dust from the cutting action of the left-hand drum blows away from mounted equipment. A bench photo of this mounting

is shown as Figure 4.1, with the tape recorder shock mount in place.

In addition to the sensitized pick instrumentation outputs, several other transducer responses were tape recorded during shearer operation. An Electro Corporation proximity switch was installed on the ranging arm to detect a drum phase marker attached to the hub. The proximity switch gives a +1 volt DC signal when metal is in front of the sensing end: steel objects within 0.62" (1.6 cm) of the sensor will trigger an output. The phase marker element is a steel plate welded to the cutting drum hub so that it is the nearest metal to the shearer. This plate is angularly located so that the sensitized pick is near top center when the plate passes the proximity switch.

Power for the proximity switch comes from a 12 volt current limited battery in the telemetry receiver. A three wire cable provides signal, power, and ground connections.

A second Electro Corporation proximity switch was mounted to detect passage of the shearer haulage chain links so that shearer speed can be indicated. The sensor was placed so that vertical and horizontal links of the chain gave one complete square wave signal with a period of 5.0": the duty cycle ("on" time versus "off" time) varies somewhat depending upon tension in the chain. The drive sprocket is to the right of the sensor so the chain is taut when the shearer moves left and slack when the shearer trams right with only chain tensioner load on it. Discretion must be used in applying this output for other than average rates of movement.

Two pairs of 30" length whip antennas were used for the four channel telemetry receiver set. An angle bracket was fabricated to hold each pair parallel to the horizon and 4" above the shearer chassis, with one of each pair pointed toward the head end and one pointed toward the tail. One bracket was mounted directly in front of the shearer drum at the gob side of the machine and the other was mounted at the tail end of

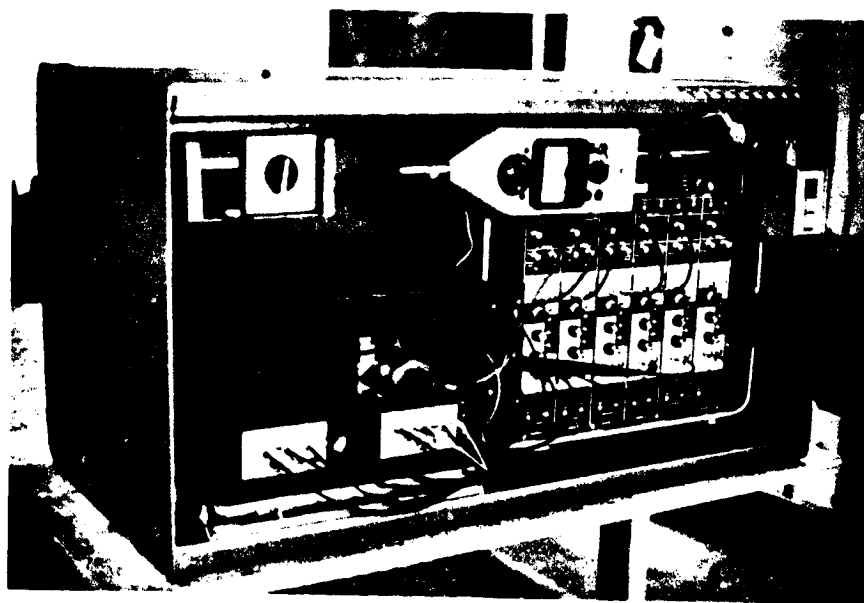
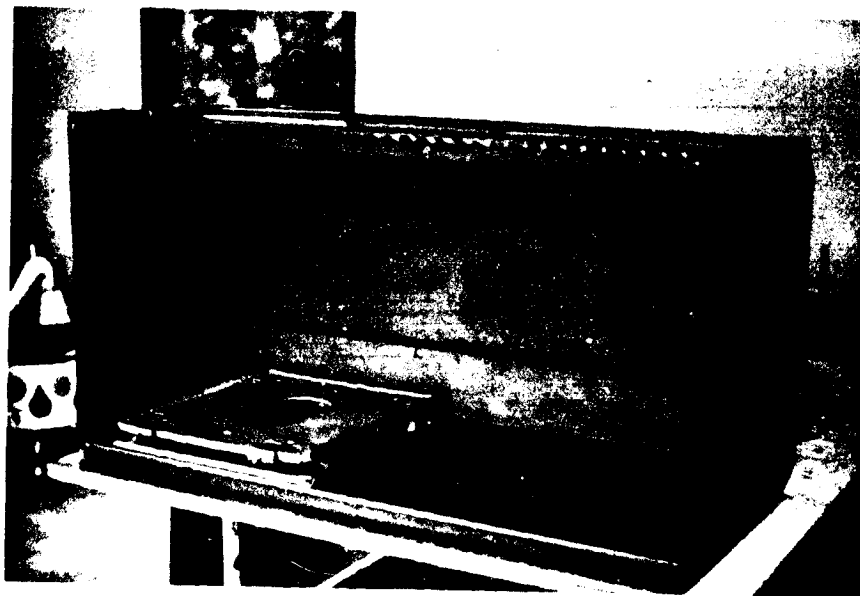

Jane Mine Instrument Box Laboratory View With
Recorder Shock Mount

Figure 4-1

the shearer, right beside the receiver package. These locations were selected to maximize reception, minimize antenna interaction, and avoid infringement upon operator space.

A high frequency (to 40 KHz) miniature B&K Model 4344 accelerometer was mounted on the ranging arm to attempt to monitor cutting action shock during test. These outputs were recorded to provide correlation between sensitized pick output and another output which has been shown to sense the coal interface location. Power for the line driver inserted in the accelerometer connecting lead wire comes from the PCB, Inc. Model 480 source mounted in the telemetry receiver chassis.

The outputs of various transducers were recorded on the Lockheed Model 417D tape recorder prepared for mine testing. Seven tape channels plus a voice track were recorded for above-ground reproduction of test data. Acceleration responses typically were recorded on direct record channels to give response from 100 Hz to 50,000 Hz, while pick load, drum phase, and haulage speed were recorded on FM data channels to give response from DC to 5,000 Hz.

4.3 Mine Test Results

Actual mine testing occurred several weeks later than planned due to unexpected problems. Installation of the sensitized pick cutting bits, both in the trailing "shadow pick" arrangement and in the in-line normal array position, was accomplished in one day shift during miners' vacation on June 27. Management of Jane mine provided a longwall mechanic (a member of one of the regular longwall crews) to burn off one bit block and then weld on the replacement in-line block, the shadow bit block, two transmitter mounting boxes, the connecting conduit between transmitter box and sensitized bit block, and all necessary diagonal braces to provide mechanical strength. The recorder/receiver mounting box was bolted to the rear of the shearer, and a drum phase marker and haulage chain speed sensor mountings were installed.

It was planned that the rest of the test installation would take place during the first shift back after vacation on July 9. The "hoot-owl" shift crew was scheduled to remove the temporary ceiling supports installed to insure face integrity during the outage, so no interruption of scheduled production was envisioned. Two Shaker Research personnel went in with the crew on the man trip and accomplished the installation by 6:00 a.m. At that time, the cleaning operation was through and the shearer was started to begin production. Initiation of the Record mode of the Lockheed recorder caused one of the tape recorder reel drive belts to snap, and as no replacement was at hand, the complete test set-up was removed so that regular production could begin. The welded-on components remained in place on the drum, while the removable mounting hardware was set off in a nearby cross-cut. All electronics were removed from the mine.

The next Saturday the test team returned to the mine to reinstall the test package in preparation for Sunday night tests with the production crew. Unfortunately, the shearer had been left in mid-panel where welding could not be done, which forced a delay until the next week. At this time, the in-line block assembly was intact, but the transmitter box for the trailing pick assembly was gone. Plans were made to return with spare components to restore the drum set-up.

On July 22, 1978, reinstallation was done during a scheduled Saturday idle shift. At this time, it was found that the trailing shadow sensitized pick block had been knocked off along with the transmitter mounting box for the in-line bit block, so it was decided to restore only the complete trailing pick setup as it could be used to evaluate both trailing pick and in-line cutting shock and force. By leaving out the pick ahead of the trailing pick, a reasonable approximation of normal cutting forces can be made. The Shaker Research test crew went in again with the hoot-owl crew on Sunday night. After being delayed by track flooding, reached the face at about 4:00 a.m., and were able to start production by 5:30 a.m. A full face cut was made by 6:30 a.m. (from

head to tail, approximately 350 feet), and it was found that with the instrument mounting box in place the shearer drum could not cut out into the entry. The crew finished the shift drilling the last 3' of the cut for charges to shoot the uncut section. To avoid the hazard of staying alone at the longwall section, the Shaker test crew left the mine and returned with the day shift crew to finish the test and remove all equipment by 11:00 a.m. Within that period, the second panel cut was completed with a variety of cutting bit configurations used for both coal cutting and rock cutting. With one sensitized pick and two transmitters in use, it was possible to improve test reliability by using two receivers and two tape recorder channels for each transmitter output. The tape recorder channels for the second record of each pick sensor output was attenuated so that channel overload possibilities were reduced. The tape recorder inputs were organized as shown on Table 4-1, the Data Tape Log. Two reels of tape were required to complete the two panel cuts, with approximately twenty minutes of actual shearing per panel pass. The drum was ranged up into the hard ceiling several times in each pass to give a good representation of actual mining operation.

Table 4-2 describes the characteristics, output sensitivities and tape channel locations of each of the sensors. Figure 4-2 and Table 4-3 illustrate and describe the locations of the sensitized pick instrumentation.

TABLE 4.1

DATA LOG TAPES

Data Log Tape #209

Tape Channel	Sensor	Tape Gain	Telemetry Receiver	
			Gain	Offset
1 FM	Pick Load #4 Receiver	X1	min.	0
2 Dir	Pick Shock #3 Receiver	X1		
3 FM	Pick Load #2 Receiver	X 1/5	min.	0
4 Dir	Pick Shock #1 Receiver	X 1/13		
5 FM	Drum Phase Marker 1/rev	X1		
6 Dir	Ranging Arm Accel 3.0 mv/G	X1		
7 FM	Haulage Chain Pass - 5" period	X1		
VT	Voice Commentary			

Operation Summary

- A. Initial 1/4 panel standard length trailing pick with lead cut from left to right (head to tail).
- B. Rest of panel to tail - standard length bit without lead pick - standard bit load (nearly)

Data Log Tape #210

Tape Channel	Sensor	Tape Gain	Telemetry Receiver	
			Gain	Offset
1 FM	Pick load - #4 Receiver	X1	min.	-1.0v
2 Dir	Pick Shock #3 Receiver	X1		
3 FM	Pick Load #2 Receiver	X 1/5	min.	-1.0v
4 Dir	Pick Shock #1 Receiver	X 1/13		
5 FM	Drum Phase - not available	X1		
6 Dir	Ranging Arm Accel 3.0 mv/G	X10		
7 FM	Haulage Chain Pass	X1		
VT	Voice Commentary			

- C. 3-1/4" pick trailing a standard bit - full tape traverse from tail to head (right to left)

DETAILED SENSOR DESCRIPTION1. Pick Load (Tape Channels 1 and 3)

Largest diameter load cell bearing on bit shank, preloaded by cap bolt = 0.4VDC = 2100 lb.

Load cell output (direct compression) = 5200 lb/volt.

Load cell output (tip load) = 3333 lb/volt (at receiver output), 3" bit

Load cell output (tip load) = 3075 lb/volt (at receiver output), 3.25" bit

Two compression 350 ohms strain gage + two dummy gages at 90° for compensation.

External attenuator to multiply full scale microstrain.

Transmitter setup to reduce system sensitivity.

156 ohms series resistance, 27 ohms parallel resistance.

Normal F.S. with 4 active arms = \pm 125 μ strain at zero attenuation.

2. Pick Shock (Tape Channels 2 and 4)

B&K Model 4344 accelerometer on pick load button. 3 MV/G nom. output.

44 MVPP/1 KHz Pin 1-2 attenuator hookup.

2.2 V = 366G at input to transmitter.

5.0 V = 366G at receiver output or 73.2 GPK/Volt Pk.

3. Drum Phase Marker (Tape Channel 5)

Electro Corp. Model 55505 proximity switch mounted on ranging arm, detecting passage of a welded-on plate following the pick mounted web. Provides phase indication to mark bit position. Zero volts d.c. for no metal, one volt d.c. when material in front of sensor (up to 0.62 inches clearance between sensor and plate). Sensitized pick at roof when triggered (approximately). Normal 0-10 volt output divided to give 0-1 volt response.

4. Ranging Arm Acceleration (Tape Channel 6)

B&K Model 4344 accelerometer on ranging arm to detect cutting shocks. 3 MV/G output using voltage follower (PCB) to give low impedance to drive tape recorder input. Shaker Research X10 amplifier available to boost output, if needed.

DETAILS OF SENSOR DESCRIPTION

5. Haulage Speed Sense (Chan. Channel 7)

Electro Corp. Model 55505 proximity switch mounted to detect pass of haulage chain links. Period of alternate links equals 5.0 inches, so position and rate of tramping can be detected. Normal 0 to 10 volt output divided to give 0 to 1 volt response.

6. Voice Track

Noise cancelling hand-held microphone for commentary during test. Four foot lead wire between mike and recorder.

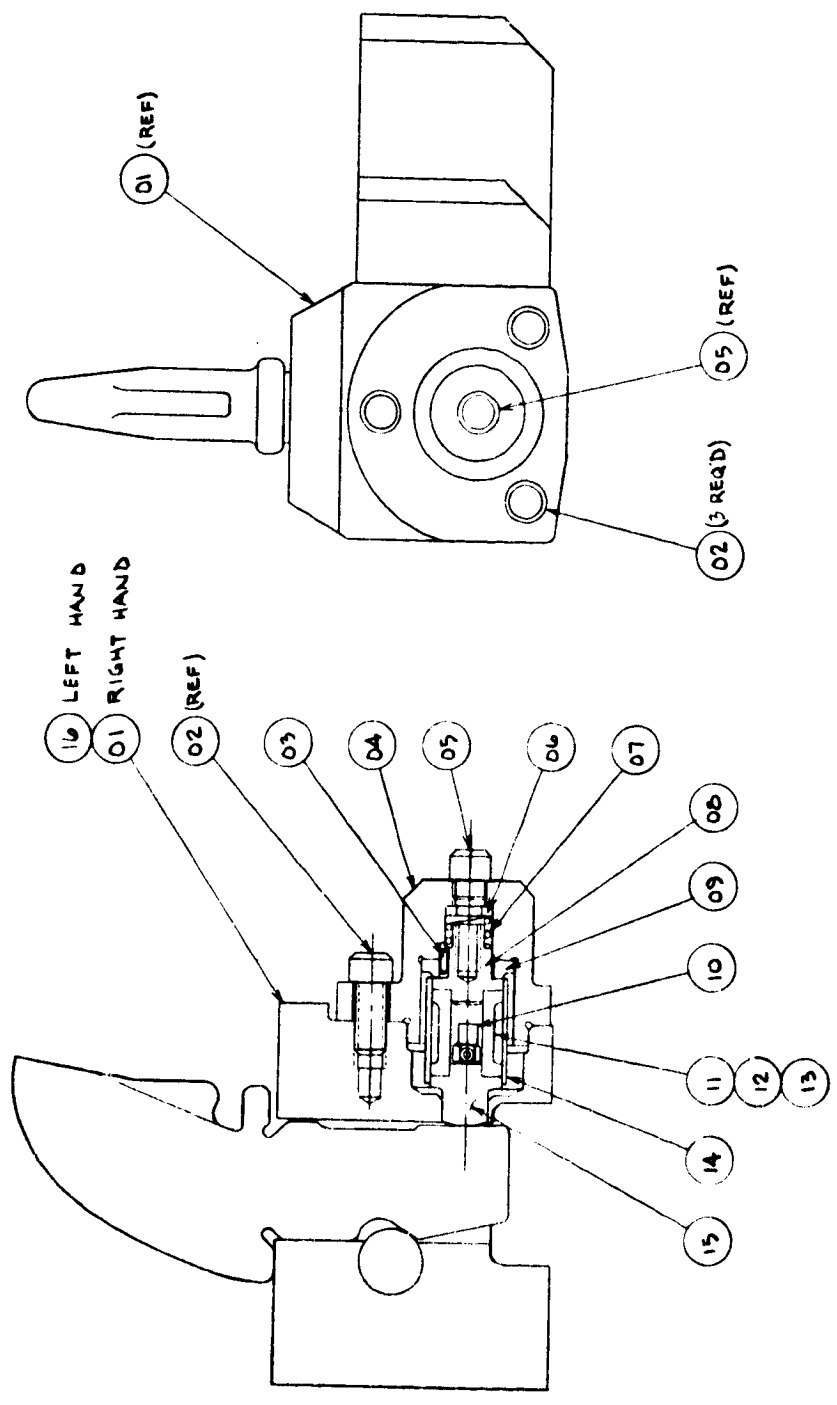

Figure 4-2

Sensitized Pick Instrumentation

		RESEARCH CORPORATION <small>INCORPORATED IN INDEPENDENT PARK BALLING CREEK NEW YORK 10810</small>	
DIMENSIONAL TOLERANCES UNLESS OTHERWISE SPECIFIED IN FRACTIONS 2 PLACES ± .02 3 PLACES ± .005 ANGLES ± .2 BREAK SHARP CORNERS REMOVE ALL BURRS		TITLE ASSEMBLY, INSTRUMENTED PICK	DRAWING NUMBER 117-2-125
SCALE 1/1	SHEET 1/1	OF 1	REV 1/1
DRAWN SWK	CHECKED WLD	7/31/77	7/31/77
ISSUED 1/1	1/1	1/1	1/1

G1 RIGHT HAND

G2 LEFT HAND

TABLE 4-3

SENSITIZED PICK COAL INTERFACE DETECTORPick Load and Shock Detection Components
Drawing No. 117-C-125

- 01 Modified Bit Block (R.H.) 16 (L.H.)
- 02 Retaining Screw-End Cap, 3 each
- 03 Anti-rotation Pin
- 04 End Cap
- 05 Load Cell Preload Screw (Lock Nut Not Shown)
- 06 Hardened Washer
- 07 Preload Spring (Not Used)
- 08 Load Cell Adapter
- 09 Washer - Anti-rotation
- 10 Shock Accelerometer
- 11
- 12 Load Cell - Alternate Diameters with compression and compensating strain gages
- 13
- 14 Protective Sleeve (Not Used)
- 15 Load Cell Contact Adapter (Hardened)

ORIGINAL PAGE IS
OF POOR QUALITY

4.4 Tape Data Review

The detailed analysis of data is to be conducted by NASA Marshall Space Flight Center personnel. A preliminary review of the data was conducted by Shaker Research Corporation to insure adequate signal to noise ratio of all recorded channels. The following discussion and comments are not intended to interpret results but are drawn from a very limited scan of the test data. Some of the recommendations for processing information will have to be viewed as possible techniques rather than as ultimate procedures.

It has been projected that the cutting force on a shearer pick is proportional to the depth of cut of the bit, a somewhat variable value which depends upon drum speed, machine tramming speed, and angular position of the drum. The normal cut depth varies as the Baseline 180° spacing plot shown on Figure 2.6 with the use of a trailing or "shadow" configuration measurement pick minimizes the difference in depth of cut with angular position for extended length bits. For the $1/4$ " extension bit used in this series, the difference between maximum cut and starting cut is less than two to one, while the standard arrangement shows a twenty to one or greater difference between the cutting depth at ceiling or floor and that experienced at the 90° angular position.

In data reduction, confirmation of the shape of these curves is desirable but probably optimistic as the irregular fracture of coal gives rather wide instantaneous variations in depth of cut. However, a brief review of tape recorded responses of pick load shows that the trailing pick with zero extension (standard length bit) gives very moderate load indications, the standard length bit without a lead pick gave very large signal strength indications, and the trailing pick with $1/4$ inch extension gave intermediate load level indications. The general impression gained during analysis was that tape data channel 1 was the better information record as the data in channel 3 appeared to have much more noise and receiver tuning problems.

Two major data analysis techniques were utilized to review load data: low frequency strip chart recording (00 to 125 Hz) and real time spectrum analysis using a Nicolet Scientific PA-500 Spectrum Analyzer. Examples of low frequency response for three transducers are shown on Figure 4.3, which illustrates amplitude versus time plots for the strain gage load cell, the shock accelerometer on the pick, and the haulage chain tram speed indicator. The accelerometer output was envelope detected to define the character of the shock response as the direct record capability does not respond to less than 100 Hz data. This trace shows some interesting variations during the cut cycle.

Figure 4.4 is another time plot which shows the drum phase marker output. This sensor was only available during the first quarter of Tape 209, but it can be used to determine drum speed and as an example of a possible output for a longer term test installation.

An example of spectrum analysis of tape data is shown as Figure 4.5. This trace shows frequency component values of the pick load cell which indicate that much data is present in the frequency range from 1000 to 2000 Hz. It is assumed that some of the discrete components are due to resonance of the pick, and these components may be useful carriers of information about cutting action.

Evaluation of the ranging arm acceleration response recorded in tape channel 6 was very limited and was primarily a visual review of oscilloscope response during various cutting conditions. It appeared that a fair amount of low frequency noise was present with small bursts of high frequency information occurring as cutting shocks take place. These data should be reviewed using narrow band frequency analysis to separate the low and high frequency components.

ORIGINAL PAGE IS
OF POOR QUALITY

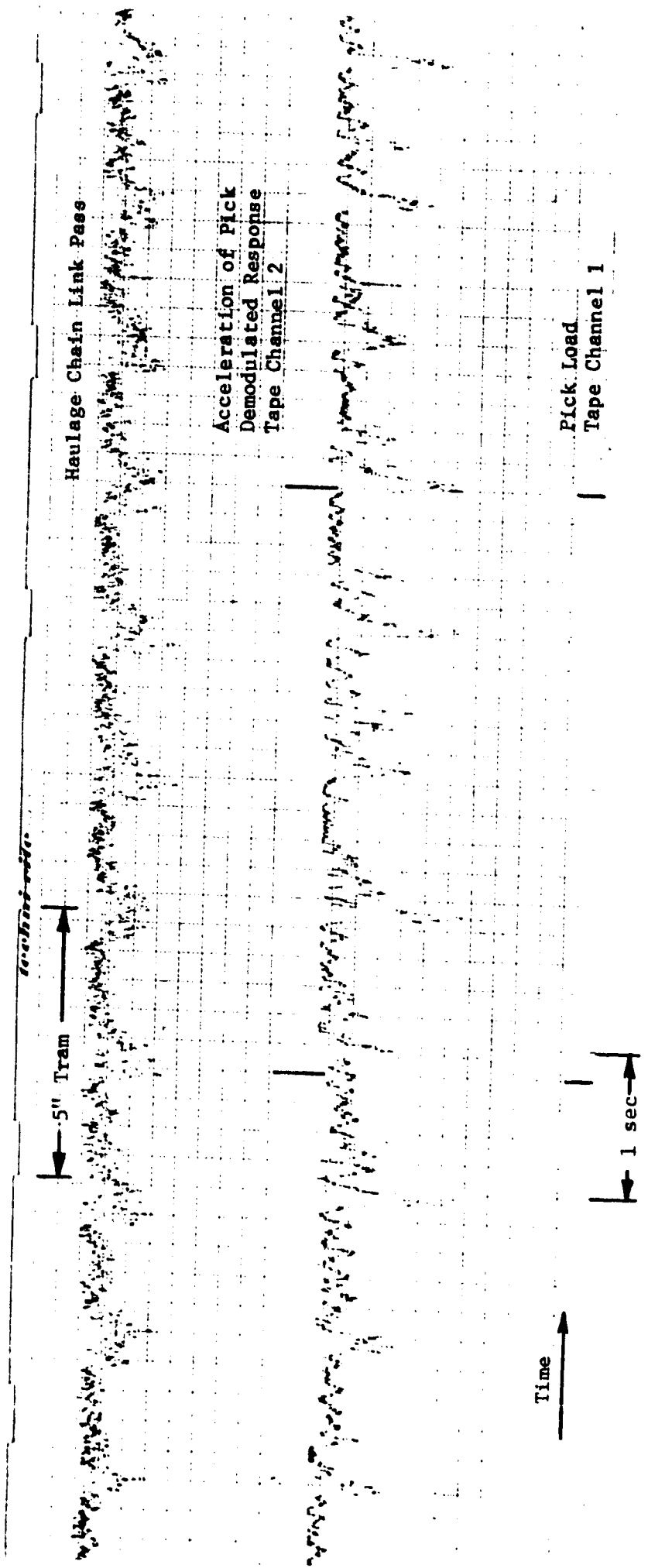

Low Frequency Shadow Pick Test Data 3-1/4" Bit Length
0-125 Hz Recorder Response

Figure 4-3

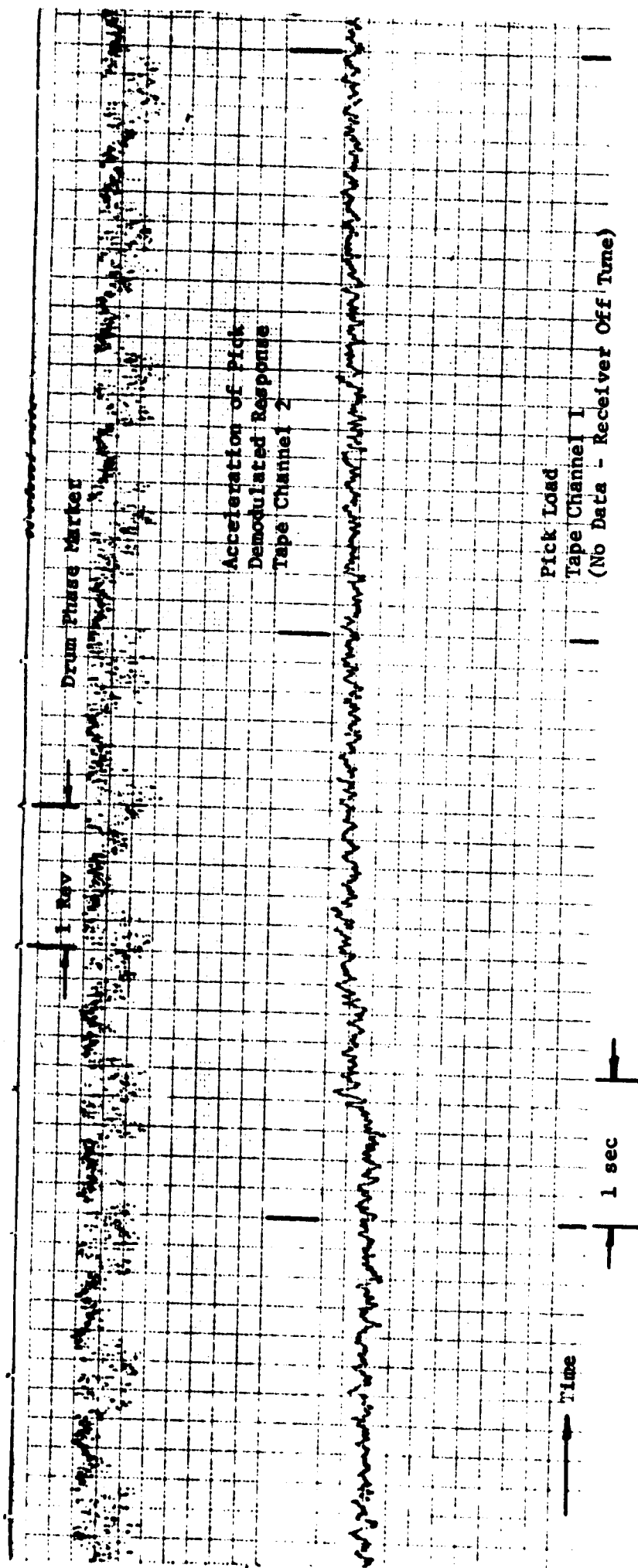

Low Frequency Shadow Pick Test Data 3" Bit Length
0-125 Hz Recorder Response

Figure 4-4

Hz

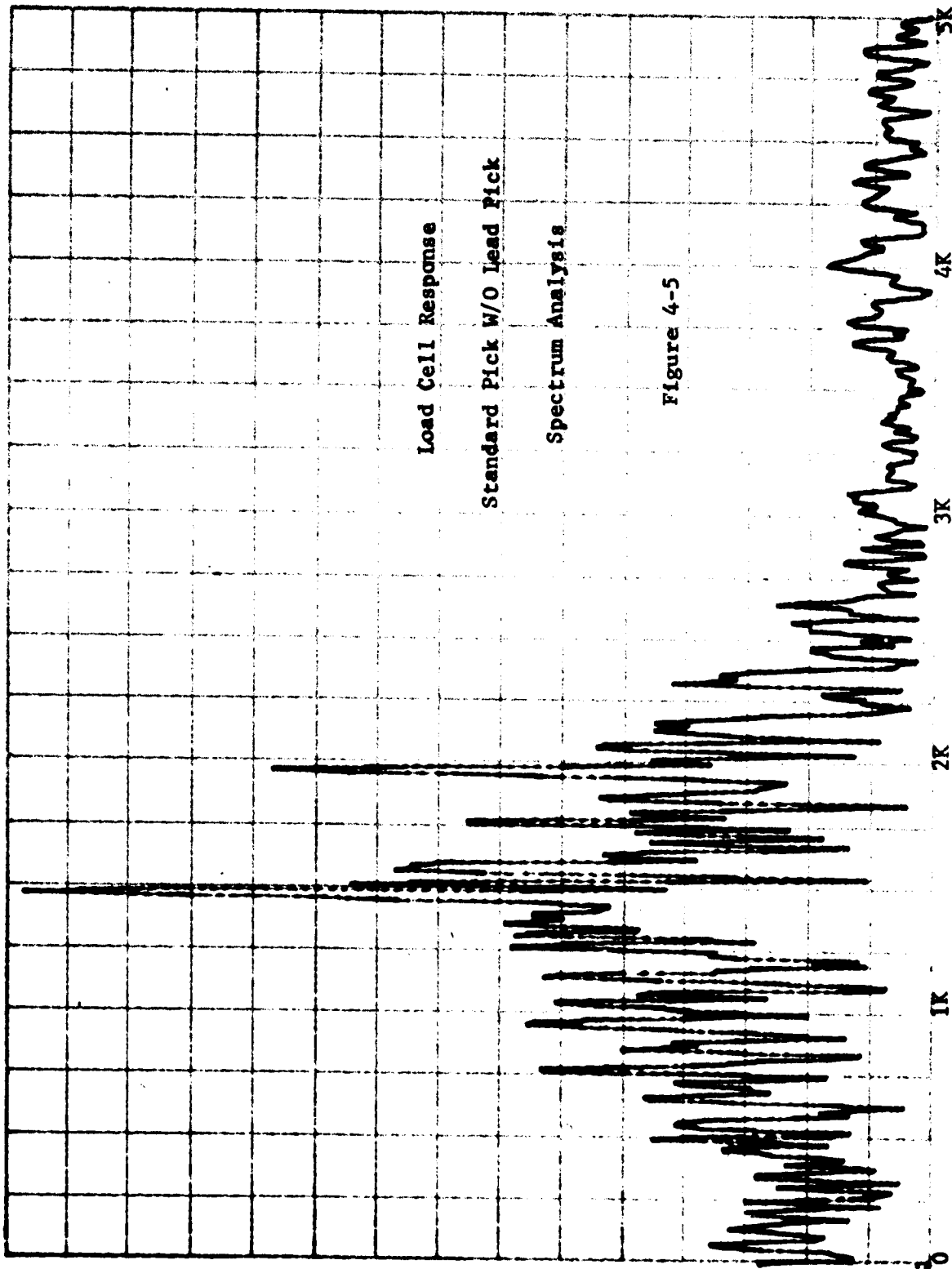

Pick Load -
Pounds

Load Cell Response

Standard Pick W/O Lead Pick

Spectrum Analysis

Figure 4-5

0

1K

2K

3K

4K

5K

Initial review of the data indicates that all record channels appear satisfactorily and are suitable for detailed analysis. Detailed analysis should provide considerable information regarding longwall shearer bit loads and shock information.

Detailed cycle-by-cycle analysis will be required to establish suitability of the instrumentation for detection of the coal-rock interface.

5.0 CONCLUSIONS AND RECOMMENDATIONS

This program to design, build, and test a system to measure and record the cutting action of picks in a longwall shearer drum has resulted in the generation of approximately one hour of multiple channel test data from a variety of transducers and during a variety of machine operating conditions. Based upon a very brief review of these data, both the instrumentation systems and the measurement concepts developed have been adequate to define cutting forces and shocks in normal mine operation of a longwall shearer. The difficult task of analyzing these test data to define control parameters to make use of the sensitized pick coal interface detection technique remain to be accomplished.

It is recommended that a very detailed cycle-by-cycle analysis be done of test data to characterize the response for normal full depth cut, for standard length trailing pick operation, and for extended length trailing pick operation. From this study the preferred pick mounting will be defined for sensitized pick C.I.D. application, and at least a preliminary definition of required data conditioning will result. It is expected that a rather complex algorithm will be needed to compare in-seam coal cutting with coal plus non-combustibles cutting so that factors such as tramping speed, coal hardness and fracturability, seam cleavages, and bit sharpness can be accounted for in determining the location of hard rock or soft clay boundaries.

Based upon the difficulties experienced in obtaining the in-mine test data, it is recommended that further evaluation of any sensitized pick C.I.D. be begun with extended operation above ground to thoroughly "wring out" components at a facility such as the longwall demonstration site at Bruceston Station. The severe test environment, coupled with reduced instrument monitoring capability, makes evaluation of performance underground very difficult. The limited above ground tests conducted in this program made

significant contributions to equipment checkout, but additional operation would have further improved data gathering reliability and would have assisted in evaluation of the basic concept of coal interface detection.

It is further recommended that the application of the sensitized pick C.T.D. concept be initially to produce a coal - clay - rock signal which an experienced operator can use to guide the cutting drum. An indicator system with lights would give an opportunity to evaluate the detection scheme without the demands of machine control logic and absolute fail-safe requirements.

The basic components of the system developed under this contract appear to be suitable for extended above-ground or underground test evaluation of the sensitized pick detection concept. The instrument bit block, transmitters, batteries, and receivers can be repackaged into more rugged cases for continuous application on a working coal mining machine.

ORIGINAL PAGE IS
OF POOR QUALITY