

1482
c.1

NASA Technical Paper 1482

LOAN COPY: RETURN
AFWL TECHNICAL LIBRARY
KIRTLAND AFB, N.M.

0134680



TECH LIBRARY KAFB, NM

Evaluation of a Simplified Gross Thrust Calculation Technique Using Two Prototype F100 Turbofan Engines in an Altitude Facility

Frank J. Kurtenbach

JUNE 1979





NASA Technical Paper 1482

Evaluation of a Simplified Gross
Thrust Calculation Technique
Using Two Prototype F100 Turbofan
Engines in an Altitude Facility

Frank J. Kurtenbach
Dryden Flight Research Center
Edwards, California

NASA

National Aeronautics
and Space Administration

**Scientific and Technical
Information Branch**

1979

EVALUATION OF A SIMPLIFIED GROSS THRUST CALCULATION
TECHNIQUE USING TWO PROTOTYPE F100 TURBOFAN ENGINES IN
AN ALTITUDE FACILITY

Frank J. Kurtenbach
Dryden Flight Research Center

INTRODUCTION

The ability to determine jet engine gross thrust is and will continue to be of major importance in flight testing, since it is related directly to the evaluation of aircraft performance. As the complexity of jet engines has increased, the amount and complexity of the instrumentation, computation, and engine testing necessary to determine thrust have also increased. At present, the gross thrust of modern engines can be determined with an acceptable degree of accuracy only by using complex methods that require extensive instrumentation and engine testing (refs. 1 and 2). The simplified gross thrust model (SGTM) described in reference 3 was developed to attempt to alleviate these problems.

The simplified gross thrust model uses only three pressure measurements in the afterburner duct and a measurement of free-stream static pressure to determine gross thrust. Ideal one-dimensional thermodynamic relationships, which are empirically corrected with test data, are used in conjunction with the four pressure measurements to calculate gross thrust.

The SGTM was evaluated in conjunction with a program to study the propulsion system integration on an F-15 airplane powered by F100-PW-100 engines. The two engines to be used in the subsequent flight program were calibrated for thrust and airflow in the NASA Lewis Research Center Propulsion Systems Laboratory.

Reference 2 compares the facility measurements of thrust and airflow with the engine manufacturer's engine model predictions and provides the corrections necessary to calibrate the engine model.

This report compares the SGTM-calculated thrust with the facility-measured thrust and also compares the simplified model with the engine manufacturer's calibrated gas generator model (GGM).

SYMBOLS AND ABBREVIATIONS

A	area, m^2
C_D	nozzle discharge coefficient
C_V	nozzle velocity coefficient
E	SGTM empirical coefficient
EEC	engine electronic control
EPR	engine pressure ratio
F_G	gross thrust, kN
FIGV	fan inlet guide vane angle, deg
f()	functional relationship
GGM	gas generator model
K_1	SGTM empirical coefficient
K_2	SGTM empirical coefficient
M	Mach number
N_{fan}	fan rotation speed, rpm
PR	pressure ratio
p	static pressure, N/cm^2
p_t	total pressure, N/cm^2
RNI	Reynolds number index, $\delta/\theta^{1.24}$
SGTM	simplified gross thrust model
T	temperature, K

UFC	unified fuel control
W	mass flow , kg/sec
W_{fp}	primary (gas generator) fuel flow , kg/hr
W_{ft}	total (primary plus afterburner) fuel flow , kg/hr
x	= γM^2
γ	ratio of specific heats
δ	= p_{t_2}/p_{sl}
θ	= T_{t_2}/T_{sl}
σ	standard deviation , percent

Subscripts:

c	altered value
eff	effective
fac	facility
geom	geometric
j	jet (nozzle throat)
sl	sea level
t	total

Superscript:

'	functionally correlated value
---	-------------------------------

Facility and engine stations (figs. 1 and 3):

PL	inlet plenum
0	simulated free stream
1	inlet ducting
2	engine inlet

- 2.5 fan exit
- 4.5 fan turbine inlet
- 6 fan turbine exit
- 6.5 augmentor liner at flameholder
- 6.7 augmentor liner
- 6.9 augmentor liner in front of nozzle throat
- 7 nozzle throat
- 8 nozzle exit

ENGINE DESCRIPTION

The F100-PW-100 engine (fig. 1) is a low bypass, twin spool, augmented turbofan. The engine has 13 compression stages, composed of a three-stage fan (which is driven by a low pressure two-stage turbine) and a 10-stage compressor (which is driven by a high pressure two-stage turbine). The engines have a high compression ratio and achieve improved performance and distortion attenuation

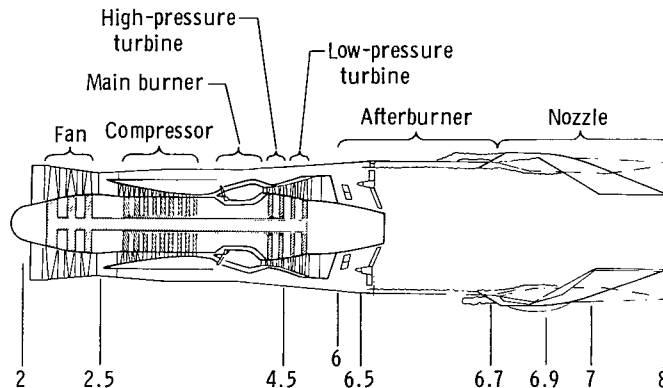

Figure 1. Prototype F100-PW-100 engine.

through the use of variable fan and compressor geometry. Continuously variable thrust augmentation is provided by a mixed-flow afterburner, which exhausts through a variable-area convergent-divergent nozzle.

The engines tested are designated as prototype series 2 7/8. The engines incorporate F100 series 2 cores (compressor, combustor, and high pressure turbine), but include the series 3 improved stability fan with recessed splitter.

The divergent nozzle is scheduled, unlike the nozzle on the series 3 engines, which is free floating. In addition, the engine control logic schedule is different from the series 2 and 3 engines.

The engines are primarily controlled by a unified hydromechanical fuel and nozzle control (UFC), with supervisory control performed by an engine electronic control (EEC). One of the functions of the EEC is to limit the minimum fan airflow to insure inlet stability. This is accomplished through the use of an airframe-supplied free-stream Mach number signal. Below Mach 0.90, the EEC allows engine operating power lever angle to go to idle. The minimum allowable value increases linearly with Mach number to intermediate power at a Mach number of 1.40. It remains constant at this level for higher Mach numbers. The free-stream Mach number was electrically supplied to the EEC by the facility and could be changed manually. This provided the ability to operate below intermediate for supersonic test conditions.

The convergent-divergent nozzle has a divergent section scheduled as a function of nozzle throat area, A_j . One of two area ratio (A_8 versus A_j) schedules is used, depending on the airframe-supplied free-stream Mach number: The low mode area ratio schedule is used for M_0 less than 1.10, and the high mode area ratio schedule is used for M_0 greater than 1.10. For afterburning operation, the facility's ability to alter the Mach number allowed operation on either of the two nozzle area ratio schedules. The performance of the two prototype engines as determined by the facility is reported in references 4 and 5. The serial numbers of the engines tested were P680059 (referred to hereafter as 059) and P680063 (hereafter 063).

TEST FACILITY AND EQUIPMENT

Test Facility

A photograph of the F100-PW-100 engine installed in the altitude facility is shown in figure 2. The facility had a calibrated load cell thrust bed for determining actual gross thrust. Further description of the facility can be found in reference 4.

Instrumentation

The facility and engine station designations and the corresponding instrumentation are shown in figures 1 and 3. All instrumentation was for steady-state purposes only, and all engine rakes and probes were flight-qualified hardware. All pressures except those at station 2 in the engine 059 tests were measured with scanivalves that were mounted external to the test chamber.

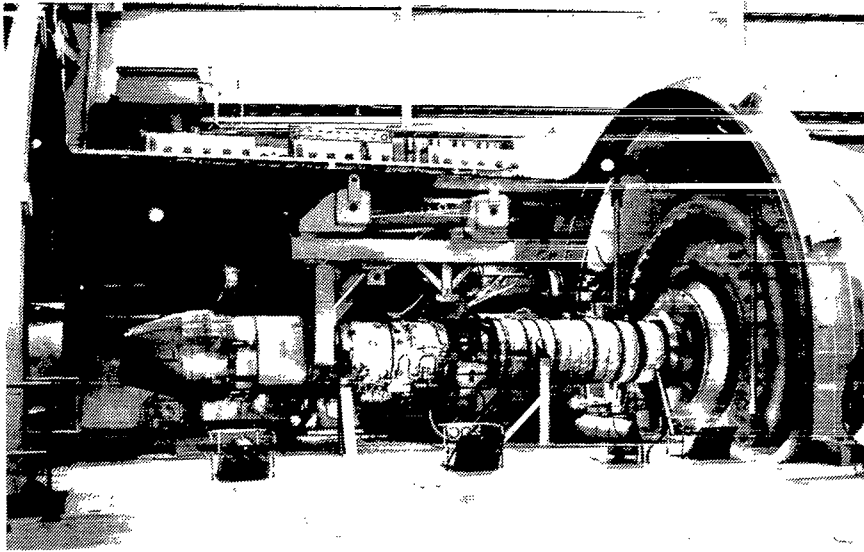

Figure 2. Prototype F100-PW-100 engine installed in facility.

The average of the plenum total temperature measurements was used as engine inlet temperature. Station 1 pressure instrumentation provided the facility values for engine face mass flow. Pressures at the labyrinth seal were used to monitor for seal leakage.

The station 2 rake used for the engine 059 tests had transducers that were mounted in the hub. The hub was temperature controlled; however, shifts in temperature were still observed. A special test was performed to determine the change in average total pressure with change in hub temperature, and the average value was corrected accordingly. The correction was consistent with average transducer specifications; the effect on the uncertainty of average total pressure was believed negligible.

At station 2.5, six total pressure measurements and three total temperature measurements were made. Station 4.5 instrumentation provided fan turbine inlet temperature.

Station 6 instrumentation consisted of a six-rake array with 30 total pressure probes, 12 in the fan duct stream and 18 in the core stream. Station 6.5, 6.7, and 6.9 instrumentation consisted of six static pressure ports located at approximately equal intervals around the circumference of the afterburner liner. The ports at one circumferential location in the afterburner liner are shown in figure 4.

Nozzle area was determined by using measurements from an engine-mounted linear potentiometer that was connected to the nozzle components downstream of the actuating cables. The potentiometer was air cooled to minimize calibration shifts due to temperature.

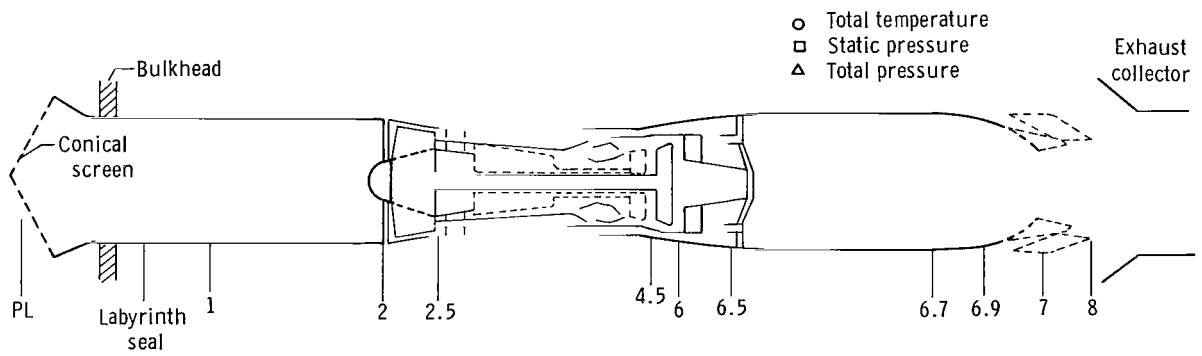

(a) Station locations.

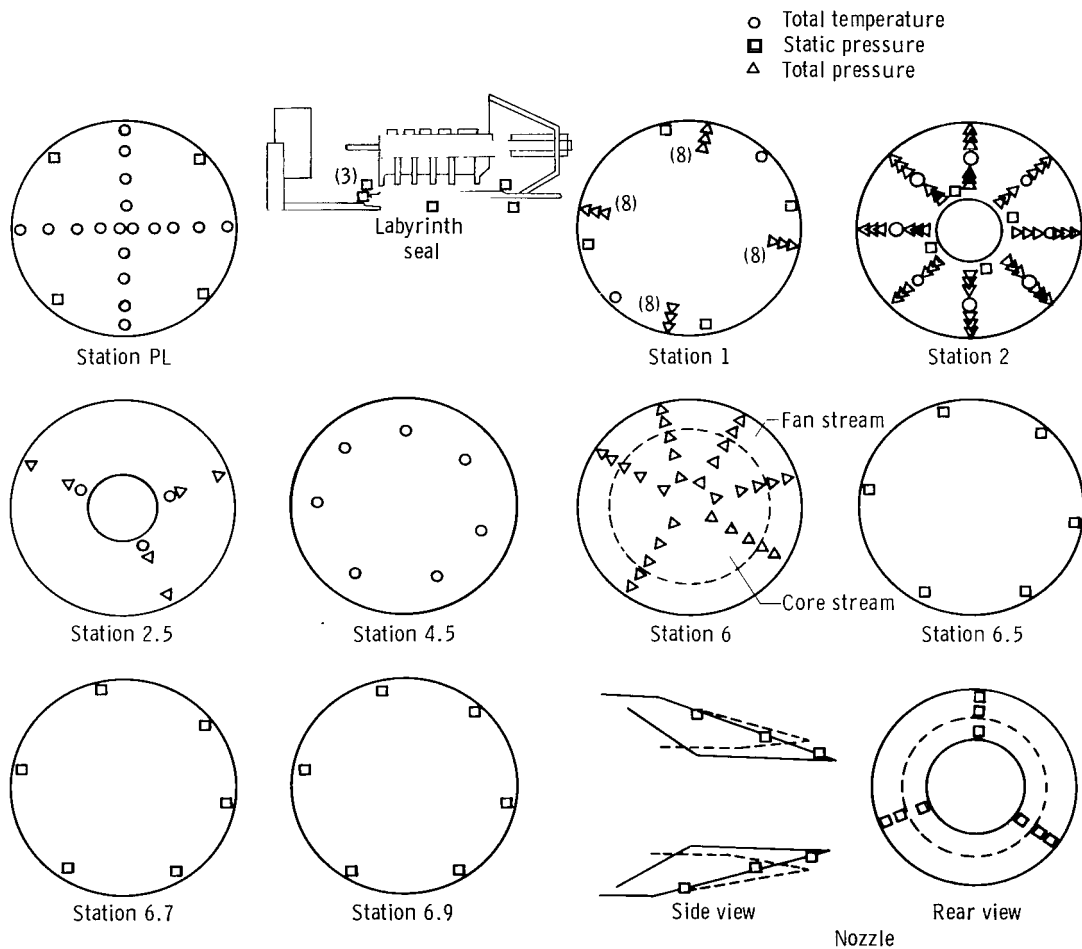

(b) Individual stations.

Figure 3. Engine instrumentation.

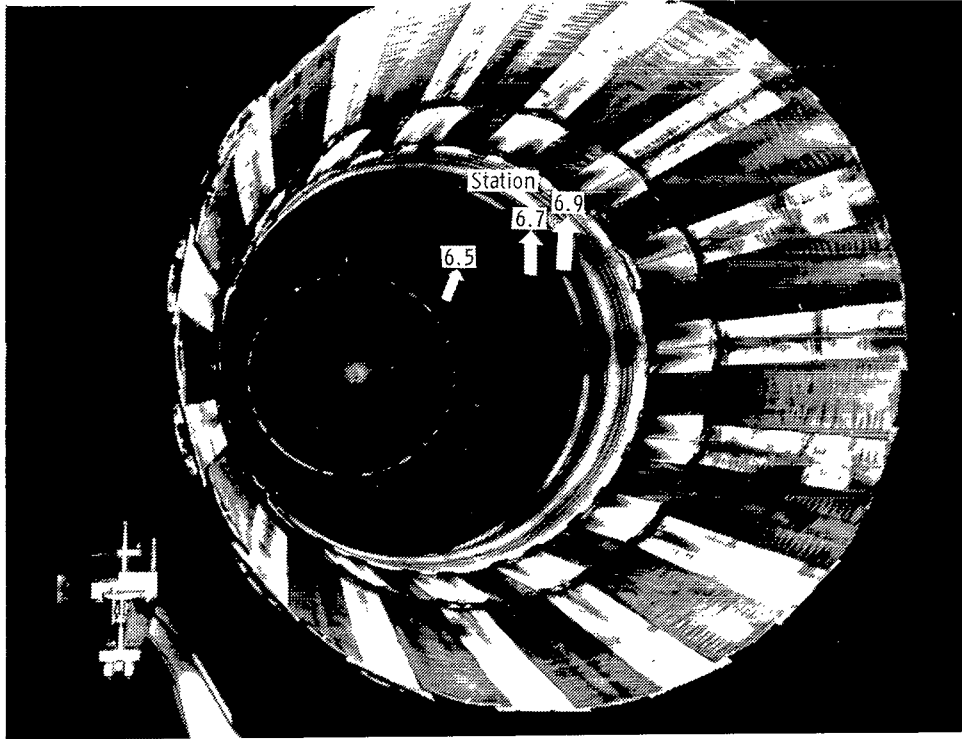

Figure 4. Afterburner static pressures.

Ambient pressure outside the exhaust nozzle was determined from static pressures measured on the exterior of the nozzle. The pressures at all nine facility and engine stations were in good agreement for all test conditions.

Table 1 lists the measurements pertinent to each model and the corresponding uncertainties. Facility instrumentation uncertainties are discussed in references 2, 4, and 5.

TABLE 1.—PARAMETER UNCERTAINTIES

Parameter	Uncertainty	Applicable to—	
		SGTM	GGM
p_0 , N/cm ²	±0.026	x	x
p_{t_2} , N/cm ²	±0.026	---	x
p_{t_6} , N/cm ²	±0.097	x	x
$p_{6.5}$, N/cm ²	±0.026	x	-
$p_{6.9}$, N/cm ²	±0.026	x	---
T_{t_2} , K	±1.78	---	x
FIGV, deg	±0.530	---	x
N_{fan} , percent	±0.1	---	x
A_j , percent—		---	x
Closed	±3.30		
Open	±1.86		
W_{fp} , kg/hr	±22.7	---	x
W_{ft} , kg/hr	±118.0	---	x

TEST CONDITIONS AND PROCEDURES

The test conditions for the engine calibrations are shown in table 2 and figure 5. After the selection of flight Mach numbers and altitudes, a representative

TABLE 2.—ENGINE TEST CONDITIONS

(a) Engine 059

M_0	Altitude, m	P_{t_2} , N/cm ²	T_{t_2} , K	P_0 , N/cm ²	RNI
0.80	4,020	9.27	^a 296	6.14	0.89
0.80	4,020	9.27	284	6.14	0.93
0.80	4,020	9.27	313	6.14	0.83
0.89	7,380	6.45	^a 278	3.90	0.66
1.20	12,100	4.54	^a 279	1.90	0.46
1.20	12,100	4.54	290	1.90	0.45
1.40	15,240	3.61	^a 301	1.16	0.34

^aStandard day.

(b) Engine 063

M_0	Altitude, m	P_{t_2} , N/cm ²	T_{t_2} , K	P_0 , N/cm ²	RNI
0.80	4,020	9.27	^a 296	6.14	0.89
0.89	7,380	6.45	^a 278	3.90	0.66
0.89	7,380	6.45	295	3.90	0.62
1.40	15,240	3.61	^a 301	1.16	0.34
0.90	13,720	2.48	^a 252	1.48	0.29
1.60	9,140	12.00	^a 339	3.01	0.96
2.00	15,240	8.56	^a 390	1.16	0.58

^aStandard day.

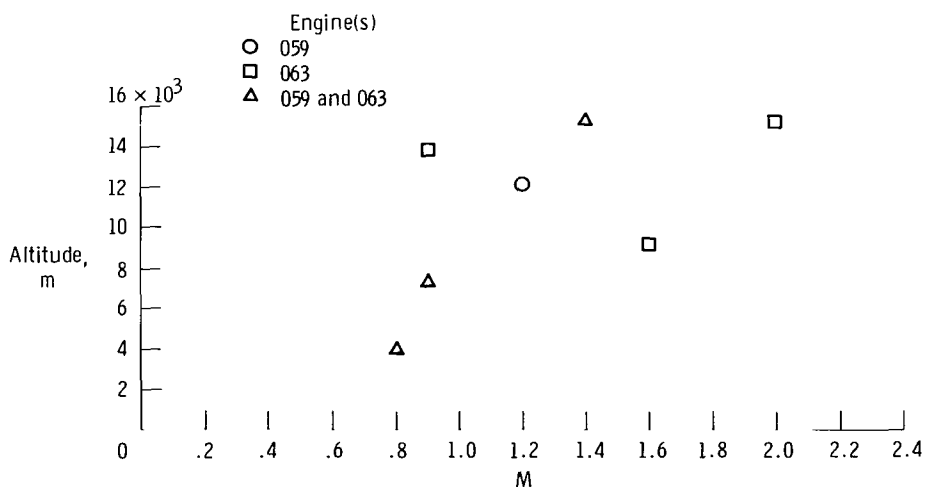

Figure 5. Test conditions.

inlet recovery value was chosen for each engine calibration test condition based on the expected flight values for that condition. The recovery value was assumed to be constant for each Mach number/altitude condition, although in practice the value varies with engine airflow.

Data were acquired at power lever angles from idle to maximum afterburning at all except two test conditions. The exceptions were the standard day tests for engine 063 at Mach 0.80 and an altitude of 4020 meters and Mach 0.89 and an altitude of 7380 meters. These two conditions were not tested with afterburner.

Engine 059 was trimmed at sea level before being installed in the altitude facility. Engine 063 was trimmed after being installed in the altitude facility. All the data presented here were gathered without altering the trim settings.

The general test procedure was to establish the facility on a given Mach number/altitude/RNI condition with the engine at an appropriate operating condition. Data were acquired only after first stabilizing at intermediate power. After stabilizing at intermediate power, data were acquired after a change of power lever angle as soon as the engine and facility were stable (after 1 minute minimum). Multiple data points were acquired at most engine operating conditions.

As mentioned above, free-stream Mach number was supplied to the EEC by the facility and could be changed artificially to cause the engine to operate on either of the two nozzle area ratio schedules or to permit it to operate below intermediate power at supersonic flow conditions. Engine operation at below intermediate power was achieved for Mach numbers greater than 0.90 by manually adjusting the Mach number signal to the EEC to a Mach number of 0.80. Besides eliminating the EEC-scheduled airflow bottoming limits, this procedure kept the divergent nozzle in the low area ratio schedule. For most afterburning tests at Mach numbers of 1.20 or greater, data were acquired with both area ratio schedules by changing the Mach number signal to the EEC, providing additional variations in nozzle performance.

ENGINE THRUST MODELS

Gas Generator Model

The manufacturer's engine gas generator model (ref. 6 and fig. 6(a)) is a gas generator analysis model which relies primarily on total pressure measurement and nozzle area for the determination of gross thrust. The model uses a combination of theoretical values, component test data, and full-scale engine data to generate the relationships necessary for the analysis.

First, corrected fan airflow is computed as a function of engine pressure ratio and corrected fan speed. The result is then corrected for inlet guide vane angle and Reynolds number. Station 6 total temperature, T_{t6} , is computed as a function

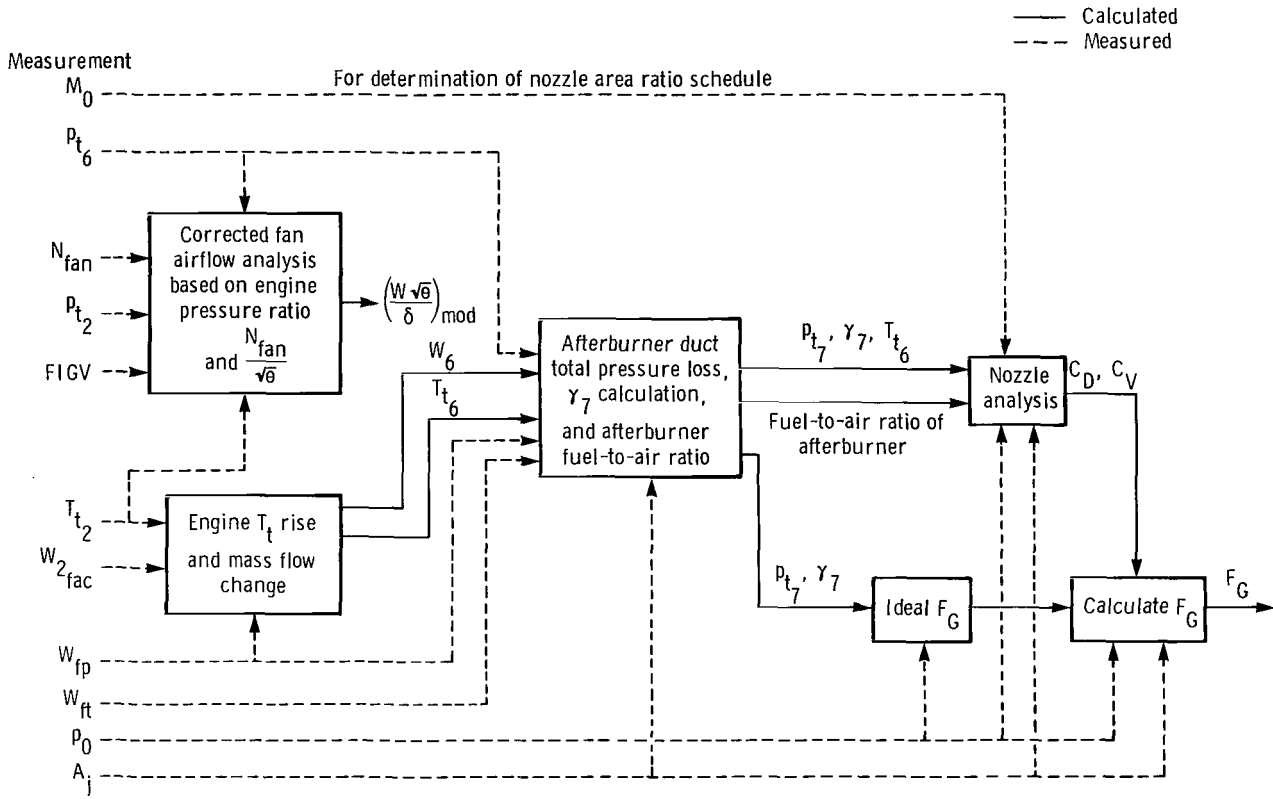

(a) Gas generator model.

Figure 6. Engine thrust models.

of engine core fuel-to-air ratio and inlet temperature. An analysis of the afterburner flow characteristics provides nozzle inlet total pressure, p_{t7} , and the ratio of specific heats, γ_7 . These two parameters are combined with free-stream ambient pressure to determine an ideal gross thrust. Nozzle discharge and velocity coefficients are determined from p_{t7} , A_j , nozzle area ratio, and γ_7 . The fuel-to-air ratio of the afterburner and T_{t6} are used to determine nozzle thermal expansion. The ideal thrust is combined with the nozzle coefficients to compute the actual gross thrust. The model was operated using the facility's value of engine airflow instead of the value calculated for the determination of gross thrust. This prevented uncertainties in the model's airflow calculation from affecting the gross thrust calibration.

Reference 1 discusses the application of a gas generator method of this type on a similar engine and indicates the effect of measurement uncertainties on the thrust computation.

Simplified Gross Thrust Model

The simplified gross thrust model, as developed in reference 3, is based on a one-dimensional analysis of the flow in the afterburner and nozzle. Calibration factors are required to account for three-dimensional effects, the effects of friction and mass transfer, and the effects of the simplifying assumptions used in the theory. The model is shown schematically in figure 6(b). (This technique provides only gross thrust. The determination of net thrust requires engine airflow, which must be computed by a different procedure.)

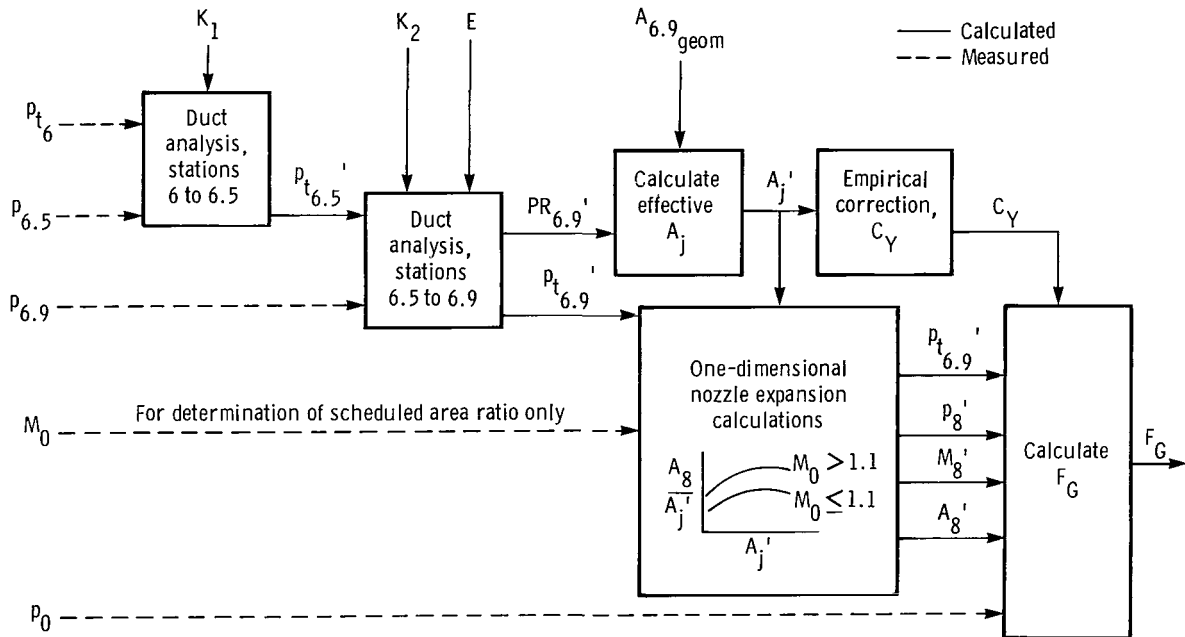

(b) Simplified gross thrust model. Choked flow case, $\gamma = 1.3$.

Figure 6. Concluded.

Four coefficients are used in the technique: K_1 , K_2 , E , and C_Y . Both K_1 and K_2 are constant, whereas E and C_Y vary with engine operating condition as follows:

$$E = f(p_{t_6}, p_{6.5}, p_0)$$

$$C_Y = f(A_j)$$

The coefficients are determined by a manually controlled iteration that seeks to minimize thrust error.

The necessary measurements are turbine discharge total pressure (p_{t_6}), flameholder static pressure ($p_{6.5}$), nozzle inlet static pressure ($p_{6.9}$), and free-stream static pressure (p_0). As stated previously, the nozzle area ratio is scheduled as a function of nozzle throat area (A_j) and free-stream Mach number (M_0), so an M_0 input must also be made. The technique also requires the nozzle geometric area at station 6.9 ($A_{6.9_{geom}}$).

The theoretical basis of the technique is described in reference 3. The model analyzes the afterburner duct flow as one-dimensional continuous flow, using influence coefficients; influence coefficients are discussed extensively in Chapter 8 of reference 7. For clarity, values that are based on a one-dimensional analysis that was empirically corrected are marked with a prime ('). These values can be considered to be functionally correlatable in the sense that they provide a repeatable value of gross thrust. This is not to imply, however, that the values necessarily differ greatly from the true value.

The calculation of gross thrust with the simplified gross thrust model relies on the calculation of nozzle throat total pressure (p_{t_7}') and effective area ($A_{j_{eff}}'$).

The first step in arriving at these values is an analysis of the flow in the duct between the fan turbine exit (station 6) and the flameholder entrance total pressure ($p_{t_{6.5}}'$).

The analysis assumes constant values of molecular weight, specific heat ($\gamma = 1.3$), total temperature, and mass flow. Mach number is represented as a function of p_{t_6} and $p_{6.5}$, and derivatives are approximated as the difference between the values at the two stations. With these assumptions,

$$p_{t_{6.5}}' = f(p_{t_6}, p_{6.5}, \gamma, K_1)$$

The analysis of the duct from station 6.5 to station 6.9 allows specific heat and molecular weight to vary. If the influence coefficient relationships for static pressure and Mach number are combined, and the derivatives are approximated as the difference between the values at the two stations,

$$x_{6.9} = f(p_{6.5}, p_{6.9}, K_2, E, x_{6.5})$$

where x is defined as (γM^2) and

$$K_2 = f(\text{Percent area change, percent momentum change})$$

The coefficient E is used to correct for all the assumptions involved in arriving at station 6.9 flow conditions, and also to absorb the effects of the assumption of one-dimensional, isentropic flow analysis in the convergent-divergent nozzle. The coefficient E acts to modify the measured value of $p_{6.9}$ to form a new value, $p_{c6.9}$. In other words,

$$p_{c6.9} = f(p_{6.9}, E)$$

or

$$x_{6.9} = f(p_{6.5}, p_{c6.9}, K_2, x_{6.5})$$

The value $p_{t6.9}'$ is calculated from the following Mach number/pressure relationship:

$$p_{t6.9}' = p_{c6.9} \left[1 + \frac{\gamma - 1}{2\gamma} (x_{6.9})^2 \right]^{\frac{\gamma}{\gamma - 1}}$$

The effective nozzle throat area can be computed for a choked nozzle as follows:

$$A_{j\text{eff}}' = f(A_{6.9\text{geom}}, p_{t6.9}', p_{c6.9}, \gamma)$$

This value of $A_{j\text{eff}}'$ is then used as if it were the measured geometric area A_j , and it is used in conjunction with free-stream Mach number to determine nozzle exit area, A_8' , from the area ratio schedule. If it is assumed that flow in a choked nozzle is isentropic, the nozzle exit Mach number can be determined as follows:

$$M_8' = f(A_8', A_{j\text{eff}}')$$

If it is assumed that the total pressure in the nozzle, p_{t8}' , is equal to both p_{t7}' and $p_{t6.9}'$, nozzle exit pressure, p_8' , can be expressed as follows:

$$p_8' = \frac{p_{t_8}'}{\left[1 + \frac{\gamma - 1}{2} (M_8')^2\right]^{\frac{\gamma}{\gamma - 1}}}$$

Then

$$F_G' = A_8' \gamma p_8' (M_8')^2 + A_8' (p_8' - p_0)$$

For an unchoked nozzle, subsonic flow expansion to ambient pressure is assumed, and the thrust equations can be expressed

$$F_G' = f(A_{6.9 \text{ geom}}, p_{t_{6.9}}', p_{c_{6.9}}, p_0, \gamma)$$

The values of K_1 , K_2 , and E are determined by using nonafterburning data. When the calculation is made for afterburning data, an empirical correction, C_Y , is necessary, such that

$$F_G = F_G' / C_Y$$

The value of C_Y is determined as a function of $A_{j_{\text{eff}}}'$, where the relationship is determined from a second-order curve fit of the error between F_G' and the facility-determined gross thrust. For nonafterburning data, the value of C_Y is approximately equal to one.

GROSS THRUST UNCERTAINTIES

This report uses the term uncertainty as the range of possible values of a parameter in the given test environment. For measurements, it is based on estimations of instrumentation errors (bias and random). For computations, it is computed as the root-sum-square (rss) of the responses of the computation to each measurement uncertainty.

Accuracy is defined as the deviation of values in relation to a defined reference (such as computed thrust versus facility load cell measured thrust).

The numbers for accuracy and uncertainty are valid only for the given test environment, but their relationship can be used to infer the accuracy of a computed parameter in an alternative test environment.

The gross thrust uncertainties are based on instrumentation uncertainty only. The values were generated by root sum squaring the errors in gross thrust that were due to the assumed uncertainty in each measurement.

Facility Gross Thrust Measurement Uncertainty

Figure 7(a) provides estimates of the uncertainty in the facility measurement of gross thrust. The determination of these values is described in reference 4. The uncertainties for the test conditions generalize into a single curve when plotted against measured gross thrust. The uncertainty in the facility gross thrust measurement ranges from 3.7 percent to less than 0.5 percent.

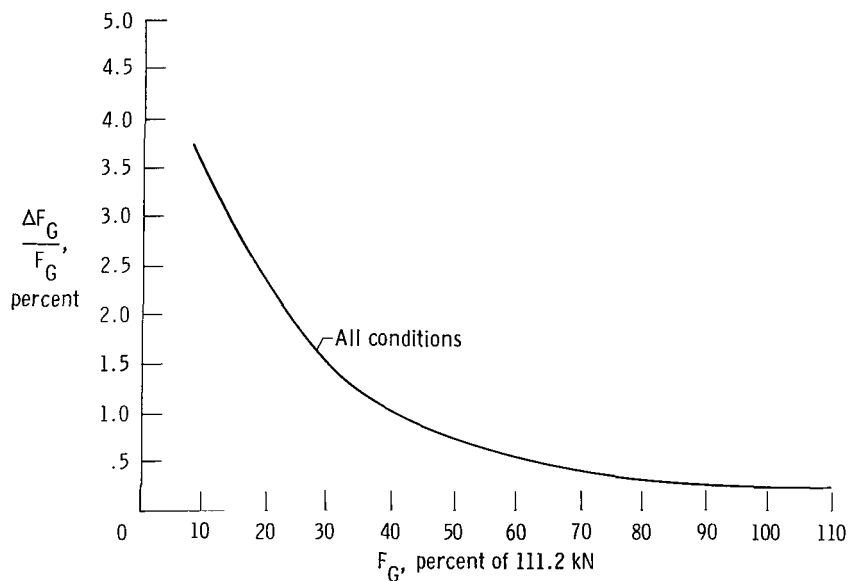

(a) Uncertainty in facility measurement.

Figure 7. Uncertainties in facility measurement and SGTM calculation of gross thrust.

Simplified Gross Thrust Model Calculation Uncertainty

Figure 7(b) shows estimates of the SGTM uncertainty in F_G due to instrumentation measurement uncertainties (table 1). Test conditions ranging from idle to maximum afterburning power at various standard day Mach number/altitude conditions were used. The uncertainty generalizes (± 0.15 percent) into a single line when plotted against the pressure difference across the afterburner duct, $p_{t_6} - p_{6.9}$.

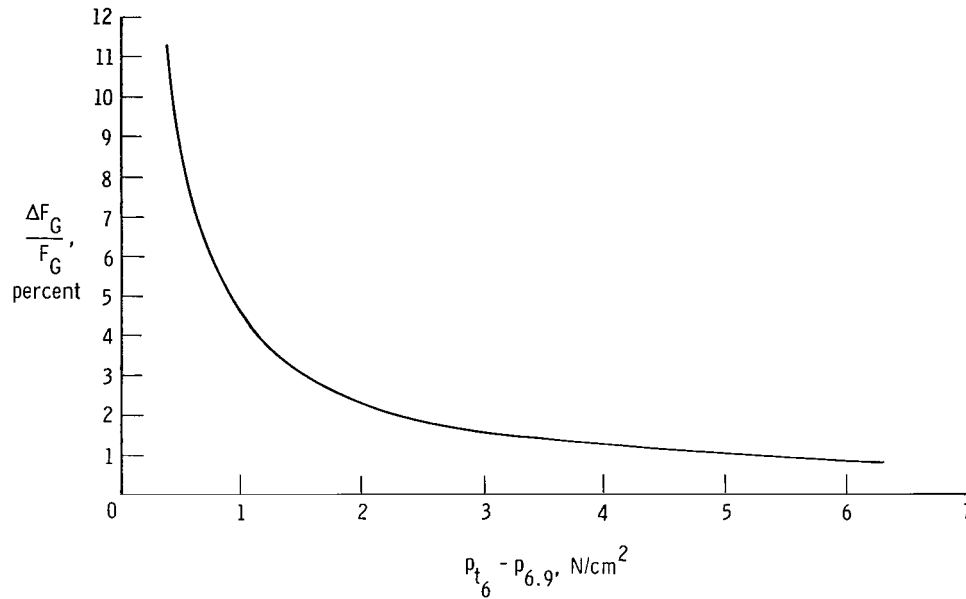

(b) Uncertainty in SGTM calculation.

Figure 7. Concluded.

The technique is most dependent on two measurements, p_{t_6} and $p_{6.9}$. As the pressure difference decreases, the uncertainty in the pressure measurements causes an exponential increase in the percentage of gross thrust calculation uncertainty.

Figure 8 shows gross thrust at various standard day Mach number/altitude/RNI conditions as a function of afterburner pressure difference. Taken in conjunction with figure 7(b), these curves give an indication of the uncertainty in F_G in kilonewtons for various flight conditions.

Gas Generator Model Uncertainty

Reference 2 gives a comprehensive discussion of the calibrated gas generator model accuracy. The twice standard deviation of the calibrated model for both engines is approximately 2.40 percent of value, based on comparisons to the facility measurement.

Reference 1 discusses the effects on gross thrust uncertainty of individual measurement uncertainties on a similar engine.

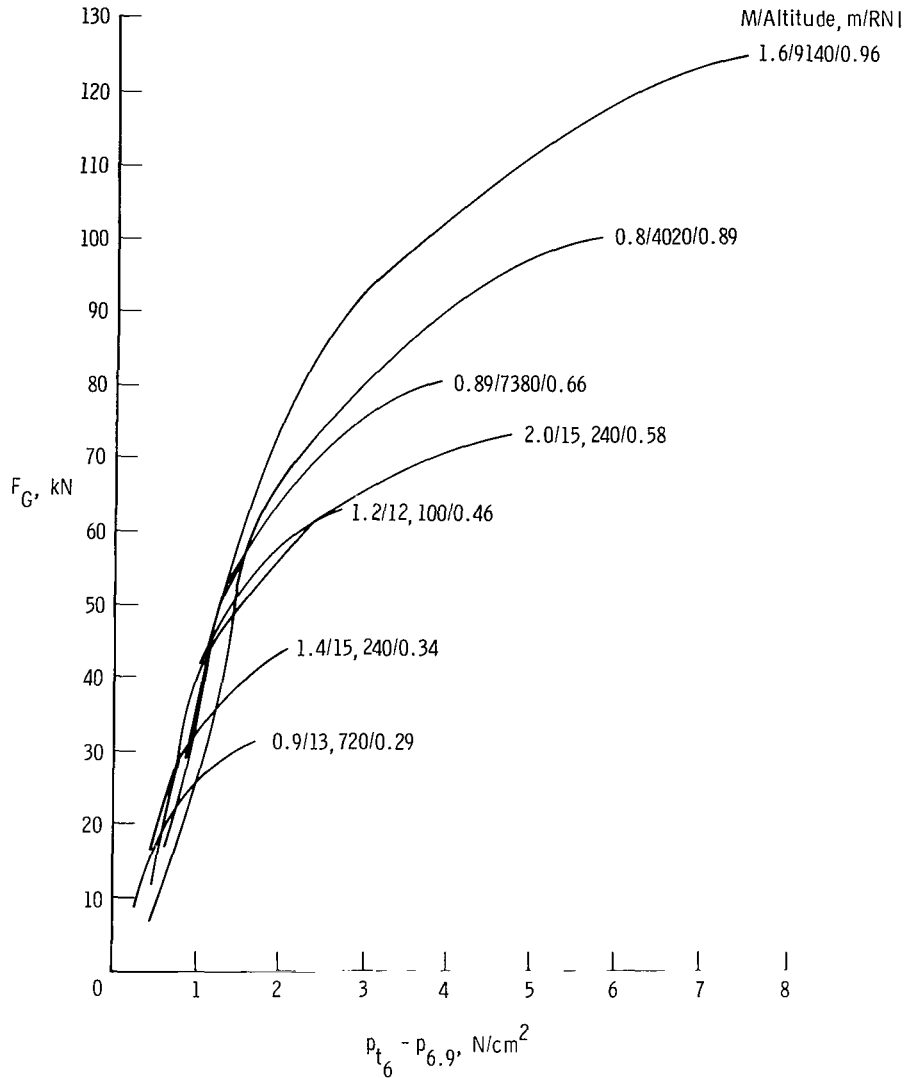

Figure 8. Correlation of afterburner pressure difference with gross thrust for standard day conditions.

RESULTS AND DISCUSSION

Simplified Gross Thrust Model Coefficients

As stated above, the coefficients K_1 , K_2 , E , and C_Y were determined from a manually controlled iteration that sought to minimize thrust error. It was found that gross thrust error could be reasonably minimized at any one flight condition

for different values of the coefficients. Therefore, the selection of final values for K_1 , K_2 , E , and C_Y was based on data acquired at all flight conditions tested.

Comparison of Simplified Gross Thrust Model With Facility

Figure 9 compares the simplified gross thrust model data with the facility-measured thrust data. The estimated uncertainty in the SGTM due to instrumentation uncertainties is also plotted for comparison. In general, the error increases as the pressure difference $p_{t_6} - p_{6.9}$ decreases, as predicted by the uncertainty analysis above.

The data also indicate that for engine 059, the SGTM has a small overall bias, tending to underpredict thrust by 0.5 percent to 1 percent for pressure differences less than 3.0 N/cm^2 . The variation remains within the estimated uncertainty due to instrumentation, however.

The Mach 1.4, 15,240 meter data are generally well behaved. In reference 2, this condition was suspect for nonafterburning operation. The simplified gross thrust model tends to support the facility values.

Engine 063 (fig. 9(b)) exhibits the same general characteristics in terms of the percentage of error, which increases with decreasing afterburning duct pressure difference. For values of $p_{t_6} - p_{6.9}$ less than 1.40 N/cm^2 , the simplified gross thrust model tends to underpredict thrust for the standard day, nonafterburning test conditions at Mach 0.90 and 13,720 meters and at Mach 2.00 and 15,240 meters. As pointed out in reference 2, the Mach 0.90, 13,720 meter data were subject to considerable uncertainty due to facility uncertainty. The underprediction for the Mach 2.00, 15,240 meter data is generally for nonafterburning engine operation, which is not a normal operating condition.

The simplified gross thrust model tends to overpredict thrust by 1 percent to 2 percent of value for pressure differences greater than 3.00 N/cm^2 at standard day flight conditions of Mach 1.60 and 9140 meters and Mach 2.00 and 15,240 meters. Since these conditions were not tested with engine 059, it is not known whether this effect was due to engine differences or whether it characterized the simplified gross thrust model at these test conditions.

Data were acquired at the Mach 2.00 and 15,240 meter standard day conditions at a pressure difference of 4.60 N/cm^2 for both divergent nozzle area ratio schedules at the same nozzle pressure ratio. The low area ratio data overpredict thrust by less than 1 percent, whereas the higher area ratio data overpredict thrust by slightly more than 2 percent. This 1 percent difference is also indicated by a comparison of the Mach 0.89, 7380 meter, 295 K data with Mach 1.60, 9140 meter data. (The Mach 0.89 data were acquired with a low area ratio while

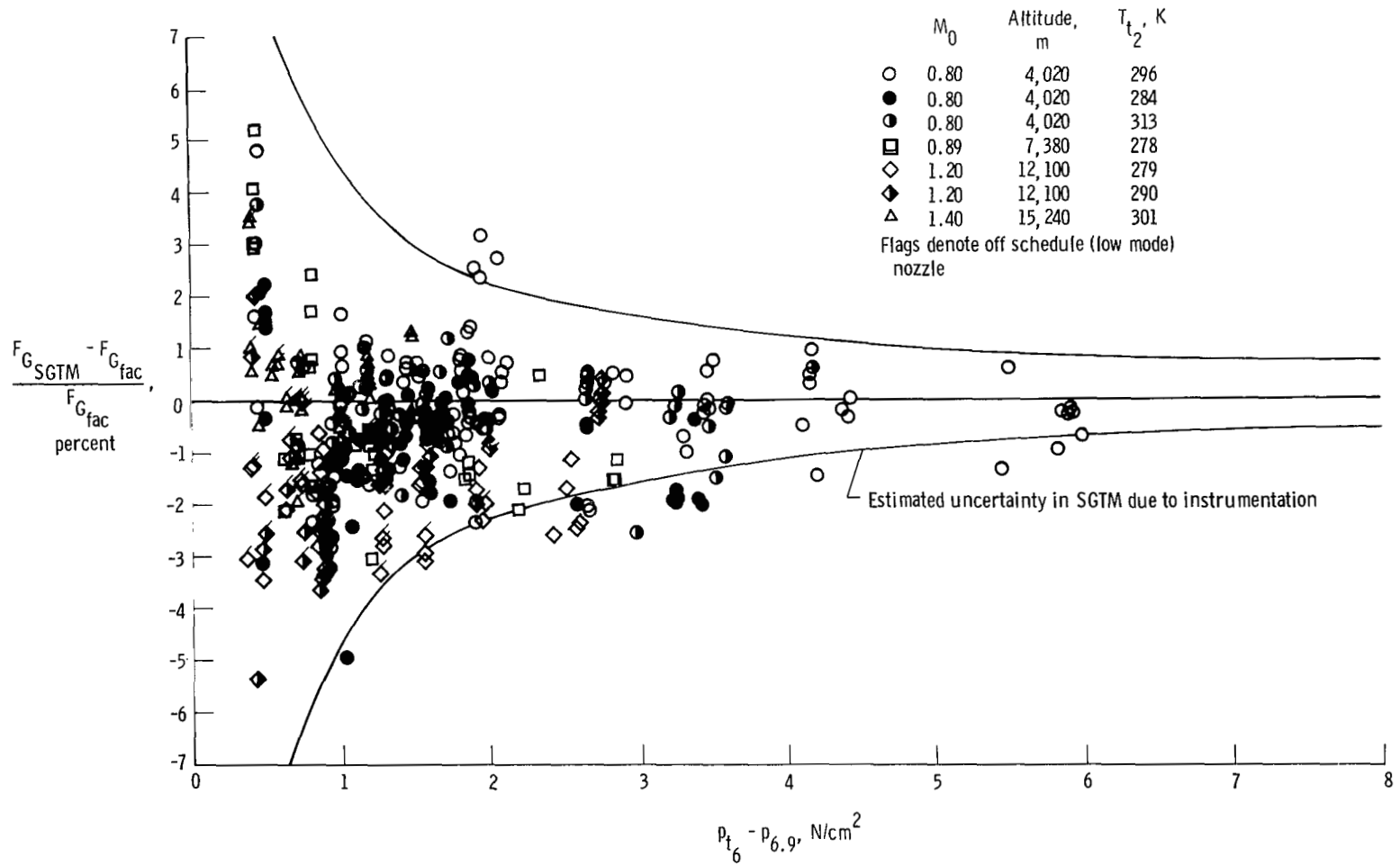

(a) Engine 059.

Figure 9. Comparison of SGTM-calculated with facility-measured thrust.

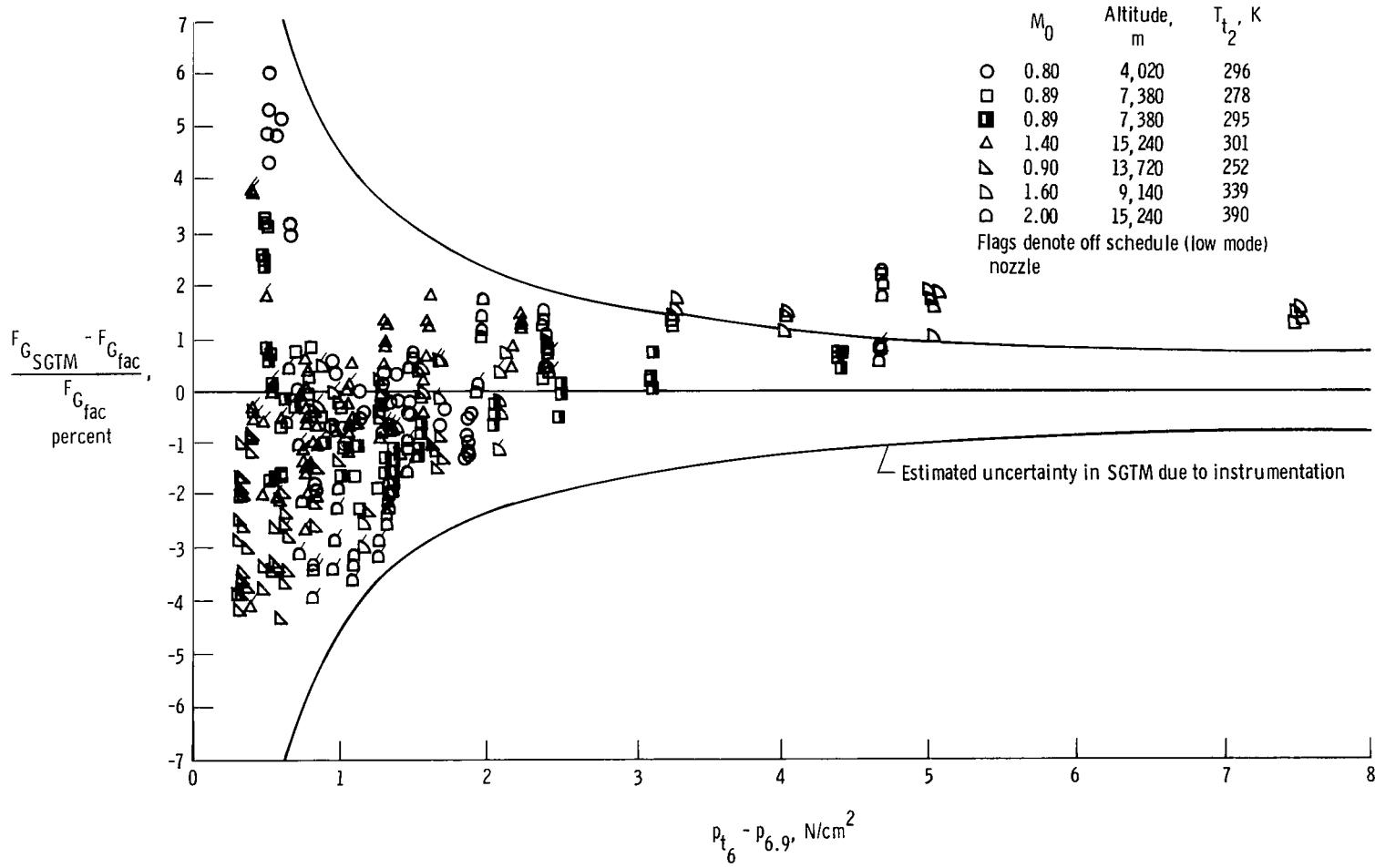

(b) Engine 063.

Figure 9. Concluded.

the Mach 1.60 data were acquired with a high area ratio.) As explained in the ENGINE DESCRIPTION section of this report, area ratio schedule is controlled by free-stream Mach number, which was overridden in the facility to acquire all nonafterburning supersonic data and some afterburning supersonic data. All data with a false facility EEC Mach number are flagged. The overprediction is felt to be attributable to the SGTM technique.

Table 3 lists 2σ values of thrust accuracy for engines 059 and 063. The 2σ values are 2.89 percent for engine 059 and 2.80 percent for engine 063 if the

TABLE 3.—SGTM ACCURACY

(a) Engine 059

Data used	Comparison	Number of data	2σ , percent
All	SGTM with facility	396	2.89
	SGTM with GGM	396	2.91
Exclude low mode nozzle area ratio data at $M_0 > 1.1$	SGTM with facility	325	2.50
	SGTM with GGM	325	2.47

(b) Engine 063

Data used*	Comparison	Number of data	2σ , percent
All	SGTM with facility	267	2.80
	SGTM with GGM	267	2.86
Exclude low mode nozzle area ratio data at $M_0 > 1.1$	SGTM with facility	168	2.42
	SGTM with GGM	168	2.10

*Excluding Mach 0.90, 13,720 meter standard day data.

Mach 0.90 and 13,720 meter standard day data are excluded. If the low mode nozzle area ratio schedule data at supersonic free-stream Mach numbers (and therefore supersonic operation at below intermediate power) are excluded, the 2σ values improve by about 0.40 percent, to 2.50 percent for engine 059 and to 2.42 percent for engine 063.

Comparison of Simplified Gross Thrust Model With Gas Generator Model

A comparison of the simplified gross thrust model data with reference 2 calibrated gas generator model data (fig. 10) indicates essentially the same characteristics as the comparison of the SGTM data with the facility data. This supports using the gas generator model to evaluate flight test applications of the simplified gross thrust model. The similarity of the comparison also indicates that neither model has large biases for the indicated test conditions. Thus, flight evaluation of the SGTM and GGM techniques depends mainly on the accuracy of the instrumentation.

Minor exceptions to the uniformity of agreement are the Mach 1.40, 15,240 meter, standard day data for engine 059, where the SGTM agrees with the facility better than with the GGM for nonafterburning operation, and the Mach 0.90, 13,720 meter, standard day data for engine 063, where the two models agree with each other but disagree with the facility.

The Mach 2.00, 15,240 meter standard day data for engine 063 tend to support the nozzle area ratio bias indicated by the SGTM-to-facility comparison, but the Mach 1.60, 9140 meter, standard day data for engine 063 do not. The differences are believed to be due to the assumptions made in calibrating the GGM (ref. 2).

Table 3 gives 2σ values for the model-to-model comparison of 2.91 percent for engine 059 and of 2.86 percent for engine 063, if the Mach 0.90, 13,720 meter standard day data are excluded. If the low mode nozzle area ratio schedule data at supersonic free-stream Mach numbers are also excluded, the 2σ values improve to 2.47 percent for engine 059 and 2.10 percent for engine 063. The gas generator model was shown in reference 2 to have a 2σ accuracy of approximately 2.40 percent. The SGTM has comparable accuracy for the range of conditions tested.

CONCLUSIONS

A simplified gross thrust model was evaluated in an altitude facility on a prototype F100-PW-100 afterburning turbofan engine. Comparisons were made with the facility values of gross thrust and with the calibrated engine manufacturer's gas generator model gross thrust values. The simplified gross thrust model demonstrated an accuracy of approximately 2.50 percent of value over the range of possible flight conditions, and an accuracy of 2.89 percent of value for all conditions tested. The comparisons of the simplified gross thrust model with the gas generator model indicated approximately the same accuracy. The accuracy was found to be dependent on the size of the pressure difference across the afterburner duct, $p_{t6} - p_{6.9}$, and therefore on the accuracy of the pressure measurement system. The accuracy of the method was generally similar to the estimated instrumentation uncertainty.

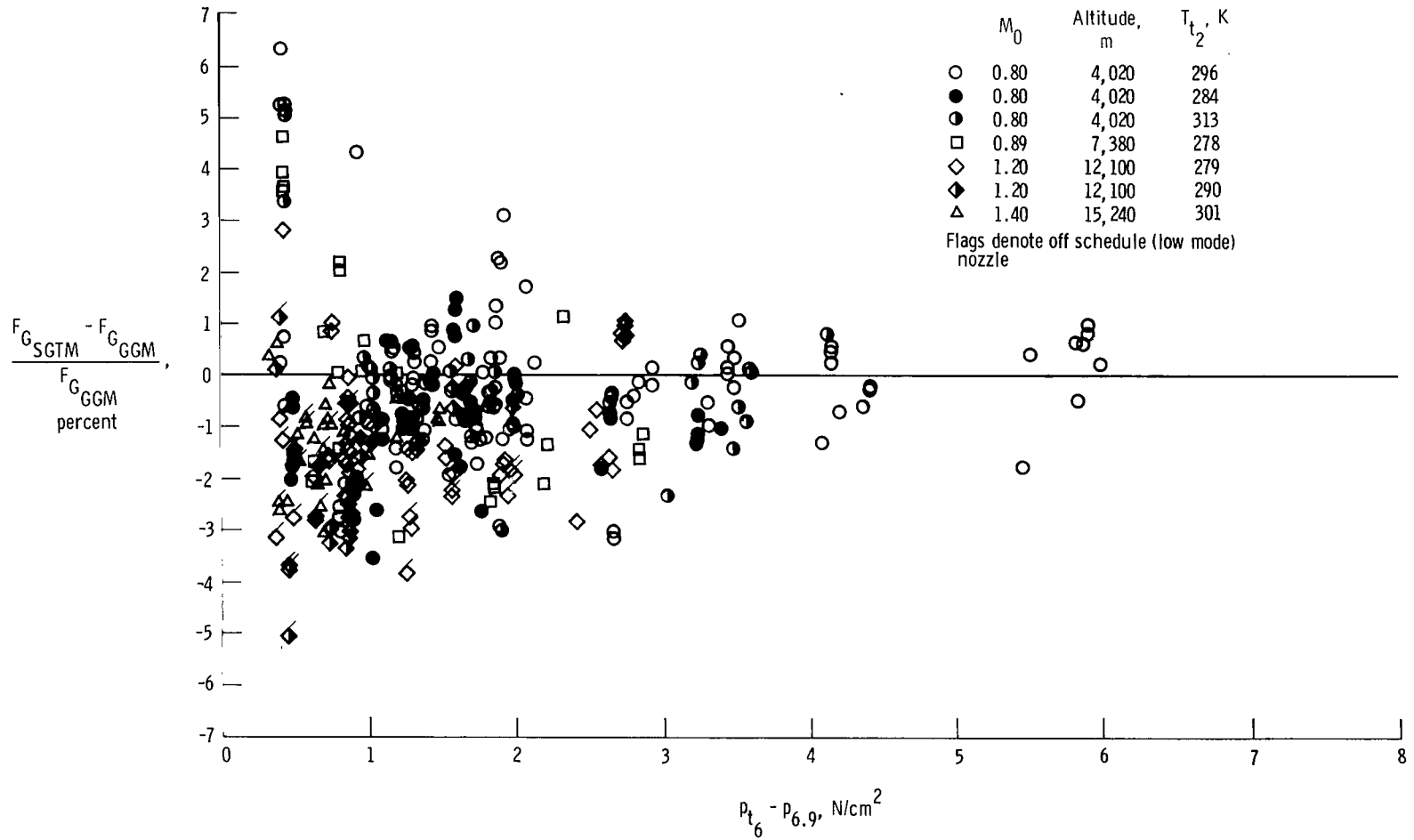

(a) Engine 059.

Figure 10. Comparison of thrust difference between SGTM and GGM.

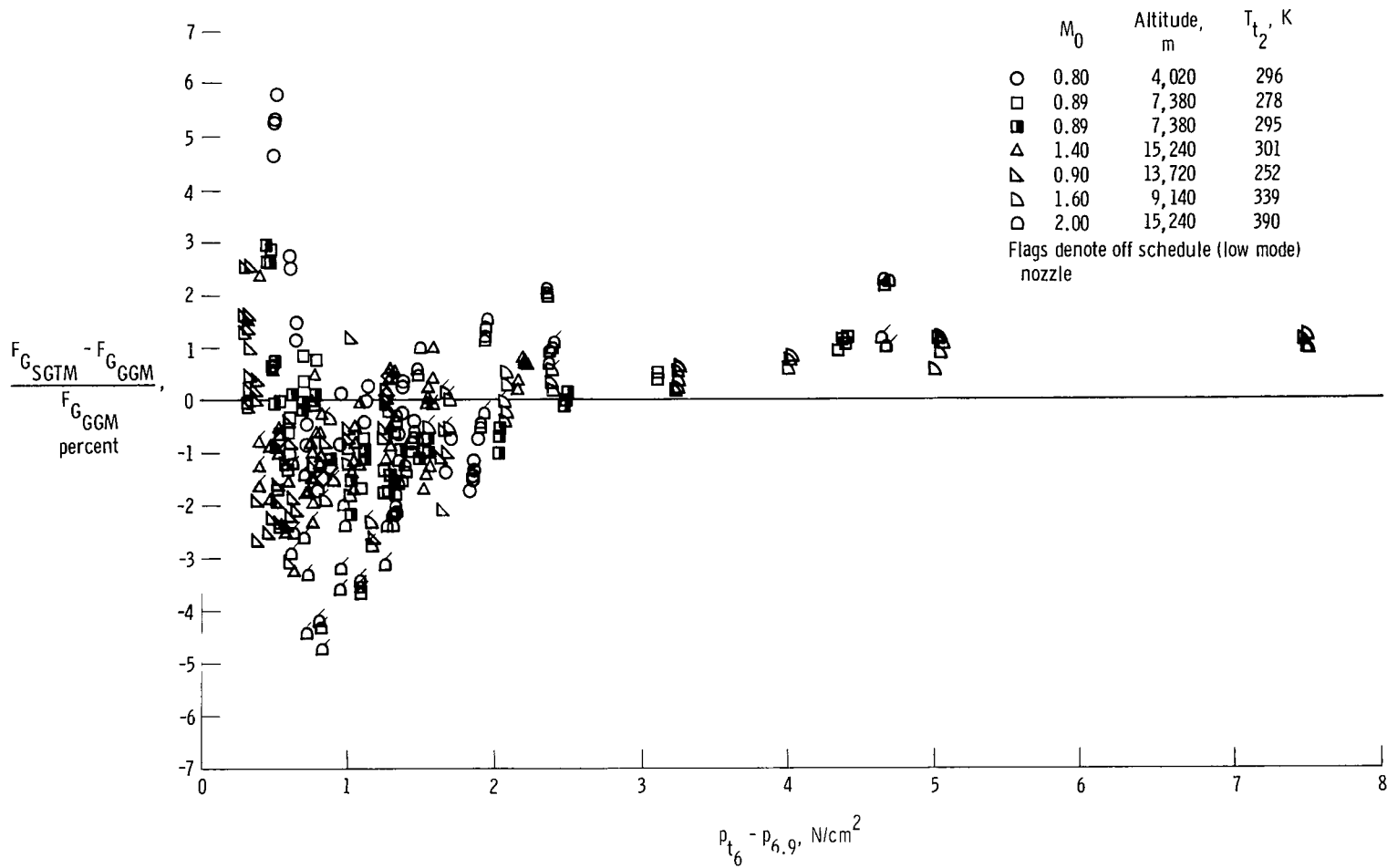

(b) Engine 063.

Figure 10. Concluded.

The calibrated gas generator model was shown to be suitable for evaluating flight test applications of the simplified gross thrust model.

*Dryden Flight Research Center
National Aeronautics and Space Administration
Edwards, California, November 16, 1978*

REFERENCES

1. Burcham, Frank W., Jr.: An Investigation of Two Variations of the Gas Generator Method To Calculate the Thrust of the Afterburning Turbofan Engines Installed in an F-111A Airplane. NASA TN D-6297, 1971.
2. Kurtenbach, Frank J.: Comparison of Calculated and Altitude-Facility-Measured Thrust and Airflow of Two Prototype F100 Turbofan Engines. NASA TP-1373, 1978.
3. McDonald, G. B.: Theory and Design of an Airborne Thrust Computing System. H036/119/FR/IV, Computing Devices (Ottawa), Aug. 1974.
4. Biesiadny, Thomas J.; Lee, Douglas; and Rodriguez, Jose R.: Airflow and Thrust Calibration of an F100 Engine, S/N P680059, at Selected Flight Conditions. NASA TP-1069, 1978.
5. Biesiadny, Thomas J.; Lee, Douglas; and Rodriguez, Jose R.: Altitude Calibration of an F100, S/N P680063, Turbofan Engine. NASA TP-1228, 1978.
6. F100 (3) In-Flight Thrust Calculation Deck. CCD 1088-2.0, Pratt & Whitney Aircraft, 1975.
7. Shapiro, Ascher H.: The Dynamics and Thermodynamics of Compressible Fluid Flow. Vol. 1, Ronald Press Co., c.1952.

1. Report No. NASA TP-1482	2. Government Accession No.	3. Recipient's Catalog No.
4. Title and Subtitle EVALUATION OF A SIMPLIFIED GROSS THRUST CALCULATION TECHNIQUE USING TWO PROTOTYPE F100 TURBOFAN ENGINES IN AN ALTITUDE FACILITY		5. Report Date June 1979
7. Author(s) Frank J. Kurtenbach		6. Performing Organization Code
9. Performing Organization Name and Address NASA Dryden Flight Research Center P. O. Box 273 Edwards, California 93523		8. Performing Organization Report No. H-1061
12. Sponsoring Agency Name and Address National Aeronautics and Space Administration Washington, D. C. 20546		10. Work Unit No. 505-11-24
15. Supplementary Notes		11. Contract or Grant No.
16. Abstract A simplified gross thrust calculation technique was evaluated in an altitude facility using two prototype F100-PW-100 engines. The technique relies on afterburner duct pressure measurements and empirical corrections to an ideal one-dimensional flow analysis to determine thrust. This report presents a comparison of the calculated and facility measured thrust values. It also compares the simplified model with the engine manufacturer's gas generator model. The evaluation was conducted over a range of Mach numbers from 0.80 to 2.00 and at altitudes from 4020 meters to 15,240 meters. The effects of variations in inlet total temperature from standard day conditions were explored. Engine conditions were varied from those normally scheduled for flight. The technique was found to be accurate to a twice standard deviation of 2.89 percent, with accuracy a strong function of afterburner duct pressure difference.		13. Type of Report and Period Covered Technical Paper
17. Key Words (Suggested by Author(s)) Gross thrust Engine performance		14. Sponsoring Agency Code
18. Distribution Statement Unclassified-Unlimited STAR category: 07		
19. Security Classif. (of this report) Unclassified	20. Security Classif. (of this page) Unclassified	21. No. of Pages 31
		22. Price* \$3.75

*For sale by the National Technical Information Service, Springfield, Virginia 22161

National Aeronautics and
Space Administration

Washington, D.C.
20546

Official Business

Penalty for Private Use, \$300

THIRD-CLASS BULK RATE

Postage and Fees Paid
National Aeronautics and
Space Administration
NASA-451



8 1 1U, A, 052579 S00903DS
DEPT OF THE AIR FORCE
AF WEAPONS LABORATORY
ATTN: TECHNICAL LIBRARY (SUL)
KIRTLAND AFB NM 87117

NASA

S

POSTMASTER: If Undeliverable (Section 158
Postal Manual) Do Not Return