

NASA Technical Paper 1489



LOAN COPY: RETURN
AFWL TECHNICAL LIBRARY
KIRTLAND AFB, NM

Auger Spectroscopy Analysis of Lubrication With Zinc Dialkyldithiophosphate of Several Metal Combinations in Sliding Contact

Donald H. Buckley

JULY 1979





NASA Technical Paper 1489

Auger Spectroscopy Analysis
of Lubrication With Zinc
Dialkyldithiophosphate of
Several Metal Combinations
in Sliding Contact

Donald H. Buckley
Lewis Research Center
Cleveland, Ohio



National Aeronautics
and Space Administration

**Scientific and Technical
Information Branch**

1979

SUMMARY

An investigation was conducted to determine the effectiveness and the mechanism of lubrication of various metal surfaces by the common antiwear additive zinc dialkyldithiophosphate (ZDP). Sliding friction experiments were conducted with aluminum and other riders sliding on various metal disks including iron, titanium, tungsten, rhodium, molybdenum, and copper with a thin film of ZDP applied to the disk surfaces. Experiments were conducted at loads of 100 to 1600 grams and at a sliding velocity of 30 centimeters per minute at 23⁰ C. An Auger emission spectroscopy analysis was used to in situ monitor changes in surface chemistry with sliding.

The results of this study indicate that the ability of ZDP to lubricate is strongly dependent on the chemistry of the metal being lubricated. Furthermore, the active element in ZDP contributing to lubrication is also a function of the metal chemistry. The zinc in the organometallic molecule was found to be susceptible to electron beam induced desorption while the other elements in the molecule were not; this indicated relative binding to the metal surface of the elements in the molecule.

INTRODUCTION

Zinc dialkyldithiophosphate (ZDP) is one of the most widely used antiwear additives in the formulation of engine oils. However, the exact mechanism of lubrication and antiwear protection afforded by this compound is not yet understood (ref. 1). It is generally believed to be related to the decomposition of the molecular structure of the additive (refs. 2 to 5) with the formation of a protective surface film from one of the decomposition products (ref. 6). Its lubrication mechanism is complicated by the interaction of ZDP with the other additives present in the oil (ref. 7).

There are a number of surface active elements present in the molecular structure aside from the organic portion of the molecule. These include zinc, sulfur, phosphorus, oxygen, and carbon. Conceivably any one or all of these active elements could react with the surface to form a protective surface film. It should be possible to identify changes in surface chemistry and the effect of the additive by examining a film of ZDP in a sliding friction experiment with an in situ Auger emission spectroscopy analysis.

The objective of the present investigation was to examine the effect of a thin film of ZDP on various metal surfaces during sliding friction experiments while monitoring the film elemental chemistry with a cylindrical mirror Auger spectroscopy analysis.

Experiments were conducted at various loads from 100 to 1600 grams at a sliding velocity of 30 centimeters per minute and at 23^o C with a hemispherical rider sliding on a rotating flat disk specimen. A cylindrical mirror Auger analyzer monitored the surface chemistry in the wear track.

MATERIALS

The aluminum, copper, and silver used in this investigation were 99.999 percent pure; the iron, tungsten, rhodium, and molybdenum were 99.99 percent pure; and the titanium was 99.95 percent pure with the principal impurity being the oxide.

The ZDP was a research grade obtained from Exxon Research Laboratories in Linden, New Jersey. The actual compound is zinc-O-O = di-h-pentyl phosphorodithioate. The structure is

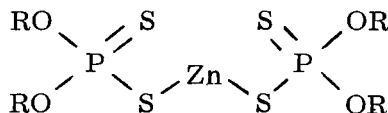

This structure is a general one where the length of R can vary. In the present case, R = C₅H₁₁.

EXPERIMENTAL APPARATUS AND PROCEDURE

The experiments were conducted in a vacuum chamber (fig. 1). The vacuum system was pumped by sorption pumps and an ion gage. Pressure in the vacuum system was read with an ion gage.

Specimens

The friction and wear specimens were disks 6.5 centimeters in diameter and 1.2 centimeters thick with a hemispherical rider having a 2.5-centimeter radius. The specimens are shown in the apparatus schematic of figure 1. The disk specimen was mounted on a drive shaft that was rotated by a magnetic drive assembly. The drive assembly provides rotation at various speeds - in this study, 30 centimeters per minute. For sputter cleaning the rider specimen was mounted in an insulated holder on one end of a stainless-steel shaft. Friction and wear experiments were conducted with the rider specimen loaded against the disk surface. As the disk was rotated, the rider scribed a circular wear trace on the flat surface of the disk. The loads used in this investigation were from 100 to 1600 grams and the temperature was 23^o C.

Measurements

The friction force between the disk and rider specimens was continuously recorded during the experiment. The beam containing the rider specimen was welded in a bellows assembly that was gimbal mounted to the vacuum system. The gimbal mounting permits deadweight loading of the rider against the disk surface (fig. 1). At right angles to the deadweight loading, the beam containing the rider can move in two directions in the horizontal plane. The tendency of the rider to move with the disk as it rotates was restrained by a cable attached to a temperature-compensated strain gage. These gages measured the frictional force between the disk and the rider specimens. The frictional force was recorded on a x, y-chart.

Specimen Preparation and Cleaning

The disk specimens were finish ground on metallurgical papers to a grit of 600. They were then diamond polished with a 3-micrometer diamond paste and finally a 1-micrometer aluminum oxide. The disks were rinsed with acetone and then with absolute ethyl alcohol.

Before the rider specimens were used, they were electropolished with phosphoric acid to remove metal and other contaminants that might have become embedded in the surface from finishing. They were then rinsed in water and finally rinsed in ethyl alcohol.

Auger Analysis

An elemental analysis of the disk specimen surface could be made before, during, and after the friction and wear experiments by using an Auger cylindrical-mirror analyzer with an integral electron gun. The point of rider to disk contact passed under the Auger beam at 180° from the contact zone. The Auger analyzer is a commercial unit, the essential elements of which are described in the literature.

The primary beam of electrons was directed at the disk surface by an electron gun in the Auger cylindrical-mirror analyzer. The beam was focused on the wear track scribed by the rider in sliding contact with the disk. The beam contact was 180° away from the rider on the disk surface. The beam spot diameter was 0.2 millimeter. The gun contains deflection plates that allow positioning the beam on the disk surface.

The secondary electrons came off the specimen surface, passed through the outer cylindrical can opening, passed through slits in an inner cylinder that serves as an energy analyzer, and finally were collected by the electron multiplier. The elements

were identified by analyzing the detected secondary-electron energies. The Auger electrons that appeared in the secondary-electron distribution chemically identified the surface elements to a depth of approximately four atomic layers.

Auger traces were plotted on an x, y-recorder. In this investigation, surfaces were examined before, during, and after sliding.

A sample scanning positioner was incorporated into the Auger spectrometer. With this positioner, the wear track could be magnified and visually displayed on a television monitor, and the beam of the electron gun could be positioned directly into the wear contact zone desired. Each data point acquired for Auger peak height ratios was based on three measurements in different regions of the wear track.

The experimental procedure used in this study may be summarized in the following steps: (1) preparing the specimen, (2) coating the disk surface with a film of ZDP, (3) installing the specimen in the vacuum system and evacuating the system, (4) cylindrical mirror Auger analysis (CMA) characterization of the surface, (5) sliding the specimen for 25 passes in vacuum while continuously measuring friction, (6) making CMA measurements within the wear track, and (7) sliding the specimen for an additional 25 passes and preexamining the surface with CMA.

RESULTS AND DISCUSSION

A thin film of ZDP was applied to an iron disk surface with a cotton swab. The surface had a resultant film of 0.30 milligram per square centimeter of disk surface area. This was done just prior to evacuating the vacuum system. Various riders, made of iron, aluminum, titanium, and silver, were slid against an iron surface coated in this manner. The friction coefficients measured at various loads in these experiments are presented in figure 2.

An examination of figure 2 indicates that, while differences in friction coefficients exist, all the data could be represented by a single curve. There appears to be a trend in friction with load. The friction coefficient is relatively insensitive at the various loads to the rider metal. An Auger emission spectroscopy analysis of the films in the wear tracks indicated that the surface chemistries were essentially the same. The Auger spectra contained phosphorus, sulfur, carbon, and oxygen with occasional appearances of zinc in essentially the same relative amounts.

All the Auger spectra indicated a very effective shielding of the iron disk surface by the ZDP because no iron peaks were detected in the Auger spectra. The friction and Auger results indicate that the thin film of ZDP was tenaciously bonded to the surface and was not displaced by evaporation into the vacuum, by the frictional energy associated with the sliding process, or as a result of electron-induced desorption from the Auger electron beam. The electron beam effects are discussed later.

Because the ZDP was such a good boundary lubricant, no differences in friction and adhesive wear of the riders with the iron could be detected. The concentration of ZDP on the surface was reduced by diluting it with hexane. A 10 percent solution of ZDP was applied to the surface in the same manner as was done with the undiluted ZDP. An Auger spectrum of the iron disk with the diluted film is presented in figure 3. It is important to note that the hexane evaporates in the vacuum system leaving behind a thin film of ZDP on the metal surface. While a 10 percent solution is a higher concentration than is normally used in adding ZDP to oil, the film here is not replenished as it can be when an oil is used.

Auger peaks are seen in figure 3 for phosphorus, sulfur, carbon, and oxygen before sliding. It is of interest to note that even with a dilution of the additive it still completely masks the iron Auger peaks.

Sliding friction experiments were conducted with an aluminum rider rubbing against an iron disk surface in the presence of the diluted film. Friction and Auger data as functions of load are presented in figure 4. The friction data of figure 4 indicate that higher values are obtained with the diluted film at all loads. Furthermore, friction increasing with increased loading indicates greater and greater metal to metal contact. Increasing the load from 1200 to 1500 grams resulted in a drastic increase in the friction coefficient (0.4 to 1.0), a condition which reflects a significant interfacial change. The plot of the aluminum Auger peak intensities in figure 4 indicates the nature of that change. The amount of aluminum transferring to the iron increases with increasing load just as did the friction. Likewise, with the sudden increase in friction there was a sudden increase in the amount of aluminum transferred. The concentration of active ZDP elements continuously decreases with increasing load as indicated in figure 4.

The results of figure 4 lead to the conclusion that an increase in the friction coefficient is directly related to the amount of aluminum transfer. The high friction and metal transfer are caused by metal to metal contact. With the undiluted ZDP the friction coefficient was unaffected by load. This condition indicates an absence of metal to metal contact. With the diluted film, however, metal to metal contact continuously increased with load.

When aluminum slides on metals other than iron markedly different results are obtained. Rhodium is a chemically less surface active metal than iron. In figure 5 friction coefficients and Auger peak intensities are presented for rhodium and phosphorous as functions of load.

The data of figure 5 indicate that there is an increase in the friction coefficient with increases in load up to 600 grams. There is a corresponding increase in the rhodium peak intensities and a decrease in the phosphorous intensities. The Auger spectroscopy results are related. As the phosphorus from the ZDP is rubbed away with increasing load there is an increasing exposure of the rhodium disk surface in the contact area.

This results in higher measured friction coefficients because of the increased metal to metal contact.

Auger spectroscopy results for sulfur, carbon, and oxygen with changes in load on the rhodium disk yielded results very analogous to those results obtained in figure 4 with iron - that is, a continuous decrease with increased loading. Thus, phosphorus appears to be the key element in the ZDP lubrication of an aluminum to rhodium contact.

The relative Auger peak intensity of the disk material under the lubricating films appears to be a good indicator of friction behavior (see fig. 5). The experiments of figure 5 were repeated with a titanium disk substituted for the rhodium disk. The results of these experiments are presented in figure 6. Comparing the data of figure 6 with that of figure 5 shows that the behavior of the titanium disk is similar to that of the rhodium disk. The coefficient of friction varies as does the disk metal peak intensity.

Rhodium is a relatively chemically inactive metal while titanium is the most active of the transition metals. With the rhodium disk the friction coefficient was sensitive to the surface concentration of the phosphorus in the ZDP. For titanium the sensitivity was equal for all of the active elements in the ZDP. It is of interest to know whether phosphorus is the key element in the lubricating effectiveness of other metals. Experiments were therefore conducted with a tungsten metal, which is a transition metal intermediate in chemical activity between titanium and rhodium.

Friction data and Auger emission spectroscopy results for aluminum sliding on a tungsten disk containing a film of 10 percent ZDP at various loads are presented in figure 7. In figure 7 the zinc peak intensities are plotted in addition to the phosphorus, sulfur, oxygen, and carbon intensities.

The coefficient of friction of figure 7 increases with load as it did for iron in figure 4. As observed in figure 4 there is a decrease in the phosphorus, sulfur, oxygen, and carbon surface concentrations with an increase in load. The decrease is, however, slight over the entire load range.

Monitoring the zinc concentration with changes in load revealed that the zinc surface concentration decreased with an increase in load. Thus, while the friction coefficient increases with changes in load, the zinc surface concentration decreases markedly. With rhodium the coefficient of friction appeared to be sensitive to the phosphorus in the ZDP phosphate, while with the tungsten the zinc appears to be the critical surface active element in the ZDP.

Extreme care must be taken in monitoring Auger peak intensities for the zinc in the ZDP because it is sensitive to Auger electron beam induced desorption. Zinc is the only element in the ZDP observed to be sensitive to electron beam induced desorption. Prolonged exposure of the surface to the electron beam did not alter the surface concentration of phosphorus, sulfur, oxygen, or carbon. The effect on zinc, however, can be seen in figure 8.

The data of figure 8 indicate that with an increasing exposure time of the surface to the electron beam there is a decrease in the surface concentration of zinc. At sufficiently prolonged exposures, the zinc will disappear entirely from the Auger spectra. This was controlled in the data of figure 7 by taking the data at new locations on the disk surface each time after beam exposure.

Another disk material examined was molybdenum. This surface also reflected electron induced desorption of zinc. This effect, which is presented in the data of figure 9, is analogous to that obtained with tungsten (see fig. 8). The zinc is lost from the surface with increasing exposure.

While monitoring other elements on the molybdenum surface, the oxygen concentration is observed to change with load. Friction coefficient data and oxygen surface concentration as functions of load are presented in figure 10.

In figure 10 there is an increase in the friction coefficient at loads to 700 grams. Corresponding to that increase is an increase in the surface concentration of oxygen. This increase in oxygen is associated with the rubbing away of the ZDP and the exposure of the molybdenum oxide. It should be remembered that the residual surface oxides were not removed from the metal surfaces. Phosphorus, sulfur, and carbon are observed to decrease in peak intensity.

When the load reaches 800 grams there is a marked decrease in the surface concentration of oxygen. With this decrease there is an increase in the molybdenum Auger peak intensity indicating that, as the molybdenum oxide is worn away and molybdenum metal is exposed, there is an increase in the friction coefficient because of increased metal to metal contact. Thus, with the molybdenum disk the ZDP film is almost completely worn away. The tenacity of the film to this surface, therefore, is less than it is to the metals already described.

All the data presented thus far are for aluminum in contact with transition metals. Distinct and obvious differences in the surface behavior of ZDP are observed with the different transition disk metals. Since the effect of ZDP on nontransition metals was not known, it was decided to examine aluminum in contact with a copper disk surface containing a film of 10 percent ZDP in hexane.

Figure 11 is an Auger spectrum for the copper disk surface with a ZDP film before the initiation of sliding. The elements observed on the surface are phosphorus, sulfur, carbon, oxygen, and copper. Copper Auger peaks are visible in figure 11 through the ZDP film. As a comparison, figure 3 shows that the film completely covered the iron surface and that iron peaks were not detected though both films were applied in an identical manner. Such a condition indicates a difference in affinity of the ZDP for the two metals with the greater affinity being to the iron.

With no further information than a comparison of the Auger spectra of figure 11 with that of figure 3 it might be anticipated that the ZDP will not lubricate copper as ef-

fectively as it does iron. Friction and Auger results obtained during friction experiments indicate that this is, in fact, the case.

The data of figure 12 reveal that even at the relatively modest load of 100 grams the coefficient of friction for the aluminum rider against the copper disk surface in the presence of the ZDP is high. With an increase in load to 200 grams the coefficient of friction rises to 2.5, obvious metal to metal contact.

Auger spectra for the aluminum peak intensity indicate the transfer of aluminum to the copper surface. This can be seen in the data presented in figure 12 and in the Auger spectrum of figure 13 which indicates the presence of aluminum.

The sliding speeds employed in this investigation were relatively modest. It must be remembered that changes in sliding velocity will alter the interfacial energy and this in turn will affect the observed chemical activity of the ZDP with the metal surfaces.

CONCLUDING REMARKS

Based on the results obtained during the friction experiments with aluminum in sliding contact with various metals in the presence of zinc dialkyldithiophosphate (ZDP) films and using Auger emission spectroscopy to monitor surface chemistry in the wear tracks, the following conclusions are drawn:

1. The active element in ZDP which affords surface protection is a function of the metals being lubricated. For example, with aluminum sliding on rhodium it was phosphorus, while with aluminum sliding on tungsten it was zinc. With iron no distinction was noted among the active elements and friction behavior.

2. ZDP is more effective in lubricating some metals than others. It is much more effective for the transition metals iron, titanium, tungsten, molybdenum, and rhodium than it is for the nontransition metal copper.

3. The zinc in ZDP is sensitive to electron induced desorption while the other elements are not. This condition indicates that the other elements have greater binding strength to the metal.

Lewis Research Center,
National Aeronautics and Space Administration,
Cleveland, Ohio, March 23, 1979,
506-16.

REFERENCES

1. Rounds, F. G.: Additive Interactions and Their Effect on the Performance of a Zinc Dialkyl Dithiophosphate. *Trans. ASLE*, vol. 21, no. 2, Feb. 1978, pp. 91-101.
2. Rowe, Carleton N.; and Dickert, Joseph J., Jr.: The Relation of Antiwear Function to Thermal Stability and Structure for Metal O, O-Dialkylphosphorodithioates. *Trans. ASLE*, vol. 10, no. 1, Jan. 1967, pp. 85-90.
3. Dickert, Joseph J., Jr.; and Rowe, Carleton N.: The Thermal Decomposition of Metal O, O-Dialkylphosphorodithioates. *J. Org. Chem.*, vol. 32, no. 3, Mar. 1967, pp. 647-653.
4. Hanneman, Walter W.; and Porter, Roger S.: The Thermal Decomposition of Dialkyl Phosphates and O, O-Dialkyl Dithiophosphates. *J. Org. Chem.*, vol. 29, no. 10, Oct. 1964, pp. 2996-2998.
5. Gallopoulos, Nicholas E.: Thermal Decomposition of Metal Dialkyldithiophosphate Oil Blends. *Trans. ASLE*, vol. 7, no. 1, Jan. 1964, pp. 55-63.
6. Rowe, Carleton N.; and Dickert, Joseph J., Jr.: The Relation of Antiwear Function to Thermal Stability and Structure for Metal O, O-Dialkylphosphorodithioates. *Trans. ASLE*, vol. 10, no. 1, Jan. 1967, pp. 85-90.
7. Heilweil, I. J.: Association Studies of Metal O, O-Dialkyl Phosphorodithioates. *Am. Chem. Soc., Div. Petrol. Chem., Preprints*, vol. 10, no. 4, 1965, pp. D19-D31.

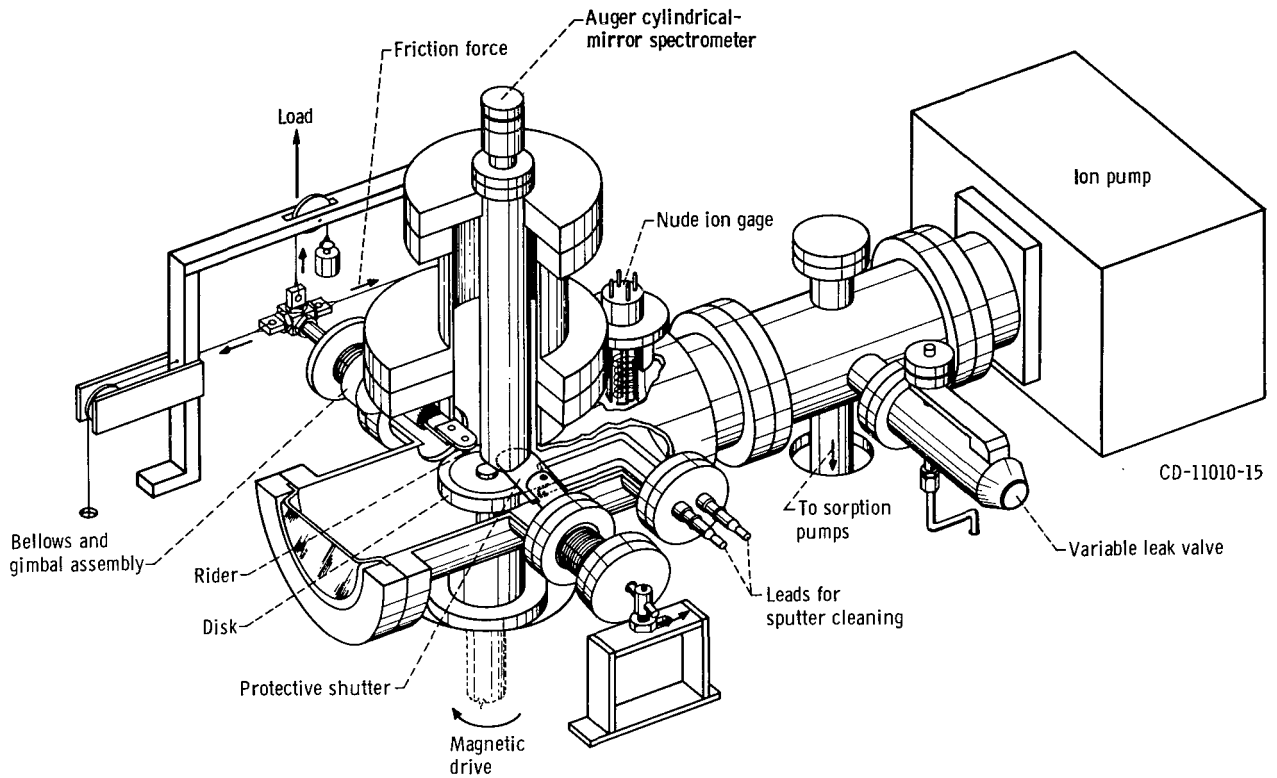

Figure 1. - Friction apparatus with Auger spectrometer.

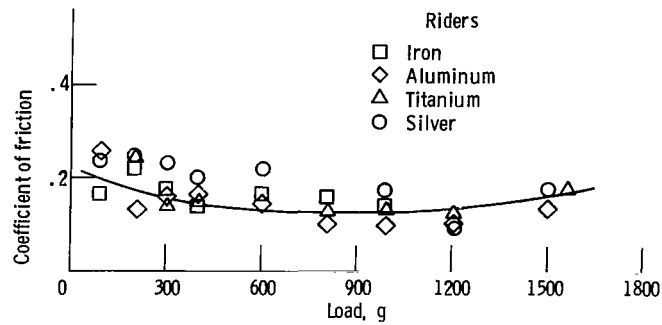

Figure 2. - Coefficient of friction for various riders sliding on iron disk containing thin film of zinc dialkyldithiophosphate. Sliding velocity, 30 centimeters per minute; temperature, 23° C.

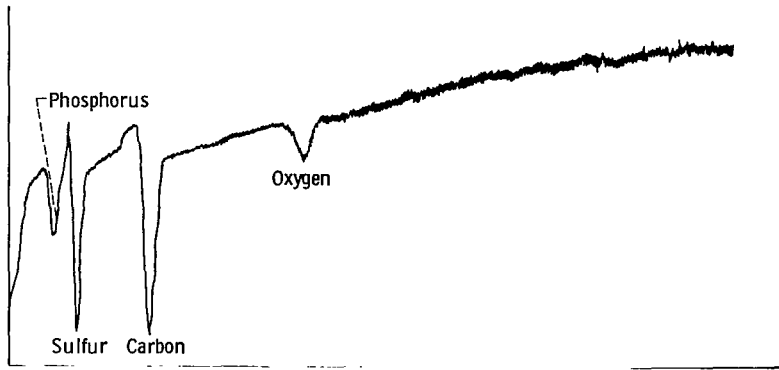

Figure 3. - Auger emission spectrum for iron disk surface containing thin film of 10 percent zinc dialkyldithiophosphate in hexane.

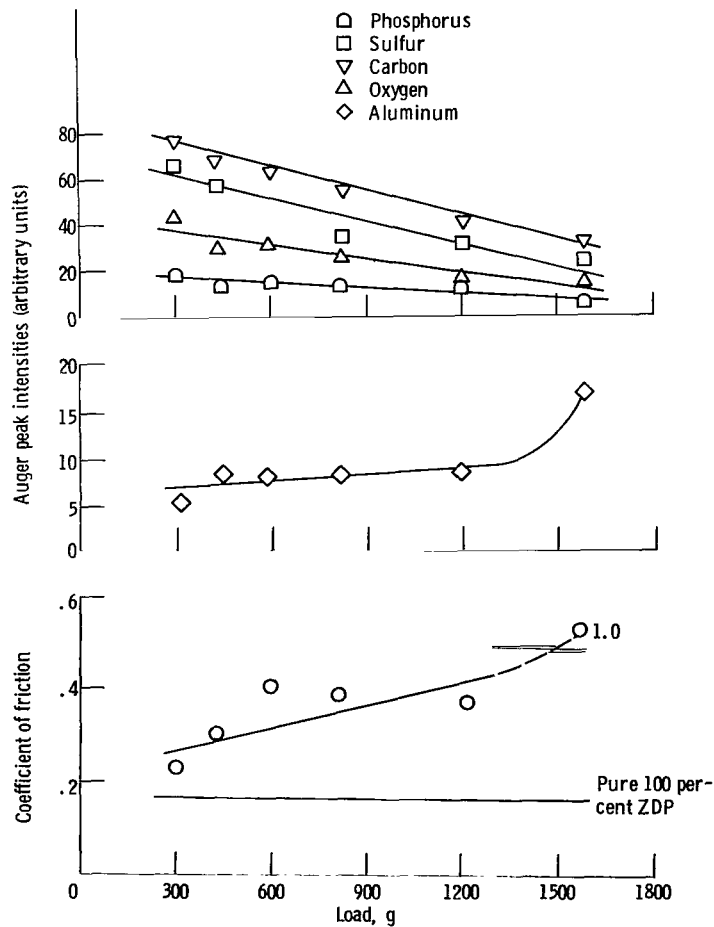

Figure 4. - Friction and Auger spectroscopy data for aluminum sliding on iron with thin film of 10 percent zinc dialkyldithiophosphate (ZDP) in hexane. Sliding velocity, 30 centimeters per minute; temperature, 23° C.

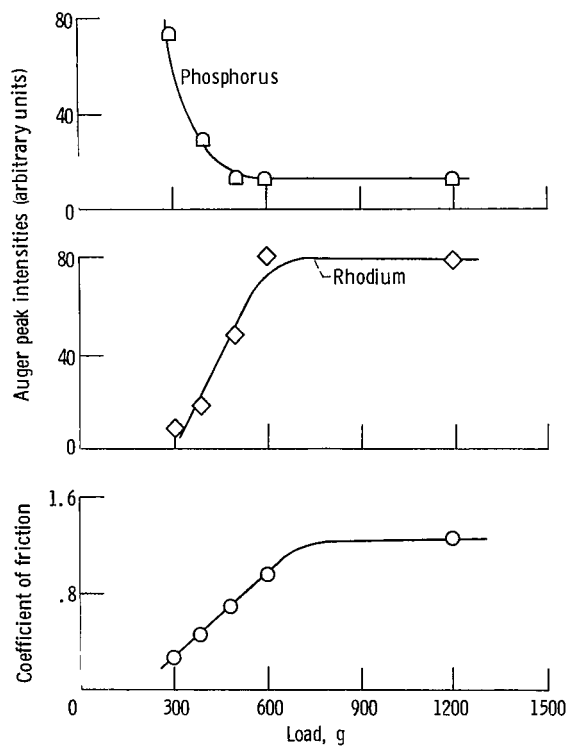

Figure 5. - Friction and Auger spectroscopy data for aluminum sliding on rhodium with thin film of 10 percent zinc dialkyldithiophosphate in hexane. Sliding velocity, 30 centimeters per minute, temperature, 23^o C.

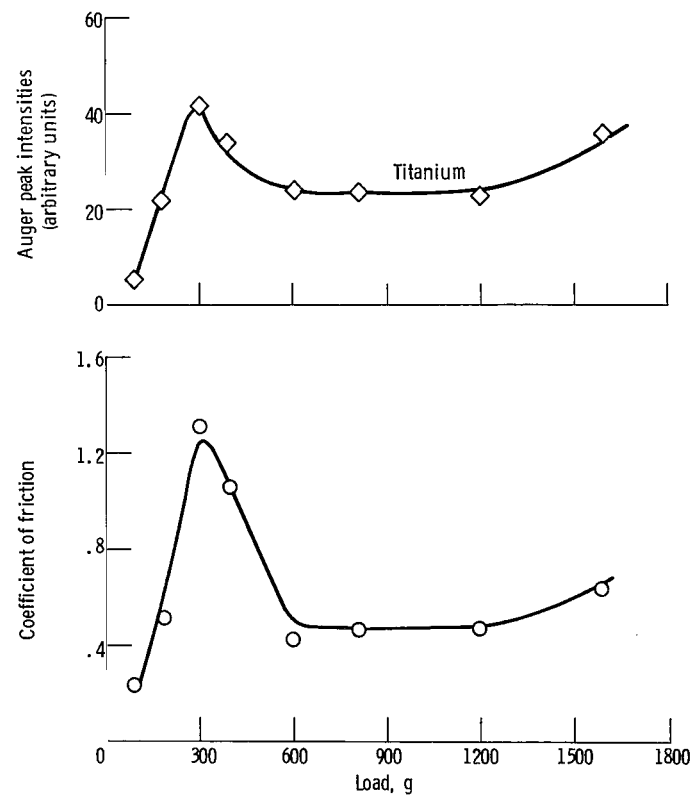

Figure 6. - Coefficient of friction and titanium Auger peak intensities from friction experiment with aluminum sliding on titanium disk lubricated with thin film of 10 percent zinc dialkyldithiophosphate. Sliding velocity, 30 centimeters per minute, temperature, 23^o C.

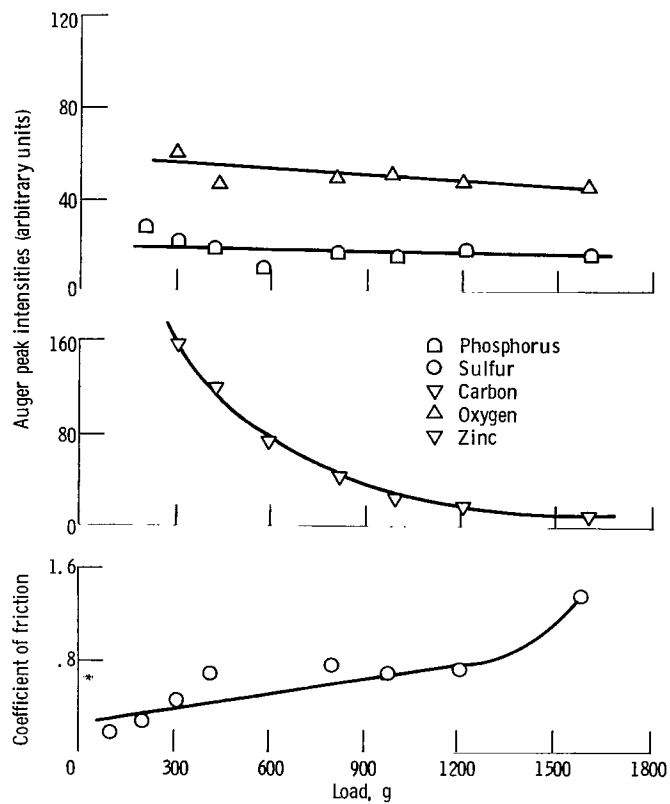

Figure 7. - Friction and Auger spectroscopy data for aluminum sliding on tungsten with thin film of 10 percent zinc dialkyldithiophosphate in hexane. Sliding velocity, 30 centimeters per minute, temperature, 23^o C.

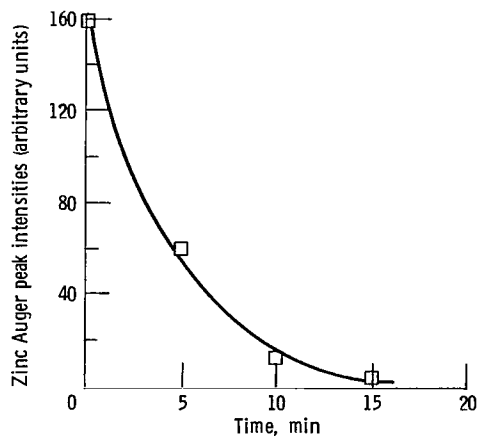

Figure 8. - Electron beam induced desorption of zinc from tungsten disk wear track. Rider, aluminum; load, 300 grams; temperature, 23^o C; Auger electron beam, 10 microamperes and 1360 volts; lubricant, thin film of 10 percent zinc dialkyldithiophosphate in hexane.

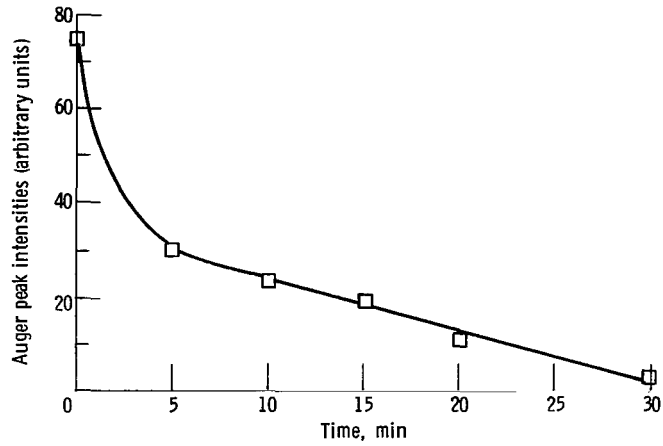

Figure 9. - Auger electron beam induced desorption of zinc from wear track on molybdenum disk. Source of zinc, 10 percent dialkyldithiophosphate thin film on disk surface. Rider, aluminum; load, 1600 grams; sliding velocity, 30 centimeters per minute; temperature, 23^o C.

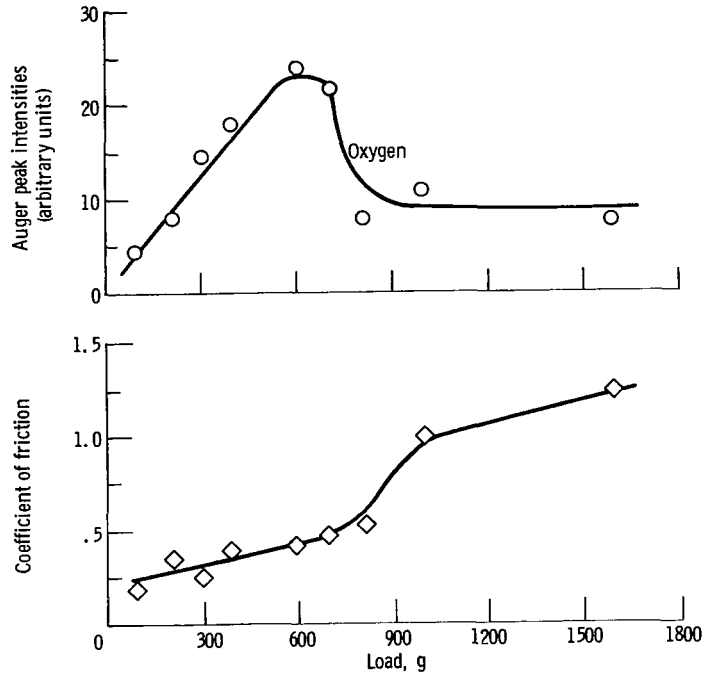

Figure 10. - Coefficient of friction and oxygen Auger peak intensity for aluminum rider sliding on molybdenum disk containing thin film of zinc dialkyldithiophosphate. Sliding velocity, 30 centimeters per minute; temperature, 23^o C.

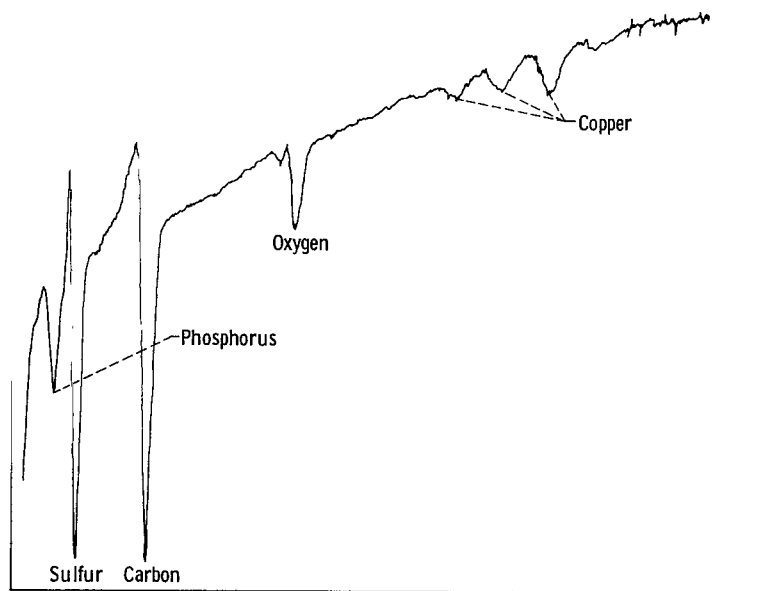

Figure 11. - Auger emission spectrum for copper surface containing thin film of 10 percent zinc dialkyldithiophosphate in hexane.

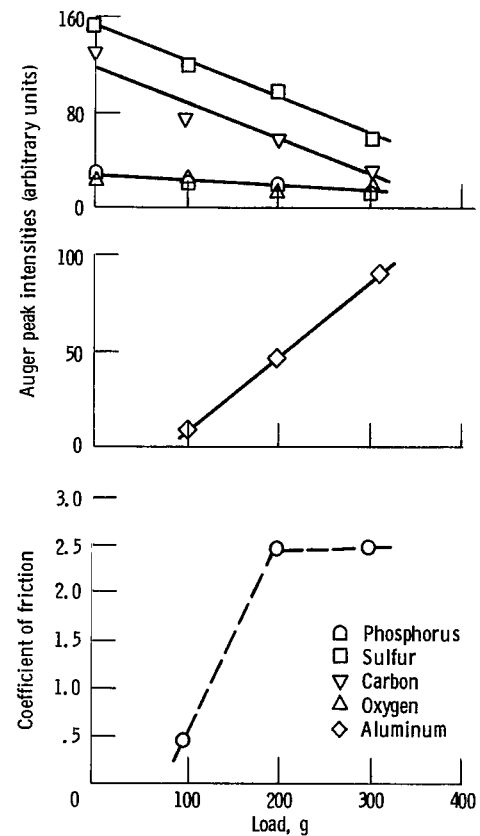

Figure 12. - Friction and Auger spectroscopy data for aluminum sliding on copper with thin film of 10 percent zinc dialkyldithiophosphate in hexane. Sliding velocity, 30 centimeters per minute; temperature, 23° C.

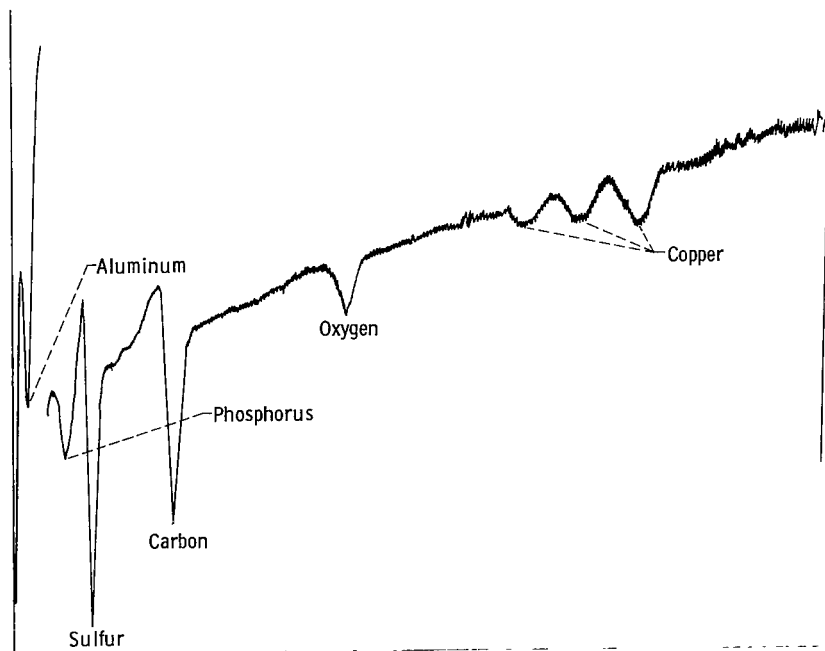

Figure 13. - Auger emission spectra for aluminum rider sliding on copper disk containing thin film of 10 percent zinc dialkyldithiophosphate in hexane. Load, 300 grams; sliding velocity, 30 centimeters per minute; temperature, 23^o C.

1. Report No. NASA TP-1489	2. Government Accession No.	3. Recipient's Catalog No.
4. Title and Subtitle AUGER SPECTROSCOPY ANALYSIS OF LUBRICATION WITH ZINC DIALKYLDITHIOPHOSPHATE OF SEVERAL METAL COMBINATIONS IN SLIDING CONTACT		5. Report Date July 1979
7. Author(s) Donald H. Buckley		6. Performing Organization Code
9. Performing Organization Name and Address National Aeronautics and Space Administration Lewis Research Center Cleveland, Ohio 44135		8. Performing Organization Report No. E-9909
12. Sponsoring Agency Name and Address National Aeronautics and Space Administration Washington, D. C. 20546		10. Work Unit No. 506-16
15. Supplementary Notes		11. Contract or Grant No.
16. Abstract <p>Sliding friction experiments were conducted with aluminum and other riders rubbing on disks of various elemental metals in the presence of a thin film of zinc dialkyldithiophosphate (ZDP). Auger emission spectroscopy (AES) was used to in situ monitor the changes in surface chemistry with rubbing under various loads. The metal disks examined included iron, titanium, rhodium, tungsten, molybdenum, and copper. The results of the study indicate that for equivalent films of ZDP the film is a more effective lubricant for some metals than it is for others. The important active element in the compound varies with the metal lubricated and is a function of metal chemistry. The zinc in the ZDP is susceptible to electron beam induced desorption.</p>		13. Type of Report and Period Covered Technical Paper
17. Key Words (Suggested by Author(s)) Oil additives Zinc dialkyldithiophosphate Auger spectroscopy Lubrication		14. Sponsoring Agency Code
19. Security Classif. (of this report) Unclassified		18. Distribution Statement Unclassified - unlimited STAR Category 27
20. Security Classif. (of this page) Unclassified	21. No. of Pages 18	22. Price A02

National Aeronautics and
Space Administration

Washington, D.C.
20546

Official Business

Penalty for Private Use, \$300

SPECIAL FOURTH CLASS MAIL
BOOK

Postage and Fees Paid
National Aeronautics and
Space Administration
NASA-451



1 1 1U,C, 070679 S00903DS
DEPT OF THE AIR FORCE
AF WEAPONS LABORATORY
ATTN: TECHNICAL LIBRARY (SUL)
KIRTLAND AFB NM 87117

NASA

POSTMASTER: If Undeliverable (Section 158
Postal Manual) Do Not Return
