

JPL PUBLICATION 79-35, VOLUME II

{NASA-CR-158769} PROCEEDINGS OF THE
DISTRIBUTION AUTOMATION AND CONTROL WORKING
GROUP. VOLUME 2: PROCEEDINGS (Jet
Propulsion Lab.) 127 p HC A03/MF A01

N79-27659

Unclas
29237

CSCL 10B G3/44

Distribution Automation and Control
on the Electric Power System

Proceedings of the Distribution Automation and Control Working Group

Volume II: Proceedings

Baltimore, Maryland
November 20-22, 1978



March 1979

Prepared for
U.S. Department of Energy
Through an agreement with
National Aeronautics and Space Administration
by
Jet Propulsion Laboratory
California Institute of Technology
Pasadena, California



JPL PUBLICATION 79-35, VOLUME II

Distribution Automation and Control
on the Electric Power System

Proceedings of the Distribution
Automation and Control
Working Group
Volume II: Proceedings

Baltimore, Maryland
November 20-22, 1978

March 1979

Prepared for
U.S. Department of Energy
Through an agreement with
National Aeronautics and Space Administration
by
Jet Propulsion Laboratory
California Institute of Technology
Pasadena, California

Prepared by the Jet Propulsion Laboratory, California Institute of Technology, for the U.S. Department of Energy, Division of Electric Energy Systems, through an agreement with the National Aeronautics and Space Administration.

This report was prepared as an account of work sponsored by the United States Government. Neither the United States nor the United States Department of Energy, nor any of their employees, nor any of their contractors, subcontractors, or their employees, makes any warranty, express or implied, or assumes any legal liability or responsibility for the accuracy, completeness or usefulness of any information, apparatus, product or process disclosed, or represents that its use would not infringe privately owned rights.

FOREWORD

This document consists of two volumes: Volume I, the Executive Summary, and Volume II, the detailed Proceedings. Volume I was prepared from Volume II and is being more widely distributed. Copies of Volume I (or additional copies of Volume II) may be obtained from Ralph Caldwell, 507-108, DAC Project Manager, Jet Propulsion Laboratory, California Institute of Technology, 4800 Oak Grove Drive, Pasadena, California 91103 (telephone: (213) 577-9162, (FTS) 792-9162).

ACKNOWLEDGEMENT

The efforts of all of the participants before, during, and after the DAC Working Group Meeting are gratefully acknowledged. We are especially grateful to D. Mohre, W. Blair, and F. Schweppe for presentations and to the session chairmen: J. Blose, R. Ferber, O. Hill, J. Hunter, H. Kitching, K. Klein, G. Lokken, W. Prince, T. Reddoch, and F. Schweppe.

Basic documentation was provided by P. Klock, D. Evans, and M. Van Horn of ESC Energy Corporation. Arrangements for the meeting were made by M. Fowler and D. Osman of the Jet Propulsion Laboratory.

R. Caldwell of JPL was responsible for the preparation of meeting materials and the overall conduct of the meeting under the guidance and direction of P. Overholt of the Department of Energy. Other members of JPL and DOE provided valuable contributions to the preparation of materials and to the conduct of the meeting.

DAC WORKING GROUP DOCUMENTATION PROCEDURE

It is important to the interpretation of the results presented in this document to understand how it was prepared. It is not a transcript of the DAC Working Group meeting, but rather a compilation of the statements and recommendations made by participants. The meeting consisted of panel discussions, informal presentations, and small group discussion sessions. Information was collected in the form of written notes, tape recordings and transcripts, questionnaires, and submittals from participants. These source documents were collected by the contracted documentation manager, ESC Energy Corporation, for preparation of the final documents. The raw data from the various sources was loosely organized; consisting as it did of a collection of individual and group comments and questions. The documentation contractor then performed the task of distilling, organizing, and transforming this raw data into a brief statement of the issues and recommendations made by the Working Group participants. The tape recordings were retained as a back-up resource to assure that the final documents accurately reported the activities and conclusions of the meeting without editorial inaccuracies.

It is important to recognize that the Working Group activities led to statements of issues, uncertainties, and needed actions which may or may not be consistent with the views of each of the organizations represented. These statements are included in the final documentation as presented; no attempt is made to point out or reconcile inconsistencies.

7.1.1	Revised Definition Statement - Load Management . . .	7-1
7.1.2	Definition Statement - Unconventional Energy Resources	7-2
7.1.3	Major Statements	7-3
7.1.4	Discussion	7-4
7.2	DISTRIBUTION SYSTEM MANAGEMENT WORKING SESSION	7-5
7.2.1	Revised Definition Statement - Distribution System Management	7-6
7.2.2	Major Statements	7-6
7.2.3	Discussion	7-7
7.3	PREVENTIVE, EMERGENCY, AND RESTORATIVE STATE CONTROL WORKING SESSION	7-8
7.3.1	Revised Definition Statement - Preventive, Emergency, and Restorative State Control	7-8
7.3.2	Major Statements	7-10
7.3.3	Discussion	7-11
7.4	DAC FUNCTIONAL REQUIREMENTS WORKING SESSION	7-12
7.4.1	Definition Statement - DAC Functional Requirements	7-12
7.4.2	Case System Exercise	7-13
7.4.3	Summary of Results	7-16
7.4.4	Major Key Issues	7-17
7.4.5	General	7-18
7.5	ECONOMIC AND INSTITUTIONAL ISSUES WORKING SESSION	7-19
7.5.1	Revised Definition Statement - Economic and Institutional Issues	7-19
7.5.2	Major Statements	7-20
7.5.3	Discussion	7-21

7.6	DAC CONTROL HIERARCHY WORKING SESSION	7-24
7.6.1	Definition Statement - DAC Control Hierarchy	7-24
7.6.2	Scope of Session	7-25
7.6.3	Working Outline	7-25
7.6.4	Session Worksheets	7-28
7.6.5	Discussion and Major Statements	7-31
7.7	IMPACT ON SYSTEM DESIGN WORKING SESSION	7-32
7.7.1	Definition Statement - Impact on System Design	7-32
7.7.2	Major Statements	7-33
7.7.3	Discussion	7-34
7.8	COMMUNICATION ALTERNATIVES WORKING SESSION	7-37
7.8.1	Definition Statement - Communication Alternatives	7-37
7.8.2	Major Statements	7-38
7.8.3	Discussion	7-38
7.9	NEW SOURCE INTEGRATION WORKING SESSION	7-41
7.9.1	Definition Statement - New Source Integration	7-42
7.9.2	Major Statements	7-42
7.9.3	Discussion	7-43
APPENDIXES		
A	CURRENT PROJECTS AND ACTIVITIES	A-1
B	PARTICIPANTS - DAC WORKING GROUP MEETING	B-1
C	AGENDA - DAC WORKING GROUP MEETING	C-1
D	PRE-MEETING MATERIALS (FACT SHEETS)	D-1
E	BIBLIOGRAPHY: RECENT RELEVANT PUBLICATIONS AND PAPERS	E-1

Figures

7-1	Case I Distribution Circuit	7-14
7-2	Case II Distribution Circuit	7-15

Table

7-1	Decision-Making System: Normal Mode	7-29
7-2	Decision-Making System: Emergency Mode - Bulk System, Distribution System	7-30
7-3	Decision-Making System: Restoration Mode (Distribution System Only)	7-31

SECTION 1

INTRODUCTION

The meeting of the Distribution Automation and Control (DAC) Working Group was held at Hunt Valley Inn, Baltimore, Maryland, on November 20-22, 1978. It was sponsored by the Department of Energy (DOE), Division of Electric Energy Systems, and was conducted by the Jet Propulsion Laboratory (JPL). Approximately 35 people attended, among them electric utility company representatives, manufacturer's representatives (from companies having power distribution systems experience), and representatives of the Electric Power Research Institute (EPRI), DOE, JPL, and Oak Ridge National Laboratory (ORNL) (see Appendix B).

The meeting was held to provide a forum in which electric utilities could communicate with each other, with DOE, and with DOE's contractors regarding research, development, and demonstration efforts to apply DAC to the electric power system (see Appendix C, Agenda). In these discussions emphasis was to be placed on identifying the priorities and needs for DAC development.

SECTION 2

PURPOSE

The Distribution Automation and Control (DAC) Working Group was brought together to reach a common understanding on:

- (1) The key issues and uncertainties to be resolved prior to the economic application of Distribution Automation and Control Systems to Load Management, Distribution System Management, Emergency State Control*, and Unconventional Energy Resources.
- (2) The existing state of the art in DAC, and current research, development, and demonstration.
- (3) Specific requirements for further research, development, and demonstration in the area of DAC.

*This term was later revised by the Working Group Session.

SECTION 3

APPROACH

The Working Group gathered together individuals and organizations working in various aspects of Distribution Automation and Control including those clearly related to the Technical Motivations (Load Management, Distribution System Management, Emergency State Control, and Unconventional Energy Resources). The meeting consisted of a number of introductory presentations, panel and plenary sessions, discussions, and nine working sessions of interactive discussions. Through use of a workshop format, the participants shared experiences, concerns, ideas, and insights, having the advantage of hearing and responding to others with similar interests. The use of a workshop structure, procedures, and materials provided a basic framework for discussions. The meeting's activities revolved around the four Technical Motivations and six Areas of Issues.

3.1 TECHNICAL MOTIVATIONS

Technical Motivations are the broad functions to which DAC can be applied to enhance operation of the electric utility system.

- (1) Load Management.
- (2) Distribution System Management.
- (3) Preventive, Emergency, and Restorative State Control*.
- (4) Unconventional Energy Resources Management.

3.2 AREAS OF ISSUES

Areas of Issues are groups of interrelated questions or problems that must be resolved before DAC can be applied to the Technical Motivations.

- (1) Economic and Institutional Issues
- (2) DAC Control Hierarchy.
- (3) Communication System Alternatives
- (4) DAC Impact on System Design.
- (5) DAC Functional Requirements.
- (6) New Source Integration.

*As renamed and redefined by Working Group Session.

SECTION 4

OVERALL RESULTS AND STATEMENTS OF THE DAC WORKING GROUP

During the course of the interactive Working Group meetings, it became clear that there were a number of recurrent issues, questions, recommendations, and general statements. A review of Sections 7.1 through 7.9 reveals that even in the context of different topics, certain concerns were being voiced over and over again. This section summarizes the major statements of most concern to the workshop participants. Recommendations regarding the next important steps in DAC development, as discussed by the participants in the summary session at the end of the workshop, are listed in Section 5.

Economics

The cost effectiveness of each DAC component and the overall system must be demonstrated credibly. A full system field demonstration would be quite helpful in this endeavor. Economic justification is almost always a prerequisite for implementation. Exceptions may be applications that are forced by absolute functional necessity or regulation.

Public Awareness and Education

The public sector is not well informed about the advent of DAC technology and its potential effects, especially in load management. Each utility should accept responsibility for educating its customers and preparing them for any changes.

Communications and Reliability

The communication system is perhaps the most vital element of the DAC system. Since it transfers all of the metering information, data, equipment commands, etc., it must be extremely reliable. Work in developing improved communication alternatives must continue. One need is readily identifiable: more frequency bands should be allocated to electric utilities for use in load management and distribution automation.

DAC Specification by Utilities

DAC systems must be specifically designed on a case-by-case, utility-by-utility basis to meet individual needs. Therefore, there must be a free exchange of system requirements between utilities and researchers and manufacturers, to assure that systems developed for the "general case" are appropriate for the specific case. Clearer identification of DAC functions is required.

Regulation With Utility Input

Regulations can drastically affect new technology developments, such as DAC technology, especially when applied in the utility industry. Utilities therefore need to assume a more active role in communicating needs to regulators and in monitoring new legislation.

Emergency Conditions - A Top Priority

Much discussion time was spent on what a DAC system should do in certain preventive, emergency, and restoration situations. Even though emergencies account for only a small fraction of any system's operating time, DAC systems should be designed with emergency response as a chief concern.

New Challenges from Dispersed Storage and Generation

As new energy technologies, cogeneration, and dispersed storage begin to represent a significant total power source, the utilities must find ways of accommodating these dispersed sources. Many issues are involved in a successful implementation, including interface designs and control hierarchies for the dispersed units, and some of these issues must be dealt with soon. The ownership of dispersed generation units is a significant concern and must be taken into consideration in power control systems designs. Thus, well defined role statements for privately owned units are needed for both normal and emergency operations.

Minimization of Social Impacts

DAC development should be aimed at minimizing forced social changes by the consumer. The goal should be to use DAC to more effectively and efficiently meet all of the public's power needs without requiring alterations in life styles. At the least, a choice of service options should be offered to the customer.

New Effects on Reserve Requirements

How DAC will affect reserve requirements is not known and should be established.

Standard Means of Evaluation and Definitions

The industry needs a set of standards, including standardized methodologies, for economic and engineering feasibility analyses of DAC. There is also a need for standardization of the new, specialized terms accompanying the growth of this new technology.

Specifically, terms such as "load management" and "distribution automation and control" appear to mean different things to different persons in the industry.

Relationship of DAC Systems to Distribution System Management

As a result of the Working Group's efforts, the relationship of DAC to overall management and operation of distribution systems was clarified. If distribution system management is defined as the control and direction of the planning, design, construction, operation, and maintenance of the distribution system to provide safe, economical, high quality service to the customer, then DAC systems are those systems which provide for communications and control in support of distribution system management. Thus, a DAC system monitors and controls the total distribution system, including any dispersed storage and generation, and load control devices or subsystems, under all power system states.

Data Needs

More data on customer reactions to load control, and on the real results of load deferral, etc., is needed before load management and related DAC systems can be adequately designed.

Independent RD&D

There is a great deal of activity in DAC and related technology within the industry, but implications from these numerous activities are not usually considered in an overall, comprehensive fashion.

SECTION 5

SUMMARY SESSION

On the last day of the conference, nearly all of the participants gathered to share their thoughts on what the DAC Working Group had accomplished, where it could have been improved, and what the next steps should be in the ongoing development of DAC technology.

Opening Remarks - David L. Mohre, DOE

The session began with a few remarks by David L. Mohre of the Department of Energy, on his view of the accomplishments of the DAC Working Group as seen from the DOE perspective. A synopsis of Mr. Mohre's comments is given here.

At the end of a meeting such as the DAC Working Group, one must ask if the desired objectives were met. We are pleased that this workshop has been reasonably successful in meeting its objectives. The use of discussion sessions, panels, presentations, and a mountain of paperwork, has helped us more fully understand the issues facing DAC development and what priority they represent to the industry. We felt it was appropriate at this time to hold such a meeting as an opportunity to "check-in" with the industry after nearly 3-1/2 years and approximately \$7 million dollars of effort have been expended on RD&D related to DAC, by DOE and EPRI combined. The feedback provided during the workshop is of great value to us.

The workshop was also successful in that it provided an excellent forum for the utility companies to converse with one another and discover what is being done in DAC development by other companies and organizations. The participants at this workshop have commented that this opportunity for interaction has been quite beneficial and should be continued. We at DOE recognize that benefit and support a continued dialogue within the power community.

DOE will continue its efforts to assist the utility industry through DAC, RD&D and will, as a result of this meeting, make a special effort in

- Dealing with regulators and regulations.
- Gathering and locating information.
- Maintaining an ongoing dialogue on DAC developments within the industry.

We will also produce a document from the results of the DAC Working Group which will be of use to the participants and interested members of the utility community. As always, we welcome your comments and will do everything we can to respond to your requests.

Participant Comments

The major comments made by the participants during this session are summarized here:

- (1) Future meetings such as the DAC Workshop would be helpful, especially in continuing to find out what other companies are doing in DAC. Specific questions should be addressed at other meetings such as:
 - (a) Regulations - What will they be and how should utilities influence their formation?
 - (b) Controllable loads - What are the best types of DAC applications especially related to load management?
 - (e) What is a feasible standard approach for assessing economic feasibility of these systems?
 - (c) What are DOE contractors (other than JPL and ORNL) doing in DAC, and what input should they receive from the utility community?
 - (e) How will new forms of energy theft and system tampering by use of advanced electronics be dealt with? What is the potential impact of such thievery?
 - (f) Should DAC systems be integrated with control of other utilities such as gas and water? Perhaps a joint meeting would be appropriate.
- (2) Formal or informal working groups (ad hoc, EEI, etc.) should be formed to establish industry wide definitions of "new" terms in the DAC field. Particularly important definitions include
 - (a) Load management.
 - (b) Dispersed storage and generation.
 - (c) Emergency conditions.
 - (d) DAC.
 - (e) DAC communications.
- (3) A common catchall term should be agreed upon which embraces the entire field so as to avoid the use, interchangeably, of the terms automatic meter reading, load management, or DAC as the appropriate title.

- (4) Since the task of developing DAC is immense, development must be carried out in a number of areas in parallel. One possible way of organizing DAC development would be to divide it into three areas:
- (a) Technology development (hardware and component design and costs).
 - (b) Economics (cost/benefit analysis).
 - (c) Public acceptance (surveying, educating, and preparing customer for DAC).

Some organization should be designated to oversee the formation of multidisciplinary working groups for each of these three (or more) areas.

- (5) More system demonstrations are needed, particularly a totally integrated DAC system for meter reading, time-of-day rate management, load management, emergency control, integration of dispersed storage and generation, etc.
- (6) The DAC Working Group, especially the chairmen, should be regularly contacted by DOE, JPL, and ORNL regarding future developments in the government's research program.

Most of the participants felt that the DAC Working Group meeting was generally beneficial to the utility and government communities. They felt that such a forum was necessary for the realistic application of DAC potential within the utility industry and for utility input to other development oriented organizations. The reason that the meeting did not produce many specific, detailed economic or engineering conclusions was understood and accepted by most participants. It was successful in initiating the dialogue necessary to properly manage the development of DAC technology. The DAC Working Group meeting may therefore be called a successful beginning, but only a beginning.

SECTION 6

PRESENTATIONS

During the DAC Working Group meeting, a number of presentations were made as foundations to the interactive discussion sessions.

The first four presentations (Sections 6.1, 6.2, 6.3, 6.4) were given during the first few hours of the Working Group meeting to act as an introduction to the topic of DAC.

The fifth presentation (Section 6.5) was an informal after-dinner talk to familiarize the participants with a rapidly growing unconventional energy resource technology: solar power technology.

6.1 DOE OVERVIEW

David L. Mohre, Chief, Load Management Branch*
Division of Electric Energy Systems
United States Department of Energy

NOTE

As the DOE representative sponsoring the Distribution Automation and Control (DAC) Working Group, Mr. Mohre provided an informal description of DOE's involvement and interest in DAC. Below is a brief synopsis of the major points contained in his comments.

The DAC Working Group was called as a small, informal meeting, by invitation only. The size was kept small, despite much interest in attendance, in order to maximize interaction among the participants and permit a good dialogue between government, the utility industry, researchers, and some manufacturers. The meeting was sponsored by the Load Management Branch within the Division of Electric Energy Systems of the Department of Energy.

The Load Management Branch's task is basically research, development, and demonstration of advanced power systems, not regulation or policy formation. Members of the group have extensive utility industry experience and are thus quite competent in the major responsibilities of developing R&D objectives and managing research contracts. Some research is actually performed "in-house" by government laboratories. Oak Ridge National Laboratory, of nuclear power fame, is

*Position and title as of the date of the Working Group meeting.

responsible for power systems studies in load management and dispersed storage and generation, as well as many demonstration projects.

The Jet Propulsion Laboratory, known for its efforts in unmanned space flight and communications developments, is working in distribution automation and control. Consequently, JPL is the primary sponsor of this DAC Working Group. As technical people and researchers DOE also works quite closely with the Electric Power Research Institute (EPRI). We have interests and operations similar to those of EPRI; however, EPRI is working primarily for the utility industry's concerns, and DOE operates from the perspective of national energy concerns. These areas do overlap, so cooperation to avoid redundant efforts is carried on through sharing information and performing joint DOE/EPRI projects.

The DOE involvement in load management and distribution automation and control is directed at four major objectives:

- (1) Improved overall system efficiency in the use of both capital and energy.
- (2) Increased market penetration of coal, nuclear, and renewable domestic energy sources.
- (3) Reduced reserve requirements in both transmission and generation.
- (4) Increased reliability of service to essential loads.

It should be noted that these program objectives do not include an overall reduction in power generation or consumption, nor do they advocate that the public be required, or even requested, to alter its lifestyle by radical methods of conservation or socioeconomic change.

In the past, power system planning, simply stated, dealt with the production and delivery of power. The analysis that was performed looked, technically and economically, at the generation, transmission, and distribution components of the total system. Load management, by means of DAC systems, extends the planning process past production and delivery to include energy use. We must still justify the system technically and economically, but we must also inspect the energy forms involved from the national interest point of view. In addition, the added components of control and communications and energy storage in the delivery stage of power production must now be considered.

It is this new approach to power planning for advanced utility systems that is being considered in the DOE program. Therefore, this meeting was called to solicit the input of the industry to assure that DAC development is properly managed to meet the demands and needs of our future utility systems.

EPRI OVERVIEW

Dr. William E. Blair, Project Manager
Electrical Systems Division, EPRI

NOTE

Dr. Blair represented the Electric Power Research Institute (EPRI) at the DAC Working Group and reviewed EPRI's involvement in DAC-related research. His comments particularly focused on the development of communications systems and the joint DOE/EPRI demonstration program. The highlights of his slide presentation are synopsized here.

EPRI has developed a listing of requirements for distribution automation systems. The required functions include

- Fault isolation and control.
- Distribution feeder switching/sectionalizing.
- Capacitor switching.
- Voltage regulation and control.
- Substation equipment control and metering.
- Customer load control.
- Time-of-day.
- Remote meter reading.

These elements provide the foundation for the development and analysis of advanced distribution systems.

EPRI has made particularly extensive efforts in the area of the communication systems required to support and operate distribution automation and control systems. EPRI and DOE have chosen three communications concepts to test. These concepts are power line carrier (PLC), radio carrier (RC), and telephone carrier (TC). Each of these types of systems have various advantages and disadvantages, listed below:

Advantages	Disadvantages
POWER LINE CARRIER	
Owned and controlled by utility	Utility system must be conditioned Considerable auxiliary equipment Communication system fails if poles go down
RADIO CARRIER	
Owned and controlled by utility Point-to-point communication Terminal equipment only	Subject to interference by buildings and trees
TELEPHONE CARRIER	
Terminal equipment only Carrier maintained by phone company	Utility lacks control Ongoing tariff costs New telephone drops must be added Installation requires house wiring Communication system fails if poles go down

EPRI is currently involved in a joint demonstration project with DOE involving five different utility-manufacturer teams. Three of these test systems are of the PLC type and one each of the RC and TC types. Each demonstration is designed to be maximally representative and informative by meeting certain minimum requirements. Each host system has at least

- 700 customer meter points.
- 50 distribution control and monitoring points.
- Two or more substations.

- Three or more feeders.
- Underground and overhead feeders.
- Urban, suburban, and rural feeders.
- Industrial, commercial, and residential customers.

Each of the utility systems includes a central customer transmitter/receiver at each meter, and a transmitter/receiver at each distribution control point, also auxiliary equipment for the PLC systems.

This is an extensive project which should provide significant results starting in mid-1979, and will be completed by September 1980. The project exemplifies the cooperation between EPRI and DOE and shows EPRI's commitment and involvement in DAC development.

6.3 ELECTRIC UTILITY SYSTEM CONTROL IN THE YEAR 2000

Dr. Fred C. Schweppe
 Professor, Electric Power System Laboratory
 Massachusetts Institute of Technology

Abstract from "Homeostatic Utility Control"*

Homeostatic utility control is defined similarly to "homeostasis" in relation to biological functions in humans. It denotes a type of utility system control wherein the generation/supply is in equilibrium with the demand/load, by means of advance control and communication devices. Classical supply-demand interaction has been primarily controlled by the user. The users have total free will regarding their power use, and the utility simply does what is necessary to reliably meet the power demands of their customers. At the other end of the spectrum, total utility control over customer loads could be an effective mechanism for maximizing the utility's efficiency but would be undesirable to the customer. Homeostatic control can provide the utility predictable and smooth load curves to facilitate careful capital planning and maximize generation efficiency. It can also satisfy the customers' desires for free will autonomy over their power use by the institution of two new elements, the Energy Market Place and the Frequency Adaptive Power Energy Rescheduler (FAPER).

*This Abstract refers to a paper by Fred Schweppe, Richard Tabors, and James Kirtley of MIT entitled Homeostatic Utility Control, and accurately summarizes Dr. Schweppe's comments at the DAC Working Group meeting.

The Energy Market Place is established by means of having two-way communication from the utility to the load points, which permits the utility to regularly compute an accurate "spot price," perhaps every 5 minutes or so, which accounts for the actual cost of producing power at that point in time. This spot price would take into account the total load, generating efficiencies, fuel costs, losses, weather peculiarities affecting the utility system, etc., and be calculated by a complex set of equations approved by the Public Utility Commission. The FAPER would assist in controlling various components of a single customer's load according to the rise and fall in the line frequency, acting somewhat like a governor. The Energy Market Place would work by means of allowing the customer to "automatically" balance the load. Customers could choose to install a unit at their load point which would be sophisticated enough to predict price patterns and plan a maximally cost effective load curve. The FAPER could also be designed to intelligently consider certain price and load patterns.

The control and communication technology required for the user's meter and price announcing unit, the two-way communication system, and the utility generation control and price computing devices is not trivial, but neither is it beyond today's capability. The most significant problems to be overcome relate to regulation, customer acceptance, and utility acceptance of such an entirely new way of doing business in the utility industry. Nevertheless, the advantages should be examined as they warrant solving these problems.

By smoothing out load requirements predictable, homeostatic utility control will permit less capital outlay due to higher running efficiencies and smoother operation of generating units having less system fluctuation. Downstream minor variations are handled at the site by the user's economic choices related to the "spot price" of electricity and the FAPER's activity. This control scenario also permits free will use by the customer in regard to the timing and amount of his power consumption. In addition, those customers desiring a higher level of predictability in their power price and availability may as always, negotiate a long term guaranteed contract. Homeostatic utility control is technically possible and provides benefits which warrant overcoming the institutional barriers likely to be encountered in its implementation.

6.4 INTRODUCTION OF TECHNICAL MOTIVATIONS

Chairmen's Panel:

James Hunter, San Diego Gas and Electric -
Load Management

Robert Ferber, JPL - Unconventional Energy
Resources

Harold Kitching, New England Power Service -
Distribution System Management

William Prince, Baltimore Gas and Electric -
Emergency State Control

NOTE

Before the start of the first round of working sessions, the chairmen of the session discussions on the four Technical Motivations were requested to introduce their topic and their working session. The Technical Motivations are Load Management (LM), Unconventional Energy Resources (UER), Distribution System Management (DSM), and Emergency State Control (ESC). Their introductory remarks are summarized in this section.

6.4.1 Load Management

James Hunter, San Diego Gas and Electric

The background definitions and material on Load Management (DAC Working Group Information Booklet) provided a good deal of valuable information. Without spending much time on this detailed information, already provided, the LM discussion will focus in on a number of more basic issues:

- Why manage loads?
- What are the objectives for LM?
- How does the regulatory environment influence decision-making regarding LM?
- Will the American public allow their loads to be managed?
- What are the societal issues facing LM?

Delving into these broad questions should elucidate more about the basic purpose, interest, and nature of LM.

Also, Load Management means many things to many people, so the session will attempt to further tighten down the definition of the term. We must understand what it is we are all talking about. LM is an important new step for the utility industry because, in essence, LM means that we are now going to consider offering different types of service to the customer: Cadillac, Chevy or Ford. We must carefully weigh the requirements and ramifications of this new step.

6.4.2 Unconventional Energy Resources

Dr. Robert Ferber, Jet Propulsion Laboratory

NOTE

The UER Working Session was combined with the LM Working Session. Since James Hunter had introduced the working session quite thoroughly, Dr. Ferber chose to orient the DAC Working Group participants to UERs as new technology entering the electric utilities' domain. Dr. Ferber's major points on UER are given here, especially those relative to LM. However, most of his comments specific to solar energy were given in his dinner presentation, in Section 6.5 of this Proceedings.

Unconventional Energy Resources are quite important in the development of DAC technology because UERs will be making a significant entrance into the electric utility generation mix in the next 10 to 15 years. UERs will most frequently fit into the category of dispersed storage and generation. Such technologies include battery storage, compressed air storage, fuel cells, etc. These technologies all point towards increasing energy efficiencies, which is also a specific, stated goal of the DOE program for DAC (see Section 5.1). DOE is also encouraging maximum penetration of renewable domestic energy resources which points towards UER technologies such as solar, wind, and fuel cells. Therefore, UER implementation is quite supportive of DAC development. The management of these dispersed sources, as they become a significant portion of a given system's generating capacity, will be a new and difficult task. Properly designed DAC systems can be particularly helpful in accomplishing the task of controlling these units. Any recommendations for how the UER/utility system interface should function relative to control, safety, rate structures, etc., will be a significant contribution from this DAC Working Group.

6.4.3 Distribution System Management

Harold Kitching, New England Power Service Company

The four Technical Motivations can be seen as analogous to a stand of trees. We see the towering pines of Load Management, the stalwart oaks of Emergency State Control, and the colorful maples of Unconventional Energy Resources. A closer look also reveals the white birches, if you will, of improved service quality and operating efficiency. There they are, but where in this analogy is a symbol of Distribution System Management? It is missing, but some might suggest that we have been standing just a little too close to the trees to see the forest, for indeed it is the forest itself that is the symbol of Distribution System Management.

Clearly all of the motivations that we are going to consider lead to changes which impact the utility distribution system. As Distribution System Management encompasses all of the motivations, it may provide a very valid viewpoint for the purpose of examining the economic considerations of Distribution Automation and Control. It is this total economic picture that is required. In a narrow view one might screen out those portions of the other motivations which are indeed closely related to supply considerations. Would distribution system management still be a significant motivation for Distribution Automation and Control? If we were to respond to this question in the context of today's systems, performance, and needs, the answer might be obvious, but what about tomorrow's needs, with tomorrow's loads, and the distribution systems that will supply them? Distribution systems continue to benefit from the economy of scale as the voltages move from 15 to 24 to the 34-1/2 kV classes. Can we reasonably expect to continue to enjoy these economies of scale and operate our systems in the same manner as we have at the lower voltages?

There are opportunities to operate tomorrow's systems, or even today's systems efficiently and economically by using Distribution Automation and Control techniques. Well, hopefully our discussions on the subject and the questions that follow will clear out some of the underbrush from our forest, so that the key issues will be more visible. Then we can get down to chopping some wood.

6.4.4 Emergency State Control

William Prince, Baltimore Gas and Electric

The first thing to examine is the definition of Emergency State Control. My perspective comes largely from a bulk power system point of view, being the Chief System Operator for Baltimore Gas and Electric. Now, with the advent of DAC systems, we are to look at applications of ESC down to the level of the distribution system. ESC currently exists, in various forms, at the bulk level where certain emergencies can be dealt with through a shift in generation or perhaps even closing or opening a line. However, if these solutions fail, then load shedding of one form or another is used on the distribution system. This can take the form of voltage reduction, rotating load-shedding or rapid load dump. Supervisory Control and Data Acquisition (SCADA) systems, energy control centers, etc., are common. A major difficulty in control within the distribution system is selectivity, due to the size of the system and thousands of multiples of various types of equipment units. DAC systems could be quite valuable if they significantly increase the selectivity of control systems over current systems.

Precisely what ESC is must be examined, as it can mean many things. An emergency state can arise from cars knocking down poles, people digging into cables, squirrels getting into line equipment or most traumatically, a storm. Emergency State Control methodology depends on the source and type of the emergency. In fact, in the

distribution system, there currently is no ESC. Response to failures in the distribution system is not really ESC, it is an attempt to minimize restoration time. The distribution system is in either a normal or restorative state.

The reliability of today's distribution systems is very high. Many of the restoration requirements in the distribution system can only be met by sending a crew into the field to repair the downed line, etc. Because of all these factors, DAC systems must demonstrate a significant improvement in fault location and/or fault restoration before they can be justified on the basis of ESC. The real issue is the economic cost effectiveness in light of what service the public is going to receive and what they are willing to pay for it. We must discuss and determine what genuinely valuable ESC related functions DAC technology can provide at a reasonable cost.

6.5 SOLAR ENERGY AS AN UNCONVENTIONAL ENERGY RESOURCE

Dr. Robert Ferber
Requirements Definition Task Manager, SPSA Program
Jet Propulsion Laboratory

NOTE

Dr. Ferber reviewed the field of solar energy research. His major comments are synopsized here.

Solar energy takes many forms. It can be tapped through innovative architectural design, it can be gathered by collectors for heating and cooling, it can be concentrated for intermediate and high temperature applications, it can be converted directly into electricity, and can also be utilized indirectly in the form of wind, falling water, various forms of biomass including forest products, and ocean temperature gradients.

The amount of solar energy that reaches the earth's surface in 2 weeks is equivalent to the energy in all known fossil fuel reserves. Nevertheless, use of this abundant energy source at present is very modest. In the U.S., indirect solar sources (hydropower, combustion of biomass) account for only 5 percent of the national energy supply. Worldwide, the figure is about 15 to 20 percent.

Efforts are beginning, however, to develop the broad range of solar applications. Some technologies, such as passive solar design, combustion of biomass, and active solar hot water and space heating, are economic in many regions now. Others, such as biomass conversion to liquid and gaseous fuels, and solar technologies for generating electricity, require further research. The solar technologies which can be used for electric power generation are briefly summarized here.

6.5.1 Solar Thermal Power Systems

Description

Solar thermal power systems involve direct conversion of solar energy to thermal energy, and subsequent conversion of the thermal energy to mechanical energy in a heat engine. The mechanical output of the engine can be used to generate electricity.

Present solar thermal power systems are of two types: those using a central receiver system and those using a distributed receiver system. Both systems collect and concentrate the direct (rather than the diffuse) component of sunlight and utilize it to heat working fluids such as high pressure water, steam, hydrocarbon oils, molten salts, and liquid metals.

Markets

The solar thermal power program is aimed at three major applications:

- (1) Large-scale centralized electric power generation
- (2) Smaller-scale dispersed applications for electric power generation
- (3) Smaller-scale on-site total energy applications involving both electricity and heat production.

6.5.2 Photovoltaics

Description

Photovoltaic cells convert sunlight directly into electricity through the use of semiconductor materials such as silicon, cadmium sulfide, and gallium arsenide. Photovoltaic cells are grouped into arrays which are combined in a total subsystem, including power processing, control, and interface equipment.

The current DOE program goals are to reduce the cost of solar arrays to \$2/Wp of electric capacity by 1982, \$0.50/Wp by 1986, and \$0.10 to \$0.30/Wp by 1990.

Markets

In addition to developing the U.S. market, there is presently a much larger market in the less developed countries for power in remote villages.

With subsequent reduction in array costs, photovoltaic systems will be attractive for dispersed power generation and are potentially suitable for peak and intermediate electric power generation.

6.5.3 Wind Energy Systems

Description

Wind energy has long been used for water pumping and generating electricity. Modern wind machines perform these functions in on-site applications and may also generate electricity for distribution through a utility grid.

The energy output of a wind turbine is principally a function of wind velocity at the site and rotor diameter of the machine.

Markets

DOE is pursuing the development and demonstration of small machines (2 to 40 kWe) which could be utilized by an individual rural home, farm, or ranch and intermediate sized machines (100 to 200 kWe) for use by towns and rural electric cooperatives.

The wind resource base is large: 2 to 5 quads of electrical power, according to recent estimates.

6.5.4 Ocean Systems

Description

Renewable ocean energy resources take several forms and can be used to generate substantial quantities of electricity and to produce energy-intensive products. Ocean energy system concepts under study and development include Ocean Thermal Energy Conversion (OTEC), salinity gradients, ocean currents, and ocean waves. In the near term, OTEC appears to be the most promising ocean energy option and is receiving the greatest emphasis.

An OTEC system would use ocean temperature differences between warm surface water and cold water from the depths to produce baseload electricity. Typical systems for achieving this conversion may use ammonia as a working fluid, which is evaporated by the warm water, drives a turbogenerator, and is then condensed by the cold water. OTEC energy would be utilized as electricity conveyed to shore by submarine cable, and in the production of energy-intensive products (such as ammonia, aluminum, hydrogen, chlorine) on or near the OTEC platform.

Markets

OTEC-generated baseload electricity would be of most interest to utilities in the southern United States and to those serving Hawaii and Puerto Rico. Also, energy intensive chemicals might be produced on OTEC plantships and delivered to port.

SECTION 7

WORKING SESSIONS

The most valuable of the DAC Working Group's activities took place in nine Working Sessions. In these, the four Technical Motivations and six Areas of Issues related to DAC development were discussed. As a basis for the discussions, all of the participants were provided with the DAC Working Group Information Booklet, which identified and discussed the Technical Motivations and Areas of Issues. These Working Sessions were conducted by chairmen chosen from within the utility community. Each group met for two to three hours to discuss the definition of and pertinent issues related to the particular area of DAC development with which the session was concerned. The results of these discussions are recorded in Sections 7.1 through 7.9.

7.1 LOAD MANAGEMENT AND UNCONVENTIONAL ENERGY RESOURCES COMBINED WORKING SESSION

Co-Chairmen:

James Hunter (Load Management)
Manager, Marketing Programs
San Diego Gas and Electric Company

Dr. Robert R. Ferber (Unconventional Energy Resources)
Requirements Definition Task Manager, SPSA Program
Jet Propulsion Laboratory

NOTE

The Load Management (LM) and Unconventional Energy Resources (UER) Technical Motivation Working Sessions were combined in order to have adequate session attendance in both areas for a healthy interactive discussion. In response to the primary interest of the majority of the session participants, the discussion focused heavily on issues related to Load Management.

7.1.1 Revised Definition Statement - Load Management

The group immediately focused on examining the definition of Load Management presented in Fact Sheet 1 of the DAC Working Group Information Booklet (see Appendix D). The discussion revolved primarily around the issue of reserve requirements being affected by the advent of LM. The group developed the following revised definition (the

quoted portions of the definition are taken unchanged from the definition in Fact Sheet 1 in the Information Booklet):

From the DOE Program Plan (DOE/ET 0004):

"Load Management is the systems concept of altering the real or apparent pattern of electricity use in order to

1. improve system efficiency
2. shift fuel dependency from limited to more abundant energy resources"
3. reduce reserve requirements while maintaining reliable service to essential loads.

The group recognized that adequate time was not available to discuss the impact of load management on spinning reserve, 10-minute or other reserve criteria. Therefore, the above definition needs further clarification in these areas.

7.1.2 Definition Statement - Unconventional Energy Resources

The definition of Unconventional Energy Resources in Fact Sheet 4 of the Information Booklet was not challenged. Portions of that definition are re-stated here for reference purposes.

"Unconventional Energy Resources (UER) are energy storage or generating systems using renewable resources or devices ... to complement conventional power generation (fossil and nuclear steam turbine, hydro, gas turbine) methods. A common characteristic of these sources is that they are small in unit size compared to traditional central station generation...

"These resources will generally be dispersed throughout the distribution system, with sites selected due to availability of waste heat, need for waste heat, presence of favorable wind conditions, access to roof or other unused space, etc. Thus, the definition of UER for purposes of DAC discussions implies remote control and remote monitoring of status and capacity of such units."

7.1.3 Major Statements

The group formulated the following major statements in the Load Management and Unconventional Energy Resources areas:

(1) Load Management:

- (a) Regulatory requirements are not a necessary precursor to the implementation of LM. Utilities are going ahead with LM development without regulatory motivation, and regulation would probably not significantly alter current efforts.
- (b) More work should be done in preparing customers for the LM concept and its effects on service. This type of improved public awareness effort does not require results from detailed engineering studies.
- (c) Customers probably are willing to entertain the idea of alternate forms of service if they are adequately prepared for it and educated as to the need and ramifications.
- (d) Current development efforts are primarily being directed towards lowering daily peak demand levels. Additional efforts must be started to address potential LM effects on monthly, seasonal, and annual load demand curves.
- (e) The question of whether the utility customer is willing to accept reductions in quality of service, selective load control, or other changes in historical level of service must be answered.

(2) Unconventional Energy Resources:

- (a) Bidirectional power flow from dispersed UER units will be acceptable to most utilities. However, this acceptance must be preceded by establishment of special rate structures, adequate safety provisions, etc. (Note: This issue was dealt with more thoroughly in the New Source Integration Working Session, Section 7.9 of this volume.)
- (b) Solar thermal space and water heating or cooling will have the most significant near-term impact of all UER on the displacement of energy from conventional sources.

- (c) Significant effects on the operation of utility distribution systems may come from the near-term application of wind turbine generators and, eventually, from solar, or other types of dispersed generation and storage, requiring new control means.

7.1.4 Discussion

Discussion was lively and covered a breadth of topics related to both UER and LM. The group did not come to many firm conclusions; instead, they formulated statements of a number of issues and some tentative recommendations for the management of future DAC development in these areas.

Following the opening remarks regarding the definition of Load Management, the group discussed reserve briefly. By definition, LM appeared to be oriented towards changes in energy use patterns, which in turn affect reserve requirements. With the advent of LM, however, against what baseline will reserve needs be measured and how does it change for spinning versus installed reserves? The group was unsure what would happen to reliability as a result of changing reserves due to LM. Does it go up or down, depending on the load? LM may in fact reduce reliability overall; nevertheless, LM effects on reliability should be identified and communicated throughout the industry in order to dispel this confusion.

The group then discussed the problem areas facing LM and UER to determine if the development of these technologies is presently "on target." It was realized initially that better methods of assessment and better data are needed to be able to rationally critique today's programs. The discussion proceeded to range across all aspects of the topic. Some of the comments made were

- (1) LM techniques will vary for each utility. What is appropriate for different applications?
- (2) Trade-offs in LM between the bulk and distribution systems must be addressed.
- (3) How can LM efforts of numerous utilities in a common power pool be successfully coordinated?
- (4) As LM creates or leads to varying rate structures, will special provisions have to be developed to deter primarily purchasing utilities from abusing the "rate game"? If so, what?
- (5) As an initial program, San Diego Gas and Electric currently offers load information to large industrial customers for the purpose of voluntary LM to reduce customer costs.

Discussion then moved to the importance of communication systems in facilitating the control needed for LM and especially the inadequacy of current frequency spectrum allocations. Utilization of dispersed storage and generation (DSG) units will depend on DAC controls; but such units do not appear to have potential for significant near-term penetration of the distribution system.

The group began a discussion of the approaches to LM and UER and the studies being performed. They indicated their belief that, since LM, UER, and DSG all have notable, long-term ramifications, DOE should be gathering more input from the utility community.

The management of LM systems development is a difficult "chicken-egg" problem. Specific hardware studies must be performed to show technical feasibility. Also, applications and implementation impact studies must be done to predict effects of installing these as yet nonexistent advanced DAC systems. Many DAC related studies are being done in parallel by different organizations.

The group generally seemed to feel that neither DAC technology nor its effects on operations are clearly understood, and that more efforts in the total DAC area are needed to clarify these interactions.

The group considered the effects of LM on changing load shapes. Water heater cycling was discussed and seen as advantageous, but hardly a panacea. The difference between load cycling, load shifting, and load elimination must be recognized to avoid overinterpreting the potential benefits of certain aspects of LM. It was realized that efforts must be undertaken to study monthly, seasonal, and annual load curves as well as the management of daily peaks. Finally, the group considered the acceptability of various aspects of LM to customers and the motivation for utilities' interest in LM. It was concluded that most utilities had economics and performance as motivations, not regulatory compliance. Customers may be expected to accept new types of service; however, much must be done to educate and prepare the public for these changes.

The advent of two-way power flow from dispersed UERs was briefly discussed. There was general agreement that dispersed UERs are coming and in the distant future may represent a significant percentage of generation, but safety, operation, rates, and control issues must be dealt with first.

7.2 DISTRIBUTION SYSTEM MANAGEMENT WORKING SESSION

Chairman: Harold Kitching
Distribution Development Engineer, TWACS Program Manager
New England Power Service Company

7.2.1 Revised Definition Statement - Distribution System Management

The Distribution System Management (DSM) Working Session opened with a discussion of the definition of DSM. There was some confusion regarding whether DSM was a subset of DAC or vice versa. The definition in Fact Sheet 2 of the DAC Working Group Information Booklet (see Appendix D) was felt to be too lengthy and perhaps unclear. The group produced the following revised definition statement:

Distribution System Management is defined as the control and direction of the planning, design, construction, operation, and maintenance of the distribution system to provide safe, economical, high quality service to the customer.

7.2.2 Major Statements

The chairman led the discussion in three major topical areas related to DSM: applications, economics, and technology. A number of major points or issues were concluded with near unanimity of the session in each area.

Applications

The utility companies should be responsible for defining what needs to be done in the area of system applications, as they will eventually be responsible for the system's performance.

When and how are we to implement DAC systems for advanced DSM and at what level of complexity and function within the distribution system?

What functions will dominate, determining the control hierarchy?

Economics

Nearly all projects must be justified on the basis of economics, with a proper understanding of both near and long term cost benefits from the expenditure.

Economic justification is occasionally overruled when a project is done in response to absolute system functional needs or new government regulations. These motivations can force the implementation of a project, regardless of economics.

Technology

Hardware performance characteristics must be specified for the system function and the system environment required to achieve the designed function.

7.2.3 Discussion

The group, after the definition of DSM had been revised, identified DSM-related projects in which the session members were involved.* The discussion then proceeded, organized around the three themes of applications, economics, and technology.

Applications

DSM applications issues were divided into two subsets: identification and implementation. Using the lists of Key Issues and Uncertainties from the Information Booklet (see Appendix D), regrouped under the three themes of the discussion by the chairman, the group established a number of points and new issues:

- (1) DSM functions should be separated into distinct groupings which relate to separate DAC subsystems or component groupings to facilitate design.
- (2) DSM will not have a significant effect on distribution voltage levels.
- (3) Control hierarchies for DSM's interfaces with ESC, LM, and DSG must be understood, despite some confusion introduced by the fact that DSM, by definition, includes ESC, LM, and DSG.
- (4) The availability of controllable loads will have some effects on the development of the distribution system. Exactly what types of loads will be available for control by utilities may be determined by consumers and regulatory or other government agencies.

It was realized that there are numerous issues and potential barriers and opportunities facing the implementation of DSM applications; however, the group did not have time to discuss these issues.

*Appendix B lists all of the Working Group participants and indicates their various activities in DAC development.

Economics

The fact most obvious to the group regarding the economics of DAC systems was that cost effectiveness must be shown for all voluntary projects, and much of the data and information necessary to demonstrate the cost/benefit effects is either not yet available or not reliable enough for making investment decisions. It was noted that DAC systems do lend themselves to good cash flows since they can be implemented very gradually, avoiding massive front-end capitalization. It was felt that establishment of some standardized, quantitative methodology of analyzing DSM/DAC systems would be very valuable to the industry. DSM system development presents an economic problem: How can the risk and high cost of development to manufacturers be reconciled with the unproven value of the systems to utilities? Some members felt that the government would have to assist in this area, but the group as a whole was not sure how best to approach the problem. This problem may change significantly if the trend to reduced costs over the last five years in the electronics industry continues and carries over into DAC equipment costs.

Technology

The group felt that each utility would eventually have to design or specify its own technical systems and requirements; nevertheless, general systems having parametric flexibility could be defined as baselines for evaluation purposes. The effect of government actions on potential technical advances was considered to be significant. Generalized solutions could become of great value to the industry by facilitating broad penetration. However, government regulation could severely impact viability of such technology, either pro or con, with no real regard for economic or engineering feasibility. The government's role should be examined and defined.

7.3 PREVENTIVE, EMERGENCY, AND RESTORATIVE STATE CONTROL WORKING SESSION

Chairman: W. R. Prince
Chief System Operator
Baltimore Gas and Electric Company

7.3.1 Revised Definition Statement - Preventive, Emergency, and Restorative State Control

The participants in the session broadened the definition of the session's topic, presented in Fact Sheet 3 of the DAC Working Group Information Booklet (see Appendix D), to include preventive, emergency state, and restorative state control. The broadened definition provides a means of focusing on differences between bulk power and distribution system needs. For example, from the bulk power system point of view, "emergencies" are best controlled by prevention

and from the distribution system point of view, "emergencies" are appropriately dealt with by restoration of service.

Preventive, Emergency, and Restorative State Control (PERSC) refers to the ability of a DAC system to remotely and/or automatically provide (1) preemptive action in anticipation of an emergency state, (2) emergency state detection, and (3) corrective and restorative control.

NOTE

The remainder of the definition statement is quoted directly from the DAC Working Group Information Booklet, but with "PERSC" substituted for "ESC".

Present Supervisory Control Systems do not provide a method of accomplishing PERSC at the distribution level. Therefore, discussion needs to consider DAC providing control:

- (1) To the depth, or to the level of of discrete elements contemplated for further systems.
- (2) For all aspects of PERSC, e.g., anticipation of certain kinds of emergency states.
- (3) With dispersed generation and storage generally which will be connected to the distribution system.

Further, the full application of PERSC will require methods for response to two kinds of emergency conditions:

- (1) Loss of, or imminent loss of, bulk supply facilities (load shedding, start-up or increase in output from dispersed storage and generation).
- (2) Loss of, or imminent loss of, portions of the distribution system...

7.3.2 Major Statements

- (1) The title of the session was much too restrictive. (There was general agreement on this.)
- (2) "Emergency State Control" can be discussed in the context of the bulk power system; however, "Emergency State Control" does not relate to restoration in the distribution system (see revised definition statement).
- (3) DAC systems capabilities for actions related to emergency control will differ from those capabilities required for actions related to restorative control.
- (4) Utilization of DAC equipment and PERSC methods will provide more time for utility system operators to make decisions under "emergency" situations.
- (5) When load shedding, under "emergency" conditions, societal priorities can be recognized by DAC systems' selectivity.
- (6) The cost effective analysis for PERSC, relative to other ways of responding to supply deficiencies, needs to focus on DAC equipment applied to specific systems.
- (7) Control of loads by DAC systems may result in spinning reserve credits.
- (8) Since customers may ultimately determine standards for reliability, the question may be, "How much additional cost will the customer tolerate for PERSC implementation?"
- (9) All communication links can be expected to fail at one time or another; therefore, is DAC equipment more or less reliable than the distribution system itself?
- (10) When dispersed generation is connected to the utility grid, the owner of the dispersed system should pay for any specially required DAC equipment.
- (11) Predictive control will not be implemented until far in the future.
- (12) In the bulk system, emergency control can best be accomplished through selective load shedding via DAC in the distribution systems.
- (13) Currently there are no national standards for reliability. (There appeared to be general agreement that such standards are not necessary.)

7.3.3 Discussion

At the beginning of the session the participants agreed that the title of the session, Emergency State Control, was too restrictive. The title was broadened and changed to Preventive, Emergency, and Restorative State Control. The chairman led the group in a discussion which centered around three topics:

- (1) Bulk system tie-ins.
- (2) Distribution system.
- (3) Distribution system management.

The chairman focused discussion by referring to the "Key Issues and Uncertainties" presented in the DAC Working Group Information Booklet. The distinction between emergencies in the bulk power system and in the distribution system was illustrated by the following analogy: An emergency, from the bulk power point of view, exists if there is a hatchet over your head, and from the distribution system point of view, if your arm is cut off and laying on the table. Clearly, distinctly different DAC equipment capabilities are necessary to meet bulk system and distribution system needs. A participant commented that manufacturers cannot produce DAC equipment economically for today's utility systems. The discussion moved to issues involving load shedding for meeting emergencies in the bulk system. When dealing with load shedding hierarchies, the group acknowledged the significance of social issues.

The participants in the session agreed that people determine the required level of system reliability. They also agreed that the acceptability of outages depends on many parameters. Another participant emphasized the absence of national reliability standards, and it was concluded by the group that such standards were not necessary. The reliability of DAC equipment was discussed.

The participants acknowledged that DAC creates massive amounts of data. However, there was disagreement about the usefulness of the data. Some of the participants felt that computer data processing will increase the usefulness of the data in planning and decision-making. The participants discussed the effects of dispersed generation in load management.

The PERSC session was extremely active. As the session concluded, individual participants made the following comments:

- (1) The interaction of distributed system generation and utility operations is "tricky."
- (2) PERSC will not produce a large impact on distribution system management.
- (3) Requirements for reliability will be determined company by company.

- (4) Predictive control in the distribution systems is far in the future.
- (5) The probability of massive power failures can be prevented by using selective load shedding methods

7.4

DAC FUNCTIONAL REQUIREMENTS WORKING SESSION

Chairman: Kenneth W. Klein
Technical Assistant to the Director
Division of Electric Energy Systems
United States Department of Energy

NOTE

In a dinner presentation on the second evening of the workshop Mr. Klein described the result of the Working Session. The highlights of his presentation, as related to DAC Functional Requirements, are given here.

Defining "functional requirements" for any type of advanced engineered system is a difficult task. This is particularly true for systems involving DAC technology, which is still in the early stages of development. To provide a basis for the Working Session, the participants were provided with the following background/definition statement in Fact Sheet 9 of the DAC Working Group Information Booklet (see Appendix D).

7.4.1 Definition Statement - DAC Functional Requirements

The functional requirements for future DAC systems will be determined by consideration of

- (1) The needs for systems satisfying the performance needs for each Technical Motivation.
- (2) The present and future configurations of power and control systems without DAC systems.
- (3) The present and future needs for information as mandated by forces outside the utility...

The functional requirements may be thought of, in very general terms, as specific objectives such as improving efficiency, reducing peaks, increasing reliability, etc. However, this way of expressing functional requirements is insufficient for purposes of identifying DAC system specifications.

Also, the general functional requirements can be identified by describing a specific effect desired, such as isolation of faults, synchronizing of dispersed generation, monitoring of transformer and line loadings, voltage regulation within limits which can be varied remotely, load control, automatic meter reading, etc. Again, this kind of description is too general for purposes of specifying DAC systems.

Functional requirements must ultimately be defined as t-

- (1) Purpose of type of function (status, command, telemetry).
- (2) Relationship to Technical Motivation.
- (3) Relative importance to power system operation.
- (4) Frequency of application (how often will function be used?).
- (5) Response time requirement (how quickly must function be accessed?).
- (6) Reliability (level of assurance that command will be received and executed).

7.4.2 Case System Exercise

To properly understand the results of this session, the manner in which it was conducted must be understood, as it was different from all of the other discussions. The chairman had developed two distribution case examples for the group to inspect, and a worksheet for each.

Case I

Case I was a simple radial distribution circuit served via a two-bank substation arrangement fed by two 132 kV subtransmission lines. The subtransmission and substation devices shown on the Case I line drawing (Figure 7-1) were said to be specified at the N-1 rating. This example was to be used as a "typical" present day system. The session participants were then asked to sketch on the drawing (if appropriate) and write on the worksheet all of the devices or functions which the individual thought should be automated or controlled, and to describe the function. This list was to be formed as almost a DAC

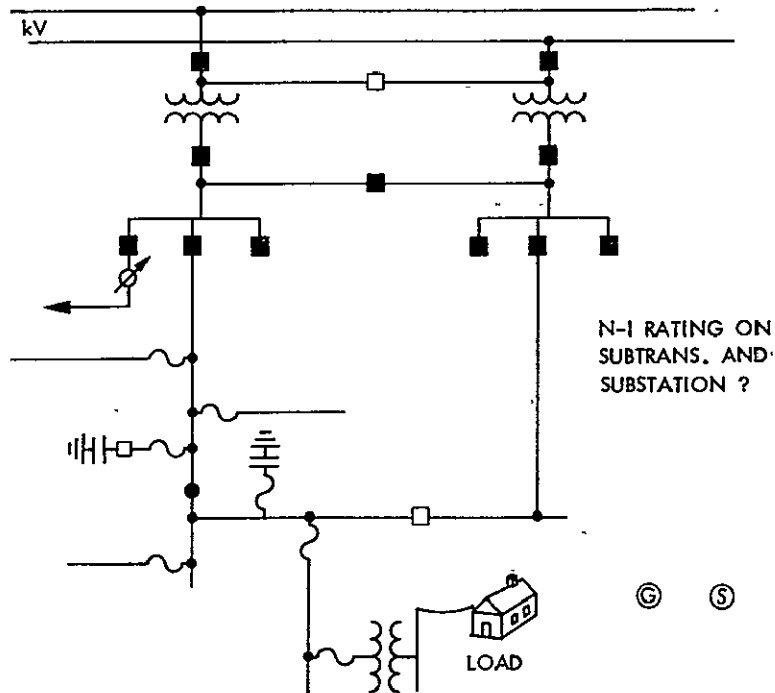

Figure 7-1. Case I Distribution Circuit

"wish list" with little or no thought of economics, but only system function and automation. Participants were also requested to note the required level of unit reliability. Upon completion of this study of "typical" Case I, Case II was revealed.

Case II

Case II (see Figure 7-2) was essentially the same as Case I except that

- (1) The substation feeder ties were eliminated to create essentially two separate substations from the two feeder banks.
- (2) Dispersed storage and generation were included (if desired).
- (3) Units had only normal capacity rating, not N-1 rating.

Using Case I as a basis, the group was then requested to develop a DAC system for Case II which would insure the same level of reliability in the distribution system, without substation feeder ties. Again, the

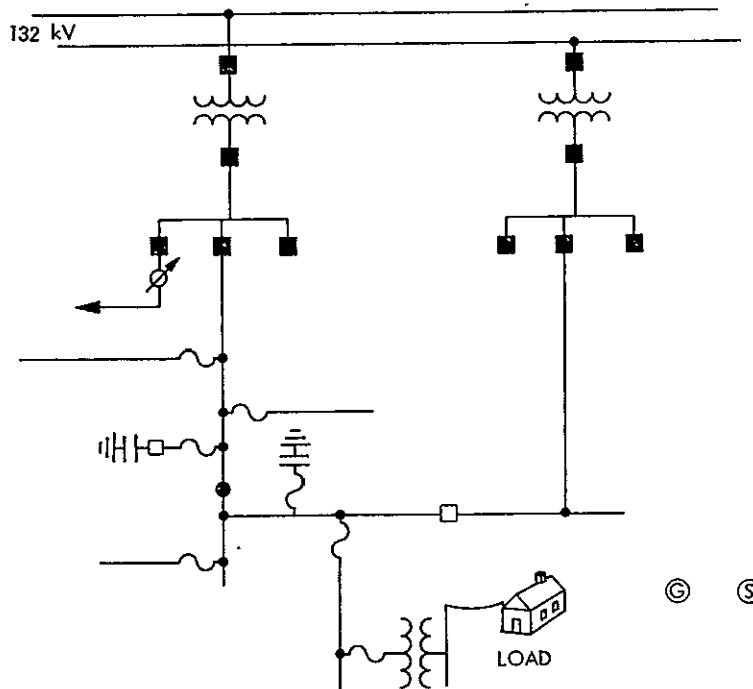

Figure 7-2. Case II Distribution Circuit

device, function, and unit reliabilities were to be described. Reliability was to be listed from 1 to 10 as follows:

- (1) No reliability requirements (function or data is desirable but nonessential).
- (5) Typical reliability requirements (need to keep entire system outage/reliability rate at present day levels. - "status quo").
- (10) 100% reliability requirements (essential function requiring near-perfect devices or adequate unit redundancy).

The exercise for Case II was to converge on general reliability requirements. The results of this exercise were quickly tabulated during the session so the participants could discuss their ideas. The devices/functions were categorized according to their priority to the system (for Case II), and this ranking approximately paralleled the device reliability requirements. (It should be remembered that these priorities were determined without regard to cost-effectiveness. This exercise was performed to inspect functional requirements in order to assess where the greatest efforts must go to develop reliable, low cost technology.

7.4.3 Summary of Results

Device/Function	Reliability Requirements (from 1 = lowest to 10 = highest)	Priority Rating (A = high, B = moderate, C = low)
Communication System	8-10+	A
Load Management		
Normal	3-5	A
Emergency	3-7	A
Control of Fault Clearing Devices		
Line	3-10	A
Substation	5-10	A
Fault Indicators on Primary Circuits	5-10	A
Automated Protective Schemes	7-10	A
Periodic Check on All Devices	1-3	A
Control of DSG	3-7	B
Time-of-Day Metering	3-10	B
Station and Field Tap Changer Control	3-7	B
Metering		
Substation	3-5	B
Line	3-5	B
Spur/Customer/etc.	3-5	B
Status Interrogation		
Fuses	1	C
Others	1	C
Customer Outage Status	1-3	C
Customer Load Studies	1	C
Transformer Load Management	3-5	C
Equipment Security	1	C

Clearly these results are not comprehensive: They represent only 2½ hours of effort on two hypothetical case studies and are highly subjective. Nevertheless, they do indicate a general outline of what functions are of importance. The group intentionally made no attempt to specify equipment functions in detail (cycle speed, lifetimes, size, cost, etc.) but confined themselves to the task of general functional descriptions. When this information was presented to a plenary session of the Working Group, there was little disagreement with the conclusions. This would indicate that the results give a fair first impression of what direction the utilities would like to see DAC development take. Most noticeably, nearly all participants agreed that reliability and high performance for the communications system was the top DAC priority.

7.4.4 Major Key Issues

The group discussion touched on many points. These can be reduced to eight major issues:

Economics

Essentially, any DAC system or device must be justifiable in terms of cost. Simply stated, the added control must be able to offset the capital requirement. Therefore, design efforts must emphasize the minimization of costs.

Reliability

The group realized that reliability is a key element in hardware design and implementation, and reliability needs must be carefully scrutinized. The group stated that not all components need the same level of reliability. For example, the reliability needed in the communication system may vary according to the system's function, what is being communicated, and to whom or what and in which direction (outbound versus inbound) the data is being transmitted.

Unknown System Effects

The group asked what the real effects and advantages of new system elements will be. For instance, many things are unknown about the factors involved in the implementation of dispersed storage and generation, such as control, safety, reliability, etc. Such factors must be analyzed in the design and development process.

Protective Systems

What will be the integrity of protection devices under actual fault conditions, or when circuits are reconfigured? The designs of protection devices must be able to somehow include the capability to respond to unusual or even unforeseeable conditions.

Local vs. Central Control

What is the hierarchy? What functions should be controlled locally and centrally, and how will this affect system design?

Current System Reliability

The reliability of today's systems and components should be defined. There is a lack of firm data on reliability, and this lack prevents the accurate determination of what improved levels are needed for DAC systems. Unless present-day baseline data are clearly established, future system performance cannot be properly analyzed or compared with previous systems. The group acknowledged that determining reliability in distribution systems is particularly difficult, since such systems contain many pieces of equipment and each must be analyzed separately.

Existing Company Policies

Each company's policies determine capital structuring and investment, control hierarchies and procedures, design criteria, equipment selection, redundancy and reliability requirements, automation levels, etc. Changes in policies will be occurring, and policy needs related to DAC should be made known and considered. These policy changes alone could significantly improve or reduce the cost effectiveness of advanced control and automation.

Higher Voltages and Reliability

Future distribution system voltages may go as high as 69 kV. DAC systems will be called upon to increase the safety and reliability of these types of distribution systems and must be designed to accommodate this requirement.

7.4.5 General

Time constraints and the wide scope of the task of defining all of the needed DAC functions for a future distribution system precluded the group's preparation of a definitive, detailed statement of functional requirements. However, the group did identify the key issues as shown above. Much effort must go into the development of

the communication system, and the reliability of all components should be carefully specified. In every case, the design will ultimately be given the test of economics.

7.5 ECONOMIC AND INSTITUTIONAL ISSUES WORKING SESSION

Chairman: Glen Lokken
Superintendent, Special Studies
Wisconsin Electric Power Company

It was the chairman's feeling that the subject of economic and institutional issues touched on every aspect of DAC. Thus, the discussion was difficult to monitor, and the conclusions reached by the group tended to be rather general.

7.5.1 Revised Definition Statement - Economic and Institutional Issues

The chairman and the participants did not discuss the definition statement of economic and institutional issues. However, the session worksheets that were returned led to a revised definition as follows:

Economic and Institutional Issues can be categorized as either constraints or opportunities. In the DAC workshop emphasis is placed on those economic and institutional issues that serve as constraints or provide opportunities for desired changes in utility systems. Some examples of economic and institutional issues are:

- (1) Economies of scale vs. improvements in reliability, etc.
- (2) Availability of capital funds.
- (3) Availability of operating funds.
- (4) Most effective use of financial resources.
- (5) Conflicts between the actual costs of providing service and the tariffs designed under a social concern or other such criteria.
- (6) Regulatory constraints on innovative arrangements for unconventional energy resources.

- (7) Assessment of priority of service to customers and customer classes.

The DAC systems of the future will require the elimination of constraints and may require the use of economic and institutional innovation.

7.5.2 Major Statements

- (1) The closer we can get to controlling discretionary segments of customer's loads, the more we can minimize social impacts when system problems and emergencies arise.
- (2) The potential ability to control discretionary loads should be a major motivation for utilities, customers, and regulators to accept DAC.
- (3) Regulators and politicians often mandate utility activities prematurely. The resulting unworkable standards make it difficult to educate customers to accept load management and DAC.
- (4) The regulators and the utilities must work together to develop a common data base for decision making. Such a joint effort may result in decisions that both the regulators and the utilities find acceptable.
- (5) Customer education regarding the value of service reliability should include load management and energy conservation topics.
- (6) There may be occasions when legislation calls for standards to be established for some inappropriate objectives. The utilities must strive to avoid this by the proper education of the public.
- (7) DAC must be justified from the systems point of view, but utilities, under pressure from regulators, tend to install equipment to meet only current needs. DAC equipment functions are often evaluated independently, without regard to longer range utility DAC system needs; this lack of coordination frequently results in higher costs.
- (8) It is essential to quantify the potential value of DAC as much as possible. However, it may be acceptable to utility executives and regulators to install a more flexible DAC system than necessary without complete economic justification "as an insurance policy." The

"insurance policy" would be available to meet future requirements or unexpected contingencies which are not understood at the time a decision to install a DAC system is made.

- (9) Most DAC equipment will be installed as the need for the different functions materializes. Care must be taken to ensure that the equipment, such as load control devices, will integrate in the ultimate DAC systems.
- (10) Regulators often have objectives that differ from those of the other groups involved, including the public.

7.5.3 Discussion

Discussion centered on the following topics:

- (1) Justification of DAC.
- (2) The influence of load management on DAC.
- (3) DAC equipment installation.
- (4) Key issues and uncertainties.

Justification of DAC

The participants felt that so far it has been difficult to justify DAC economically. However, individual parts of the load management system, for example, can be justified. Participants felt that it was necessary to look at the overall system, rather than just one expensive element of the load management system, for example. Several reasons were offered why it is difficult to justify DAC:

- (1) DAC systems are expensive.
- (2) DAC systems are new.
- (3) People are not convinced that use of DAC will become widespread.
- (4) Managers lack evidence of operational savings to be derived from installing DAC.
- (5) Many of the perceived intangible DAC benefits are difficult to associate with dollar values.

- (6) Evaluation issues are complex.
- (7) People perceive major changes coming in energy policy that will affect the needs and requirements for DAC.

A representative from DOE recommended that the utilities justify the individual pieces of DAC, while keeping their eye on the whole system. The result would be that the pieces which are implemented will be likely to fit into the ultimate DAC system. It was emphasized that demonstration projects provide experience and systems data which often paves the way for wider acceptance in the industry.

Influence of Load Management on DAC

A great deal of active discussion occurred during this part of the session. The following questions were heard repeatedly:

- (1) Do load management requirements necessitate the use of DAC or does DAC necessitate use of load management methods?
- (2) When justifying today's load management project, do we need to look at installing DAC systems in the future?
- (3) What are systems operation versus future planning considerations?

It was agreed that today no one is looking at DAC as a whole. Each utility is doing the part of DAC that suits its own needs. The DOE representative said that DOE is planning for a demonstration project with TVA. The project will eventually demonstrate DAC systems installed in a selected distribution system. One participant suggested the following criterion: the ability to get a signal through to switches even when feeder lines are down.

A comment was made that we are "jumping the gun," because we are trying to include too much of the future in today's planning. Some participants felt that load management must be addressed now, but that DAC's time and place is in the future.

Several participants felt that the utility industry will not get appreciable results from DAC until 1983.

DAC Equipment Installation

One participant asked, "Has anyone installed DAC equipment?" The response was no. He added that it appears that DAC would be installed first at the substation and then on the customer's premises. Another participant noted that, from a load management point of view, perhaps DAC should be installed on the customer's premises first and then at the substation.

A participant pointed out the risk of installing equipment today that may not be usable tomorrow. There was agreement that today's needs must be taken care of today, even if the equipment chosen may be obsolete tomorrow. Some participants felt that, preferably, DAC systems should be installed at commercial and industrial sites first. These customers have larger loads, are fewer in number, and are easier to deal with in negotiations. A participant commented that, as DAC is installed, the utility industry needs to make sure that components on the customer's premises do not have to be replaced in the future because of utility mistakes in DAC equipment selection. One way to do this is to keep components simple. The participant commented that it is all right to replace central components. Some participants expressed doubt that discussions of DAC with customers would elicit a supportive response. However, participants acknowledged that industrial customers are more sophisticated than residential customers. Comments followed describing the City of Burbank's success in gaining industrial community support for a load management program designed to avoid rolling blackouts. The City of Burbank made an appeal to good citizenship in conjunction with self-interest. For example, the Burbank Public Service Department has a verbal agreement with Lockheed to shed part of Lockheed's load under specified conditions. Under emergency conditions, the Public Service Department will eventually be able to reduce Lockheed's load first by about 5%, and if the emergency condition persists, by a total of about 10%. It was pointed out that essential loads associated with industrial processes should not be under public utility control.

Several participants felt that there were pressures to make planned load management systems fit with future and potentially available DAC systems. One participant commented that the real value of putting in DAC now is to start training people. He felt that even though the DAC equipment installed today will soon be obsolete, the industry must take the step now.

Key Issues and Uncertainties

The following key issues and uncertainties were identified and discussed by the participants:

- (1) Will regulators allow or demand DAC?
- (2) If the time to implement DAC is not now, but in the future, what can we do today to prepare for the future?
- (3) How can the industry develop an interface among utilities, customers, and regulators?
- (4) How can presently-installed pieces in a load management system be made to best contribute to the ultimate DAC system? How can the industry minimize the likelihood of being trapped by inadequate components, especially on the customer end?

- (5) How can regulators get all of the facts prior to mandating standards and other rulings? How can the regulatory/utility industry interface be improved?

The discussion of key issues and uncertainties concluded the session.

7.6 DAC CONTROL HIERARCHY WORKING SESSION

Chairman: Dr. Fred Schweppe
Electric Power Systems Laboratory
Massachusetts Institute of Technology

7.6.1 Definition Statement - DAC Control Hierarchy

Control Hierarchy (CH) of highly integrated, advanced systems is an extremely complex field. The following introduction to Control Hierarchy from Fact Sheet 6 of the DAC Working Group Information Booklet (see Appendix D) illustrates the numerous areas involved in DAC system Control Hierarchy.

DAC Control Hierarchy is a determination of the priority for access and control by the DAC system among the four technical motivations should a conflict for access arise. The DAC control hierarchy would be interfaced with the system benefits. As an example, if actions calling for load control simultaneously with service restoration following a fault were received at a distribution substation, the service restoration action would prevail. Some local grouping of control functions could minimize such conflicts.

Another aspect of control hierarchy is the distributed nature of processing of information desirable to minimize competition for vertical communication links...

There is a hierarchy of control systems and subsystems which can be viewed as an arrangement based on authority and the special right to override or interrupt the actions of other systems...

Another aspect of the DAC Control Hierarchy involves location of functions and the physical relationships of elements of the hierarchy to "control centers" and human operators...

Yet another aspect of the DAC Control Hierarchy involves consideration of the frequency of actions, number of points controlled or monitored, and the total information processing requirements...

The last aspect involves the creation of boundaries within which decisions can be made without reference to higher authority...

7.6.2 Scope of Session

Insufficient time was available to permit the group to discuss all of the issues related to all of the subtopics included in the "definition" of control hierarchy. In an effort to condense the task of the session down to a manageable size, the chairman prepared a number of worksheets and predetermined the areas to be discussed. He indicated that the discussion would not include the following categories:

- (1) Communication hierarchy:
 - (a) Hardware.
 - (b) Software.
 - (c) Routing of data and signal traffic.
- (2) Relaying and switching by microcomputer.
- (3) Transient, dynamic system stability issues.

The group was not in full agreement with dropping all of these areas from discussion, but accepted the constraint, realizing that time limitations made a reduced scope essential.

7.6.3 Working Outline

Dr. Schweppe proposed a system consisting of

- (1) A three-dimensional hierarchy.
- (2) Two-part control.
- (3) A number of modes of operation.
- (4) Four basic models of response.

These elements were then configured into separate worksheets for the Decision Making System and Information Processing System of the overall DAC Control System.

The following outline was developed by Dr. Schweppe and handed out to the session to clarify the component areas of the system approach he proposed.

Three-Dimensional Hierarchy

- (1) "Priority" of Functions.
 - (a) Load Management (LM).
 - (b) Unconventional Energy Resources (UER).
 - (c) Distribution System Management.
 - (d) Preventive, Emergency, and Restorative State Control (PERSC).
- (2) "Location" of Function.
 - (a) Usage device.
 - (b) Customer.
 - (c) Feeder.
 - (d) Substation.
 - (e) Distribution Control Center.
 - (f) Bulk System Control Center.
- (3) "Time Response" of Function.
 - (a) 0 to X seconds.
 - (b) X seconds to 1 minute.
 - (c) 1 to 5 minutes.
 - (d) 5 minutes to 1 hour.
 - (e) 1 hour to 1 day.
 - (f) 1 day to 1 week.

Two Part Control System

- (1) Information Processing System (converts data into model)
- (2) Decision-Making system (uses model to make decision for an action)

NOTE

The Decision-Making System logic depends heavily on the "function" involved whereas the Information Processing System is somewhat independent of the "function" since the same model will be used at various times to make different decisions.

Modes of Operation

- (1) System Modes.
 - (a) Normal.
 - (b) Emergency.
 - (1) Bulk System.
 - (2) Distribution System.
 - (c) Restorative.
 - (1) Bulk System.
 - (2) Distribution System.
- (2) Information Processing System Modes.
 - (a) Valid Model.
 - (b) Invalid Model.

Models (to be developed in the Information Processing System)

- (1) Power Demand/Generation (KW and VAR).
 - (a) Type
 - (1) Explicit.
 - (2) Statistical.
 - (b) Properties.
 - (1) Time dependence.
 - (2) Response to control.
 - (3) Weather dependence.

- (c) Level (location)
 - (1) Usage device.
 - (2) Customer.
 - (3) Feeder.
 - (4) Substation.
- (d) Time Span.
 - (1) 0 to 1 minute.
 - (2) 1 to 5 minute.
 - (3) Etc.
- (2) Network Configuration/Status.
- (3) Network State.
 - (a) Voltage.
 - (b) Line flows.
 - (c) Etc.
- (4) Weather.

7.6.4 Session Worksheets

Results

Following a review of this material, the group was asked to fill out a matrix to develop some design parameters and hierarchy recommendations for the Decision-Making System. Tables 7-1 through 7-3 present composites of the group's efforts to complete the matrixes, based on the assumption that the models recommended are all valid.

Additional Considerations

Here are some statements by group members that should be taken into consideration when the results in Tables 7-1 through 7-3 are reviewed:

- (1) Time constraints did not allow the group to address the specific hierarchical control issues of precisely what decision is made, where and when.

Table 7-1. Decision-Making System: Normal Mode

	LM	UER	DSM	PERSC
Priority	Under normal mode - can function in all areas. Focus on preventive.			
Location (where decision is made)	Bulk Control Center (implemented at lower levels)	Bulk Control Center or customer (no group consensus)	Distribution Dispatch Center and feeder or customer	Bulk System and/or Distribution System (as needed)
Time Response	10-15 minutes to 1 hour	10-15 minutes to 1 hour	1-2 minutes to 2 minutes	15 minutes to 1 hour
Models Needed	Weather, load	Weather, load (depending on where decision is made)	System configuration and state, voltage, load	System state, system configuration

- (2) The analysis considered only utility systems with generation, and took no note of utility systems without generation.
- (3) The discussion seemed to be weighted toward the bulk system point of view. This preference seems to conflict with one of the conclusions developed in the impact on System Design Session - specifically, that decisions should be made as far down the system as possible (see Section 7.7).
- (4) The effect of penetration of DSG and UERs was minimized.

Table 7-2. Decision-Making System: Emergency Mode - Bulk System (EB), Distribution System (ED)

	LM	UER (utility owned)	DSM	PERSC
Priority (1 = low, 10 = high)	2 (EB)	1 (EB) (if generation available)	9 (EB)	10 (EB)
	3 (ED)	3 (ED)	1 (ED)	1 (ED)
Location	Bulk Control Center (EB)	Central Dis- patch Center for supply, customer for demand (EB)	Bulk System (EB)	Bulk System (EB)
	Distribution System (ED)	Distribution System (ED)	Distribution System (ED)	Distribution System (ED)
Time Response	$\frac{1}{2}$ to 15 minutes (EB)	$\frac{1}{2}$ to 15 minutes (EB)	$\frac{1}{2}$ to 15 minutes (EB)	$\frac{1}{2}$ to 15 minutes (EB)
	15 minutes (ED)	15 minutes (ED)	15 minutes (ED)	15 minutes (ED)
Models Needed	Load, voltage frequency de- pendence (EB)	Capacity (EB)	Capacity (EB)	Capacity (EB)
	Voltage pro- file, line segment, grid system (ED) (lack of consensus on this point)	Same as for LM (ED)	Same as for LM (ED)	Same as for LM (ED)

Table 7-3. Decision-Making System: Restoration Mode - Distribution System Only

	LM	UER (utility owned)	DSM	PERSC
Priority (1 - low, 10 - high)	2	2	1	1
Location	Distribution Dispatch Center	Same as for LM	Same as for LM	Same as for LM
Time Response	$\frac{1}{2}$ to 2 minutes ($\frac{1}{2}$ day for storm- related faults requiring crew action in field)	Same as for LM	Same as for LM	Same as for LM
Models Needed	Circuit config- uration, load	Same as for LM	Same as for LM	Same as for LM

7.6.5 Discussion and Major Statements

The group, in the process of completing the decision-making system tables, brought up some points that should be noted. In this Working Session almost no statement received universal endorsement. This disagreement was in itself perhaps the most significant single statement of the group. Control hierarchy is a very basic issue, and the decisions that a utility makes in this area tend to reflect its perspective or philosophy of power system operation and emergency response. The disagreements expressed in the session suggest that DAC systems should be developed with enough flexibility to adapt to the various control philosophies of different utility companies. As was asserted in the Functional Requirements Working Session (Section 7.4), there are inherent differences between utilities; they probably will never apply the same solutions in all DAC-related areas. Therefore, any new systems that attempt to impose general solutions on the utility industry - solutions that do not allow for individual differences - will most likely be rejected.

The following statements emerged from the group's discussion:

- (1) Emergencies can originate from many sources:
 - (a) Equipment failure.
 - (b) Overloads.
 - (c) System faults which can cause equipment failures.

- (2) When an emergency arises from a major equipment failure, the restoration may or may not be improved by use of DAC.
- (3) Control of UERs poses many hierarchy problems and questions related to the distribution system. These issues must be clarified and answers sought which will be acceptable to non-utility owners.
- (4) DAC systems could very likely reduce the number of minutes of customer outage and the number of customers affected by an outage during an emergency.
- (5) The viability and effectiveness of voltage reduction as a short "time response" function is not clear and should be investigated.
- (6) DAC system could assist in the following functions:
 - (a) Fault diagnosis (possibly).
 - (b) Data base management.
 - (c) Establishment of restoration priorities.
 - (d) Improve overall system reliability.

Throughout the session the discussion tended to center on issues that would be involved in system response during preventive, emergency or restorative states.

7.7 IMPACT ON SYSTEM DESIGN WORKING SESSION

Chairman: Orville L. Hill
Senior Electrical Engineer
Pacific Gas and Electric Company

7.7.1 Definition Statement - Impact on System Design

The group felt that the definition statement in Fact Sheet 8 of the DAC Working Group Information Booklet (see Appendix D) was too long, but made no specific changes to it. It is partially restated here as reference information.

System Design involves the selection and arrangement of components and their interconnection based on operating practices, economic evaluations of components and configurations, and criteria based largely on experience. New communication and control tools will allow for load

patterns never before experienced, impacting economic component selection and configuration, but will also enable the monitoring of these load patterns to aid in future system design...

7.7.2 Major Statements

In its discussion the group reached only one significant conclusion: The basic design concepts of future distribution systems employing DAC technology will differ little from those of present day systems.

Otherwise, the discussion did not reach any other far-reaching recommendations, issues or statements. The group's discussion covered a variety of topics and produced a number of points:

- (1) Changes in system design will come slowly as reaction to new developments and experience with advance electronics technology.
- (2) There will possibly be a trend to higher voltages and to increased diversity within the distribution system.
- (3) The penetration of advanced equipment systems in certain areas is not now technically limited but market limited.
- (4) Once a market is demonstrated, standard equipment units should be repackaged to include the DAC control and communication devices as an internally integrated part of the unit.
- (5) Harmonics and line noise will pose a problem. However, alteration or limitation of customer's freedom to operate noise producing devices on line by means of regulations should not be viewed as a viable solution. The goal should be to minimize forced changes at the consumer level.
- (6) DAC opens the door to implementation of large battery storage at substations or even on distribution feeders.
- (7) Batteries and other DSG sources should be viewed as having multiple functions for both peak shaving and emergency fault restoration, but these should be utility controlled.
- (8) There is a need for reliable, inexpensive microprocessors for local control. Also needed are very low cost, moderately accurate transducers for remote detection and transmission of system data on

Watts
VARs
Voltage
Current
Temperature

- (9) Distribution system design will not change rapidly or radically. The introduction of dispersed storage and generation will be facilitated as the communication technology, devices and transducers become more reliable and less costly.

7.7.3 Discussion

The participants felt that the definition statement encompassed such a broad area that it precluded a meaningful answer to the question, "What impact will DAC have on system design?" The group concluded that the overall impact on system design would be minimal. A number of specific topics were then discussed. Numerous issues were considered in these areas, but a consensus was seldom reached, and the issues were not considered to be of great importance by the session participants. The following statements were made by the group:

Harmonics and Noise

- (1) It should be determined what noise problems will be encountered as the new dispersed generation units come on line and how the system will respond.
- (2) Some major noise producers may have to be retrofit to avoid interference, especially with high-frequency communication systems.
- (3) Most of the group felt that the utilities should not try to limit certain customer load types, even if harmonic-producing loads proliferate.

Dispersed Generation and Storage (DSG) and Two-Way Power Flow With the Customer

Much of the discussion directly or indirectly focused on how the utility system should be adapted to accommodate DSG. There was much agreement that the utilities needed to maintain control of power entering the grid. DSG was seen to bring new problems which could affect system design, including

- (1) Generation planning.
- (2) Voltage and frequency control.
- (3) Equipment ownership and maintenance.

- (4) Fault liability and restoration procedures and responsibility.
- (5) Generation reliability must be assured to customers served primarily from DSG sources, via advanced controls.
- (6) Power dispatching and scheduling.
- (7) Extended remote feeder switching needs.
- (8) Special rates for DSG customers, to be developed along with incentives for the generating customer to permit a high level of control to the utility.

Batteries

Batteries were discussed a number of times as potentially advantageous storage mechanisms.

- (1) Large remote batteries on feeders could almost simulate a substation. This could be helpful where there is no nearby transmission line, but it would require remote control of inverters, etc., which is not yet developed.
- (2) Batteries could aid in (a) flattening peaks and (b) providing system disturbance solutions.
- (3) Special intelligent DAC synchronizers should be designed to assure that battery inverters always reclose in phase.

New Equipment

It was realized that DAC could change not only the overall system design concept but alter the specific components. In fact, component modification would most likely appear well before a highly DAC-impacted "system design." Some components issues are

- (1) New types of power transformers should be designed for improving thermal operation to improve load factors and use communication systems for real-time temperature monitoring.
- (2) A new generation of sectionalizing switches should be developed for complex automatic or "smart" assisted re-routing procedures.

- (3) Automatic/remote transfer of radial taps could start.
- (4) Fusing as we know it may disappear.

Penetration of Microprocessor Technology

The microprocessor, solid-state, control electronics field has been subject to rapid development in the last decade. The group discussed how this technology may affect areas of distribution system design.

- (1) "Smart" devices may be designed to change current concepts of:
 - (a) Reclosers.
 - (b) Fuses.
 - (c) Regulating equipment.
 - (d) Others.
- (2) DAC systems design will be based on minimizing the communications requirements among the control center and local control locations dispersed throughout the distribution system.
- (3) Control systems must be designed with the capability to remotely override the local decision-making of microprocessors from more central control centers.
- (4) Modern electronics will first impact communications and control systems; then individual equipments in the distribution system; and, lastly, overall distribution system design.
- (5) DAC systems may improve operations in the distribution system in a number of ways:
 - (a) Detection of power theft.
 - (b) Fault location.
 - (c) Data retrieval for generation planning and scheduling.
 - (d) More precise voltage control.
- (6) To facilitate DAC penetration at lower levels in the distribution system, low cost transducers must be made available for power, current, voltage, temperature, etc., monitoring and data acquisition.

General

The group found many areas where the distribution system elements could be affected, but did not expect to see significant changes to basic design (e.g., departures from network or radial configurations, etc.).

7.8 COMMUNICATION ALTERNATIVES WORKING SESSION

Chairman: John B. Blose
Senior Engineer, Energy Distribution Research
Philadelphia Electric Company

The participants set four objectives for the session:

- (1) List communications alternatives.
- (2) Identify present activities.
- (3) Discuss required channel capacity.
- (4) Discuss key issues and uncertainties.

7.8.1 Definition Statement - Communication Alternatives

The group did not revise the definition statement, even though some felt that it was restrictive. The definition presented here is taken, in its entirety, from the Fact Sheet 7 on Communication Alternatives in the DAC Working Group Information Booklet (see Appendix D).

The DAC systems of the future will require that substantial amounts of information and control instructions be conveyed among centralized control facilities, dispersed remotes and even individual devices. This extreme dispersion of controlled devices and telemetry points has a significant impact on the methods to be used for conveying information. Also, the paths for information must be capable of bidirectional as well as unidirectional flow. Further impacting the selection of communication alternatives is the need for security of information flow, and the avoidance of interference with (and from) other systems. The alternatives presently being considered include

- Radio.
- Power Line Carrier.
- Telephone, Communication Utility System.

- Telephone, Power Utility Owned.
- Microwave.
- Satellite.
- Fiber Optics.
- Hybrid (any combination of more than one of the above).

7.8.2 Major Statements

- (1) More attention should be directed to (a) the meter reading function, not only at residences, but also at commercial and industrial sites and (b) controlling interruptible loads and monitoring load deferral compliance.
- (2) The meter reading function is more important than ever, owing to the advent of time-of-day rates and increasing manual reading costs.
- (3) Research and development projects on DAC communication alternatives have been under way for some time, and there is a need to disseminate the results from these projects. This will help to avoid duplication of effort.
- (4) Several utilities are currently enlisting support from their customers as volunteers for DAC communications experiments.
- (5) Concern was expressed by some participants regarding "going beyond the meter" with monitoring and decision-making. They thought that the best way to influence customer demand for electricity is to set demand rates and let the economic factors control loads to the appropriate levels. Others thought that load management by incentives without control would prove futile.

7.8.3 Discussion

The group discussed communication alternatives, present activities, and key issues and uncertainties. Several communications alternatives and activities were discussed including:

- (1) Power line carrier: At least 10 trials now active.
- (2) Two-way UHF/VHF: One EPRI/DOE trial; one commercial.

- (3) Radio/carrier hybrid, one-way: Several test and commercial installations.
- (4) FM radio, SCA, one-way: Developmental.
- (5) AM radio, subaudibles, one-way: Developmental.
- (6) AM radio, carrier modulation, VHF return, narrow-band: Developmental.
- (7) 60 HZ system, voltage and current wave distortion: Under test.
- (8) "Ripple" systems, one-way, developing return techniques: Commercial.

It was pointed out that a commercial AM radio, subaudible tone installation exists in the Ontario Hydro System for one-way load control. The ALTRAN Radio Control and Metering System was discussed. This system consists of two-way communication links. The "Forward" link utilizes existing AM broadcast stations to transmit low rate (16 bits per second) control signals by phase modulation of the AM carrier. The Forward link modulation sidebands remain well within the subaudible regions (below 20 Hz) of AM channel. The "Reverse" link utilizes a radio channel (e.g., at VHF). The user messages are relatively short (30-60 bits) and are assigned a unique slot of time and frequency. Mr. Louis Martinez is president of the ALTRAN Company, which is located in Torrance, California. Another related project, sponsored by the Electric Power Research Institute, involves a UHF application at about 950 MHz using a two-way radio. Motorola is apparently negotiating with a Georgia utility company for an installation at about 950 MHz.

A member of the session asked if there are any DAC activities related to microwave technology. The consensus appeared to be no.

Communication alternatives involving telephone systems were discussed. One test of telephone systems is being conducted by EPRI/DOE, and the telephone companies seem to have a growing interest in this field. A participant mentioned the DOE-funded DARCOM/Omaha Public Power District installation, which appears to be proceeding with success. A representative from Ontario Hydro said that in late fall there will be an extensive test involving 500 points in Canada. Bell of Canada and some manufacturers will participate in the test. This test involves a microprocessor scanner and a direct coupler into the customer's line, bypassing the switching equipment within the telephone companies. The objective is to scan each point every 5 minutes. The representative from Philadelphia Electric said that telephone companies are developing a system for control with the subscriber's telephone either on or off hook. The representative from San Diego Gas and Electric asked about the scan rate of the available telephone systems. He also asked about the purpose of the extensive test in Ontario, etc.? No conclusive answers were offered.

Next, the group discussed power line carrier (PLC) systems. Three tests are currently in progress under EPRI/DOE sponsorship, and

General Electric has trials under way with six utilities. Participants in those tests include Duke Power, Georgia Power, Philadelphia Electric, Commonwealth Edison, Pacific Gas and Electric, Consolidated Edison, and DelMarVa Power. A representative from Niagara Mohawk discussed Phase Three of the GE project, which includes microprocessors in the sub-station. A representative from Pacific Gas and Electric commented on a demonstration of the Rockwell PLC system. Mention was made of the American Science and Engineering system at Jersey Central Power and Light. This system includes 1,000 points, time-of-day meter reading, and load research, and involves six substations. Also, reference was made to a PLC project involving American Electric Power with Automated Technology Corporation, which is now on line. Other joint manufacturer/utility trials include Consolidated Edison with Hazeltine, and Florida Power Corporation and Florida Power and Light with American Science and Engineering in a PLC project. New England Power Service has developed a prototype for a unique power system concept (TWACS). Emerson Electric is designing a second generation prototype to be demonstrated in the near future. A wide range of functions will be involved and the system will be bidirectional.

Next, the participants discussed ripple. Manufacturers of ripple control equipment, as identified by meeting participants, are Weston-Schlumberger, Landis and Gyr, Plessey, Brown-Boveri, and Siemens. Some of these companies are developing practical feedback systems.

Next, the participants discussed coaxial cable. There were some references to Hughes in El Segundo, California, but no specific information was offered. One participant identified franchises and politics as major problem areas.

In regard to meter reading, the representative from Northern States Power pointed out that the data rate of the communication channel can limit the performance of the system. His feeling is that the best approach will involve "significant intelligence" at the customer's meter and only periodic reporting to the utility central computer. This approach allows use of relatively slow but secure data channels.

The following new key issues and uncertainties were identified and discussed by the participants:

- (1) More frequencies for utility system communications are needed. It is not clear what agency or group is responsible for frequency spectrum allocation and management for PCL. J. Loferski stated that he is Chairman of the Utilities Telecommunications Council (UTC) Load Management/Distribution System Automation committee and that his committee was considering this issue. He said the 10 kHz to 190 kHz portion of the spectrum is currently in use for PLC. This use may not be allowed to continue, since there has been no specific allocation by the FCC for PLC use within this range. He said there are 26 frequencies identified as required for power systems. The group felt

that the efforts initiated and pursued by the Utility Telecommunications Council to obtain additional frequency allocations should receive additional support. The participant from Ontario Hydro said he had some interest in an 8.2 kHz tone system and saw some possible conflicts with other uses.

- (2) It is not clear whether it is necessary for the utility to own the communication system or if telephone systems can be used. It was pointed out that both the power and telephone companies are regulated by the PUC, so there should be a basis for common use of equipment.
- (3) A sub-issue arose regarding simultaneous power and telephone outages. The Pacific Gas and Electric representative commented that they found no correlation in a study with which he was familiar.
- (4) Channel capacity issues, identification of functions, and other requirements need to be resolved.
- (5) Will crosstalk or interference with other communications systems exist in DAC applications, and if so, to what extent will it affect the quality of communications? What studies are needed in this area? What guidelines or standards are necessary for customer-generated interference?
- (6) How can utility companies deal with customer interference?
- (7) Harmonic distortion is a concern in this area.

The discussion concluded with a comment by the chairman, about the GE distribution system RF modeling contract and the Compu-guard work on noise on the distribution system, both active projects funded by DOE. He said that the hardware and techniques resulting from these efforts should be useful for analyzing and testing utility power systems, as soon as the projects are completed and final reports released by DOE.

7.9 NEW SOURCE INTEGRATION WORKING SESSION

Chairman: Thomas W. Reddoch
Associate Professor, Dept. of Electric Engineering
University of Tennessee

The procedure used in this session was to

- (1) Identify issues.
- (2) Discuss activities to resolve the issues.
- (3) Discuss DAC's role in new source integration.

7.9.1 Definition Statement - New Source Integration

The chairman and the participants did not derive a definition statement for new source integration. The definition presented below is taken from the Fact Sheet 10 on New Source Integration in the DAC Working Group Information Booklet (see Appendix D).

Technical and economic problems resulting from increasing demand for electrical energy and the growing scarcity of oil and natural gas are forcing the shift to energy conservation techniques such as cogeneration and to the utilization of unconventional energy sources such as solar and wind power. Coupled with these developments are techniques for storing energy during periods of light load demand. The development of these new technologies and the integration of them into the utility system require new technological advances and present new design problems to the utility engineer.

The development of Distribution Automation and Control (DAC) is required for the integration of new sources within the utility distribution system. DAC will provide the communications, power processing, automation, control and protection, required when unconventional energy sources such as fuel cells, photovoltaic, solar thermal, wind, geothermal, and batteries, are integrated into electric utility distribution systems.

7.9.2 Major Statements

Emphasis should be placed on the near term application of unconventional energy resources (UERS) on the electric utility system. In general this suggests low overall penetration; however, local concentrations may be significant.

- (2) It is generally conceded that effective integration of UERs can be aided through DAC. Inventory, control, economic dispatch, and safety of UERs can be enhanced throughout the communications and control systems of DAC.
- (3) The advent of UERs is imminent; the position of discouraging the integration of UERs is no longer acceptable. Rather, a positive attitude which seeks definitive answers to fundamental questions is recommended.
- (4) DAC is not essential for near-term integration of new energy sources. However, when the penetration of new sources reaches significant levels of total substation peak demand - which level is yet to be determined - DAC could assist in system operation.
- (5) New source integration should be approached from the standpoint of minimizing overall costs to the consumer while displacing the use of critical fuels.
- (6) Interaction between unconventional energy sources located in close proximity to each other should be investigated from the standpoint of dynamic stability.
- (7) The quality of the power being delivered to neighboring customers can be impacted. Caution should be exercised in interfacing unconventional energy resources with the distribution system.

The chairman suggested that the electric utility industry begin a program for the accommodation of UERs.

7.9.3 Discussion

As a basis for the discussion, three assumptions were made to permit consistency in the recommendations:

- (1) All equipment is assumed to be tied directly into the utility system and is under utility control.
- (2) Concepts should represent a near-term fix rather than a global, long-term solution.
- (3) Control should trip all UERs in event of the loss of central station power.

Although these assumptions may be limiting in many respects, they do represent a position which is necessary for near-term accommodation of UERs.

It was decided that discussion would center around the following issues with wind technology as the focal point:

- (1) Safety.
- (2) Cost of back-up and buy-back.
- (3) Control.
- (4) Power conditioning.

The chairman described wind generators that fall into small, intermediate, and large categories. He explained that small machines are less than 100 kW. They are typically available in 1, 8, and 40 kW units. In the intermediate class, there is one 100 kW unit, built by NASA in Ohio; however, several 200 kW units are currently under construction and test operation. A large, 2000 kW, machine is under construction in Boone, North Carolina, and will be placed in operation in May 1979. A 2500 kW demonstration is planned for early 1980. He said that a great deal of demonstration field data has been accumulated for wind generators. In fact, there are a number of wind machines tied in now to utility electric grids in the United States. Some are owned by the utility company and others are owned by customers.

The point was emphasized that safety issues deal with protection of people as well as equipment. The comment was made that the simplest protection is to trip the interconnect between the customer and the utility when the utility line fails.

A participant mentioned the potential for problems with line commutated converters. It was mentioned that each utility needs to create a standard procedure for interconnecting with customers who are generating electricity on-site. A comment was made that surge interface specifications need to be developed to define maximum surge levels at the interface between the electric grid and the customer's equipment. It was pointed out that the independent generator must accept broader responsibilities, if he agrees to be interconnected to the utility electric grid system. As a result, the independent generator may, under certain conditions, be held liable for safety or other problems on the grid caused by his generating equipment. It was pointed out that an "interface" specification should include:

- (1) Frequency droop characteristics.
- (2) Reactive power control requirements.
- (3) Frequency synchronization and disconnect procedures.

The participants concluded that the utility industry and the owners of UERs must deal with third party liability related to system failure, surge or other problems caused to neighboring utility customers. A neighboring customer could be affected when an event

originating at an UER transmits "effects" through the utility interface. It was pointed out that DAC technology can not deal effectively with transient stability problems; however, DAC can assist in dealing with long-term dynamic problems.

The following key issues and uncertainties were identified and discussed by the participants:

Safety

- (1) Utility personnel should be guaranteed protection. For utility controlled devices, this problem is minimized, if not eliminated.
- (2) Equipment attached to the utility system must have protection. This can be achieved by an appropriate interface between the UER and the electric utility system.
- (3) If a unit is tied to the utility grid and the unconventional energy resource is on line to serve the load, who is responsible for safety problems associated with customer owned generators and devices?
- (4) Other customer's loads and other UERs must be protected at all times.
- (5) The UER must be protected against surges due to switching or lightning.
- (6) A new protection philosophy for the distribution system must be developed since faults can be fed from both directions.
- (7) Classical distribution systems use a simple overcurrent protection system with a unidirectional protection philosophy; however, UERs will call for bidirectional protection.
- (8) Each utility should develop a standard customer specification for the purpose of interconnecting UERs.
- (9) If UERs are not to be removed from service when central power station power is lost, many unresolved issues will exist, and what the liabilities will be in such circumstances is as yet undetermined.

Cost of Back-up and Buy-Back - An Issue Related to the Economic Feasibility of UER Applications

- (1) It is recommended that rates for sale of basic electric service to customers with UERs be established on an experimental basis to permit assessing the actual cost of serving the customer.
- (2) A rate for buying excess power from UERs should be established. It should be on an experimental basis.
- (3) Customers with storage capability and load management systems should be given preferential rates for their UER systems when the collective systems can be effectively coordinated.
- (4) DAC systems can be effective in resolving some of the rate issues because of associated information retrieval systems and the control capabilities.
- (5) Rates involving UER customers affect all utility customers.

Control Issue

- (1) The control and dispatch of UERs can greatly be enhanced by DAC.
- (2) DAC can be vital in the effective integration of UERs and storage into a coordinated system and optimal use of the power output of the UER.
- (3) DAC can minimize problems of dynamic interaction between UERs and the electric system through control.
- (4) Reactive power control should be aided through DAC.

Power Conditioning

- (1) Many of the UER systems produce dc power, thus requiring an inverter system to provide ac power. Both forced commutated and line commutated systems are available. The latter system has the advantage of tripping the system upon loss of central station power.
- (2) Some commercially available converter systems produce an excess of harmonics. These can affect telephone systems as well as communication systems associated with DAC.

- (3) The development of interfacing standards will be necessary.
- (4) Since UERs may require converter systems, those units located at the end of long feeders may require special attention.

APPENDIX A
CURRENT PROJECTS AND ACTIVITIES

APPENDIX A

CURRENT PROJECTS AND ACTIVITIES

Detailed information on the projects listed here may be obtained by contacting the representatives of the organizations involved who attended the DAC Working Group meeting (see Appendix D). Note that this list is not a comprehensive DAC, RD&D reference, but simply a list of activities identified by the participants during the DAC Working Group meeting.

DEMONSTRATIONS

Load Management

- (1) Southern Maryland Electric Corporation is installing time-of-day meters and is planning to initiate a load management program within one year, by order of the Public Utilities Commission.
- (2) Wisconsin Electric is implementing a full scale water heater control project, including two-way communications.
- (3) Northern States Power is performing a demonstration of a variety of "controllable loads" for potential load management.
- (4) Oak Ridge National Laboratory is managing a number of load management demonstrations including large scale system demonstration with the Tennessee Valley Authority.

Dispersed Storage and Generation

- (5) Niagara Mohawk is conducting a 4.5 MWe fuel cell demonstration at the Olympic Village.
- (6) Northern States Power is demonstrating design concepts for space heating, thermal storage, and wind-mills for residences.

Communication Systems

- (7) Philadelphia Electric Company is performing a field trial of 50 GE AMRAC units in two test areas, and a large scale pilot program.

- (8) General Public Utilities Service Corporation is performing a 1000 point communication demonstration.
- (9) Omaha Public Power is demonstrating DARCOM telephone line communication systems for metering and control.
- (10) Ontario Hydroelectric is managing two projects, one for AM radio and one for phone line systems.
- (11) Pacific Gas and Electric has been operating a telephone line-based system for 8 years.
- (12) Wisconsin Electric is analyzing two-way communications in conjunction with a water heater control project.
- (13) Northern States Power is involved in field tests of equipment by American Science and Engineering, Westinghouse, and ATC-Honeywell.
- (14) EPRI and DOE are performing a large scale demonstration of five communication system installations: three power line carrier, one telephone, one radio.

Control Systems

- (15) Florida Power Corporation's SCADA Project, due on-line in the second quarter of 1979, will interface with and become a satellite to the new FPC Energy Control Center.
- (16) Ontario Hydroelectric, with the Scarborough PUC, is implementing a demonstration of capabilities for a distribution automation system with two 27.6/16 kV feeders in Toronto, in the AMEU Distribution Automation Project.
- (17) New England Power Service is doing TWACS prototype tests and preproduction tests with Emerson Electric Co.
- (18) Niagara Mohawk is investigating integration of electric and gas grids and renewable sources.
- (19) Niagara Mohawk is installing a BEST (Battery Energy Storage Test) facility with Public Service Electric and Gas, to be completed in 1980.
- (20) Northern States Power is evaluating ripple control in conjunction with a power line carrier system.

STUDIES

Economic Assessment

- (21) Florida Power Corporation is performing a number of distribution automation, economic justification, and feasibility studies.
- (22) Niagara Mohawk is developing a method for DAC economic and engineering assessment.
- (23) Westinghouse has computerized economic evaluation techniques for storage and local control technologies.
- (24) General Electric is studying the economic benefits of automatic meter reading and remote control using power line carrier.
- (25) DOE has several studies in distribution system economics.
- (26) Massachusetts Institute of Technology's Electrical Power Systems Laboratory is developing advanced control system hardware components for implementation of "homeostatic utility control."
- (27) McGraw-Edison is attempting to quantify noise characteristics of certain system components.
- (28) DOE is evaluating transformer losses.

Communications Systems and System Control

- (29) American Electric Power is evaluating bidirectional control of remote feeder substations from their operations center.
- (30) DOE is performing a mathematical modeling feasibility study on using distribution feeders as a communication path.
- (31) American Electric Power is studying distribution line carrier data and communications system; "Residential Electric Heating Study #1 AMRAC."
- (32) McGraw-Edison is evaluating the reliability of communications systems.
- (33) American Electric Power is studying cold load pickup and the distribution of circuit demand following outages of 10-40 minutes.

Load Management

- (34) American Electric Power is looking at the load characteristics of 150 major electric appliances.
- (35) Oak Ridge National Laboratory is developing a load management assessment methodology.

Customers

- (36) American Electric Power is studying the load characteristics of 1500 customers, in all classes.
- (37) Ontario Hydroelectric is performing a door-to-door survey of customers and solicitation for participation in an experimental load management program.

System Specifications

- (38) Niagara Mohawk has begun to define specifications for computerized control systems including consideration of functions, hardware, and hierarchy.
- (39) Ontario Hydroelectric has prepared the first draft of a DAC system functional specification.

APPENDIX B
PARTICIPANTS - DAC WORKING GROUP MEETING

APPENDIX B

PARTICIPANTS - DAC WORKING GROUP MEETING

NOTES

Areas of interest are as indicated at the DAC Workshop.

"Emergency State Control" refers to control and monitoring actions related to events leading to and during disturbances and outages, and to restoration of services.

AMERICAN ELECTRIC POWER SERVICE CORPORATION
Verlin Warnock
Head, Distribution Engineering Section
2 Broadway
New York, New York 10004
Telephone: (212) 422-4800

Areas of Interest: Emergency State Control, Dispersed Generation

Activities include evaluation of bidirectional control of remote substation feeder breakers station from operations control center acquisition of circuit demand data to evaluate cold load pickup characteristics. A project to study the load characteristics of 1500 customers: all classes and load characteristics of 150 major electric appliances. Studying distribution line carrier data and communications systems, "Residential Electric Storage Heating Study #1 AMRAC." "Impact of Voltage Reduction on Energy and Demand," IEEE 1978 Winter PES Meeting Transaction Paper #78-015, Preiss, R. F., and Warnock, V. J.

BALTIMORE GAS & ELECTRIC
Bill Prince
Chief of System Operations
Gas & Electric Building
Baltimore, Maryland 21203
Telephone: (301) 234-5791

Areas of Interest: Emergency State Control, Reliability

BALTIMORE GAS & ELECTRIC
Ernest C. Dawson
Supervisor, Forecasting
P.O. Box 1475
Baltimore, Maryland 21203
Telephone: (301) 234-6409

Areas of Interest: Distribution System Management, Load Management

Activities include forecasting customer requirements of gas, electricity and steam services. Most experience has been in the Power Pooling Economics and Electric System Planning field.

ELECTRIC POWER RESEARCH INSTITUTE
Dr. William Blair
Project Manager, Electrical Systems Division
3412 Hillview Avenue
P. O. Box 10412
Palo Alto, California 94303
Telephone: (415) 493-4800

Areas of Interest: Load Management, Communication Systems, Distribution System Management, Revenue Requirement Finance

Activities include DOE/EPRI demonstration projects, especially demonstration of PLC, radio, and phone communication systems.

FLORIDA POWER CORPORATION
Russ Schoetker
Project Engineer
3201 34th Street S
P. O. Box 14042
St. Petersburg, Florida 33733
Telephone: (813) 866-5212

Areas of Interest: Distribution System Management

Activities include Distribution Automation economic justification study, Distribution Automation feasibility study, development of a Distribution SCADA system. The Distribution SCADA system is to be interfaced with and become a satellite to the FPC Energy Control Center, due on-line in the second quarter of 1979. Member of FPC Load Management Task Force. Experimenting with 1 way and 2 way systems being installed.

GENERAL ELECTRIC CORPORATION
Research and Development Center
Jack Easley
Senior Engineer, Power Distribution Systems Engineering
P. O. Box 43
Schnectady, New York 12345

Areas of Interest: Distribution System Management, Communication System, Control System, Reliability

Activities include a project to study the economic benefits for AMR and remote control utilizing PLC, several DAC studies with utilities.

GENERAL PUBLIC UTILITIES SERVICE CORPORATION

J. Loferski
Manager Telecommunications/Electronics
260 Cherry Hill Road
Parsippany, New Jersey 07054
Telephone: (201) 386-5700, Ext. 314

Areas of Interest: Distribution System Management,
Communication System

Activities include time-of-day metering, load research, measurement of noise and interference, capacitor control, 1000 point communications demonstration project. Chairman, Load Management/Distribution System Automation Committee of the Utilities Telecommunications Council.

JACKSON UTILITY

John Williams
Superintendent, Electrical Department
P. O. Box 63
Jackson, Tennessee 38301
Telephone: (910) 424-1911

Areas of Interest: Distribution System Management

Activities include study of impact of voltage control and reduction on major loads.

JET PROPULSION LABORATORY

Dr. Khosrow Bahrami
Technical Staff, DAC Team
4800 Oak Grove Drive
Pasadena, California 91103
Telephone: (213) 577-9126 or (FTS) 792-9126

Activities include studies in the area of automation and control of electric utility distribution systems; investigation of the control needs of future electric distribution systems; the impact of dispersed storage and dispersed generation on the distribution system; related digital computer and communication applications; studies in the area of cogeneration (i.e., concurrent generation of heat and electricity), where a real life application to an existing oil refinery was studied and conceptual design for waste heat bottoming cycles and topping cycles were developed and costing basis was established; design and development of distributed solar thermal generators.

JET PROPULSION LABORATORY

Ralph Caldwell

Project Manager, Distribution Automation and Control (DAC)

4800 Oak Grove Drive

Pasadena, California 91103

Telephone: (213) 577-9162 or (FTS) 792-9162

Areas of Interest: All

Activities include analysis of communication and control needs for future distribution systems. While Principal Electrical Engineer at Burbank PSD: "Development of Design Criteria for Citywide Electric Load Management and Control Systems" (for the APPA) and "Utility Controlled Management of Industrial Customer's Electrical Loads," presented at WATTEC, February, 1978. Member "Load Management Task Force" of IEEE.

JET PROPULSION LABORATORY

Dr. Robert R. Ferber

Technical Staff, Section 311

4800 Oak Grove Drive

Pasadena, California 91103

Telephone: (213) 577-9396 or (FTS) 792-9

Areas of Interest: Dispersed Storage, Communication System,
Reliability, Dispersed Generation

Activities include chairing of session on Unconventional Energy Resources. Over 50 energy technology papers and publications. Editor, Nuclear Plant Safety (book) IEEE, 1971; Editor, Transactions of the Ninth World Energy Conference, 1975. Requirements Definition Task Manager for the Small Power Systems Application Project (Solar Thermal Power).

JET PROPULSION LABORATORY

Dr. Elliott Framan

Utility Systems Manager, Office of Energy and Technology Applications

4800 Oak Grove Drive

Pasadena, California 91103

Telephone: (213) 577-9265 or (FTS) 792-9265

JET PROPULSION LABORATORY

Kengo Kawano

Project Analysis and Engineering Manager - DAC

4800 Oak Grove Drive

Pasadena, California 91103

Telephone: (213) 577-9063 or (FTS) 792-9063

Areas of Interest: All

Activities include current activities in DAC Requirements Analysis and Data Base generation. Previously involved with space flight command and control center design and implementation. Included in activity was data acquisition, computer systems, and display systems.

MASSACHUSETTS INSTITUTE OF TECHNOLOGY

Dr. Fred Schweppe

Professor of Electric Power Systems Laboratory, Utility Systems Program
Energy Laboratory Room 10-176
77 Massachusetts Avenue Tenn.
Cambridge, Massachusetts 02139
Telephone: (617) 253-4640

Areas of Interest: Control System, Reliability, Revenue Requirement
Finance, Miscellaneous, Long Range Future Dis-
tribution System Control and Design Scenarios

Activities include "Homeostatic Utility Control." Chaired session on
DAC Control Hierarchy.

McGRAW EDISON COMPANY

Bob Owen (Participant); Robert M. Webler (Continuing Contact)
Power Systems Division
P.O. Box 440
Canonsburg, Pennsylvania 15317
Telephone: (412) 873-2294

Areas of Interest: Distribution System Management, Reliability

Activities include a study to quantify the noise changes as a function
of the system characteristics such as capacity or banks, study of
communications reliability.

NEW ENGLAND POWER SERVICE COMPANY

Harold Kitching
Distribution Development Engineer, TWACS Program Manager
20 Turnpike Road
Westborough, Massachusetts 01581
Telephone: (617) 366-9011, Ext. 3014

Areas of Interest: Distribution System Management, Load Management,
Communication System

Activities include TWACS preproduction prototype tests, assessment of
the economic benefits of load management, studies of 2-way automatic
communication and control. Chaired session on Distribution System
Management. "New England Utility Uses Voltage, Current Waves for Load
Control," T&D, Sept. 1977.

NIAGARA MOHAWK POWER COMPANY
Dr. Roosevelt A. Fernandez
Research Engineer
Research & Development
Bldg. C-3, 300 Erie Blvd. West
Syracuse, New York 13202
Telephone: (315) 474-1511, Ext. 1063

Areas of Interest: Load Management, Emergency State Control,
Communication System, Reliability, Distribution
System Management, Dispersed Generation,
Control System

Activities include "Optimum Peak-Shaving Mix," "Peak-Shaving on the Electric Utility Grid Using Fuel Cells." A member of the EPRI Power System Planning and Operations Task Force. Associated with advanced generation and power system planning projects. . Emphasis on interface concepts for dispersed generation and storage including analysis of power systems impacts. Initiated projects involving transformer diagnostic maintenance and improved utilization of generation, transmission and distribution facilities. Installation of a 4.5 MW Fuel Cell Demonstration, installation of load management equipment at the Olympic Village, BEST facility to be completed in 1980, integration of electric and gas grid and renewable resources.

NIAGARA MOHAWK POWER COMPANY
Frederick A. Rushden
Research Engineer
Research & Development
Bldg. C-3, 300 Erie Blvd. West
Syracuse, New York 13202
Telephone: (315) 474-1511, Ext. 7202

Areas of Interest: Distribution System Management, Load Management,
Communication System

Activities include present activity in developing advanced methods of reducing substation transformer noise and lightning damage to distribution circuits, as well as developing a system assessment of distribution automation concepts. Currently, the major activity is in the assessment and development of a cost-effective, comprehensive automated distribution system. To this end, am conceptually designing and costing out various system concepts, assessing the financial impacts, and managing an experimental evaluation program. Participated with DOE and G.E. in PLC type communications system study, "Utility Responsibility for Load Management", IEEE Electro 77. "Probe-A Feasibility Demonstration of Substation and Distribution Automation", American Power Conference 1977.

NORTHERN STATES POWER
Dan Nordell
Supervising Research Engineer
414 Nicollet Mall
Minneapolis, Minnesota 55401
Telephone: (612) 330-5822

Areas of Interest: Load Management, Communication System, Dispersed
Generation, Dispersed Storage

Activities include IEEE PAS Substation Grounding Minnesota Power System Conference; Plane Dispersion Modeling. Chairman of NSP Automatic Meter Reading Committee. Responsible for NSP Development and Load Management and metering technology. Direct experience with the application of microprocessor technology to data retrieval and communications problems. Installation of power line carrier and evaluation of ripple control at Minnesota Power and overlapping with NSP service area. Demonstration of a variety of "controllable loads" for potential load management use. NSP is demonstrating a variety of customer thermal storage for space heating concepts and is demonstrating a small residential windmill. Parallel installation of AS&E and Westinghouse carrier systems for evaluation at NSP. Field testing of ATC equipment in cooperation with Honeywell to start late in 1978.

OAK RIDGE NATIONAL LABORATORY
Mike Kuliasha
Research Staff
P.O. Box Y
Oak Ridge, Tennessee 37830
Telephone: (615) 574-0330 or (FTS) 624-0330

Areas of Interest: Load Management, Dispersed Generation

Activities include principal work on Load Management. Currently working on assessment methodology and load management demonstration. "Impact of Thermal Storage on Electric Distribution System" paper to Summer T&D IEEE Conference.

OAK RIDGE NATIONAL LABORATORY
Hugh Long
Program Manager
P.O. Box X
Oak Ridge, Tennessee 37830
Telephone: (615) 574-5222 or (FTS) 624-5222

Areas of Interest: Load Management, Distribution System Management,
Dispersed Storage

Activities include telecommunications project with Omaha Public Power, planning for large scale DSM demonstrations on the TVA distribution system, several thermal storage projects. Load Management Project Administration and Management.

OAK RIDGE NATIONAL LABORATORY

John Stoval
Research Staff
P.O. Box X
Oak Ridge, Tennessee 37830
Telephone: (615) 574-5198 or (FTS) 624-5198

Areas of Interest: Emergency State Control, Communication System

OMAHA PUBLIC POWER DISTRICT

Gerald J. Krause
Manager, Customer Requirements and Rates
1623 Harvey Street
Omaha, Nebraska 68102
Telephone: (402) 536-4068

Areas of Interest: Load Management, Communication System

Activities include demonstration of telephone line-based system for metering and control (DARCO).

ONTARIO HYDRO

Robert L. Hajas
Residential/Commercial Load
Superintendent
700 University Avenue
Ontario, M5G1X6, Canada
Telephone: (416) 592-3820

Areas of Interest: Load Management, Distribution System Management, Communication System

Activities include "Role for Load Management in Ontario," July, 1978, Energy Conservation Division Report #ECD-78-6, G.H. West and R.L. Hajas. Detailed functional specification of customer load control and field trial. Ontario Hydro is doing two projects on load management, communication and direct load control; one involves telephone with AM radio and the other is a PLC type. Activities include a door-to-door customer survey soliciting opinion and signing up demonstration volunteers. Ontario Hydro, with Scarborough PUC, is implementing a demonstration of capabilities for a distribution automation system with two 27.6/16 kV feeders in Toronto in the AMEU Distribution Automation Project.

ONTARIO HYDRO

Lawrence V. McCall
Supervising Distribution Design Engineer
700 University Avenue
Toronto, Ontario, M5G1X6, Canada
Telephone: (436) 592-4781

Areas of Interest: Load Management, Emergency State Control, Communication System, Distribution System Management, Control System

Activities include CEA Research Report 76-13, "Quantifying the Benefits of Distribution System Automation." Vice Chairman of IEEE/PES Switchgear Committee. Completion of the first draft and a functional spec. for an automation project.

PACIFIC GAS & ELECTRIC COMPANY

Orville L. Hill
Senior Electrical Engineer
Room 1853, 77 Beale Street
San Francisco, California 94106
Telephone: (415) 781-4211, Ext. 2148

Areas of Interest: Communication System, Control System, Dispersed Storage, Load Management

Activities include participation in telephone line communication system for data management on PG&E System. Chaired session on impacts on System Design.

PHILADELPHIA ELECTRIC COMPANY

John B. Blose
Senior Engineer, Research and Testing Division
2301 Market Street
Philadelphia, Pennsylvania 19101
Telephone: (215) 841-4866

Areas of Interest: Load Management, Emergency State Control, Dispersed Storage, Communication System, Distribution System Management, Dispersed Generation, Control System

Activities include AMRAC test installation which is in the second year of Phase II, developing control system based on "on-hook" or "off-hook" use of telephone lines. Chaired session on communications alternatives. "Automatic Meter Reading at Philadelphia Electric Company with the General Electric Company Phase II AMRAC Equipment," by J.B. Blose, EEI/AEIC Meter and Services Committee, Philadelphia, 9/21/76; "Automatic Meter Reading at Philadelphia Electric Company-A Progress Report," by J.B. Blose, Pennsylvania Elec. Assoc., Eng. Sec. Johnson, Pa., 10/17/75; "Automatic Meter Reading-Trial by Philadelphia Electric Company," J.B. Blose, Penn. Elec. Assoc. Comm. Committee, Pittsburgh, PA., 2/1/74.

PUBLIC SERVICE OF NEW MEXICO
Evans Spanos
Load Management Coordinator
Public Service Bldg
414 Silver Avenue, S.W., P.O. Box 2269
Albuquerque, New Mexico 87103
Telephone: (505) 842-2700

Area of Interest: Load Management

SAN DIEGO GAS & ELECTRIC
James A. Hunter
Manager of Marketing Programs
P.O. Box 1831
San Diego, California 92112
Telephone: (714) 232-4252

Areas of Interest: Load Management, Communication System, Revenue Requirement Finance, misc. policy and development

Chaired session on Load Management. Active in formative years of Load Management.

SOUTHERN MARYLAND ELECTRIC COOP., INC.
Richard J. McCoy
Chief Engineer
Hughesville, Maryland 20637
Telephone: (301) 274-3111

Areas of Interest: Load Management, Revenue Requirement Finance

Activities include writing specifications for load management systems and equipment.

UNION ELECTRIC COMPANY
James E. Healey
Manager T&D Operating Department
721 South 5th Street, P.O. Box 149
St. Louis, Missouri 63166
Telephone: (314) 621-3222, Ext. 2141

Areas of Interest: Distribution System Management, Communication System

Activities include installation of supervisory control systems in distribution substation, development of a customer master file system providing a concise report when an outage is reported.

UNITED STATES DEPARTMENT OF ENERGY
Kenneth W. Klein
Technical Assistant to the Director
Electric Energy Systems Division
20 Massachusetts Avenue
Washington, D.C. 20545
Telephone: (202) 376-4596

Areas of Interest: Emergency State Control, Revenue Requirement Finance

Activities include several in distribution economics; transformer losses evaluation; R&D on electric energy systems.

UNITED STATES DEPARTMENT OF ENERGY
David Mohre
Branch Manager, Load Management Branch
Electric Energy Systems Division
20 Massachusetts Avenue
Washington, D.C. 20545
Telephone: (202) 376-4732

Areas of Interest: All

UNITED STATES DEPARTMENT OF ENERGY
Phil Overholt
Assistant Program Manager
Electric Energy Systems Division
20 Massachusetts Avenue
Washington, D.C. 20545
Telephone: (202) 376-4732

Areas of Interest: All

Activities include investigating the feasibility of using the distribution feeder as a communication path (mathematical modeling) noise analysis on the distribution system.

UNIVERSITY OF TENNESSEE
Dr. Tom Reddoch
Associate Professor, Department of Electrical Engineering
Knoxville, Tennessee 37916
Telephone: (615) 974-5028 or (FTS) 855-5028

Areas of Interest: Dispersed Storage, Load Management, Dispersed Generation, Revenue Requirement Finance

Activities include Specialist in application and development of utility interface for dispersed wind generators. Active in DOE demonstration projects. Chaired session on Integration of new sources.

WESTINGHOUSE ELECTRIC COMPANY
David Berkowitz
T&D Systems Engineer
700 Braddock Avenue
East Pittsburgh, Pennsylvania 15239
Telephone: (412) 256-2609

Areas of Interest: Load Management, Communication System, Distribution System Management, Reliability

Senior Engineer for Transmission & Distribution Systems Engineering. Responsibilities are primarily in the evaluation of new products for the Transmission & Distribution Products Division. Has developed several economic application techniques for the evaluation of load control and energy storage technologies, and has computerized several of them for use by the Raleigh Meter Division. Paper - "A Look at Load Management for Non-Generating Utilities-Update"; "Both Generating & Non-Generating Utilities Can Benefit from the Use of the Distribution Line Carrier System" (Berkowitz, S.A. Jordan, D.L. Nickel); "The Value of the Distribution Line Carrier System for Load Management" (Berkowitz, S.A. Jordan, D.L. Nickel); "The Distribution Line Carrier System - Versatile & Economical" (Berkowitz, S.A. Jordan, D.L. Nickel).

WISCONSIN ELECTRIC POWER
Glen Lokken
Superintendent, Special Studies
231 West Michigan
Milwaukee, Wisconsin 53201
Telephone: (414) 277-2560

Areas of Interest: Load Management, Emergency State Control, Communication System, Reliability, Distribution System Management, Control System

Activities include implementation of full scale water heater control program including a 2-way communication system. "WE Takes First Step Towards ADS," T&D Sept. 1977. Chaired session on Economic and Institutional Issues.

APPENDIX C

AGENDA - DAC WORKING GROUP MEETING

APPENDIX C

AGENDA - DAC WORKING GROUP MEETING

For reference purposes for those readers who did not attend the DAC Working Group meeting, the agenda is given here to illustrate the activities of the meeting.

Sunday, November 19, 1978

Evening:

Orientation of Working Session Discussion Chairmen
With JPL and DOE Staff

Monday, November 20, 1978 (Introduction and Overview)

Morning:

- Welcome R. Caldwell, K. Kawano - JPL
- DOE Overview of DAC D. Mohre - DOE
- EPRI Overview of DAC W. Blair - EPRI
- "Distribution System
in the Year 2000,
Homeostatic Utility
Control F. Schweppe - MIT

-Break-

- DAC Working Group
Goals, Objectives
and Format R. Caldwell - JPL
- Panel Discussion -
Introduction of
Technical Motivations
 - Load Management J. Hunter - SDG&E
 - Distribution of
System Management H. Kitching - NEPS
 - Unconventional
Energy Resources R. Ferber - JPL
 - Emergency State
Control W. Prince - BG&E

Afternoon:

- Working Session Discussions of Each of the Four
Technical Motivations (Load Management and Uncon-
ventional Energy Resources Management were combined)

-Break-

- Plenary Session With Chairmen's Reports, Discussion and Distribution of Questionnaires

Evening:

- Dinner
- Dinner Presentation on Solar Energy R. Ferber - JPL
- Informal Discussions

Tuesday, November 21, 1978 (The Six Areas of Issues)

Morning:

- Areas of Issues Working Sessions
 - Functional Requirements K. Klein - DOE
 - Economic and Institutional Issues G. Lokken - Wis. Elec.

-Break-

- Areas of Issues Working Sessions
 - Impact on System Design O. Hill - PG&E
 - DAC Control Hierarchy F. Schweppe-MIT

Afternoon:

- Areas of Issues Working Sessions
 - Impact on System Design (cont'd)
 - DAC Control Hierarchy (cont'd)

-Break-

- Areas of Issues Working Sessions
 - Communication Alternatives J. Blose - Phil. Elec.
 - New Source Integration T. Reddoch - U. of Tenn.
- Distribution and Completion of Questionnaires

Evening:

- Dinner
- Dinner Presentation on DAC Functional Requirements K. Klein - DOE
- Informal Discussions

Wednesday, November 22, 1978

- Summary Session
 - Recap Results of Working Sessions and Relate to Working Group Objectives
- Luncheon
- Executive Session (Working Session chairmen only)
- Adjournment

APPENDIX D

PRE-MEETING MATERIALS (FACT SHEETS)

The Fact Sheets included in this appendix were taken directly from the DAC Working Group Information Booklet, which was used as a reference document during the meeting. The Fact Sheets provide background and elucidate the starting point of the Working Session discussions. The Fact Sheets are for reference purposes only and do not represent a comprehensive or formal statement of definition or opinion.

LOAD MANAGEMENT

DAC Workshop Fact Sheet #1

DEFINITION

The definition of Load Management is still being discussed in the Electric Industry. However, as a workshop definition, the following excerpt from the DOE Program Plan DOE/ET 0004 will be used:

"Load Management is the systems concept of altering the real or apparent pattern of electricity use in order to (1) improve system efficiency, (2) shift fuel dependency from limited to more abundant energy resources, (3) reduce reserve requirements of generation and transmission capacity, and (4) improve reliability of service to essential loads".

Load Management, in its most general application, requires that control capabilities be available to the utility, in order to optimize the supply-load combination. Load Management is not simply peak shaving, but includes load shaping, emergency load shedding, energy management, management of customer and utility energy storage. Specific applications of Load Management are found in customer-owned systems and in special rates adopted by utilities.

BACKGROUND INFORMATION

Present Activities:

1. DOE thermal energy storage test program.
2. Continuation by Detroit Edison of their radio-based load control system.
3. A total of 41 known load control projects in the U.S. Use of load controls continues to be relatively common in Europe.
4. IEEE Load Management Task Force activities.
5. Five Joint DOE/EPRI feasibility tests of two-way communication systems which can lead to load control and distribution system automation.
6. Industrial and customer demand control and energy management systems, e.g., Johnson Space Center HVAC control, Lockheed California Energy Management Systems, etc.
7. Continuation of proposals for, and adoption of, new rates designed to encourage shifts in use patterns (across the U.S.).

Publications:

1. "Program Plan for Research, Development and Demonstration of Load Management on the Electric Power System", U. S. Dept. of Energy, Division of Electric Energy Systems, Jan. 1978 (DOE/ET-0004).

2. "Survey of Utility Load Management and Energy Conservation Projects, Part 1", Energy Utilization Systems, Inc., (DOE/EPRI funded).
3. Electric Utility Rate Design Study "Rate Design and Load Control", a report to the National Association of Regulatory Utility Commissioners, November 1977.

Comment:

Most activities to date in the Load Management area have concentrated on specific problem areas and subsystems. Total implementation of the Load Management concept requires development of viable dispersed storage and generator units and other components or tools for Load Management; however, many of the "tools" required for implementation of much of the Load Management concept are presently available. Overall systems integration work is required.

EXAMPLES OF KEY ISSUES AND UNCERTAINTIES

- The possible legal problems arising from severe load control actions by utilities (inadvertant actions, product loss).
- The control hierarchy within Load Management which functions dominate? At all times? Dependent on type of distribution system and extent of load control, dispersed generation, dispersed storage?)
- The need for communications systems capable of control, status and metering data transmission as a result of Load Management implementation on a wide scale (who owns? What type? What security levels?)
- The speed of response, number of transmissions of data per time period, accuracy, security level, etc., requirements of the communications and control system.
- The changes in Distribution System design required due to possible increases in maximum loading as a result of Load Management demand deferring actions, etc. (Effects on system design due to shifts in load profiles.)
- The control and communications requirements due to the connection of small, dispersed generation and storage units on the Distribution System (black start, monitoring of availability and capacity, etc.).

DISTRIBUTION SYSTEM MANAGEMENT

DAC Workshop Fact Sheet #2

DEFINITION

Distribution System Management (DSM) is any method or methods used to remotely and/or automatically control and monitor 'Distribution System' devices and elements to achieve optimal operation of the distribution system in terms of economy and efficiency. DSM includes actions ranging from on line control to data gathering, enabling calculations for economical transformer replacement for example. This definition, in its broadest interpretation, includes methods based on very simple control devices not integrated with overall system control, as well as sophisticated, integrated systems capable of reconfiguration of portions of the distribution system, tighter control of voltage regulation and var flows, meter reading, telemetry in general and status reporting. The span and depth of control are dependent on the objectives. The dominant technical considerations may be in areas of communications and control for Distribution System Management, but actual applications of the full capabilities for management may require significant changes in methods and costs related to the power equipment and systems.

BACKGROUND INFORMATION

Present Activities:

1. Various test programs and commercial installations where selected distribution system components are controlled (e.g. shunt capacitor switching), and where remote meter reading systems are being evaluated.
2. Control and monitoring of the distribution system's major elements; subtransmission devices, distributing stations devices and feeders is presently done by many utilities.
3. Five (5) Joint DOE/EPRI feasibility tests of two-way communication systems which can lead to Distribution System Management.
4. Some of the activities within IEEE Committees relate to aspects of DSM. "Automatic and Supervisory Subcommittee" and "Power Systems Communications Committee".

Publications:

1. "Program Plan for Research, Development and Demonstration of Load Management on the Electric Power System", Jan. 1978, U.S. Dept. of Energy, Div. of Electric Energy System (DOE/ET-0004).
2. Beaty, W., "Automated Distribution; Improves Systems Operations and Reliability Electric World, July 1977.

Comment:

Most activities to date have concentrated on specific problem areas and sub-systems, although there have been systems developed by manufacturers that may satisfy much of the communication control requirement. More efforts are needed toward an overall integration of the possible DSM functions using the full DAC capability. It is also possible that some functions such as var control or system loss reduction would benefit from examining their interface with the bulk supply and sub-transmission systems. Power System devices, such as reclosers, sectionalizers, remote switching devices, etc. may require significant cost reduction efforts if substantial amounts of distribution system reconfiguration actions are to occur in the future. A different "class" of power devices may be indicated. The dominance of radial distribution systems and the problems of coordinating protective devices are specific areas requiring attention beyond the communication and control considerations.

EXAMPLES OF KEY ISSUES AND UNCERTAINTIES

- Can extensive "DSM" be cost effective? What portions of the DSM concept have the best cost/benefit ratios? What are the most troublesome constraints on full DSM implementation? (Costs of additional power equipment? Costs of control system? etc.)
- The control hierarchy within DSM--what functions dominate? At what levels are decisions made and under what logic?
- The need for communications systems capable of control status and metering data transmission as a result of DSM implementation on a wide scale. (Amounts of information transmission, response time requirements, security of system, accuracy and dependability, etc.?) What kind of system? A combination of systems?
- The changes in Distribution System design required due to the full implementation of DSM concepts.
- The specific performance characteristics required of DAC systems (communication and control elements combined).

EMERGENCY STATE CONTROL

DAC Workshop Fact Sheet #3

DEFINITION

Emergency State Control (ESC) is the ability of the DAC system to remotely and/or automatically provide: emergency state detection, pre-emptive action in anticipation of the emergency state, corrective and restoration control. Present Supervisory Control Systems do not provide a method of accomplishing ESC at the distribution level. Therefore, discussion here should consider DAC providing control:

1. To the depth, or to the level of discrete elements contemplated for future systems;
2. For all aspects of ESC, e.g., anticipation of certain kinds of emergency states such as imminent failure due to insulation breakdown;
3. With dispersed generation and storage generally connected to the distribution system.

Further, the full application of ESC will require methods for response to two kinds of emergency conditions:

1. Loss of, or imminent loss of, Bulk Supply facilities (load shedding, start-up or increase in output from dispersed storage and generation), and
2. Loss of, or imminent loss of, portions of the distributed system.

The ESC systems which may evolve will have a strong relationship to the Distribution System Management systems, as well as to Load Management and Unconventional Energy resources.

There are implications on power equipment design, application and costs as well as on communications and control technology.

BACKGROUND INFORMATION

Present Activities:

1. Five (5) DOE/EPRI feasibility test of two-way communications systems which can lead to Emergency State Control.
2. Some of the activities within IEEE Committees, such as "Working Group 72.3 of the Automatic and Supervisory Subcommittee", and "Working Group on Distribution System Reliability of the Distribution Subcommittee".
3. Control and monitoring of selected elements of the Distribution System as presently done by utilities with Supervisory Control System.

Publications:

1. Papers, Proceedings and articles dealing with Load Management, Distribution System Reliability, and Distribution Automation often contain information in the area of Emergency State Control.

2. Beaty, W., "Automated Distribution; Improves System Operation and Reliability", Electrical World, July 1977.
3. Schweppe, F. C., "Power Systems 2000; Hierarchical Control Strategies", IEEE Spectrum, July 1978.
4. Fink, L. H., "System Engineering for Power", Program Report DOE/ET-0012/1.

Comment:

Emergency State Control at the distribution system level has been limited largely to the detection of faults and attempted automatic service restorations in the absence of a communication system. With the added dimension of load control capability and information retrieval and processing enabled by a DAC system, emergency state control assumes a greater significance. The anticipation of the emergency state may be considered in two (2) broad areas: 1) overload and 2) insulation breakdown. Overall system integration, including interface with Bulk Supply System Control is needed. For smaller discrete system elements to be controlled, a different "class" of power devices may be required. For the implementation of the full "ESC" concept, new types of sensors (e.g., on-line corona detectors) would be required. A probable future configuration for distribution systems with "ESC" features will include: fully automated responses to emergency conditions where economics and other power system considerations allow; remote control capabilities with an operator interface arranged for immediate display of alternatives to emergency and the probable adverse effects for each alternative; informational systems available to trouble crews, dispatchers, etc., showing location of problem, extent of system affected, indication of ways to isolate fault and restore service to as much load as possible, and clear indication of essential loads including life-support systems. Thus, the full ESC system will include human components.

Another dimension to ESC is the speed of response of the control system. Faults are typically cleared in a matter of cycles but overload conditions, depending on the severity of the situation, may allow many minutes for action. The areas of voltage and frequency control may also be considered for stability and overload conditions during system disturbances as an additional ESC function for a DAC system.

EXAMPLES OF KEY ISSUES AND UNCERTAINTIES

- The cost effectiveness of ESC relative to other ways of responding to supply deficiencies, e.g., expanded interconnections, bulk supply storage systems, etc.
- The impact of ESC on the distribution system characteristics of economy, reliability, flexibility, capability, safety.
- The specific performance characteristics required of the DAC System.
- The methods of retaining present levels (or desired levels) of reliability with the increased opportunities for malfunctions which may result from a significant increase in devices and control actions.
- The effects on manual restoration times if the ESC system and the power system suffer simultaneous failures (earthquake for example).

The magnitudes of effects desired, and the required actions of DAC systems under loss of supply conditions.

UNCONVENTIONAL ENERGY RESOURCES

DAC Workshop Fact Sheet #4

DEFINITION

Unconventional Energy Resources (UER) are energy storage or generating systems using renewable resources or devices designed at present to complement conventional power generation (fossil and nuclear steam turbine, hydro, gas turbine) methods. A common characteristic of these sources is that they are small in unit size compared to traditional central station generation. Examples of UER are fuel cells, solar photovoltaic systems, wind generators, thermal storage, geothermal generation, battery storage, cogeneration, advanced coal technology and solar thermal generation.

While there already are a number of "UER" units of various kinds installed in the United States, the connection of significant numbers of such devices on a distribution system leads to a need for a DAC system.

These resources will generally be dispersed throughout the distribution system, with sites selected due to availability of waste heat, need for waste heat, presence of favorable wind conditions, access to roof or other unused space, etc. Thus, the definition of UER for purposes of DAC discussions implies remote control and remote monitoring of status and capacity of such units.

BACKGROUND INFORMATION

Present Activities:

Solar Thermal: Several solar thermal demonstration projects are underway. Several schemes including central receiver stations with steam Rankine and Brayton, as well as distributed collector schemes are being considered. Initially the power output levels of 1-100 MW are planned. A 10 MW DOE sponsored plant is under development. It will be located near Barstow, California.

Photovoltaic: Photovoltaic systems have been developed. (EPRI, Sandia, JPL, etc.) For example, a 25 kW unit is operating in Nebraska. A 260 MW system is under development (see Reference 1). A 250 kW unit is planned by Mississippi County Community College Project. However, there are still some technical (e.g., array degradation), and cost problems.

Fuel Cell: First generation fuel cells use hydrogen. United Technology Corp, is developing a 4.8 MW size demonstration unit to be incorporated into a utility (e.g., Con Ed, N.Y.). This unit will be operational in 1979. Several utilities (e.g., SCE) are planned to incorporate fuel cells (size 26 MW) in their system. Research and development in this area is continuing, particularly in the development of fuel reformers and in fuel processing (see Pub. 2).

Wind Generator: Several small and medium size wind generation units are in operation and/or development (e.g., at NASA-LeRC; Pub. 3).

Batteries: Storage batteries is a very attractive area and is actively pursued (e.g., DOE programs in Electric Storage). The potential of batteries for utility peak load leveling is excellent (see Pub. 4).

Cogeneration: There are substantial cogeneration opportunities in certain industries (e.g., petroleum refinery, cement, paper industries) (see Pub. 5) These include power ranges of few kW to 100 MW or higher. Many utilities are already involved in cogeneration (e.g., SCE, SDG & E with Navy, PG&E).

Publications:

1. Final Report on "A Conceptual Design of a Photovoltaic Control Station Power Plant", by Bechtel Corp., July 1976.
2. Lawrence, L.R., et al., "The ERDA Fuel Cell Program", IEEE Power Engineering Society Papers, Energy Development IV, 1978.
3. "Plans and Status of NASA-Lewis Research Center Wind Energy Project", by R. Puthoff, J. Savino and W. Johnson, Energy Development IV, 1978.
4. Rosser, A. B., "Large Lead-Acid Batteries as Viable Utility Peak Load Leveling Alternative", Energy IV, 1978.
5. "Potential for Cogeneration of Heat and Electricity in California Industry--Phase I, Final Report", JPL 78-42, 1978.

Comments:

The general status of a number of UER's was listed above. While much effort has been expended in developing the units, more attention must be directed at problems and system needs if such units are to be installed in significant numbers on distribution systems. Some areas of interest might be: How should their operation be managed? How should they be treated under "economic dispatch" criteria? How will capacities be monitored and anticipated for scheduling purposes? The general area of Power Management must be considered in light of these new resources.

EXAMPLES OF KEY ISSUES AND UNCERTAINTIES

- What will be the unit sizes, and will size dictate different levels of control?
 - Will types of fuel or other input energy require control and monitoring? (For fuel cells and cogeneration, will there be alternate fuels implying fuel transfer under load, etc.?)
 - Where will UER units be located? (Are there implications for special consideration of DAC requirements due to location of units?)
 - The nature of the UER and its designation as a "firm source" or "energy source". (What are the DAC requirements related to availability, capacity and status?)
- The short-time versus long-time capabilities of UER. (For storage systems, if short-time peaking use can be based on a higher capacity, how does this impact DAC requirements?)
- When will UER units be available and installed?
 - Will environmental constraints lead to special DAC considerations? (NOX dispatch conditions, fuel transfers, etc.)

ECONOMIC AND INSTITUTIONAL ISSUES

DAC Workshop Fact Sheet #5

DEFINITION

Economic and Institutional Issues can be categorized as either constraints or opportunities, although in many cases they may be simply considered and found to have no particular effect on the conclusions or decisions made within the utility industry. The emphasis for the DAC Workshop will be on those Economic and Institutional Issues that do either serve as constraints or provide opportunities for desired changes in utility systems. Some examples of Economic and Institutional Issues are:

- Economies of scale vs. improvements in reliability, etc.
- Availability of Capital Funds
- Availability of operating funds
- Most effective use of financial resources
- Conflicts between actual costs to serve and tariffs designed under a social concerns or other such criteria
- Regulatory constraints on innovative arrangements for unconventional energy resources.
- Assessment of priority of service to customers and customer classes

The DAC systems of the future will require the elimination of constraints, and may require use of economic and institutional innovation.

BACKGROUND INFORMATION

Present Activities:

Economic and Institutional Issues routinely confront the electric industry. The existence of franchises and aspects of interstate commerce make institutional issues a key part of the electric utility's methods of doing business. The relationship of costs of alternative systems, generation units, changes in systems etc. to the tariffs and possible changes in tariffs is continually subject to examination.

The emphasis on standardization of components and methods provides an example of a partial solution to an economic issue. A concern that costs for too aggressive a program towards innovation might be disallowed in the tariff based revenue is an example of a constraint which arises from the institutional arrangements.

Comments:

The Workshop discussions on Economic and Institutional Issues provides an opportunity to perform an overview of these issues as they apply to the four areas of Technical Motivation: Load Management, Distribution System Management, Emergency State Control, and Unconventional Energy Resources. The combination of systems and procedures for the solution of each Technical Motivation may, when examined in total, give rise to new Economic and Institutional Issues, or to changes in the relative significance of these issues.

EXAMPLES OF KEY ISSUES AND UNCERTAINTIES

- The future relationship of the utility to the customer as full implementation of the four Technical Motivations is approached (tariff design, impacts on revenue requirements and cost-to-serve allocations, legal ramifications of inadvertent actions related to load control and accessing of customer owned storage and cogeneration).
- The need for Code modifications to reduce costs for special installations (utility operation and maintenance of facilities on customer premises).
- The priority of supply allocation from a mix of central station generation, dispersed utility-owned generation and storage, and customer-owned generation and storage.
- The allocation of costs for energy and capacity from the supply mix above.
- The priority of use of communications systems which are part of a DAC system, but not owned by the electric utility.

PRE-MEETING REFERENCE MATERIAL

DAC CONTROL HIERARCHY

DAC Workshop Fact Sheet #6

DAC Control Hierarchy is a determination of the priority for access and control by the DAC system among the four technical motivations should a conflict for access arise. The DAC control hierarchy would be interfaced with the system benefits. As an example, if actions calling for load control simultaneously with service restoration following a fault were received at a distribution substation, the service restoration action would prevail. Some local grouping of control functions could minimize such conflicts.

Another aspect of control hierarchy is the distributed nature of processing of information desirable to minimize competition for vertical communication links.

For the Workshop, Control Hierarchy will be discussed in several aspects. There is a hierarchy of control systems and subsystems which can be viewed as an arrangement based on authority and the special right to override or interrupt the actions of other systems. This is analogous to the management supervision - workers relationship in an organization.

Another aspect of the DAC Control Hierarchy involves location of functions and the physical relationships of elements of the hierarchy to "control centers" and human operators. Again, the parallel to arrangements made for siting management, supervision and workers can be drawn. There are arrangements that can improve the performance of the total hierarchy.

Yet another aspect of the DAC Control Hierarchy involves the frequency of actions, number of points controlled or monitored, and the total information processing requirements. For large numbers of repetitive actions, an organization will gather a large number of workers under one supervisor, and look for ways to streamline the repetitive actions and their sequence, whereas for infrequent actions of a special nature, supervision and even management may take a direct role.

The last aspect involves the creation of boundaries within which decisions can be made without reference to higher authority. The organizational parallel includes concepts such as standards of performance, management by exception (excursions, or attempted excursions beyond predetermined boundaries), specific delegation, etc.

BACKGROUND INFORMATION

Present Activities:

1. A Hierarchy of Control exists whether planned for or not. Within the distribution system, most hierarchies of control are independent of the bulk system control systems hierarchy. Current activities in load control experiments, once an interface is accomplished with the supply control system, are leading to the incorporation of some portions of distribution control into the Bulk System Control Hierarchy. The special form of load control called load shedding is another example of the partial inclusion of distribution system control in the Bulk System Control Hierarchy.

Publications:

1. Schweppe, F. C. "Power Systems 2000: Hierarchical Control Strategies," IEEE spectrum 7-78.

Comments:

Consideration of all the aspects of Control Hierarchy while also viewing the control requirements for satisfaction of the four Technical Motivations will probably lead to arrangements of control systems differing from those resulting from totally independent consideration. Included in a consideration of DAC Control Hierarchy are the following questions:

Can we consider one of the Technical Motivations to be dominant at all times? Will the dominant position change with time? How can we develop systems which can provide the flexibility to accommodate any real-life control hierarchy?

KEY ISSUES AND UNCERTAINTIES

- The interface with, and provisions for, the present systems control hierarchy.
- The search for commonalities of needs and solutions in aspects of control hierarchy for DAC, among the four Technical Motivations.
- The identification of boundaries within the hierarchy.
- The extrapolation of present and planned SCADA systems to satisfy DAC requirements.
- The use of load control systems in a manner consistent with other motivations eg, Emergency State Control.

COMMUNICATION ALTERNATIVES

DAC Workshop Fact Sheet #7

The DAC systems of the future will require that substantial amounts of information and control instructions be conveyed among centralized control facilities, dispersed remotes and even individual devices. This extreme dispersion of controlled devices and telemetry points has a significant impact on the methods to be used for conveying information. Also, the paths for information must be capable of bi-directional as well as unidirectional flow. Further impacting the selection of communication alternatives is the need for security of information flow, and the avoidance of interference with other systems. The alternatives presently being considered include:

- Radio
- Power Line Carrier
- Telephone, Communication Utility System
- Telephone, Power Utility Owned
- Microwave
- Satellite
- Fiber Optics
- Hybrid (any combination of more than one of the above)

BACKGROUND INFORMATION

Present Activities:

1. Five Joint DOE/EPRI test beds, directed at remote meter reading, but based on two-way communication systems.
2. Continuation by Detroit Edison of their radio-based load control system.

Publications:

1. "Survey of Utility Load Management and Energy Conservation Project, Part 1" Energy Utilization Systems Inc., (DOE/EPRI Funded).

Comments:

Most activities to date on the testing and development of new communication means have been related to a specific Technical Motivation, e.g., Load Management. Work is continuing on EMI research which will be applicable to the selection of communication alternatives. The applications of fiber optics may expand beyond present uses for electrical isolation and selected high volume data transmission. Consideration in selecting alternatives must also be given to the operations and maintenance needs of electric utilities, remembering that their business is based on the sale of electrical energy, not communications services, at least at this time.

KEY ISSUES AND UNCERTAINTIES

- The channel capacity, security levels, and accuracy requirements for the composite system derived for satisfaction of all four of the Technical Motivations.
- The value of ownership of the total communication path (can ways be found to assure power utilities of security when using facilities owned by others?)
- Spectrum management, relation of power utilities needs to others and the assignments of the spectrum.
- Interference with data transmission due to power system faults, lightning, other disturbances.
- The possibility that reliability and/or responses to emergencies may be adversely affected if power and control facilities are wed (simultaneous loss of power facilities and control facilities).
- The possible interference by the non-electric utility communications systems and data transmission with other communications systems.
- The consideration that applications may require one-way communication for every customer location, and two-way communication for some selected customers and for the distribution system elements (eliminate over-design).
- The possibility that one alternative may best satisfy all needs for all utilities; or a classification based on geographical configurations, control-point density, performance needs, etc.

IMPACT ON SYSTEM DESIGN

DAC Workshop Fact Sheet #8

System Design involves the selection and arrangement of components and their interconnection based on operating practices, economic evaluations of components and configurations, and criteria based largely on experience. New communication and control tools will allow for load patterns never before experienced, impacting economic component selection and configuration, but will also enable the monitoring of these load patterns to aid in future system design. Since the full use of DAC is likely to evolve for any one system over a number of years, the "Impact on System Design" discussions must be directed toward present and future power system designs and design philosophies as well as present and future DAC systems. Regardless of whether present or future systems or components are considered, a further task in System Design is to evaluate the impacts of any proposed changes on the following characteristics of the electric utility system:

- Economy
- Reliability
- Safety
- Flexibility
- Capability
- Suitability in the environment

BACKGROUND INFORMATION

Present Activities:

Almost every activity in power system design, construction and operation impacts the characteristics of the power system. Thus, the "Impact on System Design" is directly or indirectly considered in the decision making process, whether the process leads to new design, new standards or new procedures.

Comments:

The impacts on system design which may result from implementation of part of a Load Management concept, or from an addition to the Supervisory Control System, or from any specific, single purpose system addition, are routinely considered in the planning and design phase. However, when considering the entire spectrum of Load Management, Distribution System Management, Emergency State Control and Unconventional Energy Resources, the issue of "Impact on System Design" merits special and separate consideration. This special consideration is even more necessary since present and future components, methods and systems, some of which are related to all four Technical Motivations and many of which are not, are involved.

Whole new design and operating philosophies can be imagined when storage, generation, load control and distribution equipment control is available even down to the residential customer level. For example, equipment thermal loading limits restrictions may possibly be revised. Also more information will be available for operating decisions and design considerations.

The costs, benefits and effects on utility system characteristics must be viewed in total as well as on a per function basis. In other words, the tradeoffs among various approaches to implementing each of the four Technical Motivations must be considered, and that requires a broader system outlook.

EXAMPLES OF KEY ISSUES AND UNCERTAINTIES

- The changes in the maximum loadings of lines and equipment throughout the distribution system when all four Technical Motivations are implemented. (How is the "N-1" case defined or even recognized if, within the distribution system, there are sources, storage devices, shedable loads, alternate feeder configurations, etc.?)
- The identification of potential modifications to the power system which can satisfy more than one Motivation.
- The effects on the characteristics of the utility system caused by, or contemplated to be caused by, application of more than one of the Technical Motivations. (The effects might be different for the combination than for the individual applications).
- What configurations of future power systems are required for the maximum application of the four Technical Motivations? (to provide a spectrum for use in long range considerations, the spectrum spanning from present power systems to the postulated future systems).

PRE-MEETING REFERENCE MATERIAL

DAC FUNCTIONAL REQUIREMENTS

DAC Workshop Fact Sheet #9

The functional requirements for the future DAC systems will be determined by consideration of:

- The needs for systems satisfying the performance needs for each Technical Motivation.
- The present and future configurations of power and control systems without DAC systems.
- The present and future needs for information as mandated by forces outside the utility.

In the Workshop, discussions of the issue of "DAC Functional Requirements" will be directed at the composite requirements for the total DAC system rather than for one specific system developed in satisfaction of only one of the Technical Motivations. The commonalities and any examples of conflict regarding functional requirements should be discussed and identified

The functional requirements may be thought of in very general terms as specific objectives such as improving efficiency, reducing peaks, increasing reliability, etc. However, this way of expressing functional requirements is insufficient for purposes of identifying DAC system specifications.

Also, the general functional requirements can be identified by describing a specific effect desired, such as isolation of faults, synchronizing of dispersed generation, monitoring of transformer and line loadings, voltage regulation within limits which can be varied remotely, load control, automatic meter reading, etc. Again, this kind of description is too general for purposes of specifying DAC systems.

Functional requirements must ultimately be defined as to:

- purpose or type of function (status, command, telemetry)
- relationship to Technical Motivation
- relative importance to power system operation
- frequency of application (how often will function be used?)
- response time requirement (how quickly must function be accessed?)

BACKGROUND INFORMATION

Present Activities:

While not directed towards the establishment of functional requirements on a scale contemplated for the DAC System, the following projects may be of value in determining some of the functional requirements.

1. PROBE project of G.E.: The "Power Resource Optimization by Electronics" project of "General Electric Corporation" is involving Commonwealth Edison, Niagra Mohawk and Public Service Electric and Gas. Initiated in 1973, a research installation was established at a Commonwealth Edison's distribution substation. The objective is to access the economic and technical feasibility of automating a range of substation and distribution monitoring and control functions.
2. PDAC project of PG&E²: The "Primary Distribution Alarm and Control" system of "Pacific Gas and Electric Co.". Installed in 1972, this is a remote supervisory system for substation breakers and stored-energy-operated switches on the distribution circuit. Controlled by a human operator, alarm signals are received and control signals are transmitted to isolate faults and restore service. The objective is to reduce customer-minutes interruptions and to defer equipment capital cost.
3. RLBVC project of PEPCO³: The "Radial Load Bus Voltage Control" project of "Potomac Electric Power Co.". Installed in 1976, this is a fully automated function which uses Remote Terminal Units located at distribution substations and controlled by a consolidated Energy Control System in a closed-loop fashion. The control objectives consist of security (equipment protection) and operational (quality of service) requirements of all load centers, VAR/Voltage regulation by parallel transformers and capacitor banks.
4. Other current or planned activities are noted at Detroit Edison, San Diego Gas and Electric, Duquesne Light Co. and New England Power Services.

Publications:

1. Bunch, J.B., and Smith, J.A., "G.E. PROBE(s) Substation and Distribution Automation". Transmission and Distribution, Sept. 1977.
2. Beaty, W.H., "Distribution Automation". Electrical World, July 1977.
3. Arafat, S.A., Kilmer, R.E., and Rumbaugh, J.H., "Closed-Loop Computer Control of a System of Radial Load Busses". IEEE Trans. PAS Vol. PAS-96, Nov.-Dec. 1977.
4. Report of the Customer Communications Systems Task Force to EEI.

Comments:

Most developmental activities to date, in the area of DAC functions, have been dependent on each particular utility's needs. On-going development is aiming towards the integration of these functions. The allocation of these functions software and hardware within the system must be examined. The sub-systems, individual equipment and their physical locations must be viewed in total in determining DAC system requirements and needs for development.

EXAMPLES OF KEY ISSUES AND UNCERTAINTIES

- The Cost/Effectiveness of DAC functions implementation to utilities operation.
- The Cost/Effectiveness of DAC functions implementation to utilities service reliability.
- The Level of penetration of DAC beyond the distribution substation and its functional requirements.
- The types of "DSC" components to be integrated, time frames, and resultant functional requirements.
- The impact of DAC on Energy Management Systems and/or SCADA systems centralization and decentralization (do new functional requirements arise?).
- The monitoring and control functions' communication and data handling requirements.
- The coordination of system-wide versus distribution monitoring and control functions (what additional functional requirements are required due to this coordination?).

Technical and economic problems resulting from increasing demand for electrical energy and the growing scarcity of oil and natural gas are forcing the shift to energy conservation techniques such as co-generation and to the utilization of unconventional energy sources such as solar and wind power. Coupled with these developments are techniques for storing energy during periods of light load demand. The development of these new technologies and the integration of them into the utility system require new technological advances and present new design problems to the utility engineer.

The development of Distribution Automation and Control (DAC) is required for the integration of new sources within the utility distribution system. DAC will provide the communications, power processing, automation, control and protection, required when unconventional energy sources such as fuel cells, photo voltaic, solar thermal, wind, geothermal, and batteries, are integrated into electric utility distribution system.

BACKGROUND INFORMATION

Present Activities:

1. Integration of new energy sources into the utility distribution system is relatively new. Some utilities have, mostly on experimental bases, incorporated small sources into their system, or are planning to do so. For example:
 - a. In the fuel cell area, United Technology (UTC) is developing a 4.8 MWe unit for integration into Con Ed (N.Y.) system in 1979. UTC has developed a large self-commuted inverter for commercial fuel cell on-line demonstration with a 1 MW demonstration plant (Ref. 1). In addition UTC has initiated EPRI/DOE directed work to adapt this technology to utility energy storage.
 - b. In the cogeneration area many small sources resulting from cogeneratic topping and botvoming cycies have been integrated into some utilities at customer industrial sites. For example: SDG&E cogenerates at the Naval Training Center in San Diego using heat recovery boilers using existing turbines located at substations. The voltage level is 12.5KV. The power tied to the line and is not dispatched. The existing plants have local control (manned), providing status information to the utility center. However SDG&E is aware that as more plants of this type go into production, automation and control including centered computers, tele-metry and communication, etc. are needed.

Publication:

1. Phillips, G.A., et.al., "Progress in Self-Commuted Investors for Fuel Cells and Betteries", IEEE PES, 1978.

Comments:

Since the number of unconventional energy sources connected to utility distri-

bution system is small the impact of these sources on utility systems has been negligible. Furthermore there have been few technical problems associated with interfacing these small units and the associated power processing. However as the number and size of these unconventional energy sources in the utility distribution system increases greatly, the interfacing and operational problems also increase.

In the future a utility may require to know the status of all the unconventional energy sources connected to its distribution system, so that it may determine where the energy is coming from and how the load demand is or will be met. Furthermore the utility may desire to directly control (dispatch) some of these resources to meet either its normal operational needs (based on economics, etc.) or alternatively to meet its emergency operational needs when such emergencies do occur. Then the monitoring and control capabilities of the distribution system and its components will play a major role in determining how fast and to what extent the unconventional energy sources will be incorporated in the utility distribution system.

EXAMPLES OF KEY ISSUES AND UNCERTAINTIES

- The considerations of operational and maintenance needs, and code constraints in designing DAC elements for new source integration.
- The implications of the timing of various new energy resources installations on the requirements for DAC systems. (What is the need in terms of time periods?)
- What requirements for operation of dispersed new sources will arise from utilities criteria for supply system characteristics?
- How will the control of the new dispersed sources be affected by load control, reactions to the emergency state, and the more routine operations of the distribution system?
- What are the needs for information as to costs, status, capability, energy available, fuel status and availability, for the day to day operations of these new sources when added to the utilities supply mix?
- What are the specific provisions for operations and maintenance personnel required as a result of connecting sources at locations throughout the distribution system?

APPENDIX E

BIBLIOGRAPHY: RECENT RELEVANT PUBLICATIONS AND PAPERS

APPENDIX E

BIBLIOGRAPHY: RECENT RELEVANT PUBLICATIONS AND PAPERS

This appendix is not a comprehensive DAC bibliography, but a listing of certain related papers identified by the DAC Working Group participants.

Communications Systems and Automatic Meter Reading.

1. Blose, J.B., Automatic Meter Reading at Philadelphia Electric Company with the General Electric Company Phase II AMRAC Equipment, EEI/AEIC Meter and Services Committee, Philadelphia, Sept. 21, 1976.
2. Blose, J.B., Automatic Meter Reading at Philadelphia Electric Company - A Progress Report, Penn. Elec. Assn., Engineering Section, Oct. 17, 1975.
3. Blose, J.B., Automatic Meter Reading - Trial by Philadelphia Electric Company, Penn. Elec. Assn., Communications Committee, Feb. 1, 1974.
4. "Communication and Automation - Partners in Protection and Control," Electric Forum, Vol. 4, No. 1, 1978.
5. Berkowitz, D., Jordan, S.A., and Nickel, D.L., Both Generating and Non-Generating Utilities Can Benefit from the Use of the Distribution Line Carrier System, Westinghouse Electric Co.
6. Berkowitz, D., Jordan, S.A., and Nickel, D.L., The Distribution Line Carrier System - Versatile and Economical, Westinghouse Electric Co.

Load Management and Load Control

7. Preiss, R.F., and Warnock, V.J., "Impact of Voltage Reduction on Energy and Demand," Transaction Paper #78-015, IEEE 1978 Winter Power Engineering Society Meeting.
8. Sella, R.A., Landgren, D.A., and Lokken, G., Wisconsin Electric Power Company System Load Management Program, CP77-07, Wisconsin Electric Power Co., Dec. 1977.
9. The Role of Load Management in Ontario, Report #ECD-78-6, Ontario Hydro Energy Conservation Division, Load Management Dept.
10. Bowles, R.T., and Barron, W.L., Time of Day Update and Load Management, EEI-System Planning Committee, May 1, 1978 (Florida Power Corp.).

11. Robinson, P.B., "Load Management System," Electric Forum, Vol. 3, No. 4, 1977.
12. Berkowitz, D., Jordan, S.A., and Nickel, P.L., A Look at Load Management for Non-Generating Utilities - Update, Westinghouse Electric Co.
13. Berkowitz, D., Jordan, S.A., and Nickel, P.L., The Value of the Distribution Line Carrier System for Load Management, Westinghouse Electric Co.
14. Philipp, H.D., Fernandez, R.A., and Rushden, F.A., Utility Responsibility for Load Management, IEEE Electro '77, Niagara Mohawk Corp.
15. Kitching, H., "New England Utility Uses Voltage, Current Waves for Load Control," Transmission & Distribution, Sept. 1977.
16. Caldwell, R., Development and Design Criteria for Citywide Electric Load Management and Control Systems, American Public Power Association.
17. Caldwell, R., "Utility Controlled Management of Industrial Customers' Electrical Loads." WATTEC, Feb. 1978.

Dispersed Storage and Generation (DSG)

18. Miller, D.M., and Coleman, W.R., "Residential Electric Storage - A Field Test Program to Measure Utility and Consumer Benefits from Using Electric Thermal Storage Devices," Winter Power Engineering Society Meeting, 1978.
19. Kuliasha, M., "Impact of Thermal Storage on the Electrical Distribution System," Summer Transmission & Distribution IEEE Conference, 1978.

Reliability

20. "Distribution System Reliability Roundtable," Electric Forum, Vol. 3, No. 4, 1977 (panel interview).

System Control and General DAC

21. McCall, L.V., and Filter, R., Quantifying the Benefits of Distribution System Automation, Canadian Electrical Association Research Project 76-B, Ontario Hydro Research Division.

22. Schweppe, F.C., Tabors, R.D., and Kirtley, J.L., Homeostatic Utility Control, MIT Electric Power System Laboratory, Nov. 1978.
23. "G.E. Probes Substation and Distribution Automation," Transmission & Distribution, Sept. 1977.
24. Croghan, J.F., Jenkins, D.R., Rushden, F.A., Bunch, J.B., and Garr, G.P., "Probe - A Feasibility Demonstration of Substation and Distribution Automation," American Power Conference, 1977.
25. Lokken, G., "Wisconsin Electric Takes a First Step Towards ADS, Transmission & Distribution, Sept. 1977.