

NASA
TP
1474
c. 1

NASA Technical Paper 1474

Moisture Diffusion Parameter Characteristics for Epoxy Composites and Neat Resins

Edward R. Long, Jr.

AUGUST 1979

LOAN COPY: RETURN TO
AFWL TECHNICAL LIBRARY
KIRTLAND AFB. N. M.

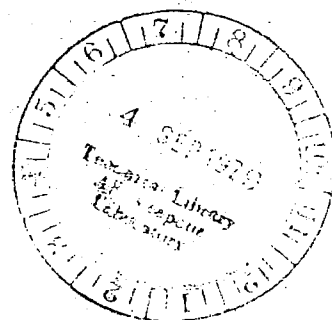



NASA Technical Paper 1474

Moisture Diffusion Parameter Characteristics for Epoxy Composites and Neat Resins

Edward R. Long, Jr.
*Langley Research Center
Hampton, Virginia*



National Aeronautics
and Space Administration

**Scientific and Technical
Information Branch**

1979

SUMMARY

The moisture absorption characteristics of two graphite/epoxy composites and two cured epoxy neat resins in high humidity and water immersion environments at elevated temperatures have been studied. The values of moisture absorption parameters - such as equilibrium moisture contents and diffusion coefficients - were compared for the high humidity and water immersion environments. Composite swelling in a water immersion environment was correlated with moisture content. Tensile strengths of cured neat resin were measured as a function of moisture content. Intermittent, short duration moderate tensile loads were applied to composite and cured neat resin specimens during moisture absorption, and their effects on moisture absorption were determined.

Composite and cured neat resin specimens exposed to high temperature/high humidity environments had larger diffusion coefficients and smaller equilibrium moisture contents than those exposed to high temperature/water immersion environments. The equilibrium moisture content of composites could be approximately predicted from the equilibrium moisture content of cured neat resins. Composite swelling and moisture content had the same time dependent functional form. Cured neat resins soaked in water until an equilibrium moisture content occurred had approximately 18 percent less ultimate tensile strength than did dry neat resins. Short duration moderate loads reduced the moisture diffusion coefficients of the composites and increased their equilibrium moisture content. The moisture absorption parameters for the cured neat resin were unaffected by the short duration intermittent moderate loads.

INTRODUCTION

Organic matrix composites have lower mass densities and higher mechanical strengths than many metallic materials presently used for aircraft structures. Therefore, composites are being considered for use in civilian and military aircraft. A major concern with organic composites is their absorption of moisture and accompanying loss in strength.

References 1 to 13 are representative of the studies of moisture absorption in organic matrix composites. These studies report values for moisture diffusion parameters, mechanical properties of composites before and after moisture absorption, theoretical models of absorption and diffusion, and in one study (ref. 11), an experiment to determine the chemical state of the absorbed moisture. Moisture-diffusion and mechanical-property data for cured neat resins before and after moisture absorption are not reported. These studies do not include data to show what effect other service environmental parameters, such as intermittent loads, have on moisture absorption.

This paper reports moisture-diffusion parameter data for graphite/epoxy composites and corresponding cured neat resins exposed to high relative humidity and water immersion environments at elevated temperatures. Differences

in the values of the diffusion parameters for different environments are discussed in terms of hydrogen bonding. A diffusion model is used to develop an equation that relates values of the diffusion coefficients of composites and cured neat resins. Cured neat resin tensile strengths and composite swelling data are obtained as a function of moisture content. Effects of intermittent short duration moderate tensile loads on moisture absorption are also reported.

Identification of commercial products in this report is to adequately describe the materials and does not constitute official endorsement, expressed or implied, of such products or manufacturers by the National Aeronautics and Space Administration.

SYMBOLS

D	diffusion coefficient, m^2/s
D_0	permeability index, m^2/s
d	apparent thickness, m
E	activation energy, kJ/g
h	measured thickness, m
l	distance between adjacent fiber centers, m
l_s	distance between adjacent fiber surfaces, m
M	moisture content at time t, percent mass
M_m	equilibrium moisture content, percent mass
R	gas constant, 8.315 J/g-K
r	fiber radius, m
T	temperature, K
T/H ₂ O	combined temperature and water immersion environment, K/H ₂ O
T/φ	combined temperature and humidity environment, K/percent
t	time, s
v_f	fiber volume fraction, percent
v_r	volume fraction of resin, percent
W	mass at time t, g
W_d	dry mass, g

W_m mass for equilibrium moisture content, g
 w_r resin mass fraction, percent
 ϕ relative humidity, percent

Subscripts:

c composite
r cured neat resin

EXPERIMENTAL

Materials and Test Samples

Materials.- The materials used to make samples for this study were T300/5208 and AS/3501-5 prepreg and 5208 and 3501-5 solid resin. Thornel 300 graphite fiber is manufactured by Union Carbide Corporation; 5208 epoxy resin is manufactured by Narmco Materials, a subsidiary of Celanese Corporation; AS graphite fiber and 3501-5 epoxy resin are manufactured by Hercules Incorporated.

Cured, four-ply unidirectional composite panels were made according to the recommendations of the prepreg suppliers. Cured neat resin panels were also made according to the suppliers' recommendations using the temperature and time sequence given in table I. Unless otherwise noted, composite samples were machined from the composite panels to dimensions of 25 by 51 mm, and cured neat resin samples were machined from cured panels to dimensions of 25 by 51 by 0.5 mm.

Samples for diffusion.- Composite and cured neat resin samples for measurement of moisture diffusion parameters were dried to a constant weight at 344 K over a silica gel desiccant. The drying period was approximately 3 weeks. After drying, a small hole was drilled in one end of each sample for an identification tag and suspension wire, and the dry weight was recorded.

Samples for swelling.- Swelling measurements were made on 24-ply unidirectional laminates. They were dried to a constant weight at 344 K over a silica gel desiccant. The drying period was approximately 2 months. Their dry weights were recorded and they were identified on their edges with waterproof ink.

Samples for tensile strengths.- The effect of moisture absorption on tensile strength was determined only on cured neat resin samples and these were dried as for diffusion measurements and weighed. Tabs, made from bead-blasted aluminum, were bonded to both sides of each end as shown in figure 1. The holes in the tabs were used for alignment in the test apparatus.

Samples for intermittent loads.- Composite and cured neat resin samples were prepared with tabs as described in the preceding paragraph and figure 1.

Experimental Equipment and Procedures

Environmental chambers.- Four commercially available bell-jar environmental chambers were operated at temperature/humidity (K/percent) values of 344/95, 344/75, 322/95, and 322/75. The values of stability for ϕ and T were ± 0.1 percent and $\pm 0.5^\circ$ C, respectively. A hoist was used to quickly raise and lower the bell jars for sample insertion and removal. A dry-bulb temperature drop of 2° to 5° C occurred for about 3 min each time the bell jar was raised. A wet-bulb temperature drop of 1° to 2° C occurred for the same interval.

Samples were placed in the chambers after their dry mass had been recorded. Figure 2 shows groups of samples suspended from the arms of hanger stands. Six composite and six cured neat resin samples were exposed per environment. The temperature/water (liquid) environment (T/H₂O) was achieved by placing a group of six samples in a closed jar of distilled water which, in turn, was placed in a bell jar chamber at the desired temperature.

Semimicrobalance.- The semimicrobalance had a resolution of $\pm 10^{-5}$ g. The balance was calibrated with an NBS 100-mg standard prior to weighing each group of samples. The weighing process for the group required 3 min or less and, except for the time of actual weighing, the samples were stored in a preheated Dewar vessel that contained moist air.

Universal tester.- An Instron universal testing machine was used to determine the ultimate tensile strengths of the cured neat resin samples. Samples were tested at ambient room temperature and relative humidity after equilibrium moisture content was established at an elevated temperature.

Tension load device.- Figure 3 is a photograph of the device used to apply loads to composite and neat resin samples during their moisture absorption period. The samples were held in place by pins that passed through the end tabs of the samples and the yokes on the device. The loads were slowly applied and removed to minimize load shock.

Two groups of samples from every environment investigated were loaded. The first group was intermittently loaded for 5 min only during the environmental exposure, that is, after each weighing. The second group, which is referred to as the preloaded group, was additionally loaded prior to environmental exposure for 5 min while dry. The samples were returned to their T/ ϕ environment after loading. The values of the stress were moderate: 34.5 MPa for loading in the fiber direction and 4.5 MPa for loading transverse to the fiber direction.

Dial comparator.- A bench-top dial comparator was used to measure thickness swelling due to moisture absorption. The resolution of the comparator was 0.254 mm. Swelling measurements were made on 24-ply unidirectional composite samples immediately after they were weighed.

TEST RESULTS

The exposure environments used for the various experiments reported in this paper are given in table II. A model for diffusion and an analysis to determine diffusion parameters are given in the appendix.

Absorption Parameters

Equilibrium moisture content.- Values for the equilibrium moisture content of the composite and cured neat resin samples are shown in table III. The values were higher for environments with higher moisture burdens and were dependent on temperature.

The equilibrium moisture content for both types of composites was about 25 percent of the observed equilibrium moisture content of the cured neat resin samples. The ratios of resin mass to total mass for the T300/5208 and AS/3501-5 composites were 0.28 and 0.31, respectively. The similarity of the ratios $M_{m,c}/M_{m,r}$ and resin mass to total mass content may indicate that $M_{m,c}$ values are approximated by $w_r M_{m,r}$. These approximations are included in table III.

Diffusion coefficients.- Table IV contains the values of the diffusion coefficients for the composite and the cured neat resin samples. These data were obtained from an adaptation of equation (A1), $D = (16/\pi) (\text{Slope}/M_m)^2$, where the values of slope and M_m are determined from absorption curves similar to figure 4. The values for D , except in one case, are lower for water immersion than for 95 percent relative humidity environments.

A model for diffusion is used in the appendix to develop an expression (eq. (A8)) for predicting diffusion coefficients for composites from diffusion coefficients of cured neat resin samples. The predictions are tabulated in the last column of table IV. The predicted values are in good agreement with the experimental values.

Activation energy.- The activation energy values for moisture absorption in composite and cured neat resin samples are given in table V. These values were determined from the relation $D = D_0 e^{-E/RT}$ and the previously determined values of D for two different temperatures.

Swelling.- Swelling data, the change in thickness, from T300/5208 composites are plotted as a function of moisture content in figure 5. The straight-line fit implies that swelling is linearly dependent on moisture content.

Cured Neat Resin Tensile Strength and Modulus

The tensile strength and modulus of 5208 cured neat resin samples exposed to different exposure environments are given in table VI. The tensile strength

after soaking in water to equilibrium was approximately 18 percent smaller than for dry samples. The modulus values were not significantly affected by moisture absorption.

Effects of Intermittent Loading on Moisture

Absorption Parameters

Table VII contains the absorption data for composite samples subjected to moderate intermittent loads. Higher equilibrium moisture content and lower diffusion coefficients were observed for these samples than for samples that were not subjected to loading. The values of absorption parameters for resins were not affected by intermittent loads.

DISCUSSION

Resin Dominated Properties

The equilibrium moisture contents in table III are plotted in figure 6 for composites and in figure 7 for cured neat resins. In both plots the M_m values for water immersion have been placed at $\phi = 100$ percent. A curve, $M_m = a\phi^b$, has been fitted to the ϕ data excluding the water immersion data in the same manner as in reference 6. The values of coefficients for each material are given in the following table:

Material	a	b
T300/5208	0.0021	1.3900
AS/3501-5	.0012	1.5200
5208	.0032	1.0900
3501-5	.0034	1.6100

For both cured resins and composites, the projected M_m for $\phi = 100$ percent are approximately 20 percent less than M_m measured for water immersion. The 20-percent difference implies that $\phi = 100$ percent and water immersion environments are not equivalent. The same difference between M_m values for water immersion and projected $\phi = 100$ percent for both cured neat resin and corresponding composite suggests that the matrix controls the equilibrium moisture content.

In figure 8, the strength data for the cured 5208 neat resin, from table VI, are plotted as a function of total moisture content in the sample. The shape and magnitudes of the curve are very similar to ultimate tensile strength data given in reference 13 for transversely loaded, unidirectional

graphite/epoxy samples. The ultimate strengths are most sensitive to equilibrium moisture content between 3.5 percent, which occurred for $\phi = 75$ percent, and 4.7 percent, which occurred for $\phi = 95$ percent.

Moisture Absorption Mechanism

The moisture absorption activation energies in table V are within the limits of energy values generally associated with hydrogen bonding. (See ref. 14.) The magnitudes, which are approximately twice those associated with a single hydrogen bond, suggest that each absorbed water molecule breaks two hydrogen bonds within the resin structure; thus, a double hydrogen bond may be formed between the water molecule and the resin molecule. This interpretation is supported by data given in references 10 and 11. Reference 10 presented data showing that the glass transition temperature was lower for epoxy composites with absorbed moisture; that is, the free volume was greater. Creation of free volume to accommodate the incoming moisture requires the Van der Waals interaction and hydrogen bonding between adjacent molecules to be broken. In reference 11, the data imply that hydrogen bonding occurs between the absorbed water and resin molecules. Further support for this interpretation can be obtained from the swelling data given in figure 5. Material swelling could imply that intermolecular distances were increased through bond breakage to accommodate the absorbed moisture.

Diffusion Parameters

The preceding discussion of absorbed moisture interaction with the cured resin suggests an interpretation for the M_m and D values reported in tables III and IV. The equilibrium moisture contents $M_{m,r}$ and $M_{m,c}$ for water immersion are limited by the number of hydrogen bonds that can be broken, and $M_{m,c}$ is proportional to the resin fraction in the composite. The $M_{m,r}$ and $M_{m,c}$ values for exposures to moist air are smaller than for water soaks. The comparison of equilibrium moisture contents of a material exposed to different environments may correspond to a comparison of the moisture burdens of those environments. The rate of diffusion, slope of the curve in figure 4, may be limited by the rate at which hydrogen bonds in the resin are broken.

Equation (A8) relates D_c to D_r by the amount of resin in the composite, that is v_f , and by taking into account that the diffusing moisture must pass around the fibers. Therefore, the good agreement between predicted and experimental D_c values is not surprising.

Intermittent Load Effects

The diffusion coefficient and equilibrium moisture content of the cured neat resin were not affected by intermittent loads. For the composite samples, $M_{m,c}$ was larger and D_c was lower for loading than for no loading. These results might be explained by internal void formation at the fiber/resin interfaces. Internal void formation could create a large volume in which additional

moisture could be absorbed; that is, $M_{m,c}$ would be larger. The rate of diffusion, slope of absorption curve, is controlled by the unaffected resin-rich surface and therefore remains the same, requiring a lower D_c . (See eq. (A1).)

Internal void formation at the fiber/resin interface is suggested by two observations: first, microscopic inspection of the failure line of transversely loaded samples showed that fibers had been pulled cleanly out of the resin; second, values of the absorption parameters of the cured neat resin samples did not change when intermittent loads were applied.

CONCLUDING REMARKS

Moisture absorption tests were performed on T300/5208 and AS/3501-5 composites and 5208 and 3501-5 cured neat resins, with and without intermittent external loading. The following observations are made:

(1) Moisture absorption in the two composites studied is controlled by resin properties.

(2) Cured neat resins had approximately 18 percent less ultimate tensile strength after equilibrium absorption in a water soak environment.

(3) Moisture content was higher in composite specimens subjected to intermittent moderate tensile loads during moisture absorption than in those that were not loaded. Moisture content in neat resin was not affected.

(4) The equilibrium moisture contents of composites and cured neat resins are larger for water immersion than for 100 percent relative humidity environment.

(5) The diffusion coefficients for composites and cured neat resins are smaller for water immersion than for 95 percent relative humidity environment.

(6) Moisture absorption activation energies for the moisture absorption suggest that hydrogen bonding in the resin structure is broken by the absorbed moisture and absorbed moisture is weakly bonded to the resin molecules.

(7) The values for the composite diffusion coefficient may be predicted from the values for the neat resin diffusion coefficient.

Langley Research Center
National Aeronautics and Space Administration
Hampton, VA 23665
June 8, 1979

APPENDIX

MODEL FOR DIFFUSION OF MOISTURE IN COMPOSITES

The equation developed in this appendix enables a prediction for values of diffusion coefficients of a graphite/epoxy composite, for a limited range of fiber volume fraction, from diffusion coefficient values of the corresponding neat resin. The assumptions made for the development are that Fick's Law may be applied, that Fick's Law applies for the initial absorption, and that the fibers do not absorb moisture.

An expression for the diffusion coefficient was obtained from a solution to Fick's Second Law for short time. The short time transient solution for an infinite plate, initially dry and exposed on each side to a constant moist environment, is arranged to give (ref. 6)

$$D = \frac{M^2}{M_m^2} \frac{d^2}{16 t} \pi \quad (A1)$$

This relation for neat resins is

$$D_r = \frac{M_r^2}{M_{m,r}^2} \frac{d_r^2}{16 t} \pi \quad (A2)$$

and for composites is

$$D_c = \frac{M_c^2}{M_{m,c}^2} \frac{d_c^2}{16 t} \pi \quad (A3)$$

where d_r and d_c are path lengths or apparent specimen thicknesses as seen by the absorbed moisture. For equal diffusion times, equations (A2) and (A3) are combined to give

$$D_c = \left(\frac{M_c}{M_r} \right)^2 \left(\frac{M_{m,r}}{M_{m,c}} \right)^2 \left(\frac{d_c}{d_r} \right)^2 D_r$$

The M terms in this relation are expressed in terms of mass. For example,

$$M_c = \frac{W_c - W_{d,c}}{W_{d,c}} 100$$

Thus,

$$D_c = \left(\frac{W_c - W_{d,c}}{W_r - W_{d,r}} \right)^2 \left(\frac{W_{m,r} - W_{d,r}}{W_{m,c} - W_{d,c}} \right)^2 \left(\frac{d_c}{d_r} \right)^2 D_r \quad (A4)$$

APPENDIX

where W_C and W_R are wet masses at time t , $W_{d,C}$ and $W_{d,R}$ are dry masses, and $W_{m,C}$ and $W_{m,R}$ are equilibrium wet masses for the composite and resin, respectively.

A geometric model is required to reduce equation (A4) to a form that does not require knowing the equilibrium mass of moisture of the composite. The model is shown schematically in figure 9. Previously derived relations for predicting composite diffusion coefficient values (refs. 6 to 9) have assumed that an end view of the fiber in a unidirectional composite would appear in a square array. This is unlikely since the fibers will tend to nestle together and form a hexagonal array, as shown in figure 9. In figure 9, l is the distance between centers of adjacent fibers, r is the fiber radius, and l_s is the distance between surfaces of adjacent fibers. The moisture is assumed to diffuse perpendicular to the fiber direction.

For any cross section in the composite the absorbed moisture may only pass through a fraction l_s/l of that cross section. If an assumption is made that at time t the amount of absorbed moisture in the composite is proportional to the amount of moisture that would be absorbed in a neat resin of the same surface area then

$$W_C - W_{d,C} \propto W_R - W_{d,R}$$

If the proportionality constant is the surface fraction through which moisture diffusion occurs, then

$$W_C - W_{d,C} = \frac{l_s}{l} (W_R - W_{d,R}) \quad (A5)$$

For equilibrium moisture content, the weight gain in the composite is dependent on the volume percent of resin v_r ; therefore,

$$W_{m,C} - W_{d,C} = v_r (W_{m,R} - W_{d,R}) \quad (A6)$$

where $W_{m,R} - W_{d,R}$ is the maximum absorption of an equal total volume of neat resin.

Substitution of equations (A5) and (A6) into equation (A4) yields

$$D_C = \left(\frac{l_s}{l}\right)^2 \left(\frac{1}{v_r}\right)^2 \left(\frac{d_C}{d_R}\right)^2 D_R \quad (A7)$$

The term v_f is the ratio of the fiber area to the hexagonal area in figure 9; therefore, $v_f = r^2/0.866l^2$ or, since $2r = l - l_s$,

APPENDIX

$$\frac{l_s}{l} = 1 - 2\sqrt{0.866v_f/\pi}$$

Substitution of the expression for l_s/l into equation (A7) yields

$$D_C = \left(\frac{1 - 2\sqrt{0.866v_f/\pi}}{1 - v_f} \right)^2 \left(\frac{d_C}{d_r} \right)^2 D_r$$

For the composite, assuming the fibers do not absorb, the moisture is deflected around the fibers. A typical path of the deflected flow that includes composite symmetry is shown as the heavy line in figure 9. For this path $d_C = 1.334h_C$, where h_C is the thickness of the composite. In this experiment, $h_C = h_r$ and $d_r = h_r$; thus,

$$D_C = (1.334)^2 \left(\frac{1 - 2\sqrt{0.866v_f/\pi}}{1 - v_f} \right)^2 D_r \quad (A8)$$

This relationship is restricted to composites with high fiber volume fractions, because of the choice of path for flow in the composite.

REFERENCES

1. Browning, C. E.; Husman, G. E.; and Whitney, J. M.: Moisture Effects in Epoxy Matrix Composites. Composite Materials: Testing and Design (Fourth Conference), ASTM Spec. Tech. Publ. 617, c.1977, pp. 481-496.
2. McKague, E. L., Jr.; Reynolds, J. D.; and Halkias, J. E.: Moisture Diffusion in Fiber Reinforced Plastics. Trans. ASME, Ser. H: J. Eng. Mater. & Technol., vol. 98, no. 1, Jan. 1976, pp. 92-95.
3. Browning, Charles E.: The Mechanism of Elevated Temperature Property Losses in High Performance Structural Epoxy Resin Matrix Materials After Exposures to High Humidity Environments. Ph. D. Diss., Univ. of Dayton, 1976.
4. Kaelble, D. H.; Dynes, P. J.; and Cirilin, E. H.: Interfacial Bonding and Environmental Stability of Polymer Matrix Composites. J. Adhes., vol. 6, no. 1/2, 1974, pp. 23-48.
5. Kaelble, D. H.; Dynes, P. J.; Crane, L. W.; and Maus, L.: Interfacial Mechanisms of Moisture Degradation in Graphite-Epoxy Composites. J. Adhes., vol. 7, no. 1, 1975, pp. 25-54.
6. Springer, George S.; and Shen, Chi-Hung: Moisture Absorption and Desorption of Composite Materials. AFML-TR-76-102, U.S. Air Force, June 1976. (Available from DDC as AD A031 436.)
7. Augl, J. M.; and Berger, A. E.: Moisture Effect on Carbon Fiber Epoxy Composites. Bicentennial of Materials, Volume 8 of National SAMPE Technical Conference Series, Soc. Advance. Mater. & Process Eng., c.1976, pp. 383-427.
8. Springer, George S.; and Tsai, Stephen W.: Thermal Conductivities of Unidirectional Materials. J. Compos. Mater., vol. 1, no. 2, Apr. 1967, pp. 166-173.
9. Tompkins, Stephen Stern: Analysis of Moisture Absorption and Diffusion in Fiber Reinforced Polymeric Resin-Matrix Composite Materials. Ph. D. Diss., Old Dominion Univ., 1978.
10. Sykes, George F.; Burks, Harold D.; and Nelson, James B.: The Effect of Moisture on the Dynamic Thermomechanical Properties of a Graphite Epoxy Composite. Diversity - Technology Explosion, Volume 22 of National SAMPE Symposium and Exhibition, Soc. Advance. Mater. & Process Eng., c.1977, pp. 350-364.

11. Fuller, R. T.; Fornes, R. E.; and Memory, J. D.: NMR Study of Water Absorbed by Epoxy Resin. *J. Appl. Polym. Sci.*, vol. 23, no. 6, Mar. 1979, pp. 1871-1874.
12. Whitney, J. M.; and Browning, C. E.: Some Anomalies Associated With Moisture Diffusion in Epoxy Matrix Composite Materials. *Advanced Composite Materials - Environmental Effects*. J. R. Vincent, ed., ASTM Spec. Tech. Publ. 658, c.1978, pp. 43-60.
13. Springer, George S.; and Shen, Chi-Hung: Effects of Moisture and Temperature on the Tensile Strength of Composite Materials. AFML-TR-77-82, U.S. Air Force, May 1977. (Available from DDC as AD A044 038.)
14. Billmeyer, Fred W., Jr.: *Textbook of Polymer Science*. Second ed. Wiley-Interscience, c.1971.

TABLE I.- TEMPERATURE AND TIME SEQUENCE FOR
CURING EPOXY RESINS

[Rate of temperature change, 1° C/min;
resins cured at ambient pressure]

5208		3501-5	
Temperature, K	Time, hr	Temperature, K	Time, hr
366	20	343	0.1
394	3	450	.5
422	2		
450	2		
477	4		

TABLE II.- EXPOSURE ENVIRONMENTS

Test	Material	Intermittent load	Preload	Load orientation	Temperature/moisture environment (a)					
					322/75	322/95	322/H ₂ O	344/75	344/95	344/H ₂ O
Weight gain measurement	T300/5208	No	No	Longitudinal Longitudinal Transverse Transverse Longitudinal Longitudinal	✓	✓	✓	✓	✓	✓
	AS/3501-5	No	No		✓	✓	✓	✓	✓	✓
	5208	No	No		✓	✓	✓	✓	✓	✓
	3501-5	No	No		✓	✓	✓	✓	✓	✓
	T300/5208	Yes	Yes		✓	✓	✓	✓	✓	✓
	T300/5208	Yes	No		✓	✓	✓	✓	✓	✓
	T300/5208	Yes	Yes		✓	✓	✓	✓	✓	✓
	T300/5208	Yes	No		✓	✓	✓	✓	✓	✓
	AS/3501-5	Yes	Yes		✓	✓	✓	✓	✓	✓
	AS/3501-5	Yes	No		✓	✓	✓	✓	✓	✓
5208	Yes	No	✓	✓	✓	✓	✓	✓		
Neat resin strengths	5208	No	No				✓	✓	✓	
Composite swelling	T300/5208	No	No			✓				

^aTemperature is in kelvins; moisture is relative humidity, 75% or 95%, or water immersion, H₂O, with 6 samples per exposure.

TABLE III.- COMPOSITE AND RESIN EQUILIBRIUM MOISTURE CONTENT

Material	Temperature/moisture environment	Experimental equilibrium moisture content, M_m , % mass	Predicted equilibrium moisture content, M_m , % mass
	(a)	(b)	(c)
T300/5208	322/75	0.92	1.01
	322/95	1.20	1.23
	322/H ₂ O	1.60	1.65
	344/75	0.80	0.98
	344/95	1.15	1.32
	344/H ₂ O	1.62	1.65
AS/3501-5	322/75	0.98	1.05
	322/95	1.30	1.43
	322/H ₂ O	1.70	1.98
	344/75	0.80	1.18
	344/95	1.21	1.80
	344/H ₂ O	1.78	2.17
5208	322/75	3.60	
	322/95	4.40	
	322/H ₂ O	5.90	
	344/75	3.50	
	344/95	4.70	
	344/H ₂ O	5.90	
3501-5	322/75	3.40	
	322/95	4.60	
	322/H ₂ O	6.40	
	344/75	3.80	
	344/95	5.80	
	344/H ₂ O	7.00	

^aTemperature is in kelvins; moisture is relative humidity, 75% or 95%, or water immersion, H₂O.

^bEach value is an average for 6 samples.

$$M_{m,c} = w_r M_{m,r}$$

TABLE IV.- COMPOSITE AND RESIN DIFFUSION COEFFICIENTS

Material	Temperature/moisture environment (a)	Diffusion coefficient, mm ² /s	
		Experimental (b)	Predicted (c)
T300/5208	322/75	1.20 × 10 ⁻⁷	1.20 × 10 ⁻⁷
	322/95	1.33	1.28
	322/H ₂ O	0.90	-----
	344/75	3.04	2.98
	344/95	3.26	3.12
	344/H ₂ O	2.29	2.43
AS/3501-5	322/75	1.25	1.14
	322/95	1.50	1.55
	322/H ₂ O	0.91	0.94
	344/75	3.06	2.93
	344/95	3.10	3.11
	344/H ₂ O	2.17	2.20
5208	322/75	3.74	
	322/95	3.97	
	322/H ₂ O	4.33	
	344/75	9.22	
	344/95	9.65	
	344/H ₂ O	7.52	
3501-5	322/75	3.18	
	322/95	4.33	
	322/H ₂ O	2.63	
	344/75	8.17	
	344/95	8.66	
	344/H ₂ O	6.14	

^aTemperature is in kelvins; moisture is relative humidity, 75% or 95%, or water immersion, H₂O.

^bExperimental values are determined from the relationship $D = (\pi/16)(\text{Slope}/M_m)^2$ and absorption data.

^cTheoretical values are determined from equation (A7).

TABLE V.- COMPOSITE AND RESIN ACTIVATION ENERGIES FOR
MOISTURE DIFFUSION

Material	Environment (a)	Activation energy, kJ/g
T300/5208	75	39.3
	95	35.9
	H ₂ O	37.7
AS/3501-5	75	36.0
	95	40.2
	H ₂ O	44.8
5208	75	37.7
	95	38.5
	H ₂ O	38.5
3501-5	75	38.0
	95	33.9
	H ₂ O	33.9

^aRelative humidity, 75% or 95%, or water immersion, H₂O.

TABLE VI.- TENSILE PROPERTIES OF MOIST CURED 5208 NEAT RESIN IN SEVERAL
TEMPERATURE/HUMIDITY ENVIRONMENTS

Temperature/moisture environment (a)	Equilibrium moisture content, %	Tensile ultimate, MPa	Tensile modulus, MPa
Dry	0.0	44.8	13.1 × 10 ²
344/75	3.5	42.8	12.4
344/95	4.7	37.9	13.1
344/H ₂ O	5.9	36.5	13.1

^aTemperature is in kelvins; moisture is relative humidity, 75% or 95%, or water immersion, H₂O; dry signifies samples were dried in a dessicated environment at 344 K.

TABLE VII.- MOISTURE DIFFUSION PARAMETERS FOR COMPOSITES SUBJECTED TO
INTERMITTENT TENSILE LOADS

Material	Temperature/moisture environment (a)	Stress magnitude/direction, MPa	Preload magnitude/direction, MPa	Equilibrium moisture content, %	Diffusion coefficient, mm ² /s
T300/5208	344/95	34.5/longitudinal	34.5/longitudinal	1.80	0.97 × 10 ⁻⁷
	344/95	34.5/longitudinal	None	1.76	0.88
	344/95	4.5/transverse	4.5/transverse	1.76	1.47
	344/95	4.5/transverse	None	2.14	0.70
	344/H ₂ O	34.5/longitudinal	34.5/longitudinal	4.80	0.70
	344/H ₂ O	34.5/longitudinal	None	5.40	0.55
	344/H ₂ O	4.5/transverse	4.5/transverse	3.84	0.59
	344/H ₂ O	4.5/transverse	None	3.65	1.15
AS/3501-5	344/95	34.5/longitudinal	34.5/longitudinal	2.13	1.02
	344/95	34.5/longitudinal	None	2.14	1.02
	344/H ₂ O	34.5/longitudinal	34.5/longitudinal	5.01	0.64
	344/H ₂ O	34.5/longitudinal	None	5.00	0.64

^aTemperature is in kelvins; moisture is relative humidity, 95%, or water immersion, H₂O.

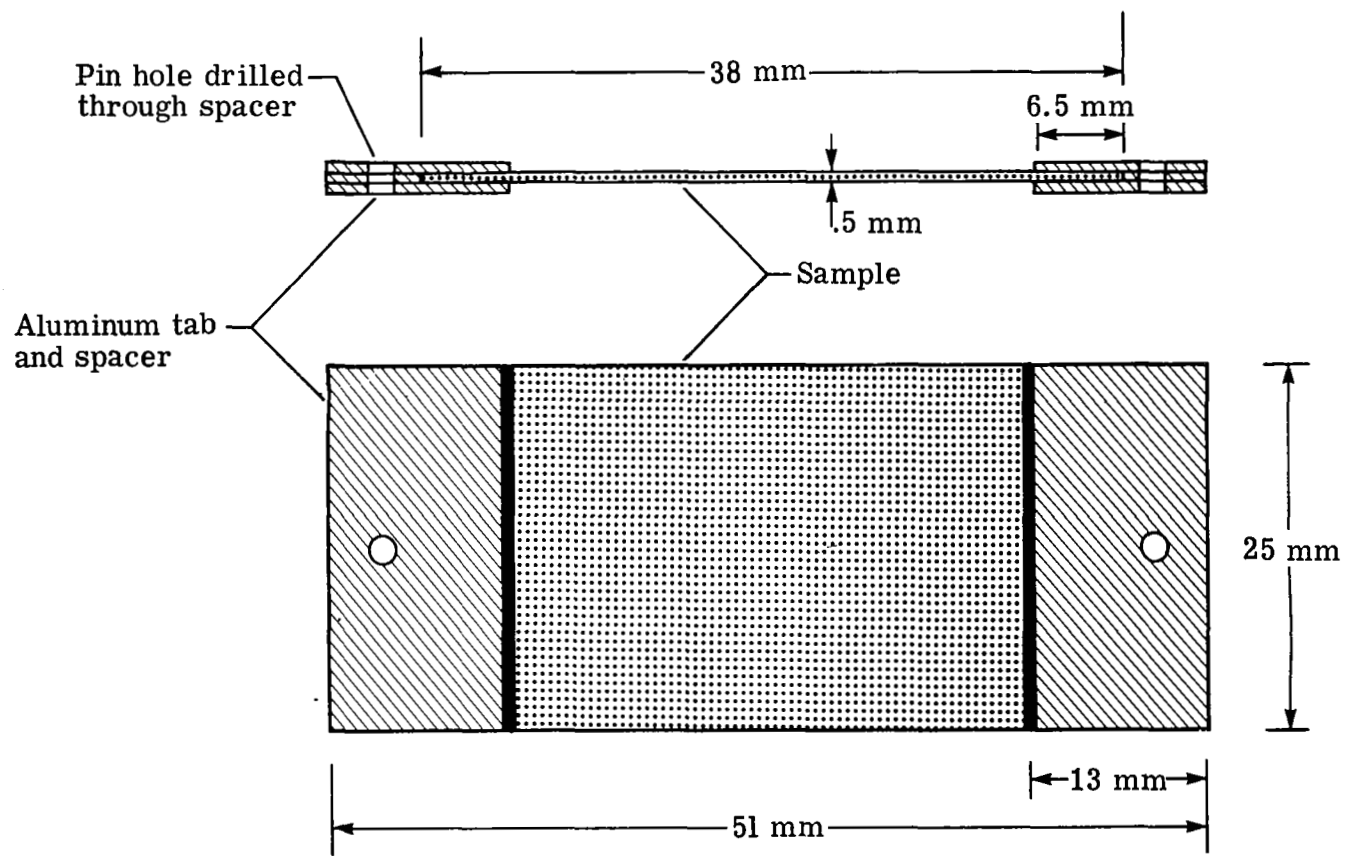

Figure 1.- Configuration used for mounting aluminum tabs and spacers on samples.

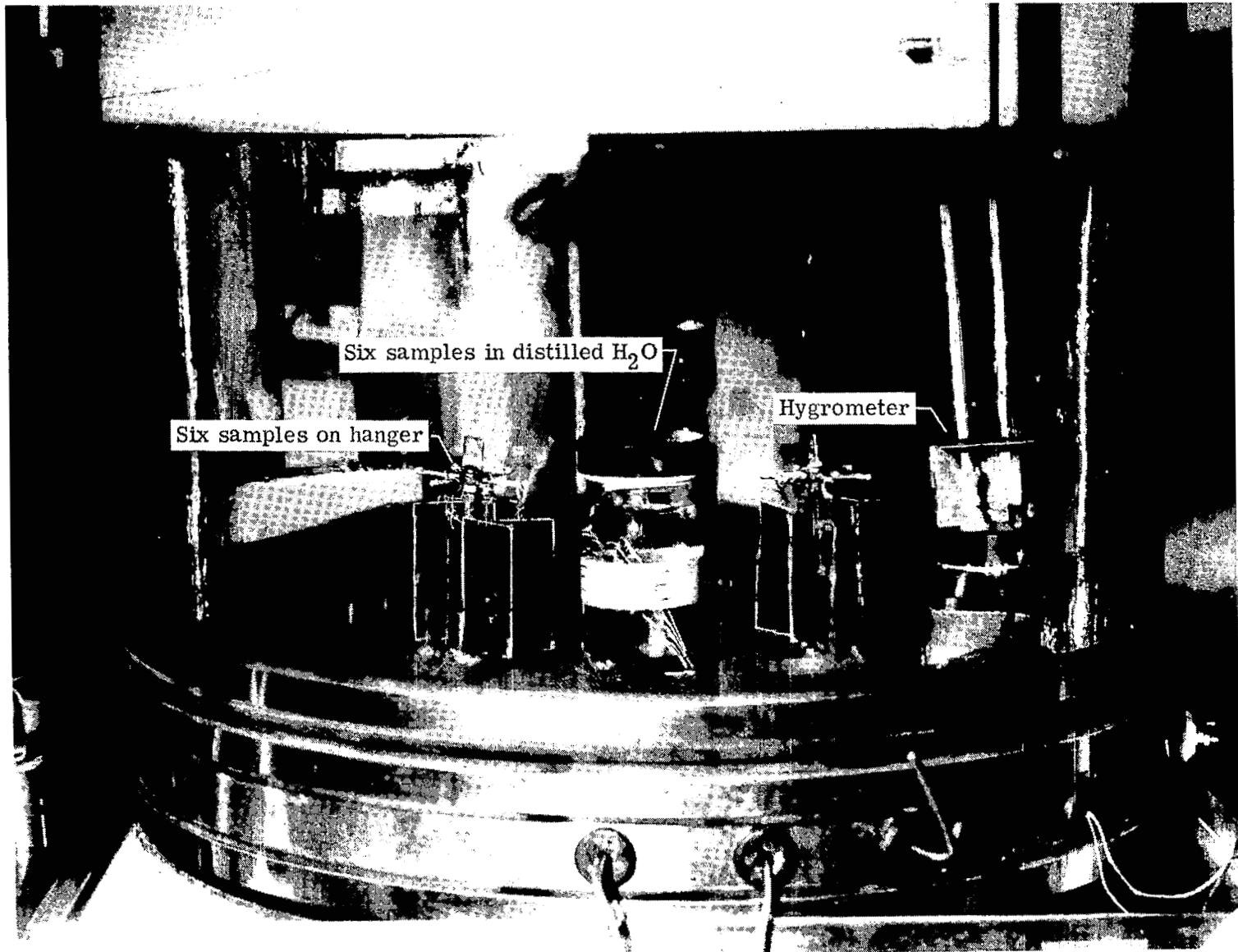

Figure 2.- Environmental chamber containing composite samples.

L-79-185

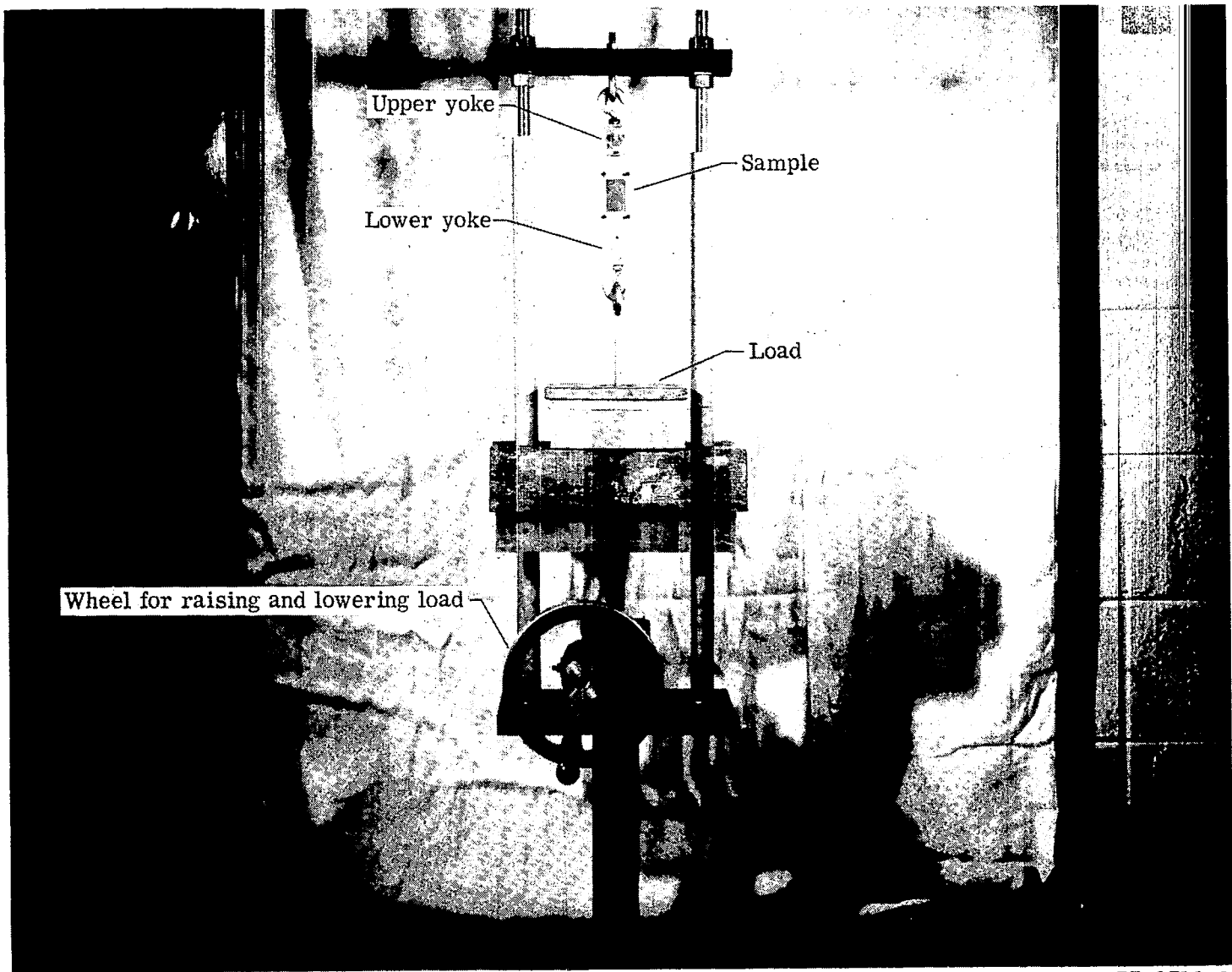

Figure 3.- Constant tension loading device.

L-77-8711.1

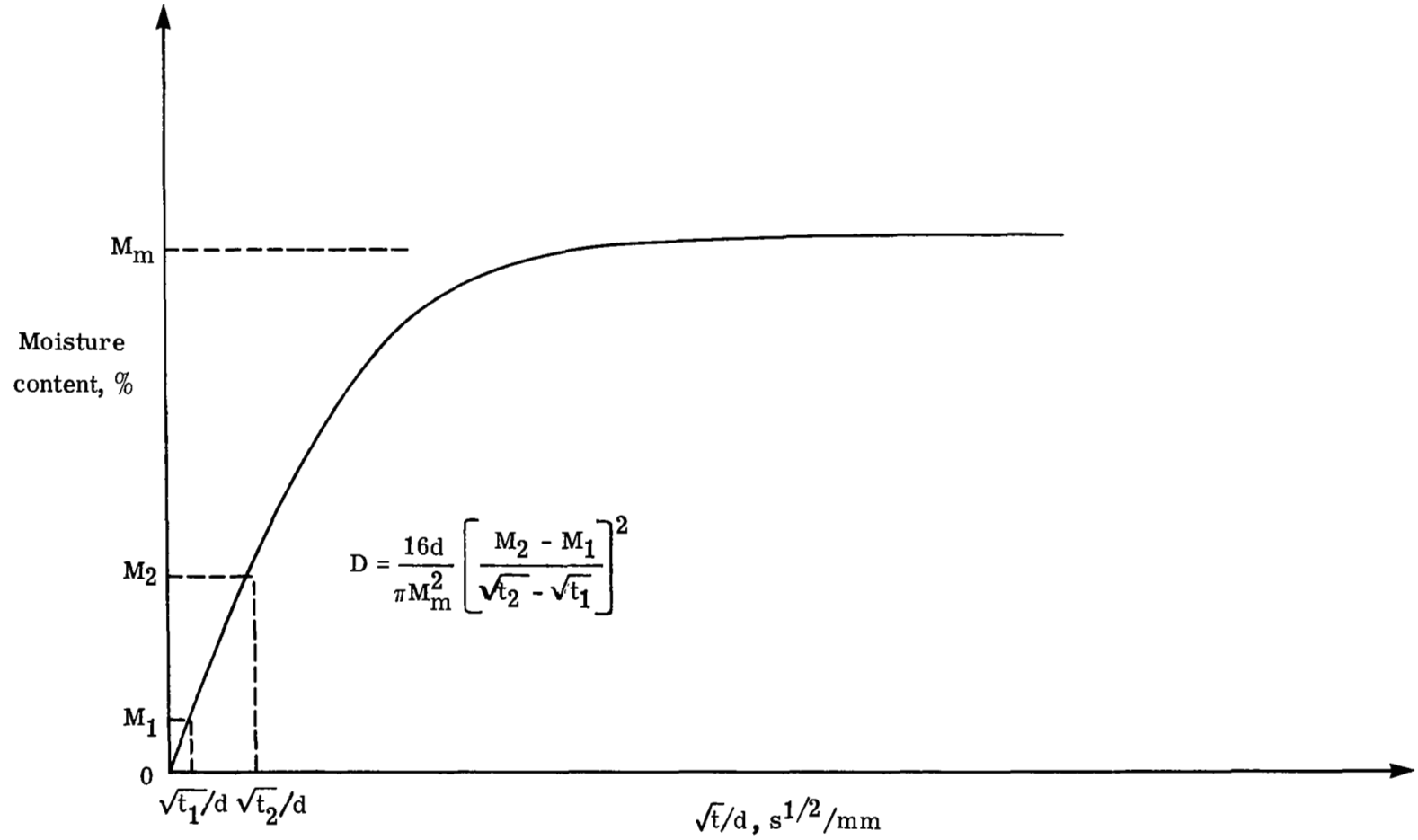

Figure 4.- Determination of diffusion coefficient from typical experimental absorption data.

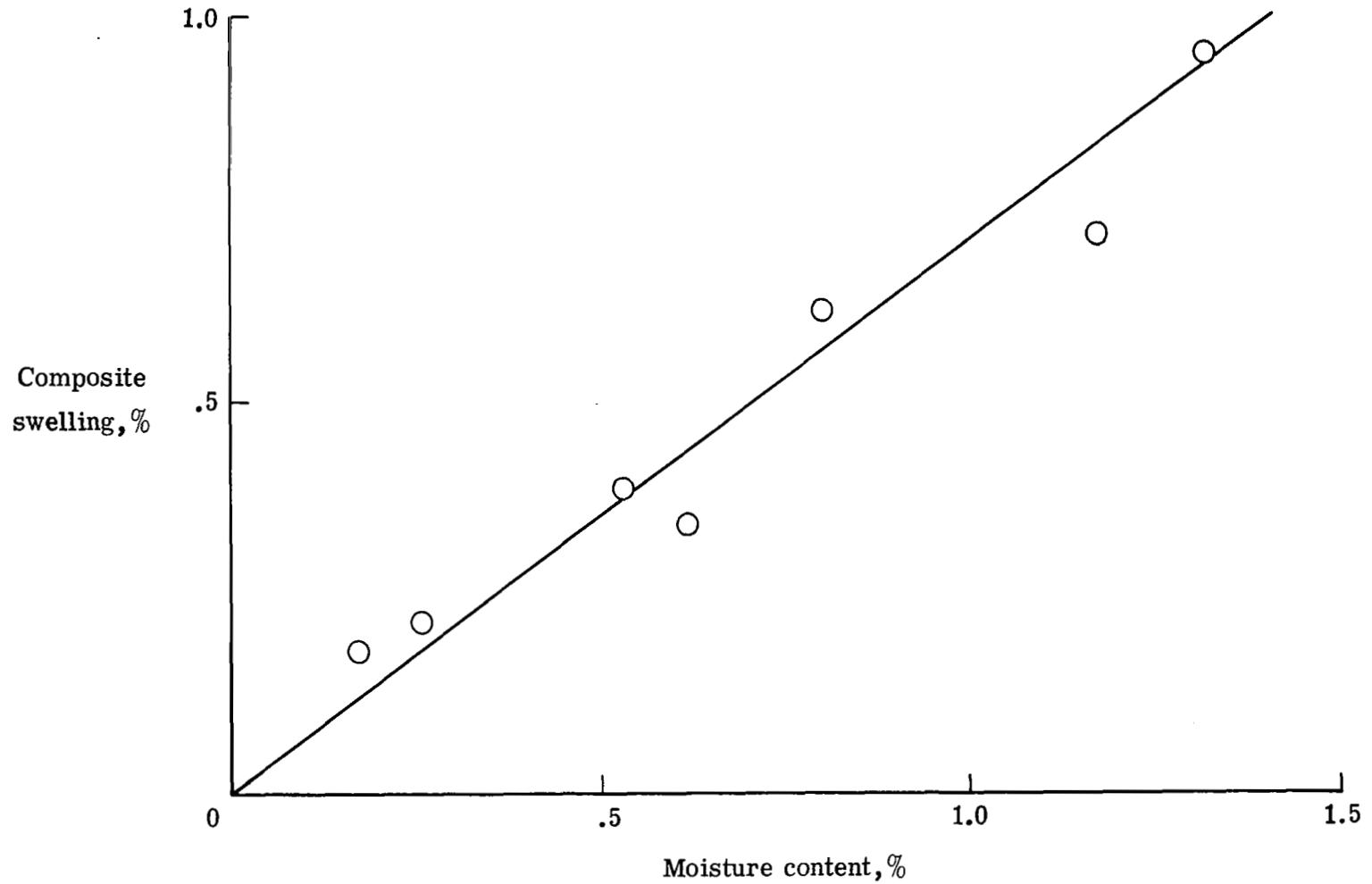

Figure 5.- Relation of swelling and moisture content for 24-ply unidirectional T300/5208 composites. Symbols are averages for 6 samples.

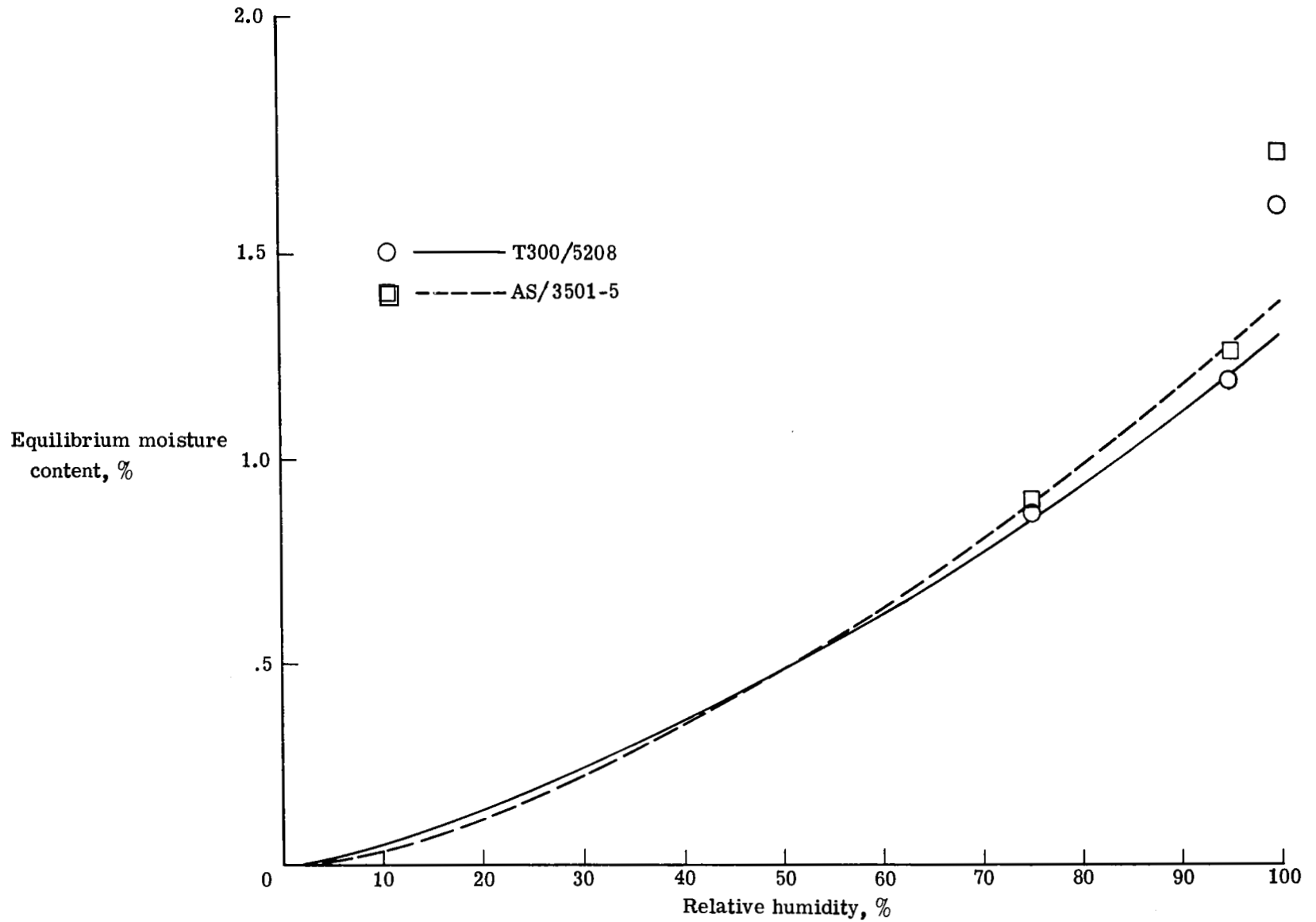

Figure 6.- Moisture content curves fitted to averages of experimental composite data at 322 K and 344 K.

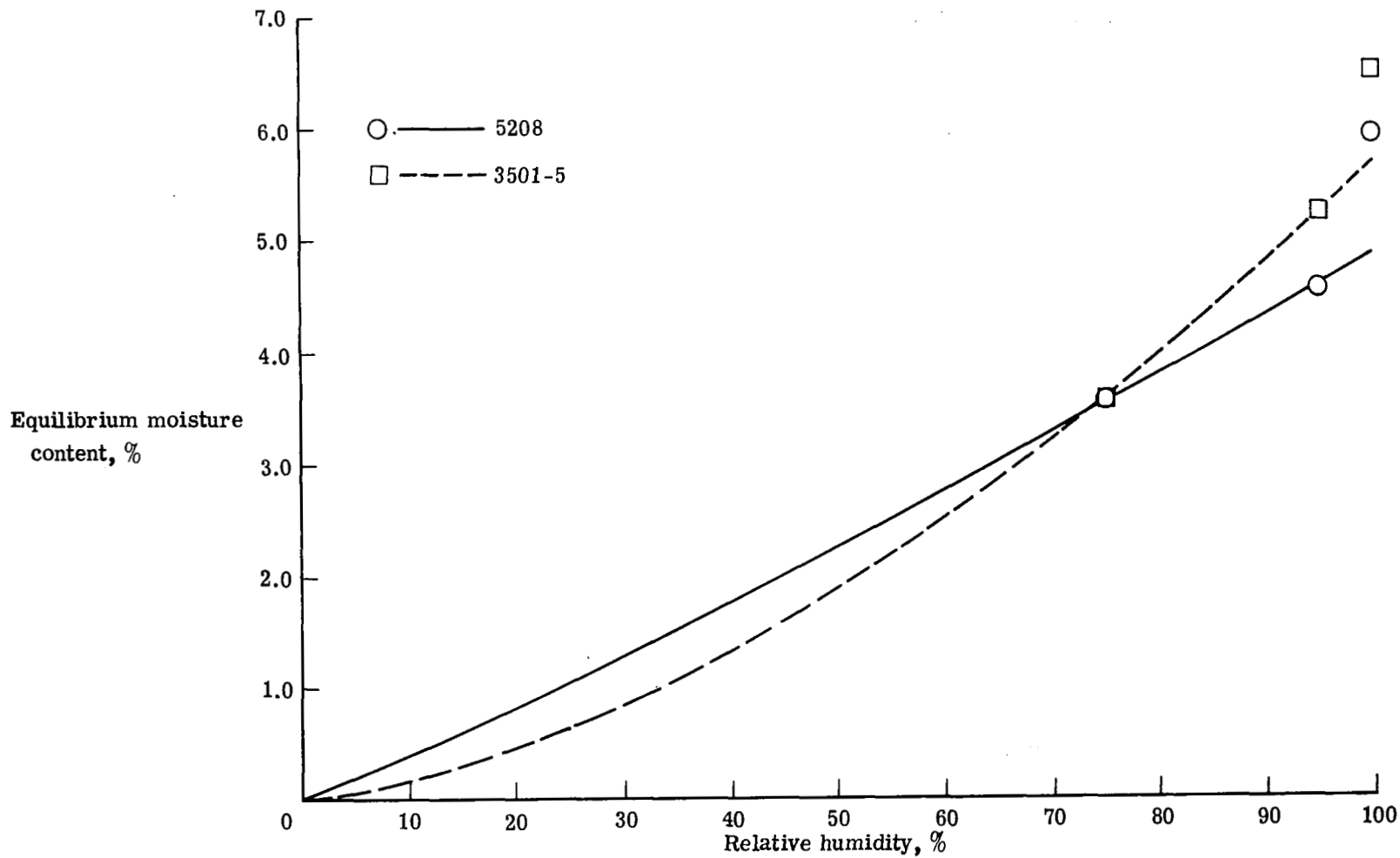

Figure 7.- Moisture content curves fitted to averages of experimental resin data at 322 K and 344 K.

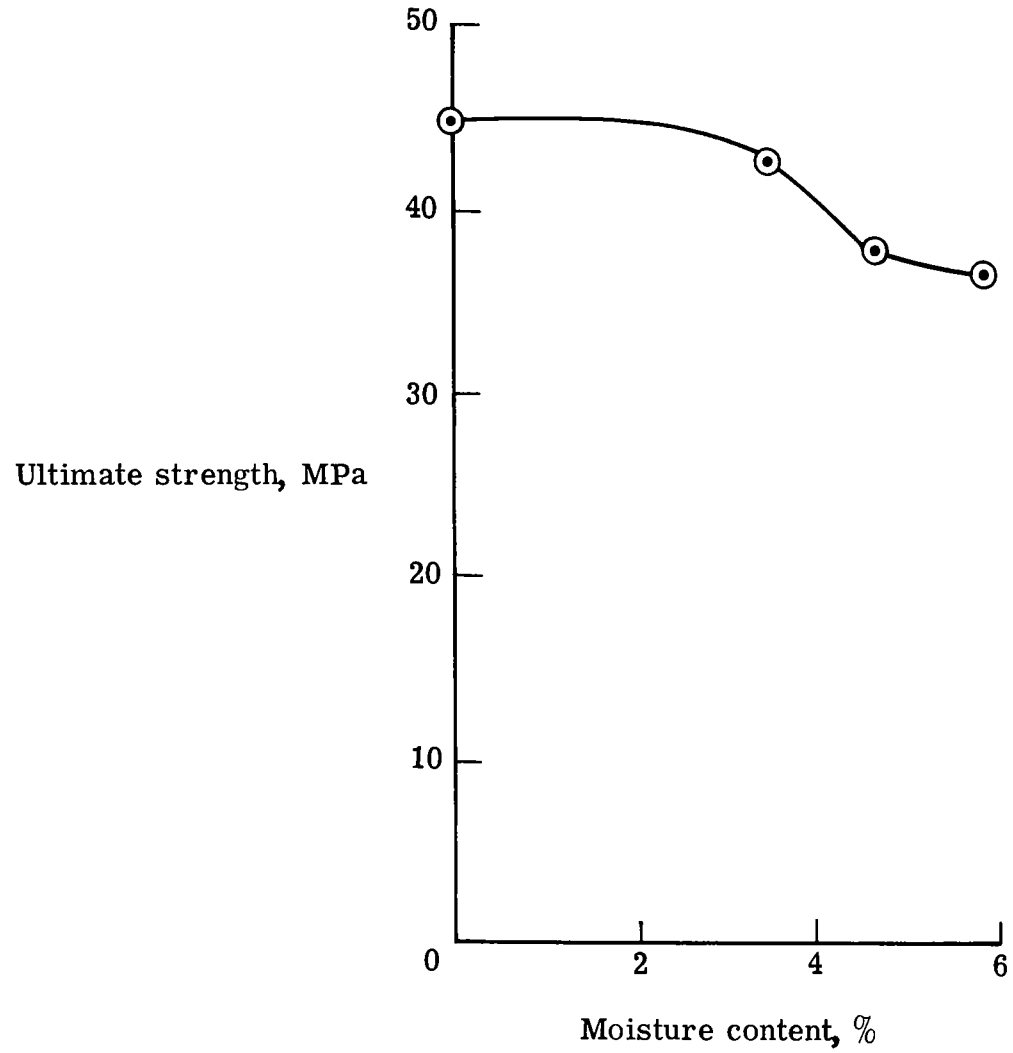

Figure 8.- Ultimate strengths of cured 5208 neat resin for four values of moisture content. $T = 344 \text{ K}$.

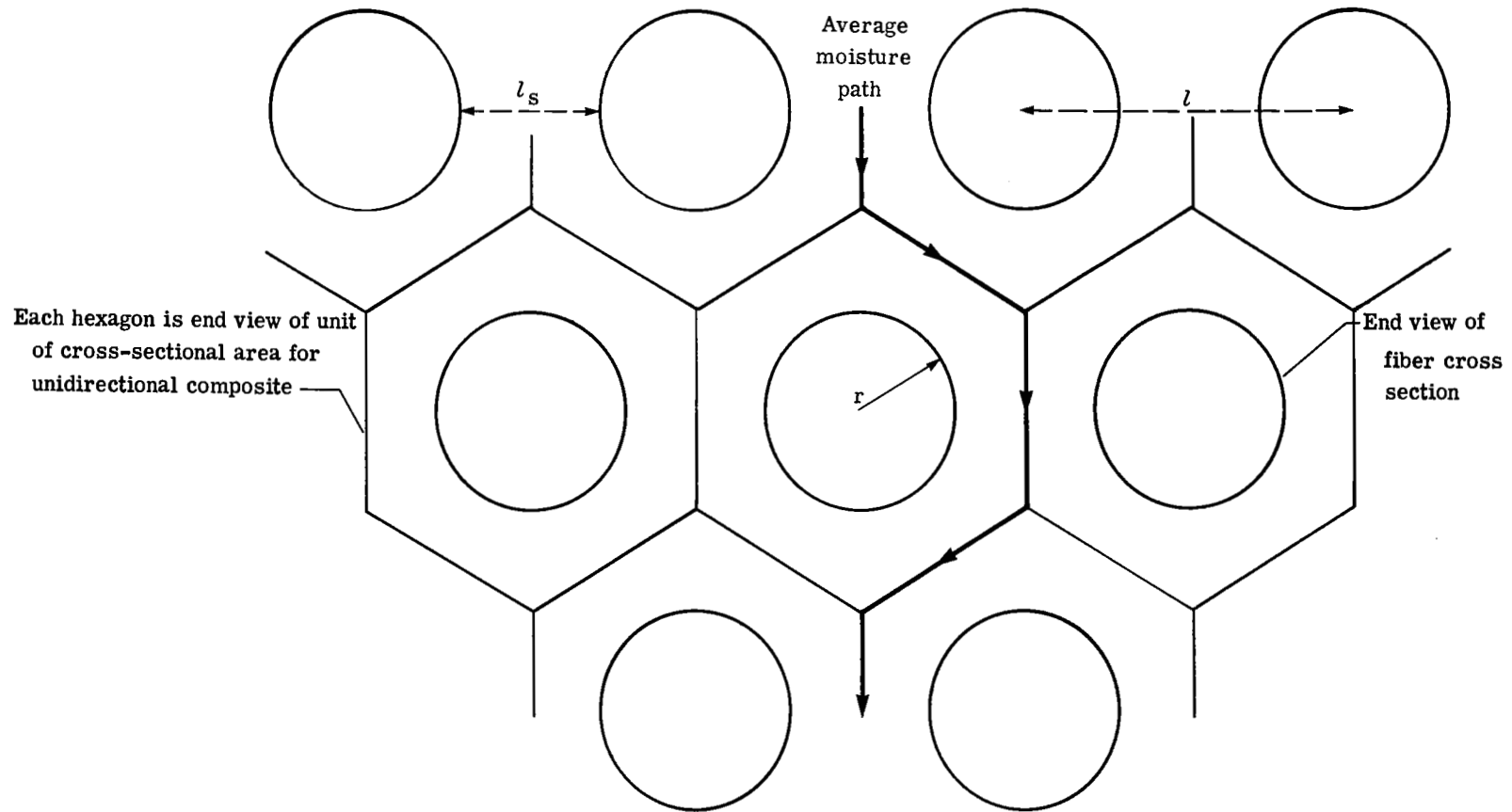

Figure 9.- End view of portion of an ideal unidirectional composite.

1. Report No. NASA TP-1474		2. Government Accession No.		3. Recipient's Catalog No.	
4. Title and Subtitle MOISTURE DIFFUSION PARAMETER CHARACTERISTICS FOR EPOXY COMPOSITES AND NEAT RESINS				5. Report Date August 1979	
				6. Performing Organization Code	
7. Author(s) Edward R. Long, Jr.				8. Performing Organization Report No. L-12629	
9. Performing Organization Name and Address NASA Langley Research Center Hampton, VA 23665				10. Work Unit No. 505-01-33-03	
				11. Contract or Grant No.	
12. Sponsoring Agency Name and Address National Aeronautics and Space Administration Washington, DC 20546				13. Type of Report and Period Covered Technical Paper	
				14. Sponsoring Agency Code	
15. Supplementary Notes					
16. Abstract <p>The moisture absorption characteristics of two graphite/epoxy composites and their corresponding cured neat resins have been studied in high humidity and water immersion environments at elevated temperatures. Moisture absorption parameters - such as equilibrium moisture content and diffusion coefficient - derived from data taken on samples exposed to high humidity and water soak environments were compared. Composite swelling in a water immersion environment was measured. Tensile strengths of cured neat resin were measured as a function of their equilibrium moisture content after exposure to different moisture environments. The effects of intermittent moderate tensile loads on the moisture absorption parameters of composite and cured neat resin samples were determined.</p>					
17. Key Words (Suggested by Author(s)) Cured neat resin Graphite/epoxy composites Moisture absorption Diffusion coefficient Moisture content Activation energy Mechanical properties			18. Distribution Statement Unclassified - Unlimited Subject Category 24		
19. Security Classif. (of this report) Unclassified	20. Security Classif. (of this page) Unclassified	21. No. of Pages 27	22. Price* \$4.50		

* For sale by the National Technical Information Service, Springfield, Virginia 22161

NASA-Langley, 1979