

NASA-TM-79221 19790021767

A Reproduced Copy

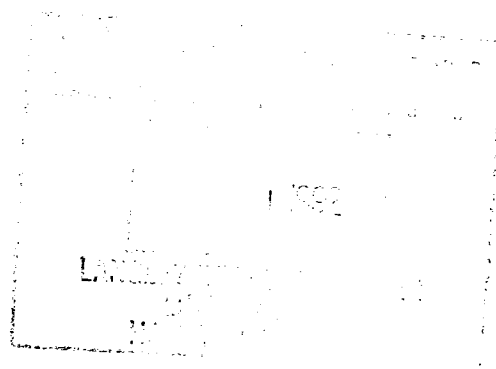

Reproduced for NASA
by the
Center for AeroSpace Information

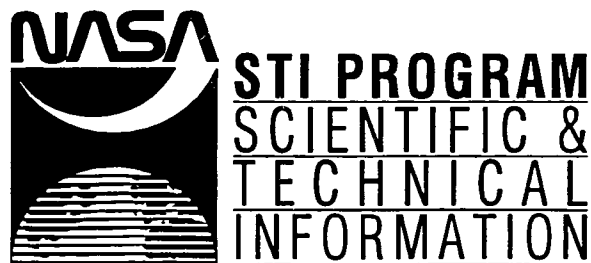

NF00515

BEST

AVAILABLE

COPY

NASA Technical Memorandum 79221

COMPUTERIZED SYSTEMS ANALYSIS AND
OPTIMIZATION OF AIRCRAFT ENGINE PER-
FORMANCE, WEIGHT, AND LIFE CYCLE COSTS

Laurence H. Fishbach
Lewis Research Center
Cleveland, Ohio

(NASA-TM-79221) COMPUTERIZED SYSTEMS
ANALYSIS AND OPTIMIZATION OF AIRCRAFT ENGINE
PERFORMANCE, WEIGHT, AND LIFE CYCLE COSTS
(NASA) 22 p HC A02/MP A01 CSCL 12B

N79-29938

G3/66 Unclas
31693

Prepared for the
Flight Mechanics Panel Symposium on the Use
of Computers as a Design Tool
sponsored by AGARD
Munich, Germany, September 3-6, 1979



N79-29938

COMPUTERIZED SYSTEMS ANALYSIS AND OPTIMIZATION OF AIRCRAFT
ENGINE PERFORMANCE, WEIGHT, AND LIFE CYCLE COSTS

by
Laurence H. Fishbach*
National Aeronautics and Space Administration
Lewis Research Center
Cleveland, Ohio
44135
USA

SUMMARY

E-112
Availability of a suitable propulsion system is generally acknowledged to be a key requirement for the successful development of a new airplane. This paper describes the computational techniques utilized at Lewis Research Center to determine the optimum propulsion systems for future aircraft applications and to identify system tradeoffs and technology requirements.

Over the last five years, the NASA Lewis Research Center has obtained a greatly increased capability of performing detailed studies of engine cycles on the computer. Many more parameters can now be accounted for in the engine selection process. We can calculate cycle performance, engine weight, predict costs and account for installation effects as opposed to fuel consumption alone. Almost any conceivable turbine engine cycle can be studied since we do not rely on preconfigured simulation codes but can input the engine cycle externally to the codes. Most of this capability has come through the joint efforts of the Naval Air Development Center, The Boeing Company and NASA Lewis.

These computer codes are:

NNEP - a very general cycle analysis code that can assemble an arbitrary matrix of fans, turbines, ducts, shafts, etc., into a complete gas turbine engine and compute on- and off-design thermodynamic performance

WATE - a preliminary design procedure for calculating engine weight using the component characteristics determined by NNEP

LIFCYC - a computer code presently being developed in conjunction with the Navy to calculate life cycle costs of engines based on the output from WATE

INSTAL - a computer code presently being developed under contract to calculate installation effects, inlet performance and inlet weight

POD DRG - a table look-up program to calculate wave and friction drag of nacelles

Examples will be given to illustrate how these computer techniques can be applied to analyze and optimize propulsion system fuel consumption, weight and cost for representative types of aircraft and missions.

INTRODUCTION

The airplanes, engines and missions of today are far more complicated than those of just a few years ago. The ability to determine the optimum combination of airplane and engine is of paramount importance. But what is the optimum combination. Is it the engine that burns the least fuel?; Costs the least to operate?; Can minimize installation penalties?; Minimizes fuel plus engine weight?; A combination of the above?

Each airplane/engine system probably has its own criteria of optimization. It is therefore necessary to develop the analytical tools capable of calculating all the factors which enter into the selection process. This paper discusses the computer techniques employed at the NASA Lewis Research Center to perform these calculations. The process by which almost any conceivable turbine engine can be evaluated as to fuel consumption, engine weight, cost and installation effects is described. Examples are shown as to the benefits of variable geometry and of the tradeoff of fuel burned versus engine weight. Future plans for further improvements in the analytical modeling of engine systems are also described.

HANDMATCHING

In order to determine engine operating characteristics at specified flight conditions, methods were developed in the 1940's for superimposing engine component matching maps for simple engines such as turbojets and turboprops. These methods involved laborious hand calculations and performance map transformations to determine at what operating conditions of the engine components continuity of mass and energy, and mechanical speed relationships were satisfied. Needless to say, especially when methods were developed for a two spool engine, hours and even days were required to determine an operating line for an engine. A thorough discussion of these methods can be found in reference 1. Figure 1 illustrates the time frame and capabilities that existed.

*Head, Flight Performance Section, Mission Analysis Branch, V/STOL and Noise Division.

EARLY COMPUTER BASED MATCHING CODES

With the advent of high speed computers, the task of matching of the engine components could not only be solved faster but more complex engines such as two-spool engines with a bypass flow (turbofan) could be simulated. Many companies, universities, and government installations developed computerized methods. One of the earliest of these matching computer codes was called SMOTE and was developed at Wright Patterson Air Force Base (ref. 2). SMOTE was capable of matching two spool turbofan engines. This capability was expanded by the development of GENENG and GENENG II at NASA's Lewis Research Center. The GENENG codes (refs. 3 and 4) were capable of matching one, two or three spool engines with as many as three nozzles. Turbofans with booster or supercharger stages on the compressors could be simulated as well as aft-fan engines. GENENG served as the main simulation code in NASA and was adopted for use by over 20 Government agencies, companies, and universities. A version of GENENG called DYNGEN was developed at Lewis to simulate transient behavior of turbofan engines (ref. 5) for use in control system studies.

THE NAVY/NASA ENGINE PROGRAM (NNEP)

Since 1973, the NASA Lewis Research Center has been conducting studies of advanced supersonic engines including Variable Cycle Engines or VCE's. These engines take advantage of the use of variable geometry components and in-flight flow switching capabilities such as from mixed flow to separate flow to attempt to deliver good engine performance at supersonic conditions as well as subsonic. By optimizing the exhaust profile during take-off significant decreases in jet noise can also be achieved. It became apparent that GENENG and similar codes could not simulate some of the concepts coming out of the studies. The new cycles did not fit into any of the engine concepts already built into the codes.

Two options were available. A new specific code could be developed for each new engine concept, or a general code capable of simulating any engine could be developed. The second alternative was chosen as being more time efficient in the long run and more responsive to any immediate need. We, therefore, decided to develop a new computer code in which an arbitrary engine configuration consisting of selected combinations of components could be described at input time. It was also necessary to allow changes in engine configuration while running the code to simulate the operation of various VCE concepts. Furthermore, because of the large number of variables, it was highly desirable to optimize the settings of variable components such as nozzle or turbine areas (e.g., to minimize SFC for a given thrust).

Contact with the Naval Air Development Center, Warminster, PA, revealed that they had a computer code, NEPCOMP (ref. 6), which already contained some of the features desired and whose structure was flexible enough to permit the addition of others. This code lacked optimization capability and the ability to operate with "stacked" maps which would represent variable component performance. However, it already had the capability for processing arbitrary engine configurations. NASA-Lewis therefore contracted with the Naval Air Development Center for the joint development of an improved computer code. The objective of the joint effort was to obtain a code capable of: simulating any turbine engine the user could conceive, simulating variable component performance, changing airflow paths while running, and optimizing variable-geometry settings to minimize the specific fuel consumption or maximize the thrust.

An interim version of this new code given the acronym NNEP (Navy NASA Engine Program) became operational in May of 1974 and has been continuously refined since then to include all of the desired capabilities.

NNEP contains almost all of the subroutines and incorporates the philosophy of construction of NEPCOMP as described in reference 6. The major improvements incorporated in NNEP relative to NEPCOMP are the addition of: (1) a performance optimization capability, (2) processing of stacked component maps for VCE operation, (3) multiconfiguration (modes) to simulate flowpath switching, (4) a computer generated engine configuration schematic, (5) throttle dependent inlet and boattail drag calculations, and (6) a simpler input data format.

As previously mentioned, the engine is configured at input time in running NNEP. First, the user draws a schematic of the engine he wishes to study, for example, a simple turbofan as shown in figure 2. He assigns a flow station number 1 at the entrance to the inlet and labels the inlet as component number 1. After this he is free to assign any number at the other flow stations in the engine and to label each of the components with any component number. One problem that does arise is that is not possible at all times to label the flow stations in accordance with the Aerospace Recommended Practice ARP 755A.

The components that can be simulated in NNEP are as follows:

Flow components - falling under this classification are

- (1) Inlets
- (2) Ducts/burners
- (3) Compressors

ORIGINAL PAGE IS
OF POOR QUALITY

- (4) Turbines
- (5) Mixers
- (6) Heat exchangers
- (7) Splitters
- (8) Nozzles
- (9) Water injectors

Mechanical components -

- (1) Shafts
- (2) Loads

Control and optimization components -

- (1) Controls
- (2) Optimization variables
- (3) Limit variables

There is a limit of a total of 60 components (including all of the flow, mechanical, control and optimization variables) allowed within the code. The maximum number of any one type of flow or mechanical components is 24 and the maximum number of controls + optimization variables is 20. A KONFIG input card is then generated by the user for each component as shown in figure 3. This figure is for the compressor in figure 2. The component is identified as component number 4, that it is a compressor and that its primary upstream flow station number is 4, there is no secondary upstream flow; that the primary downstream flow station is number 5; and the secondary downstream flow station is number 13 (bleed flow). After all the components have been "configured," NNEP generates its own flow path logic by joining components by the station numbers.

Each component has associated with it up to 15 required inputs describing the component. These inputs are usually design values such as pressure rise or map numbers corresponding to prestored performance maps for the component. An illustration of the specifications for the compressor in figure 3 is shown in figure 4.

Control information is also entered as input identifying both the independent and dependent variable as shown in figure 5. Optimization variables are entered similarly as shown in figure 6.

NNEP has proven to be a powerful analytical tool. Its primary purpose is to generate engine performance data for mission analysis studies. A typical use is shown in figure 7. This figure illustrates the specific fuel consumption of a supersonic turbofan engine as a function of engine thrust when the supersonic engine is operated at a subsonic cruise condition Mach 0.9 at 11 000 meters (36 089 ft). Shown on the figure are three curves. The bottom curve represents the engine performance on an uninstalled basis, that is, a pure thermodynamic cycle calculation. None of the variable-geometry features of the engine have been utilized.

An engine and inlet which are sized for supersonic cruise can suffer significant installation losses subsonically. At the reduced power settings the inlet will be capable of swallowing more air than the engine requires resulting in inlet spillage drag. The boattail aft of the engine will not be filled with engine air resulting in additional drag. Installed performance for the fixed-geometry engine is represented by the uppermost curve. As can be seen the difference between installed and uninstalled performance increases as engine thrust is reduced. The engine specific fuel consumption increases rapidly at the lower power settings.

The introduction of variable geometry features into the engine can greatly change the shape of the installed performance curve. The performance of the engine with a variable geometry nozzle and variable area low pressure turbine is shown on the remaining curve. The optimization capability of NNEP has been used to determine the optimum values of the two independent variables. As can be seen, the curve is essentially flat. The components have varied to maintain as high an airflow as possible through the engine to reduce the spillage and boattail drag. NNEP has proven to be a very versatile engine cycle computer code and is now in use at approximately 30 government installations, companies and universities.

WEIGHT ANALYSIS OF TURBINE ENGINES - WATE

With NNEP we are capable of simulating almost any turbine engine cycle the user can conceive of. Being able to calculate engine performance and hence the fuel consumed on a mission is an important part of calculating the vehicle performance. It is also necessary to be able to calculate the engine weight, length and diameter. The engine weight represents a significant part of the empty weight of an airplane. The length and diameter of the engine are important in calculating friction and boattail drags. In order to

develop the capability, NASA Lewis awarded a contract to the Boeing Military Airplane Development Division of the Boeing Company to develop an engine weight estimation code.

The first version of this code WATE-1 (ref. 8) was completed in 1977. It used a preliminary design approach where stress level, maximum temperature, material, geometry, stage loading, hub-tip ratio and shaft mechanical overspeed are used to determine individual component weights. The total engine weight was then calculated as the sum of the individual components. The contract required that the code predict both individual component and total engine weight within ± 10 percent accuracy.

A relatively high level of detail was found necessary in order to obtain the required accuracy. Component weight data for 29 different engines were used as a data base. This data base is shown in the figure 8. The list of engines includes military and commercial, turboprops and turbojets, augmented and dry, hardware engines and proposed engines, and supersonic and subsonic engines.

WATE 1 was constructed to operate as an adjunct to NNEP. After running a cycle point on NNEP the thermodynamic properties were fed to the WATE-1 set of subroutines along with inputs representing the design features of the components. The engine weight, length, and dimensions were then calculated. At the same time, parts counts are generated for the engine such as number of blades, size of discs, etc.

In 1978, NASA Lewis awarded a follow-on contract to the Boeing Company to extend the capabilities of WATE 1. This new version, WATE 2 (ref. 9) was completed in 1979 and has added many desirable features. Weight determination is done for each component at its critical operating point as follows: NNEP is now used to "fly" the engine throughout the flight envelope of the aircraft and the maximum values of the flow, temperature, pressure and engine speed stored for use in sizing the components. Based upon these critical conditions, the weight is determined. The capability to calculate the weight of radial flow components and of small engines was added in conjunction with a subcontract to the Garrett Division of AIResearch Manufacturing Company of Arizona. The engine center of gravity and moments of inertia are also now calculated.

The accuracy of the code is shown in figure 9. As can be seen, all of the engines fall within the ± 10 percent band and, in most cases, approach ± 5 percent or better especially in terms of engine weight.

WATE has built-in default values for most of the inputs. If the user does not enter values, these default values are automatically used. Many of these were used in the calculation of these weights. If more information was available to us, especially in terms of geometry inputs of the rotating components, these already small errors could probably be reduced even further.

The combination of WATE and NNEP is a very powerful analytical tool. As an example, a recent study considered the question of optimum cycle parameters for a duct burning turbofan for a supersonic cruise airplane (ref. 10). Some of the results of this study are duplicated here. The fuel mass and bare engine mass for 88 950 newton (20 000 lb) thrust engines flying 6440 kilometers (4000 mile) operating at Mach 2.4, 16460 meters (54 000 ft) initial altitude are shown in figure 10. These masses are shown as functions of Bypass Ratio and Overall Pressure Ratio (OPR) with and without duct burning. The cycle analyst looking only at the fuel mass in figure 10 would conclude that the optimum engine would operate dry and have an OPR of about 16 at a Bypass Ratio of 1.8 or more. However, when the mission analyst adds the fuel and engine masses as shown in figure 11, the optimum engine operates with the ductburner on, an OPR of 12 and a BPR of 0.8.

LIFE CYCLE COSTING - COST/LIPCYC

The question of cost is entering more and more into the selection process for optimum engines. The initial cost is not the only criteria for selection. Total life cycle cost including maintenance, spares, operating costs, etc. must be considered for many applications. In order to develop the capability of calculating Life Cycle Cost, NASA Lewis contracted with the Naval Air Development Center (NADC) in 1978 to receive their costing model. NADC in turn subcontracted with Boeing to supply them with the production cost of the engine. As previously mentioned the weight code WATE calculates parts counts and weights as well as total component and total engine weight. These weights are transferred to cost estimating routines which are based on correlations developed by NADC and Naval Air Systems Command. This procedure is flow diagramed in figure 12. The correlation parameter is based on a system of classifying materials by similarity of applications in engines (ref. 11). In this procedure, materials used in jet engines are placed in one of a total of six relative cost categories having to do with a combination of manufacturing cost and raw materials cost. Carbon steel and aluminum are assigned the lowest classification and used as a reference. High-strength high-temperature nickel cobalt alloys which are costly and difficult to machine are placed in the highest (fifth) classification. Because of peculiar differences in cost and machinability, titanium alloys are assigned a separate (sixth) classification. Two induces are developed for each material class, namely

- (1) Relative material cost
- (2) Relative machining cost

The product of these two induces is called the "relative weighing factor."

In the cost estimation procedure, the estimated weight of each engine component is first converted to raw material weight. A raw material weight to finished material weight scaling factor, referred to as "Buy/Fly" ratio, has been estimated for each component for state-of-the-art and for advanced production methods. Raw material weight is then multiplied by the relative weighing factor, and the sum of all such component products is formed. The summation for all engine components is called the "Maurer factor" in honor of its originator, R. J. Maurer. The production cost of the engine is estimated by the linear correlation (fig. 13) between engine manufacturing cost and the Maurer factor (ref. 11).

This code is just becoming operational at NASA Lewis and no results have as yet been generated except for isolated check cases in which predicted costs have been compared to the actual and appear reasonable. A final report should be published sometime during the summer of 1979.

Having determined the engine cost, it is now possible to determine the Life Cycle Cost based upon the NADC Life Cycle Costing Model. The interrelationship of COST with LIFCYC is shown in figure 14. NADC will supply the inputs and models to calculate all the parts of the pie other than manufacturing costs. It is anticipated that this work will be performed in the fall of 1979.

IMPROVED INSTALLATION EFFECTS MODEL - INSTAL

The previous example (fig. 7) of varying engine flow by the use of variable geometry to reduce installation effects showed the importance of inlet and nozzle component performance, external as well as internal. That figure was generated with a simplified model for inlet and boattail drag that is built into the WNEP program.

It was decided that NASA Lewis should obtain a more sophisticated method for these calculations. Consequently, a contract was awarded to Boeing in 1978 to provide a broad subsidiary program for determining power-dependent inlet and afterbody installation effects and also inlet/nacelle weights (presently not in the WATE code). Nozzle weights are already calculated within WATE. In addition to generating the component performance maps for WNEP, the code can be interactive with the cycle and hence a tradeoff of inlet, afterbody, and cycle can be utilized in the design process.

The types of performance maps to be generated are shown in figures 15 and 16 for inlets and nozzles respectively. The necessary maps are obtained from either a data base or theoretical calculations (ref. 13). The data base contains performance data (usually experimental) for a spectrum of inlet (axisymmetric, 2D, pivot, mixed compression) or nozzle (axisymmetric, 2D, twin, etc.) types. A derivative procedure (ref. 13) can be used to adjust the data base for changes in design Mach number, sideplate shape, subsonic diffuser loss, cowl lip bluntness, takeoff door area, external cowl initial angle, bleed system design, and bypass system exit design. Items not included in the data are determined analytically. Nozzle/afterbody data are treated in a similar manner. The data base, being primarily experimental, offers increased confidence in areas that are difficult to treat theoretically such as viscous effects.

After selecting the inlet size or sizing Mach number, the inlet and nozzle are matched to the WNEP cycle data and the installed performance calculated as well as the respective weights. Trade off studies can now be made of such effects as the best combination of bypass and spillage for minimum specific fuel consumption.

The final report for the work being performed under this study contract is scheduled to be published in the early fall of 1979.

WAVE AND FRICTION DRAG - PODDRG

Under contract to NASA Langley Research Center, Rockwell International developed a method of evaluating the effects of nacelle shape on drag and weight of a supersonic cruising aircraft (ref. 14). Under this contract, Rockwell determined wave and friction drag increments for a range of parametric shapes. As part of a follow-on contract with NASA Lewis Research Center, Rockwell developed a computer code (PODDRG) capable of interrogating the data points generated under the previous contract in order to determine drag increments for any nacelle shape of interest (ref. 15).

These nacelle incremental drags are only applicable to the NASA arrow-wing supersonic transport configuration (ref. 16). The program yields the incremental wave and friction drags of nacelles as functions of nacelle geometry variables and airplane Mach number. The drag increments are for the total vehicle relative to the vehicle with nacelles removed. That is, all interference effects with the airframe are accounted for. The nacelle shape parameters used as inputs to the program are:

- (1) A_c Inlet capture area
- (2) A_{MAX} Nacelle maximum cross-sectional area
- (3) A_n Nozzle exit area (supersonic cruise position)
- (4) X_{MAX} Distance from inlet cowl leading edge to maximum cross-sectional area

- (5) l Nacelle total length
- (6) S_{REP} Reference wing area

The output of this program includes, for the nacelle of interest:

- (1) The aforementioned input data
- (2) Drag coefficients at Mach 1.2, Mach 2.2, and the input Mach number for friction (CDF), wave (CDW), and total (CDT) drag
- (3) The nondimensional parameters of position of maximum cross-sectional area (X_{MAX}/l), nozzle-to-capture area ratio (A_n/A_c), maximum-to-capture area ratio (A_{MAX}/A_c), and fineness ratio (l/r_n).

In addition, incremental drag coefficients of the reference airplane nacelle (ref. 16) are printed.

Typical nacelle incremental wave drag variations are shown in figure 17. Note that a properly shaped nacelle can produce a lower total airplane drag than that of the airframe alone ($\Delta C_{Dw} < 0$). The nacelle drag thus calculated are fed into mission flight computer codes in evaluating systems performance.

CONCLUDING REMARKS

NASA Lewis Research Center with a combination of in-house, joint, and contracted efforts has been and is continuing to develop the capability to determine the engines for optimum mission performance. In the selection process we can account for cycle performance, engine weight, life cycle costs, and installation effects. Future efforts will be directed towards improvement in the current capabilities, mainly in the areas of developing better optimization methods to reduce computer time and analytically determining performance maps for rotating machinery. For example, we are about to award a contract for turbine map generation, to be used for new cycles in which simple scaling of pre-existing maps is not sufficient. We believe that all of these methods will greatly reduce the effort expended in performing mission analysis by narrowing in more quickly on the engine cycles of greatest interest.

REFERENCES

1. Dugan, James P., Jr.: Compressor and Turbine Matching, in Aerodynamic Design of Axial-Flow Compressors, NASA SP-36, 1965, pp. 469-484.
2. McKinney, John S.: Simulation of Turbofan Engine. Part I. Description of Method and Balancing Technique. AFAPL-TR-67-125, pt. 1, Air Force Aero Propulsion Lab., Wright-Patterson AFB, Ohio, Nov. 1967. (Available from DDC as AF-325197.) Part II. User's Manual and Computer Program Listing. AFAPL-TR-67-125, pt. 2, Air Force Aero Propulsion Lab., Wright-Patterson AFB, Ohio, Nov. 1967. (Available from DDC as AD-825198.)
3. Koenig, Robert W.; and Fishbach, Laurence H.: GENEND: A Program for Calculating Design and Off-Design Performance for Turbojet and Turbofan Engines. NASA TN D-6552, 1972.
4. Fishbach, Laurence H.; and Koenig, Robert W.: GENEND 2: A Program for Calculating Design and Off-Design Performance of Two- and Three-Spool Turbofans with as Many as Three Nozzles. NASA TN D-6553, 1972.
5. Sellers, James P.; and Daniele, Carl J.: DYNGEN - A Program for Calculating Steady State and Transient Performance of Turbojet and Turbofan Engines. NASA TN D-7901, 1975.
6. Shapiro, S. R.; and Caddy, M. J.: NEPCOMP - The Navy Engine Performance Program. ASME Paper 74-GT-83, Mar. 1974.
7. Fishbach, Laurence H.; and Caddy, Michael J.: NNEP - The NAVY-NASA Engine Program. NASA TM X-71857, 1975.
8. Pera, R. J.; Onat, E.; Prewitt, N. L.; Klees, G. W.; and Tjonneland, E.: A Method to Estimate Weight and Dimensions of Aircraft Gas Turbine Engines. Volume I, Method of Analysis. Volume II, User's Manual. Volume III, Programmer's Manual. D6-44258-Vol. 1, Vol. 2, Vol. 3, Boeing Co., Seattle, Wash., May 1977. NASA CR-135170, Vol. I, NASA CR-135171, Vol. II, and NASA CR-135172, Vol. III, 1977.
9. Onat, E.; and Klees, G. W.: A Method to Estimate Weight and Dimensions of Large and Small Gas Turbine Engines. Boeing Military Airplane Development, Seattle, Wash., Jan. 1979., NASA CR-159481, 1979.
10. Fishbach, Laurence H.; Preliminary Study of Optimum Ductburning Turbofan Engine Cycle Design Parameters for Supersonic Cruising. NASA TM-79047, 1978.

ORIGINAL PAGE IS
OF POOR QUALITY

11. Brennan, T. J.; Taylor, R. N.; and Steinert, A. G.: Cost Estimating Techniques for Advanced Technology Engines. SAE Paper 700271, Apr. 1970.
12. Sharp, B. M.; and Howe, J. P.: Procedures for Estimating Inlet External and Internal Performance. McDonnell Aircraft Co., St. Louis, Mo., Apr. 1974, Naval Weapons Center, NWC-TF-5555, 1974.
13. Ball, W. H.; et al.: Rapid Evaluation of Propulsion System Effects, Vol. 1: Final Report; Vol. 2: PIPSI User's Manual; Vol. 3: Derivative Procedure (DERIV?) User's Manual; Vol. 4: Library of Configurations and Performance Maps. Boeing Aerospace Co., Seattle, Wash., July 1978. AFFDL-TR-78-91-Vol.1-4, Wright-Patterson AFB, Ohio, 1978. (AD-B031629L, V.1; AD-B031766L, V.2; AD-B031768L, V.3; AD-B031555L, V.4.)
14. Bonner, E.; Mairs, R. Y.; and Tyson, R. M.: Effects of Nacelle Shape on Drag and Weight of a Supersonic Cruising Aircraft. Rockwell International Corp., Los Angeles, Calif., Oct. 1975. NASA CR-144893, 1975.
15. Tyson, Ray M.; Mairs, R. Y.; Halferty, P. D., Jr.; Moore, B. E.; and Chaloff, D.: Methods for Comparative Evaluation of Propulsion System Designs for Supersonic Aircraft. NA-76-470, Rockwell International Corp., Los Angeles, Calif., June 1976. NASA CR-135110, 1976.
16. Advanced Supersonic Technology Concept Study Reference Characteristics. LTV Aerospace Corp., Hampton, Va., Dec. 1973. NASA CR-132374, 1973.

E-112

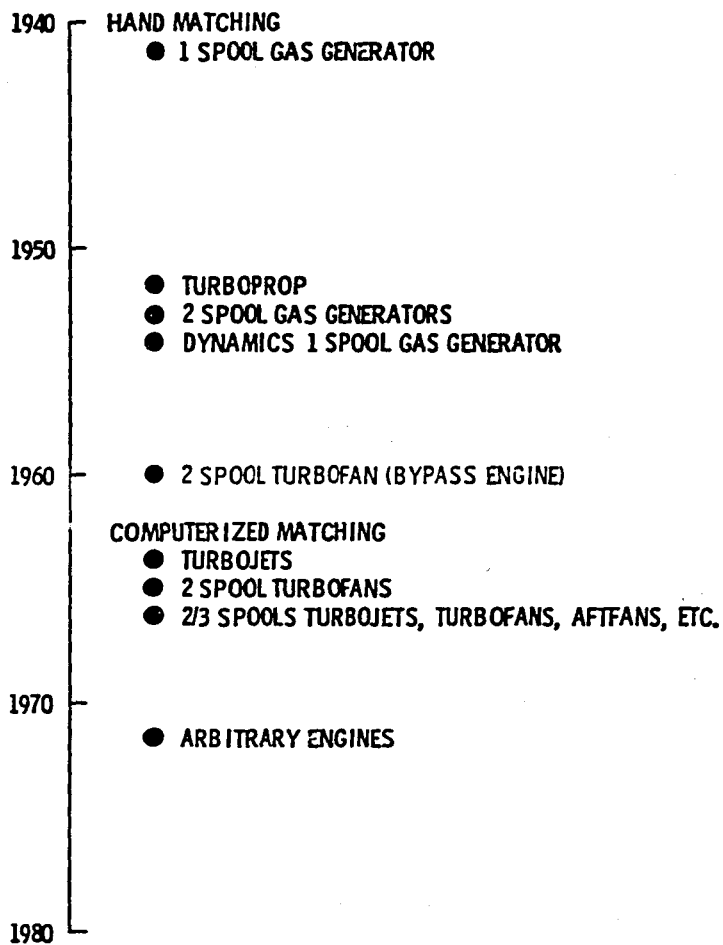

Figure 1. - Approximate history of methods of matching turbine engines.

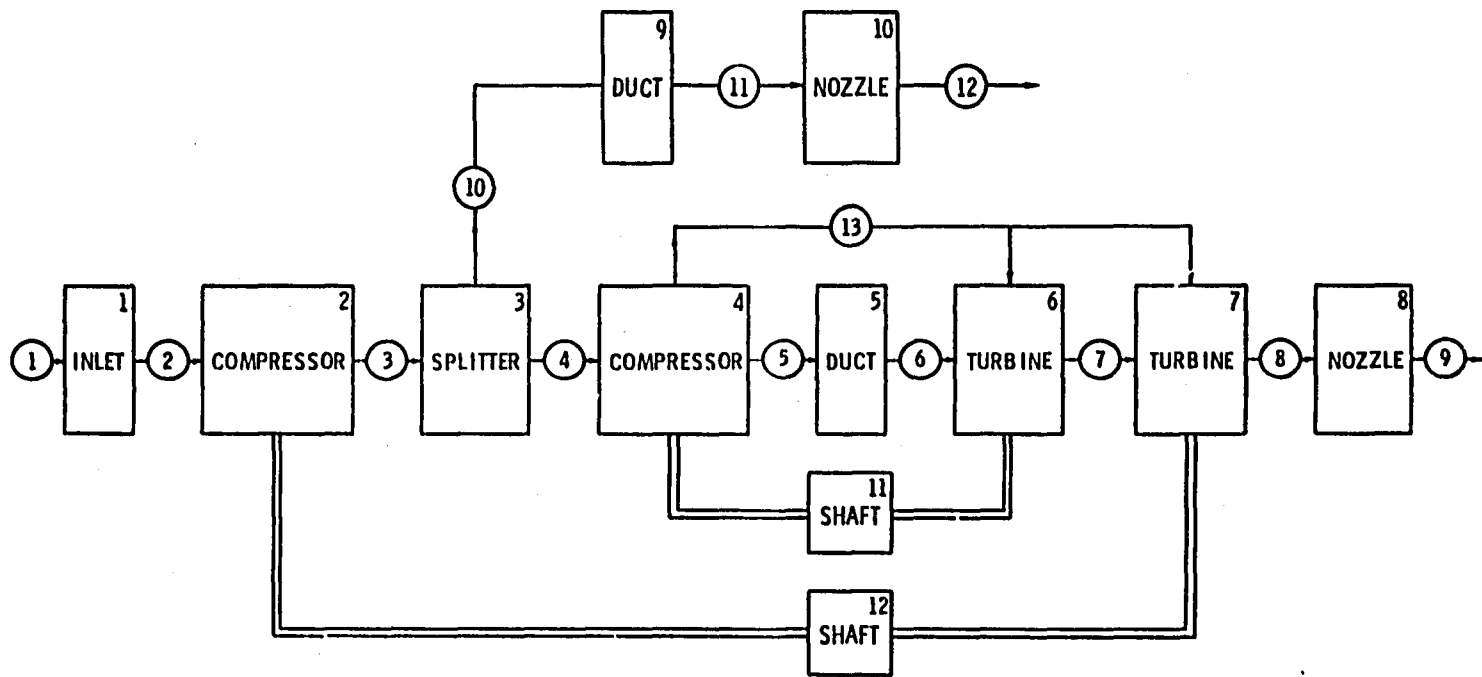
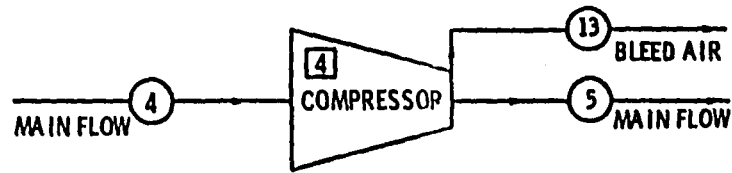

Figure 2. - Simple 2 spool turbofan with cooled turbines.



KONFIG (1, 4) = 'COMP', 4, 0, 5, 13

COMPONENT #
TYPE
PRIMARY UPSTREAM
SECONDARY UPSTREAM
PRIMARY DOWNSTREAM
SECONDARY DOWNSTREAM

FLOW STATION NUMBERS

Figure 3. - Define component type and location in flowstream.

SPEC (1, 4) = 1.1, 0.036, 1, 3707, 1, 3708, 1, 3709, 1, 0, 0, 0.88, 4.1, 1.0, 0,
(1) (2) (3) (4) (5) (6) (7) (8) (9) (10) (11) (12) (13) (14) (15)

- (1) "R" VALUE ON MAP = 1.1
- (2) BLEED FLOW/TOTAL FLOW = 0.036
- (3), (5), (7), AND (9) SCALE FACTORS ON $N/\sqrt{\theta}$, $W\sqrt{\theta}/\delta$, η , AND PR ON MAPS. THESE ARE INITIALLY SET = 1 AND ARE INTERNALLY COMPUTED
- (4) MAP REFERENCE NUMBER OF $W\sqrt{\theta}/\delta$ VERSUS "R" = 3707
- (6) MAP REFERENCE NUMBER OF η VERSUS "R" = 3708
- (8) MAP REFERENCE NUMBER OF PR VERSUS "R" = 3709
- (10) 3rd DIMENSIONAL ARGUMENT ON "STACKED MAPS" = STATOR ANGLE = 0
- (11) FRACTIONAL HORSEPOWER LOSS DUE TO INTERSTAGE BLEED = 0
- (12) DESIRED ADIABATIC EFFICIENCY η AT DESIGN POINT ON MAP = 0.88
- (13) DESIRED PRESSURE RATIO PR AT DESIGN POINT ON MAP = 4.1
- (14) DESIGN POINT CORRECTED SPEED $N/\sqrt{\theta}$ = 1.0
- (15) NOT USED

Figure 4. - Defining component characteristics (for a compressor).

KONFIG (1, 30) = 'CNTL'

SPCNTL (1, 30) = 1, 4, 'STAP', 8, 10, 0, 0.001, 1, 2, 2,

VARY SPEC ()
OF COMPONENT ()
SO THAT STATION PROPERTY
NUMBER ()
AT FLOW STATION ()
HAS A TOLERANCE OF ()
AND A VALUE OF ()
THE MINIMUM ALLOWABLE
VALUE OF THE VARIABLE IS ()
AND MAXIMUM VALUE IS ()

Figure 5. - Defining controls.

KONFIG (1, 37) = 'OPTV', 0, 0, 12, 0,
 SPEC (1, 37) = 0, 248, 826, 1, 4*0., 0.1,

THE COMPONENT NUMBER WHICH HAS THE FREE VARIABLE

MIN. ALLOWABLE VALUE NOT USED
 MAX. ALLOWABLE VALUE NOT USED
 WHICH SPEC IS FREE VAR 4 SLOTS NOT USED
 ABSOLUTE TOLERANCE TO WHICH THIS VARIABLE IS TO BE OPTIMIZED

Figure 6. - Defining optimization variables.

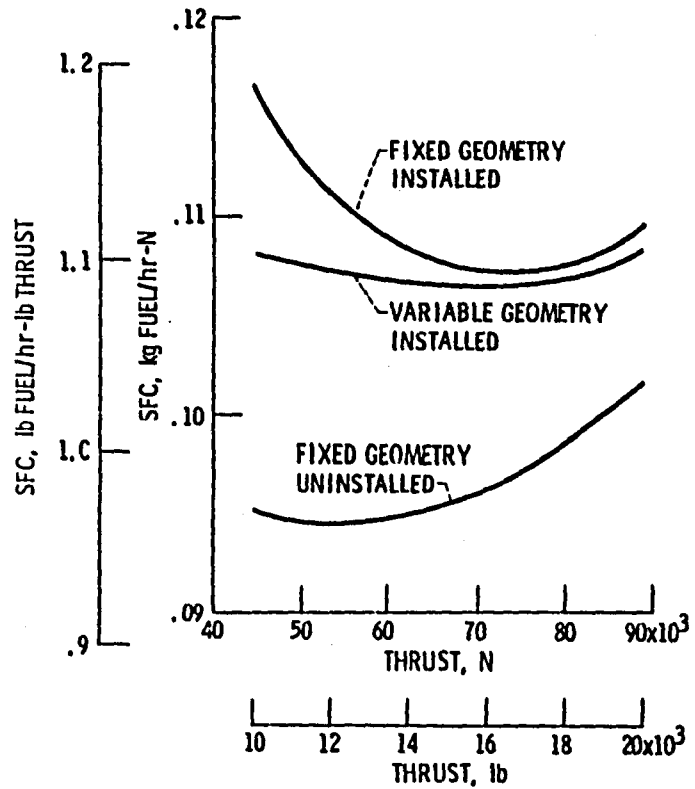

Figure 7. - Engine specific fuel consumption as a function of engine thrust.

ENGINE	MANUFACTURER	MANUFACTURING STATUS ¹	TYPE OF CYCLE ²	AUGMENTATION ³	PRIMARY USE ⁴
GE4J4C	GE	P	TJ	AB	C
GE4J5	GE	X	TJ	AB	C
GE9/F2B	GE	X	TF	AB	M
JT11F	P&WA	P	TJ	AB	M
TJ70	WE	S	TJ	AB	C
GE4J6G	GE	S	TJ	AB	C
GE4J5H2	GE	S	TJ	--	C
JT8D-15	P&WA	P	TF	--	C
JT9D	P&WA	P	TF	--	C
TF34	GE	P	TF	--	M
VSCE-502	P&WA	S	TF	DH	C
VCE-201A	P&WA	S	VCE	--	C
VCE-201B	P&WA	S	VCE	--	C
VCE302A	P&WA	S	VCE	--	C
VSCE-502B	P&WA	S	TF	DH	C
VCE-1123	P&WA	S	VCE	--	C
VSCE-501	P&WA	S	TF	DH	C
VCE-110B	P&WA	S	VCE	--	C
A/B TF-2	P&WA	S	TF	AB	C
D/H TF-2	P&WA	S	TF	DH	C
D/H TF-12	P&WA	S	TF	DH	C
JT10D	P&WA	X	TF	--	C
CFM56	GE/SNECMA	P	TF	--	C
CF6-50	GE	P	TF	--	C
CF6	GE	P	TF	--	C
JT8D	P&WA	P	TF	--	C
CJ805-23	GE	P	TF	--	C
YJ93	GE	P	TJ	AB	M
JT3D	P&WA	P	TF	--	C

¹MANUFACTURING STATUS P - PRODUCTION, S - STUDY PROPOSAL, X - EXPERIMENTAL

²TJ - TURBOJET, TF - TURBOFAN, VCE - VARIABLE CYCLE ENGINE

³AUGMENTATION TYPE AB - AFTERBURNER, DH - DUCTHEATER

⁴C - COMMERCIAL, M - MILITARY

Figure 8. - Data base engines.

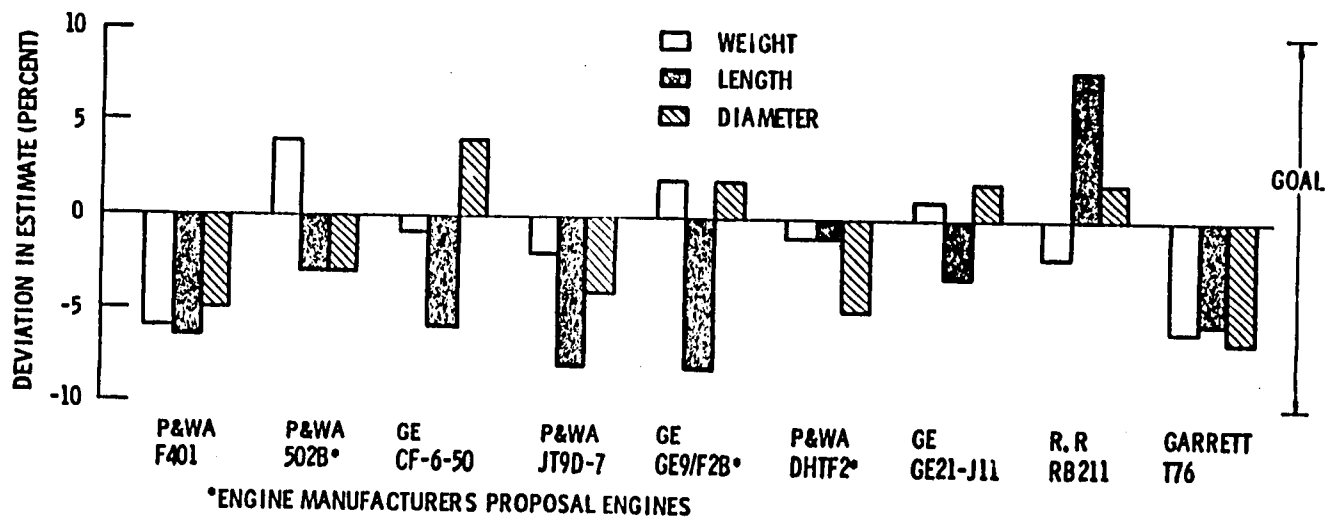

Figure 9. - Program results compared to manufacturers quotations.

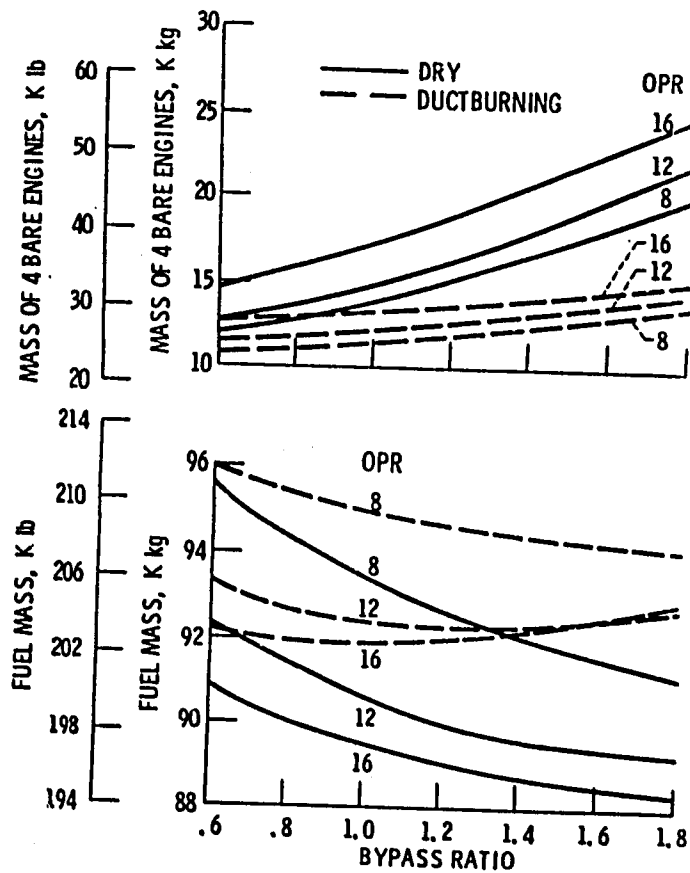

Figure 10. - Fuel mass and bare engine mass, 88 950 N (20 000 lb) thrust engines.

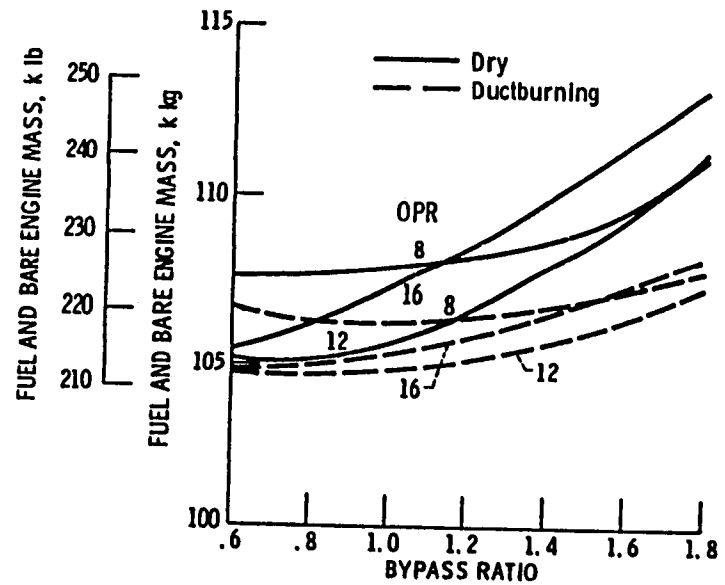

Figure 11. - Sum of engine plus fuel mass, 88 950 N (20 000 lb) thrust engines.

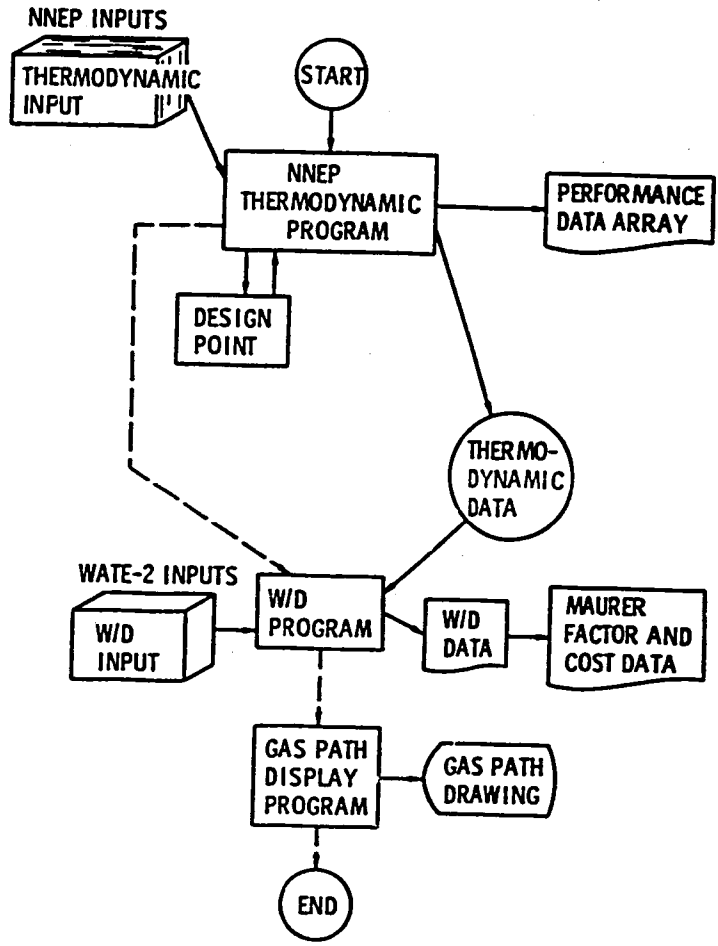

Figure 12. - Overall program structure.

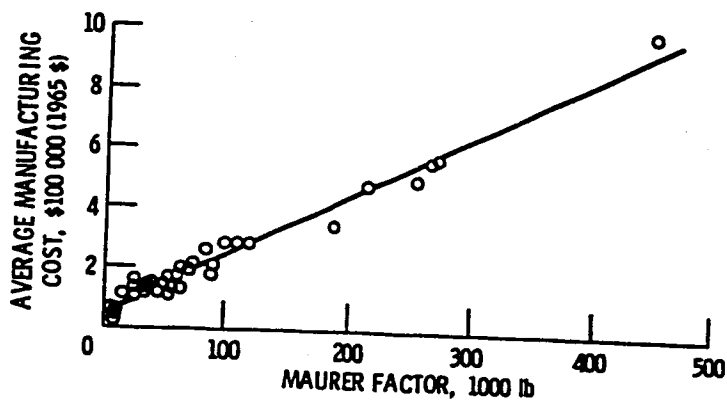
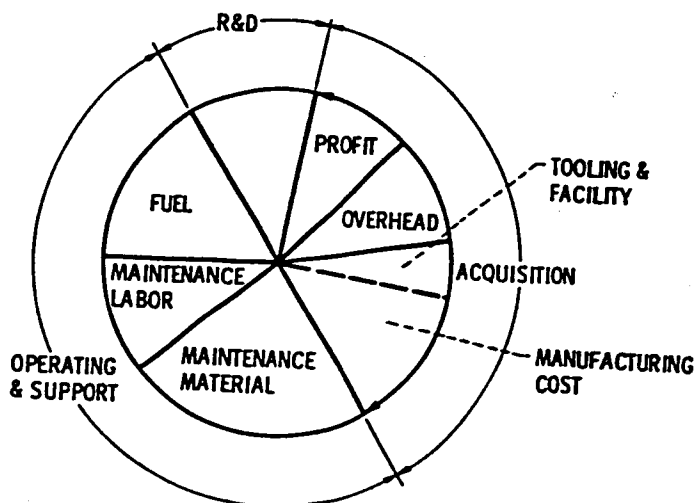

Figure 13. - maurer factor correlation with cost.



MANUFACTURING COST = (WT PROGRAM PREDICTION + MATERIAL SELECTOR) x (RAW TO FINISHED WT) RAW MATERIAL WT AND TYPE

Figure 14. - Engine life cycle cost.

F-112

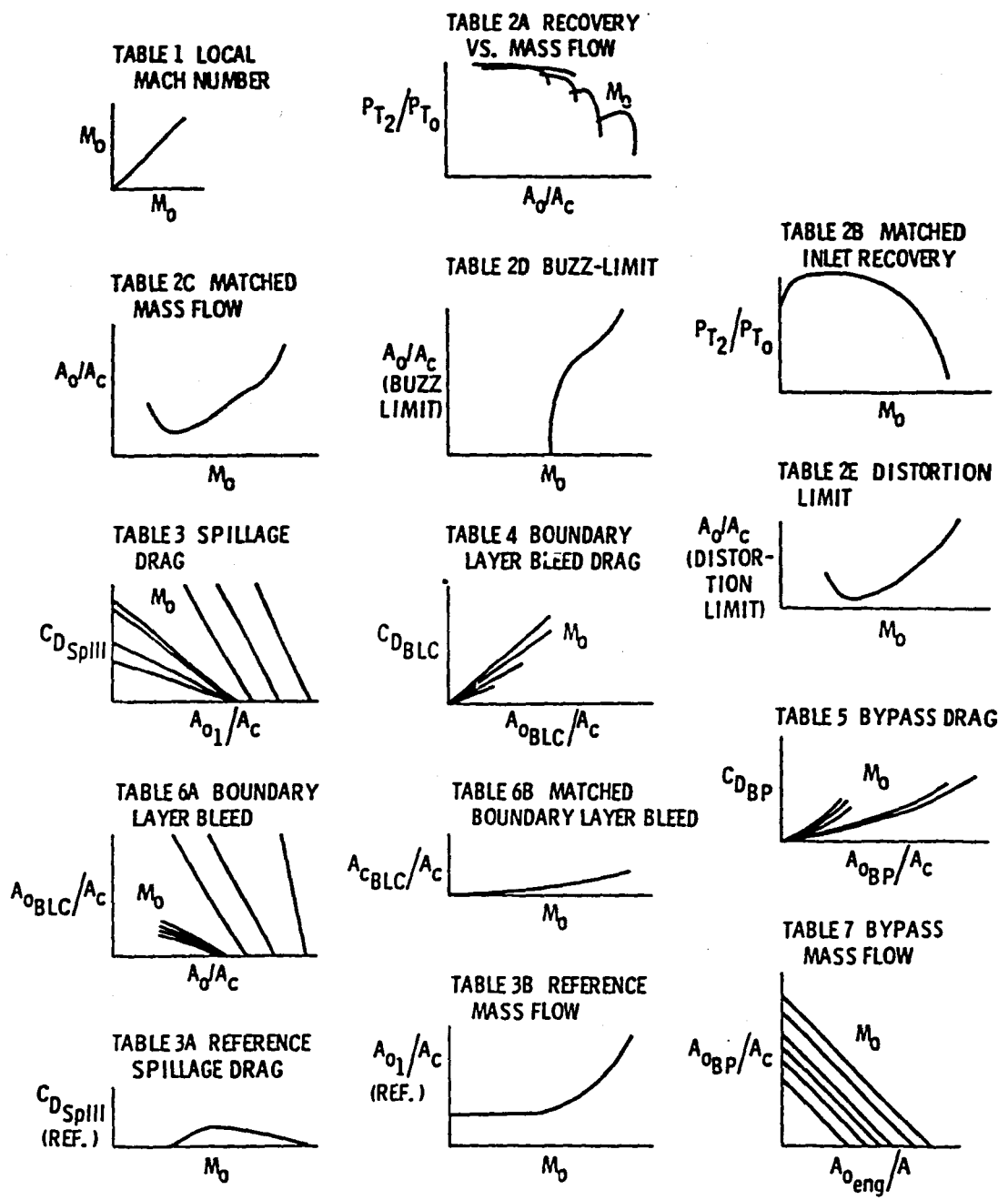
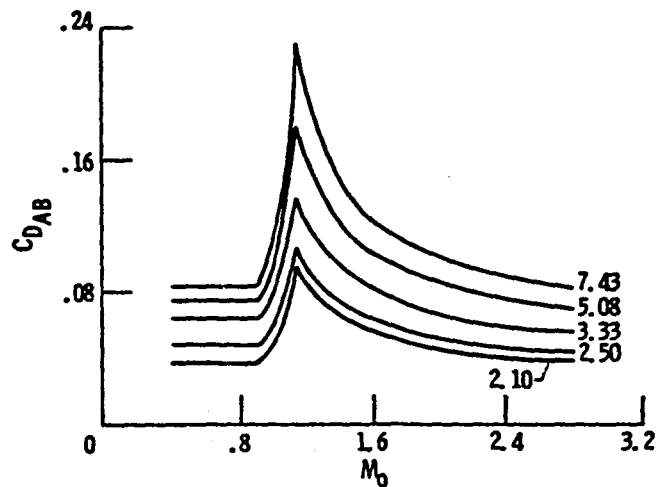
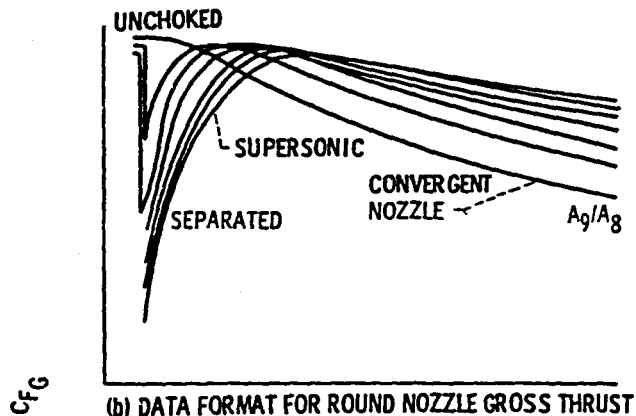

Figure 15. - Format for inlet performance characteristics maps.



(a) DATA FORMAT FOR NOZZLE/AFTBODY DRAG.



(b) DATA FORMAT FOR ROUND NOZZLE GROSS THRUST COEFFICIENT.

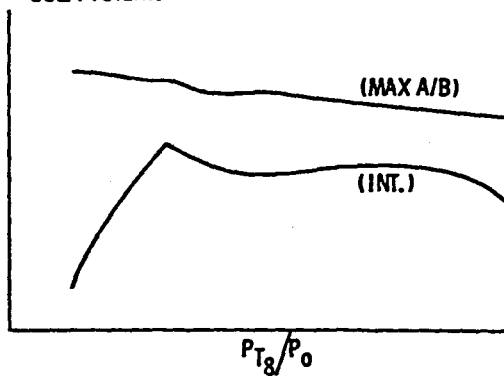

(c) DATA FORMAT FOR NOZZLE GROSS THRUST COEFFICIENT FOR TWO-DIMENSIONAL NOZZLES.

Figure 16. - Format for nozzle/afterbody drag and C_{FG} maps.

E-112

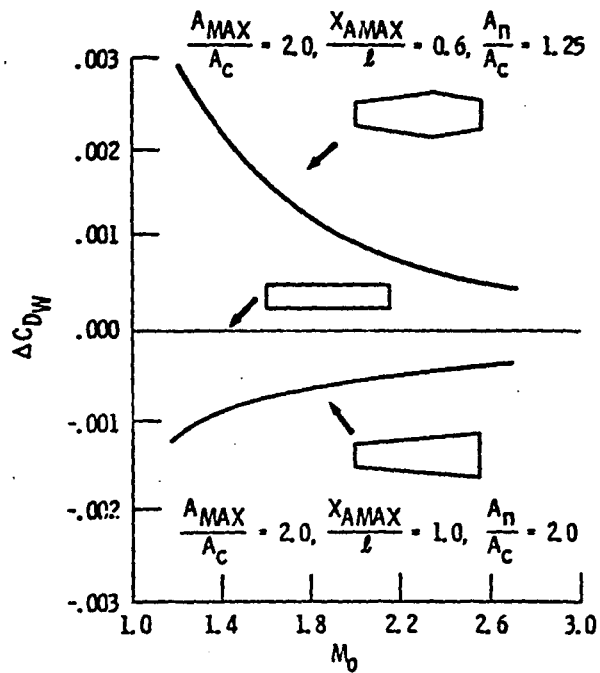

Figure 17. - Typical nacelle incremental wave drag variations with Mach number $A_c = 2.79$ sq m (30 sq ft), $l/d_c = 5.5$.

**END
DATE
FILMED**

OCT 1 1979

End of Document