

NASA Contractor Report 159103



NASA-CR-159103

197900 22183

Data Development for ASTM E24.06.02 Round Robin Program on Instability Prediction

D.E. McCabe

**Westinghouse R&D Center
1310 Beulah Road
Pittsburgh, PA 15235**

**CONTRACT NAS1-15461
August 1979**

LIBRARY COPY

SEP 10 1979

LANGLEY RESEARCH CENTER
LIBRARY, NASA
HAMPTON, VIRGINIA

NASA

National Aeronautics and
Space Administration

Langley Research Center
Hampton, Virginia 23665
AC 804 827-3966

NASA Contractor Report 159103

**Data Development for ASTM E24.06.02
Round Robin Program on Instability
Prediction**

D.E. McCabe

**Westinghouse R&D Center
1310 Beulah Road
Pittsburgh, PA 15235**

**CONTRACT NAS1-15461
August 1979**

NASA

National Aeronautics and
Space Administration

Langley Research Center
Hampton, Virginia 23665
AC 804 827-3966

N79-30354[#]

DATA DEVELOPMENT FOR ASTM E24.06.02 ROUND ROBIN
PROGRAM ON INSTABILITY PREDICTION

D. E. McCabe
Structural Behavior of Materials Department

ABSTRACT

The principal objective of this project was to develop basis data for use in an ASTM E24.06.02 task group round robin activity. Compact specimens were made of 2024-T351, 7075-T651 aluminum alloys, and 304 stainless steel. All were 12.7 mm thick and planar dimension variables incorporated were for 1T, 2T and 4T sizes. Representative raw data for each material and specimen size are contained herein. R-curves plotted in terms of Δa physical and Δa effective are plotted for each material.

BACKGROUND

This report represents a presentation of data generated on three materials representing brittle, intermediate, and ductile toughness behavior. The compact specimen geometry was used with three planar dimension sizes of 1T, 2T, and 4T, but with thickness nominally constant at 12.7 mm. Displacement was measured at three locations along the crack plane at V_o , V_{LL} , and V_2 locations indicated in Figure 1. Two x-y recorders were used. One was a two pen type that plotted V_o and V_{LL} displacement against applied load. A second recorder plotted V_o displacement versus V_2 displacement, (Double Compliance). All specimens were periodically partially unloaded to obtain unloading slopes which are used to measure slow-stable crack advance, Δa physical. In addition, the crack growth was followed to the nearest 1.3 mm by observation on the specimen surfaces. Such optical measurements are highly imprecise, especially with plastic zone interference and crack tunneling tendencies.

TYPICAL DATA SETS

In all, 27 specimens were tested and Tables I through IX represent the typical basic data for each set of three replicates. The specimen code is as follows:

<u>Code (Material)</u>	<u>Plate #</u>	<u>Code - Size</u>
AC (2024)	2	1 = 4T
BC (7075)	5	2 = 2T
SC (304 SS)	8	3 or 5 = 1T

Example; AC5-2 = 2024 Al, Plate #5, 2T specimen.

The data listed are for each unloading point on the test records and the corresponding effective crack aspect ratios, a_e/W , (with plastic zone correction), and physical crack aspect ratios, a_p/W , (from unloading slopes) are given. The determinations are made for V_o and V_{LL} using single compliance and V_o/V_2 for double compliance. Crack growth resistance, K_R , is calculated using a_e/W . This will be acceptable and will give K_R values equivalent to J except for 304 stainless on data points generated at nominal stress greater than 2 times material yield strength. Supplementary information includes initial crack aspect ratio, a_o/W , specimen thickness, B_o , loading rate, \dot{P} , and elastic moduli indicated from the initial linear elastic part of the load-displacement record.

SUMMARY DATA

Tables X through XII summarize the maximum load data from all specimens. Values of initial dimensions, maximum load, and displacements at first attainment of maximum load are given. Do not look for an exact matchup point for these data with values reported in Tables I through IX, because the latter are at each unloading point which may or may not coincide with maximum load. Two of 27 specimens were lost to the unknowns in equipment setup.

R-CURVES

Figures 2 through 7 are R-curves for the three materials with data points for three specimen sizes superimposed. Physical crack growth is from unloading compliance for the two aluminum alloys. This was justified by a better than 5% correlation to surface measured crack size (visual). The unloading compliance on the stainless steel had equal precision and testing technique applied but the comparison to visual was unacceptable. Therefore the Δa_p plot is made in terms of optical Δa_p values which are considerably less than precise as noted before.

FATIGUE PRECRACKING

The fatigue precracking data are given in Table XIII along with the initial crack size measured at five locations across the crack front.

Donald E. McCabe

Principal Investigator:
D. E. McCabe

TABLE I
AC2-1 4T Size Specimen
2024-T351

Event	Load (KN)	Displ. (mm)			a_e/W			a_p/W			K_R MN/m ^{3/2}
		V_o	V_{LL}	V_2	V_o	V_{LL}	V_o/V_2	V_o	V_{LL}	V_o/V_2	
1	13.184	0.84	0.57	0.20	0.504	0.503	--	0.508	0.507	0.475	22.3
2	21.646	1.41	0.95	0.40	0.509	0.507	0.495	0.510	0.500	0.478	37.2
3	28.283	1.87	1.28	0.55	0.512	0.513	0.505	0.506	0.501	0.485	49.3
4	36.300	2.51	1.71	0.75	0.522	0.522	0.515	0.511	0.510	0.487	65.1
5	42.135	3.05	2.12	0.94	0.533	0.534	0.525	0.513	0.510	0.487	78.5
6	48.326	3.82	2.65	1.23	0.551	0.551	0.545	0.515	0.513	0.503	95.6
7	51.488	4.51	3.18	1.52	0.572	0.572	0.565	0.524	0.522	0.515	109.7
8	52.023	5.18	3.71	1.85	0.596	0.597	0.595	0.530	0.536	0.535	121.4
9	51.355	5.70	4.11	2.11	0.616	0.617	0.620	0.537	0.543	0.544	129.9
10	48.059	6.38	4.67	2.48	0.647	0.648	0.645	0.557	0.561	0.555	138.8
11	42.447	7.03	5.19	2.87	0.681	0.681	0.680	0.583	0.582	0.595	143.8
12	38.572	7.58	5.65	3.18	0.706	0.707	0.700	0.604	0.606	0.625	149.3
13	32.826	8.24	6.20	3.60	0.737	0.737	--	0.607	0.638	0.670	151.4
14	28.550	8.78	6.70	3.94	0.761	0.761	--	0.658	0.662	0.680	153.4

$a_o/W = 0.504$

$B_o = 12.802 \text{ mm}$

$P = 4.855 \text{ KN/min.}$

$V_o = -0.25 \text{ W}$

$V_{LL} = 0$

$V_2 = 0.328 \text{ W}$

Elastic Modulus

@ $V_o = 70.650 \text{ MN/m}^2$

@ $V_{LL} = 69,305 \text{ MN/m}^2$

TABLE II
AC2-2 2T Size Specimen
2024-T351

Event	Load (KN)	Displ. (mm)			a_e/W			a_p/W			K_R MN/m ^{3/2}
		V_o	V_{LL}	V_2	V_o	V_{LL}	V_o/V_2	V_o	V_{LL}	V_o/V_2	
1	8.231	0.56	0.39	0.18	0.510	0.516	0.498	0.516	0.513	0.491	21.0
2	15.923	1.14	0.76	0.36	0.520	0.518	0.498	0.508	0.499	0.492	41.0
3	23.223	1.85	1.23	0.62	0.543	0.541	0.530	0.504	0.499	0.498	64.5
4	27.339	2.53	1.75	0.91	0.573	0.574	0.565	0.513	0.508	0.515	84.7
5	28.759	3.18	2.24	1.22	0.607	0.609	0.600	0.522	0.523	0.535	101.6
6	25.918	3.99	2.90	1.68	0.667	0.666	0.660	0.544	0.554	0.589	117.2
7	21.802	4.64	3.45	2.08	0.710	0.713	0.710	0.576	0.583	0.646	125.4
8	18.373	5.11	3.87	2.39	0.744	0.747	0.745	0.608	0.618	0.666	129.5
9	14.698	5.72	4.36	2.75	0.781	0.783	0.775	0.647	0.656	0.760	132.1

5

$a_o/W = 0.512$
 $B_o = 12.522$ mm
 $P = 12.471$ (KN)/min.
 $V_o = -0.25$ W
 $V_{LL} = 0$
 $V_2 = 0.303$ W

Elastic Modulus

@ $V_o = 66,665$ MN/m²
 @ $V_{LL} = 68.512$ MN/m²

TABLE III
AC8-3 1T Size Specimen
2024-T351

Event	Load (KN)	Displ. (mm)			a_e/W			a_p/W			K_R MN/m ^{3/2}
		V_o	V_{LL}	V_2	V_o	V_{LL}	V_o/V_2	V_o	V_{LL}	V_o/V_2	
1	6.218	0.42	0.28	0.13	0.513	0.516	0.504	0.525	0.526	0.528	21.9
2	11.442	0.83	0.59	0.28	0.536	0.542	0.523	0.517	0.521	0.505	43.7
3	13.981	1.24	0.87	0.44	0.577	0.576	0.555	0.525	0.528	0.520	60.8
4	14.774	1.63	1.17	0.64	0.618	0.618	0.615	0.535	0.539	0.530	75.5
5	13.807	2.21	1.52	0.88	0.679	0.669	0.620	0.556	0.562	0.554	90.8
6	12.587	2.47	1.83	1.09	0.708	0.707	0.695	0.569	0.577	0.600	98.9
7	10.623	2.92	2.20	1.34	0.750	0.749	0.735	0.607	0.613	0.659	106.4
8	8.258	3.34	2.53	1.61	0.791	0.790	0.765	0.648	0.648	0.715	110.0
9	6.218	3.86	2.97	1.91	0.828	0.828	0.807	0.690	0.693	0.730	113.3

$a_o/W = 0.522$

$B_o = 12.548 \text{ mm}$

$\dot{p} = 32.07 \text{ KN/min.}$

$V_o = -0.25 \text{ W}$

$V_{LL} = 0$

$V_2 = 0.303 \text{ W}$

Elastic Modulus

@ $V_o = 71,008 \text{ MN/m}^2$

@ $V_{LL} = 70,843 \text{ MN/m}^2$

TABLE IV
BC5-1 4T Size Specimen
7075-T651

Event	Load (KN)	Displ. (mm)			a_e/W			a_p/W			K_R MN/m ^{3/2}
		V_o	V_{LL}	V_2	V_o	V_{LL}	V_o/V_2	V_o	V_{LL}	V_o/V_2	
1	16.569	1.04	0.74	0.30	0.505	0.504	0.500	0.509	0.504	0.480	27.7
2	21.179	1.45	1.01	0.43	0.524	0.516	0.510	0.523	0.512	0.502	37.3
3	22.916	1.65	1.17	0.51	0.535	0.529	0.522	0.530	0.514	0.505	41.9
4	24.052	1.91	1.32	0.61	0.554	0.543	0.545	0.547	0.531	0.520	46.5
5	23.317	1.99	1.42	0.67	0.570	0.562	0.565	0.558	0.553	0.550	48.0
6	23.450	2.19	1.56	0.76	0.587	0.579	0.580	0.577	0.562	0.560	51.3
7	22.181	2.32	1.68	0.84	0.608	0.601	0.605	0.617	0.583	0.580	52.7
8	20.243	2.48	1.82	0.94	0.636	0.629	0.632	0.622	0.610	0.600	54.0
9	16.636	2.74	2.04	1.10	0.683	0.676	0.670	0.664	0.655	0.655	55.1
10	14.832	2.88	2.17	1.21	0.706	0.700	0.700	0.686	0.676	0.680	55.6
11	12.427	3.07	2.36	1.36	0.737	0.733	--	0.716	0.708	0.705	55.8
12	9.487	3.25	2.55	1.49	0.774	0.771	--	0.756	0.752	--	54.6

$a_o/W = 0.503$

$B_o = 12.675 \text{ mm}$

$\dot{P} = 4.855 \text{ KN/min.}$

$V_o = -0.25 W$

$V_{LL} = 0$

$V_2 = 0.328W$

Elastic Modulus

@ $V_o = 70,215 \text{ MN/m}^2$

@ $V_{LL} = 66,320 \text{ MN/m}^2$

TABLE V
BC8-2 2T Size Specimen
7075-T651

Event	Load (KN)	Displ. (mm)			a_e/W			a_p/W			K_R MN/m ^{3/2}
		V_o	V_{LL}	V_2	V_o	V_{LL}	V_o/V_2	V_o	V_{LL}	V_o/V_2	
1	8.387	0.57	0.37	0.18	0.513	0.514	0.495	0.511	0.504	0.488	20.4
2	12.881	0.90	0.57	0.30	0.520	0.516	0.534	0.521	0.521	0.511	31.8
3	14.181	1.17	0.79	0.43	0.555	0.560	0.565	0.543	0.541	0.530	39.9
4	12.734	1.53	1.07	0.63	0.627	0.630	0.640	0.601	0.604	0.612	47.1
5	11.032	1.70	1.23	0.75	0.668	0.672	0.699	0.645	0.644	0.643	49.3
6	8.788	1.85	1.37	0.88	0.713	0.718	0.760	0.689	0.692	0.707	49.7
7	6.191	2.32	1.57	1.06	0.768	0.772	--	0.748	0.748	0.766	49.3
8	4.044	2.41	1.87	1.29	0.822	0.820	--	0.803	0.804	--	49.3

$a_o/W = 0.509$

$B_o = 12.802 \text{ mm}$

$P = 12.471 \text{ KN/min.}$

$V_o = -0.25 \text{ W}$

$V_{LL} = 0$

$V_2 = 0.303 \text{ W}$

Elastic Modulus

@ $V_o = 67,127 \text{ MN/m}^2$

@ $V_{LL} = 70,332 \text{ MN/m}^2$

TABLE VI
BC8-3 1T Specimen Size
7075-T651

Event	Load (KN)	Displ. (mm)			a_e/W			a_p/W			K_R MN/m ^{3/2}
		V_o	V_{LL}	V_2	V_o	V_{LL}	V_o/V_2	V_o	V_{LL}	V_o/V_2	
1	8.231	0.53	0.35	0.18	0.513	0.505	0.530	0.508	0.509	0.489	28.0
2	8.231	0.64	0.44	0.23	0.554	0.547	0.570	0.539	0.548	0.541	32.1
3	8.182	0.78	0.56	0.31	0.595	0.594	0.630	0.571	0.572	0.575	37.5
4	8.155	0.90	0.65	0.36	0.622	0.618	0.627	0.594	0.586	0.595	41.4
5	6.984	1.06	0.76	0.48	0.673	0.668	0.715	0.636	0.636	0.670	44.3
6	5.336	1.15	0.88	0.55	0.723	0.723	0.770	0.685	0.689	0.701	44.8
7	4.142	1.30	0.99	0.61	0.767	0.764	0.747	0.728	0.733	0.750	45.3
8	2.993	1.38	1.07	0.69	0.805	0.804	0.811	0.766	0.769	0.810	43.8
9	2.370	1.51	1.17	0.76	0.832	0.830	0.830	0.795	0.797	0.815	43.7

$a_o/W = 0.508$

$B_o = 12.751 \text{ mm}$

$\dot{P} = 34.741 \text{ KN/min.}$

$V_o = -0.25 \text{ W}$

$V_{LL} = 0$

$V_2 = 0.303 \text{ W}$

Elastic Modulus

@ $V_o = 71,208 \text{ MN/m}^2$

@ $V_{LL} = 69,643 \text{ MN/m}^2$

TABLE VII
SC2-1 4T Size Specimen
304 Stainless Steel

Event	Load (KN)	Displ. (mm)			a_e/W			a_p/W		K_R MN/m ^{3/2}
		V_o	V_{LL}	V_2	V_o	V_{LL}	V_o/V_2	V_o	V_{LL}	
0	13.362	0.30	0.20	0.08	0.505	0.501	0.492	--	--	22.2
1	33.672	0.85	0.56	0.25	0.532	0.524	0.510	0.506	0.502	60.8
2	50.330	1.56	1.07	0.49	0.574	0.570	0.522	0.507	0.506	105.7
3	60.485	2.40	1.65	0.80	0.620	0.613	0.560	0.507	0.501	150.8
4	66.097	3.23	2.26	1.12	0.655	0.649	0.585	0.505	0.506	192.2
5	71.086	4.39	3.12	1.60	0.691	0.686	0.608	0.505	0.499	246.6
6	73.936	5.28	3.79	1.97	0.711	0.707	0.620	0.504	0.502	286.0
7	78.301	6.95	5.02	2.63	0.739	0.735	0.630	0.501	0.499	356.2
8	80.795	8.29	6.04	3.19	0.756	0.752	0.640	0.495	0.498	409.0
9	83.201	9.91	7.24	3.87	0.772	0.768		0.495	0.494	468.9
10	85.071	11.30	8.27	4.45	0.784	0.779		0.495	0.494	520.4
11	86.318	12.78	9.38	5.05	0.794	0.790		0.498	0.498	571.2
12	86.853	14.33	10.55	5.73	0.804	0.800		0.500	0.502	621.6
13	86.853	15.60	11.51	6.28	0.811	0.808		0.502	0.507	660.9
14	86.497	17.35	12.87	7.21	0.821	0.818		0.509	0.516	718.0
15	85.873	18.86	13.97	7.72	0.828	0.825		0.515	0.523	757.7
16	84.982	20.22	15.04	7.98	0.834	0.832		0.521	0.525	796.4
17	84.181	21.34	15.91	8.49	0.839	0.837		0.525	0.531	827.6

$a_o/W = 0.502$

$B_o = 12.776$ mm

$\dot{P} = 10.436$ KN/min.

$V_o = -0.25$ W

$V_{LL} = 0$

$V_2 = 0.328$ W

Elastic Modulus

@ $V_o = 196,369$ MN/m²

@ $V_{LL} = 196,748$ MN/m²

TABLE VIII
SC8-2 2T Size Specimen
304 Stainless Steel

Event	Load (KN)	Displ. (mm)			a_e/W			a_p/W			K_R MN/m ^{3/2}
		V_o	V_{LL}	V_2	V_o	V_{LL}	V_o/V_2	V_o	V_{LL}	V_o/V_2	
1	19.842	0.57	0.36	0.18	0.560	0.547	0.500	0.498	0.494	0.472	54.1
2	33.316	1.71	1.13	0.62	0.664	0.655	0.562	0.498	0.494	0.485	139.0
3	37.480	2.88	1.96	1.10	0.721	0.715	0.596	0.502	0.494	0.472	211.4
4	41.400	4.53	3.15	1.18	0.763	0.759	0.625	0.506	0.494	0.515	304.3
5	43.115	5.61	3.95	2.28	0.782	0.778	0.630	0.490	0.494	0.501	361.8
6	45.074	7.12	5.04	2.92	0.800	0.797	0.640	0.494	0.494	0.513	435.0
7	46.299	8.37	5.98	3.46	0.812	0.810	0.647	0.490	0.504	0.505	494.7
8	47.181	9.31	6.68	3.88	0.820	0.817	0.658	0.486	0.499	0.555	537.6
9	47.769	10.64	7.68	4.50	0.830	0.828	0.665	0.498	0.499	0.525	598.0
10	47.622	11.86	8.55	5.04	0.838	0.836	0.665	0.510	0.529	0.540	642.9
11	47.475	13.09	9.42	5.60	0.845	0.843	0.670	0.510	0.519	0.540	686.8
12	46.789	14.77	10.69	6.41	0.854	0.853	0.685	0.521	0.524	0.570	747.1
13	46.691	15.57	11.30	6.79	0.858	0.857	0.685	0.521	0.541	0.550	778.6
14	44.878	17.28	12.57	7.45	0.868	0.866	0.675	0.524	0.550	0.512	833.6
15	43.850	18.31	13.39	8.09	0.872	0.871	0.700	0.524	0.550	0.532	859.3

$a_o/W = 0.510$
 $B_o = 13.030$ mm
 $P = 13.362$ KN/min.
 $V_o = -0.25$ W
 $V_{LL} = 0$
 $V_2 = 0.303$ W

Elastic Modulus
 @ $V_o = 193,438$ MN/m²
 @ $V_{LL} = 201,956$ MN/m²

11

TABLE IX
SC8-5 1T Size Specimen
304 Stainless Steel

Event	Load (KN)	Displ. (mm)			a_e/W			a_p/W			K_R MN/m ^{3/2}
		V_o	V_{LL}	V_2	V_o	V_{LL}	V_o/V_2	V_o	V_1	V_o/V_2	
1	9.808	0.25	0.18	0.09	0.541	0.543		0.522	0.505		37.0
2	16.587	0.77	0.55	0.29	0.653	0.645		0.515	0.519		94.9
3	18.872	1.37	0.98	0.53	0.719	0.709		0.511	0.528		149.8
4	20.364	2.01	1.48	0.80	0.756	0.750		0.515	0.528		203.8
5	21.727	2.64	1.94	1.07	0.778	0.772		0.507	0.519		253.1
6	22.720	3.15	2.35	1.30	0.791	0.786		0.491	0.505		292.2
7	23.664	3.91	2.93	1.63	0.808	0.803		0.491	0.509		347.7
8	24.457	4.63	3.49	1.95	0.819	0.815		0.495	0.514		395.9
9	25.450	5.57	4.24	2.36	0.831	0.827		0.499	0.519		458.6
10	25.949	6.29	4.80	2.68	0.839	0.835		0.511	0.509		504.4
11	26.270	6.99	5.35	2.99	0.846	0.842		0.507	0.519		547.0
12	26.693	7.69	5.92	3.31	0.851	0.848		0.507	0.519		588.2
13	26.769	8.31	6.42	3.60	0.856	0.854		0.507	0.519		625.2
14	26.470	9.81	7.27	4.10	0.865	0.862		0.511	0.528		679.6
15	26.145	10.12	7.91	4.47	0.870	0.869		0.522	0.536		720.0
16	25.650	10.69	8.38	4.74	0.8745	0.873		0.522	0.540		743.8

$a_o/W = 0.5175$

$B_o = 12.802$

$P = 13.602 \text{ KN/min}$

$V_o = -0.25 W$

$V_{LL} = 0$

$V_2 = 0.303 W$

Elastic Modulus

@ $V_o = 204,097 \text{ MN/m}^2$

@ $V_{LL} = 198,078 \text{ MN/m}^2$

TABLE X
Summary Data
All 2024-T351

Size	4T	4T	4T	2T	2T	2T	1T	1T	1T
Code	AC2	AC5	AC8	AC2	AC5	AC8	AC2	AC5	AC8
Width (mm)	203	203	203	102	102	102	51	51	51
Thick. (mm)	12.60	--	12.57	12.52	12.60	12.57	12.60	12.55	12.55
A _o (mm)	102.39	--	102.51	51.94	51.61	51.43	26.49	26.31	26.14
P max (KN)	52.11	--	51.89	28.76	28.92	29.76	14.18	14.72	14.77
*V _o max (mm)	4.78	--	5.11	3.18	3.00	2.90	1.67	1.51	1.63
*V _{LL} max (mm)	3.38	--	3.58	2.24	2.08	1.98	1.17	1.06	1.17
*V ₂ max (mm)	1.66	--	1.83	1.22	1.17	1.09	0.65	0.56	0.64
*K _R max (MN/m ^{3/2})	114.4	--	120.0	101.6	105.0	95.1	76.4	72.4	75.5

*Max. stands for at maximum load.

TABLE XI
Summary Data
A11 7075-T651

Size	4T	4T	4T	2T	2T	2T	1T	1T	1T
Code	BC2	BC5	BC8	BC2	BC5	BC8	BC2	BC5	BC8
Width (mm)	203	203	203	102	102	102	51	51	51
Thick. (mm)	12.78	12.67	12.78	12.78	12.70	12.80	--	12.72	12.75
A _o (mm)	102.00	102.24	100.81	50.80	50.72	51.38	--	25.58	25.65
P max (KN)	24.05	24.12	25.43	15.51	15.54	14.53	--	8.73	8.85
*V _o max (mm)	2.10	1.96	1.91	1.24	1.34	1.19	--	0.83	0.70
*V _{LL} max (mm)	1.45	1.36	1.32	0.84	0.90	0.80	--	0.58	0.49
*V ₂ max (mm)	0.69	0.67	0.64	0.46	0.48	0.44	--	0.31	0.26
*K _R max (MN/m ^{3/2})	49.8	48.6	48.1	41.4	45.2	40.4	--	39.0	34.4

* Max. stands for at maximum load.

TABLE XII
Summary Data
304 Stainless Steel

Size	4T	4T	4T	2T	2T	2T	1T	1T	1T
Code	SC2	SC5	SC8	SC2	SC5	SC8	SC2	SC5	SC8
Width (mm)	203	203	203	102	102	102	51	51	51
Thick. (mm)	12.78	12.83	12.80	13.00	13.08	13.03	12.80	12.80	12.80
A _o (mm)	102.03	102.29	102.00	49.35	50.72	51.36	25.65	26.06	25.78
P max (KN)	86.85	85.34	85.29	55.12	50.81	47.77	27.31	25.87	26.77
*V _o max (mm)	14.33	15.32	15.77	10.77	10.31	10.64	7.77	7.65	8.31
*V _{LL} max (mm)	10.57	11.49	11.89	7.62	7.47	7.67	5.97	6.48	6.43
*V ₂ max (mm)	5.74	6.38	6.60	4.34	4.29	4.5	3.28	3.33	3.61
*K _R max (MN/m ^{3/2})	621.5	660	652	621	574	598	581	--	625

*Max. stands for at maximum load.

TABLE XIII
Fatigue Precracking

Code	Machine Notch (mm)	Initial Cycles		Final Cycles		Precrack Size (mm)					
		Load (KN)	Number	Load (KN)	Number	Left	1/4	1/2	3/4	Right	Avg.
AC2-1	99.1	9.8	4,400	6.68	45,900	101	103	102	103	102	102.4
AC5-1	99.1	9.8	5,400	6.68	25,900	102	103	104	103	102	102.8
AC8-1	99.1	9.8	4,300	6.68	35,200	101	103	103	103	102	102.5
BC2-1	99.1	9.8	3,600	6.68	12,000	101	102	103	102	102	102.0
BC5-1	99.1	9.8	3,900	6.68	14,800	102	102	102	102	102	102.2
BC8-1	99.1	9.8	3,100	6.68	17,200	101	101	101	101	100	100.8
SC2-1	99.1	9.8	66,700	6.68	335,300	102	102	102	102	101	102.0
SC5-1	99.1	9.8	115,600	6.68	628,400	102	103	103	103	101	102.3
SC8-1	99.1	9.8	46,300	6.68	408,700	101	102	102	102	101	102.0
AC2-2	48.3	7.13	6,000	4.90	22,000	51	52	53	52	51	52.0
AC5-2	48.3	7.13	1,800	4.90	24,600	50	52	52	52	51	51.6
AC8-2	48.3	7.13	1,800	4.90	17,800	50	52	52	52	51	51.4
BC2-2	48.3	7.13	3,700	4.90	5,600	50	51	51	51	50	50.8
BC5-2	48.3	7.13	2,900	4.90	6,100	50	51	51	51	50	50.7
BC8-2	48.3	7.13	1,900	4.90	11,100	51	52	52	52	50	51.4
SC2-2	48.3	7.13	81,00	4.90	56,000	51	49	48	49	49	49.4
SC5-2	48.3	7.13	374,000	4.90	1,626,000	51	52	51	50	49	50.7
SC8-2	48.3	7.13	167,000	4.90	8,133,000	50	52	52	52	51	51.3
AC2-3	22.9	4.90	3,500	3.34	27,700	25	27	27	27	26	26.5
AC5-3	22.9	4.90	5,400	3.34	6,200	25	27	27	27	26	26.8
AC8-3	22.9	4.90	3,200	3.34	28,200	26	26	27	27	25	26.1
BC2-3	22.9	4.90	1,800	3.34	8,000	---	---	---	---	---	---
BC5-3	22.9	4.90	2,000	3.34	7,300	25	26	26	26	25	25.6
BC8-3	22.9	4.90	1,300	3.34	8,500	25	26	26	26	25	25.6
SC2-5	22.9	4.10	754,000	3.61	2,846,000	25	26	26	26	25	25.6
SC5-5	22.9	4.10	721,000	3.61	2,479,000	25	27	27	26	25	26.1
SC8-5	22.9	4.10	627,000	3.61	1,973,000	25	26	26	26	25	25.8

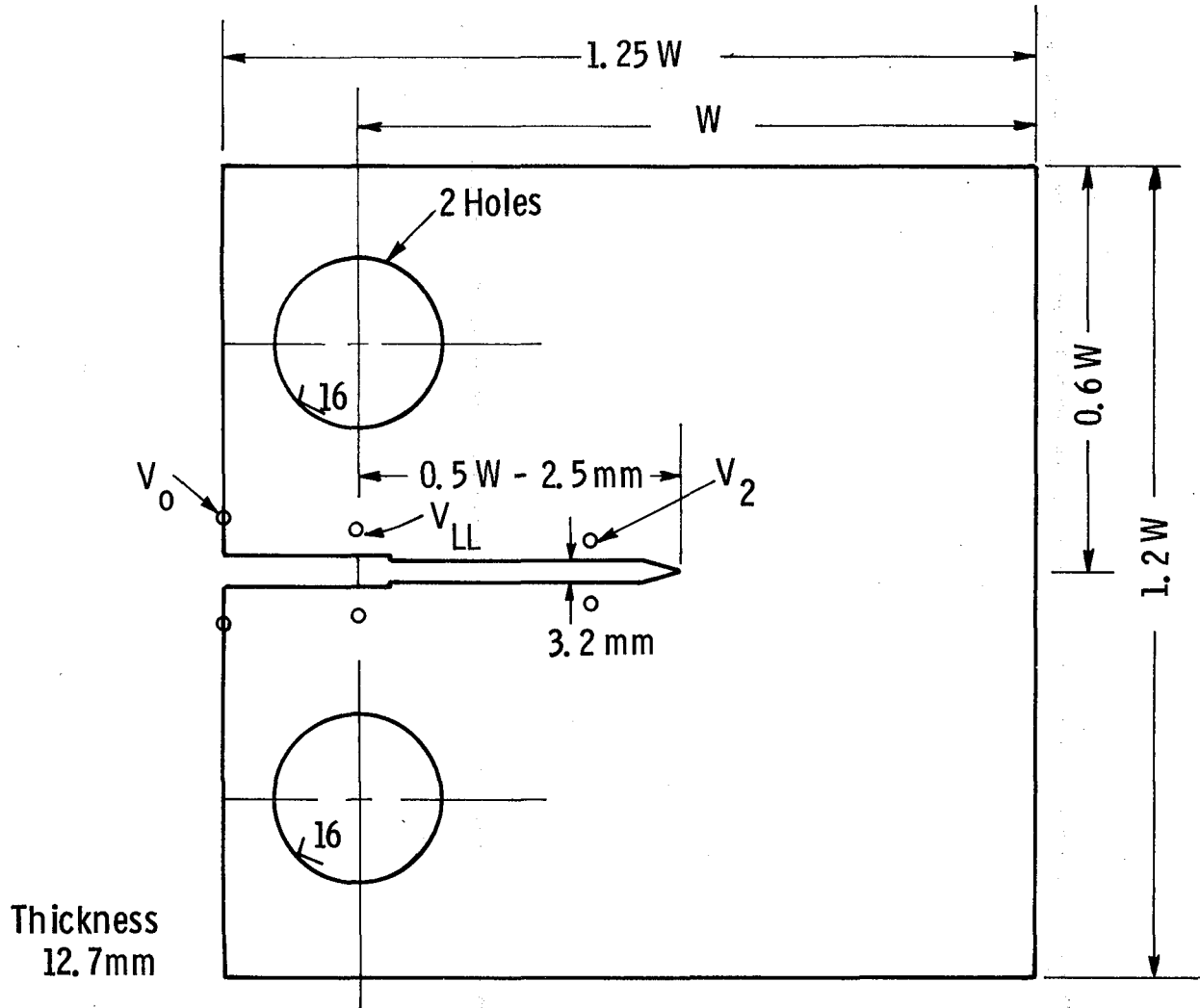

Fig. 1 - Compact specimen geometry

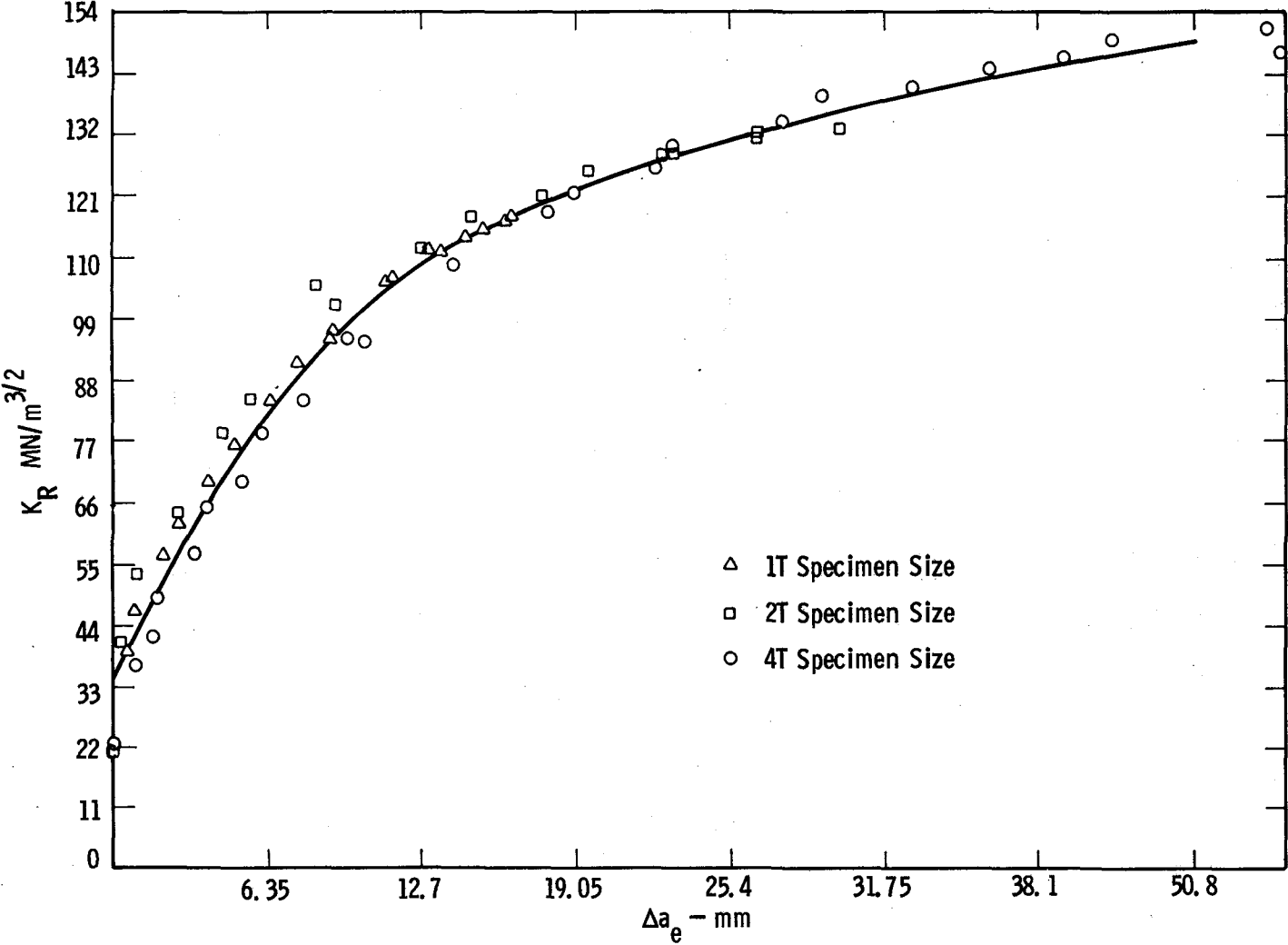

Fig. 2 - 2024-T351

Curve 716287-B

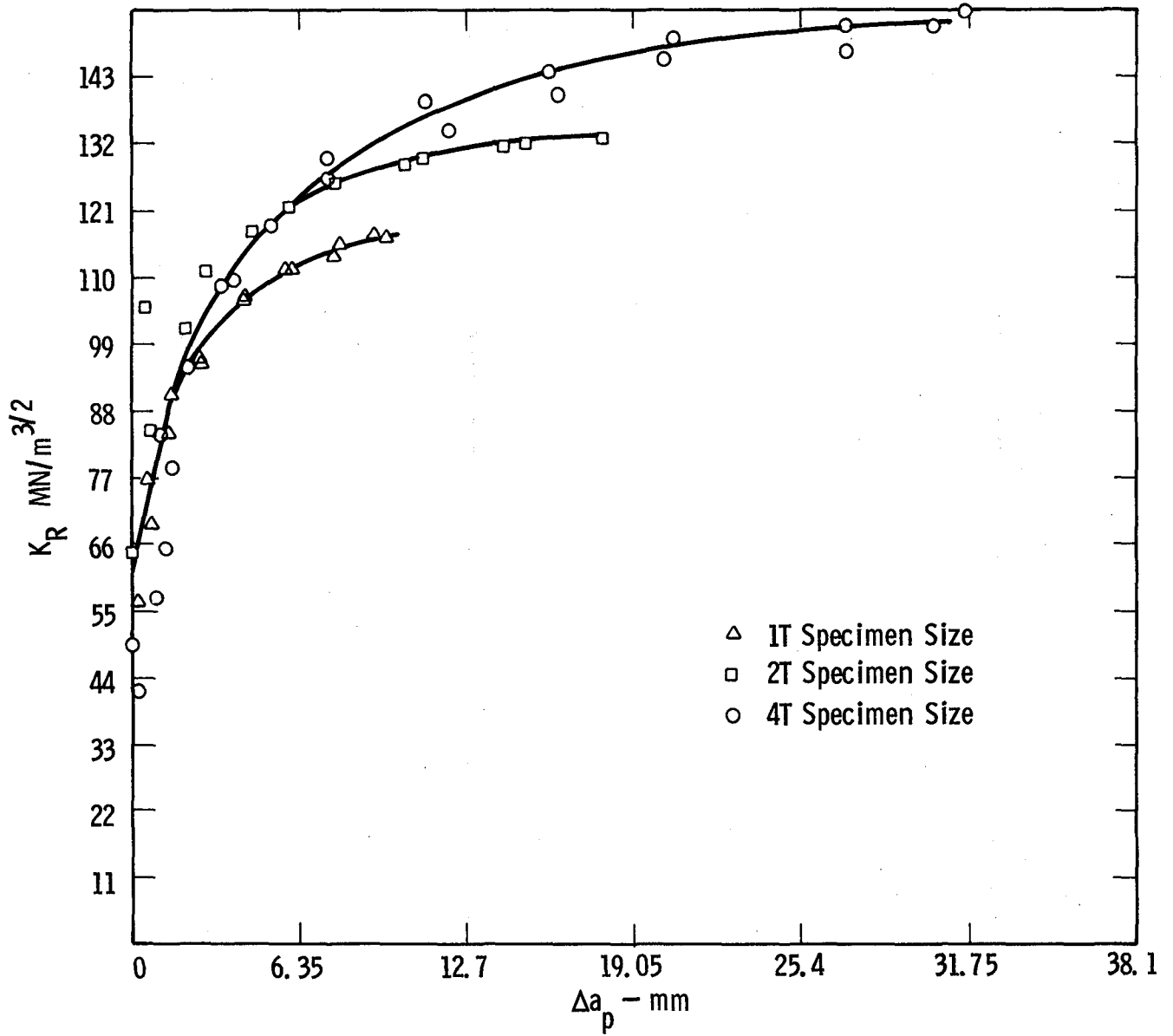

Fig. 3 - 2024-T351

Curve 716288-A

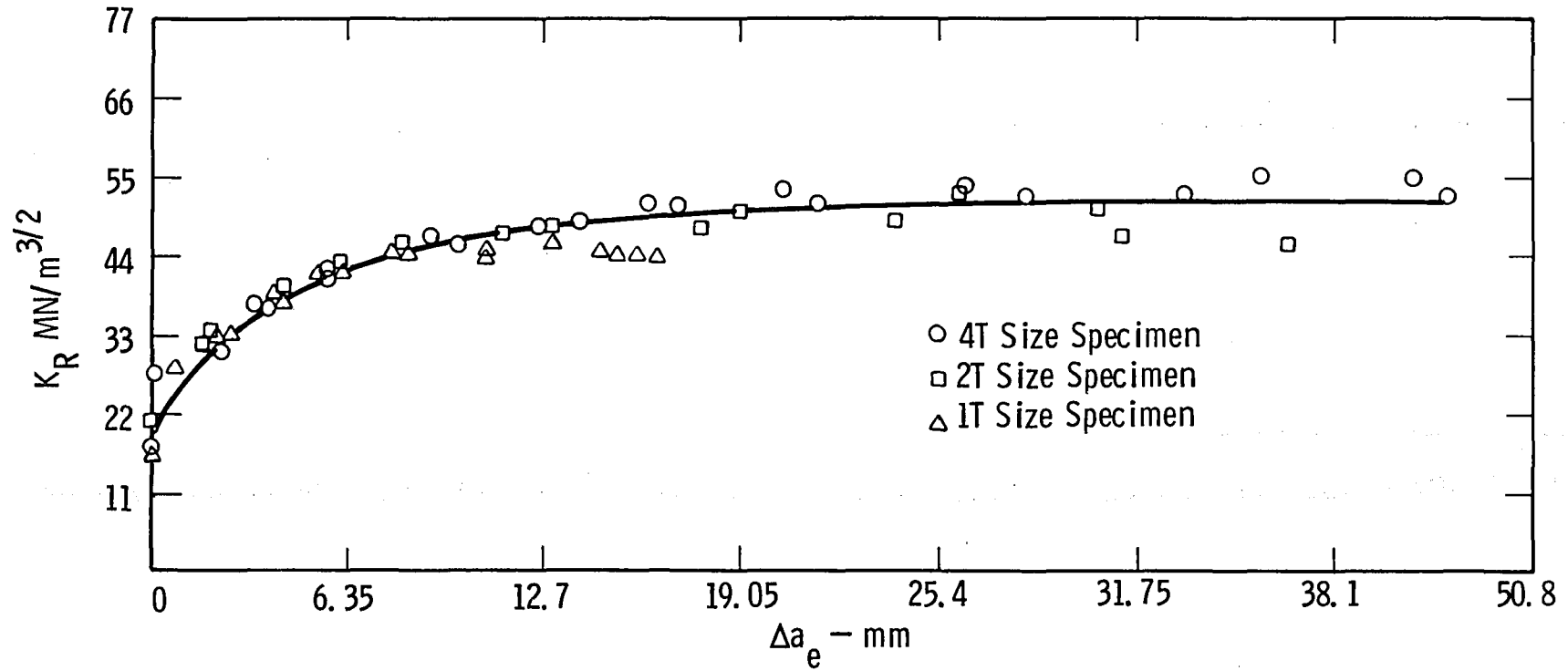

Fig. 4 - 7075 - T651

Curve 716289-A

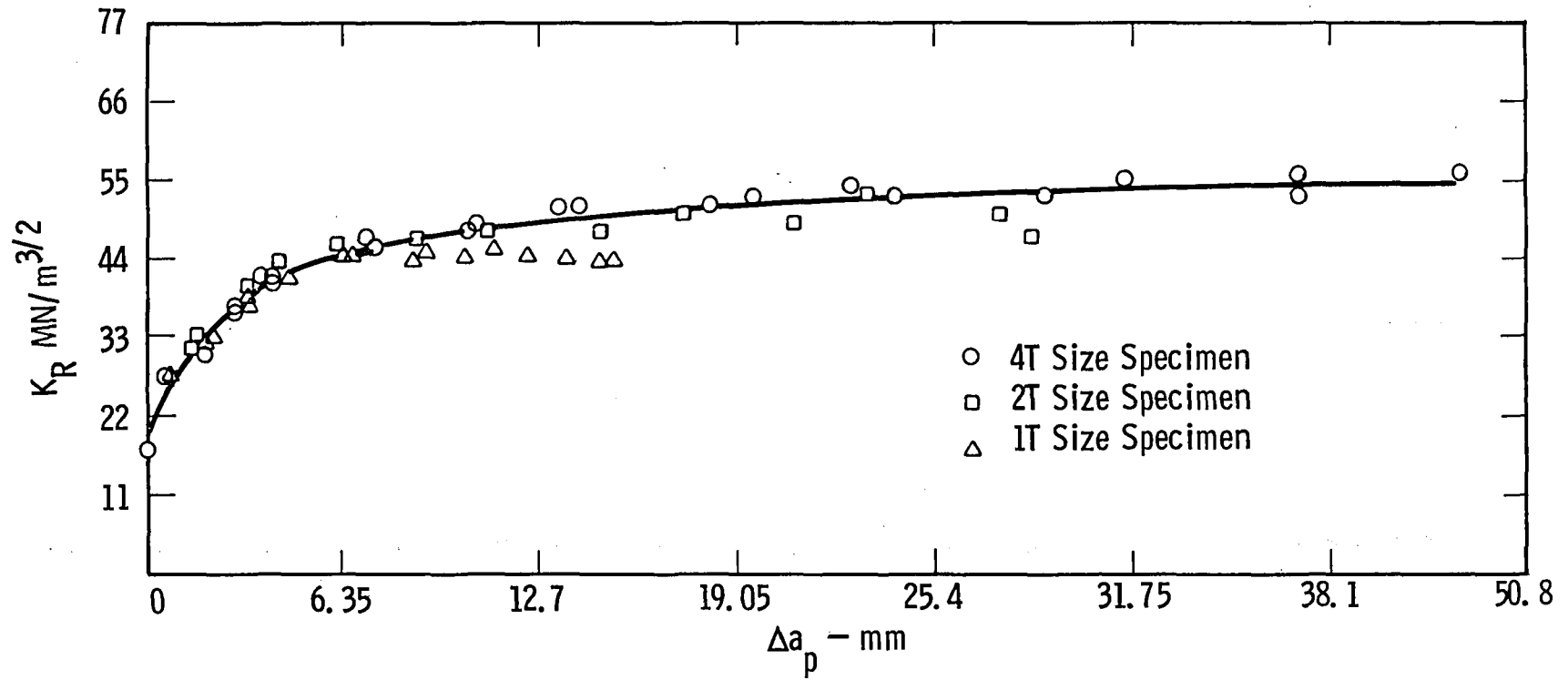

Fig. 5-7075-T651

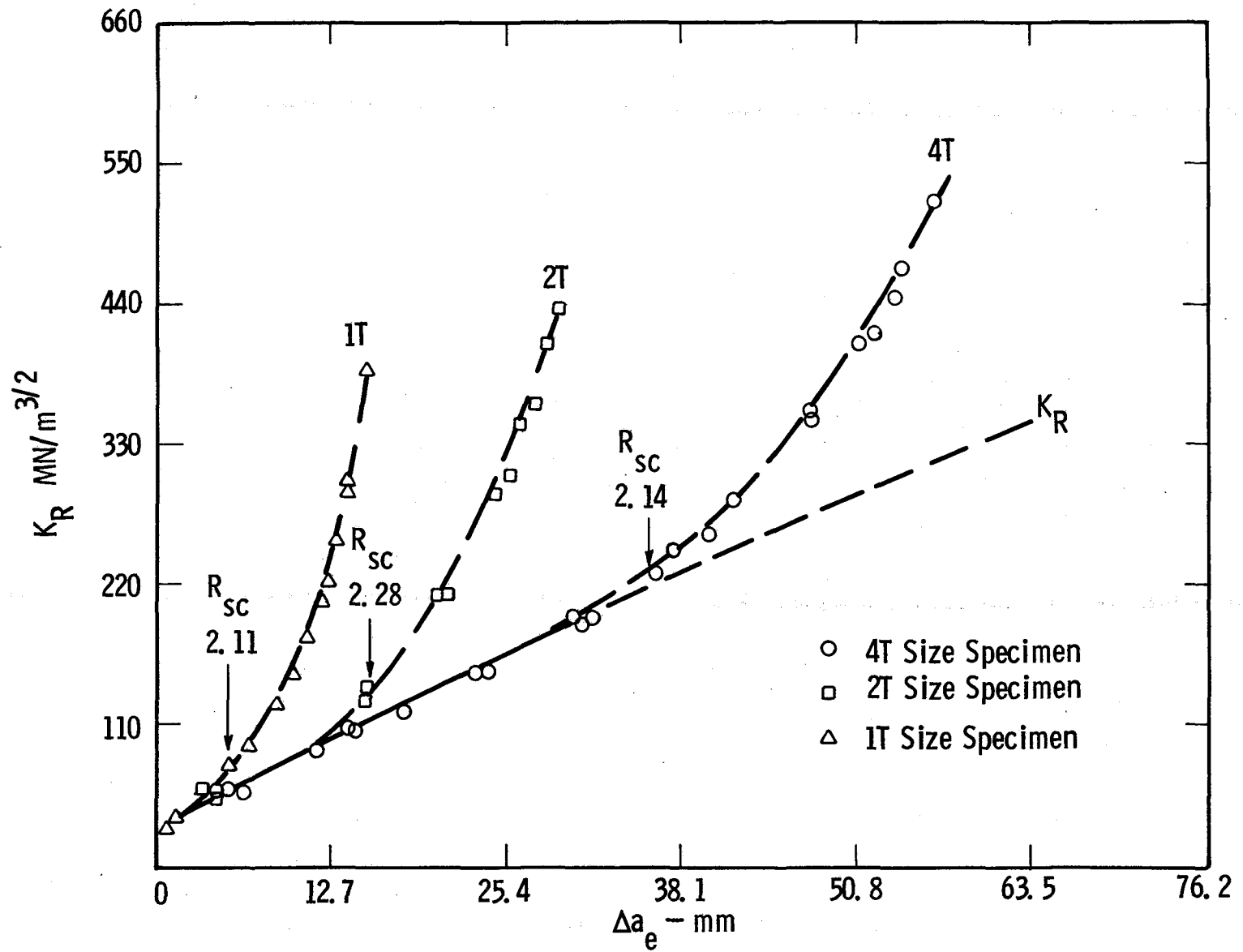

Fig. 6 - 304 Stainless

