

## General Disclaimer

### One or more of the Following Statements may affect this Document

- This document has been reproduced from the best copy furnished by the organizational source. It is being released in the interest of making available as much information as possible.
- This document may contain data, which exceeds the sheet parameters. It was furnished in this condition by the organizational source and is the best copy available.
- This document may contain tone-on-tone or color graphs, charts and/or pictures, which have been reproduced in black and white.
- This document is paginated as submitted by the original source.
- Portions of this document are not fully legible due to the historical nature of some of the material. However, it is the best reproduction available from the original submission.

JPL PUBLICATION 79-77

# Aircraft Vortex Marking Program: Final Report

Michael F. Pompa

(NASA-CR-162299) AIRCRAFT VORTEX MARKING  
PROGRAM Final Report (Jet Propulsion Lab.)  
47 p HC A03/MP A01 CSCL 01A

N79-32156

Unclas

G3/02 35789

October 1, 1979

National Aeronautics and  
Space Administration

Jet Propulsion Laboratory  
California Institute of Technology  
Pasadena, California



JPL PUBLICATION 79-77

# **Aircraft Vortex Marking Program: Final Report**

**Michael F. Pompa**

October 1, 1979

National Aeronautics and  
Space Administration

**Jet Propulsion Laboratory**  
California Institute of Technology  
Pasadena, California

## ACKNOWLEDGEMENT

Recognition and acknowledgement are given to Mr. M. A. Appel, Dr. L. H. Back and Mr. J. D. Patzold for their substantial efforts during the earlier phases of this program, which ultimately led to an advanced simplified vortex marking system. Dr. Back provided much of the analytical insight regarding the optical and physical requirements of aerosols; Messrs. Appel and Patzold performed the marker dye assessment, commercial nozzles-jet evaluation, and implemented the early steam-tetraethylene glycol work.

**PRECEDING PAGE BLANK NOT FILMED**

## List of Symbols

$b$	aircraft wing span
$T^{\circ}\text{C}$	temperature, degrees celsius
$I_o$	Intensity of incident light
$I_s$	Intensity of scattered light
$G$	scattering function
$\bar{n}$	average number density of particles
$(r_c)_m$	core radius, model
$(r_c)_{fs}$	core radius, full scale
$R$	distance from particles to observer
$(v_1)_m$	vortex maximum tangential velocity, model
$(v_1)_{fs}$	vortex maximum tangential velocity, full scale
$V_s$	scattering volume
$U$	free stream velocity
$\Gamma$	circulation of vortex flow
$\lambda$	wavelength of light
$\nu$	kinematic viscosity

## Abstract

The objective of this program was to develop a simple, reliable device for identifying atmospheric vortices, principally as generated by in-flight aircraft and with emphasis on the use of non-polluting aerosols for marking by injection into such vortex(-ices).

The refractive index and droplet size were determined from an analysis of aerosol optical and transport properties (e.g. vapor pressure, molecular weight) as the most significant parameters in effecting vortex optimum light scattering (for visual sighting) and visual persistency of at least 300 sec. The analysis also showed that a steam-ejected tetraethylene glycol aerosol with droplet size near  $1\mu$  and refractive index of approximately 1.45 could be a promising candidate for vortex marking.

A marking aerosol was successfully generated with the steam-tetraethylene glycol mixture from breadboard system hardware. A compact 25-lb<sub>f</sub> thrust (nominal) H<sub>2</sub>O<sub>2</sub> (hydrogen peroxide) rocket chamber was the key component of the system which produced the required steam by catalytic decomposition of the supplied H<sub>2</sub>O<sub>2</sub>.

## TABLE OF CONTENTS

	Page
I. Introduction -----	1
II. Initial Studies for Requirements Definition -----	2
A. Optical and Transport Properties Study -----	2
B. Atomization Methods -----	7
III. Detail Testing of Sonic Nozzle Atomizer -----	11
IV. Steam-Tetraethylene Marker System and Tests -----	23
A. ETS-Facility Supplied Steam Source -----	23
B. Engineering Model Flight System With Integrated Steam Supply -----	27
C. Engineering Model Flight System With Integrated Steam Supply and Tetraethylene Glycol -----	32
V. Conclusions -----	37
VI. List of References -----	39

PRECEDING PAGE BLANK NOT FILMED

## List of Figures

Figure No.	Title	Page
1	Sketch of Hartmann Whistle -----	10
2	Sonicore Nozzle Drawing -----	12
3	Water-Tetraethylene Aerosol Generated with Single Sonicore Nozzle -----	14
4	15 Nozzle Pattern -----	15
5	Water-Tetraethylene Aerosol Generated with 15 Nozzle Array -----	16
6	Corvus Oil Smoke Generator -----	17
7	Laboratory Test Set-up of Sonicore Nozzle Evaluation using Shadowgraph Technique -----	19
8	Sketch of Sonimist Nozzle -----	21
9	JPL Design for Aerosol Generator -----	22
10	Flow Schematic, JPL-ETS Steam-Glycol System -----	24
11	Control Test Cart and Mixing Chamber -----	25
12	Steam-Glycol Mixing Chamber -----	26
13	25 lb <sub>F</sub> Rocket Chamber, H <sub>2</sub> O <sub>2</sub> -Steam Generator -----	28
14	Detail Drawing of Modified 25lb <sub>F</sub> Rocket Chamber -----	29
15	Test Cart for H <sub>2</sub> O <sub>2</sub> -Glycol Service -----	30
16	Flow Schematic, H <sub>2</sub> O <sub>2</sub> -Glycol Systems Modified Controls	31
17	Aerosol Plume of Steam (From H <sub>2</sub> O <sub>2</sub> Catalytic Gas Generator) and Tetraethylene Glycol Mixture -----	35
18	Unmixed H <sub>2</sub> O <sub>2</sub> -Steam Jet from H <sub>2</sub> O <sub>2</sub> Catalytic Gas Generator at t = .08, .12, and .16s -----	36



LIST OF TABLES

Table No.	Title	Page
1	Comparison of Physical Properties of the Alternate Fluid with the Primary Fluid -----	7
2	Sonicore <sup>®</sup> Nozzle Operating Parameters -----	11
3	Vortex Marker Test Results, H <sub>2</sub> O <sub>2</sub> Flow Only -----	32
4	Vortex Marker Test Results with Steam and Tetraethylene Glycol Flow -----	34

## I. Introduction

The primary impetus for pursuit of the work reported upon here stems from landing safety problems of light aircraft when their flight patterns cause them to be exposed to the trailing vortices of heavy aircraft. Although on-going programs exist to reduce the vortex strength of heavy aircraft by either wing redesign or modified flap configuration procedures, vortex identification is still regarded as an option for hazard avoidance. Additionally, vortex marking is applicable as a research tool in evaluating new aerodynamic configurations, or those of proposed external appendages to the aircraft.

The objective of this program was to develop a system for providing visual marking of aerodynamic vortices by injecting tracer materials near the point of vortex origin.

An initial approach examined the optical and transport properties which affect the light scattering ability of aerosols and which will allow the entrainment and persistence of the aerosols within the trailing vortex for a sufficiently useful duration. A better understanding of aerosol dynamics could also be beneficial toward improved performance of corvus oil smoke generators which are currently being used as vortex marking agents.

A second and critical objective of this program was concerned with the design, fabrication and feasibility demonstration testing of an appropriate vortex marking system. Data derived from these tests would also serve as a design basis for flight demonstration systems.

## II. Initial Studies for Requirements Definition

The primary effort at program initiation was undertaken to clarify the basic properties which control or influence the successful production of useful aerosol mists. One approach set out to define primarily the optical and transport properties of a non-polluting vortex marker and to identify candidate marker fluids meeting these requirements. Later, the program was expanded to include a second effort aimed at developing methods and component designs to create suitable aerosols, stressing essential techniques for achieving fluid dispersal with optimum drop sizes. It was intended that the basic model and design parameters, generated as a result of these studies, could serve as criteria for design of an aerosol generator for subsequent development testing.

### A. Optical and Transport Properties Study

#### 1. Particle Requirements

As an initial consideration, this program set out to define the controlling parameters of aerodynamic vortices with the aid of scale model wing data. The primary concern was to match air circulation patterns around and behind the model and then to transfer the information as applicable to full scale aircraft sections. Based on input parameters such as: wing span, aircraft mass, velocity and geometry, this effort sought to define the necessary equations which describe vortex dynamics and longevity. In particular it was desired to simulate the full scale aircraft wake with the aid of the model such that vortex visualization by injecting liquid particles into the vortex cores would be similar for the two cases. The data would also provide test guidelines for actual developmental tests of useful hardware in subsequent program phases.

To assist in this initial task, Aerovironmental Inc. of Pasadena performed a study of this general subject of phenomological identification of vortices. Their primary findings as covered in the Reference (1) report identified the significant scaling ratios for equivalent wake dynamics (the model size as compared with full scale), and the criteria for optimum and similar luminance of the two wakes when a marking medium (dye) is injected. For a Boeing 747 full scale aircraft, the scaling ratios were determined to be as follows:

$$\text{Circulation, } \Gamma = 36 \text{ ft}^2/\text{sec}$$

$$\text{Free Stream Velocity } U = 51 \text{ ft/sec}$$

$$\text{Reynolds No. } \frac{\Gamma}{v} = 2 \times 10^5$$

$$\text{Vortex Tangential Velocity ratio } \frac{\left(\frac{v_1}{v_1}\right)_m}{\left(\frac{v_1}{v_1}\right)_{fs}} = 0.176$$

$$\text{Core radius to wing span ratio: } \left(\frac{r_c}{b}\right)_m = \left(\frac{r_c}{b}\right)_{fs}$$

The report also showed that visual appearance of full scale and model wakes would be similar for equivalent particle (marking dye) density distribution. The injection flow rate for optimum visual appearance of the model wake was reported to be approximately  $6 \text{ lb}_m/\text{min}$ .

An exhaustive study was then undertaken by Dr. L. Back (JPL) as reported in Journal of Aircraft technical paper, (Ref. 2), on light scattering capabilities of vortices and their visibility as affected by properties such as: refractive index, particle size, and vortex characteristics.

Back's approach follows G. Mie's theory (Ref. 3) on light scattering in which the ratio of intensities for scattered light ( $I_s$ ) to the wavelength of incident light ( $I_o$ ) is given by the expression:

$$\frac{I_s}{I_o} = \bar{n} V_s \left[ \frac{1}{4\pi^2} \left( \frac{\lambda}{R} \right)^2 G \right]$$

where the scattering function G is shown to be dependent upon: view angle, refractive index, and relative particle size compared to the wavelength,  $\lambda$  of incident light.

The restructured equation in terms of the mass sum of particles (involved in the aerosol) was numerically solved for the maximized non-dimensional scattering function for which it was determined to peak at particle diameters on the order of one micron.

Reference (2) went on to examine the capability of particles to persist for useful observation times as affected by particle evaporation rates and trajectories prior to linking (of the vortex pairs shedded aft of each wing tip). On the basis of quasi-steady state, diffusion controlled, evaporation of binary vapor mixtures (with air as one of the components), it was found that for vapor pressures near  $1 \times 10^{-5}$  mm Hg, persistency periods near 300 s could be achieved starting with 1 $\mu$  diameter droplets. This time regime also agrees with Back's order of magnitude estimate of the vortex elapse time (persistence) to linkage, as was confirmed from large-aircraft tests where a range from 40 to 120 s was experienced for heavy aircraft configurations from  $(100 \times 10^3$  to  $800 \times 10^3$  lb<sub>m</sub>), and formed a basis for allowing a factor of safety in the selected droplet persistence time of 300s.

Thus, the apparent conclusion reached from Back's paper generally states that to generate applicable aerosols, the search for useful marking agents should require the following property levels.

- i. Particle diameter on the order of  $1\mu$  and refractive index of 1.5 required for maximum light scattering.
- ii. Low vapor pressure ( $1 \times 10^{-5}$  mm Hg) and larger molecular weight (near 200) required for 300 sec persistence.
- iii. Marker material should be hygroscopic and non-toxic.

## 2. Evaluation of Candidate Marker Material

A search for a suitable marker material or materials, was conducted which included screening of approximately 168 solid and 1200 liquid compounds. Of the solid compounds examined, all of the inorganic class were eliminated because of the toxicity. The following group of eight organic solids were identified of which the first group of four are used as food additives and the second group of four are only slightly toxic.

### Food additive solids:

- i. adipic acid
- ii. azelaic acid
- iii. lauric acid
- iv. stearyl alcohol

### Slightly toxic solids:

- i. benzoic acid
- ii. Benzyl cinnamate
- iii. Benzoic anhydride
- iv. anthraquinone

Continued studies of solid particle candidates resulted in eventual elimination of this particle class owing primarily to the fact that they can easily become explosive hazards and would require a complex delivery system. A further disadvantage was related to tendencies of solid particles to agglomerate during milling; this agglomeration would further complicate the production and delivery of proper particle sizes.

The evaluation of the liquid candidates resulted in identifying five compounds which met the requirements for marking fluids as previously mentioned. These materials were the following:

- i. diethylene glycol-bis-chloroacetate
- ii. tetraethylene glycol chlorohydrin
- iii. enanthophenone (damascenone)
- iv. tetraethylene glycol
- v. tripropylene glycol

The first two compounds are basically laboratory mixtures and thus are not available commercially; the third item is used as a cardioplegic and also not available commercially. It was decided to proceed with developmental testing using tetraethylene glycol which is used primarily as an industrial coolant or freezing point depressant, and to delegate the tripropylene glycol as an alternate material. Table 1 shows the physical properties of the selected glycol materials.

Toxicity studies on these glycols by the manufacturer (Union Carbide) has shown them to be of low order toxicity - as a class, except for oral intake, which must be avoided. cursory material compatibility evaluations were conducted on painted (baked enamel) exterior surfaces

during which a 2-week exposure to tetraethylene glycol evidenced no degradation. It was concluded that there are minimal or no deleterious effects on materials, the atmosphere, or personnel from exposure to glycol solutions.

Table 1. Comparison of Physical Properties of the Alternate Fluid with the Primary Fluid

Physical Property	Alternate Tripropylene Glycol	Primary Tetraethylene Glycol
Chemical Formula	$C_9 H_{20} O_4$	$C_8 H_{18} O_5$
Molecular Weight, gram/gram-mole	192.3	194
Boiling Point at 760 mm Hg, °C	272.9	307.8
Freezing Point, °C	-45	-4
Vapor Pressure (20°C), mm Hg	$4.68 \times 10^{-3}$	$1.17 \times 10^{-5}$
Temperature at Which Vapor Pressure is $10^{-5}$ mm Hg, °C	-35.6	18.7
Specific Gravity	1.102	1.125
Refractive Index	1.45 (Est.)	1.45
Solvents	$H_2O$	$H_2O$

## E. Atomization Methods

A survey study was conducted to evaluate and specify methods and components for application to aerosol production using the criteria discussed below as a basis for selecting those techniques with a high premise of success. Clearly, a useful aerosol generator should be capable of producing large particle number density of one micron particles based on the earlier studies noted above, and be capable of being integrated within a compact



simple delivery system for high reliability. Novel concepts were also considered so that viable alternatives would be available in the event that acceptable performance was not attainable with commercial items. Following are several prominent atomizing concepts and methods which were evaluated by analysis and/or testing.

1. Impinging Liquid Jets

This method is capable of generating 100-micron droplets and is commonly used in rocket engine injectors. It has excellent capability of producing repetitive jet configuration and drop sizes with each application. Due to its simplicity, it has a high potential for weight-sensitive systems.

2. Impinging Gas/Liquid Jets

These systems are approximately equivalent to impinging liquid jet systems regarding drop sizes produced. Their application has seen some exposure in rocket and diesel engine combustion where the prior vaporization of one of the propellant components may contribute to better thermal efficiencies.

3. Piezoelectric Ultra Sonic Atomizer

These atomizers are capable of producing desired drop sizes near one (1) micron; however, the system can become complicated with its associated electronics and controls. Most of these atomizing systems are used for domestic and light industry application (paint spraying, etc.), and are not especially weight effective for flight application.

4. Spinning Wheel Atomizer

This method has the potential for generating one (1) micron droplets, although both wheel diameter and operating RPM must be large in order to achieve the desired drop size.

5. Sonic Nozzle Atomizers

These devices have been used to produce jets and mists in the range of 0.1 to 10 microns, and their application is found in several commercial/industrial fields, including food processing environmental control, medical therapy and combustion. They are simple to operate and require only minimal support hardware, and as such, have good potential for incorporation in lightweight flight system designs. A significant level of testing was performed under this program on such sonic devices, and is covered later in this report.

Essentially these devices, often referred to as Hartmann acoustic generators, employ high pressure air, ( $\approx 50$  psia) flowing through a nozzle to create a sonic field. The air is directed into a hollow cavity chamber downstream of the nozzle exit causing it (cavity) to resonant such that the reflected pressure field creates a sonic shock which vibrates in a narrow band. Liquid is injected through orifices into the shock band, and thus becomes atomized. Droplet size is dependent upon cavity configuration (frequency), liquid flow-rate and viscosity. A schematic diagram of the Hartmann whistle (sonic generator) is shown in Figure 1.

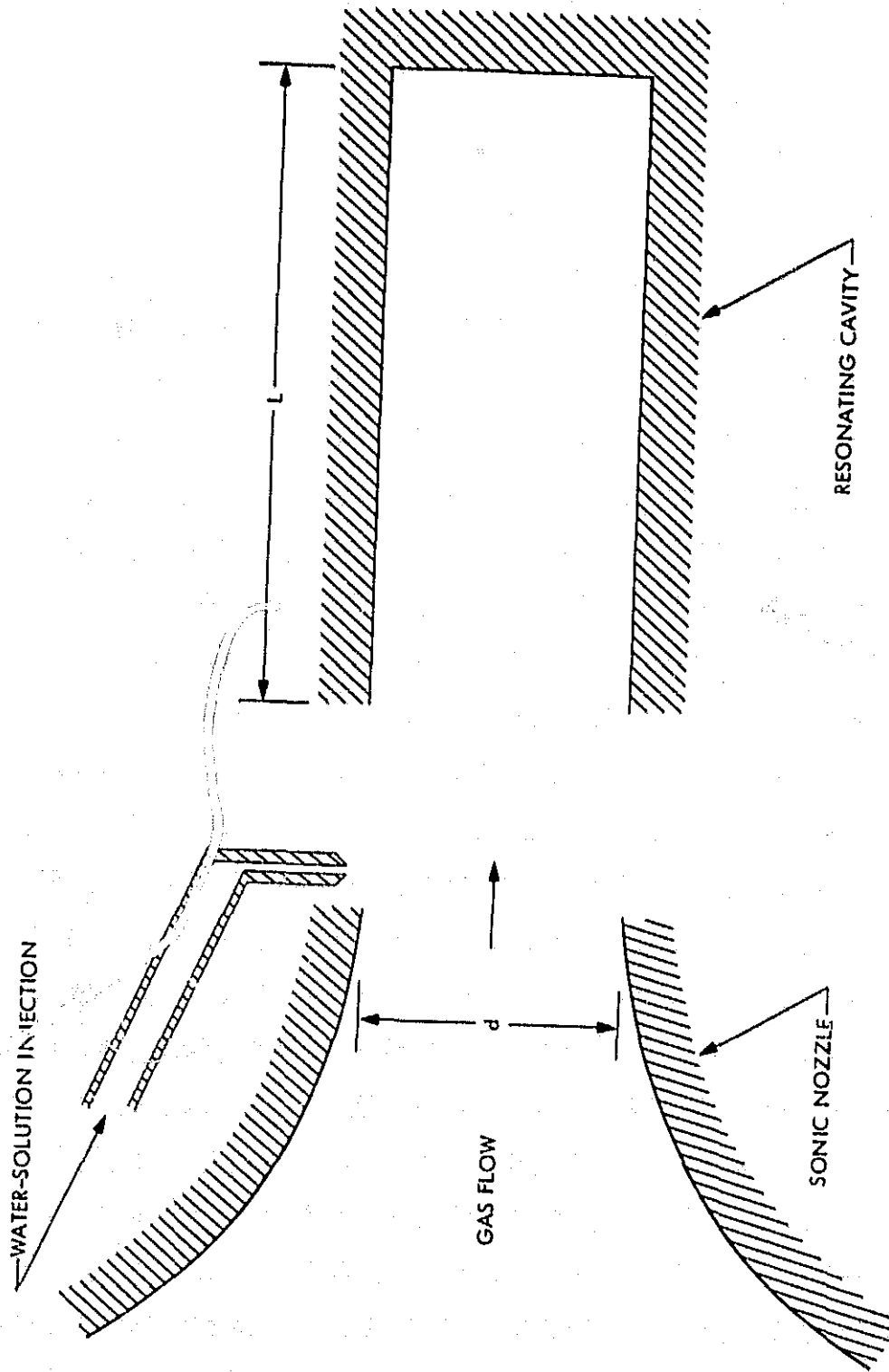

Figure 1. Sketch of Hartmann Whistle

### III. Detail Testing of Sonic Nozzle Atomizers

A development test program was initiated to verify the preliminary aerosol models that were developed through the earlier study effort and to functionally evaluate their application to vortex marking. The sonic nozzle (Hartmann whistle) was selected for testing as an aerosol generator, using tetraethylene glycol and water mixtures at various mass flow rates and gaseous nitrogen pressures. This aerosol generator configuration was chosen for its simplicity and wide-spread use in the industrial combustion of hydrocarbon liquid fuels, as well as its ready availability as a commercial item.

Using the Sonicore<sup>1</sup> nozzle configuration it was determined that a 15-nozzle array would satisfy the fluid mass flow requirements identified in flight tests at Edwards Test Station (JPL) using Corvus oil generators. Figure 2 is a drawing of a typical Sonicore<sup>®</sup> nozzle whose nominal envelope dimensions range from 1 to 2 inches diameter and 2 to 4 inches length, depending on the application. Two nozzle configurations were obtained, whose characteristics are as shown in Table 2 below.

Table 2. Sonicore<sup>®</sup> Nozzle Operating Parameters

Nozzle Designation	Vol. Rate, H <sub>2</sub> O GPHr	Pres, N <sub>2</sub> PSIG	Rated Average Particle Size Spray Capability
035H	1.2	55	Submicron to 10 $\mu$
052H	2	80	Submicron to 10 $\mu$

These nozzles were evaluated for their flow vs. pressure drop performance, visually checked for the adequacy of the resultant aerosol configuration, and the data was used to select which specific nozzle type would

<sup>1</sup>Registered trademark of the Sonic Development Corporation, Upper Saddle River, New Jersey.

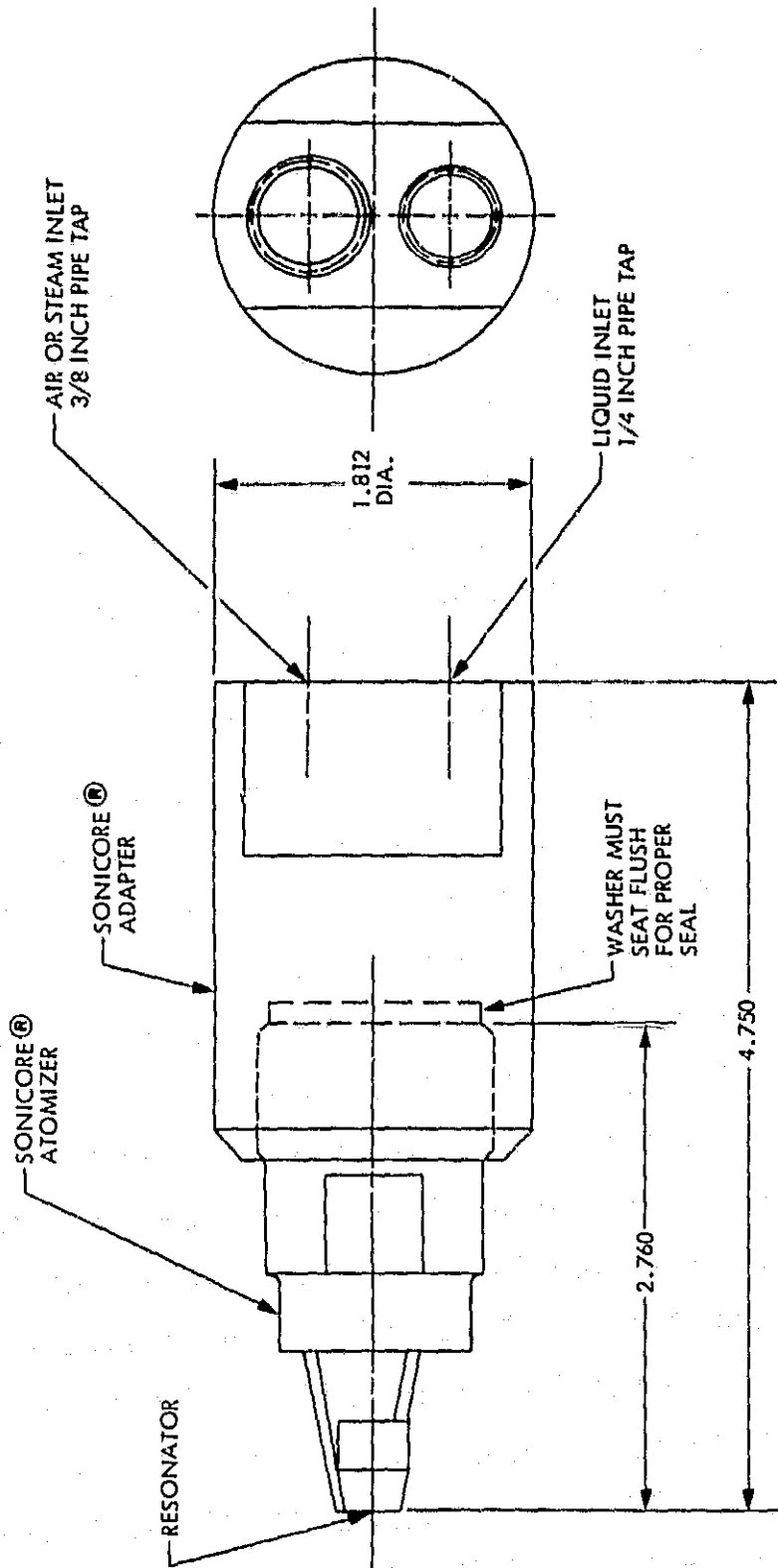

Figure 2. Sonicore<sup>®</sup> Nozzle Drawing

compose the 15-nozzle array. Figure 3 shows a typical aerosol generated with a Sonicore<sup>®</sup> nozzle and using water-glycol fluids. The reassuring results obtained from these initial tests indicated an even greater expectancy of success at the 15-nozzle level.

The 15-nozzle cluster, configured as shown in Figure 4, was initially tested at JPL-Pasadena at reduced flow rates to avoid possible atmospheric contamination problems, using nominal N<sub>2</sub> pressures at 50 to 80 psig and also with added small percents of surfactants to assess their affect on surface tension and attendant aerosol visibility. The resultant aerosols were judged to have good visibility, with indications that even better visibility may be obtained with the full mass input rates. Continued testing was carried out at JPL-ETS using design flow rate, i.e.; 2-6 G/hr, and indicated inadequate visibility (light scattering) compared to the aerosols generated at Pasadena. A typical aerosol configuration produced by the 15-nozzle cluster is shown in Figure 5. A first order qualitative ranking of the aerosol from this 15-nozzle-cluster was obtained from juxtaposed testing with a Sanders corvus oil smoke generator (Figure 6) - a state of the art generator currently used for aircraft wake vortex marking. The results showed the 15-nozzle Sonicore<sup>®</sup> array to be definitely less visible.

As a diagnostic measure, laser beam apparatus from the Laser Holograph Co. (Santa Barbara, CA) was made available to record the aerosol droplets for later sizing. In the operation of this optical equipment, a pulsed laser beam is generated and directed through the aerosol causing the shadowed image of droplet particles to be contrasted upon a receiving optical sensor. Magnetic tape records of the images were played back

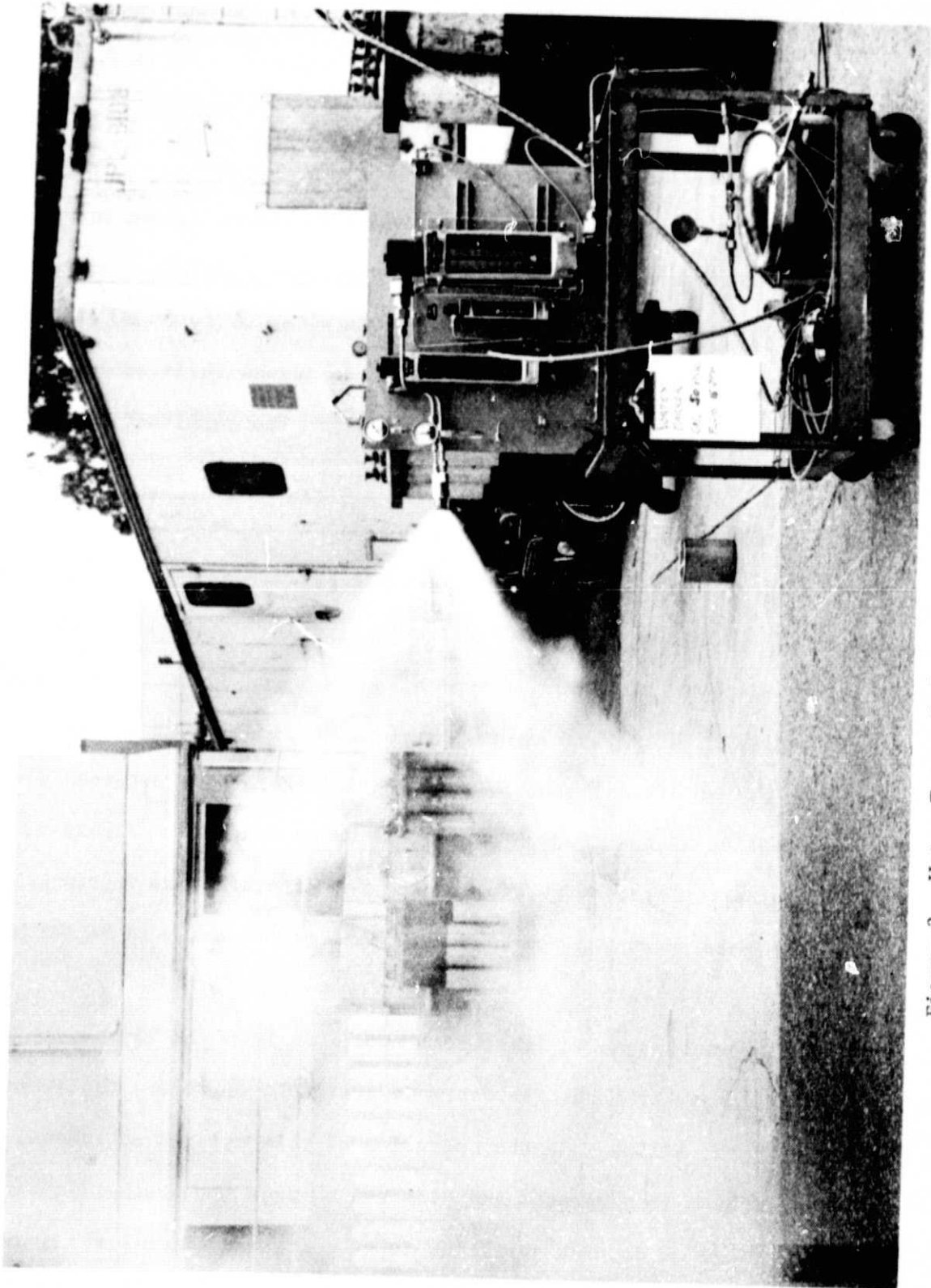

Figure 3. Water-Tetraethylene Aerosol Generated with Single Sonicore® Nozzle

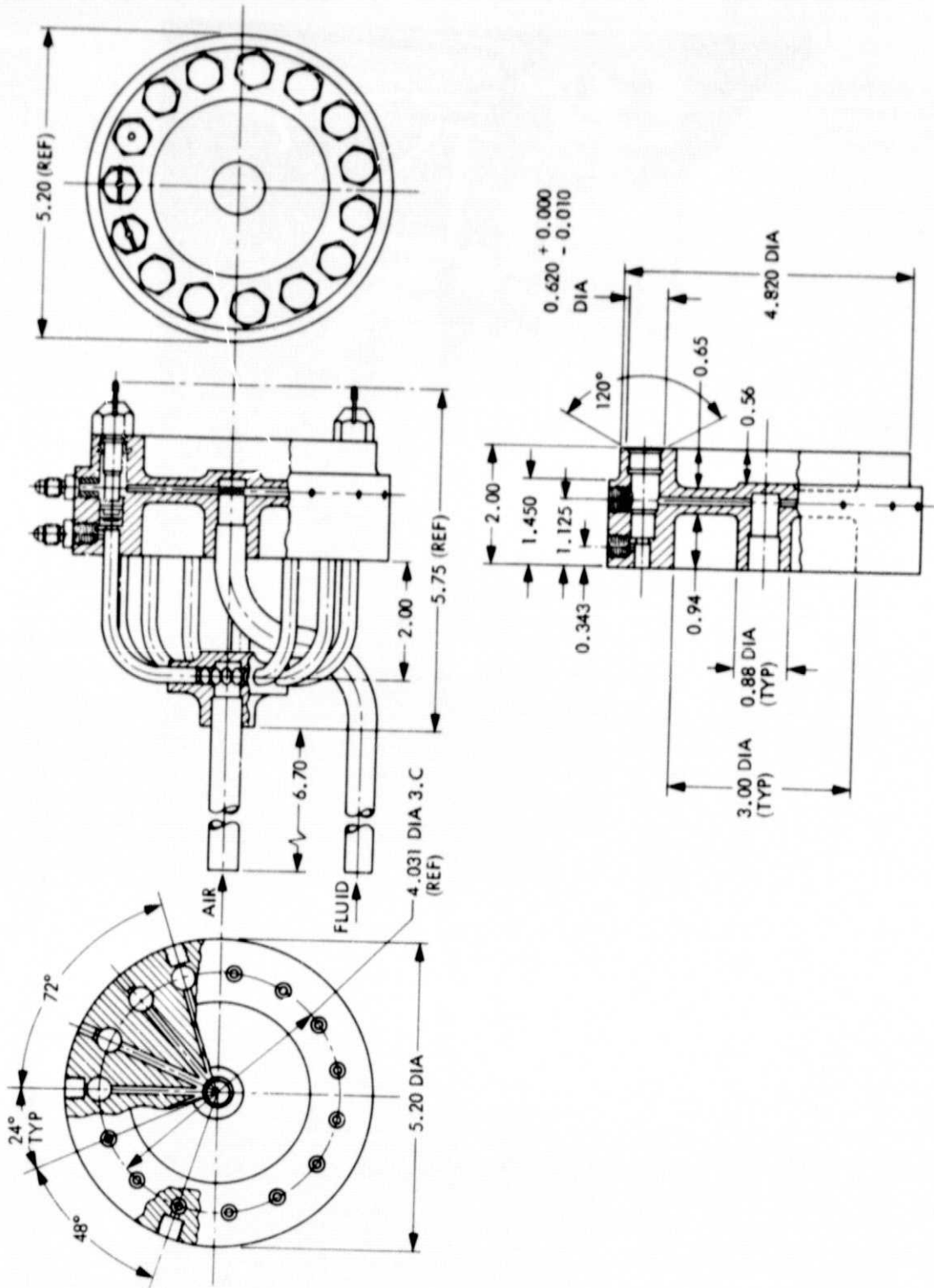

Figure 4. 15-Nozzle Pattern (from JPL Drawing 10076657)



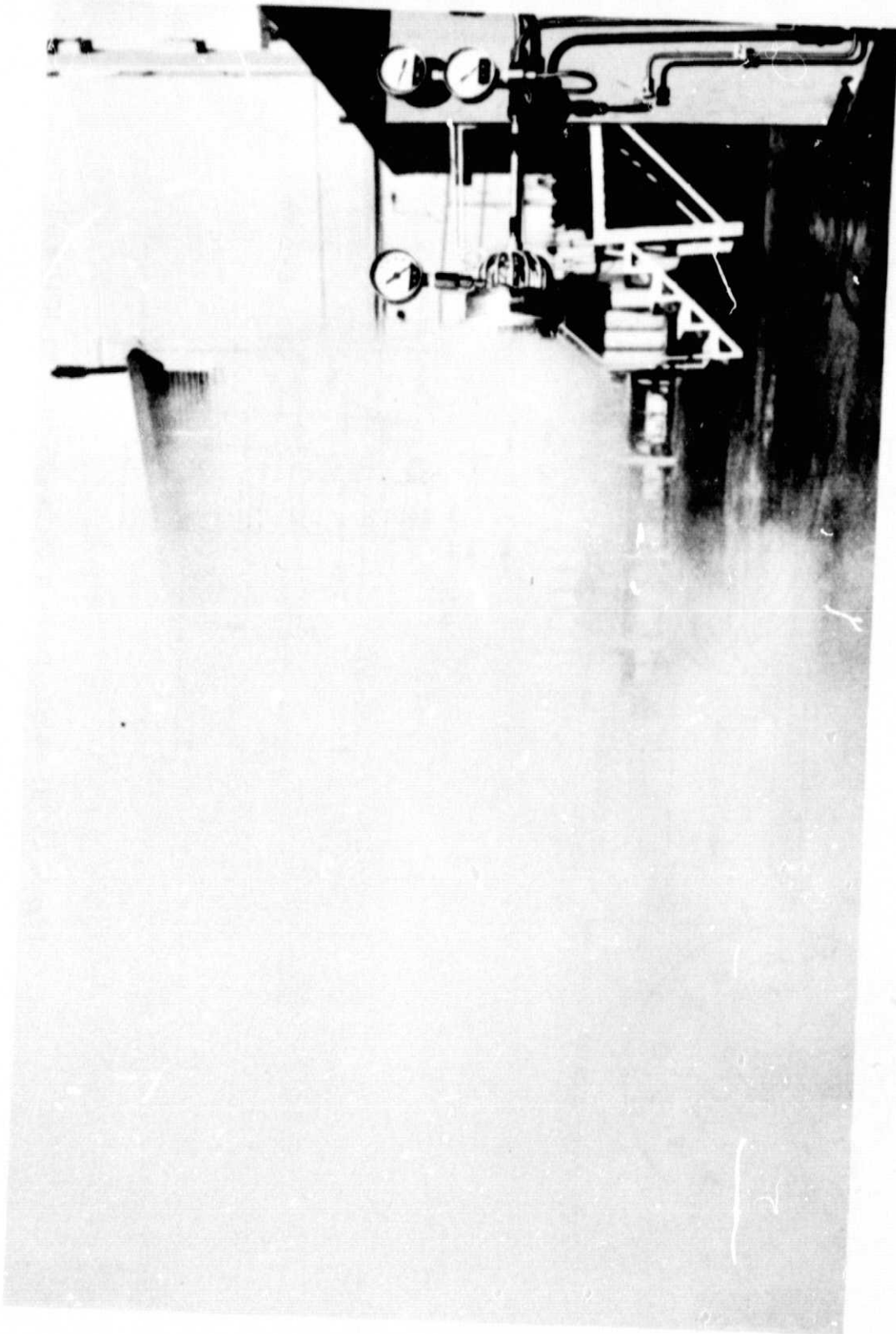

Figure 5. Water-Tetraethylene Aerosol Generated with 15-Nozzle Array



Figure 6. Corvus Oil Smoke Generator

ORIGINAL PAGE IS  
OF POOR QUALITY

later to obtain actual ruler dimensions of the "frozen" images. An average aerosol diameter of 1 micron was obtained from run tape data evaluation for some of the droplets as was expected from nozzle vendor literature on their product (nozzle) capability in generating aerosols of particular particle diameters. However, the shadowgraph data also shows there were an overwhelming number of drops far greater than 1 micron diameter so as to cause the resultant aerosol to be poorly visible. It was postulated that flow rates far in excess of 2 to 6 GPHr might produce a sufficient number of 1-micron particles such that the resultant aerosol may become more visible; however, this concept was not tested because the resultant weight penalty of added system fluids and containers would be prohibitive.

A detailed laboratory evaluation was then undertaken on individual Sonicore<sup>®</sup> nozzles as described in detail in Reference 3, to help provide some basic insight for performance improvements. Instant spark shadowgraphs as well as motion pictures of nozzle jet flow were taken using an electric "strobtac". Flash duration of the strobtac was less than 3 microseconds which was short enough to freeze the flow field. The stationary shock structure caused by the expanding gas ( $N_2$  or He) could be photographed by adjusting the strobtac flash rate to be coincident with the shock oscillation frequency. Also by adjusting the flash rate to be near, but not equal to, the shock frequency, a slow motion replica of the shock dynamics could be observed. A schematic diagram of the test set-up is shown in Figure 7. Note the presence of the microphone pick-up which recorded the sound pressure levels produced, above the ambient pressure by the Sonicore<sup>®</sup> nozzles. Basically, this investigation yielded the following significant data:

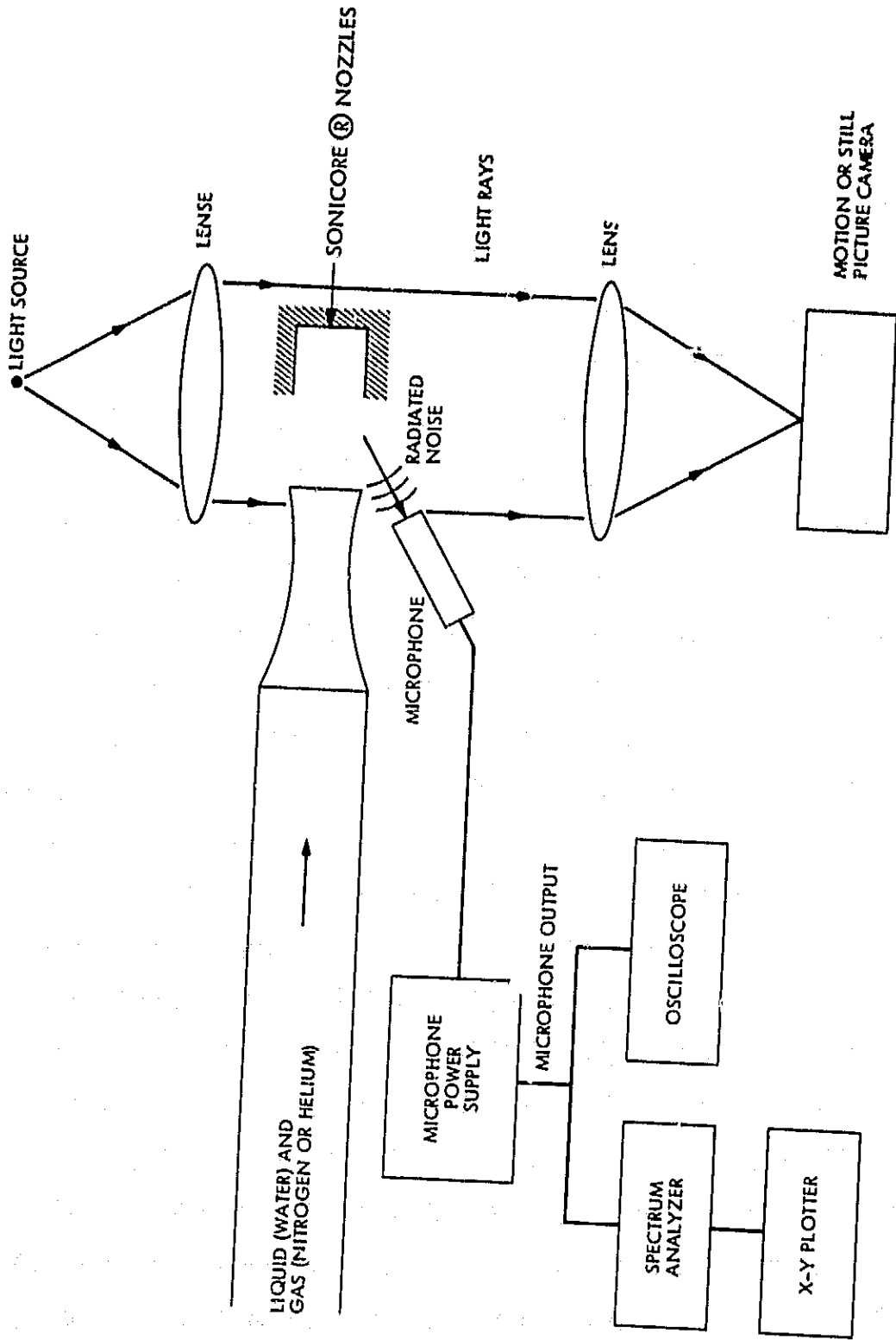

Figure 7. Laboratory Test Set-up of Sonicore<sup>®</sup> Nozzle Evaluation using Shadowgraph Technique

- a. Jet spreading was a function of upstream pressure (strength of the shock) and resonator cavity alignment.
- b. As the shock became more unstable, better liquid break-up was produced.
- c. Good atomization appears to be related to the unsteady pressure field of the oscillating shock and the high jet shear action at the jet boundary.

The results of this study also seemed to suggest that opposing jets could provide even further increase in dispersal of the number of 1-micron size particle droplets produced.

A further study evaluation was also undertaken of a slightly different sonic nozzle configuration produced by Heating Systems Ultrasonics Inc., (Plainview L.I., N.Y.) trade-named Sonimist. This nozzle configuration was pursued because it seemed to have much of the prerequisite qualities described in the Reference 3 study. A model 900-2 Sonomist <sup>TM</sup> nozzle (see Figure 8) was obtained and tested at similar input conditions as the previous Sonicore <sup>R</sup> nozzles. The resultant spray drop size was judged to be up to desired performance, and therefore all evaluation of single sonic nozzle induced jets was terminated.

An in-house configuration was then designed incorporating some of the indicated principles resulting from the laboratory testing (Reference 3); this design is shown in Figure 9. Shortly thereafter, program emphasis was redirected to the steam-tetraethylene concept, so that jet evaluation of the configuration of Figure 9 was never carried out.

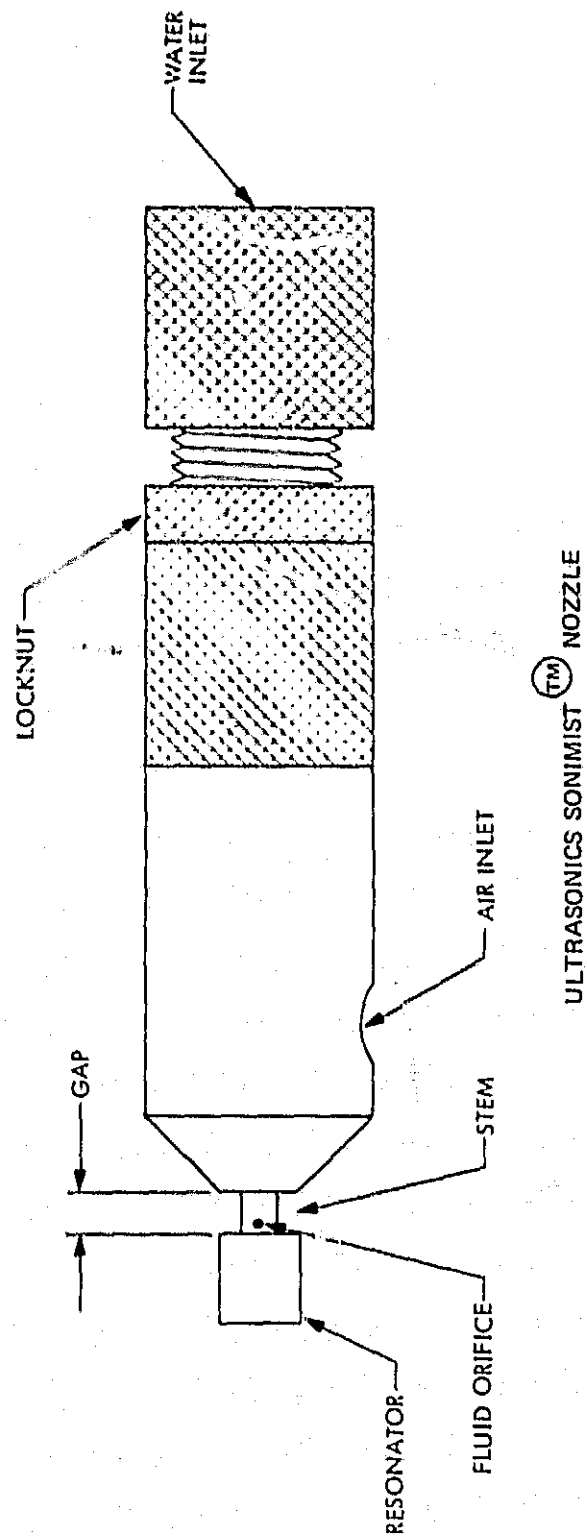

Figure 8. Sketch of Sonimist™ Nozzle

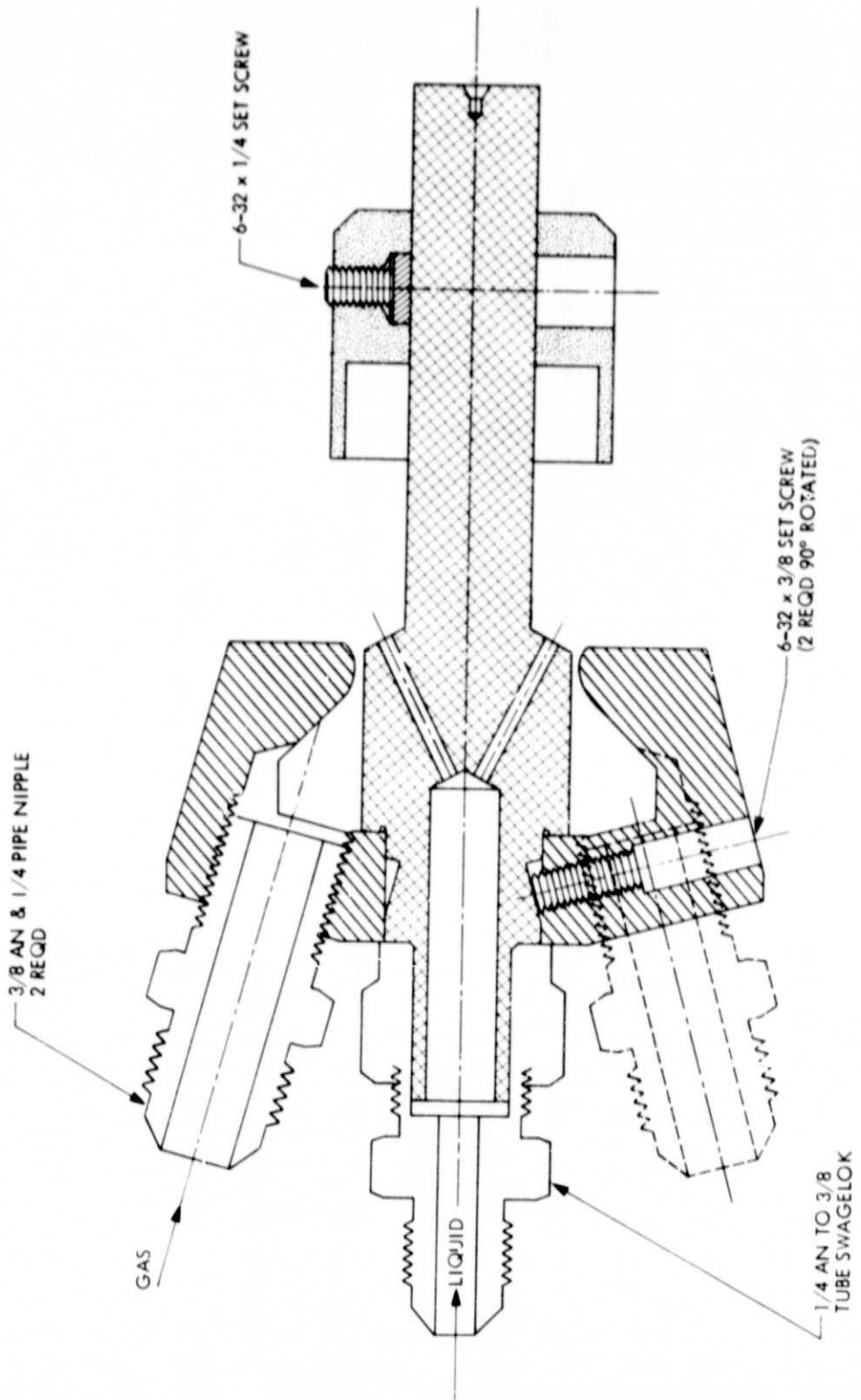

Figure 9. JPL Design for Aerosol Generator

#### IV. Steam-Tetraethylene Marker System and Tests

##### A. ETS Facility Supplied Steam Source

The decision to evaluate a steam-tetraethylene marker system was prompted by the realization that for nearly constant-low pressure systems, a source of heat would be needed in order to achieve thorough vaporization and dispersal of the aerosol over a broader area. Superheated steam was selected as the heat source, and specifically, to incorporate a rocket-type  $H_2O_2$ -steam generator as a compact source of superheated steam. Due to the potential scheduling problems involved with acquiring a  $H_2O_2$ -steam generator component, it was decided to postpone such tests and proceed immediately with the use of ETS-facility vacuum-steam to demonstrate the glycol-superheated steam aerosol.

A test configuration was assembled for this purpose at JPL-ETS. Figure 10 is a schematic flow diagram of the test set up. An actual photograph of the control plumbing test cart and steam-glycol mixing chamber is shown in Figure 11. In this figure the steam supply arrives from the center right (horizontal) pipe, and glycol enters through the rotameters (center left) to the 2-point injection plane of the mixing tube. The screen-pack mixing tube is shown in Figure 12 where the steam and glycol were mixed. It is noted that relatively simple residual components (available from previous programs) were used consisting of primarily manual control components and visual gages. Flow in this photograph is generally to the left.



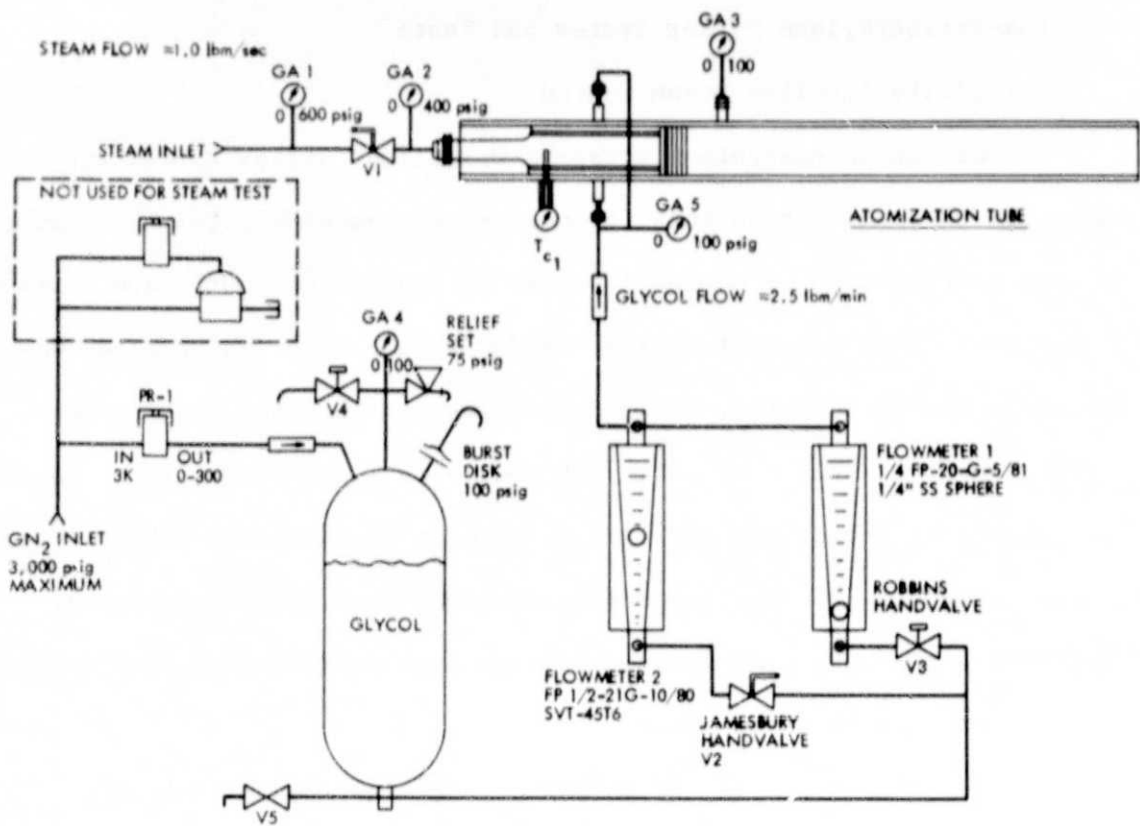

Figure 10. Flow Schematic, JPL-ETS Steam-Glycol System

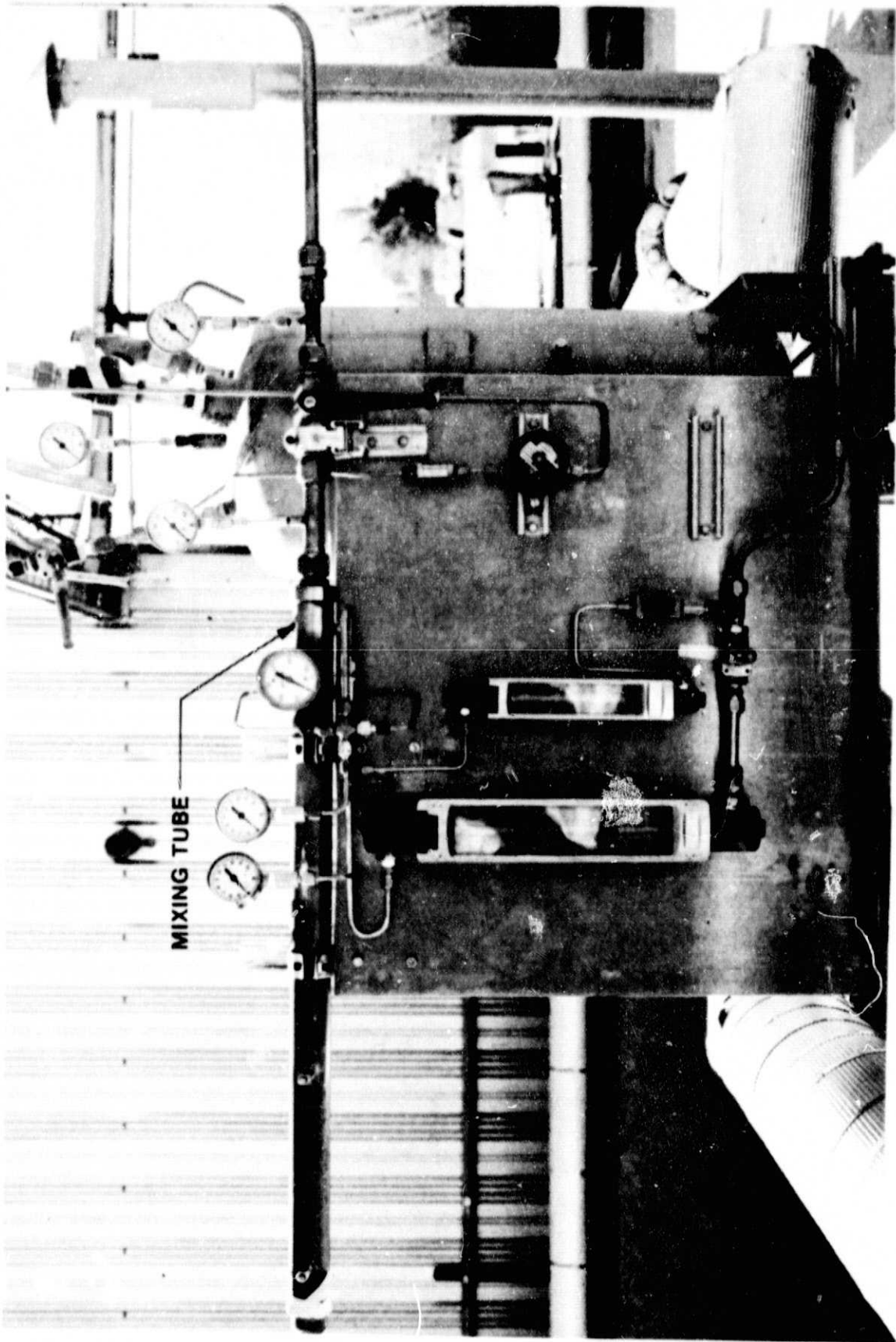

Figure 11. Control Test Cart and Mixing Chamber

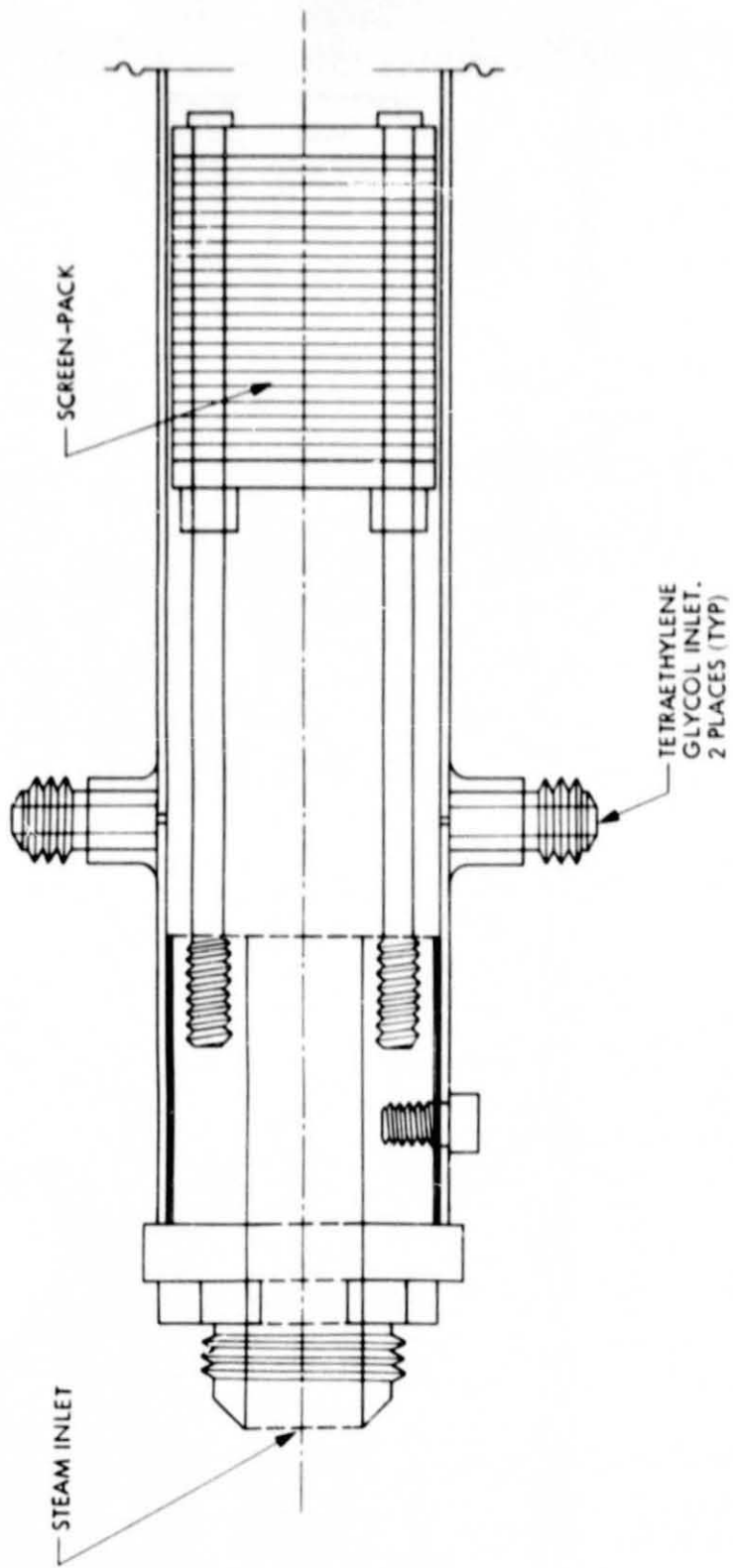

Figure 12. Steam-Glycol Mixing Chamber

The flowrates for these tests were as follows:

$2.84 \frac{\text{lb}_m}{\text{min}}$ , glycol solution (88 percent tetraethylene glycol and 12 percent water)

$28.2 \frac{\text{lb}_m}{\text{min}}$ , steam

These flowrates were based on delivered steam conditions of 20 psia and 320°F with the expected heat available in the expansion to be about 30 Btu/lb<sub>m</sub> of steam.

Approximately six (6) tests were performed with extremely encouraging results. The resultant plumes were very visible, being a rich whitish color.

### B. Engineering Model Flight System with Integrated Steam Supply

In due time a 25-lb<sub>f</sub> thrust (nominal) H<sub>2</sub>O<sub>2</sub> steam generator was obtained from residual ETS hardware and its use led to aerosols of improved visibility. To effect interface compatibility with the previously used steam-glycol mixing tube, this thruster required some modifications, photographs of which are shown in Figures 13; engineering design details of the modified H<sub>2</sub>O<sub>2</sub>-generator are also shown in Figure 14 (JPL Drawing 10087493). The test set-up to incorporate the H<sub>2</sub>O<sub>2</sub> steam generator consisted of appropriate modifications to the set-up previously used with Facility steam (refer to Figures 10 and 11). The results of this modification are shown in the photograph of Figure 15 and schematically in Figure 16.

Operating parameters for the H<sub>2</sub>O<sub>2</sub> system were derived by determining the heat required to vaporize 2.84 lb<sub>m</sub>/min (nominal) of the tetraethylene



Figure 13. 25 lb<sub>F</sub> Rocket Chamber, H<sub>2</sub>O<sub>2</sub>-Steam Generator

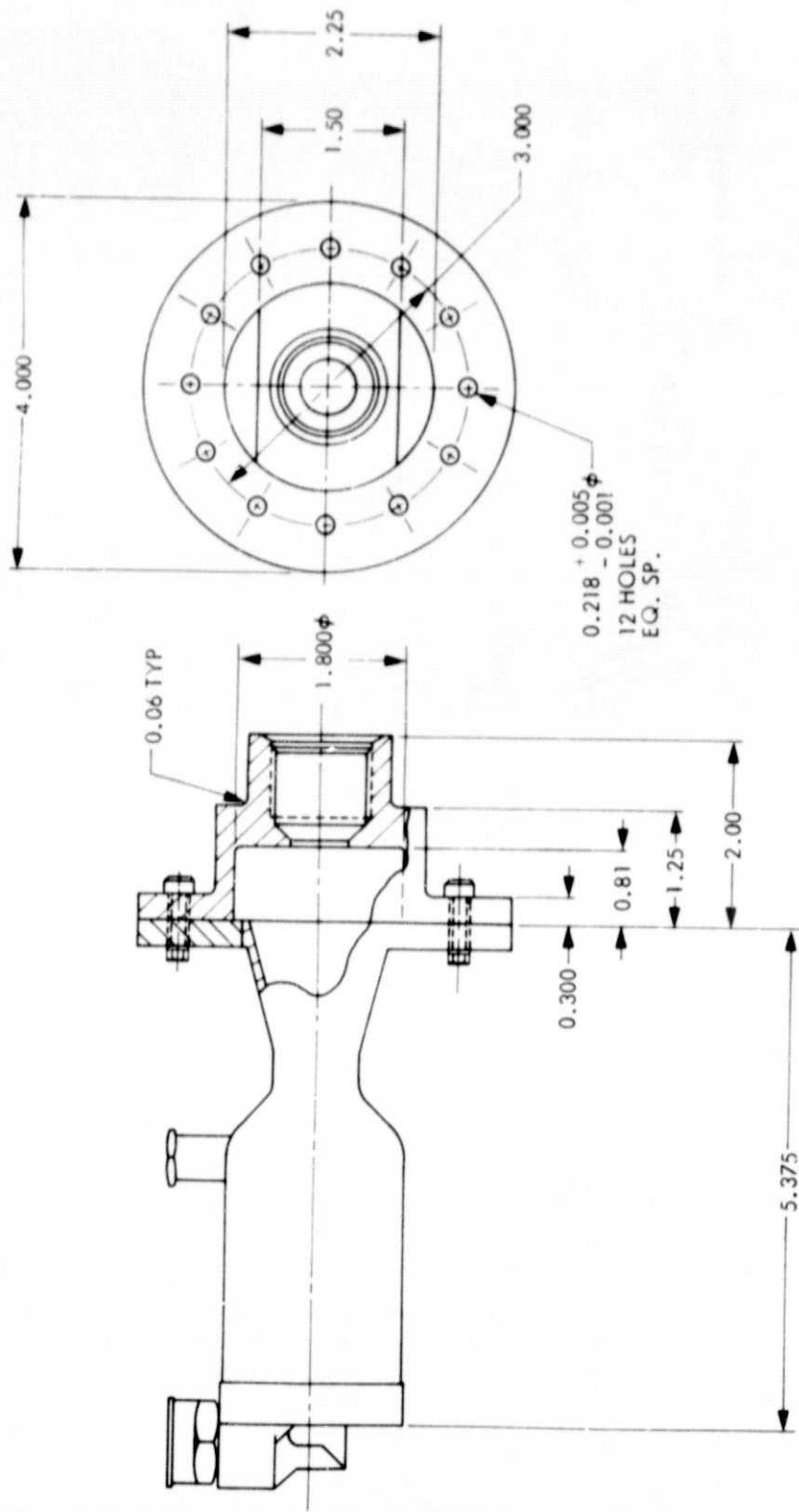

Figure 14. Detail Drawing of Modified 25lb<sub>F</sub> Rocket Chamber

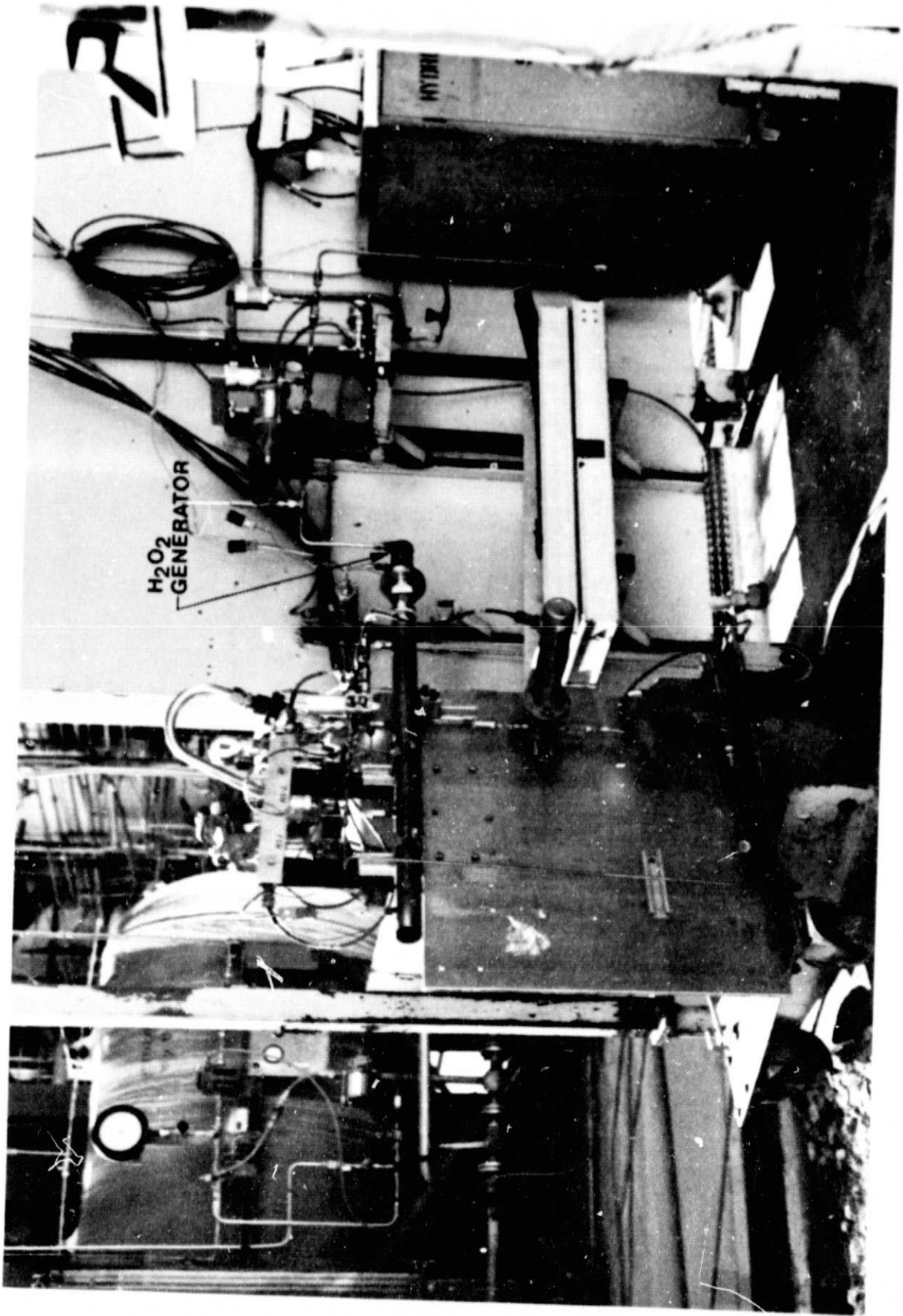

Figure 15. Test Cart for  $H_2O_2$ -Glycol Service

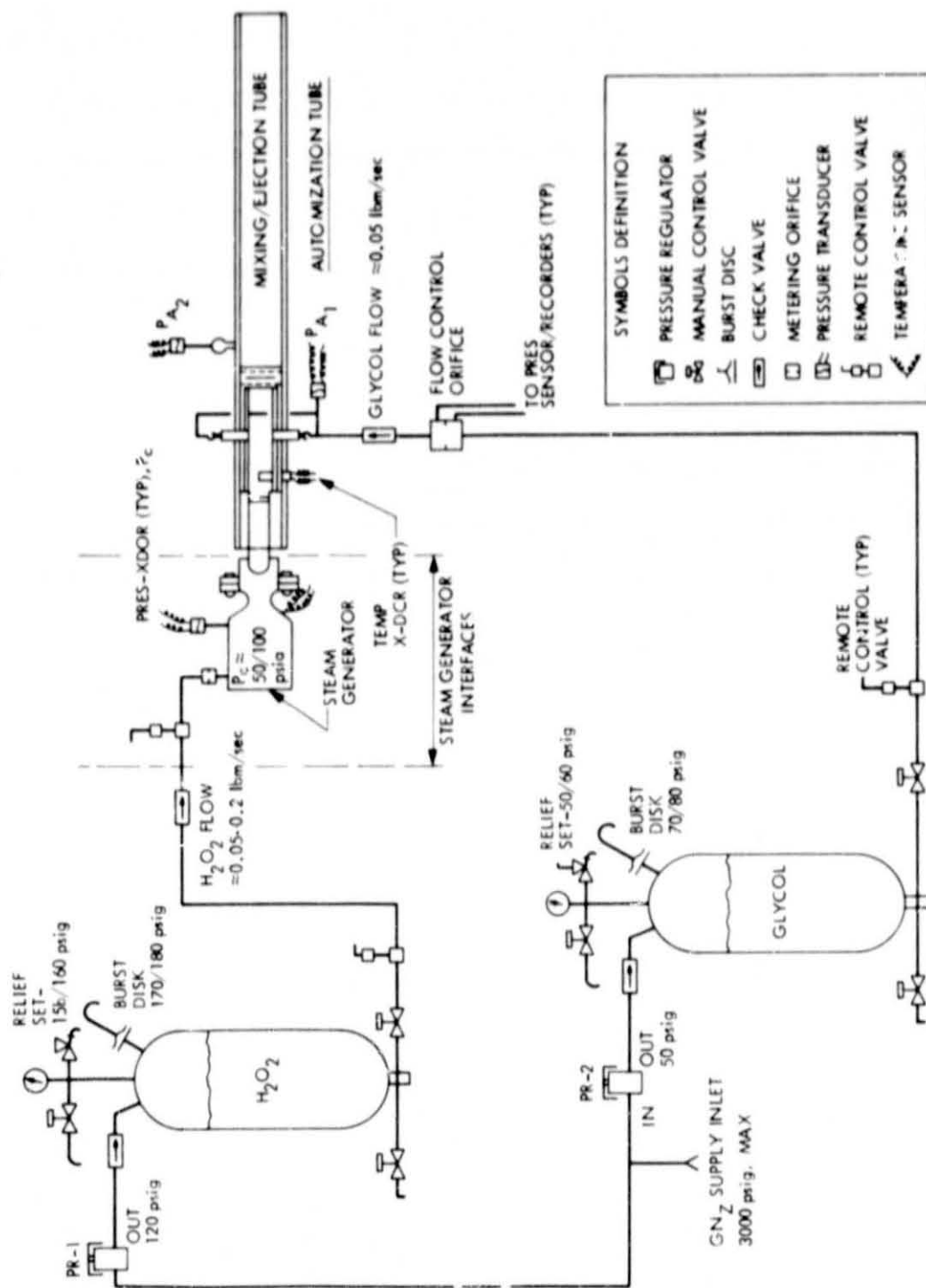

Figure 16. Flow Schematic, H<sub>2</sub>O<sub>2</sub>-Glycol Systems Modified Controls



glycol-water solution which was of similar glycol flow rate as used in the predecessor system with facility steam. Mollier diagrams for 80 and 90 percent purity  $H_2O_2$  were used in these calculations. The results indicated that  $H_2O_2$  flow-rates of 3.0 to 18  $lb_m/min$  should be adequate.

C. Engineering Model Flight System with Integrated Steam Supply and Tetraethylene Glycol

This testing was conducted sequentially in two parts. The first part consisted of hot flowing of the system with only  $H_2O_2$  supplied to the steam generator, i.e., no tetraethylene glycol was used. The purpose of this series of tests was to verify the capability of the steam generator to decompose  $H_2O_2$  into steam. A group of five (5) tests were performed yielding satisfactory results and confirming the suitability of the generator catalyst bed. Pressures, temperatures and flowrates for these tests are shown in Table 3.

Table 3. Vortex Marker Test Results

$H_2O_2$  Flow Only

Test No.	Mass $H_2O_2$ $lb_m/min.$	$P_c$ psig	$t_B$ s	$T_N$ $^{\circ}F$	$C^*$ ft/s
DV002A	6.72	32	51	340	3550
DV001D	14.1	66	25	415	2400
DV001E	14.8	78	30	415	2670
DV001F	5.28	18	40	375	2520
DV001G	17.1	90	40	464	2516

The plume observed had a light white color and was clearly visible against a clear atmosphere background which indicated marginal superheating of the  $H_2O_2$ . When there were no winds, the plume configuration was roughly 25 feet long by 10 feet in diameter; and with about a 10 to 15 mi/hr head wind, the plume length was reduced to approximately 10 feet. Low quality superheating from the  $H_2O_2$  steam generator can also be inferred from the relatively low nozzle throat temperature ( $\approx 2400^\circ F$ ) and the low value of characteristic exhaust velocity ( $\approx 2600$  ft/sec). The primary causes for this inefficiency, e.g., spent catalyst bed, improper injection velocities, and/or injection pattern/distribution, could not be pursued within the program scope and available limited data, although the evidence is sufficient to allow concluding that the steam generator was not operating in an efficient manner. Nonetheless the size and persistency of the observed plumes provided encouragement to proceed with the combined  $H_2O_2$ -tetraethylene glycol tests. Note also that the  $H_2O_2$  mass flowrates were approximately 1/3 to 1/2 of those used in the initial tests from the ETS-facility vacuum-steam indicating a higher degree of the superheating was achieved in latter tests.

The dynamics of two other characteristics were observed which could be useful for future design, i.e.: 1) nozzle temperatures attained steady-state in about 15 sec from start switch "ON" and 2) a short period of 10 minutes was required for the generator to cool-down to  $100^\circ F$  after shutdown.

The second part of this test program included tetraethylene input at the mixing ejector tube along with superheated steam supplied from  $H_2O_2$  decomposition in the gas generator. The resultant aerosol had a rich white

appearance, and was easily visible against the atmospheric background as shown in Figure 17. Typical of the characteristic unmixed steam -  $H_2O_2$  jets, obtained at run start-up (prior to addition of tetraethylene glycol) is the jet sequence shown in Figure 18. The significant operating levels of these tests are shown in Table 4.

It is noted that these tests yielded  $H_2O_2$ -to-glycol mixture ratios of 2.3 to 2.7 which are approximately one order of magnitude less than had been predicted. Also, for the tests reported above, the nozzle temperature was approximately twice that obtained during earlier tests with only  $H_2O_2$  flow. This is a strong indication of erratic behavior of the  $H_2O_2$ -steam generator and a need for quality gas generators in a continuing development program for vortex marking.

Table 4. Vortex Marker Test Results with Steam and Tetraethylene Glycol Flow

Test No.	Mass Flow lb <sub>m</sub> /min		P <sub>c</sub> psig	t <sub>B</sub> s	T <sub>N</sub> °F
	H <sub>2</sub> O <sub>2</sub>	Glycol			
DV002	7.8	2.8	42	20	848
DV002A	7.8	3.0	40	25	780
DV002B	7.8	3.2	33	25	750
DV002C	5.6	3.3	23	25	780

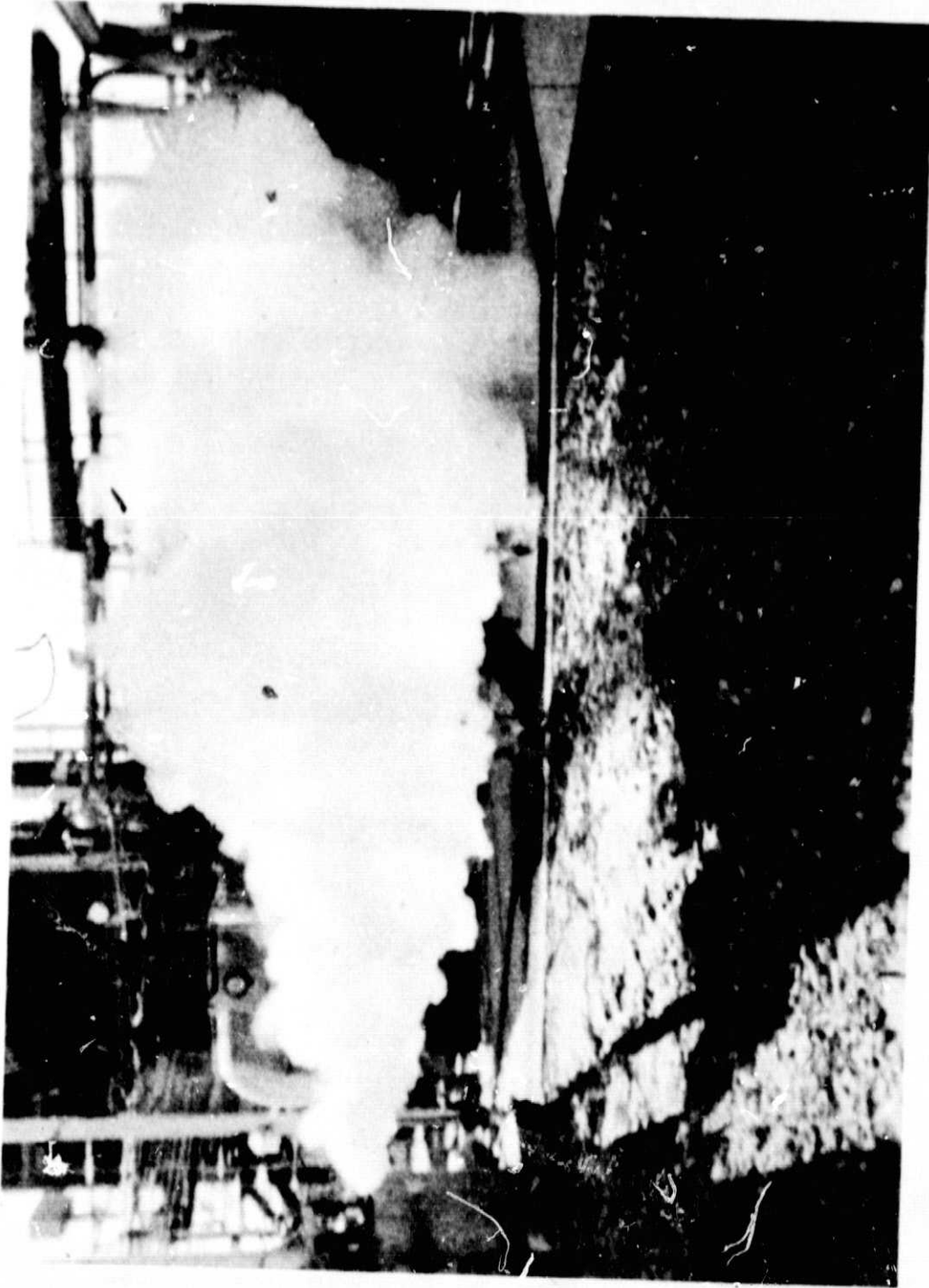

Figure 17. Aerosol Plume of Steam (From  $H_2O_2$  Catalytic Gas Generator) and Tetraethylene Glycol Mixture

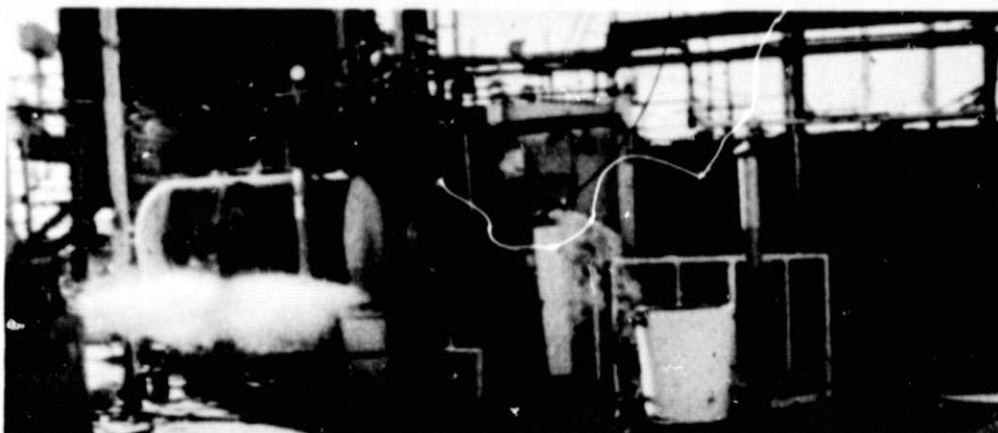

Figure 18a.

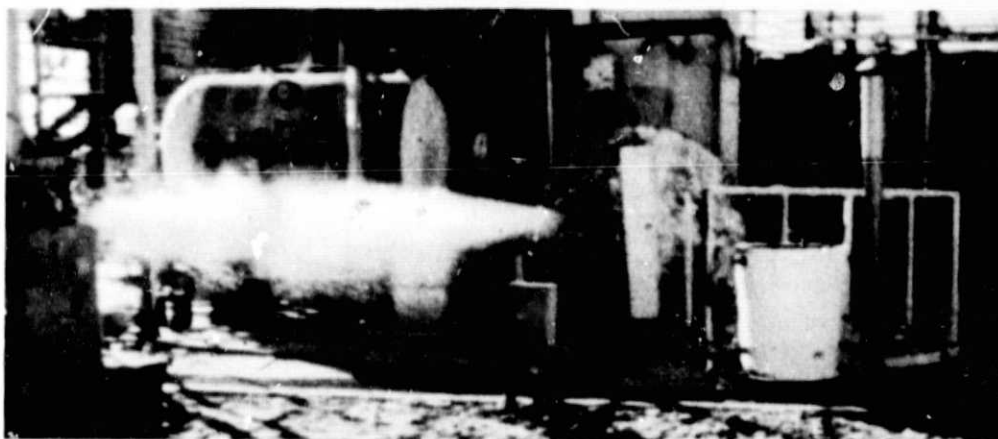

Figure 18b.

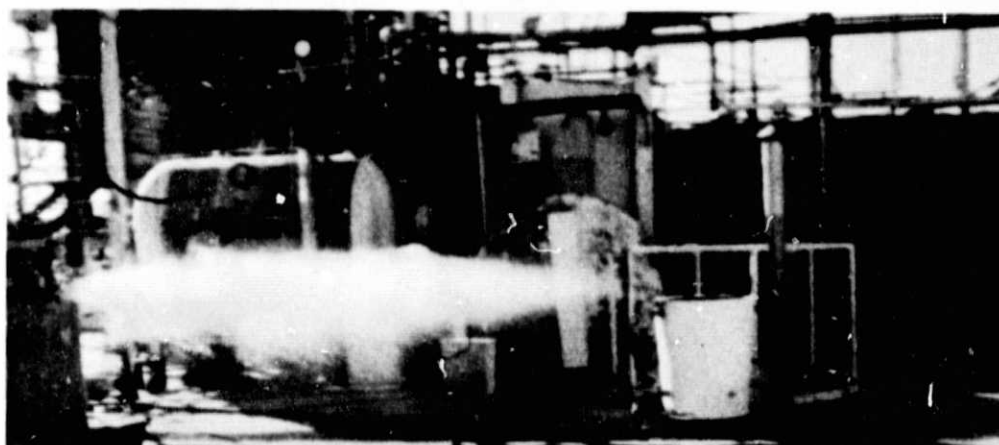

Figure 18c.

Figure 18. Unmixed  $H_2O_2$  - Steam Jet From  $H_2O_2$  Catalytic Gas  
Generator at  $t = .08, .12, \text{ and } .16 \text{ S}$

## V. Conclusions

The following summary of conclusions and inferences are drawn from the studies and experiments supported by this program.

1. The optical and transport properties, identified during early program studies as most desirable for maximum light scattering and persistency period of at least 300 s are as follows:
  - a. Particle diameter on order of 1 micron
  - b. Refractive index, 1.5
  - c. Vapor pressure  $1 \times 10^{-5}$  mm Hg
  - d. Molecular weight, near 200
2. A mass addition of approximately 2 to 6 lb/min for each droplet generator was analytically determined as adequate to mark vortices from aircraft of the 747 type. The test verification of this criterion should be the subject of future investigations.
3. Tetraethylene glycol was selected on the basis of desirable evaporation properties for use in development hardware for vortex marker devices.
4. Toxic hazards originating from exposures to tetraethylene glycol are non-existent, according to the manufacturers data. Results from limited material compatibility tests conducted at JPL gave indications of no gross reaction between tetraethylene glycol mists and painted (baked enamel) surfaces, e.g. automobile roof tops.
5. Commercially available spray/mist generators did not yield aerosol visibility and densities judged to be adequate for vortex marking. This led to specific designs for vaporizing/mixing devices, and to require the presence of heat (to vaporize the selected marker material) in order to produce suitable marker aerosols.

6. A small 25-lb<sub>f</sub> (nominal thrust) rocket chamber operated by catalytically decomposing H<sub>2</sub>O<sub>2</sub> to steam was a successful plume generator when used in conjunction with tetraethylene glycol.
7. The use of steam-glycol mixtures should be developed further for identification of vortices, wakes and "prop washes" generated by aircraft and helicopters. This development should include the following:
  - a. Optimization of H<sub>2</sub>O<sub>2</sub>-glycol mass ratios to achieve optimum aerosol persistency and visibility.
  - b. Design optimization of vaporizing/mixing components to achieve the required density, visibility and persistence of resultant sprays.
  - c. Expanded use of laser analytical instruments to clearly assist in quantifying spray particle characteristics.
8. The eventual application of vortex markers to night-time and inclement weather conditions should be defined and pursued.
9. The continued development of vortex marking aerosols should be pursued toward an early demonstration in actual flight tests.

## LIST OF REFERENCES

1. Bate, E.R. Jr., Aircraft Wake Modeling: Preliminary Design Aspects. Aerovironment Inc., Pasadena, California. Report AV FR 445, August 1974, JPL Contract 953964.
2. Back, L.H., Optical and Physical Requirements for Fluid Particles Marking Trailing Vortices from Aircraft. Journal of Aircraft Vol. 13, No. 7, July 1976, pp. 483-489.
3. Sarohia, V., Experimental Investigation of Sonicore Nozzle Flow for Liquid Atomization. JPL Internal Report 730-47, 30 July 1976.