

General Disclaimer

One or more of the Following Statements may affect this Document

- This document has been reproduced from the best copy furnished by the organizational source. It is being released in the interest of making available as much information as possible.
- This document may contain data, which exceeds the sheet parameters. It was furnished in this condition by the organizational source and is the best copy available.
- This document may contain tone-on-tone or color graphs, charts and/or pictures, which have been reproduced in black and white.
- This document is paginated as submitted by the original source.
- Portions of this document are not fully legible due to the historical nature of some of the material. However, it is the best reproduction available from the original submission.

McDonnell Douglas
955117 - Final
Volume 10

(NASA-CR-162375) PHASE 1 OF THE FIRST SMALL
POWER SYSTEM EXPERIMENT (ENGINEERING
EXPERIMENT NO. 1). VOLUME 4: COMMERCIAL
SYSTEM DEFINITION Final Report
(McDonnell-Douglas Astronautics Co.) 113 p G3/44

N79-33579

Unclas
38933

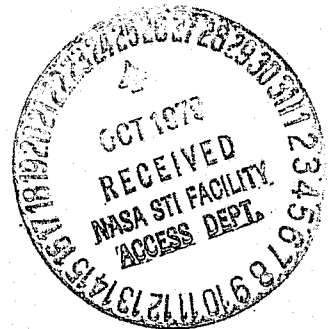

**PHASE I OF THE FIRST SMALL
POWER SYSTEM EXPERIMENT
(ENGINEERING EXPERIMENT NO. 1)**

**Final Technical Report
Volume IV – Commercial System Definition**

MCDONNELL DOUGLAS ASTRONAUTICS COMPANY

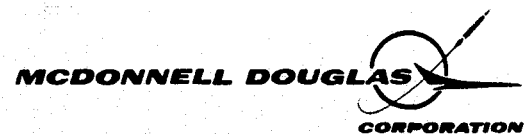

**PHASE I OF THE FIRST SMALL
POWER SYSTEM EXPERIMENT
(ENGINEERING EXPERIMENT NO. 1)**

**Final Technical Report
Volume IV – Commercial System Definition**



**PHASE I OF THE FIRST SMALL
POWER SYSTEM EXPERIMENT
(ENGINEERING EXPERIMENT NO. 1)**

**Final Technical Report
Volume IV – Commercial System Definition**

MAY 1979

MDC G7833

APPROVED BY: *R. J. Holl*
DR. R. J. HOLL
PROGRAM MANAGER

PREPARED FOR:
CALIFORNIA INSTITUTE OF TECHNOLOGY
JET PROPULSION LABORATORY
4800 OAK GROVE BLVD
PASADENA, CALIF. 91103
CONTRACT JPL NO. 955117
(NAS7-100, TASK ORDER NO. RD-152)

MCDONNELL DOUGLAS ASTRONAUTICS COMPANY-HUNTINGTON BEACH
5301 Bolsa Avenue Huntington Beach, California 92647 (714) 896-3311

PREFACE

This document constitutes the McDonnell Douglas Astronautics Company (MDAC) final technical report for Phase I of the First Small Power System Experiment (Engineering Experiment No. 1). Phase I is an investigation of various system concepts that will allow the selection of the most appropriate system or systems for the first small solar power system application. This 10-month study is a part of the Small Power Systems Program that is being developed under the direction of the Department of Energy (DOE) and managed by the Jet Propulsion Laboratory (JPL). The final report is submitted to JPL under Contract No. 955117.

The final technical report consists of five volumes, as follows:

- | | |
|----------|--|
| Volume I | Executive Summary |
| II | System Concept Selection |
| III | Experimental System Definitions
(3.5, 4.5, and 6.5 Year Programs) |
| IV | Commercial System Definition |
| V | Supporting Analyses and Trade Studies |

Requests for further information should be directed to the following:

- Mr. J. R. Womack, JPL Technical Manager
Jet Propulsion Laboratory
Pasadena, California
Telephone (213) 577-9302
- Dr. R. J. Holl, MDAC Program Manager
MDAC-Huntington Beach, California
Telephone (714) 896-2755
- Mr. R. P. Dawson, MDAC Deputy Program Manager
MDAC-Huntington Beach, California
Telephone (714) 896-3080
- Mr. W. H. Scott, Manager Energy Contracts
MDAC-Huntington Beach, California
Telephone (714) 896-4821

ACKNOWLEDGMENTS

The following personnel made significant contributions to this report:

MDAC

C. B. Boehmer	Reliability/Availability Analyses
W. L. Dreier	Energy Storage and Energy Transport Subsystems
C. R. Easton	Concentrator Assembly
T. Fahrner	Receiver Assembly
J. C. Grosse	Plant Control Subsystem
G. Hilliard	Maintainability and Logistics Analyses
G. L. Keller	Concentrator Assembly
R. H. McFee	Collector Field Optics and Receiver Flux
R. T. Neher	Receiver Assembly
J. H. Nourse	Costing Analyses
J. E. Raetz	Systems Analysis
E. J. Riel	Plant Control Subsystem
E. T. Suter	Energy Transport Subsystem
B. E. Tilton	Systems Analysis and Power Conversion Subsystem

Rocketdyne

R. R. Gross	Receiver Assembly Design
D. E. Vanevenhoven	Collection Fluid Analysis
J. J. Vrolyk*	Receiver Assembly, Energy Storage Subsystem

Stearns-Roger

J. Dubberly	Tower Assembly: Power Plant Equipment
J. Gormely	Tower Assembly; Power Plant Equipment
W. R. Lang*	Tower Assembly; Power Plant Equipment

Energy Technology, Inc.

T. T. Kolenc*	Radial Outflow Turbine
---------------	------------------------

University of Houston Energy Laboratory

Dr. R. C. Bannerot*	Heliostat Field Analysis
Dr. L. L. Vant-Hull	Heliostat Field Analysis

*Subcontractor Program Manager

CONTENTS

Section 1	PHASE I PROGRAM INTRODUCTION	1-1
	1.1 Study Task Approach	1-3
	1.2 Roles and Responsibilities	1-4
	1.3 System Summary	1-5
	1.4 Commercial System Definition	1-5
Section 2	SUMMARY	2-1
Section 3	COMMERCIAL SYSTEM DEFINITION	3-1
	3.1 System Design and Performance Summary	3-1
	3.1.1 Collector Subsystem - Concentrator Assembly	3-5
	3.1.2 Collector Subsystem - Receiver Assembly	3-7
	3.1.3 Collector Subsystem - Tower Assembly	3-8
	3.1.4 Energy Storage Subsystem	3-12
	3.1.5 Energy Transport Subsystem	3-14
	3.1.6 Power Conversion Subsystem	3-18
	3.1.7 Plant Control Subsystem	3-26
	3.2 Operational Characteristics	3-29
	3.3 Fabrication and Installation Characteristics	3-31
	3.3.1 Fabrication of Subsystem Elements	3-31
	3.3.2 Installation Flow Concepts	3-32
	3.4 Maintenance and Repair Characteristics	3-32
	3.4.1 Scheduled Maintenance	3-34
	3.4.2 Corrective Maintenance	3-42
	3.5 System Safety Characteristics	3-43
	3.6 Utility and Community Interfaces	3-45
	3.7 Stand-Alone Capability	3-46
	3.8 Handling and Transportation	3-48
	3.8.1 Sizing and Weight Limitations	3-48
	3.8.2 Shock and Vibration Limitations	3-48
	3.9 Installation and Checkout	3-48
	3.9.1 Installation	3-48
	3.9.2 Alignment and Checkout Concepts	3-51
	3.10 Cost Summary	3-54
	3.10.1 Costs	3-54
	3.10.2 Ground Rules and Assumptions	3-54

	3.10.3 Costing Approach	3-56
	3.10.4 Heliostat Costing Methodology	3-60
Section 4	SENSITIVITY TO RATED POWER CHANGES	4-1
	4.1 Design and Performance Impact	4-1
	4.1.1 Collector Subsystem - Concentrator Assembly	4-1
	4.1.2 Collector Subsystem - Receiver Assembly	4-12
	4.1.3 Collector Subsystem - Tower Assembly	4-16
	4.1.4 Energy Transport Subsystem	4-18
	4.1.5 Energy Storage Subsystem	4-18
	4.1.6 Power Conversion Subsystem	4-18
	4.1.7 Plant Control Subsystem	4-18
	4.2 Cost Impact of Power Rating Variations	4-23
Section 5	SENSITIVITY TO CAPACITY FACTOR CHANGES	5-1
	5.1 Design and Performance Impact	5-1
	5.1.1 Collector Subsystem - Concentrator Assembly	5-1
	5.1.2 Concentrator Field Optimization - No Storage Case	5-2
	5.2 Cost Impact of Capacity Factor Variations	5-9

Section 1
PHASE I PROGRAM INTRODUCTION

The Solar Thermal Power Systems Office of the Division of Solar Energy of DOE has initiated several application-oriented programs, one of which is the Small Power Systems Program. The overall objective of this program is to develop and foster the commercialization of modular solar thermal power systems for application in the 1 to 10 MWe range. Potential applications include power systems for remote utility applications, small communities, rural areas, and industrial users. Engineering Experiment No. 1 represents the first small power system to be developed under this program.

The primary goal of Engineering Experiment No. 1 (EE No. 1) is to identify suitable technological approaches for small power systems applications and to design, fabricate, field install, test and evaluate a solar power facility based on an optimum use of near-term technologies. Investigation of the performance, functional, operational and institutional interface aspects of such a facility in a field test environment are additional objectives.

Engineering Experiment No. 1 will be conducted in three phases: Phase I - Concept Definition, Phase II - Design and Development Testing, and Phase III - Plant Construction and Testing. Three candidate programs for EE No. 1 are shown on Figure 1-1.

Phase I objectives were to investigate various system concepts and develop information which will allow selection of the most appropriate system for the first small power system application. System design and system optimization studies were conducted considering plant size, annual capacity factor, and startup time (the time from start of Phase I to the initiation of testing in Phase III) as variables. The primary output of Phase I was to be the definition of preferred system concepts for each startup time, design sensitivity and cost data for the systems studied, and Phase II Program Plans for each preferred system concept.

- THREE CANDIDATE PROGRAMS FOR EE NO. 1

PROGRAM STARTUP TIME	YEARS FROM PHASE I START										
	1	2	3	4	5	6	7	8	9	10	
	CY78	79	80	81	82	83	84	85	86	87	88
3.5 YEAR				ON-LINE							
	P-I (10 MO)	P-II (8 MO)	P-III (22 MO)	TEST (12 MO)							
4.5 YEAR				ON-LINE							
	P-I (10 MO)	P-II (18 MO)	P-III (24 MO)	TEST (12 MO)							
6.5 YEAR							ON-LINE				
	P-I (10 MO)	P-II (42 MO)	P-III (24 MO)	TEST (12 MO)							
COMMERCIAL OBJECTIVE											

- THREE PROJECT PHASES
 - I CONCEPT DEFINITION
 - II PRELIMINARY AND DETAILED DESIGN;
COMPONENT/SUBSYSTEM DEVELOPMENT/TESTING
 - III FABRICATION, INSTALLATION, TEST AND EVALUATION
- CATEGORY A CANDIDATE SYSTEMS - GENERAL, EXCLUDING DISH CONCENTRATORS

Figure 1-1. Overall Program Scope

Phase II involves the preliminary and detailed design of the preferred system, and component and/or subsystem development testing that are needed before proceeding with plant construction in Phase III. Phase II may be from 8 to 42 months depending on the program selected by JPL as a result of Phase I.

Phase III will consist of subsystem fabrication, plant construction, installation, testing, and evaluation of the solar power facility (Engineering Experiment No. 1). A 3-year schedule is anticipated for this phase, with testing conducted during the third year.

Late in the Phase I study period, DOE concluded that a better balance of the overall solar thermal electric program could be achieved by limiting the JPL Small Power Applications activities to point-focus distributed systems. Consequently, DOE directed that JPL take the necessary steps to constrain the JPL-managed first Engineering Experiment (EE No. 1) to point-focusing distributed receiver technology for all phases beyond Phase I. Accordingly, on 3 April 1979, all MDAC efforts on Phase II program planning were terminated by JPL directive.

1.1 STUDY TASK APPROACH

Phase I study objectives were: (1) select preferred system concepts for each of the three program durations, (2) complete conceptual designs for each of three system concepts, (3) provide sensitivity data over range; plant rating: 0.5-10 MWe; annual capacity factor: 0 storage to 0.7, (4) prepare detailed Phase II plans and cost proposal (3 versions of EE No. 1), (5) prepare Phase III program and cost estimates (3 versions of EE No. 1), and (6) recommend preferred EE No. 1 program. Three major tasks were planned for the 10-month Phase I effort. They were Task 1 - Development of Preferred System Concepts, Task 2 - Sensitivity Analyses, and Task 3 - Phase II Program Plans. The Top-Level study flow is indicated in Figure 1-2.

In Task I, three preferred concepts were defined to the conceptual design level. The concepts were consistent with the three specified program startup

9CR20

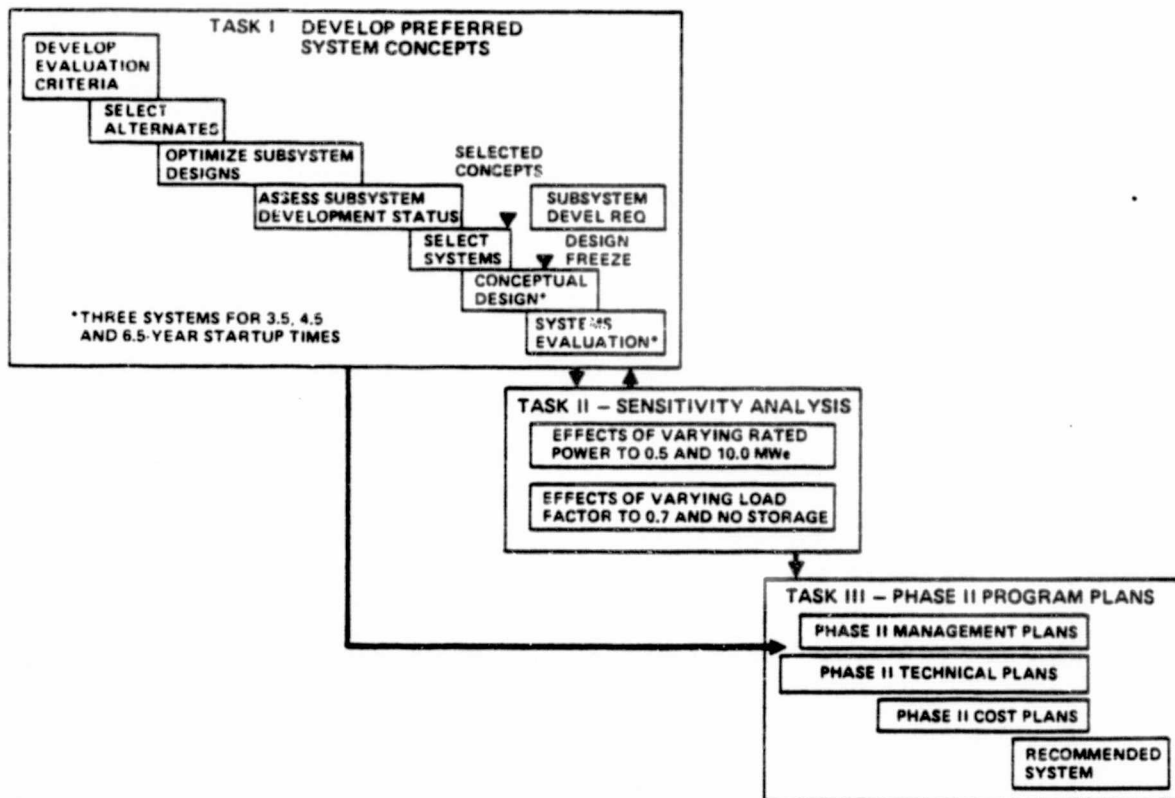

Figure 1-2. Top Level Study Flow

times of 3.5, 4.5, and 6.5 years. In Task I, power plants were considered for a nominal 1.0 MWe rated capacity and 0.4 capacity factor. Activities in Task I through the selection of the three preferred system concepts were primarily a systems engineering/evaluation conducted by MDAC. Subsystem characteristics, performance, and preliminary development requirements were supplied by the appropriate subcontractors. Following this concept selection, the conceptual design of subsystems was initiated in which descriptions, finalized development requirements, performance, reliability, and cost data for each of the three selected concepts were developed.

In Task II, the impact of varying rated power (0.5 and 10.0 MWe) and system capacity factor (zero storage case and 0.7) was investigated. Sensitivity analysis in Task II was performed by MDAC using subsystem data supplied by the subcontractors. This task featured system and subsystem reoptimization for each of the cases evaluated.

In Task III, the management, technical and cost plans for Phase II for each of the three selected concepts were to be prepared in accordance with JPL guidelines and MDAC system recommendations were to be provided. However, as reviewed above, during the latter period of the contract, JPL directed MDAC to terminate all Task III efforts. Accordingly, Task III efforts were discontinued and Phase II Program Plans are not reported.

1.2 ROLES AND RESPONSIBILITIES

A team of companies led by the McDonnell Douglas Astronautics Company (MDAC) was contracted to conduct the Phase I definition of Category A systems (general only excluding dish concentrators). The team includes MDAC, Rocketdyne, Stearns-Roger, the University of Houston Energy Laboratory, and Energy Technology, Incorporated (ETI). MDAC was the prime contractor for the effort and was responsible for overall contract compliance. The four major subcontractors and their prime areas of responsibility were: (1) Rocketdyne Division of Rockwell International (receiver, dual-media energy storage),

(2) Energy Technology, Inc. (radial turbine and gearbox), (3) Stearns-Roger (tower and plant layout/equipment), and (4) University of Houston Solar Energy Laboratory (collector field optimization).

1.3 SYSTEM SUMMARY

From the preliminary design analyses efforts to date, MDAC concludes that the proposed central receiver power system concept is a feasible, low-cost, and low-risk approach for a small solar power system experiment. It is particularly suitable for early deployment under the 3.5- and 4.5-year programs. The concentrator subsystem is currently under development and low-cost, high-production rate heliostats will be available for this program. The proposed receiver subsystem using Hitec is similar to existing fossil fired/Hitec heaters. The tower is a standard low-cost guyed steel tower. The energy transport system using Hitec is based on standard state-of-the art equipment and operating conditions. For the 3.5- and 4.5-year programs, a simple two-tank storage subsystem is proposed which requires no development. The power conversion system is based on existing axial steam turbines. All the balance of plant equipment involves state-of-the-art equipment and processes. The 6.5-year program contains development of a radial outflow turbine and qualification of a dual media thermocline storage subsystem. The technology employed in all programs is consistent with the development time available. Thus, the proposed MDAC concepts satisfy all of the important JPL selection criteria, namely, high operational reliability, minimum risk of failure, good commercialization potential, and low program costs.

1.4 COMMERCIAL SYSTEM DEFINITION

This volume contains the preliminary description of the commercial system that would evolve from the experimental programs. Section 2 presents a brief summary and MDAC recommendations. Section 3 contains the definition of the system and preliminary cost data. The sensitivity of the basic design to changes in rated power and capacity factor are given in Section 4 and 5, respectively.

Section 2 SUMMARY

From the preliminary design analyses efforts to date, MDAC concludes that the proposed commercial version of the central receiver power system is a feasible, low-cost and low-risk approach for a small solar power system. The commercial system is described in Section 3 and is nearly identical to the 6.5-year experimental system described in Volume III.

The sensitivity of the plant to changes in power rating and capacity factor was also investigated. The power rating was varied from 0.5 to 10.0 MWe at constant capacity factor of 0.4. Likewise, the capacity factor was varied from no storage to 0.7 at constant rated power of 1.0 MWe. Specific trade studies and analyses performed are presented in Sections 4 and 5. For the 10 MWe power rating, both a cavity-cone receiver with a north field, and a cylindrical receiver with a 360° field were investigated. From the results of trade studies, the north field/partial cavity receiver was selected for the 10 MWe power rating because of (1) a more effective field performance, (2) a higher receiver efficiency, and (3) a lower overall figure of merit (\$/GWh/yr). More specific design and trade study results for power rating changes are given in Section 4 of this volume.

For the no-storage case, a small two-tank energy storage system was retained to isolate the power conversion subsystem from insolation transients caused by intermittent cloud passage. These buffer tanks were sized for 10 minutes of full-load operation. The corresponding heliostat field was optimized to produce 1 MWe at 750 watts/m². Consequently, the "no-storage" case has a capacity factor of 0.275. This optimization is discussed in detail in Section 5.

Sensitivity study design results are summarized on Table 2-1. The first column represents the "no-storage" design case, whereas the second column is the nominal system design (1.0 MWe, 0.4 capacity factor). As noted, for the "no-storage" case, major design changes are a decrease in the thermal storage capacity (from 10.9 to 0.5 MWht), the number of heliostats (from 133 to 110), and overall system efficiency (derated for off-design performance). For the 0.7 capacity factor (third column of Table 2-1), a larger dual-media thermal storage tank is utilized, the number of heliostats increased (from 133 to 227), the receiver aperture slightly increased (from 3.5 to 4.5 m) and the tower height slightly increased (from 36 to 40 m).

For the 0.5 MWe rated power case, the same receiver and tower are utilized, but the number of heliostats are significantly reduced (from 133 to 76), and thermal storage capacity slightly reduced. For the 10 MWe rated power case, the number of heliostats increase from 133 to 1,312, the receiver aperture diameter increased from 3.5 to 8.0 m, the tower height increased from 36 to 90 m and the storage thermal capacity increased from 10.9 to 105.3 MWht.

Table 2-1. Sensitivity Study Results

Net Power Output, MWe	1.0	1.0	1.0	0.5	10.0
Capacity Factor	0.275	0.4	0.70	0.4	0.4
Turbine Expansion Efficiency	0.84	0.84	0.84	0.79	0.85
Cycle Efficiency	0.370*	0.388	0.388	0.365	0.394
Thermal Storage Technique	10 min Buffer Only	Thermo- cline	Thermo- cline	Thermo- cline	Thermo- cline
Thermal Storage Capacity, MWht	0.5	10.9	36.6	7.4	105.3
Receiver Power, MWt	2.93	4.72	8.01	2.68	44.8
Receiver Aperture Diameter, m	3.5	3.5	4.5	3.5	8.0
Tower Height, m	36	36	40	36	90
Number of Heliostats	110	133	227	76	1,312

*Derated for off-design performance

Energy costs for each of these variations relative to the nominal plant were also compared. The costs were calculated using the method defined in The Cost of Energy Utility Owned Solar Electric System, JPL 5040-29; ERDA/JPL-1012-76/3, June 1976. The results are shown on Figure 2-1. The lower curves represent relative capital costs and the upper curves represent total energy costs (capital plus operations and maintenance costs). All costs are shown relative to the nominal commercial plant (1.0 MWe, 0.4 capacity factor). As indicated on the figure, as plant rating decreases to 0.5 MWe, relative energy costs increase sharply. As the plant rating increases, relative energy costs more gradually decrease to about 0.7 of nominal at 10 MWe. As plant capacity factor increases, the relative energy costs decrease gradually to about 0.75 at a capacity factor of 0.7. It may be concluded from this sensitivity analyses that a more cost-effective design would be to increase both the plant power rating and a capacity factor for small power systems.

More specific design and analyses information are contained in the remaining sections of this report.

CR20-IV

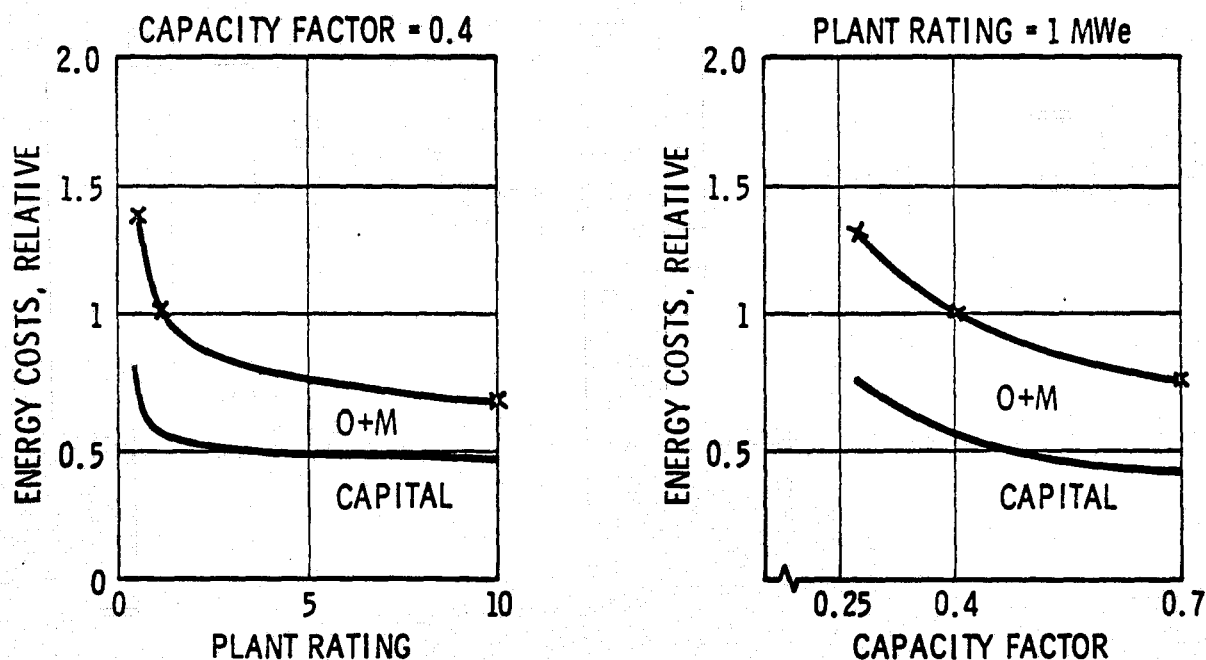

Figure 2-1. Sensitivity Results

Section 3
COMMERCIAL SYSTEM DEFINITION

The commercial system design has been developed to meet the same set of general characteristics used to develop the experimental systems. These top level characteristics are reiterated below.

System Electrical Output	1 MWe (net)
System Capacity Factor	0.4
System Availability	>0.95
Insolation Model	Barstow 1976

3.1 SYSTEM DESIGN AND PERFORMANCE SUMMARY

The system can be divided into five principal subsystems. The collector subsystem consists of the concentrator assembly, receiver assembly, and tower assembly. The concentrator assembly includes the heliostats, wiring and field controls. The receiver assembly consists of the absorber, insulation, enclosure and instrumentation. The receiver is supported by the tower assembly which also provides receiver maintenance facilities and supports the piping to and from the receiver. The energy transport subsystem includes all of the HTS piping and flow control equipment. The energy storage subsystem includes the thermocline storage tank and instrumentation. The power conversion subsystem consists of all water/steam loop components required for use with a radial outflow turbine. This subsystem also provides the electrical distribution to grid and plant and includes all water treatment equipment. The plant control subsystem provides for both individual subsystem operations and integration of these operations.

The system is designed so that operation of the power conversion subsystem is decoupled from the operation of the collector subsystem. This is accomplished by the use of two separate energy transport loops; one extracting energy from

the receiver and depositing it in the storage subsystem and the other extracting energy from the storage subsystem and supplying it to the power conversion system. A general system schematic is shown in Figure 3-1.

The performance of the system was analyzed by treating each of the subsystems separately and then combining the performances into an integrated system performance. The results of the performance analysis are presented graphically in the form of an energy "waterfall" chart in Figure 3-2. The sizing of the concentrator field was accomplished by starting at the net electrical energy required per year and working "backward", adding the various energy losses and inefficiencies until a figure representing the required total direct insolation per year is obtained.

The performance of the concentrator assembly was analyzed by the University of Houston as part of the concentrator field optimization. This analysis was based on an annual insolation model that is nearly identical to measured Barstow insolation. The field performance parameters generated by the University of Houston were then input to the MDAC Program P5595, along with Barstow insolation, wind velocity, and ambient temperature data. The performance of the field was computed at 15-min intervals for an entire year to obtain a more accurate estimate of the annual energy collection. The electrical energy produced by the system each month based on the Barstow insolation data is presented in Figure 3-3.

The performance analysis of the energy transport loop was based on steady state losses at normal operating temperatures and transient losses during periods of no insolation for typical duty cycles. Electrical trace heating energy requirements were also analyzed for the typical duty cycle. The thermal losses of the energy storage subsystem are also based on a typical duty cycle accounting for steady state thermal losses when storage is full and transient losses when storage is empty. Thermal losses of the power conversion subsystem during normal operation, startup/cleanup, and nighttime cooldown were also computed based on a typical duty cycle.

3-3

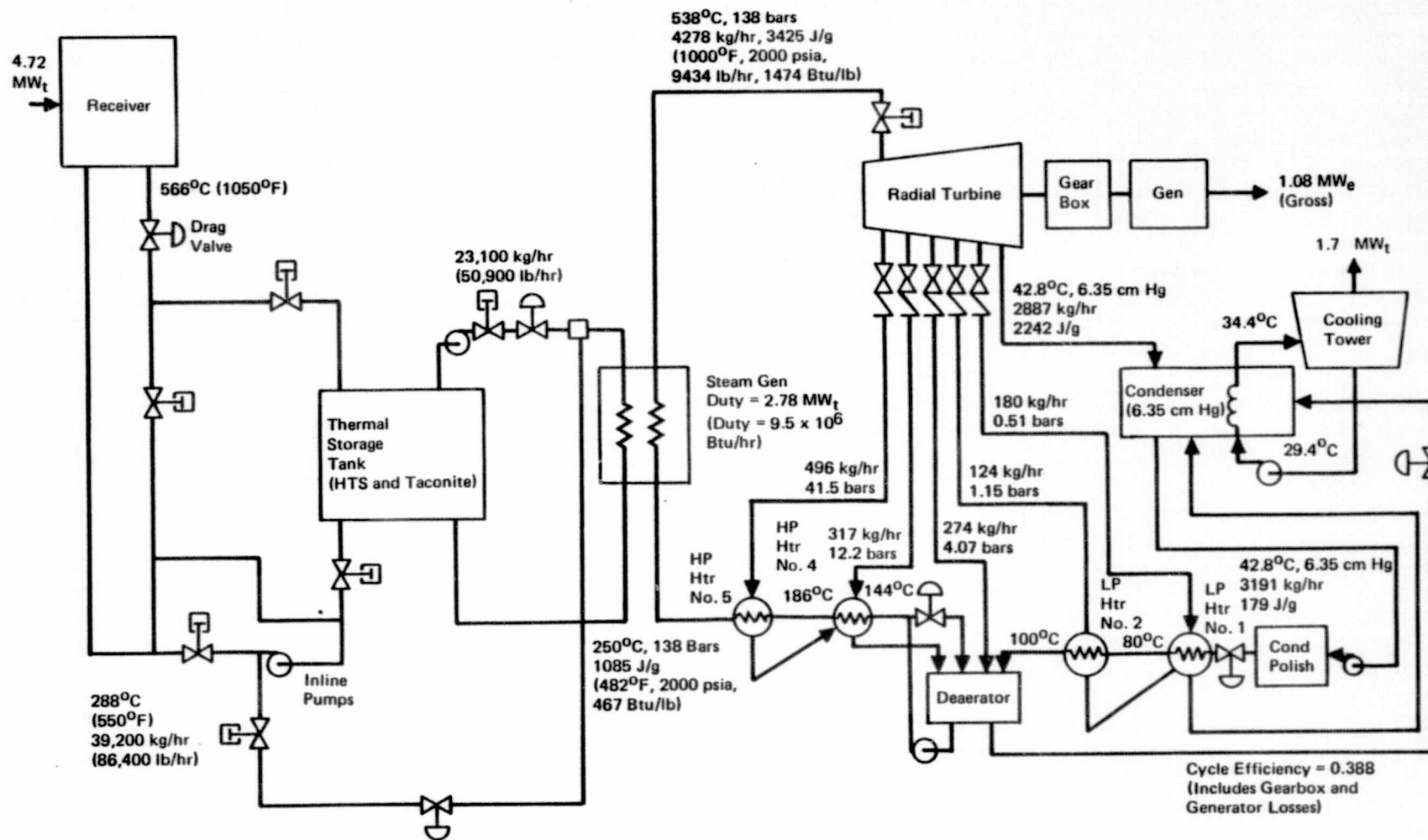

Figure 3-1. System Schematic (Commercial System)

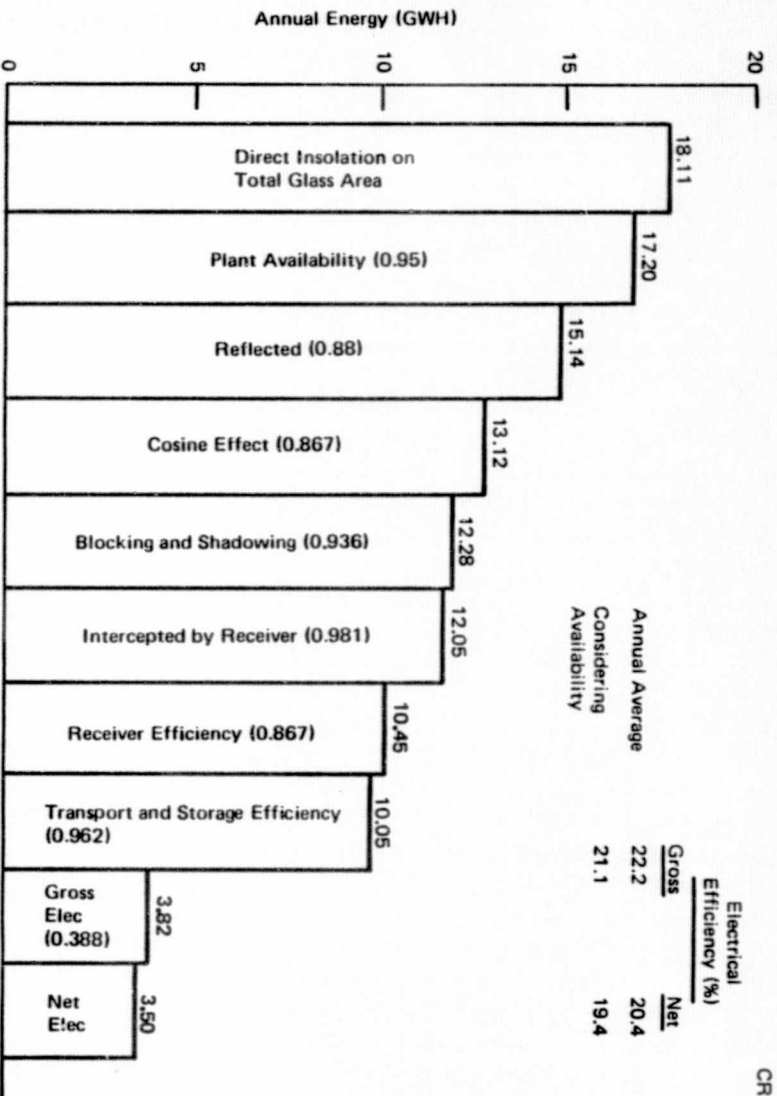
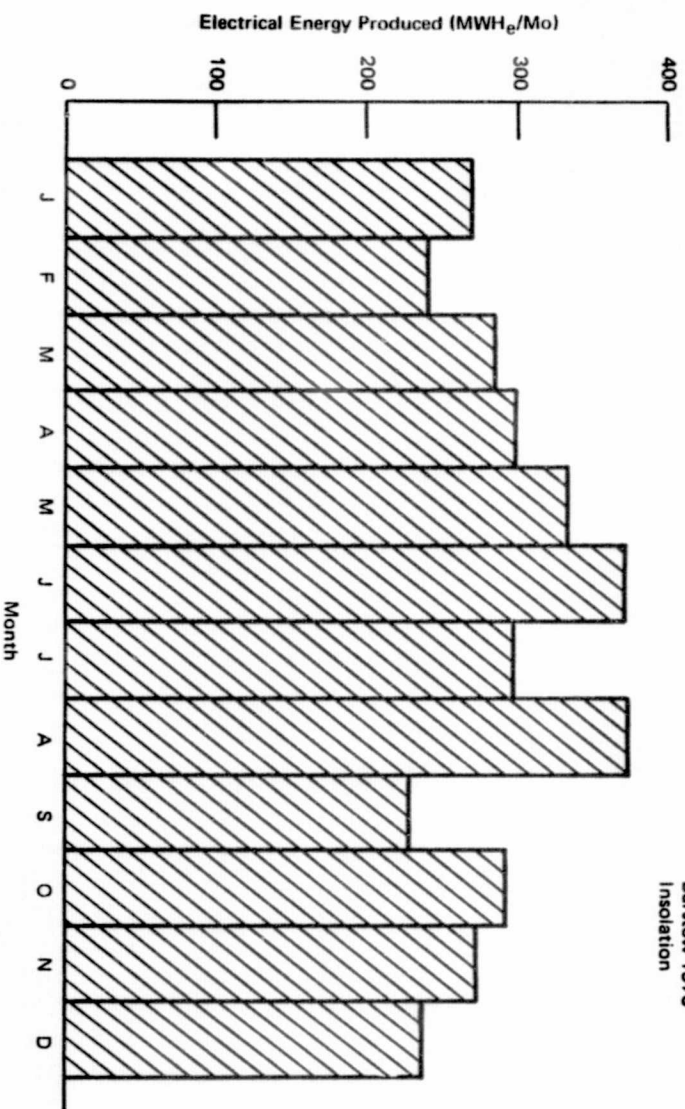

Figure 3-2. Performance Waterfall for Commercial System

CR20-1V



Based on Barrow 1976 Insolation

Figure 3-3. Monthly Energy Production

3-4

Parasitic power consumption of the auxiliary equipment was calculated based on the duty cycles used for each subsystem. The gross electrical power capability of the turbine-generator, the emergency diesel generator requirements and the uninterruptable power supply requirements were then obtained from these results, in addition to the annual parasitic energy required.

3.1.1 Collector Subsystem - Concentrator Assembly

The function of the concentrator assembly is to collect, redirect, and focus solar insolation on a receiver aperture that is centrally mounted on a tower. The concentrator assembly consists of a north field of heliostats plus related controls and necessary electrical power supply for drive purposes. The heliostats are individually mounted on pedestals and are segmented for each site assembly. Each heliostat has four subassemblies: the reflector panels, the drive unit, the pedestal support and foundation, and the control subassembly. This heliostat is identical to the one used in the 4.5-year and 6.5-year programs as shown in Figure 3-4 and discussed in detail in Volume III, Section 4.

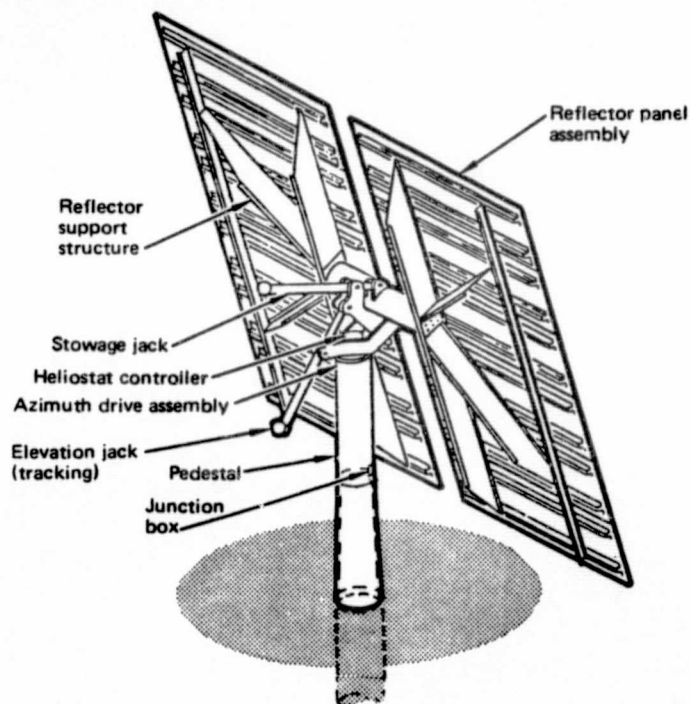

Figure 3-4. Second Generation Heliostat

There are two reflector panels per heliostat and each panel is made up of six mirror modules. The mirror modules use second-surface glass mirrors. The modules are attached to a support structure that maintains their alignment and rigidly attaches them to the drive unit. Focusing is achieved by slightly curving the mirror modules during manufacturing, and by shimming the modules to the proper cant angles after attachment to the support structure.

The drive unit incorporates an azimuth and elevation drive mechanism. It is mounted on top of the pedestal and consists of motors, drive transmissions, position feedback sensors, reflector support bearings, and a structural housing. The drive unit positions the reflector during normal operation to redirect the solar beam radiation to the receiver aperture. The drive unit can also position the heliostat in an inverted stowage position to minimize the risk of damage from severe weather conditions.

The pedestal support and foundation is used to mount the heliostat in the field. A central support steel pedestal concept is used. The drive unit and reflector panels are mounted on top of the pedestal. The pedestal is rigidly attached to a precast concrete foundation by a slip joint.

Heliostat control is achieved from the control subassembly. Field controllers calculate the sun's position, direct individual heliostat motions, calculate any errors in position, and redirect corrective motions. Heliostat controllers calculate actual heliostat position, compare to the commanded position from the field controller, and drive the motors to correct the errors indicated. Power supply to the drive units and the control function are made through a "serial hook-up". This enables remaining heliostats to function normally should one heliostat fail. All heliostat controls have manual override capabilities.

The individual heliostat availability is 0.99987, and the probability that at least 98% of the field will be available is essentially unity. The heliostats meet all the design requirements specified by the Department of Energy. Performance requirements concerning survival in high winds, high temperatures, precipitation and seismic disturbances have all been met or exceeded.

The collector system in the commercial program employs the prototype or second generation heliostat with a reflector area of 49 m². The 133 heliostats will be placed in a north field of approximately 6 acres as determined by optimization programs.

3.1.2 Collector Subsystem - Receiver Assembly

A preliminary design sketch of the receiver, assembled at the top of the tower, is shown in Figure 3-5. The receiver consists of six subassemblies:

- A. Absorber Unit
- B. Absorber Support Structure
- C. Piping, Instrumentation and Supports
- D. Insulation
- E. Heaters
- F. Absorber Doors

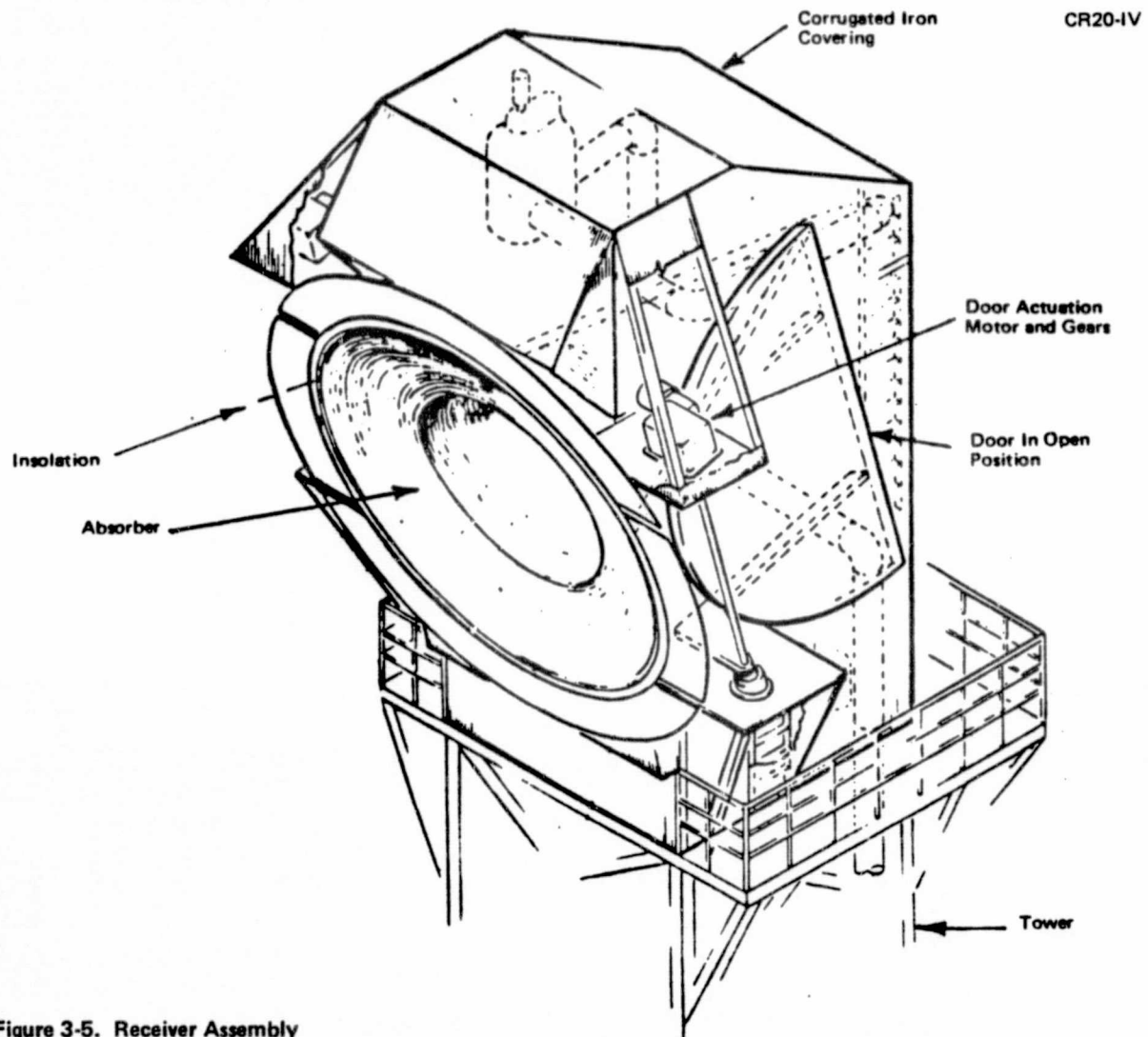

Figure 3-5. Receiver Assembly

The absorber is constructed of thin wall seamless tubing, 3.81 cm (1.5 in) outside diameter and of 0.241 cm (0.095 in) wall thickness. Three of these tubes in parallel are wound spirally, first in the form of a shallow cone, starting at the largest diameter and working inwardly and toward the apex. At about the half-way point, the angle at the cone apex is changed from that of a shallow cone (150°) to a deep cone (33.4°). The three parallel tubes then spiral inward, forming the surface of a steep cone, to within about 60 cm (2 ft) of the cone apex at which point they are terminated at a conical collecting manifold which serves not only to combine the three parallel paths into a single outlet at the apex, but to provide adequate heat absorption and cooling near the apex. The base of the shallow cone is 3.5 m (11.5 ft) in diameter and the apex is 4.0 m (11.5 ft) above the lowest point of the base. The three parallel tubes start at points spaced 120° apart around the outer edge of the base and terminate at the apex manifold at points 120° apart. Thus each of the three tubes has a nearly identical path length and geometrical shape. A distribution manifold, designed to ensure an equal flowrate of coolant into each of the three parallel tubes, is provided ahead of the outer rim. Separate throttling valves and flow meters for each of the three tubes are not used in order to produce a simpler, more reliable system.

The remainder of the receiver assembly, including the absorber support structure, piping and instrumentation, insulation, heaters and doors are identical to that of the experiment plant receiver described in Volume III, Section 4. A summary of the characteristics of the commercial receiver is presented in Table 3-1.

3.1.3 Collector Subsystem - Tower Assembly

A preliminary description of the tower and the necessary ancillary equipment for the commercial system is given in this section. The tower is a guyed-steel structure which is designed to support the weight of the receiver and ancillary equipment and is capable of surviving wind and seismically induced overturning moments as summarized in Volume III, Appendix A. The principal elements of the tower include:

- Structure
- Guy Wires

Table 3-1. Commercial Receiver Characteristics

Peak Power, MWt absorbed	4.72
Fluid	
Type	HTS
Weight Flow Rate, kg/hr (lb/hr)	39100 (86,000)
Volume Flow Rate at 427°C (800°F), liter/sec (gal/min)	5.96 (94.5)
Inlet Temperature, °C (°F)	288 (550)
Outlet Temperature, °C (°F)	566 (1050)
Pressure Drop, bars (lb/in ²)	5.6 (81)
Pumping Power, kW hyd	3.3
Maximum Velocity m/sec (ft/sec)	2.51 (8.24)
Absorber	
Aperture, Diameter, m (ft)	3.5 (11.5)
Cavity Depth, m (ft)	4.0 (13.1)
Peak Heat Flux kW/m ² (Btu/hr ft ²)	401 (127,000)
Weight, kg (lb)	1153 (2536)
Tubing	
Outside Diameter, cm (in)	3.81 (1.5)
Wall Thickness, cm (in)	0.241 (.095)
Material	INCO-800
Number of Parallel Paths	3

- Foundation.
- Work platforms.
- Pipe supports.
- Access ladder and service elevator.
- Plant services (water GN₂, electric power, pneumatic lines, lightning, lightning protection, etc.).
- Instrumentation.

The preliminary tower design is shown in Figure 3-6.

The tower structure is 36 m (118 ft) high and is constructed of structural steel angles (15 x 15 cm). The vertical members are located on a square pattern 3.05 m on a side and serve as the four attachment points for the receiver.

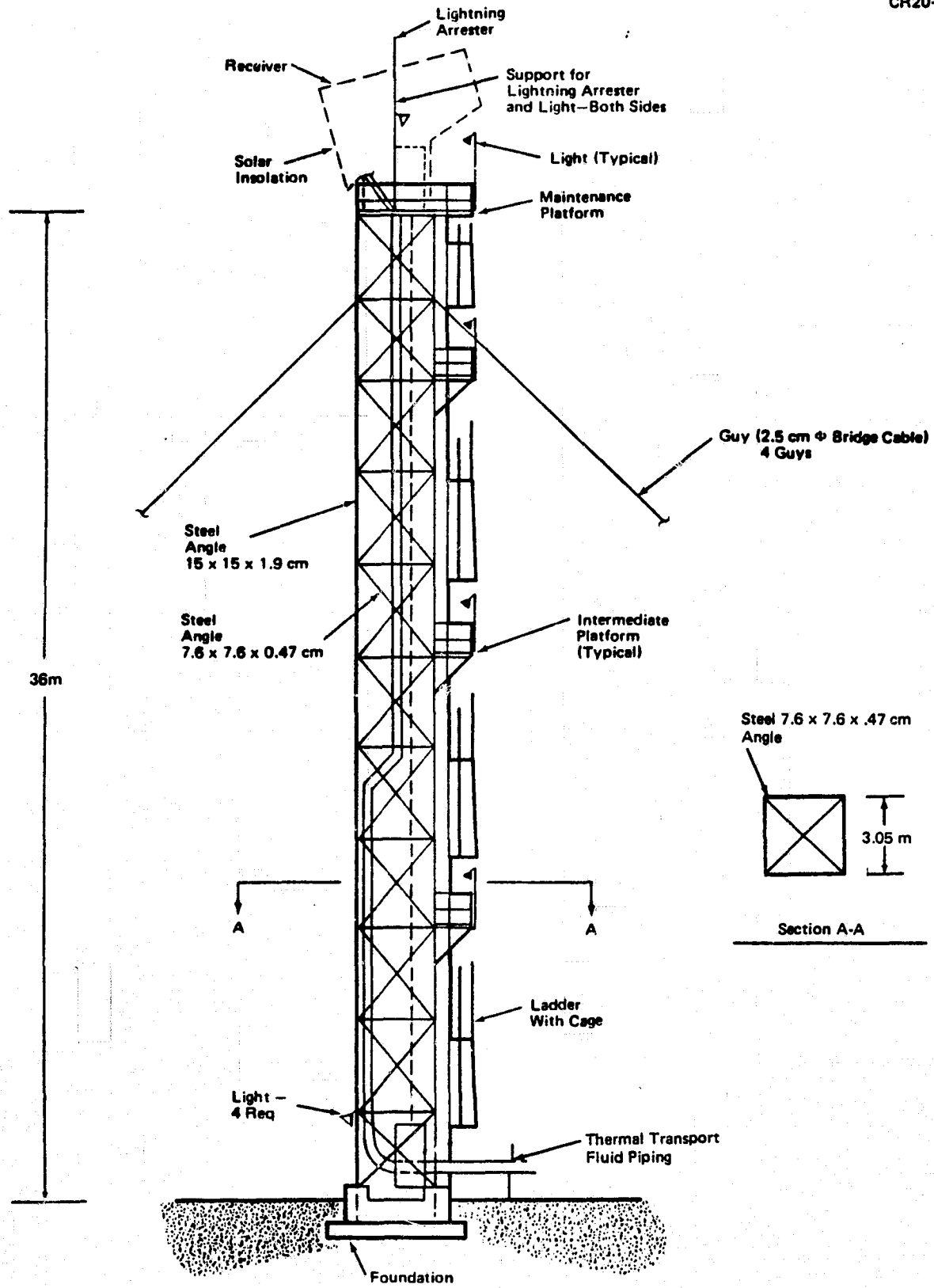

Figure 3-6. Tower

The tower contains 11,800 kg of structural steel (A36). Special provisions are included for the attachment of pipes and cables and the caged ladder. The structural steel is painted to prevent corrosion.

The guy wires extend in a diagonal direction outward from the tower and are at a 45° angle relative to vertical. The guys are made of galvanized bridge cable (2.54 cm diameter) and are attached to the tower one tower-section below the receiver. They are tensioned to allow less than a 15 cm receiver deflection at a reference wind speed of 16.1 m/s (at 10 m vertical elevation).

The tower foundation is of a mat design made up of reinforced concrete. The mat is square (6.1 x 6.1 m) and 0.61 m thick. The mat contains 28 m³ of concrete. Each dead man anchor for the guy wires is a 1.5 x 1.5 x 2.1 m concrete block which is buried 1.5 m below grade.

A work platform will be located at the top of the tower. It utilizes steel gratings and standard railings per OSHA standards. Access to the platform is by the caged ladder. Safety gates surround the access openings. At points along the caged ladder route, intermediate platforms are located which can serve both as rest and local work areas. These platforms are also made of steel gradings and utilizes standard safety railings.
railings.

The pipes are restrained and supported by standard counterweight pipe supports which allow the pipes to expand downward from the receiver interface plant at the 36 m elevation. The maximum vertical pipe travel at the bottom of the tower is 22.7 cm which will be accommodated by the pipe support. Sufficient clearance will be maintained between the final bend and the ground or ground-mounted structures to allow for this pipe growth.

The access ladder will provide access from the ground to the tower top work platform. The design will be developed in accordance with OSHA requirements and will include the necessary intermediate rest platforms.

Plant service lines will be routed up the tower to provide water, GN₂, electric power, and compressed air to the tower top work platform as well as any of the intermediate work levels on an as required basis. The electrical

power lines will also service trace heaters and the tower lights. In addition, a high-intensity white light will be mounted at the highest point of the receiver-tower structure along with aircraft warning lights in compliance with FAA regulations. Lightning arresters will be located to protect the highest portion of the receiver-tower structure while provisions will be included in the tower design to accommodate the arrester grounding cable.

Instrumentation lines required for the operation, control, and/or monitoring of the receiver and riser/downcomer will be mounted to the tower. The location of these wires and the shielding and protection will be selected to isolate these lines from both environmental and electromagnetic interference.

3.1.4 Energy Storage Subsystem

The energy storage subsystem, shown in Figure 3-7, consists of the following components:

- Storage tank and media
- Insulation
- Immersion Heater
- Gaseous nitrogen supply

CR20-IV

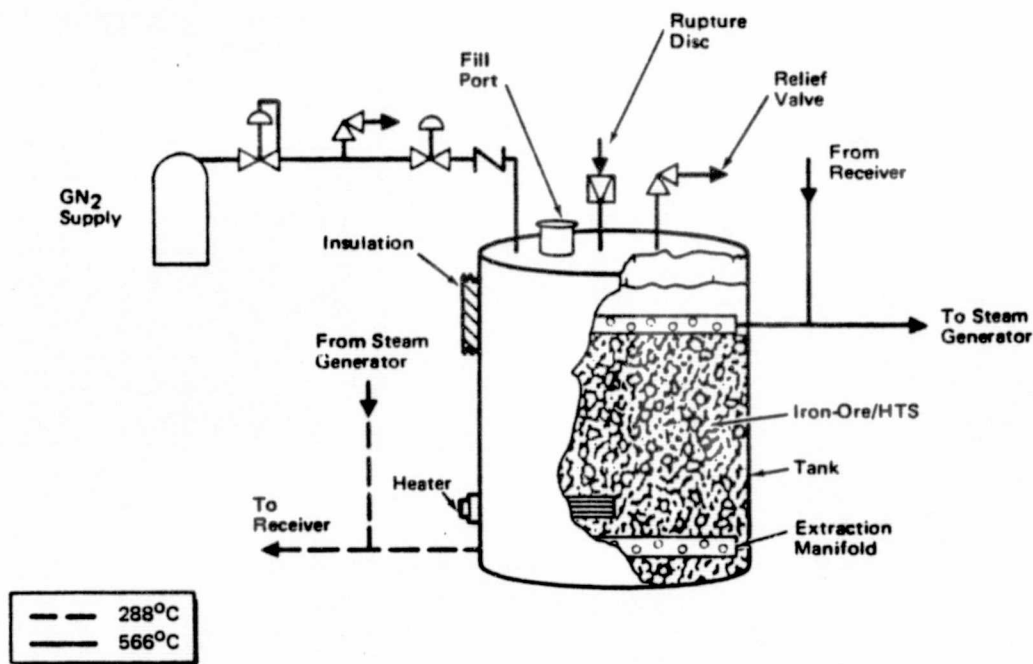

Figure 3-7. Dual Media Thermocline Energy Storage Subsystem

3.1.4.1 Storage Tank and Media

A single, vertically mounted, stainless steel tank is used to contain molten HTS and iron ore. The iron ore will have a void volume of approximately 40 percent which is filled with molten HTS. Colder HTS will be drawn from a manifold located at the tank bottom, pumped through the receiver and returned to the manifold located in the top of the tank. Hotter HTS will be extracted from the top of the tank, pumped through the steam generator, and returned to the tank bottom manifold. The quantity of storage media is oversized by 10% to allow for the thickness of the thermocline. An additional 6% is allowed for excess fluid and manifolds and 3% for ullage space.

The diameter of the tank is 3.51 m and the height is 5.27 m, giving a height-to-diameter ratio of 1.51. Safety features include a pressure relief valve and rupture disk. Thermocouple wells, liquid level indicators, and a pressure transducer will be used to monitor tank conditions.

3.1.4.2 Insulation

The tank is covered with insulation and an aluminum weather cover. The insulation thickness (20.3 cm) was optimized for minimum energy cost. High-temperature mineral wool will be utilized.

3.1.4.3 Immersion Heater

A 100-kW immersion heater will be utilized in the tank to melt the salt during initial salt filling operations or following extended shutdown periods when the salt was allowed to freeze. The heater will also be used to maintain salt in the tank at operating temperature during long standby modes. Heat paths to upper fluid surfaces will be provided to prevent tank rupture during melting.

3.1.4.4 Gaseous Nitrogen Supply

Gaseous nitrogen is utilized to provide an inert blanket to prevent the formation of sodium hydroxide from atmospheric moisture and the formation of sodium carbonate from the absorption of carbon dioxide. These reactions would lead to increased melting points, corrosion, and precipitate formation.

The cover gas will bleed off when the internal pressure reaches 0.34 bars differential. Nitrogen will be supplied at 0.17 bars differential.

The design and performance characteristics of the principal components of the energy storage subsystem are shown in Table 3-2. HTS characteristics are described in Volume V, Section 10.1.

3.1.5 Energy Transport Subsystem

The energy transport subsystem, shown on Figure 3-8, consists of a receiver loop and a steam generation loop. In the receiver loop, cool HTS is drawn from the bottom of the dual media thermal storage tank, pumped through the solar receiver, and returned to the top of the thermal storage tank. In the steam generation loop, the HTS is drawn from the top of the thermal storage tank, pumped through the steam generator, and returned to the bottom of the thermal storage tank.

The system provides lines to facilitate warmup operations during startup and draining lines following shutdown.

The energy transport subsystem consists of the following major components:

- A. Pipe lines and insulation
- B. Trace heaters
- C. Molten salt pumps
- D. Valves and actuators

3.1.5.1 Pipelines and Insulation

All pipelines are standard schedule 40 pipes and are butt welded where possible. Ring joint flanges are used otherwise. The system layout is shown in Figure 3-9. Lines are designated by numbers which refer to specifications given in Table 3-3. All lines and valves are insulated with 10.2 cm of calcium silicate and protected with an aluminum weather cover. Joints are sealed with insulating cement. Pipe hangers and supports are not specified.

Table 3-2. Thermal Storage Description, Commercial System

Configuration	
One cylindrical tank, vertical axis, mounted on low density concrete.	
Tank Dimensions	
Inside Diameter	3.51 m
Height	5.27 m
Fluid surface height (566°C)	5.12 m
Thermal Performance	
Storage capacity	11.87 MWh
Storage temperatures	
Maximum	566°C
Minimum	288°C
Heat losses (% of extractable)	2.8
Solid Storage Medium	
Iron Ore Pellets (63% Fe)	
Total Mass	149,160 kg
Void Fraction	0.4
Liquid Storage Medium	
Heat transfer salt (53% KNO ₃ , 47% NaNO ₃)	
Total Mass	36,960 kg
Two manifolds spaced over cross section	
Tank Structural Details	
Fabricated of 316 Stainless	
Plate thickness	8.1 mm
Roof and sides covered with high temperature mineral fiber (block) insulation and aluminum weather cover	20.3 cm
Immersion heater	100 kW
Gaseous Nitrogen Supply	
Delivery pressure (differential)	0.17 Bars
Relief pressure	0.34 Bars

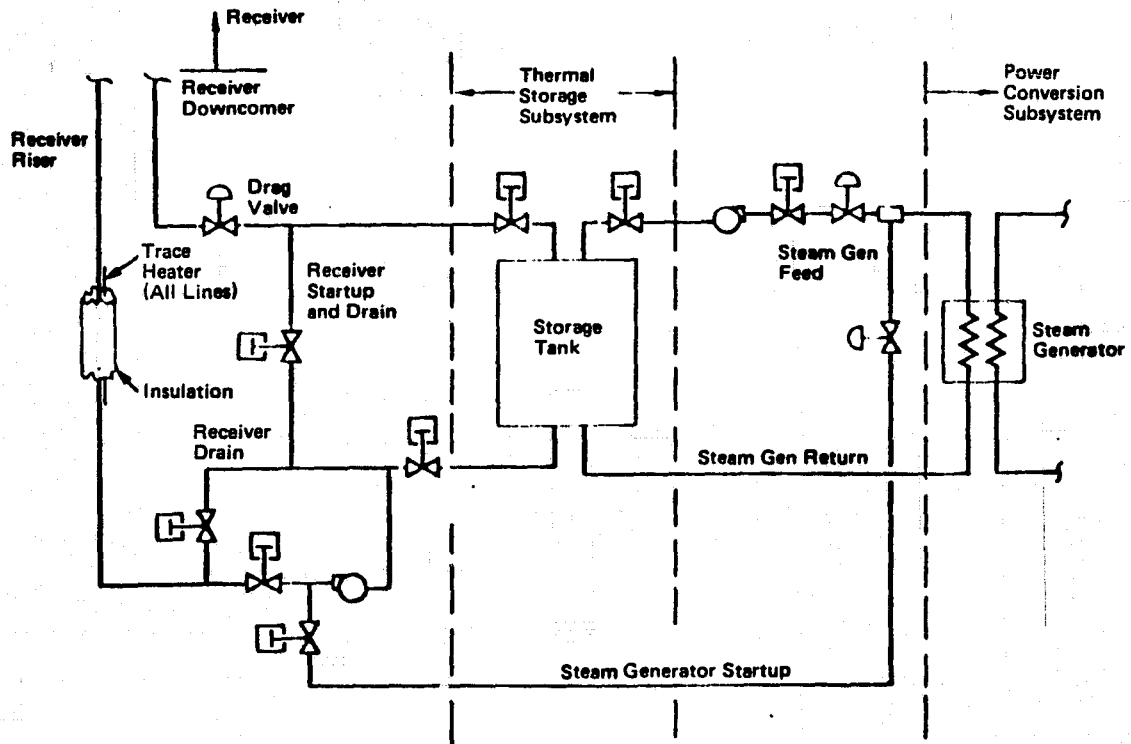

Figure 3-8. Dual Media Thermocline Energy Transport Configuration

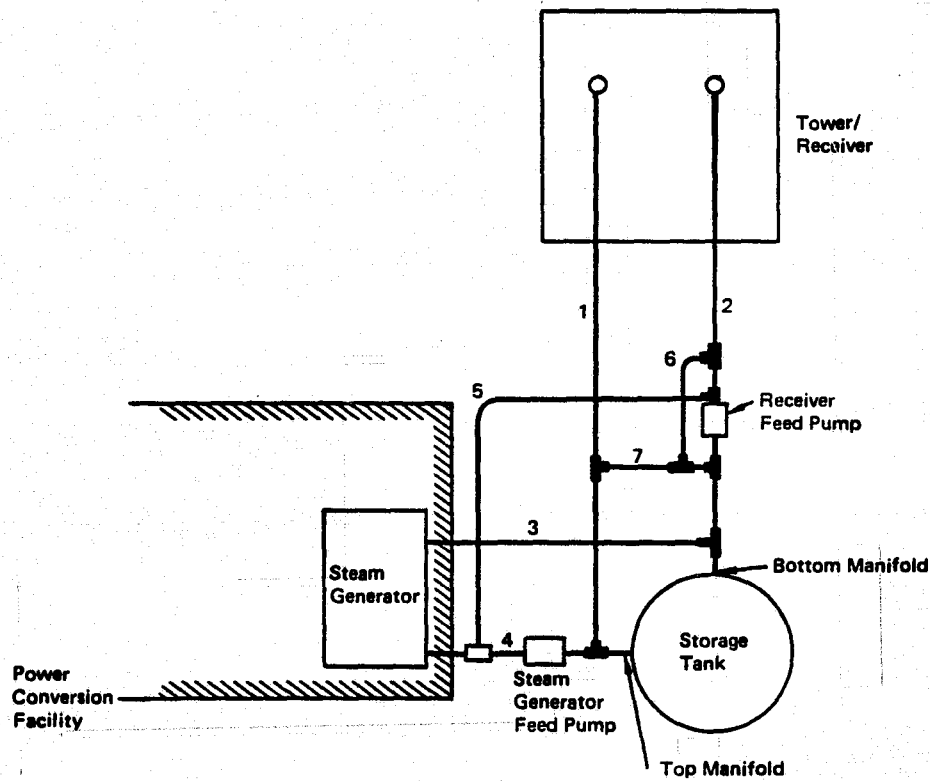

Figure 3-9. Energy Transport Layout, Commercial System

Table 3-3. Piping Specifications

Pipe* Line	Temperature (°C)	Size (cm)	Schedule	Material
1	566	6.4	40	Stainless 316
2	288	6.4	40	Carbon Steel
3	288	5.1	40	Carbon Steel
4	566	5.1	40	Stainless 316
5	288	5.1	40	Carbon Steel
6	566	6.4	40	Stainless 316
7	566	6.4	40	Stainless 316

*Numbers refer to pipe lines shown in Figure 3-9.

3.1.5.2 Trace Heaters

Trace heaters will be attached to all lines and valves and controlled such that the temperature of the heat transfer salt is maintained above the freezing point. All are electrical heating cables insulated with magnesium oxide and covered with a stainless steel sheath for high temperature operation. The control temperature is 260°C. The heaters will be attached to the lines with stainless bands and heat transfer cement prior to application of the insulation. Separate circuits are provided for each line listed in Table 3-3.

3.1.5.3 Molten Salt Pumps

Pumps will be of the horizontal, centrifugal, in-line type. The receiver feed pump operating at 288°C is presently available, but the steam generator feed pump, operating at 566°C, will require qualification of stuffing box seals which will probably be a grafoil ribbon. Specifications for both pumps are given in Table 3-4.

3.1.5.4 Valves and Actuators

The type and location of all valves are indicated in Figure 3-8. These are standard type valves and will be compatible with the operating temperature and size of the line in which they are located. All valves are rated at 21

Table 3-4. Energy Transport Description, Commercial Design

Component		Description
Receiver feed pump	Type	Centrifugal, in line
	Head rise	11.3 bar
	Design flow rate	39,180 kg/hr
	Drive power	13.6 kW
	Material	Carbon steel
Steam generator feed pump	Type	Centrifugal, in line
	Head rise	1.7 bar
	Design flow rate	23,074 kg/hr
	Material	Stainless steel
	Drive power	2 kW
Valve, remote (10)	Type	Shutoff, flow control
	Size	6.4 cm - receiver circuit 5.1 cm - steam generator circuit
	Pressure rating	21 bar
Valve, drag (1)	Type	Velocity control
	Size	6.4 cm
	Pressure drop	4-11 bars
	Material	Stainless steel
Piping	Size	6.4 cm - receiver circuit 5.1 cm - steam generator circuit
Insulation	Thickness	10 cm
	Material	Calcium silicate
Trace heating	Watts/meter	96 - receiver loop 87 - steam generator loop

Valves and lines operating above 430°C are stainless 316, otherwise carbon steel is specified.

bars and contain high-temperature asbestos gaskets. Remote control valves will use pneumatic actuators. The total subsystem utilizes three control valves and eight isolation valves.

The control valve located at the base of the receiver downcomer is a low noise type valve designed to dissipate the tower hydrostatic head.

3.1.6 Power Conversion Subsystem

The primary function of the power conversion subsystem (PCS) is to convert the thermal energy stored in the HTS into electricity. This electrical power

is then supplied to the electrical transmission network and to plant auxiliary loads.

The commercial PCS is nearly identical to the PCS of the 6.5-year program for EE-1 (as described in Volume III) the primary difference being a change of steam inlet conditions to 538°C (1000°F) and 138 bars (2,000 psia). The major components of the PCS are:

- Turbine-generator and ancillary equipment
- Steam generator
- Feedwater heaters and piping
- Pumps
- Condenser and air removal equipment
- Heat rejection equipment
- Water treatment
- Auxiliary power unit
- Instrumentation and control valves
- Switchgear and plant electrical network
- Wastewater pond

Piping and instrumentation diagrams of the feedwater/steam loop for the commercial program is shown in Figure 3-10. A brief description of the function of the loop follows.

Thermal energy is supplied to the PCS through the steam generator. HTS is fed to the steam generator where it passes through the superheater, boiler and preheater shells in a series arrangement and generates superheated steam at design conditions. The pressure and temperature of the steam is regulated by modulation of the HTS flow rate through the superheater, boiler and preheater. This steam is fed to the turbine through emergency stop and control valves in series. Steam is expanded through the turbine and extracted at one or more locations and pressures and used for deaeration and feedwater heating. The steam exhaust from the turbine enters the condenser and is condensed at a temperature of 42°C or less. Condenser vacuum is maintained by the use of a mechanical vacuum pump. The water level in the hot well is maintained by a level control valve which controls makeup water addition from the condensate storage tank. The level of water in the condensate storage tank is maintained by the demineralizer control system which activates the demineralizer when

REPRODUCIBILITY OF THE ORIGINAL PAGE IS POOR

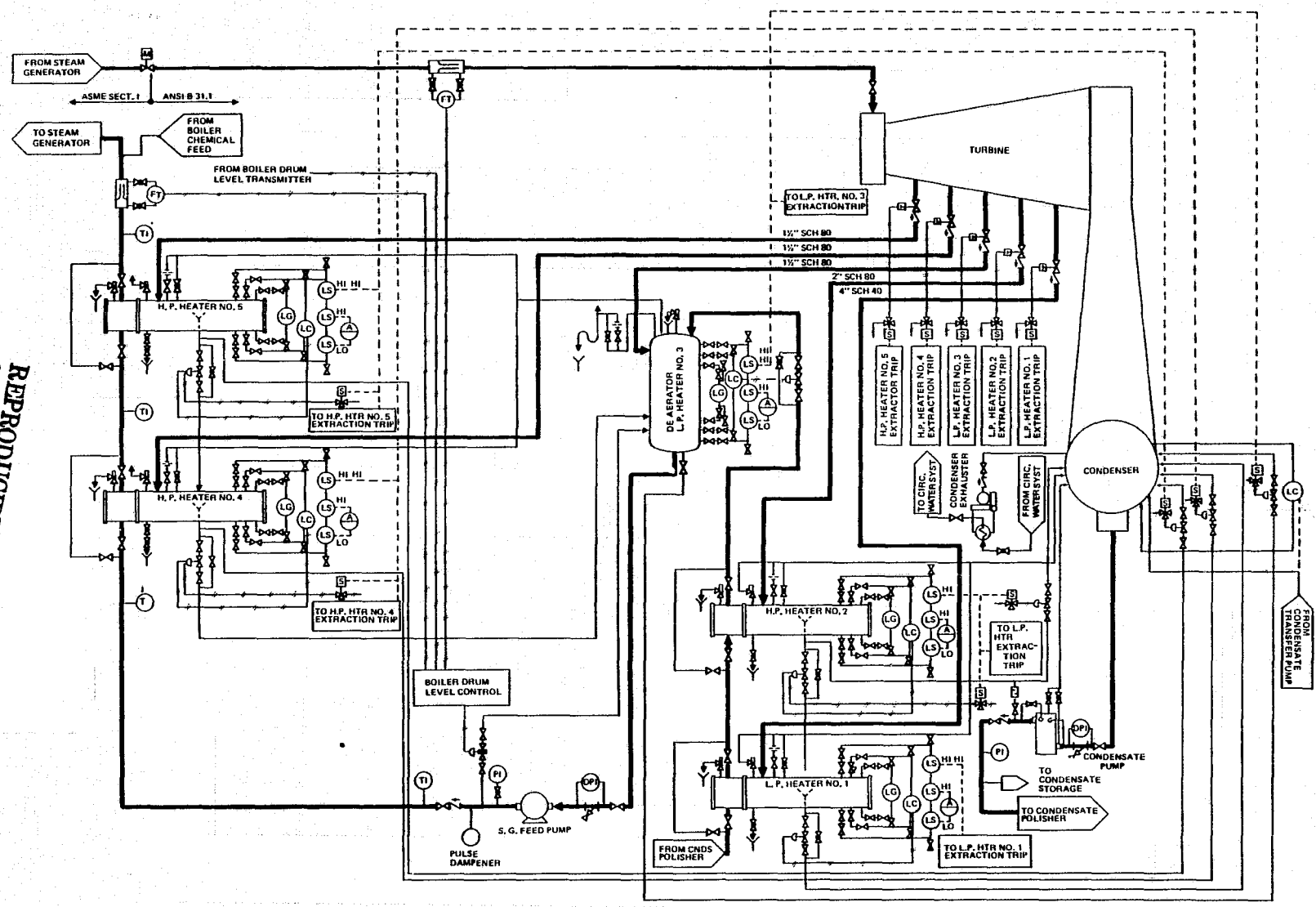

Figure 3-10. Steam, Condensate, Feedwater, Extraction Steam, Heater Vents, and Drains Flow Diagram for Commercial Program

the storage level falls below a specified quantity. Condensate can also be returned to the storage tank by opening a gate valve located at the condensate pump discharge. The condensate is pumped through the condensate polisher and closed feedwater heaters and delivered to the generator at a rate which is controlled by a deaerator level control. During low flow situations such as startup, condensate is also recirculated to the condenser through a flow restrictor. The deaerator also has a line leading back to the condenser to allow condensate to be dumped to the condenser if the deaerator becomes flooded. Extraction steam enters the deaerator, then raises the temperature of the condensate to saturation temperature. This saturated feedwater then enters the steam generator feed pump and is pumped to a pressure which is controlled by a recirculation line and valve. A control valve then regulates flowrate into the steam generator based on signals from flowrate transmitters and the boiler drum level transmitter. The feedwater then passes through the preheater and enters the boiler where it is converted to saturated steam, enters the superheater and is finally delivered to the main steam line.

3.1.6.1 Turbine Generator

The radial outflow turbine designed by ETI will be used in the commercial system. It is a high speed (12,000 RPM), 11 stage unit capable of expansion efficiencies of 0.84 with the steam inlet and outlet conditions available. A maximum of five uncontrolled extraction ports will be available for feedwater heating.

The gearbox will be a double reduction unit with double helical gears and will reduce shaft speed to 1800 RPM. This unit will also supply power to the gear driven main oil pump.

The turbine, gearbox and condenser will be assembled on a skid at the factory and tested before shipment. Overall dimensions of the turbine-generator without the condenser are shown in Figure 3-11. Ancillary equipment that will be mounted on the skid includes the mechanical vacuum pump and the lubrication system. The turbine design conditions are summarized in Table 3-5.

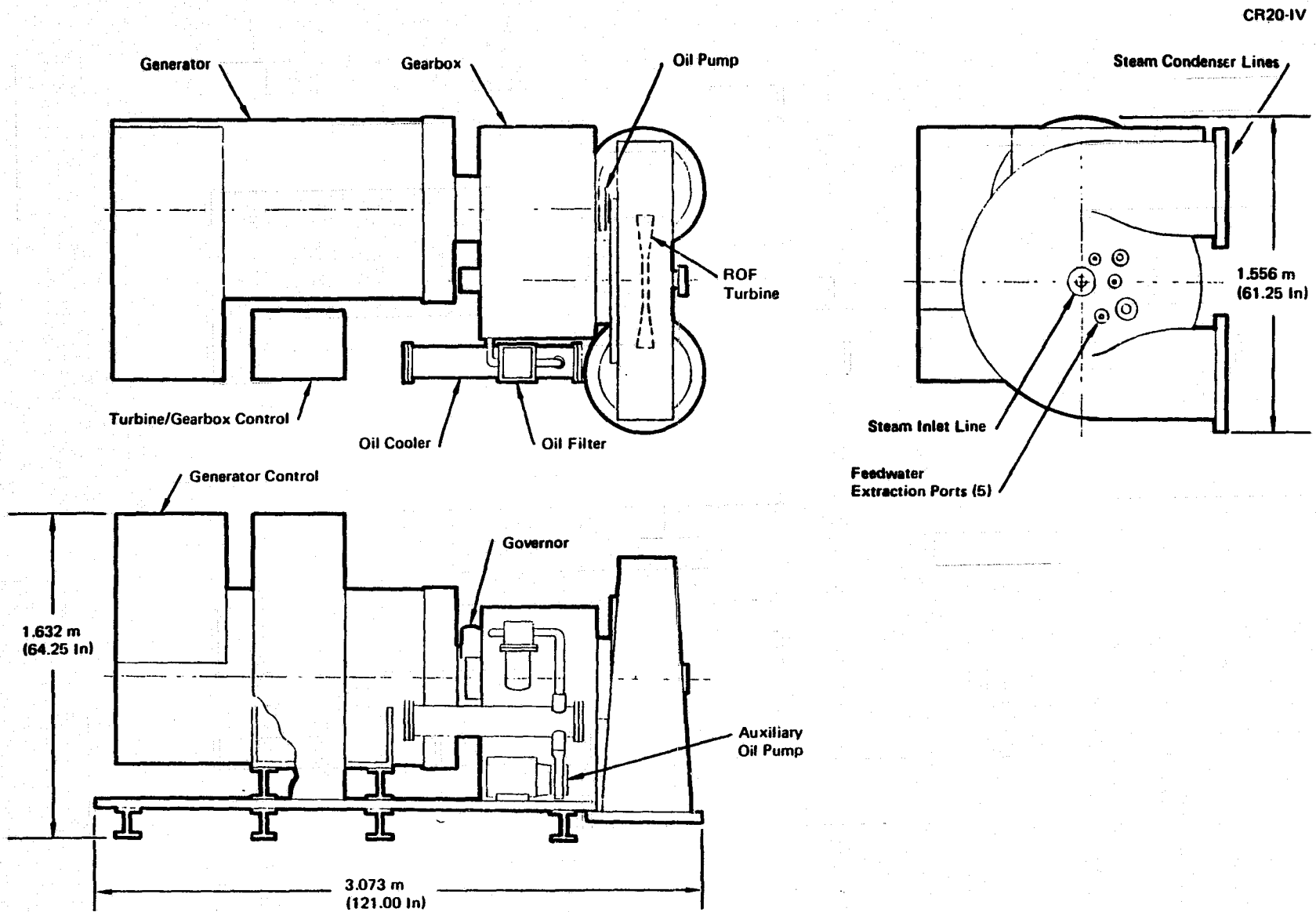

Figure 3-11. Radial Outflow Turbine/Gearbox/Generator Arrangement

Table 3-5. Turbine-Generator-Condenser Design Summary

Characteristic	
Overall	
Power Output, Gross	1,080 kWe
Net	1,000 kWe
Output Voltage	
Generator	4,160 V
Auxiliary Transformer	480 V
Turbine	
Inlet Steam Conditions	
Pressure, bars (psia)	138 (2,000)
Temperature, °C (°F)	538 (1,000)
Throttle Flow, kg/hr (lb/hr)	4,278 (9,434)
Condenser	
Type	Two Pass, Tube and Shell
Tube Material	Admiralty
Surface, m ² (ft ²)	22.7 (243)
Tube Diameter, cm (in)	2.54 (1.0)
Tube Wall Thickness	18 BWG
Tube Length, m (ft)	2.44 (8.0)
Condenser Pressure, bars (in. Hg A)	0.085 (2.5)
Heat Rejection (MWt)	1.70
Cooling Water Flow, kg/hr (gpm)	292,000 (1,294)
Cooling Water Out °C (°F)	34.4 (94)
Cooling Water In °C (°F)	29.4 (85)

3.1.6.2 Condenser and Air Removal Equipment

The condenser selected for the commercial system design is of the two pass shell and tube type using cooling tower circulating water for heat rejection. Tube material will be admiralty or a similar alloy. The condenser is sized for the highest heat rejection load that can be expected during full load operation. The heat rejection loads governing the condenser sizing are based on turbine exhaust flow conditions and steam generator thermal input minus extracted mechanical energy. A summary of the condenser design is given in Table 3-5.

The air removal equipment is required to remove air, nitrogen, and other non-condensable gases from the steam side of the condenser. This shall be accomplished using a mechanical vacuum pump with electric motor drive. The mechanical vacuum pump was selected instead of a steam jet ejector due to the lack of steam at start-up and to provide operational flexibility.

3.1.6.3 Steam Generator

The steam generator consists of separate preheater, boiler and superheater sections. The preheater section consists of two two-pass U-tube heat exchangers with a longitudinal baffle on the shell side. The boiler will be of the natural recirculation type with an elevated drum to provide separation of the steam and water. The superheater section is composed of a U-tube heat exchanger with longitudinal baffle. The preliminary design and operating parameters are given in Table 3-6. Also included in the steam generator is a line and control valve permitting the steam drum to blow down for removal of water impurities.

3.1.6.4 Feedwater Heaters

The radial turbine PCS utilizes five feedwater heaters consisting of one deaerator, two low pressure closed heaters, and two high pressure closed heaters. Tube material used in the low pressure heaters is 90-10 Cu-Ni while carbon steel was selected for the high-pressure heaters. The 90-10 Cu-Ni was selected over stainless steel because of better heat transfer capabilities. The closed heaters will be skid-mounted, two to a skid, with necessary

Table 3-6. Steam Generator Summary

Characteristic	
Overall Steam Generator	
Type	Natural Recirculation with Separate Preheater and Superheater
Manufacturer (Typical)	Struthers-Wells
Duty, MWt	2.78
Preheater Section	
Configuration	Two Identical U-Tubes in Series
No. of Passes	2
Mean Surface Area, m ² (ft ²)	18.8 (200)
Tube Size	0.95 cm (3/8 in) (BWG 18)
No. of Tubes	83
Tube Length Per Pass, m ² (ft ²)	2.13 (7)
Tube/Shell Material	Carbon Steel/Carbon Steel
Boiler Section	
Mean Surface Area, m ² (ft ²)	23.2 (250)
Tube Size	1.91 cm (3/4 in) (BWG 16)
No. of Tubes	143
Tube Length, m (ft)	2.95 (9.7)
Tube/Shell Material	Carbon Steel/Carbon Steel
Superheater Section	
Configuration	Horizontal U-Tube, Type CFU
No. of Passes	2
Mean Surface Area, m ² (ft ²)	13.4 (144)
Tube Size	1.27 cm (1/2 in.) (BWG 18)
Tube Length, m (ft)	2.74 (9.0)
No. of Tubes	66
Tube/Shell Material	304 SS/304 SS

instrumentation. The deaerator is a direct contact tray type deaerator utilizing stainless steel trays and a carbon steel shell. This unit is designed to reduce the dissolved oxygen in the feedwater to less than 0.007 cc/liter and is sized to store 10 minutes of feedwater at design flow rate. It will be elevated about 3 m to provide the required head at the boiler feed-pump which will be mounted on the same skid as the deaerator and the requisite level controls, valves, and alarms. A summary of the design parameters of the feedwater heaters is given in Table 3-7.

The remainder of the power conversion subsystem is identical to that of the 6.5-year experimental plant and will not be repeated here (see Volume III, Section 4).

3.1.7 Plant Control Subsystem

The plant control subsystem design for the commercial power plant is an extension of the system utilized in the EE No. 1 Program described in Volume III, Section 4. The commercial plant will operate automatically and in an unattended mode for daily power production. Manual and semiautomatic modes of operation are provided but used sparingly for testing and bringing the system on-line from a cold start.

The architecture of the plant, diagrammed in Figure 3-12, makes extensive utilization of the HAC computer facilities to coordinate and manage the plant controls in the automatic mode. A complete control system redundancy is provided with automatic failure detection and transfer to the backup system in the event a hardware or software fault occurs.

The implementation of redundant controls and the automation of the plant and plant support systems are the major hardware and software changes from the control system provided for the experimental programs. Any of the experimental programs provide the tools for gaining experience with automated control applications that leads to a fully automated commercial power plant control system.

Table 3-7. Feedwater Heater Summary (Page 1 of 2)

Characteristic		
Low Pressure Feedwater Heater	No. 1	No. 2
Duty, kJ/s (Btu/hr)	141 (479,000)	77 (264,000)
Feedwater Outlet Temp, °C (°F)	80 (175)	100 (213)
Extraction Temp, °C (°F)	82 (180)	103 (218)
Extraction Pressure, bars (psia)	0.5 (7.4)	1.15 (16.7)
Design Shell Pressure, MPa (psia)	1.7 (25)	3.45 (50)
Heater Drain Temp, °C (°F)	48 (118)	85 (185)
Terminal Difference, °C (°F)	2.8 (5)	2.8 (5)
Drain Cooler Approach, °C (°F)	5.6 (10)	5.6 (10)
Design Tube Pressure, bars (psia)	6.9 (100)	6.9 (100)
Tube area, m ² (ft ²)	4.23 (45.5)	6.7 (72.1)
High Pressure Feedwater Heater	No. 4	No. 5
Duty, kJ/s (Btu/hr)	187 (639,000)	307 (1,044,000)
Feedwater Outlet Temp, °C (°F)	186 (367)	250 (482)
Extraction Temp, °C (°F)	257 (495)	308 (586)
Extraction Pressure, bars (psia)	12.2 (177)	42 (605)
Design Shell Pressure, bars (psia)	13.8 (200)	48 (700)
Heater Drain Temp, °C (°F)	172 (309)	192 (377)
Terminal Difference, °C (°F)	2.8 (5)	2.8 (5)
Drain Cooler Approach, °C (°F)	5.6 (10)	5.6 (10)
Design Tube Pressure, bars (psia)	138 (2000)	138 (2000)
Tube Area, m ² (ft ²)	525 (56.5)	7.20 (77.5)

Table 3-7. Feedwater Heater Summary (Page 2 of 2)

Characteristic	
Deaerator	
Feedwater In	
kg/hr (lb/hr)	3,191 (7,036)
°C (°F)	100 (212)
J/g (Btu/lb)	418 (180)
H. P. Htr. Drains In	
kg/hr (lb/hr)	813 (1,793)
°C (°F)	154 (309)
J/g (Btu/lb)	653 (281)
Steam In	
kg/hr (lb/hr)	274 (604)
°C (°F)	157 (313)
J/g (Btu/lb)	2,763 (1,188)
Feedwater Out	
kg/hr (lb/hr)	4,278 (9,433)
°C (°F)	144 (292)
J/g (Btu/lb)	607 (261)
Shell Operation	
Pressure, Bars (psia)	4.1 (60)
Storage Capacity	10 Minutes at Full Flow
Type	Vertical, Tray Type
Material	Stainless Steel Trays, Carbon Steel Shell

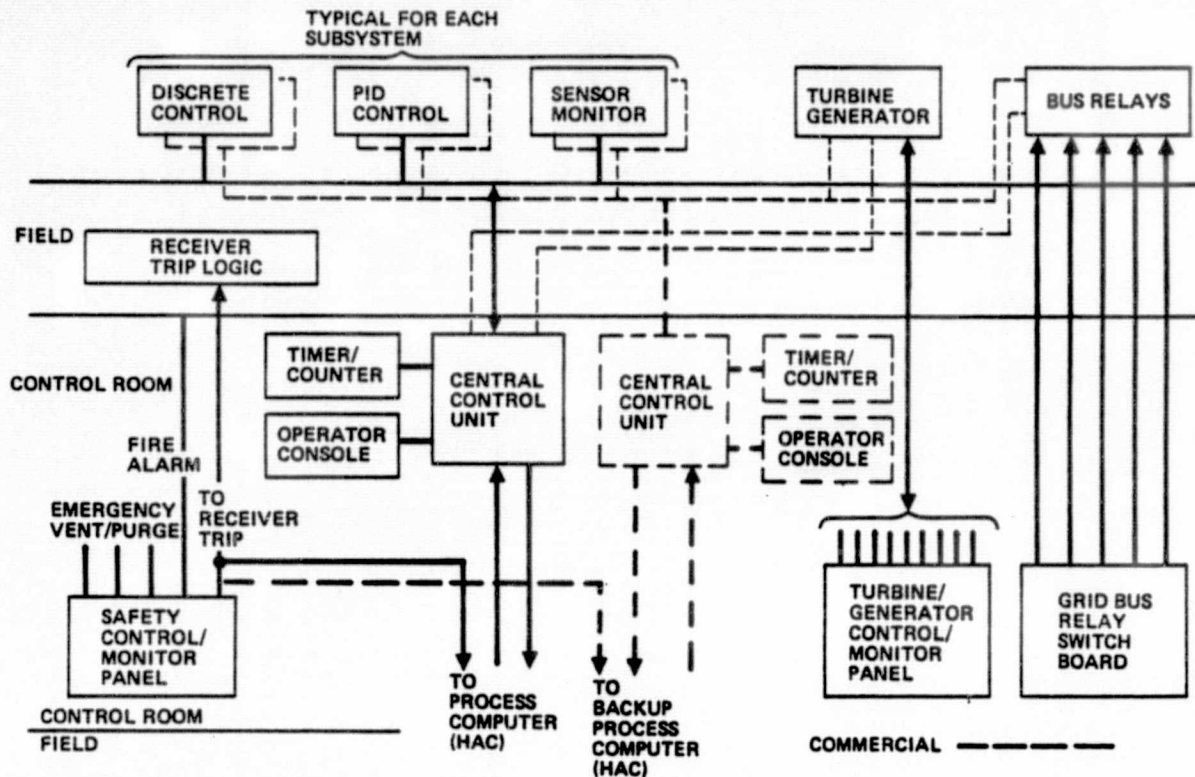

Figure 3-12. Plant Control System

3.2 OPERATIONAL CHARACTERISTICS

One of the key advantages of the system configurations is the flexibility of operation inherent in the design. Due to the use of separate energy transport loops between the receiver and storage and between storage and the power conversion subsystem, the operation of the PCS is entirely independent of the receiver/concentrator field operation. A detailed discussion of the plant operation is provided in Volume III for the 6.5-year system and is identical to that of the commercial system.

A typical integrated system operation is briefly described. The heliostats are oriented to the correct positions for receiver startup 15 to 20 minutes before receiver startup begins. The receiver startup will begin when the sun is 10° above the horizon, assuming cloud cover is not present. At approximately the same time, the startup of the power conversion subsystem begins. Fluid returning from the receiver that is out of spec during startup is returned to the cold storage tank or recirculated to the receiver until rated temperature is available. The steam generator is warmed up and begins to

supply steam to the turbine for warmup and startup. Once the turbine reaches speed, it shall be synchronized and loaded on the grid.

After the subsystems are started up, they enter the normal operation mode. During this mode, the thermal energy is absorbed at the receiver, transported to the energy storage subsystem at rated temperature, and used to generate steam at rated temperature and pressure.

During periods when intermittent cloud cover occurs, the receiver/energy transport subsystems will enter an intermittent operation mode where fluid flow in the receiver is modulated to maintain a constant rated outlet condition. Operation of the power conversion subsystem is unaffected during cloud cover.

Normal shutdown of the system will occur when the sun reaches 10° above the horizon or is covered by clouds for the remainder of the day. The heliostats will be stowed, receiver doors closed, and trace heating implemented. As the energy storage is depleted, the power conversion system will be taken off line and shut down.

During the evening, the system will be placed in the standby mode. During this mode, the plant control subsystem will monitor fluid temperatures and activate the trace heating elements as required to prevent the Hitec/HTS from solidifying.

The plant control subsystem will be monitoring the status of subsystems at all times. If a malfunction of one of the subsystems occurs, the plant control subsystem will warn the operator of the malfunction or automatically initiate an emergency shutdown procedure, depending on the seriousness of the malfunction. It will usually not be necessary to shut down the entire system. Instead, only those subsystems which are directly affected by the malfunction will be shut down. If a fault occurs in the receiver, then the power conversion subsystem can remain in the normal operation mode as long as energy storage is not depleted.

3.3 FABRICATION AND INSTALLATION CHARACTERISTICS

3.3.1 Fabrication of Subsystem Elements

Heliostat design is based on the 49 m² prototype heliostat currently under design and development at MDAC as part of a continuing DOE heliostat development program. Parallel DOE heliostat development and fabrication methods will be utilized directly by the commercial system.

The receiver will be a spiral-tube, cavity-cone configuration with an aperture diameter of 3.5 m. A maximum HTS film temperature of 650°C was used as a basis for design of tube size and flow routing. Tubes will be wrapped into a spiral into a spiral configuration. Towers for support of the receivers will be of the guyed steel design.

The thermal storage subsystem will employ a single tank using a dual media thermocline. The tank will be constructed of 316 stainless steel, which is adequate to withstand HTS maximum temperature. Electrical immersion heaters will be installed throughout the tank to prevent freezeup.

The energy transport subsystem will be comprised of standard pipes, sensors, control valves, and pumps. All pipes and equipment which will be exposed to HTS maximum temperature will be of 316 stainless steel. Low temperature elements will be of carbon steel. Horizontal centrifugal pumps will be used for circulating HTS.

The power conversion subsystem will employ an advanced radial turbine with five turbine extractions. Inlet steam conditions of 538°C, 138 bar, represent practical values subject to material and exit moisture constraints. Conventional condenser, feedwater heater, and heater rejection equipment will be used.

The plant control subsystem will employ hardware and software developed as part of the experimental programs. The configuration will minimize operator involvement, and will maximize the potential for unattended operation. All control commands will be initiated through a control processor or manually through a common keyboard.

3.3.2 Installation Flow Concepts

Installation of a commercial plant will follow the flow presented in Figure 3-13. Five different crews will perform the major tasks of surveying and grading, construction of facilities, mechanical installation, electrical installation, and plant startup. Each specialized crew will move incrementally to the next site as soon as their required service is complete, as shown in Figure 3-14.

Construction operations will include surveying, grading, and foundations for facilities and heliostats. All aspects of construction operations will be similar to the construction of experimental plants; however, for heliostat foundations, a drill rig will be used to drill holes, and a crane will be used to lower and set the steel-capped rebar foundation cages in place. Concrete will be poured to fill the excavation/rebar cages and tapered steel caps.

Figure 3-15 presents a comparison of installation support equipment for an experimental plant and for commercial plant. Note that equipment for deployment of commercial plants will be dedicated construction equipment and special installation equipment, as opposed to leased and contractor-supplied equipment for the experimental program.

3.4 MAINTENANCE AND REPAIR CHARACTERISTICS

Maintenance analyses were conducted on all components of the commercial system. Maintenance concepts were formulated to yield maximum system availability consistent with low costs. A summary of basic maintenance and repair philosophy is as follows:

- A. For field maintenance, failed line replaceable units (LRU's) will be removed and replaced. However, most forms of structural repair will be accomplished in-place.
- B. Initial spares were determined on the basis of a 30-day contingency, along with quantities required to fill supply pipelines. Locations of suppliers of spare parts were considered in determining order lead times.
- C. A 1-month turnaround was assumed for off-site repair.

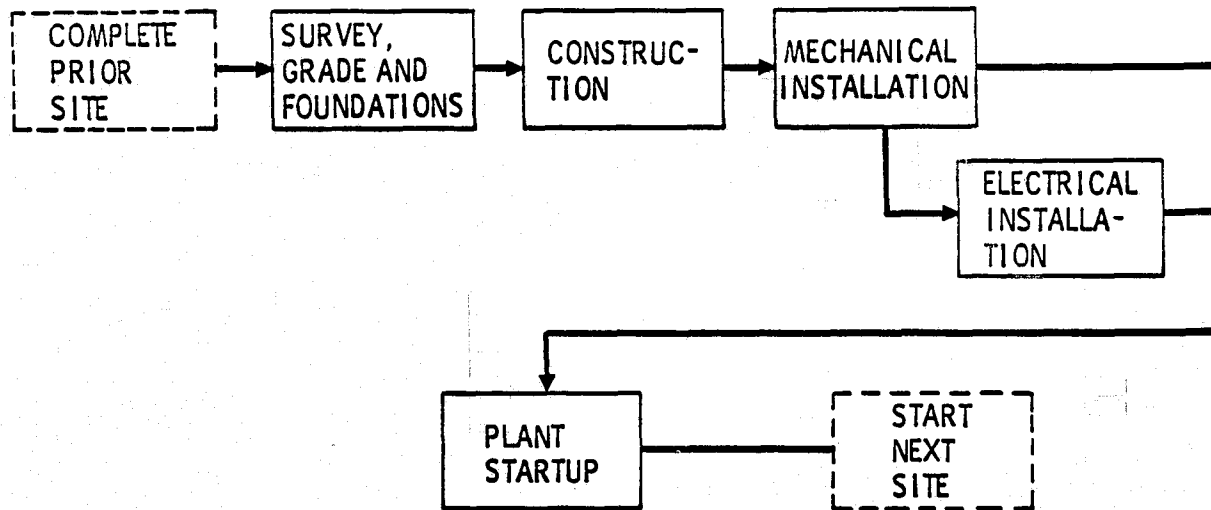

Figure 3-13. Commercial Plant Installation Flow

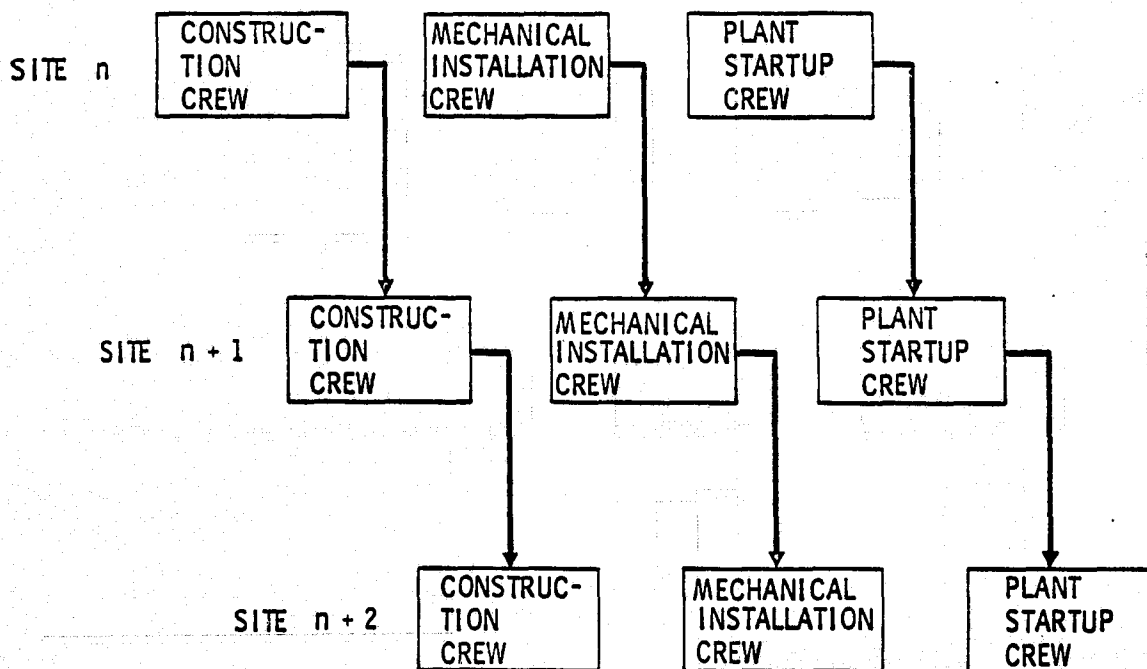

Figure 3-14. Crew Progression – Commercial Plant Deployment

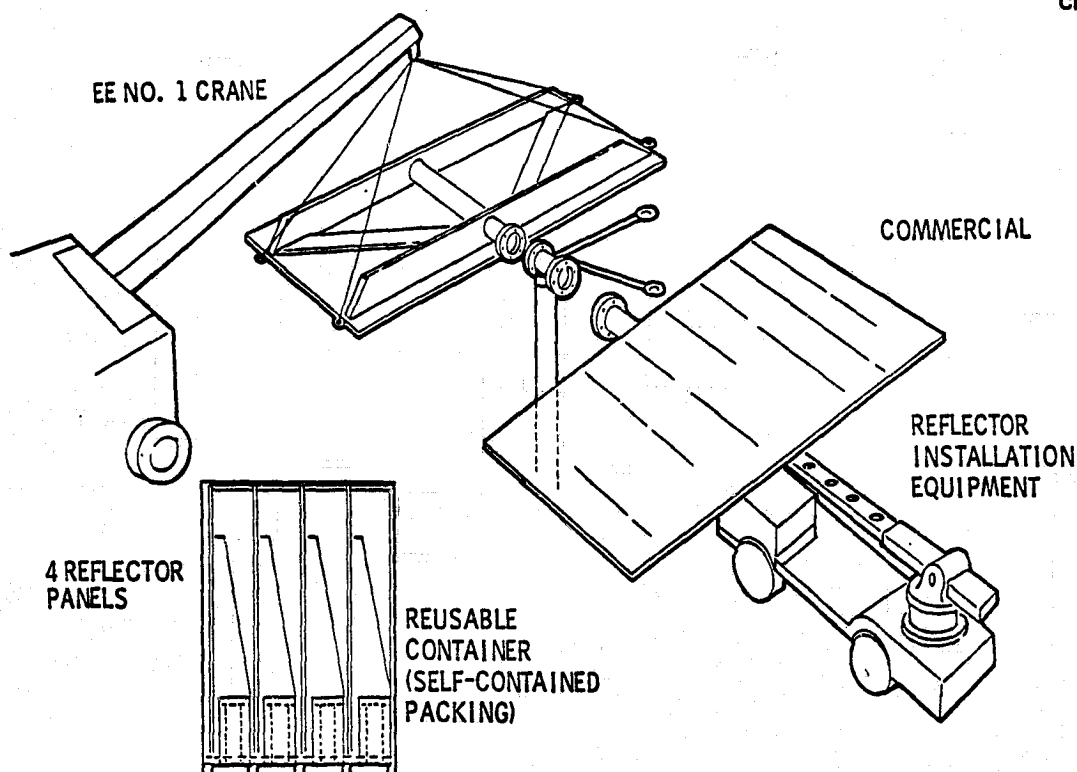

Figure 3-15. Heliostat Installation

Maintenance activities are categorized as follows:

- On-equipment scheduled maintenance
- On-equipment corrective maintenance
- Off-equipment, off-site repair

Summaries of manpower and spares requirements by the above maintenance categories, for each component, appear as Tables 3-8 through 3-10. Maintenance equipment is identified in Table 3-11.

3.4.1 Scheduled Maintenance

Scheduled maintenance requirements are summarized in Table 3-8. Periodic inspections include visual checks of each subsystem for corrosion, weathering, structural damage, condition of seals and bonds, fluid leaks, and audio evidence of malfunctions.

Cleaning of mirror modules involves a truck containing a cleaning agent in solution, and a deionized water rinse. A rate of 1 minute per heliostat was identified. The frequency of reflector cleaning is very site-dependent,

Table 3-8. On-Equipment Scheduled Maintenance, Commercial System

ITEM	ANNUAL FREQUENCY	TASK HOURS	CREW SIZE	POPULATION	ANNUAL MANHOURS	ANNUAL CONSUMABLES
COLLECTOR SUBSYSTEM:						
Heliostat Field Corrosion/Structural Inspection	1	4	2	1	8	0
Mirror Modules' Cleaning	12	.133/Hel	2	133 Hel.	424.54	80 gal. cleaning agent 10,374 gal. deionized water
Receiver Tower Leak/Corrosion Inspection	12	1	1	1	12	0
ENERGY STORAGE SUBSYSTEM:						
Visual Inspection for Leaks/Corrosion (Includes Energy Transport Subsystem Components)	1	1	1	1	1	0
ENERGY TRANSPORT SUBSYSTEM:						
Heat Exchanger Cleaning	1/3 years	48	2	3	96	0
POWER CONVERSION SUBSYSTEM:						
Turbine/Generator Oil Check	49	2	1	1	98	0
Turbine/Generator Trip Test, Gen. Winding Inspect.	4	4	1	1	16	0
Turbine/Generator Stop Valve, Gear Teeth Check	2	2	1	1	4	0
Turbine/Generator Oil System, Valves, Bearings Check	1	8	1	1	8	0
Turbine/Generator Vibration Test, Overhaul	1	180	3	1	540	0
Chem. Feed Tanks' Replenishment	25	1	2	4	200	0
Heat Exchanger Cleaning	1/3 years	48	2	6	192	0
Condensor Cleaning	1/3 years	48	2	1	32	0
Deaerator Cleaning	1/3 years	48	2	1	32	0

Table 3-9. On-Equipment Corrective Maintenance, Commercial System (Page 1 of 3)

ITEM	F/R 10 ⁻⁶	MTTR	CREW SIZE	POPULATION	ANNUAL MANHOURS	INITIAL SPARES	ANNUAL REP. SPARES	DISCARD FACTOR
COLLECTOR SUBSYSTEM:								
Power Cables	.108	1.5	2	133 sets	.17	2 sets	.055 sets	1.0
Control Cables	.108	1.5	2	133 sets	.17	2 sets	.055 sets	1.0
Heliostat Controller	5.79	2.2	2	128	12.59	2	.143	.05
DDI	9.74	2.2	2	5	.83	2	.009	.05
Motor, Elev. and Az.	2.0	1.9	2	266	7.81	2	.103	.05
Harmonic Drive	1.65	4.0	4	133	13.56	2	.042	.05
Linear Actuator	2.94	2.2	2	133	6.64	2	.075	.05
Optical Encoder, Az.	1.35	2.7	2	266	7.49	2	.069	.05
Optical Encoder, Elev.	1.35	1.1	2	399	4.58	2	.104	.05
Pedestal	0.1	1.0	2	133	.23	0	0	0
Structure	0.5	1.5	2	133	1.75	0	0	0
Mirror Module -	6.0/Hel.	2.0	2	133 Hel.	27.96	2	6.99	1.0
Storage Motor	2.0	1.9	2	133	.17	2	.002	.05
Storage Linear Actuator	2.94	2.2	2	133	.28	2	.003	.05
Field Control Cables	.108	2.5	2	133 sets	.28	2 sets	.055 sets	1.0
Field Power Cables	.108	2.5	2	133 sets	.28	2 sets	.055 sets	1.0
Az. Limit Switch	1.87	2.0	2	266	7.68	2	1.921	1.0
Elev. & Stor. Limit Switch	1.87	1.1	2	532	8.45	2	3.841	1.0
Circuit Breaker & Switch	1.0	1.6	2	133	1.64	2	0.514	1.0
HAC/Field Control Cables	.108	2.5	2	5 sets	.01	1 set	.002 sets	1.0
HAC/Field Power Cables	.108	2.5	2	5 sets	.01	1 set	.002 sets	1.0
Absorber	1.6	14	4	1	7.850	0	0	0
Absorber Support Struct.	1.0	10	4	1	.350	0	0	0
Absorber Door	1.0	8	4	1	.280	0	0	0
Absorber Piping	1.0	12	4	1	.420	0	0	0
Vent Valve	*5.23/d, 1.72/ hr	5.2	2	1	.109	1	.001	.05

* 1 demand/week

MCDONNELL DOUGLAS

Table 3-9. On-Equipment Corrective Maintenance, Commercial System (Page 2 of 3)

ITEM	F/R 10 ⁻⁶	MTR	CREW SIZE	POPULATION	ANNUAL MANHOURS	INITIAL SPARES	ANNUAL REP. SPARES	DISCARD FACTOR
COLLECTOR SUBSYSTEM: (Cont'd)								
Relief Valve	10	4.5	2	1	.347	2	.002	.05
Trace Heating	10	20	2	1	1.544	0	0	0
Insulation	1.0	10	2	1	.077	0	0	0
Hand Valves	0.1	4.5	2	2	.006	1	0	.05
Sensors	1.0	4.0	2	20	.618	1 set	.077	1.0
Motor (Door)	2.0	3.0	2	1	.001	1	0	.05
ENERGY STORAGE SUBSYSTEM:								
Hand Valves	0.3	4.5	2	4	.042	1	0	.05
Check Valves	4.0	4.5	2	1	.139	1	.001	.05
Regulator	18.0	5.7	2	1	.792	1	.003	.05
Sensor	1.0	3.0	2	10	.232	1	.039	1.0
Relief Valves	10.0	4.5	2	1	.350	1	.002	.05
Heaters	0.4	10.0	2	10	.008	1	0	0
Tanks	1.0	10.0	2	1	.175	1	0	0
ENERGY TRANSPORT SUBSYSTEM:								
Control Valves	6.46	5.7	2	3	.853	2	.004	.05
Remote Valves	*5.23/d, 1.72/hr.	5.2	2	7	.761	2	.004	.05
Check Valves	4.0	4.5	2	1	.139	1	.001	.05
Hand Valves	0.3	4.5	2	25	.261	1	.001	.05
Pumps	*1000/d, 30/hr	9.7	2	2	18.120	2	.047	.05
Sensors	1.0	3.0	2	5	.116	1	.019	1
Heat Exchangers	1.8	10.0	2	3	.378	1	0	.02
Heaters	10.0	20.0	2	1	3.504	2	.002	.02
Mixer Tank	1.0	10.0	3	1	.263	0	0	0

* 2 demands/day

3-37

MCDONNELL DOUGLAS

Table 3-9. On-Equipment Corrective Maintenance, Commercial System (Page 3 of 3)

ITEM	F/R 10 ⁻⁶	MTTR	CREW SIZE	POPULATION	ANNUAL MANHOURS	INITIAL SPARES	ANNUAL REP. SPARES	DISCARD FACTOR
POWER CONVERSION SUBSYSTEM:								
Radial Turbine	102.0	40.0	3	1	42.889	0	0	0
Generator	80.0	40.0	3	1	33.638	0	0	0
Condensor	1.0	10.0	3	1	0.105	0	0	0
Tank	1.0	10.0	3	7	.736	0	0	0
Deaerator	1.0	10.0	3	1	0.105	0	0	0
Pump	1000/d, 30/hr.*	9.7	2	6	53.195	2	.137	.05
Control Valve	6.46	4.7	2	15	3.187	2	.017	.05
Hand Valve Type 1	0.3	3.5	2	149	1.096	2	.008	.05
Hand Valve Type 2	0.1	3.5	2	37	.091	1	.001	.05
Pressure Sensor	1.0	2.0	2	19	.266	2	.067	1.0
Level Sensor	1.0	2.0	2	19	.266	2	.067	1.0
Relief Valve	10.0	3.5	2	18	4.415	2	.031	.05
Remote Valve	5.23/d, 1.72/hr**	4.2	2	31	2.565	2	.015	.05
Flow Meter	12.0	3.5	2	2	0.589	2	.084	1.0
Level Meter	1.0	2.0	2	2	0.028	1	.007	1.0
Heat Exchanger	1.8	10.0	2	6	.757	0	0	0
Check Valve	4.0	4.5	2	15	1.892	2	.010	.05
Cooling Tower Structure	1.0	10.0	2	1	0.175	0	0	0
Cooling Tower Tanks	1.0	10.0	3	3	0.788	0	0	0
3-Way Valves	5.23/d, 1.72/hr**	4.7	2	12	1.111	2	.006	.05
Temperature Sensor	1.0	2	2	4	.098	2	0	1.0

* 1 demand/day
 ** 2 demands/day

3-38

Table 3-10. Off-Equipments Off-Site Repair, Commercial System (Page 1 of 2)

ITEM	ANNUAL FREQUENCY	TASK HOURS	CREW SIZE	POPULATION	ANNUAL MANHOURS SITE	FACTORY	REPAIR PARTS FACTOR
COLLECTOR SUBSYSTEM:							
Heliostat Controller	2.862	3.5	2	128	0	20.030	.4
DDI	.188	3.5	2	5	0	.658	.4
Motor, Elev. and Az.	2.054	2.5	1	266	5.135	0	.4
Harmonic Drive	.647	2.5	2	133	0	4.236	.4
Linear Actuator	1.510	5.5	1	133	8.304	0	.4
Optical Encoder, Az.	1.387	3.5	1	265	4.853	0	.5
Optical Encoder, Elev.	2.080	3.5	1	399	7.279	0	.5
Storage Motor	.044	2.5	1	133	.110	0	.4
Storage Linear Actuator	.065	5.5	1	133	.355	0	.4
Absorber	.140	8	1	1	1.121	0	.4
Vent Valve	.010	2.5	1	1	.026	0	.4
Relief Valve	.039	2.5	1	1	.097	0	.4
Hand Valves	.0008	2.5	1	2	.002	0	.4
Motor (Door)	.0002	5	1	1	.001	0	.4
ENERGY STORAGE SUBSYSTEM:							
Hand Valves	.00463	2.5	1	4	.012	0	.4
Check Valves	.01544	2.5	1	1	.039	0	.4
Regulator	.06950	2.5	1	1	.174	0	.4
Tanks	.00876	10.0	1	1	.088	0	.2
Relief Valves	.03861	2.5	1	1	.096	0	.4
Heaters	.00040	10.0	1	10	.004	0	.5

Table 3-10. Off-Equipments Off-Site Repair, Commercial System (Page 2 of 2)

ITEM	ANNUAL FREQUENCY	TASK HOURS	CREW SIZE	POPULATION	ANNUAL MANHOURS SITE FACTORY	REPAIR PARTS FACTOR
ENERGY TRANSPORT SUBSYSTEM:						
Control Valves	.07483	2.5	1	3	.187 0	.4
Remote Valves	.07322	2.5	1	7	.183 0	.4
Check Valves	.01544	2.5	1	1	.039 0	.4
Hand Valves	.02896	2.5	1	25	.072 0	.4
Pumps	.93400	16.0	1	2	14.944 0	.4
Heat Exchangers	.01892	16.0	1	3	.303 0	.2
Heaters	.08761	10.0	1	1	.876 0	.2
POWER CONVERSION SUBSYSTEM:						
Pump	2.742	6	1	6	16.452 0	.4
Control Valve	.3390	2.5	1	15	.847 0	.4
Hand Valve Type 1	.15663	2.5	1	149	.392 0	.4
Relief Valve	.63072	2.5	1	18	1.577 0	.4
Remote Valve	.30535	2.5	1	31	.763 0	.4
Check Valve	.21024	2.5	1	15	.526 0	.4
Hand Valve Type 2	.01296	2.5	1	37	.032 0	.4
3-Way Valves	.11820	2.5	1	12	.295 0	.4

MCDONNELL DOUGLAS

3-40

Table 3-11. Maintenance Support Equipment

Equipment Item	Function
Mobile Crane, Linkbelt HC-138, 65 Ton*	Used to position tower structure, absorber, energy storage tanks, heliostat pedestals and heliostat reflector panels for removal and replacement or component repair.
Mini-Cletrack Trencher-Bulldozer*	Dig and cover heliostat field cable trench.
Portable Control Unit	Operate individual heliostat for checkout and troubleshooting.
Service Link 1D22779	Secure reflector during elevation drive replacement.
Pedestal Leveling Fixture 1D22761	Level heliostat pedestal to foundation interface.
Mirror Panel Lifting Sling	Remove and replace mirror panel.
Forklift, Five Ton	Move and position heavy equipment.
Washing Truck	Transport cleaning solution and rinse water.
Welding Equipment*	For structural installation and repair of tower, absorber, heliostat structure, and piping.
One-Half Ton Pickup Trucks (2)*	Movement of workers and materials.

*Initial Installation Only

seasonal, and weather-dependent. MDAC has chosen a 1-month interval for cleaning as representative of long-term average cleaning rates.

Periodic flushing/cleaning of the many heat exchanger-type vessels throughout the power conversion subsystem will be required. Requirements were defined using previous experience with similar components subjected to similar environments, with their associated scaling/penetration rate data.

The turbine/generator requires special attention due to its criticality to system operation. These include periodic lubrication and visual inspection of critical, stressed parts; and a yearly overhaul. Periodic servicing of plant control subsystem hardware will be accomplished through a service maintenance contract with the supplier.

3.4.2 Corrective Maintenance

The on-equipment corrective maintenance tasks and maintenance manhours per task for each subsystem are summarized in Table 3-9. The estimated elapsed maintenance time and crew sizes are also indicated. Task elements considered include fault isolation, access time, component removal and replacement, and test and checkout time after fault correction. Certain items requiring on-equipment structural repair also appear on this table. Consideration will be given to nighttime repair for such items, based on trading economy vs. availability.

Table 3-9 summarizes the on-equipment maintenance man-hour requirements per year based on the predicted maintenance actions per year and the task manhours. The equipment quantities per site and the failure rates as derived from the reliability analyses are provided for reference. Discard factors for each item are included in this table. These represent the percentage of failed, removed components that are judged not economical to repair.

The individual component failure rates or mean-time-between-failure estimates were obtained largely from historical data on other but similar systems.

Off-equipment unscheduled maintenance consists of fault isolation and repair/overhaul of removed components, at a central maintenance facility. These data are detailed in Table 3-10.

Spares and Repair Parts

A preliminary spares analysis was conducted based on the hardware configuration and the mean-time-to-repair. Results of this analysis to identify spare LRU quantities are included in the tables described above. Repairable LRUs, upon failure, are removed from the system, placed in the repair cycle, and subsequently returned to spare stock inventory. Initial spares quantity for

these items is the sum of the pipeline quantity and a 30-day contingency supply. The quantity is equal to the maximum number of items in the repair pipeline at any given time and is based on the failure rate and the repair cycle time. A repair cycle time of one month is projected. The 30-day contingency quantity is equal to the number of predicted failures in a 30-day period, and provides a cushion in the event of delays in repair or delivery; as well as providing for a nonlinear failure rate, over time. The initial spares quantity will be procured and stocked at the central repair facility.

The discard factor represents the number of failures which result in the LRU being discarded instead of repaired, primarily due to extensive damage. The product of the total number of failures per year and the discard factor equals the number of replacement LRU's to be procured at the beginning of the second and subsequent years.

Consumables

A list of consumables appears as Table 3-12. These consist mainly of chemical solutions and deionized water for cleaning or for heat transfer fluid chemistry maintenance purposes.

3.5 SYSTEM SAFETY CHARACTERISTICS

The system safety analysis of a solar thermal power plant must be concerned with two general areas of safety, the conventional industrial or occupational safety controlled by law in various state and federal statutes and the specific hazards which are unique to a solar power plant. The small power system experiment presents a third area of special concern with the use of the HITEC molten salt as a heat transport fluid.

The general safety requirement is to provide a safe power plant for operating personnel and for the general public.

The specific requirements include the applicable Occupational Safety and Health Administration (OSHA) regulations of the Federal Government (Title 29 Chapter XVII Part 1910 for operations and Part 1926 for construction) and/or the OSHA regulations of the specific state where the facility is located. If the facility is located in California, for example, the State of California

Table 3-12. Consumables

Item	Quantity per year	Remarks
Deionized Water	10,842 gal	Mirror cleaning
Cleaning Agent	83 gal	Mirror cleaning
Gasoline for Cleaning Trucks		312 gal
Gasoline for Pickup Trucks		2,496 gal
Cooling Tower Makeup Water		6,453 acre-feet
Boiler Makeup Water		34,900 gal
Cooling Tower H ₂ SO ₄		550 gal
Cooling Tower Sodium Hypochloride		620 gal
Hydrazine		1.5 to 10 lb
Cooling Tower Scale Inhibitor		75 to 220 lb
Amine		75 gal
HCl		267 gal
Caustic Soda		1700 lb
Powdered Resin		60 lb

and the Federal Government have agreed that the California Division of Industrial Safety will monitor and control OSHA standards for industry in the State of California. Other specific requirements will include the American National Standards Institute (ANSI) requirements (ANSI C2-1973 National Electrical Safety Code, etc.), the National Fire Protection Association (NFPA) requirements (NFPA 70-1978 National Electrical Code), standards of the National Electrical Manufacturers Association, (NEMA), ASME Boiler and Pressure Vessel Code, Sections I, II, V, VIII and IX and other ANSI and NFPA codes concerning automatic fire detectors, air conditioning systems, blower

and exhaust systems, water cooling towers, hazardous chemical handling, elevators, building design loads, mobile ladder stands and scaffolds, mechanical power transmission apparatus, overhead cranes, etc., and the building codes of the specific locality. Air pollution criteria and water release regulations will also be determined by local authorities.

The eye protection criteria for exposure to visible light, developed by the U.S. Army Environmental Hygiene Agency (reference 1), will be utilized until appropriate Federal or State agencies publish a criteria.

A complete discussion of the system safety analysis is presented in Volume III and is omitted here.

3.6 UTILITY AND COMMUNITY INTERFACES

In order to determine the requirements and preferences that a utility company might have for a facility such as the one being studied, a number of utilities and communities were visited. Among those contacted were:

- Public Service of New Mexico
- Georgia Power Company
- Shennandoah Development Corporation
- Tucumcari Gas and Electricity
- City of Tucumcari
- State Energy Commission of Western Australia

The more important items of discussion and conclusions reached are presently below.

- A. There is a substantial variation in the local distribution voltage at which the plant would be tied into the grid. In some cases, mechanical provisions for interfacing with the grid already exist.
- B. A preference for wet cooling was indicated since water was not in short supply at most sites.
- C. A preference for internal (thermal) rather than external (battery) storage was indicated.
- D. Daily and annual power demand profiles were obtained for several sites. Daily demand profiles for a peak winter and summer day in Belen, New Mexico are shown in Figure 3-16. From this data, it can

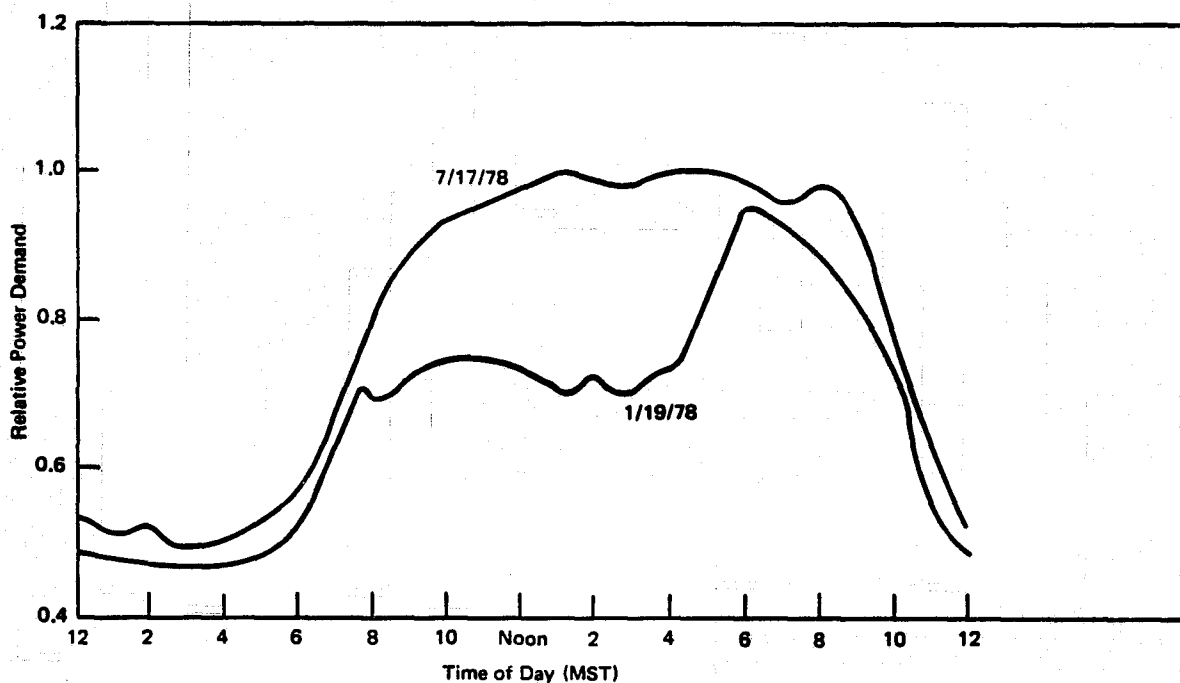

Figure 3-16. Power Demand Profiles for Belen, New Mexico

be seen that the demand for electricity lags the isolation availability by several hours. The power generation profile can be matched to the demand profile by the use of additional storage beyond that required by capacity factor considerations. The analysis of utility requirements also indicates a larger capacity factor of 0.50-0.52 is preferable.

3.7 STAND-ALONE CAPABILITY

The commercial plant, as presented in the preceding sections, is designed to interface with an existing electrical transmission grid. The plant can be modified to operate as a stand-alone unit in a location not serviced by a grid by making a few alterations.

The most obvious constraint placed upon a plant operating in this mode is that it must be capable of supplying the electrical demand 24 hours a day throughout the year. This can be accomplished in one of two manners:

- A. A diesel generator capable of supplying the plant rated power.
- B. A fossil fuel fired Hitec heater capable of supplying the heat input necessary for operation.

The diesel generator would provide a reliable, quick-starting source of electrical energy to make up that portion of the electrical load that the solar powered steam turbine could not provide. It would also provide a redundant power source for periods when the steam cycle is down for repair or maintenance. The increment in capital cost of such a system would be low, but operating and maintenance costs would be relatively high.

The second approach of a fossil fired heater placed in parallel with the receiver. This heater would function in a capacity identical to that of the receiver, taking the HTS from the energy storage at the "cold" temperature and returning it to storage at the "hot" temperature. This unit would not need to be sized for the same thermal output as that required by the steam generator since the steam generator (and PCS) would not be operating at full capacity 24 hours a day. The heater could then operate 24 hours a day at a reduced output and still supply the necessary energy per day. The use of the plant as a stand-alone unit would require operating the steam cycle 24 hours a day. This would eliminate the penalties associated with daily shutdown and start-up procedures such as thermal fatigue, water clean-up procedures, gaseous nitrogen blanketing, and make unsupervised operation less complicated. The capital cost of the fired heater is less than that of a diesel generator and the operating and maintenance costs are much less due to fewer moving parts and the ability to burn lower grades of fuel than a diesel can.

Assuming that the application is one that can tolerate occasional losses of electrical power, the HTS heater is the preferred approach due to lower costs and easier operation.

Additional equipment required in a stand-alone plant would be an electrical resistance bank to serve as a buffer for electrical load transients. This unit would be cooled using the cooling tower water. A slight change in the turbine control system would also be required. Speed of the turbine, and hence output frequency would be the primary parameter monitored for control purposes.

3.8 HANDLING AND TRANSPORTATION

3.8.1 Sizing and Weight Limitations

System elements will be transportable within applicable Federal and state regulations by highway and railroad carriers using standard transport vehicles and materials handling equipment. Whenever feasible, components will be segmented and packaged to sizes which are transportable under normal commercial transportation limitations. Subsystem components which exceed normal transportation limits will be transported with the use of special routes, clearances, and permits.

3.8.2 Shock and Vibration Limitations

Component packaging, handling, and tiedown will be compatible with standard commercial practices for highway, air, and rail transportation modes.

All critical components will be packaged such that transportation modes do not induce a dynamic environment condition which exceeds the structural capability of the component. These conditions reflect careful handling and firmly constrained (tied down).

Handling procedures should preclude shock resulting from drops of large packaged equipment.

Smaller components will be properly packaged to prevent structural damage during normal handling and inadvertent drops.

3.9 INSTALLATION AND CHECKOUT

3.9.1 Installation

Installation of the subsystems at the site will be accomplished using standard transportation and handling equipment. Factory-assembled components will minimize equipment and labor for field installation of structural, fluid, electrical, instrumentation and control interfaces.

3.9.1.1 Heliostat Installation

Heliostat subassemblies will be assembled and checked out in the factory. This concept maximizes the benefit of factory assembly (with attendant accuracies and efficiencies) and simplifies installation by minimizing tasks which must be performed in the field.

Four basic installations required for the heliostat subassemblies are foundation, drive unit, reflector panels, and cabling.

- A. Foundation--Foundation installation will be quick, economical and accurate to two degrees of vertical. The foundation provides proper support to the heliostat in normal operations and resists other positional movements that may result from environmental conditions (winds, temperature, rain, earthquake, etc.). The foundation will be an 0.61 m (2 ft) diameter drilled pier embedded 6.71 m (22 ft) in the ground. The drilled pier has a 1.22 m (4 ft) extension above grade formed by a galvanized-steel, tapered-tube section filled with concrete. The pedestal will be force-mounted on this pier extension.

The procedure for emplacing these drilled-pier foundations uses standard construction techniques. The cast-in-place concrete pier foundations can be used in a variety of soil conditions. The pier hole is excavated by drilling an open hole. The required reinforcing and concrete are placed as required to fill the hole. If the soil conditions are conducive to sidewall collapse, the pier can be placed by the Intrusion-Prepakt method, regardless of the sidewall stability. In this method, the hole is drilled and concrete grout displaces the soil as it is removed from the hold in a single operation. The reinforcing is forced into the grouted hole before the mortar begins to set. In any case, the pier is installed with the four-foot extension above grade which is subsequently encircled by a galvanized-sheet, steel-tapered tube section and filled with concrete. The equipment required to emplace the heliostat foundations are hydraulic cranes for lifting and manipulating iron work, and flat bed tractor/trailers for hauling the bracing materials. Hole drilling and concrete hauling equipment are used but are contracted for and included in the price of the service.

- B. Drive Unit/Pedestal Assembly--The drive unit subassembly is fully assembled and checked out at the factory. The factory checkout uses grease as a lubricant so that the drive unit need not have the oil drained before shipment.

Positioning requirements for the pedestal are as follows: the reference mark must be within $\pm 2^\circ$ of true North, the pedestal must be within 2° of local vertical, and the joint between the mating parts (foundation and pedestal) must be close to 0.8 mm (1/32 in) or less. The drive unit installation equipment was illustrated in Figure 3-15. The machine is capable of lifting the drive unit from the flatbed trailer, rotating to vertical, and rotating to a reference North-South alignment. A stereoscopic TV monitor assists the operator in placing the drive unit on the foundation. Loading and vibrators are incorporated to seat the drive unit on the foundation. The following procedure is used for installing the drive unit/pedestal assembly:

1. Lift the drive unit from the flatbed trailer with the drive unit installation machine to the vertical position.
 2. Lift the bottom end of the pedestal over the foundation and lower it over the tapered portion of the foundation.
 3. Adjust the position of the drive unit to true North.
 4. Engage the pedestal setting assembly of the pedestal installation machine, increase pressure and vibrate until the joint between material surfaces is 1/32 inch or less.
 5. Check the drive unit for verticality and adjust to $\pm 2^\circ$ of local vertical.
 6. Fill the drive unit with oil.
- C. Reflector Panel--Installation of the reflector panels to the drive unit is straightforward. All the critical positioning and aligning are done at the factory by either precision assembly, machined surface mating or jig-drilled holes.
- D. Cabling--Inter-heliostat wiring will be buried at least 24 in deep, and the primary power cables will be buried 30 in deep. Cables will not be trained in a straight or taut manner to allow slack for

settlement and earth moving after installation. Cabling installations will comply with safety regulations of various government levels (NEC, OSHA).

Installing cables involves using a machine that slices a V-groove in the soil to the desired depth, and then feeds the cable into the bottom of the groove before the soil is allowed to fall back in place. The advantage with this method is that the task is done in one automated operation.

3.9.2 Alignment and Checkout Concepts

3.9.2.1 Helio-stat Alignment

Helio-stat alignment will verify the basic operation of the helio-stat with respect to its components and other subsystems, and adjust the tracking software to compensate for installation physical tolerances. Individual helio-stat alignment is accomplished by open loop, therefore, there is no operational feedback to indicate misalignment. Accuracy of the initial alignment and subsequent alignments determines the relative efficiency of the helio-stat over its life cycle.

Mechanical adjustments are not required for the helio-stat after installation. Alignment is done by initializing and adjusting software relationships in the helio-stat controller to reflect the differences between the programmed placement of the helio-stat and the actual position of the unit. New initial position information is input on the first alignment, and on two subsequent alignments, angular track errors (verticality and skew) are removed.

During the alignment task, there can be no severe weather conditions that might interfere with accuracy. Wind must be below 26 mph so that a steady image will be projected on the target. Temperature extremes (<32°F and >120°F) must be avoided.

Precise orientation of each helio-stat will be required in order to optimize the accuracy of reflected beams on the receiver. Analyses have shown that errors of reference angles, tilt of azimuth axis from vertical, orthogonality

of elevation plane and azimuth plane, position of azimuth and elevation pivot points, latitude, longitude and time can degrade beam accuracy.

After installation of the heliostat on its foundation, the cant angles of each mirror module will be adjusted to allow for fault correction and fine tuning.

Each heliostat will be aligned using the sun, an active target, and a computer. Gimbal angles will be calculated for the most accurate reflection of the beam on the target. With an active target, the difference between the commanded image centroid and the achieved image centroid can be determined by visual observation.

With two independent measurements taken during the day, gimbal axis encoder readings will be used to construct four equations with four unknowns (two reference angles and two tilt angles). Correction angles obtained will be used in the heliostat controller software to control heliostat tracking on the target.

The detail alignment procedure for open-loop control of a heliostat is as follows:

- A. Latitude and longitude of foundation bench mark are surveyed. The south reference is surveyed. Angle accuracy is ± 5 degrees.
- B. The heliostat is installed so that the center of the azimuth pivot point is known to within 1 ft³ volume. The pedestal is then installed on the foundation so that the centerline is within ± 2 degrees of the local vertical. These tolerances are considered to be normal for field construction.
- C. A mobile test unit is connected to the heliostat controller. As an alternate, the heliostat can be operated in the control room.
- D. The heliostat is driven until mirror normal is at a standby tracking point (Figure 3-17).
- E. The heliostat array controller or computer is notified that heliostat X is ready for initial alignment, and the surveyed location information of this heliostat is stored in the computer memory.

- F. Gimbal angles are calculated to control movement resulting in the reflected beam hitting the alignment target. If the beam is not on target, an observer will identify necessary corrections. Gimbal axis readings and sun position are then recorded.
- G. While the reflected beam is on the target, the computer commands a 1- to 2-minute open-loop track. The reflected beam location on target is recorded.
- H. The heliostat is placed into an alignment standby mode where the reflected beam points at a space near the target.
- I. One to two hours later, the heliostat is commanded to point the reflected beam onto the target. After a 5- to 30-second period of open-loop tracking, the location of the beam is recorded.
- J. The heliostat is commanded to the stowage position. Alignment data for this heliostat are now in the computer permanent memory.

This procedure is illustrated in Figure 3-17, Heliostat Alignment.

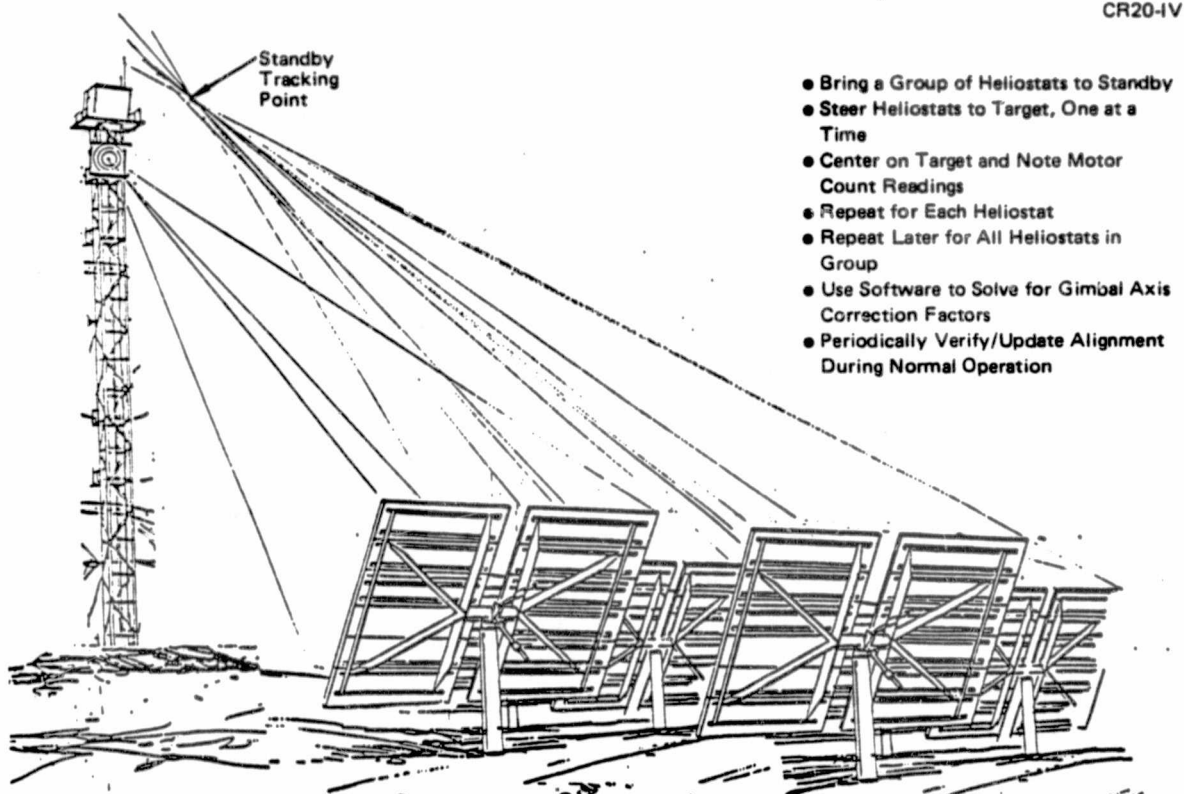

Figure 3-17. Heliostat Alignment

3.9.2.2 Plant Control System Checkout and Adjustment

Prior to commissioning the Small Power System plant for service, initial field checkout, adjustment, and tuning of plant controls will be performed. Each control point will be verified as operational prior to startup. Each subsystem will be tested to the operational extent possible. A final all-up control system integration test will be conducted in each of the plant operating modes to verify special supervisory control algorithms and fine-tuning adjustments of each control point.

3.10 COST SUMMARY

This section presents commercial system baseline costing results for investment, operations and maintenance and the resulting cost of energy projections.

3.10.1 Costs

Table 3-13 presents the costing results in 1978 dollars for the four specified rates of production. The cost category definitions are identical to those specified by JPL for Table E-2, "Phase III Engineering Information Summary." The costs reflect the sizing, design, logistics and programmatic variables associated with the commercial system baseline which, in most respects, is very similar to the 6.5-year program configuration. The main differences are that plant control is fully automated, the receiver unit is slightly smaller, there are only 133 heliostats in the field and the tower is only 36 m high. Also, thermal storage requires capacity of only 11.9 MWh in order to provide the specified 0.4 plant capacity factor, the tower elevator is eliminated, and the turbine building is reduced to essentially a shedlike configuration.

3.10.2 Ground Rules and Assumptions

Costs have been developed based on the following major assumptions and ground-rules:

- A. Prices in 1978 dollars
- B. Eight percent fee applied to all costs
- C. Second Generation Heliostat production rate matches plant deployment rate--existing production lines
- D. Installation in the early 1990's timeframe
- E. Shared maintenance and installation resources
- F. Plants are identical

Table 3-13. 1 MWe Commercial System Costs, 0.4 Capacity Factor - 1978 Dollars

Cost Element	100/Yr	500/Yr	1000/Yr	5000/Yr
Collector	\$ 779	\$ 749	\$ 701	\$ 638
Power Conversion	843	781	756	702
Energy Transport	91	83	80	72
Energy Storage	150	140	135	127
Control	205	194	190	181
Other*	448	448	448	448
Total Investment	\$2,516	\$2,395	\$2,310	\$2,168
Annual O&M				
Materials and Nonlabor	\$ 20	\$ 20	\$ 20	\$ 20
Maintenance Labor	57	57	57	57
Manager/Operator	28	28	28	28
Total O&M	\$ 105	\$ 105	\$ 105	\$ 105
Energy Cost (M/KWH)	169	165	161	156

*Special features, construction manager, miscellaneous equipment, fee, etc.

- G. Prepackaged power conversion subsystem
- H. 6.5-year program adjusted for First Commercial Plant baseline
- I. Operations, support equipment and services consistent with a small, austere, rural operation--automated control

One special note is that the prepackaged concept in effect applies to almost all of the equipment in addition to the Power Conversion Subsystem. This provides substantial field labor savings and allows a more effective cost reduction curve.

These groundrules and assumptions are supplemented by those shown in Table 3-14 for purposes of developing the cost of energy calculations. These constants were provided by the July 1978 JPL letter on Phase I Study data. The cost of energy calculations have been developed using the JPL-provided cost of energy calculation program, which is based on the ERDA/EPRI cost of energy model.

3.10.3 Costing Approach

Generally, the costing approach has been to employ the 6.5-year program costing results in order to develop a baseline first unit cost. The costing approach for the 6.5-year program is described in the appendix of Volume V. Essentially, the costs for major or important equipment items have been obtained from vendor quotes while prices for common items such as steel or lessor equipment have been obtained from catalogs or the contractor's cost data base. Labor costs are based on resource loads, standards, and historic factors.

Basic labor and material estimates are extended by various factors in order to bring estimates up to experience levels. Labor includes factors for visibility, setup, efficiency, rework/scrap, shop liaison, and processes such as passivation. Also, allocations have been made for quality control, production control and planning, sustaining tooling, product support and other miscellaneous expense. Material dollars have been factored to include visibility, scrap, transportation, and material burden.

Table 3-14. Energy Cost Groundrules and Assumptions

JPL Recommended Assumptions

		\$5,000 Per Acre
A. Raw Land		
B. Cost of Capital to a "Typical" Utility	k	0.086
C. Rate of General Inflation	g	0.060
D. Escalation Rate for Capital Costs	g_c	0.070
E. Escalation Rate for Operating Costs	g_o	0.070
F. Escalation Rate for Maintenance Costs	g_m	0.070
G. Capital Recovery Factor (8.6%, 30 Years)	CRF_k, N	0.0939
H. Fixed Charge Rate, Annualized	FCR	0.1565
I. Accounting Lifetime	n	30 Years
J. System Lifetime	N	30 Years
K. Insurance + "Other Tax" Fraction	$\beta_1 + \beta_2$	0.020
L. Investment Tax Credit Fraction	α	0.100

MDAC Assumptions

M. Year of Base Costs	y_b	1978
N. Year of Price Estimates	y_p	1978
O. Year of Capital Expenditure	y_t	1990
P. Year of Commercial Operations Start	y_{co}	1991

Labor estimates are then extended by appropriate composite industry factory labor, fringe and burden rates for a plant doing the projected volumes of production. Current composite trade labor rates, fringes, and general contractor field support and equipment rental rates are applied to field labor hours.

The main exception involves the heliostat costs which are based on the results of the Prototype Heliostat Study (now called Second Generation Heliostat). The results of the Prototype Heliostat Study provided costs at rates of 25,000, 250,000 and 1 million heliostats produced per year. These costs were increased by a constant cost per heliostat to cover modifications for focus, electronics and field size, and then interpolated to determine cost per heliostat implied for each specified Small Central Receiver installation rate. Finally, these results are extended by the number of heliostat in the field to arrive at total heliostat cost. Because of the developmental nature of the heliostats and their large contribution to total costs, further description of how the Prototype Heliostat costs were derived is provided at the end of this section.

Costs for the remainder of the system have been adjusted parametrically and on an a priori basis to reflect changes in input variables and develop a first unit cost. These results were then adjusted in accordance with cost reduction curve logic as appropriate to arrive at a unit cost at the end of the tenth year of production for each studied production rate. Table 3-15 provides an indication of the factors that relate to these adjustments.

Operations and maintenance costs are based on both resource loading and direct estimates of hours, unit investment cost for replaced or spared parts, and on quotes or prior study information on operations materials such as washing solution. Spares and repair parts are the product of annual failures (based on failure rates tables), hardware unit costs estimated for investment, and repair or replacement factors. Corrective maintenance is the product of crew size and lapsed time or a direct hour estimate for bench labor, annual failures, repair factors for bench labor, and burdened labor rates. Scheduled maintenance is based on direct estimates or crew size and burdened labor rates, material quotes, and estimated frequencies. Results were factored to

Table 3-15. Cost Adjustment Rationale

Item	Cost Drivers	CRC Application
Land and Yard Work	Acres, % fixed cost	None
Turbine Building	Square feet, type	None
Power Conversion	MWe output, Steam Generator Mwt	Labor - 94% CRC to 1000th unit, then flat Equipment - 96% CRC
Plant Control	2.0X certain equipment for automatic control	Labor - 85% CRC to 1000th unit, then, flat Equipment 96% CRC
Tower	Square of Height	99% CRC
Receiver	Absorber Surface Area	96% CRC
Energy Transport	Pipe Diameter, Length, Pump Flow Rate, PSI, Mass Flow Rate	96% CRC
Energy Storage	Tank Volume, Quantity of HTS and Taconite, Tank Surface Area	96% CRC on Equipment
Other	Identical Nature of Plants	None

consider efficiency, added first year failures or problems, and refix where the first attempt at repair is not successful and must be redone. The O&M labor rate has been estimated at 15 dollars per hour.

3.10.4 Heliostat Costing Methodology

Costs developed for the Second Generation Heliostat study were used as a basis for costing. The approach employed in developing costs for the 25,000 heliostats per year scenario is based on annual resource loading for labor and, in the main, on vendor information quoted at the level of parts and materials required to support annual factory output. For certain electronic components that currently do not exist, the costs of like components were used based on the projection that demand will cause the required components to be produced in the near future. The balance of material costs (e.g., fasteners) are based on catalog prices, while transportation costs are based on the experience at MDC in Long Beach who operate their own transportation fleet.

Although manhours have been primarily developed through manning of the required factory equipment, direct support hours for planning, sustaining tooling, and produce support are currently based on standard factors. Quality control hours are derived by a specially studied factor for the Prototype heliostat. Other areas such as material handling and supervision are covered within the applied burden rates.

Various factors have been applied to the costs derived in the above manner. Material has been factored by visibility, scrap and rework, and fee. Labor hours have been adjusted to reflect scrap and rework, and efficiency. Fee is covered in the labor rate. Applied efficiency factors mainly cover impacts on lapsed time while other efficiencies are implicit in the crew loads. This is most apparent in the field where a crew of 7 may be accomplishing a task, but at any one time only 2 or 3 members may be actually involved at any one time.

For the rate of 25,000 units per year, cost reduction curves have been applied only to factory labor. In the 25,000 unit scenario, production is assumed to commence after 100,000 heliostats have been produced for pilot plants, demonstration plants, and first commercial plants, and to continue out to unit

600,000 for a total of 500,000 heliostats over 20 years. The manloads have been projected as those required at the start of the second year of rate production in the factory, or at unit 125,000. In order to arrive at unit hours in the tenth year of operations, labor has been extended down on 89 percent cost reduction curve from unit number 125,000 to the average hours for units 335,000 to 360,000. This is intended to reflect tooling improvements, more efficient alignment of material flows, and better utilization of manpower as the plant matures.

Applied labor and burden rates vary between factory, field, and operations. Factory rates are based on low side National average labor costs and MDAC burden and GA&A experience at volume production facilities. Installation rates are based on Riverside, California trade labor and fringe rates adjusted to allocate distributable cost. Both the factory and field rates include an 8 percent fee.

Section 4 SENSITIVITY TO RATED POWER CHANGES

The sensitivity of the commercial system design, performance, reliability/availability and cost of energy to changes in rated power was evaluated by altering the sizing of the system to produce 0.5 MWe and 10 MWe at a constant load factor of 0.4. This was accomplished by a combination of detailed analysis and trade studies on items of major importance and a parametric scale-up or scale-down of items which are of secondary importance. Those major items which were treated by detailed analysis or trade studies are:

- 10 MWe semi-cavity receiver vs. cylindrical receiver
- Concentrator field/tower height/aperture size optimization
- Energy storage sizing
- Power conversion cycle efficiency
- Parasitic power

Those items treated parametrically with scaling factors are:

- Pipe sizing
- Controls/instrumentation
- Energy transport/storage thermal losses
- Pump power

4.1 DESIGN AND PERFORMANCE IMPACT

A brief discussion of the results of the design analysis and trade studies on the items listed above and a description of the design and performance modifications in each of the subsystems are given below.

4.1.1 Collector Subsystem - Concentrator Assembly

The concentrator used in the two sensitivity cases is identical to that of the commercial system. Both cases utilize a north field with the only difference being in the number of heliostats which is given in Table 4-1. A 360° field was also considered for the 10 MWe case for use in conjunction with a cylindrical receiver but was rejected as being less cost effective.

Table 4-1. Power Level Sensitivity Design Summary

New Power Output, MWe	0.5	1.0	10.0
Capacity Factor	0.4	0.4	0.4
Gross Power Output, MWe	0.547	1.08	10.7
Turbine Expansion Efficiency	0.81	0.84	0.85
No. of Extractions	3	5	5
Cycle Efficiency (To electrical)	0.365	0.388	0.394
Thermal Storage Capacity, MWht	7.4	11.9	105.3
Receiver Design Power, MWt	2.68	4.72	44.8
Receiver Aperture Diameter, m	3.5	3.5	8.0
Optical Height, m	34	34	90
No. of Heliostats	76	133	1312

The optimization study and results are presented below.

4.1.1.1 Concentrator Field Optimization

The purpose of the concentrator field analysis is to assure minimum cost thermal energy for each of the design points. The range of thermal power to be studied includes the thermal power necessary to operate a 1 MWe commercial plant with no storage requirements or with a 0.7 capacity factor. It also includes the thermal power requirements of an 0.5 MWe plant with a 0.4 capacity factor and a 10 MWe plant with a 0.4 capacity factor. This study will optimize the concentrator/tower/receiver parameters and determine the cost of energy for net thermal energy requirements of 5000 MWht to 100,000 MWht per year.

Field Optimization Methodology

The optimization analysis which is performed by the University of Houston is identical to that process described in Volume V and the description of it will not be repeated here. The input parameters are changed to represent commercial component cost and performance and are listed in Tables 4-2 through 4-4.

Table 4-2. Concentrator Field Optimization Input Parameters

Helioostat Cost	\$81/m ²
Helioostat Wiring Costs	
Cable	\$8.16/m
Trenching	\$6.95/m
Receiver Cost (Both Aperture Sizes)	\$102,000 $\left(\frac{P}{4.8}\right)^{0.65}$
	Where: P = Peak Pwr (MWt)
Tower Cost	
@ 34 m Optical Height	\$76,000
@ 38 m Optical Height	\$84,000
Riser/Downcomer Cost	\$23,000 $\left(\frac{\text{Power}}{3.7 \text{ MWt}}\right)^{0.5} (H_t + 4)/44$
Pump Cost (28 Hp @ MWt)	\$350/Hp
Land Cost	\$5,000/Acre
Fixed Cost	-0-
Helioostat Area	49.05 m ² (528 ft ²)
Receiver Loss Model	RL = 0.037 (Incident Power) + $\left(\frac{\text{Receiver Aperture}}{4.5 \text{ m}}\right)^2 (0.430 \text{ MWt})$

*Input Parameters For Optimization of All Concentrator Fields Except For 10 MWe Case

Information developed as a result of the optimization analysis includes a specification of the optimized cost of annual energy, the annual energy absorbed by the receiver working fluid, the peak power level, field shape and helioostat spacing data.

Receiver Interception Factor

The average annual receiver interception factor (AIF), which is a primary input to the concentrator field optimization analysis, is defined as the ratio

Table 4-3. Concentrator Field Optimization Input Parameters

10 MWe North Field	
Heliostat Cost	\$81/m ²
Heliostat Wiring Costs	
Cable	\$8.16/m
Trenching	\$6.95/m
Receiver Cost	\$1,400,000
Tower Cost	
At 90 m Optical Height	\$620,000
At 110 m Optical Height	\$735,000
Riser/Downcomer Cost	$\$23,000 \left(\frac{\text{Power}}{3.7 \text{ MWt}} \right)^{0.5} (H_t + 4)/44$
Pump Cost (4.5 Hp at 5.6 MWt)	\$350/Hp
Land Cost	\$5,000/Acre
Fixed Cost	0
Heliostat Area	49.05 m ² (528 ft ²)
Receiver Loss Model	RL = 0.037 (Incident Power) + 2.20 MWt

of the total annual energy collected within the aperture to the total annual energy redirected by the heliostat field. The AIF was computed for various locations in the concentrator field in order to develop contours of AIF levels in the field. This data was then used to develop AIF's for each cell location and this information was used as input by the University of Houston. The computer code CONCEN was modified to enable it to compute AIF for a circular aperture and used by MDAC to generate the AIF's for the following combinations of tower height and receiver sizes:

- A. 3.5 m Dia aperture, 34 m optical height
- B. 4.0 m Dia aperture, 34 m optical height

Table 4-4. Concentrator Field Optimization Input Parameters

10 MWe 360° Field	
Heliostat Cost	\$81/m ²
Helistat Wiring Costs	
Cable	\$8.16/m
Trenching	\$6.95/m
Receiver Cost (Both Aperture Sizes)	\$1,400,000
Tower Cost	
At 80 m Optical Height	\$636,000
At 70 m Optical Height	\$568,000
Riser/Downcomer Cost	$\$23,000 \left(\frac{\text{Power}}{3.7 \text{ MWt}} \right)^{0.5} (\text{Ht} + 4)/44.$
Pump Cost (45 Hp at 5.6 MWt)	\$350/Hp
Land Cost	\$5,000/Acre
Fixed Cost	-0-
Heliostat Area	49.05 m ² (528 ft ²)
Receiver Loss Model	RL = 0.05 (Incident Power) + 4.25 MWt
Receiver Size	6 m dia. x 9.4 m Ht

- C. 4.0 m Dia aperture, 38 m optical height
- D. 4.5 m Dia aperture, 38 m optical height
- E. 8.0 m Dia aperture, 90 m optical height
- F. 8.0 m Dia aperture, 110 m optical height

The resultant AIF's for each cell location for the six cases are presented in Figures 4-1 through 4-6.

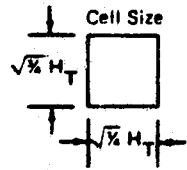

Aperture: 3.5 m
 Optical Height: 34 m
 Heliostat: 7.4 m x 7.4 m

0.7934	0.795	0.760	0.7323			
0.850	0.840	0.825	0.785			
0.8975	0.885	0.870	0.8468	0.780		
0.945	0.930	0.910	0.8758	0.815	0.740	
0.9734	0.975	0.9532	0.925	0.8822	0.790	
0.995	0.990	0.985	0.9381	0.885	0.8255	
1.0	0.997	0.990	0.950	0.8887	0.765	
1.0	1.0	0.980	0.930	0.810	0.700	
1.0	1.0	0.940	0.8106			
T						

Figure 4-1. Receiver Intercept Factors – Case 1

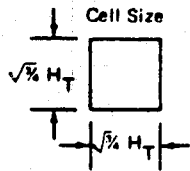

Aperture: 4.0 m
 Optical Height: 34 m
 Heliostat: 7.4 m x 7.4 m

0.5692	0.860	0.845	0.8172			
0.910	0.900	0.885	0.850			
0.9468	0.935	0.925	0.9075	0.825		
0.975	0.960	0.950	0.9292	0.840	0.785	
0.9906	0.990	0.9775	0.955	0.9289	0.830	
0.999	0.995	0.980	0.9653	0.930	0.8776	
1.0	.10	0.995	0.955	0.9260	0.815	
1.0	1.0	0.990	0.945	0.855	0.750	
1.0	1.0	0.96	0.8592			
T						

Figure 4-2. Receiver Intercept Factors – Case 2

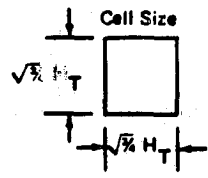

Aperture: 4.0 m
 Optical Height: 38 m
 Heliostat: 7.4 m x 7.4 m

	0.8199	0.815	0.790	0.7600			
	0.880	0.870	0.845	0.805			
	0.9213	0.915	0.900	0.8693	0.800		
	0.960	0.945	0.930	0.9025	0.815	0.775	
	0.9833	0.980	0.9646	0.940	0.9035	0.800	
	0.998	0.997	0.990	0.9531	0.915	0.8484	
	1.0	0.999	0.993	0.950	0.9103	0.780	
	1.0	1.0	0.990	0.945	0.850	0.740	
	1.0	1.0	0.960	0.8660			
T							

Figure 4-3. Receiver Intercept Factors – Case 3

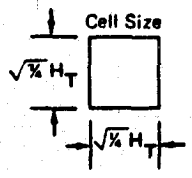

Aperture: 4.5 m
 Optical Height: 38 m
 Heliostat: 7.4 m x 7.4 m

	0.8830	0.875	0.860	0.8331			
	0.925	0.915	0.900	0.870			
	0.9597	0.950	0.940	0.9202	0.840		
	0.980	0.970	0.960	0.9449	0.865	0.780	
	0.9937	0.990	0.9826	0.965	0.9411	0.860	
	1.0	0.995	0.990	0.9729	0.940	0.8927	
	1.0	1.0	0.995	0.970	0.9384	0.830	
	1.0	1.0	0.990	0.960	0.870	0.760	
	1.0	1.0	0.975	0.9002			
T							

Figure 4-4. Receiver Intercept Factors – Case 4

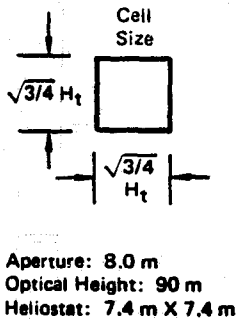

0.751	0.738	0.698	0.628	0.529	0.404	0.269
0.871	0.860	0.826	0.762	0.663	0.528	0.369
0.950	0.942	0.914	0.861	0.770	0.634	0.458
0.992	0.987	0.967	0.925	0.845	0.711	0.523
1.000	1.000	0.993	0.960	0.887	0.753	0.550
1.000	1.000	1.000	0.970	0.898	0.750	0.519
1.000	1.000	0.989	0.952	0.856	0.660	0.377
T	0.943	0.892	0.787	0.559	0.239	0.038

Figure 4-5. Receiver Intercept Factors – Case 5

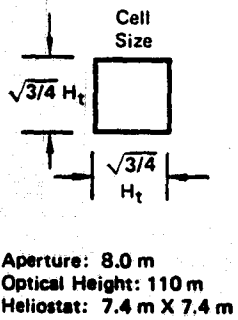

0.493	0.473	0.417	0.328	0.221	0.120	0.048
0.697	0.677	0.616	0.512	0.372	0.221	0.098
0.856	0.839	0.784	0.682	0.527	0.338	0.161
0.953	0.941	0.899	0.810	0.657	0.442	0.220
0.998	0.991	0.962	0.890	0.743	0.510	0.249
1.000	1.000	0.987	0.924	0.774	0.514	0.222
1.000	1.000	0.982	0.909	0.719	0.398	0.112
T	0.943	0.876	0.690	0.327	0.048	0.001

Figure 4-6. Receiver Intercept Factors – Case 6

In addition to the above cases which consist of north field configurations with a partial cavity receiver, two cases were considered utilizing a 360° field with an external cylindrical receiver. The receiver intercept factors for these two cases were generated by the University of Houston and are presented in Figures 4-7 and 4-8. These intercept factors are not true annual average but are instead the intercept factors for 21 days after vernal equinox at 3:00 pm. This time was selected to provide the most representative average sun position from a map of sun positions during the year.

Concentrator Field Optimization Results

The results of the concentrator field optimization analysis performed for the aperture/tower height configuration cases A-F are shown in Figure 4-9. The "Figure of Merit" parameter represents the capital cost divided by the annual thermal energy delivered to the base of the tower expressed by \$/MWht per year. Cost factors considered include heliostats, land, wiring, tower, receiver, piping and pumps..

The indicated values of the figure of merit were based on an insolation model defined by the University of Houston. This model results in an annual energy collection which is approximately 4.5% less than that which would be collected based on Barstow 1976 data. As a result, the predicted values of the figure of merit are about 4.5% higher than would be expected if the Barstow insolation model were used. The results presented in Figure 4-9 show that, of the four configurations considered, the 34 m optical height in conjunction with an aperture of 3.5 m dia is the preferred candidate for annual thermal energy requirements of 5 to 15 GWht. The preferred candidate for annual thermal energy requirements greater than 18 GWht is the 38 m optical height with 4.5 m dia aperture. It should be noted that the difference in figure of merit between all the candidates over much of the range considered is less than one percent, indicating that the parameters of tower height and receiver aperture are relatively insensitive near the optima.

The results presented in Figure 4-10 apply to the four configurations considered for the 10 MWe case. At the design point of approximately 100 GWht/year the north field with a 90 m optical height and 8.0 m aperture is the preferred configuration.

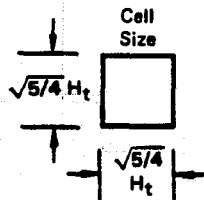

Cylindrical Receiver:
6.0 m Dia X 9.4 m High
Optical Height: 70 m

0.704	0.697	0.677	0.645	0.603	0.555	0.503	0.451
0.793	0.786	0.763	0.727	0.679	0.623	0.562	0.501
0.864	0.857	0.837	0.801	0.751	0.688	0.620	0.550
0.914	0.909	0.889	0.856	0.808	0.746	0.672	0.594
0.938	0.935	0.922	0.893	0.848	0.789	0.714	0.632
0.937	0.936	0.930	0.911	0.871	0.816	0.744	0.659
0.863	0.909	0.919	0.909	0.879	0.827	0.760	0.676
T	0.847	0.898	0.897	0.875	0.827	0.762	0.679
0.875	0.893	0.894	0.888	0.865	0.818	0.753	0.671
0.932	0.922	0.904	0.884	0.850	0.800	0.732	0.651
0.926	0.918	0.898	0.867	0.825	0.769	0.699	0.622
0.895	0.888	0.866	0.831	0.784	0.725	0.656	0.584

Figure 4-7. Receiver Intercept Factors – Case 7

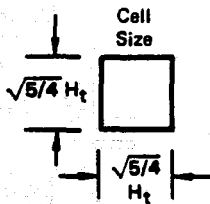

Cylindrical Receiver:
6.0 m Dia X 9.4 m High
Optical Height: 80 m

0.636	0.630	0.609	0.577	0.536	0.491	0.443	0.396
0.731	0.723	0.699	0.661	0.612	0.556	0.498	0.441
0.817	0.808	0.784	0.741	0.687	0.621	0.554	0.487
0.891	0.874	0.849	0.809	0.752	0.682	0.605	0.529
0.917	0.912	0.893	0.856	0.802	0.730	0.649	0.566
0.924	0.921	0.910	0.882	0.832	0.765	0.681	0.593
0.854	0.893	0.904	0.886	0.845	0.781	0.699	0.610
T	0.839	0.885	0.877	0.844	0.783	0.702	0.613
0.866	0.884	0.890	0.866	0.832	0.772	0.693	0.606
0.919	0.908	0.885	0.857	0.812	0.750	0.670	0.586
0.905	0.895	0.870	0.831	0.780	0.712	0.636	0.557
0.861	0.852	0.825	0.784	0.728	0.663	0.591	0.519

Figure 4-8. Receiver Intercept Factors – Case 8

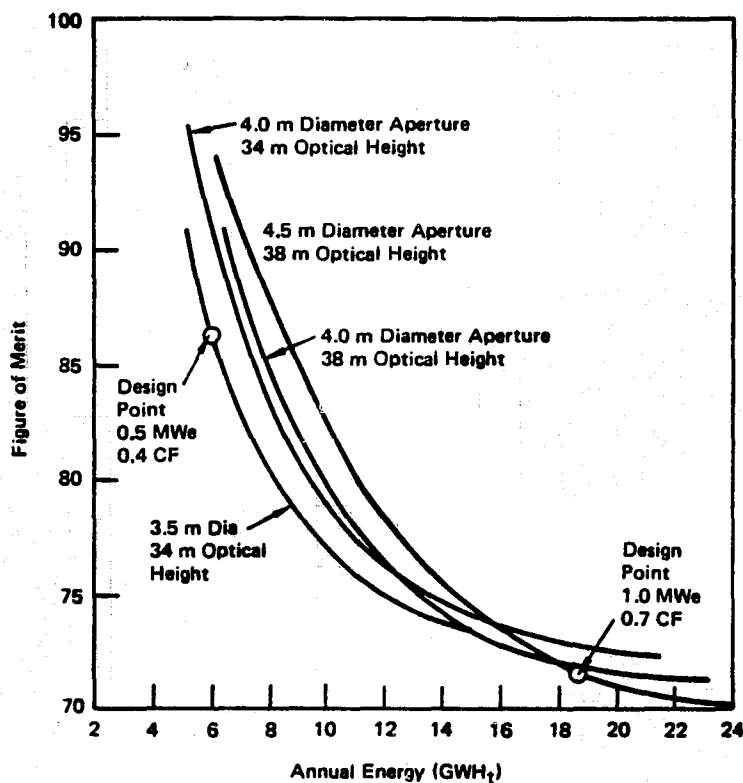

Figure 4-9. Commercial Field Optimization Results

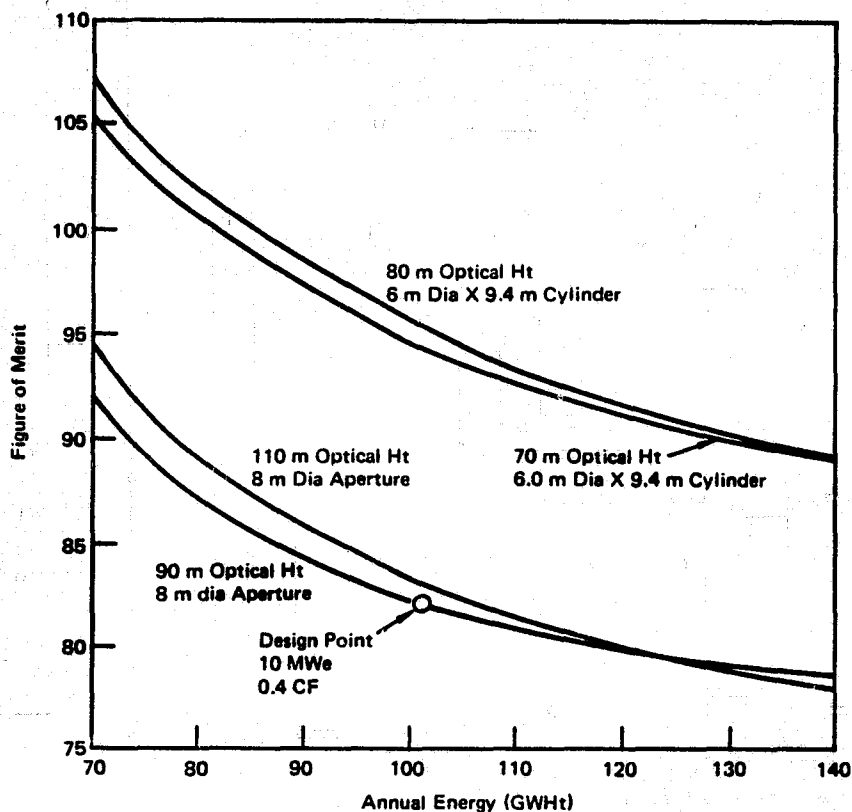

Figure 4-10. Commercial Field Optimization Results (10 MWe Case)

4.1.2 Collector Subsystem — Receiver Assembly

The receiver for the 0.5 MWe case is nearly identical to the commercial receiver, the absorber having a 3.5m diameter aperture identical to the commercial unit and having slightly less depth due to reduced power capability.

The receiver for the 10 MWe case is illustrated in Figure 4-11. It is also a partial cavity receiver, the major difference being the size and the construction of the outer rim. Aperture diameter and receiver depth has been increased to 8.0 m (26.2 ft). Because of its size, rather than being one piece similar to the commercial absorber, it is fabricated in four separate quadrants, each having a serpentine flow path which connects to the inner cone. The size of the separate sections allows them to be transported by truck from the factory to the site.

An external cylindrical receiver was also considered for application in the 10 MWe case. It was rejected on the basis of the concentrator field optimization results presented in Figure 4-10. A brief discussion of the design and performance characteristics of the two receivers follows.

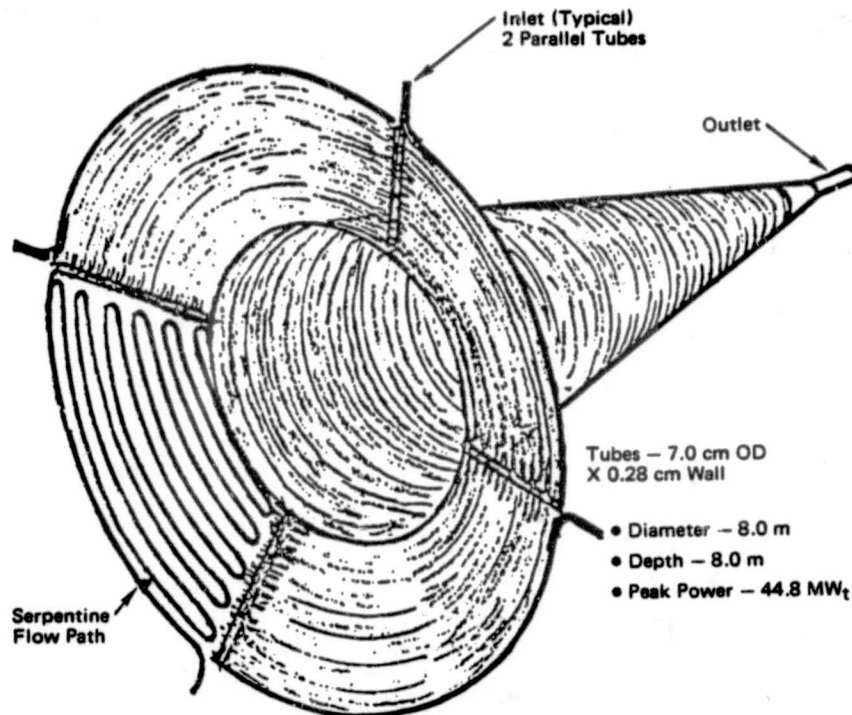

Figure 4-11. Partial Cavity Receiver 10 MW_e

4.1.2.1 Receiver Configurations for 10 MWe Power

Two receiver configurations were selected for the 10 MWe sensitivity analyses. These are, a HTS cooled cavity receiver north field concentrator configuration and a HTS cooled external cylindrical receiver configuration with a 360° concentrator field.

The cavity receiver is scaled up from the 1 MWe configuration preserving geometrical similarity. A range of aperture diameters between 8 and 10 meters was investigated. The effect of aperture diameter on thermal loss and on receiver weight was determined. Small receiver apertures are obviously preferred down to the diameter where decreased thermal loss is less than the increase in concentrated incident energy spillage. The optimum receiver diameter was determined to be 8 m.

Parametric sizing data for coolant velocity, pressure drop and number of parallel flow paths against tube inside diameter are shown in Figure 4-12 for the 8-meter diameter cavity receivers. Design characteristics are shown in Table 4-5. The selected design point has eight parallel flow paths and a tube pressure drop of 250 kPa (36 psi). Figure 4-13 shows a side view of the two-zone conical spiral configuration.

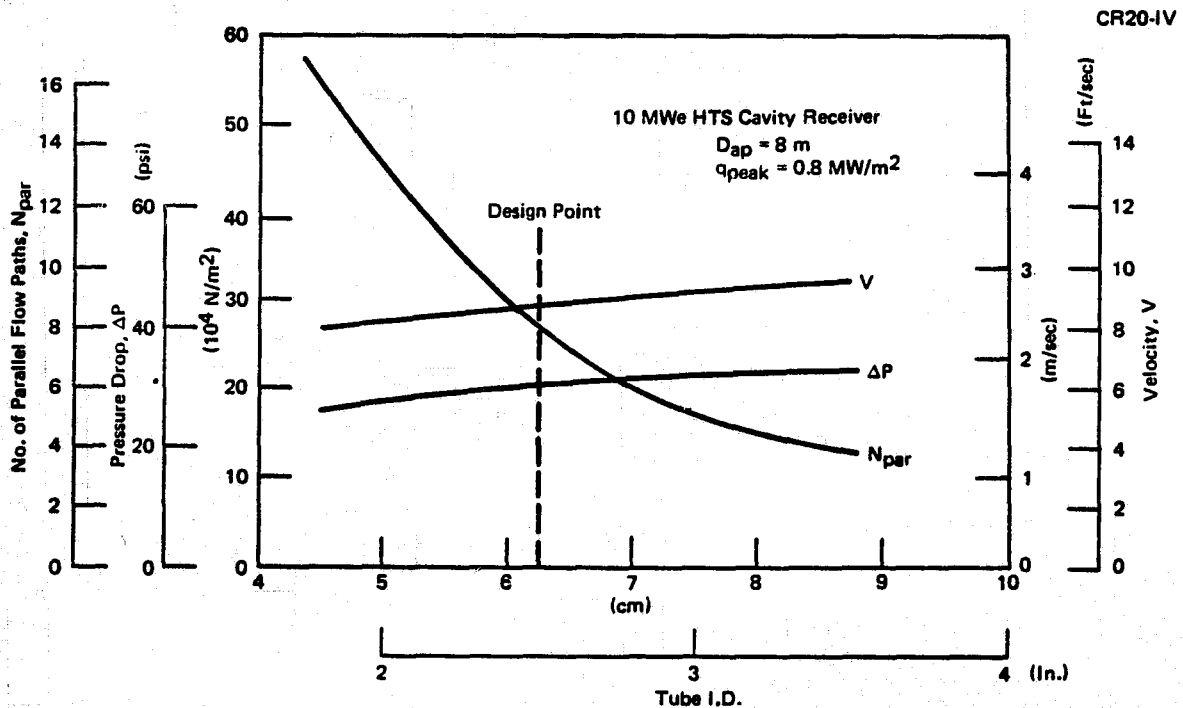

Figure 4-12. Cavity Receiver Coolant Tube Parameters

Table 4-5. Cavity Receiver Design Characteristics

Peak Power, MWt	44.8
Fluid	HTS
Design Flowrate, kg/hr (lb/hr)	371,900 (820,100)
Nominal Inlet Temp, °C (°F)	208 (550)
Nominal Outlet Temp, °C (°F)	566 (1050)
Film Temp, °C (°F)	608 (1125)
Design Pressure Drop, kPa (psi)	250 (36)
Aperture Dia, m (ft)	8.0 (26.2)
Tube I.D., cm (in.)	6.4 (2.50)
Number of Parallel Flow Paths	8

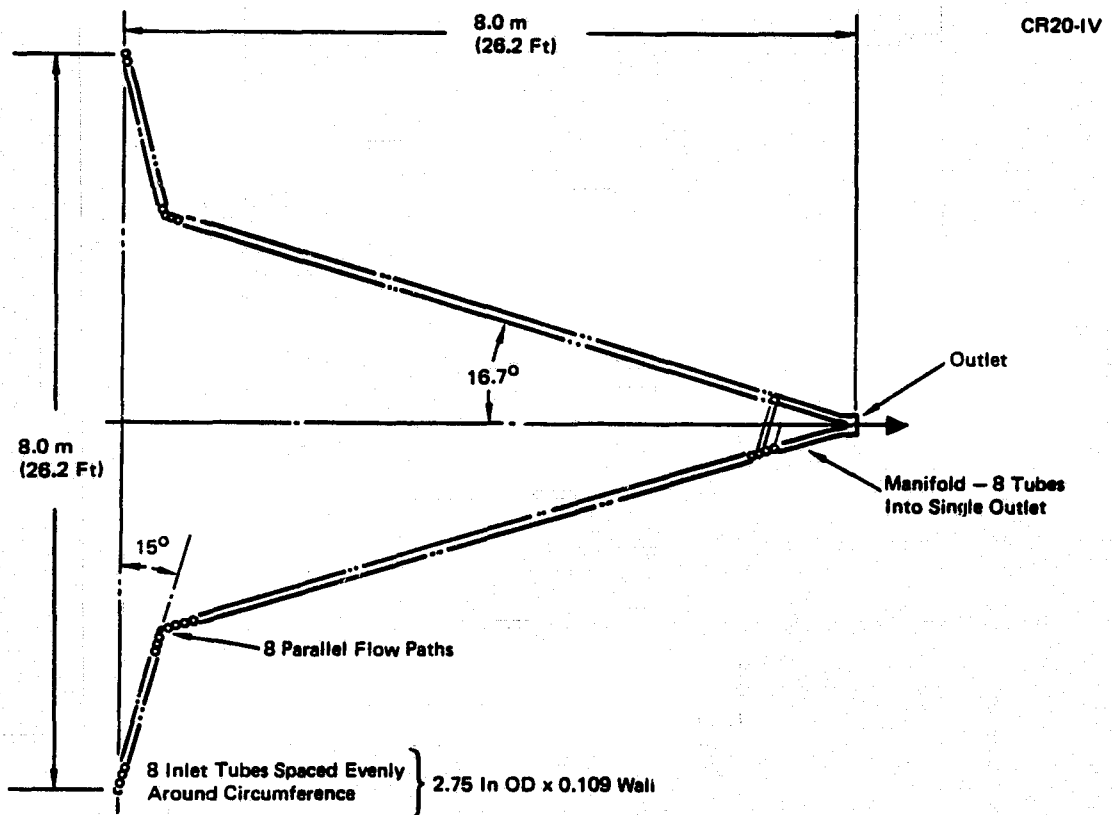

Figure 4-13. Cavity Receiver

Transportation of a fully assembled 8-meter diameter receiver by normal surface means is impractical, if not impossible. Therefore, the absorber would be fabricated in pieces with the final assembly done at the site. The inner cone with a diameter of 4 meters is transportable by truck with special permits. The outer cone would be shop-fabricated in four easily transportable segments and field assembled to the inner cone.

The external cylindrical receiver configuration was determined after analyzing a range of cylindrical heights between 7 and 11 m, diameters of 6 and 7 meters and both single and two-pass flow paths. The single pass configuration, while attractive because of its simplicity, was eliminated from further consideration because of the requirement for very small absorber tube diameters.

The effect of receiver dimensions on receiver weight is shown in Figure 4-14. Smaller receivers are preferred from both thermal loss and weight considera-

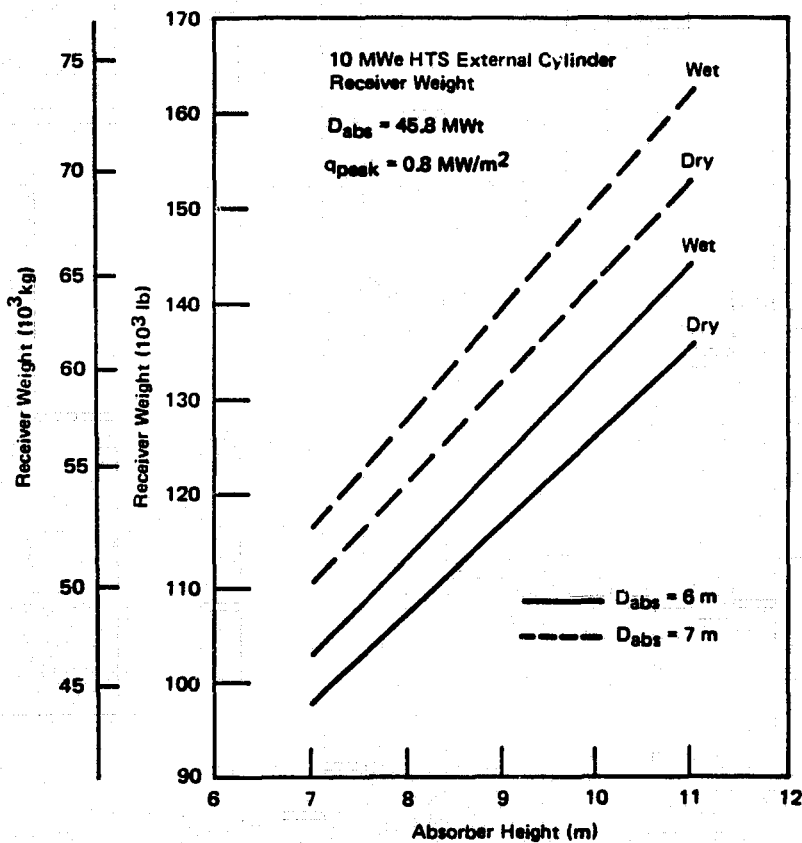

Figure 4-14. External Receiver Weight

tions, however, optical losses limit the receiver diameter to 6 and the height to 9.4 m. Figure 4-15 shows the coolant pressure drop, velocity and number of parallel flow paths for the chosen configuration. Table 4-6 gives the receiver design characteristics.

The receiver design shown in Figure 4-16 employs 24 identical modular assemblies to minimize fabrication, transportation, installation and maintenance costs.

4.1.3 Collector Subsystem – Tower Assembly

The tower subsystem for the 0.5 MWe case is identical to the commercial unit, a guyed steel unit approximately 36 m high. The tower for the 10 MWe case is approximately 90 m high and is a free standing steel design. Selection of the free standing steel tower was based on the results of previous studies which led to selection of a free standing steel tower for the similar receiver height and weight requirements of the 10 MWe pilot plant at Barstow.

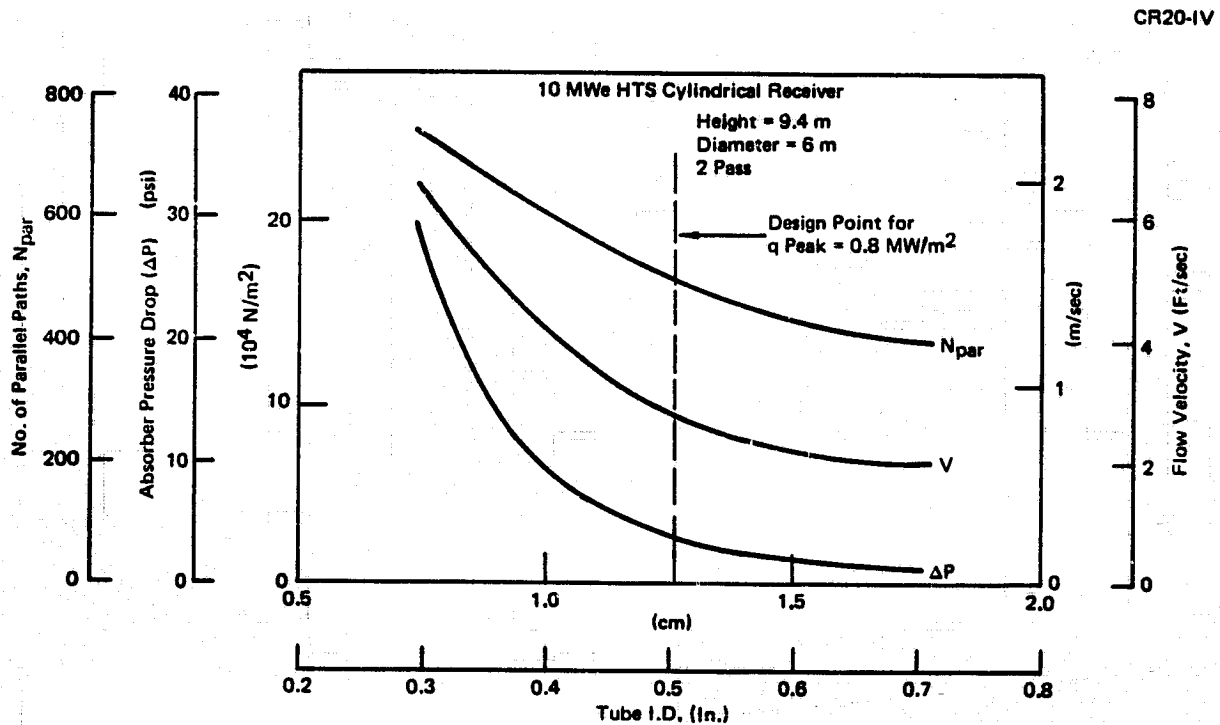

Figure 4-15. External Receiver Coolant Tube Parameters

Table 4-6. External Cylindrical Receiver Design Characteristics

Peak Power, MWt	44.8
Fluid	HTS
Design Flowrate	371,900 (820,100)
Nominal Inlet Temp, °C (°F)	288 (550)
Nominal Outlet Temp, °C (°F)	566 (1050)
Film Temp, °C (°F)	608 (1125)
Design Pressure Drop, kPa (psi)	28. (4.0)
Diameter, m (ft)	6.0 (19.7)
Height, m (ft)	9.4 (31)
Tube I.D., cm (in.)	1.30 (0.51)
No. of Passes Per Flow Path	2
No. of Flow Paths	480
No. of Panels	24
No. of Tubes Per Panel	20

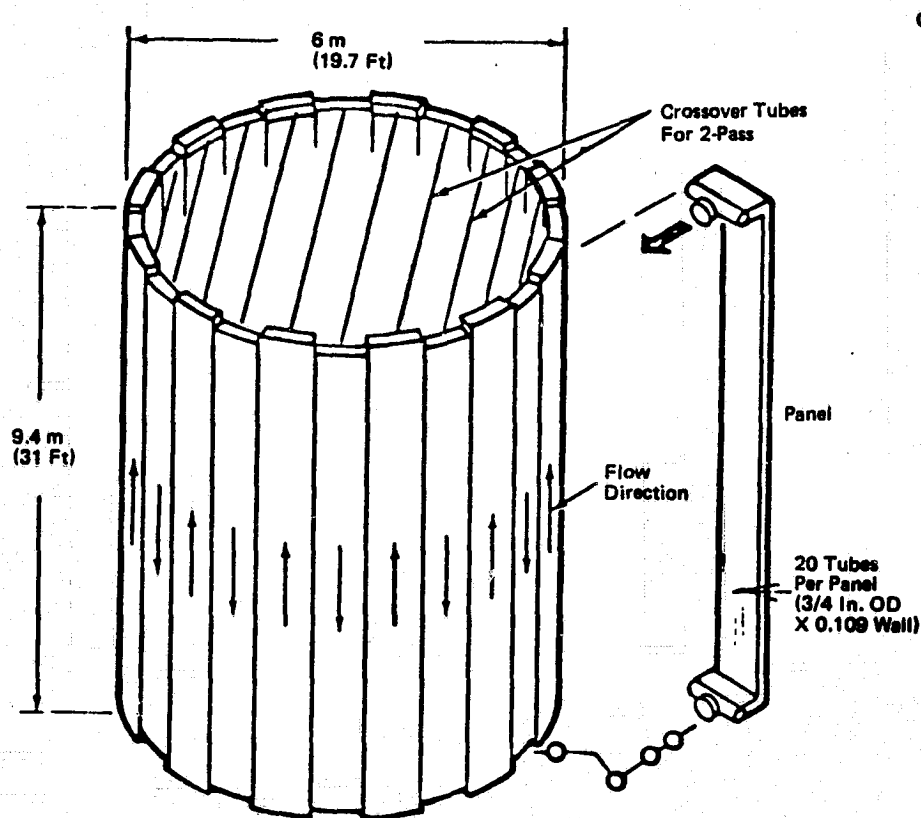

Figure 4-16. External Receiver Configurations

4.1.4 Energy Transport Subsystem

The 0.5 MWe and 10 MWe sensitivity cases utilize an energy transport system that is identical in configuration to the commercial system, the only difference being in the size of pumps and piping. Schematic diagrams of the two subsystems are shown in Figures 4-17 and 4-18.

4.1.5 Energy Storage Subsystem

The energy storage subsystem for the 0.5 MWe and 10 MWe cases is an HTS/taconite thermocline similar to the commercial design, the only difference being the physical size and thermal storage capacity.

4.1.6 Power Conversion Subsystem

The PCS retained the radial outflow turbine for both the 0.5 MWe and 10 MWe cases. Estimates of the turbine efficiency for the two cases came from ETI with the 0.5 MWe turbine having an efficiency of approximately 0.81 and a maximum of three extraction ports and the 10 MWe case an efficiency of 0.85 and 5 extraction ports. With the exception of the number of feedwater heaters and the equipment size, the 0.5 MWe and 10 MWe PCS are nearly identical to the commercial configuration.

Schematic diagrams of the PCS for the two cases are presented in Figures 4-17 and 4-18 with flow rates, pressures, temperatures and power levels.

The Auxiliary Power Requirements of the system variations for the 0.5 MWe and 10 MWe sensitivity cases are presented in Tables 4-7 and 4-8. These power requirements are based on component efficiencies and powers presented in Volume III for design conditions during periods of insolation, no insolation, night standby and emergency shutdown conditions. Where appropriate, the power consumption of cycling units, such as the instrument air dryer, have been averaged over the cycle period. The results of these tabulations have been used to refine the gross electrical power that the turbine should produce to meet the net power requirements and to refine the gross electrical energy to be produced annually to meet the capacity factor requirement.

4.1.7 Plant Control Subsystem

The plant control subsystem for the 0.5 MWe and 10 MWe cases is similar to the commercial design.

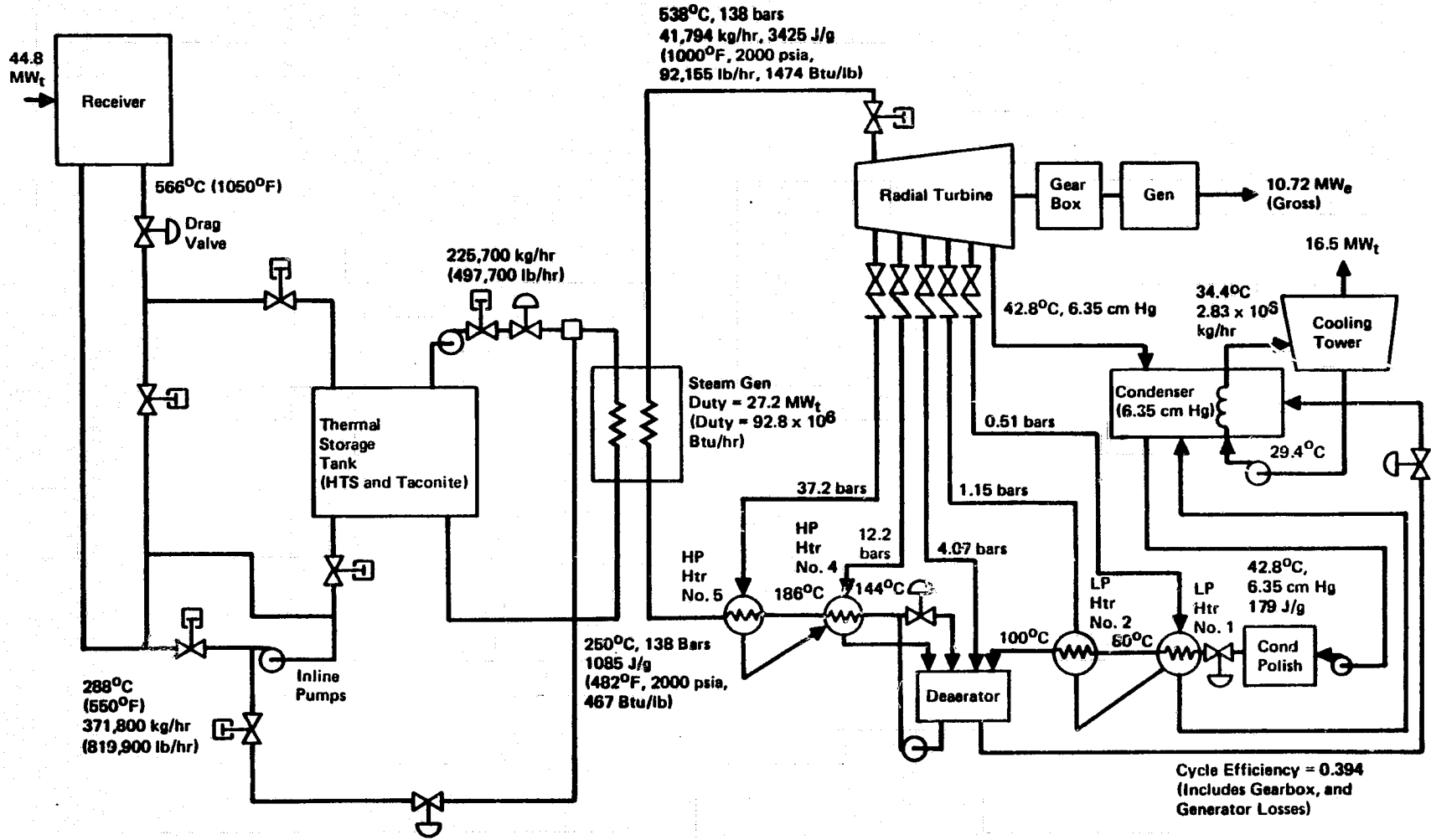

Figure 4-17. System Schematic (10 MW_e , $\text{CF} = 0.4$)

4-20

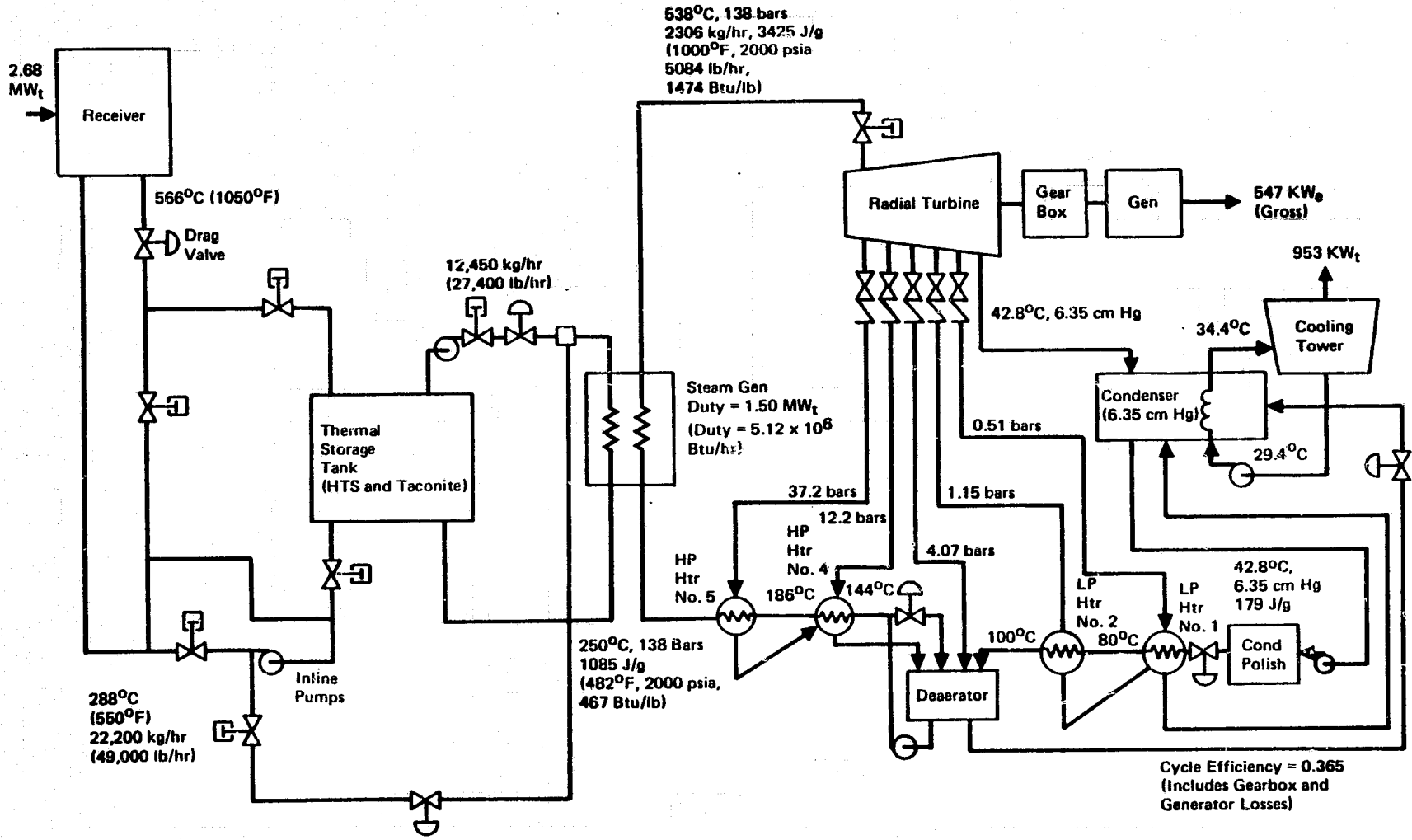

Figure 4-18. System Schematic (0.5 MW_e, CF - 0.4)

Table 4-7. Plant Auxiliary Power Requirements (kW),
0.5 MWe Commercial

Component	Daylight operation (1.0 MWe)	Evening operation (1.0 MWe)	Night standby	Emergency power (AC)
Steam Generator Feed Pump	11.0	11.0	No	No
Condensate Pump	0.6	0.6	No	No
Condenser Exhauster Vacuum Pump	4.0	4.0	No	No
Condensate Transfer Pump	No	No	0.1	No
Plant Air Compressor	1.8*	1.8*	0.3**	No
Circulating Water Pump	4.2	4.2	No	No
Cooling Tower Fan	5	5	No	No
Turbine DC Oil Pump	No	No	No	****
Chemical Pumps	1.9	1.9	No	No
HVAC	3.0 (Estimate)	3.0 (Estimate)	1.0	3.0 (Estimate)
Lighting	2.0	2.0	2.0 (Estimate)	1.0 (Estimate)
UPS	2.0	2.0	2.0	2.8 (Estimate)
Receiver Pump	7	No	No	No
Hot Storage Pump	1.5	1.5	No	No
Heliostats	2.0	No	No	8.4
Trace Heating	No	No	5.0	5.0
Powdex Recirculating Pump	No	No	NEG	NEG
Plant Air Dryer	0.7***	0.7***	0.7***	No
Transformer and Transmission Loss	0.5	0.5	NEG	NEG
TOTAL	47.2	38.2	11.1	20.2

*Estimated average power requirement during operation-maximum requirement.

**Estimate average power requirement during standby-maximum requirement.

***Average requirement based on one regeneration per 4 hours - requirement is 2.8 kW for 1-1/2 hours.

****Estimated average power requirement during 14 hour standby.

Table 4-8. Plant Auxiliary Power Requirements (kW),
10 MW Commercial

Component	Daylight operation (1.0 MWe)	Evening operation (1.0 MWe)	Night standby	Emergency power (AC)
Steam Generator Feed Pump	270	270	No	No
Condensate Pump	10	10	No	No
Condenser Exhauster Vacuum Pump	23	23	No	No
Condensate Transfer Pump	No	No	1.0	No
Plant Air Compressor	10*	10*	2**	No
Circulating Water Pump	80	80	No	No
Cooling Tower Fan	100	100	No	No
Turbine DC Oil Pump	No	No	No	NEG
Chemical Pumps	6	6	No	No
HVAC	11.3 (Estimate)	11.3 (Estimate)	3.0	11.3 (Estimate)
Lighting	4.0	4.0	3.0 (Estimate)	2.0 (Estimate)
UPS	7.5	7.5	7.5	8.3 (Estimate)
Receiver Pump	130	No	No	No
Hot Storage Pump	30	30	No	No
Heliostats	40	No	No	166
Trace Heating	No	No	43.0	43.0
Powdex Recirculating Pump	No	No	NEG	NEG
Plant Air Dryer	0.7***	0.7***	0.7***	No
Transformer and Transmission Loss	10	10	NEG	NEG
TOTAL	721	551	60.2	230.6

*Estimated average power requirement during operation-maximum requirement
11.9 kW.

**Estimated average power requirement during standby-maximum requirement
11.9 kW.

***Average requirement based on one regeneration per 4 hours - requirement is
1.8 kW for 1-1/2 hours.

****Estimated average power requirement during 14 hour standby.

4.2 COST IMPACT OF POWER RATING VARIATIONS

Figure 4-19 shows the relative cost impact of variation in rated power.

This figure is based on the Investment and O&M cost projections shown in Tables 4-9 and 4-10 for plants rated at 0.5 and 10 MWe along with the 1.0 MWe baseline costs described in Section 3.10. Table 4-1 summarizes the technical characteristics that have been costed. The associated energy costs may be summarized by production rate, as follows:

Power Rating	<u>Mils/KWH Per Annual Installation Rate (MWe)</u>			
	<u>100</u>	<u>500</u>	<u>1000</u>	<u>5000</u>
0.5 MWe	242	234	230	220
1.0 MWe	169	165	161	156
10.0 MWe	117	110	108	103

These results have been determined using the groundrules, assumptions and costing approach as described in Section 3.10. However, in addition to the use of the 6.5-year program baseline, the 10 MWe projections have been compared to adjusted Preliminary Design Report (PDR) costing results for the Barstow Pilot Plant in order to assure relative compatibility.

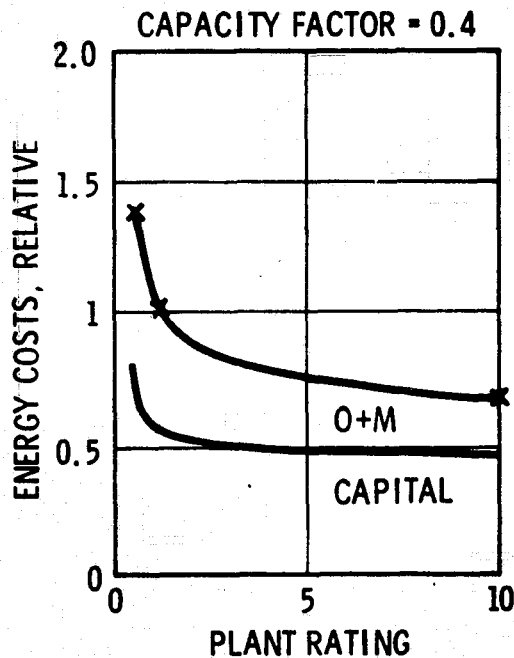

Figure 4-19. Sensitivity Results

Table 4-9. 0.5 MWe Commercial System Costs
0.4 Capacity Factor - 1978 Dollars

Cost Element	Total Cost at Production Rate (\$ x 10 ³)			
	200/Yr	1,000/Yr	2,000/Yr	10,000/Yr
Collector	\$ 532	\$ 481	\$ 463	\$ 424
Power Conversion	512	478	462	389
Energy Transport	69	63	61	55
Energy Storage	99	90	87	82
Control	205	194	190	181
Other*	344	344	344	344
Total Investment	\$1,761	\$1,650	\$1,607	\$1,475
Annual O&M				
Materials and Nonlabor	\$ 13	\$ 13	\$ 13	\$ 13
Maintenance Labor	36	36	36	36
Manager/Operator	28	28	28	28
Total O&M	\$ 77	\$ 77	\$ 77	\$ 77
Energy Cost (Mills/KWH)	242	234	230	220

*Special Features, Construction Manager, Miscellaneous Equipment etc.

Table 4-10. 10 MWe Commercial System Costs
0.4 Capacity Factor - 1978 Dollars

Cost Element	Total Cost at Production Rate (\$ x 10 ³)			
	10/Yr	50/Yr	100/Yr	500/Yr
Collector	\$ 8,484	\$ 7,243	\$ 6,988	\$ 6,203
Power Conversion	6,048	5,633	5,472	5,120
Energy Transport	840	764	734	667
Energy Storage	801	758	740	704
Control	263	248	243	230
Other*	4,227	4,227	4,227	4,227
Total Investment	\$20,663	\$18,873	\$18,404	\$17,151
Annual O&M				
Materials and Nonlabor	\$ 200	\$ 200	\$ 200	\$ 200
Maintenance, Labor				
Manager/Operator	340	340	340	340
Total O&M	\$ 540	\$ 540	\$ 540	\$ 540
Energy Cost Mills/KWH)	117	110	108	103

*Special Features, Construction Manager, Miscellaneous Equipment, etc.

Section 5 SENSITIVITY TO CAPACITY FACTOR CHANGES

The sensitivity of the commercial system design, performance and cost of energy of the commercial system to changes in storage capacity was evaluated by altering the concentrator/receiver/storage subsystems. A "no storage" case with a capacity factor of 0.275 and an increased storage case with a capacity factor of 0.7 were evaluated. Both cases retained the 1.0 MWe power conversion subsystem of the commercial system. The modifications to the system were accomplished by a combination of detailed analysis and trade studies on items of major importance and a parametric scale-up or scale-down of items which are of secondary importance. Those items which were treated by detailed analysis or trade studies are:

- Concentrator field/tower height/aperture size optimization
- Energy storage sizing and design
- Parasitic power requirements

Those items treated parametrically with scaling factors are:

- Pipe sizing
- Controls/Instrumentation
- Energy transport/storage thermal losses
- Pump power

5.1 DESIGN AND PERFORMANCE IMPACT

A brief discussion of the results of the design analysis and trade studies on the items listed above and a description of the design and performance modifications in each of the subsystems are given below.

5.1.1 Collector Subsystem — Concentrator Assembly

The concentrator used in the two sensitivity cases is identical to that of the commercial system. Both cases utilize a north field with the only difference being the number of heliostats which is given in Table 5-1.

Table 5-1. Capacity Factor Sensitivity Design Summary

Net Power Output, MWe	1.0	1.0	1.0
Capacity Factor	0.275	0.40	0.70
Cycle Efficiency	0.370*	0.388	0.388
Thermal Storage Capacity, MWh	0.5 (10 minute buffer)	11.9	36.6
Receiver, Design Power, MWt	2.93	4.72	8.01
Receiver Aperture Diameter, m	3.5	3.5	4.5
Optical Height, m	34	34	38
No. of Heliostats	110	133	227

*Derated for off-design performance

The concentrator field for the 0.7 capacity factor case was selected from the results of the concentrator field optimization presented in Section 4.1. The concentrator field for the "no storage" case is capable of producing more than design power at certain times during which some heliostats must be defocused. This approach was determined to be cost effective by the following trade study.

5.1.2 Concentrator Field Optimization - No Storage Case

The optimization of the concentrator field for the case of supplying 1.0 MWe with no storage must be treated in a manner somewhat differently than the other cases. Since the capacity factor was not specified for the no storage case, it was considered a variable to be optimized. This was accomplished by first sizing the field to produce sufficient thermal energy at equinox noon to result in 1.0 MWe net energy. The field size was then increased in increments to provide more than the required energy at certain times. This excess energy would be spilled by defocussing some heliostats at these times. A plot of the percentage of time a given insolation level is available is presented in Figure 5-1. The shaded area represents the energy lost by defocussing at insolation levels of 750 W/m^2 or greater. This design insolation level was

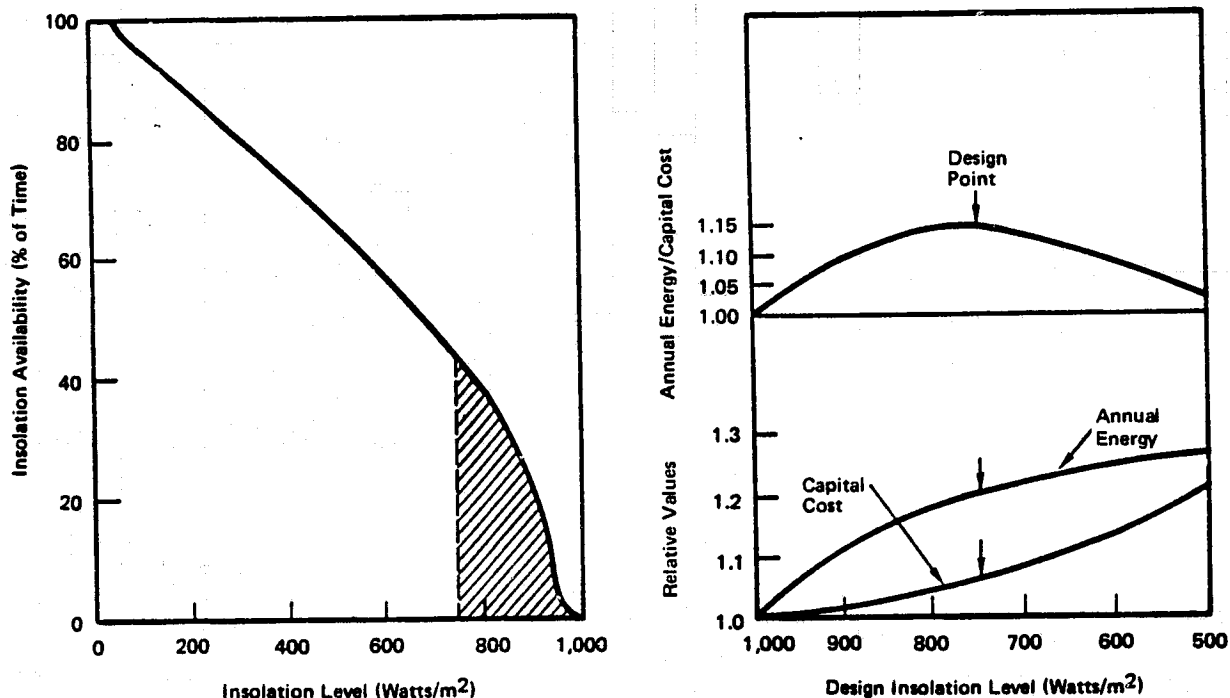

Figure 5-1. Concentrator Field Optimization – No Storage

selected by comparing the increase in annual energy production to the increase in total plant capital cost (see Figure 5-1.) The peak annual energy/capital cost ratio occurs for a concentrator field which produces 1.0 MWe net electrical energy at insolation levels of 750 W/m^2 . The resultant capacity factor is 0.275, or 2400 MWh per year.

Receiver Subsystem

The receiver for the "no storage" case has a 3.5 m diameter aperture and is 4.0 m deep, identical to the commercial system. The receiver for the 0.7 capacity factor case has a 4.5 m diameter aperture and is 4.5 m deep based on the collector field optimization results presented in Section 4.1.1.

Tower Subsystem

The tower subsystem for the "no storage" case remains the same as the commercial unit, a guyed steel tower approximately 36 m high. The tower for the 0.7 capacity factor case is also a guyed tower approximately 40 m high as determined by the concentrator field optimization results.

Energy Transport Subsystem

The 0.7 capacity factor system utilizes an energy transport system that is identical in configuration to the commercial system, the only difference being slightly larger pumps and lines to accommodate the higher mass flow rates. The "no storage" case utilizes a two tank storage subsystem to provide 10 minutes of buffer storage and hence an energy transport subsystem similar to that of the 3.5 year and 4.5 year programs is required. Schematic diagrams of the two energy transport systems are shown in Figures 5-2 and 5-3.

Energy Storage Subsystem

The energy storage subsystem for the 0.7 capacity factor case is an HTS/taconite thermocline similar to and larger than the commercial storage tank. The "no storage" case utilizes a two tank system, one for hot storage and the other for cold storage, to provide sufficient storage for 10 minutes of full-load operation. This eliminates the need for transient operation of the power conversion subsystem during brief insolation outages such as caused by clouds.

Power Conversion Subsystem

The power conversion subsystem is unchanged for the two capacity factor sensitivity cases, power output remaining at 1.0 MWe.

The auxiliary power requirements of the system variations for the "no storage" and 0.7 capacity factor cases are presented in Tables 5-2 and 5-3. These power requirements are based on component efficiencies and powers presented in Volume III for design conditions during periods of insolation, no insolation, night standby and emergency shutdown conditions. Where appropriate, the power consumption of cycling units such as the instrument air dryer have been averaged over the cycle period. The results of these tabulations have been used to refine the gross electrical power that the turbine should produce to meet the net power requirements and to refine the gross electrical energy to be produced annually to meet the capacity factor requirement.

Plant Control Subsystem

The plant control subsystem is unchanged for the two capacity factor sensitivity cases.

MCDONNELL DOUGLAS

5-5

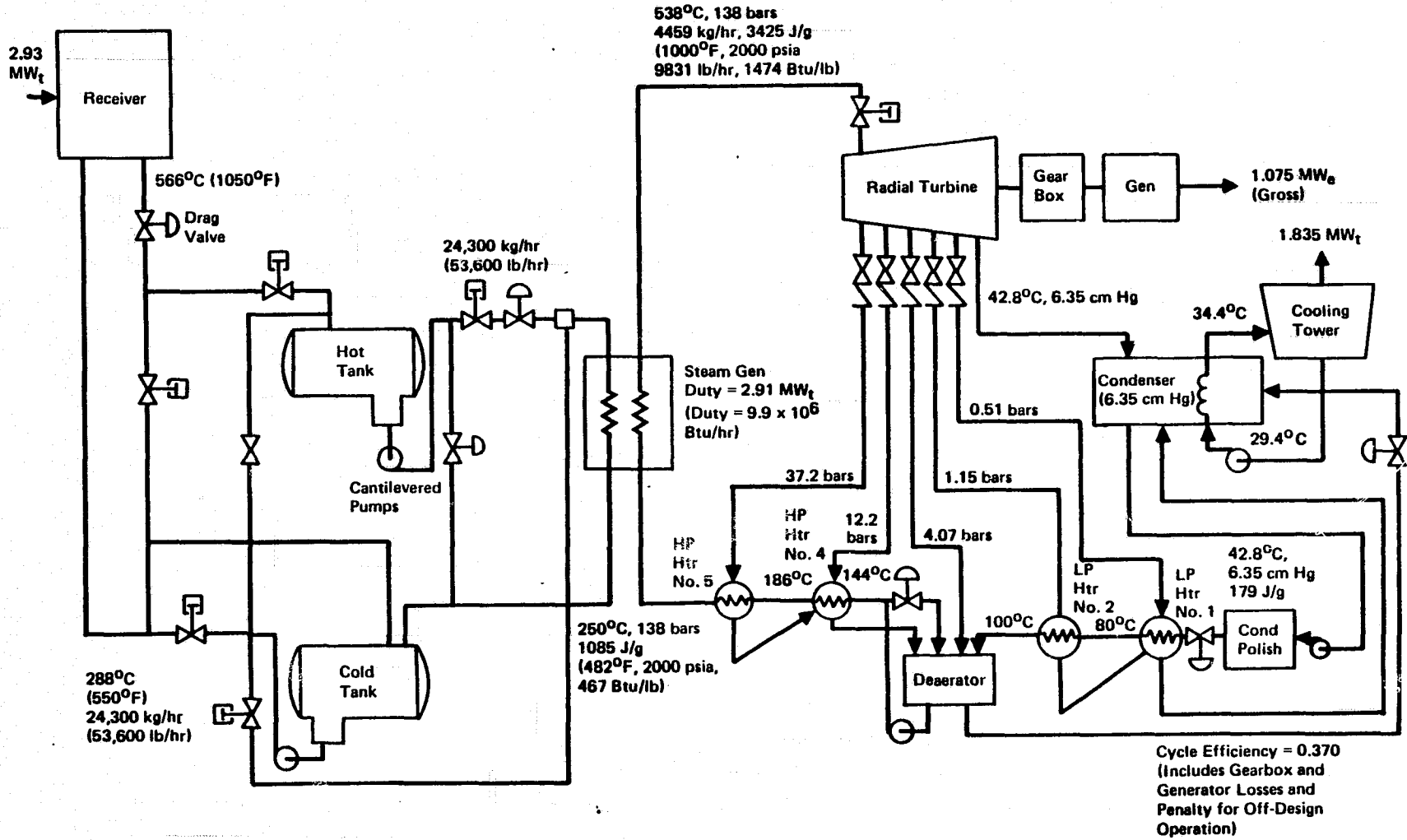

Figure 5-2. System Schematic (1 Mw_e , $\text{CF} = 0.275$)

MCDONNELL DOUGLAS

56

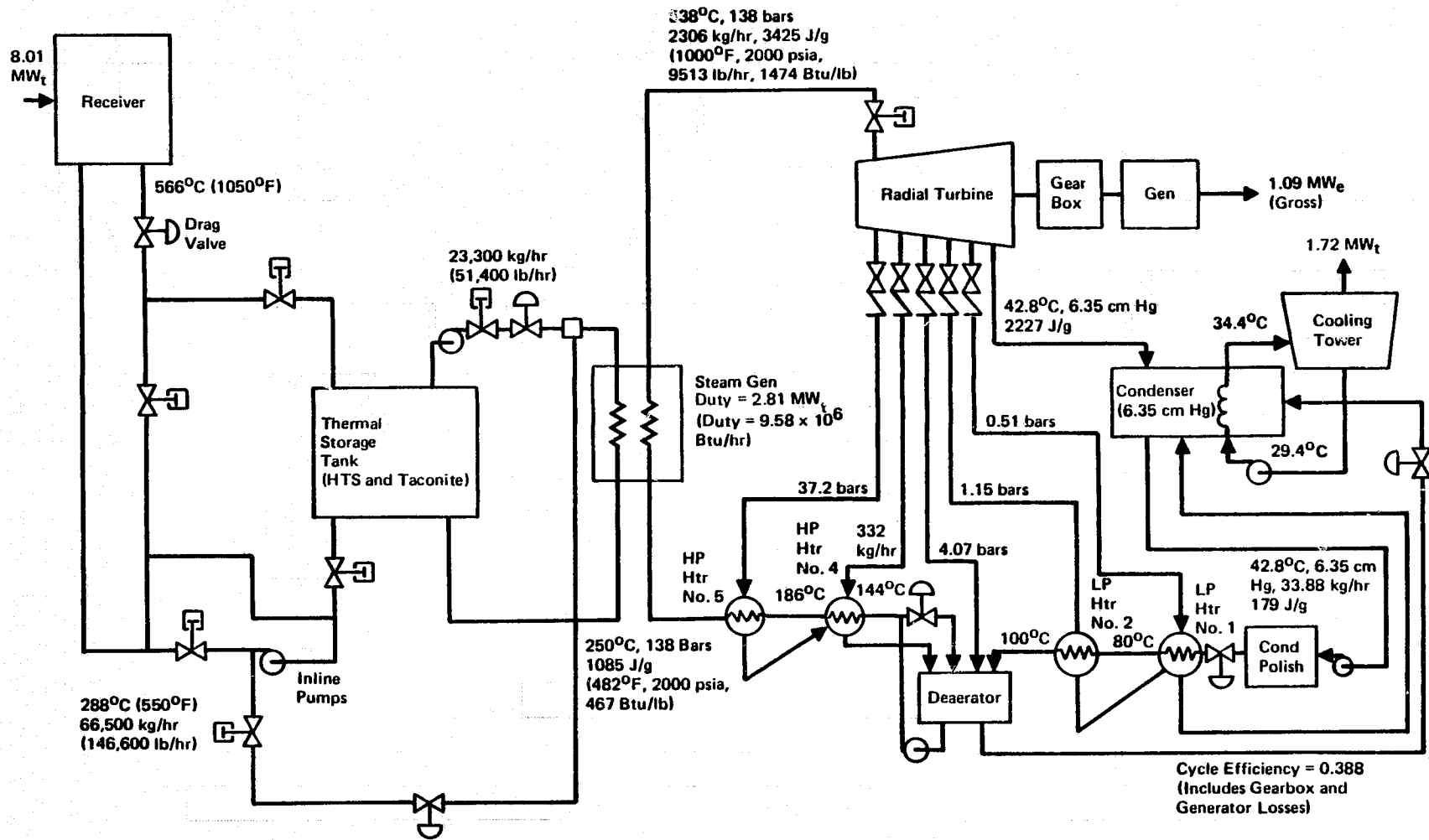

Figure 5-3. System Schematic (1 MW_e , $\text{CF} = 0.7$)

Table 5-2. Plant Auxiliary Power Requirements (kW),
Commercial, 1 MW, CF = 0.7

Component	Daylight operation (1.0 MWe)	Evening operation (1.0 MWe)	Night standby	Emergency power (AC)
Steam Generator Feed Pump	20.3 kw	20.3 kw	No	No
Condensate Pump	1.0	2.0	No	No
Condenser Exhauster Vacuum Pump	6.0	6.0	No	No
Condensate Transfer Pump	No	No	0.1	No
Plant Air Compressor	2.8*	2.8*	0.5**	No
Circulating Water Pump	8.4	8.4	No	No
Cooling Tower Fan (Avg.)	10	10	No	No
Turbine DC Oil Pump	No	No	No	NEG
Chemical Pumps	1.9	1.9	No	No
HVAC	3.0 (Estimate)	3.0 (Estimate)	1.0	3.0 (Estimate)
Lighting	2.0	2.0	2.0 (Estimate)	1.0 (Estimate)
UPS	2.0	2.0	2.0	2.8 (Estimate)
Receiver	23	No	No	No
Hot Storage Pump	3	3	No	No
Heliostats	4.0	No	No	16.6
Trace Heating	No	No	6.8****	6.8****
Powdex Recirculating Pump	No	No	NEG	NEG
Plant Air Dryer	0.7***	0.7***	0.7***	No
Transformer and Transmission Loss	1	1	NEG	NEG
TOTAL	89.1	62.1	13.1	30.2

*Estimated average power requirement during operation-maximum requirement 11.9 kW.

**Estimated average power requirement during standby-maximum requirement 11.9 kW.

***Average requirement based on one regeneration per 4 hours - requirement is 1.8 kW for 1-1/2 hours.

****Estimated average power during 14 hour standby.

Table 5-3. Plant Auxiliary Power Requirements (kW),
Commercial, 1 MW, CF = 0.275

Component	Daylight operation (1.0 MWe)	Night standby	Emergency power (AC)
Steam Generator Feed Pump	20.3	No	No
Condensate Pump	1.0	No	No
Condenser Exhauster Vacuum Pump	6.0	No	No
Condensate Transfer Pump	No	0.1	No
Plant Air Compressor	2.8*	0.5**	No
Circulating Water Pump	8.4	No	No
Cooling Tower Fan (Avg)	10	No	No
Turbine DC Oil Pump	No	No	NEG
Chemical Pumps	1.9	No	No
HVAC	5.0 (Estimate)	1.0	5.0 (Estimate)
Lighting	3.0	2.0 (Estimate)	1.0 (Estimate)
UPS	2.0	2.0	2.8 (Estimate)
Receiver Pump	8.5	No	No
Hot Storage Pump		No	No
Heliostats	4.0	No	16.6
Trace Heating	No	6.8	6.8
Powdex Recirculating Pump	No	NEG	NEG
Plant Air Dryer	0.7***	0.7***	No
Transformer and Transmission Loss	1	NEG	NEG
TOTAL	74.6	13.1	32.2

*Estimated average power requirement during operation-maximum requirement
11.9 kW.

**Estimated average power requirement during standby-maximum requirement
11.9 kW.

***Average requirement based on one regeneration per 4 hours - requirement is
1.8 kW for 1-1/2 hours.

****Estimated average power during 14 hour standby.

5.2 COST IMPACT OF CAPACITY FACTOR VARIATIONS

Figure 5-4 shows the relative cost impact of variation in capacity factor.

This figure is based on the Investment and O&M cost projections shown in Tables 5-4 and 5-5 for plants rated at 0.28 and 0.7 capacity, along with the 1.0 MWe baseline costs described in Section 3.10 for a 0.4 capacity factor. Table 5-1 summarizes the technical characteristics that have been costed. The associated energy costs may be summarized by production rates for a 1 MWe plant, as follows:

Capacity Factor	<u>Mils/KWH Per Annual Installation Rate (MWe)</u>			
	<u>100</u>	<u>500</u>	<u>1000</u>	<u>5000</u>
0.28	221	214	211	204
0.40	169	165	161	156
0.70	129	125	122	118

These results have been determined using the groundrules, assumptions and costing approach as described in Section 3.10, Capital costs.

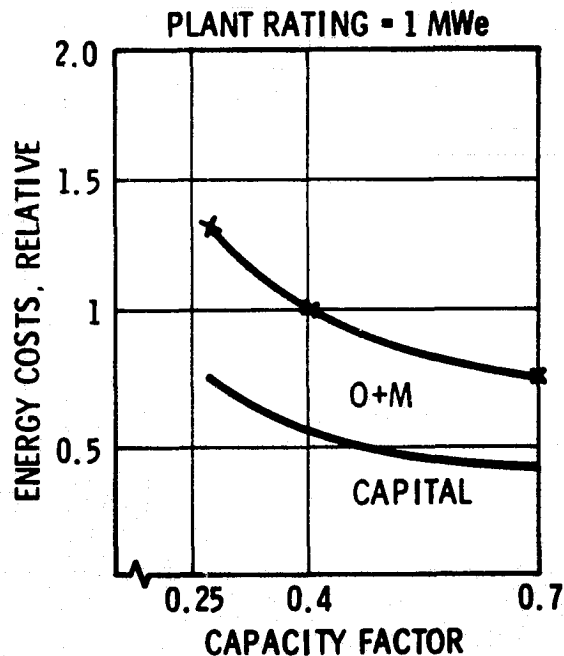

Figure 5-4. Sensitivity Results

Table 5-4. 1 MWe Commercial System Costs
0.7 Capacity Factor - 1978 Dollars

Cost Element	Total Cost at Production Rate (\$ x 10 ³)			
	100/Yr	500/Yr	1000/Yr	5000/Yr
Collector	\$1,209	\$1,114	\$1,042	\$ 981
Power Conversion	843	781	756	635
Energy Transport	125	113	109	100
Energy Storage	331	311	302	286
Control	205	194	190	181
Other*	549	549	549	549
Total Investment	\$3,262	\$3,062	\$2,948	\$2,732
Annual O&M				
Materials and Nonlabor	\$ 31	\$ 31	\$ 31	\$ 31
Maintenance Labor	87	87	87	87
Manager/Operator	28	28	28	28
Total O&M	\$ 146	\$ 146	\$ 146	\$ 146
Energy Cost (M/KWH)	129	125	122	118

*Special Features, Construction Manager, Miscellaneous Equipment, etc.

Table 5-5. 1 MWe Commercial System Costs
0.28 Capacity Factor - 1978 Dollars

Cost Element	Total Cost at Production Rate (\$ x 10 ³)			
	100/Yr	500/Yr	1000/Yr	5000/Yr
Collector	\$ 686	\$ 642	\$ 613	\$ 557
Power Conversion	843	781	756	702
Energy Transport	67	61	59	54
Energy Storage	46	42	40	38
Control	205	194	190	181
Other*	419	419	419	419
Total Investment	<u>\$2,266</u>	<u>\$2,139</u>	<u>\$2,077</u>	<u>\$1,951</u>
Annual O&M				
Material and Nonlabor	\$ 17	\$ 17	\$ 17	\$ 17
Maintenance Labor	49	49	49	49
Manager/Operator	28	28	28	28
Total O&M	<u>\$ 94</u>	<u>\$ 94</u>	<u>\$ 94</u>	<u>\$ 94</u>
Energy Cost (Mills/KWH)	221	214	211	204

*Special Features, Construction Manager, Miscellaneous Equipment, etc.