

THE USE OF CONICAL AND CYLINDRICAL FIELDS IN
SUPERSONIC WING THEORY

By Robert T. Jones

Ames Aeronautical Laboratory

Some of the recent advances in the theory of thin airfoils are presented with particular reference to extensions of the theory to three-dimensional flows and to supersonic speeds.

The thin-airfoil theory is essentially a linearized theory of small disturbances and the origin of the concepts may be traced back to the older theories of Munk and Ackeret. The present emphasis on three-dimensional flows arose from the discovery that the type of two-dimensional supersonic flow considered by Ackeret is aerodynamically inefficient. The search for aerodynamically efficient forms for supersonic flight also focuses attention on the linear, or small-disturbance, theory since bodies and wings creating large disturbances are thought to be aerodynamically inefficient.

The newer development of the theory is the work of many investigators. The present discussion, however, is based largely on the conical-flow theory first employed by Busemann (reference 1).

The term "thin airfoil" is used to denote a thin, essentially flat body, the surface of which departs only slightly from the xy -plane. In the general problem no restriction is made on the shape of the plan form, but it is essential that the body be thin and flat in all vertical cross sections; hence, slender bodies of revolution are avoided.

The problem discussed herein is the calculation of the small disturbance velocities u , v , and w in the external field produced by the flight velocity V of the airfoil.

As is well known in acoustics, air motions of small amplitude are governed primarily by the simple properties of elasticity of volume and density. In order to depict such motions mathematically, a frictionless, perfectly elastic fluid is, therefore, adopted and a velocity field uvw must be found which is consistent with Newton's laws and which agrees at the airfoil surface with the outward, or normal, velocity imparted by the motion of the airfoil. The application of Newton's laws to the motions of small elements of such a simplified model fluid results in the familiar wave equation for the velocity potential ϕ ,

$$\phi_{xx} + \phi_{yy} + \phi_{zz} = \frac{1}{c^2} \phi_{tt} \quad (1)$$

where c is the velocity of sound and $\phi_x = u$, $\phi_y = v$, $\phi_z = w$.

The description of the whole velocity field by a single scalar potential ϕ is, of course, a great simplification and, as explained in text books on hydrodynamics, this scalar potential occurs in every case of frictionless motion in which the density ρ is a function of the pressure only. The elements of such a fluid move only under the action of "buoyancy" or pressure forces. When the density is dependent on the pressure only, variations of density occur only along the direction of the buoyant force. This force then passes through the center of gravity of each element and no rotation is produced. The existence of ϕ follows from the absence of rotation.

Of first interest in the airfoil problem are steady flows. The steady flow consists of a fixed pattern of streamlines attached to the airfoil and moving with it. In order to represent the steady flow, it will be necessary to transform the stationary axes of equation (1) to axes moving with the airfoil at the flight velocity V . The quantity $\frac{1}{c^2} \phi_{tt}$ is then replaced by $\frac{V^2}{c^2} \phi_{xx}$ and the equation becomes, after transposition,

$$\left(1 - \frac{V^2}{c^2}\right) \phi_{xx} + \phi_{yy} + \phi_{zz} = 0 \quad (2)$$

in which $\frac{V}{c}$ is the Mach number M . The problem is now the mathematical one of finding a solution of equation (2) which agrees with the normal boundary velocity imparted by the airfoil. When the thin airfoil as specified is used, it is found sufficient to replace the actual boundary condition by an equivalent condition on the vertical velocity w in the chord plane; that is,

$$(w)_{z=0} = V \frac{dz}{dx}$$

where $\frac{dz}{dx}$ is the slope of the airfoil surface. It is important to note that the sliding component of the airfoil surface imparts no motion to the fluid since the fluid is frictionless. The error made in the equivalent boundary condition at $z = 0$ becomes appreciable only at distances of the order of one wing thickness from the edge. The pressure distribution over the airfoil surface may likewise be taken as the pressure in the chord plane and is obtained from the well-known formula for the pressure in a sound wave

$$\Delta p = -\rho \frac{\partial \phi}{\partial t}$$

or, in steady flow

$$\Delta p = -\rho v \frac{\partial \phi}{\partial x}$$

from which

$$\frac{\Delta p}{q} = -\frac{2u}{V}$$

Thus far, nothing has been said about subsonic- or supersonic-flight velocities. This distinction arises in equation (2) and in the form of its solutions when $M \gtrsim 1$.

Except for this distinction, variations of M are of no consequence mathematically since they can be represented by an equivalent change in the scale of x relative to the other coordinates. This change of scale is known as the Prandtl-Glauert transformation and is given as

$$x' = \frac{x}{\sqrt{1 - M^2}}$$

or

$$x' = \frac{x}{\sqrt{M^2 - 1}}$$

The formula to be used depends on whether the flight velocity is subsonic or supersonic. In the latter case, the significance of the transformation is easily seen, since this transformation serves to maintain the correct inclination of the Mach waves to the line of flight at different speeds. It should be noted that the sudden transition of the differential equation from the elliptic to the hyperbolic type at $M = 1.0$ is a feature of the steady-flow equation (equation (2)) and does not, of course, arise in connection with equation (1).

The essential features of the steady flow at subsonic or supersonic speeds can then be ascertained from solutions of the reduced or normalized equations. For $M = 0$,

$$\phi_{xx} + \phi_{yy} + \phi_{zz} = 0 \quad (3)$$

and for $M = 1.41$,

$$\Phi_{xx} - \Phi_{yy} - \Phi_{zz} = 0 \quad (4)$$

As may be shown by direct differentiation, equations (3) and (4) possess the primary solutions

$$\phi = f(\alpha x + \beta y + \gamma z)$$

where α , β , and γ are quantities determined so that for equation (3)

$$\alpha^2 + \beta^2 + \gamma^2 = 0$$

and so that for equation (4)

$$\alpha^2 - \beta^2 - \gamma^2 = 0$$

The cylindrical flow field, which is the basis of the two-dimensional or wing section theory, is obtained by specializing the primary solution to the two coordinates x and z . In this case for equation (3) $\alpha = 1.0$ and $\gamma = i$; and for equation (4) $\alpha = 1.0$ and $\gamma = 1.0$ so that the general solutions for the cylindrical or two-dimensional flow field become

$$\phi = f(x \pm iz)$$

or

$$u = f'(x \pm iz)$$

$$w = \pm iu$$

The general solution is the basis of the Munk theory, as well as the more exact wing section analyses which depend on the theory of functions of a complex variable. At supersonic speeds the corresponding solutions are

$$\phi = f(x \pm z)$$

or

$$u = f'(x \pm z)$$

$$w = \pm u$$

This latter form of solution, which represents a plane sound wave of arbitrary intensity at 45° to the normalized coordinate axes, is the basis of the Ackeret theory.

The general form of flow field given by solutions of the two foregoing types is illustrated in figure 1. The sketch on the left-hand side is the familiar subsonic streamline pattern for a symmetrical biconvex wing section. In the subsonic pattern the velocity and pressure disturbances diminish uniformly with distance and in the case of steady flow the field possesses a fore and aft symmetry which results in no pressure drag or wave drag. The sketch on the right-hand side (fig. 1) illustrates the marked difference in streamline pattern that arises when the crosswise velocity of the cylindrical field is supersonic. In this case the phase relation of u and w is shifted (from 1 to i) and the pressure distribution is antisymmetric, resulting in a wave drag. This drag appears as the energy in the plane sound waves emanating from the airfoil. The change from subsonic to supersonic type of flow field arises when the rate of progress of the flow pattern through the still fluid exceeds the velocity of sound. With cylindrical flow, the field is not affected by an axial velocity of the cylinder and the pattern progresses at a rate determined only by the crosswise motion of the cylinder. Hence, the subsonic type of flow may persist on a yawed wing even though the flight velocity is supersonic. (See reference 2.)

The sketch in the lower part of figure 1 represents a cross section of a conical flow field of the type originated by Busemann. The particular case used for illustration herein is the flow produced by a flat plate of triangular plan form moving point foremost at a small angle of attack (fig. 2). The Mach cone originates, of course, at the apex of the triangle and the field inside this cone is geometrically the same in all downstream cross sections except for an expansion in scale along the x -axis. The conical flow field may be obtained by the superposition of primary solutions of the form

$$u = F(\alpha x + \beta y + \gamma z)$$

If $\mu = e^{i\theta}$, then the solution

$$u = F[-2\mu x + (1 + \mu^2)y + i(1 - \mu^2)z]$$

represents a plane sound wave at an angle θ to the y -, z -axes. Superposition of such waves of strength $f'(\mu)$ from $\theta = 0$ to $\theta = 2\pi$ results in a solution analogous to Whittaker's solution; that is,

$$u = \oint f'(\mu) F[-2\mu x + (1 + \mu^2)y + i(1 - \mu^2)z] d\mu$$

The quantity $-2\mu x + (1 + \mu^2)y + i(1 - \mu^2)z$ may be factored into $(\mu - \epsilon) \left(\mu - \frac{1}{\epsilon}\right) (y - iz)$ where

$$\epsilon = \frac{y + iz}{x + \sqrt{x^2 - y^2 - z^2}}$$

The general solution for O^0 is obtained when F is replaced by \log ; that is,

$$\begin{aligned} u &= \oint f'(\mu) \log \left[(\mu - \epsilon) \left(\mu - \frac{1}{\epsilon}\right) (y - iz) \right] d\mu \\ &= \oint f'(\mu) \left[\frac{1}{\mu - \epsilon} + \frac{1}{\mu - \frac{1}{\epsilon}} \right] d\mu \\ &= 2\pi i [f(\epsilon)] \end{aligned}$$

if the contour does not include $\frac{1}{\epsilon}$ and if $\oint f(\mu) d\mu = 0$ or, in other words, if f is an analytic function (see reference 3).

If the flight velocity is subsonic, the argument ϵ is replaced by $\frac{y + iz}{x + \sqrt{x^2 + y^2 + z^2}}$. The latter solution was given by W. F. Donkin in 1857

(see reference 4). In either case the form of the argument shows an essential similarity to an expanding cylindrical field (see reference 5).

In fact, for the slender conical field, where $y^2 + z^2$ may be neglected

in comparison with x^2 , the argument becomes simply $\frac{y + iz}{2x}$.

Although no analytic function of ϵ which removes the distortion of the conical field relative to the cylindrical field can be found, it is possible to transform the field in such a way that the distortion is removed in the neighborhood of the airfoil in the plane $z = 0$. The desired transformation is obtained from the fact that

$$\frac{y + iz}{x} = \frac{2\epsilon}{1 + \epsilon\bar{\epsilon}}$$

Since $\epsilon\bar{\epsilon}$ approaches ϵ^2 near $z = 0$, the analytic variable

$$z = \frac{2\epsilon}{1 + \epsilon^2}$$

will approach $\frac{y + iz}{x}$ in the neighborhood of the chord plane inside the Mach cone. The new variable z greatly simplifies the boundary conditions inasmuch as the Mach cone is transformed into the positive and negative branches of the real axis outside ± 1 and the interior of the Mach cone is mapped into the whole plane. Figure 3 illustrates the effect of this change of variable.

The relation between u and w in the conical field is found from the conditions for irrotational flow; that is,

$$\frac{\partial w}{\partial x} = \frac{\partial u}{\partial z}$$

In terms of the variable ϵ

$$dw = \frac{1}{2} \left(\epsilon - \frac{1}{\epsilon} \right) du$$

or in terms of the variable z

$$w = -i \int \frac{\sqrt{1 - z^2}}{z} du$$

It is interesting to note that the condition for a flat airfoil surface in two-dimensional flow holds also for the conical field. In the two-dimensional flow $w = iu$ and the condition for a flat surface (constant w) is simply that the function adopted for u has no imaginary part over the region of the real axis covered by the airfoil (assuming that the real

solutions for u and w are used). In the conical flow, the quantity $\frac{\sqrt{1-z^2}}{z}$ is a real number over that part of the real axis between ± 1 so that in this region the condition is unchanged.

Figure 4 illustrates the solution for the flat triangular airfoil at a small angle of attack as obtained by H. J. Stewart and M. I. Gurevich (references 6 and 7) and also by Bartels and LaPorte (reference 8). The constant value of w , denoted by w_c , must be calculated to give the relation between the lifting pressure and the angle of attack. The quantity m is the cotangent of the sweepback angle for $M = \sqrt{2}$; for other Mach numbers $m = \sqrt{M^2 - 1}$ times the cotangent of the sweep angle.

Other wing forms generally require the superposition of conical and cylindrical fields. Thus, in the case of the rectangular wing of wedge-shaped section (fig. 5) the field is cylindrical up to the Mach cone originating at the corner of the wing and is conical inside this cone.

The solution for the flat triangular wing can be used as a starting point to obtain the pressure distribution over a sweptback wing. In this process, which is explained in references 9 and 10, the desired wing plan form is, in effect, cut out of the triangle by the superposition of conical fields which cancel the lifting pressure over portions of the triangular area extending beyond the desired outline. The process is simplified in the supersonic case by the limited zone of influence of the superimposed fields. The lifting pressure distribution over a wing with 63° sweepback is shown in figure 6. It will be noted that the lift distribution over the foremost section is flat, as in the Ackeret theory, while farther along the span the subsonic type of pressure distribution appropriate to the reduced crosswise velocity appears. In this example the wing tips were cut off in a direction parallel to the air stream and, in such cases, the lift drops sharply to zero in the region behind the Mach cone from the tip corner.

The solution for a sweptback wing having curvilinear sections cannot be obtained by the superposition of a finite number of conical fields but requires an integration. Such a case is illustrated in figure 7, which shows the pressure distributions at several sections of a symmetrical biconvex wing at 0° angle of attack. This example serves to illustrate the change in proceeding from subsonic to supersonic speed. Since the angle of sweepback is large, the change is not pronounced and occurs primarily at the center sections of the wing. It is interesting to note that the center sections of the wing have a pressure drag at subsonic speeds.

REFERENCES

1. Busemann, A.: Infinitesimal Conical Supersonic Flow. NACA TM No. 1100, 1947.
2. Jones, Robert T.: Wing Plan Forms for High-Speed Flight. NACA TN No. 1033, 1946.
3. Whittaker, E. T., and Watson, G. N.: A Course of Modern Analysis. Fourth ed., Cambridge Univ. Press (London), 1927, p. 403. (Reprinted 1940.)
4. Bateman, H.: Partial Differential Equations of Mathematical Physics. American ed., Dover Publications, 1944, pp. 357-358.
5. Jones, Robert T.: Properties of Low-Aspect-Ratio Pointed Wings at Speeds below and above the Speed of Sound. NACA Rep. No. 835, 1946.
6. Gurevich, M. I.: Lift Force of an Arrow-Shaped Wing. Appl. Math. and Mech. (Moscow), vol. X, no. 4, 1946, pp. 513-520.
7. Stewart, H. J.: The Lift of a Delta Wing at Supersonic Speeds. Quarterly Appl. Math., vol. IV, no. 3, Oct. 1946, pp. 246-254.
8. LaPorte, O., and Bartels, R. C. F.: An Investigation of the Exact Solutions of the Linearized Equations for the Flow past Conical Bodies. Bumblebee Rep. No. 75, Univ. Michigan, Eng. Res. Inst., Feb. 1948.
9. Cohen, Doris: The Theoretical Lift of Flat Swept-Back Wings at Supersonic Speeds. NACA TN No. 1555, 1948.
10. Lagerstrom, P. A.: Linearized Supersonic Theory of Conical Wings. J.P.L. Progress Rep. No. 4-36, Calif. Inst. Tech., 1947.

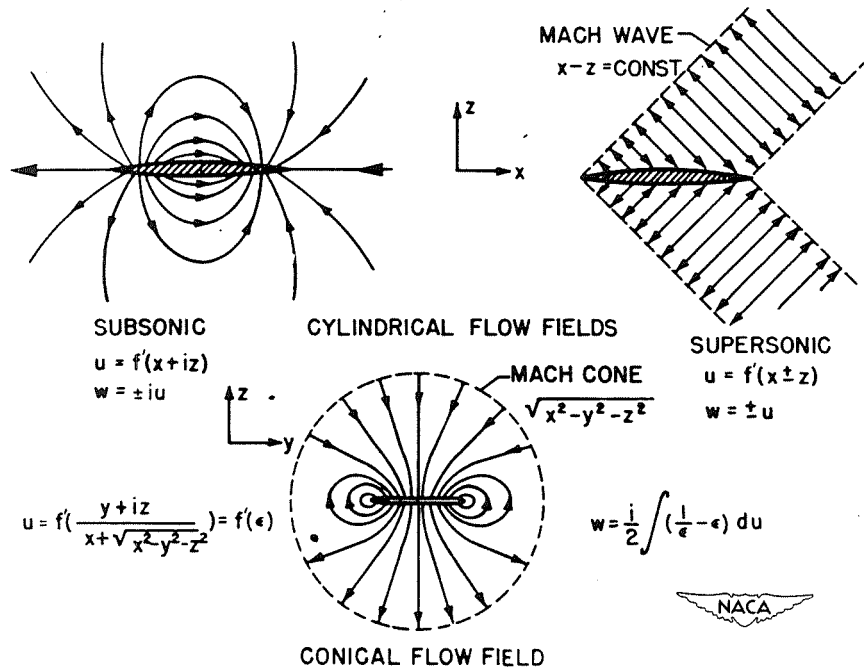

Figure 1.- General form of cylindrical and conical flow fields.

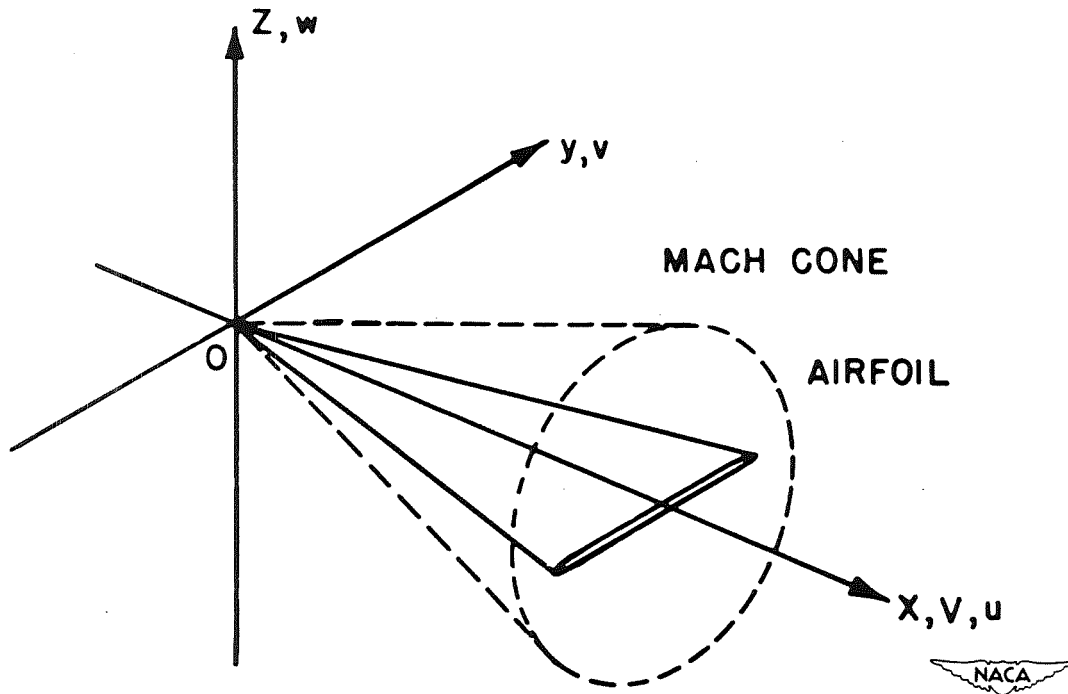

Figure 2.- Flat plate of triangular plan form in conical flow field.

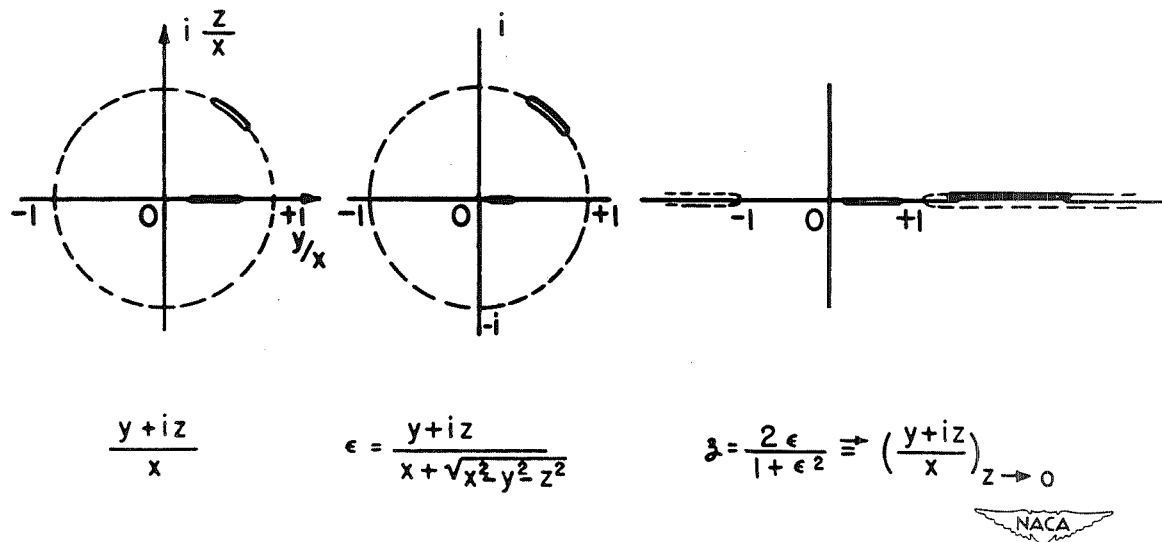

Figure 3.- Transformation of flow field to the $z = 0$ plane.

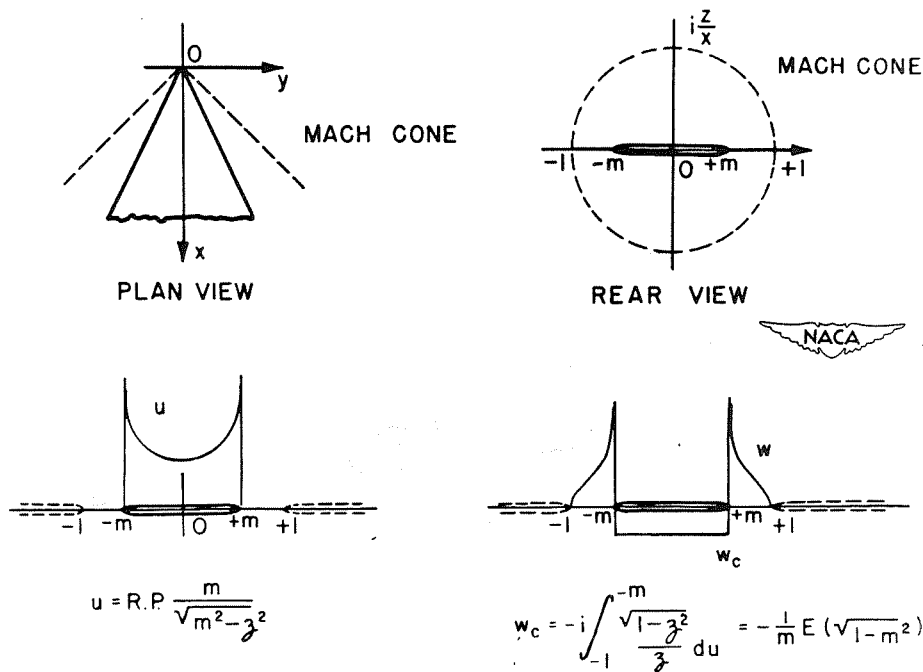

Figure 4.- Solution for flat triangular airfoil at small angle of attack.

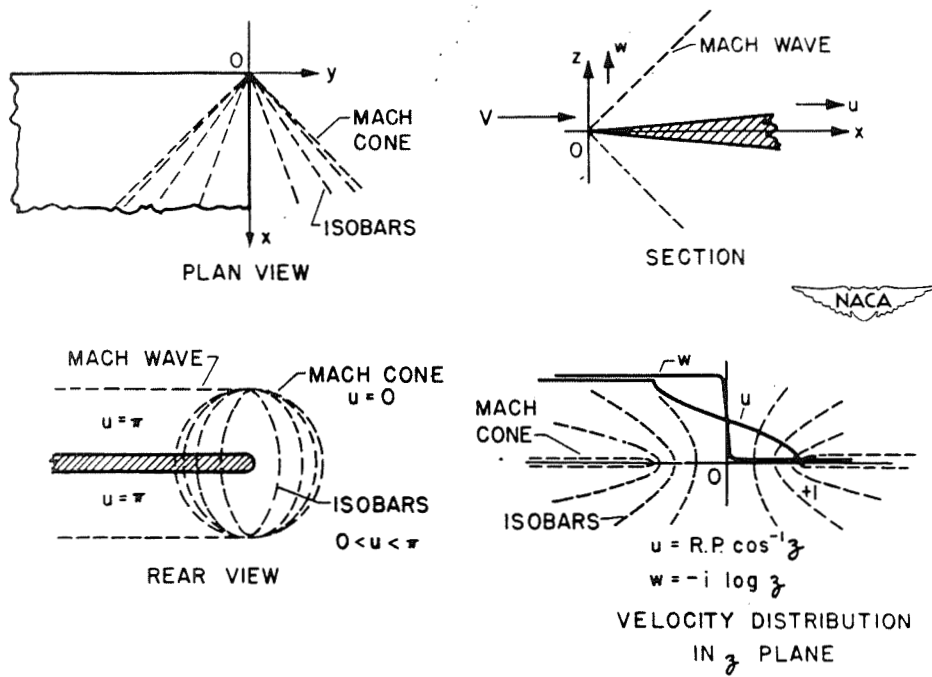

Figure 5.- Cylindrical and conical flow fields about a rectangular wing having a wedge-shape section.

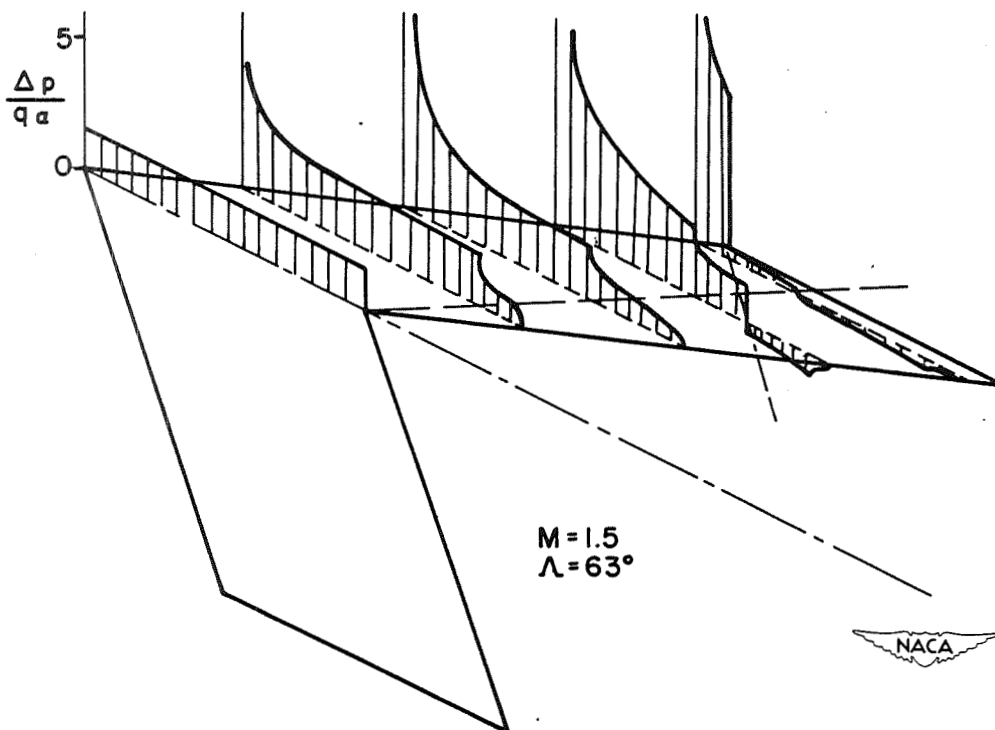

Figure 6.- Lifting pressure distribution over a wing with 63° sweepback.

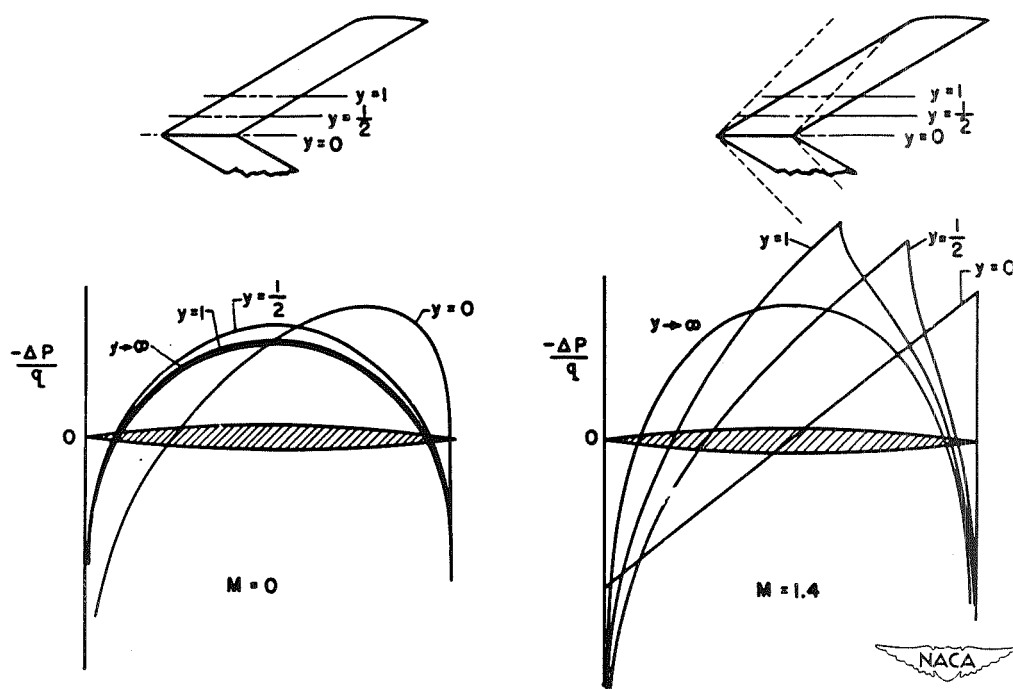

Figure 7.- Pressure distributions at several sections of a symmetrical biconvex wing at 0° angle of attack.