

# NASA Contractor Report 2857

NASA  
CR  
2857  
v.1  
c.1

NON-COPY: RETURN  
TO: TECHNICAL LIBRARY  
WRIGHT AFB, N.C.



## Random Harmonic Analysis Program, L221 (TEV156) Volume I: Engineering and Usage

R. D. Miller and M. L. Graham

CONTRACT NAS1-13918  
OCTOBER 1979

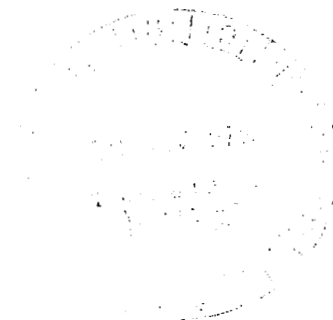



**NASA Contractor Report 2857**

**Random Harmonic Analysis  
Program, L221 (TEV156)**

**Volume I: Engineering and Usage**

**R. D. Miller and M. L. Graham**  
*Boeing Commercial Airplane Company*  
*Seattle, Washington*

**Prepared for**  
**Langley Research Center**  
**under Contract NAS1-13918**

**NASA**

National Aeronautics  
and Space Administration

**Scientific and Technical  
Information Branch**

1979



# CONTENTS

	Page
1.0 SUMMARY .....	1
2.0 INTRODUCTION .....	3
3.0 SYMBOLS AND ABBREVIATIONS .....	4
4.0 ENGINEERING AND MATHEMATICAL DESCRIPTION .....	8
4.1 Equations of Motion .....	8
4.2 Load Equations .....	10
4.3 Solution Technique .....	11
5.0 PROGRAM STRUCTURE AND DESCRIPTION .....	14
5.1 Program L221 .....	14
5.2 Program FINDRMS .....	16
5.3 Program SORTQLS .....	19
5.4 Program PLOTQLS .....	21
6.0 COMPUTER PROGRAM USAGE .....	22
6.1 Control Cards .....	22
6.2 Resource Estimates .....	23
6.3 Card Input Data .....	27
6.3.1 Format of Card Input Data .....	30
6.3.2 Program L221 .....	32
6.3.3 Program FINDRMS .....	34
6.3.4 Program SORTQLS .....	78
6.3.5 Program PLOTQLS .....	88
6.3.6 Summary of Card Input Data .....	101
6.4 Magnetic Files Input Data .....	107
6.4.1 "INTAPE" .....	107
6.4.2 "LDTAPE" .....	110
6.4.3 "IFTAPE" .....	110
6.5 Output Data .....	113
6.5.1 Printed Output Data .....	113
6.5.2 Magnetic Files Output Data .....	113
6.5.3 Punched Cards .....	117
6.6 Restrictions .....	118
6.7 Diagnostics .....	119
6.7.1 READTP Error Codes .....	120
6.7.2 WRTE TP Error Codes .....	121
6.7.3 PRINTM/PRNTCM Error Codes .....	121
6.7.4 VARDIM Routine Error Codes .....	121
6.7.5 FETEDIT Error Codes .....	122

<b>7.0 SAMPLE PROBLEM .....</b>	<b>123</b>
<b>APPENDIX A - FREQUENCY ARRAY FORMULATION .....</b>	<b>143</b>
<b>APPENDIX B - SPECIAL FEEDBACK .....</b>	<b>146</b>
<b>APPENDIX C - MULTIPLE EXCITATION FORCING FUNCTIONS .....</b>	<b>148</b>
<b>REFERENCES .....</b>	<b>151</b>

## TABLES

No.		Page
1	Resources Used by Sample Problems .....	24
2	Primary Overlays and Data Set Numbers .....	28
3	<i>Coefficients for the Wagner Indicial Lift Growth Function at <math>M = 0</math></i> .....	46
4	<i>Coefficients for the Kussner Indicial Lift Growth Function at <math>M = 0</math></i> .....	46

## FIGURES

No.		Page
1	L221 (TEV156) Overlay Structure and Input/Output Files .....	15
2	Flow of L221 (TEV156) Card Input Data .....	29
3	Flow of FINDRMS Block I Card Input Data .....	35
4	Flow of FINDRMS Block II Card Input Data .....	60
5	Flow of FINDRMS Block III Card Input Data .....	69
6	Flow of SORTQLS Card Input Data .....	80
7	Flow of PLOTQLS Card Input Data .....	90
8	Contents of the File "INTAPE" .....	108
9	Contents of the File "LDTAPE" .....	111
10	Contents of the File "IFTAPE" .....	112
11	Contents of the File "IPLTPE" .....	114
12	Contents of the File "IRTAPE" .....	115
13	Contents of the File "NEWTPE" .....	116
14	Format of $\{\bar{A}\}$ and $\{N_0\}$ Punched on Cards .....	117

## **Note**

**The automatic plotting overlay PLOTQLS in this program requires subroutines that are proprietary to The Boeing Company. Consequently, this overlay can only be accessed on the Boeing Computer.**

## 1.0 SUMMARY

This document describes the analysis and use of program L221 (TEV156), a digital computer program to calculate steady state solutions for linear second-order differential equations caused by sinusoidal forcing functions. The program calculates generalized coordinate frequency responses, load frequency responses, and load power spectral density (PSD) parameters using random harmonic analysis techniques. The particular field of application of the program is the analysis of airplane response and loads caused by continuous air turbulence, both vertical and lateral gusts.

The equations of motion and load equations of the vehicle must be formulated outside L221 (TEV156) and read as program input data from either cards or magnetic files. The frequency response functions for the generalized coordinates and loads (shears, moments, accelerations, etc.) are solved at a large number of discrete frequencies. An empirical representation of the atmospheric turbulence PSD is utilized together with the load frequency response functions to obtain the load PSD parameters  $\bar{A}$  and  $N_0$  (root mean square (RMS) load/root mean square gust velocity and the number of zero crossings with positive slope per unit distance, respectively).

A number of options are available within the program to produce flexibility as to the type of solution and results desired. Some of these features are:

- Equations of motion and load equation coefficient matrices may be either frequency dependent (nonconstant coefficients) or frequency independent (constant coefficients)
- User selection of gust spectra description
- User-specified scale of turbulence
- Multiple forcing function spectra description
- Static-elastic solution for quasi-steady path
- Deletion of user-specified degrees of freedom
- User-specified structural damping factor for each degree of freedom
- User-specified starting point for RMS integration



- User-specified Wagner and Küssner indicial lift growth function coefficients
- Gradual gust penetration
- Load correlation
- User input or internal generation of the array of solution frequencies

The following results can be saved on magnetic tape for automatic plotting with user-supplied interface and plotting programs:

- Frequency response functions for the generalized coordinates\*
- Frequency response functions for the loads\*
- Load power spectra functions\*
- Real and imaginary components of the generalized coordinate frequency responses
- Real and imaginary components of the load frequency responses
- RMS loads,  $\bar{A}$ \*

\*These items can also be automatically plotted using the COMp80 plotter.

Limitations imposed on the equations are:

- All roots must have positive damping.  
 Note: A solution will occur even though the damping is negative; however, it will be in error as no steady state solution exists.
- The matrix which is the sum of the zero-, first-, and second-order coefficients must be nonsingular at all solution frequencies.

## 2.0 INTRODUCTION

The computer program L221(TEV156) may be used as either a stand-alone program or as a module of a program system called DYLOFLEX which was developed for NASA under contract NAS1-13918 (ref. 1). Because of the DYLOFLEX contract requirements developed in reference 2, a program was needed to calculate power spectral density (PSD) gust load parameters for equations of motion and load equations which have frequency-dependent coefficients. An existing program<sup>1</sup> that calculated PSD gust load parameters for equations with constant coefficients was modified according to the DYLOFLEX specifications,<sup>2</sup> to optionally use nonconstant coefficient matrices for the equations of motion and load equations.

---

<sup>1</sup>Clemmons, R. E.: *A Power Spectral Digital Computer Program to Determine Dynamic Loads due to Random Gusts-PSDSYS (TEV156)-Users Guide*. BCS-G0235, June 1973.

<sup>2</sup>Clemmons, R. E.: *Programming Specifications for Modules of the Dynamic Loads System to Interface With FLEXSTAB*. NASA contract NAS1-13918, BCS-G0701, September 1975.  
(Internal Documents)

### 3.0 SYMBOLS AND ABBREVIATIONS

The following list contains items that appear in this document except section 6.3 (card input).

<u>Engineering notation</u>	<u>Definition</u>
$\{\bar{A}\}$	Gust response factor = $\sigma_r/\sigma_g$ , response/unit velocity.
$[A], [B]$	Real and complex coefficients of the AIC matrix.
$[AIC]$	Aerodynamic influence coefficient matrix.
$a_1, b_1, c_1, d_1$	Wagner indicial lift growth coefficients.
$a_2, b_2, c_2, d_2$	Küssner indicial lift growth coefficients.
$c$	Reference chord length, units of length
$C$	Scalar constant on the equations of motion forcing function when using gradual penetration.
$\bar{C}$	Scalar constant on the load equation forcing function when using gradual penetration.
$\{C_2\}, [C_2]$	Equations of motion forcing function coefficient matrix.
$\{\bar{C}_2\}, [\bar{C}_2]$	Load equations forcing function coefficient matrix.
$\{C_3\}, [C_3]$	Equations of motion convoluted forcing function coefficient matrix.
$\{\bar{C}_3\}, [\bar{C}_3]$	Load equations convoluted forcing function coefficient matrix.
$\{CS0\}, \{CS1\}, \{CS2\}$	Special feedback coefficients.
$\{F_a\}$	Aerodynamic force.
$\{f_\ell\}$ or $i \quad \ell$	Streamwise distance from the point first encountering gust to the points encountering the gust later, units of length
$\{FREQM\}$	Array of frequencies at which the frequency-dependent input matrices are defined.
$f(s)$	Laplace transform of the Küssner indicial lift growth function.

Fydamp	Special feedback transfer function.
G	Feedback gain coefficient of the feedback transfer function.
{gSD}	Structural damping coefficient matrix.
g(s)	Laplace transform of the Wagner indicial lift growth function.
i	$\sqrt{-1}$
L	Scale of turbulence, units of length.
[M]	Lumped inertial data.
[M <sub>1</sub> ],[M <sub>2</sub> ],[M <sub>3</sub> ]	Equations of motion coefficient matrices for generalized coordinate displacement, rate, and acceleration, respectively.
[M <sub>4</sub> ],[M <sub>5</sub> ],[M <sub>6</sub> ],	Equations of motion coefficient matrices for convoluted generalized coordinate displacement, rate, and acceleration, respectively.
[M̄ <sub>1</sub> ],[M̄ <sub>2</sub> ],[M̄ <sub>3</sub> ]	Load equations coefficient matrices for generalized coordinate displacement, rate, and acceleration, respectively.
[M̄ <sub>4</sub> ],[M̄ <sub>5</sub> ],[M̄ <sub>6</sub> ]	Load equations coefficient matrices for convoluted generalized coordinate displacement, rate, and acceleration, respectively.
{N <sub>0</sub> }	Number of zero crossings with positive slope per distance.
{P}	Coefficients of the special feedback transfer function. P(1),P(2),P(3) and P(4),P(5),P(6),P(7) are the second-order functional coefficients for the numerator and denominator, respectively.
q̄	Dynamic pressure, fore/unit area
{Q} or {q}	Generalized coordinates of the equations.
QMAG <sub>L</sub>	Magnitude of the load solution at each solution frequency.
QMAG <sub>R</sub>	Magnitude of the generalized coordinates at each solution frequency.
{R}	Coefficients of the special feedback transfer function. R(1),R(2),R(3) and R(4),R(5),R(6),R(7) are the zero-order functional coefficients for the numerator and denominator, respectively.

s

[S<sub>1</sub>],[S<sub>2</sub>],[S<sub>3</sub>]

[S<sub>4</sub>],[S<sub>5</sub>],[S<sub>6</sub>]

[S̄<sub>1</sub>],[S̄<sub>2</sub>],[S̄<sub>3</sub>]

[S̄<sub>4</sub>],[S̄<sub>5</sub>],[S̄<sub>6</sub>]

[SPEC]

{SUMC}

{SUMC}

[SUMM]

[SUMM]

{T}

{u}

V<sub>T</sub>

{W}

{W<sub>gi</sub>}

T(iΩ)

Z

α<sub>1</sub>,β<sub>1</sub>,γ<sub>1</sub>

Laplace operator = iω.

Equations of motion special feedback coefficient matrices for generalized coordinate displacement, rate, and acceleration, respectively.

Equations of motion special feedback coefficient matrices for convoluted generalized coordinate displacement, rate, and acceleration, respectively.

Load equations special feedback coefficients matrices for generalized coordinate displacement, rate, and acceleration, respectively.

Load equations special feedback coefficient matrices for convoluted generalized coordinate displacement, rate, and acceleration, respectively.

Load output spectrum at each solution frequency.

Equations of motion forcing function summation matrix.

Load solutions at each solution frequency.

Generalized coordinate summation matrix.

Load equations summation matrix for generalized coordinates.

Coefficients of the special feedback transfer function. T(1) and T(2),T(3),T(4),T(5),T(6),T(7) are first-order functional coefficients for the numerator and denominator, respectively.

Coefficients of the special feedback transfer function. U(1),U(2),U(3), and U(4),U(5),U(6),U(7) are first-order function coefficients for the numerator and denominator, respectively.

True airspeed velocity, length/sec.

Normalwash.

Normalwash caused by the gust from point i.

Complex frequency response function.

Scale factor on forcing function.

Wagner indicial lift growth coefficients.

$\alpha_2, \beta_2, \gamma_2$

$\alpha_g$

$\Phi(t)$

$\psi(t)$

$\phi$

$\phi'$

$\phi_g$

$\sigma_r$

$\sigma_g$

$\Phi(\Omega)$

$\Omega$

$\omega$

$\mathcal{L}$

$[\tilde{\phi}]$

$[\bar{\phi}]$

$\zeta$

$\delta_R$

$\delta_{Rlim}$

$\kappa$

$\eta$

$[\ ]$

$[ \ ]$

$\{ \}$

$[ \circ ]$

$[ \ ]^T$

\*

$\Re$

Küssner indicial lift growth coefficients.

Gust angle, radians.

Wagner function.

Küssner function.

Mode deflection

Mode slope.

Gust mode shape.

Root mean square (RMS) of response.

Root mean square of gust velocity with zero mean.

Gust spectrum.

Spatial frequency =  $\omega/V$ , radian/unit length

Frequency, rad/s.

Laplace transform.

Equations of motion gradual penetration forcing function matrix.

Load equations gradual penetration forcing function matrix.

Structural damping factor.

Rudder angle.

Rudder limit for special feedback transfer function.

Constant for the exponential input spectrum.

Exponential power constant for the exponential input spectrum.

Row matrix.

Rectangular matrix.

Column matrix.

Diagonal matrix.

Transpose of the matrix.

Indicates convolution.

Real part of complex number.

## 4.0 ENGINEERING AND MATHEMATICAL DESCRIPTION

This program is capable of calculating steady state solutions for any linear second-order differential equations caused by sinusoidal forcing functions. Statistical characteristics of loads for the forcing function spectral shape may also be calculated using random harmonic analysis techniques.

The following engineering description is for the specific field of application: the analysis of airplane response and loads due to continuous random atmospheric turbulence.

### 4.1 EQUATIONS OF MOTION

In general, the equations of motion consist essentially of three parts:

1. Structural (generalized stiffness, inertia, and damping)
2. Aerodynamic (generalized response and excitation air forces)
3. Stability augmentation system (SAS) (equations relating system transfer functions and sensor signals)

The equations of motion can be represented in the form:

(Structural + SAS) + (Response Aerodynamics) = (Gust Excitation Aerodynamics)

$$\begin{aligned} & ([M_1]\{\ddot{q}\} + [M_2]\{\dot{q}\} + [M_3]\{q\}) + ([M_4]\{\dot{q}\}*\Phi + [M_5]\{q\}*\Phi) \\ & = -Z (\{C_2\}\alpha_g + \{C_3\}\dot{\alpha}_g*\psi) \end{aligned} \quad (1)$$

where:

- $M$ 's,  $C$ 's = Appropriate matrix coefficients
- $q$ 's = Generalized coordinates including SAS degrees of freedom
- $\alpha_g$  = Gust angle
- $\Phi$  = Wagner function (equal one for no lift growth)
- $\psi$  = Küssner function (equal one for no lift growth)
- \* Indicates convolution

The composition of  $[M_1]$ ,  $[M_2]$ , and  $[M_3]$  can be visually partitioned into the structural and SAS submatrices

$$[M_i]_{i=1,3} = \begin{bmatrix} M_{i\text{struct}} \\ M_{i\text{SAS}} \end{bmatrix}_{i=1,3} \quad (2)$$

where:

$[M_{1\text{struct}}]$  = Generalized structural stiffness

$[M_{2\text{struct}}]$  = Generalized structural damping

$[M_{3\text{struct}}]$  = Generalized structural inertia

The generalized structural inertia  $[M_{3\text{struct}}] = [\phi]^T[M][\phi]$  and the structural stiffness  $[M_{1\text{struct}}] = [\omega^2][\phi]^T[M][\phi]$  are usually formed in vibration programs which require only geometric, structural stiffness, and mass data.

Generally, structural damping is assumed to be proportional to displacement but in phase with velocity. It can be written in the present notation as:

$$i[g_{SD}][M_{1\text{struct}}]\{\dot{q}\} \quad (3)$$

where  $g_{SD} = 2$  (structural damping factor,  $\zeta$ , on each degree of freedom).

This representation is generally associated with harmonic motion and is built into this program as an option. However, if an equivalent viscous damping representation is desired, the structural damping can be transformed into an equivalent viscous damping representation given as,

$$[g_{SD}][M_{1\text{struct}}]^{1/2}[M_{3\text{struct}}]^{1/2}\{\dot{q}\} \quad (4)$$

This representation is sometimes used with harmonic motion. However, it should be noted that when this method is used, the structural damping factor will vary with frequency and have a value of  $g_{SD}/2$  only at the natural frequency of each mode.

The coefficients  $[M_{i\text{SAS}}]_{i=1,3}$  represent the definition of the SAS equations and are not a function of the aerodynamic representation. Therefore, they are placed in the  $M_1$  through  $M_3$  matrices.

Because this is a general-purpose program, the  $M_4$  and  $M_5$  matrices usually consist of the generalized response aerodynamic forces, with that portion of  $M_4$  and  $M_5$  corresponding to the SAS submatrices in  $M_1$ ,  $M_2$ , and  $M_3$  equal to zero. The generalized response aerodynamic matrices are formed by the expression:

$$[\phi]^T\{F_a\}$$

where:

$\{F_a\}$  = Aerodynamic force

$[\phi]$  = Mode deflection



In general, the aerodynamic force is given as

$$\{F_a\} = \bar{q}[AIC]\{W\} \quad (5)$$

where:

$$\begin{aligned} \{W\} &= \text{Normalwash vector} \\ &= [\phi']\{q\} + \frac{1}{V_T} [\phi]\{\dot{q}\} \end{aligned}$$

$$\bar{q} = \text{Dynamic pressure}$$

$$[\phi'] = \text{Mode slope}$$

$$[AIC] = [A] + i[B]; [B] = 0 \text{ if (reduced frequency) } k = 0$$

Note:  $M_4$  and  $M_5$  are only valid for the specific  $\omega$  corresponding to the reduced frequency,  $k$ , that was used to calculate the imaginary AIC matrix  $[B]$ .

The generalized excitation matrix  $\{C_3\}$ , which is generally caused by gust, may remain complex and similarly may be written:

$$\{C_3\}\alpha_g = \bar{q}[\phi]^T[AIC]\{W_g\} \quad (6)$$

where  $\{W_g\} = \{\phi_g\}e^{i\omega t}$  for harmonic motion,

also

$$\begin{aligned} W_{gi} &= e^{i\omega \left(t - \frac{l_i}{V}\right)} \\ &= e^{i\omega t} e^{-i\omega \frac{l_i}{V}} \end{aligned}$$

then

$$\{W_g\} = \left\{ e^{-i\omega \frac{l_i}{V}} \right\} e^{i\omega t} \quad (7)$$

so define

$$\{\phi_g\} = \left\{ e^{-i\omega \frac{l_i}{V}} \right\}$$

Note: If  $l_i = 0$  (no gust penetration), then  $\{\phi_g\} = \{1\}$ .

## 4.2 LOAD EQUATIONS

The load equations follow the same format as the equations of motion.

$$\begin{aligned} \{\text{Load}\} = & [\bar{M}_1]\{q\} + [\bar{M}_2]\{\dot{q}\} + [\bar{M}_3]\{\ddot{q}\} \\ & + [\bar{M}_4]\{\dot{q}\}*\Phi + [\bar{M}_5]\{\ddot{q}\}*\Phi + |Z|([\bar{C}_2]\alpha_g + \{\bar{C}_3\}\dot{\alpha}_g*\psi) \end{aligned} \quad (9)$$

where:

$[\bar{M}_1], [\bar{M}_2], [\bar{M}_3]$  = Load matrix coefficients of the generalized coordinate displacement, rate, and acceleration, respectively

$[\bar{M}_4], [\bar{M}_5]$  = Load matrix coefficients of the generalized coordinate rate and acceleration convoluted with the Wagner function

$\{\bar{C}_2\}$  = Load matrix coefficient of the excitation function (usually gust angle  $\alpha_g$ )

$\{\bar{C}_3\}$  = Load matrix coefficient of the excitation function convoluted with the Küssner function

$\Phi$  = Wagner function

$\psi$  = Küssner function

$q, \dot{q}, \ddot{q}$  = Generalized coordinate displacement, velocity, and acceleration responses, respectively

\*

Indicates convolution

Relating these matrices in a physical sense,  $[\bar{M}_1]$ ,  $[\bar{M}_2]$ , and  $[\bar{M}_3]$  are usually associated with the load resulting from structural response;  $[\bar{M}_4]$  and  $[\bar{M}_5]$  are usually associated with the load resulting from aerodynamic response;  $\{\bar{C}_3\}$  is usually associated with the load resulting from the gust excitation force.

### 4.3 SOLUTION TECHNIQUE

The steady state solution for the equations of motion and load equations caused by sinusoidal forcing functions is obtained by using the Laplace transform technique. Taking the Laplace transform of the equations of motion and load equations results in the form:

Equations of Motion

$$\begin{aligned} [M_1] + [ig_{SD}\overset{\circ}{M}_{1_{struct}}] + s[M_2] + s^2[M_3] + g(s)[M_4] + sg(s)[M_5] \{\mathcal{L}(q)\} \\ = -Z \left[ \{C_2\} + f(s)\{C_3\} \right] \mathcal{L}(\alpha_g) \end{aligned} \quad (10)$$

where:

$$g(s) = s \mathcal{L} [\Phi] = a_1 - \frac{b_1 s}{s + \alpha_1} - \frac{c_1 s}{s + \beta_1} - \frac{d_1 s}{s + \gamma_1}$$

$$f(s) = s \mathcal{L} [\psi] = a_2 - \frac{b_2 s}{s + \alpha_2} - \frac{c_2 s}{s + \beta_2} - \frac{d_2 s}{s + \gamma_2}$$

**gSD** = Structural damping factor

**Z** = Scaling factor

**s** = Laplace operator =  $i\omega$

and using the relationship that the Laplace transform of the convolution theorem gives Duhamel's formula:

$$\mathcal{L} [f(t)] \mathcal{L} [q(t)] = \mathcal{L} \left[ \int_0^t f(t - \lambda) q(\lambda) d\lambda \right] \quad (11)$$

Load Equations

$$\begin{aligned} \text{Load} = & \left\{ [\bar{M}_1] + s[\bar{M}_2] + s^2[\bar{M}_3] + g(s)[\bar{M}_4] + sg(s)[\bar{M}_5] \right\} \{ \mathcal{L}(q) \} \\ & + |Z| \{ \{ \bar{C}_2 \} + f(s) \{ \bar{C}_3 \} \} \mathcal{L}(\alpha_g) \end{aligned} \quad (12)$$

Thus, generalized coordinated and load frequency response functions are easily obtained by solving equations (10) and (12).

The matrix coefficients for the equations of motion and load equations may be either independent of frequency or frequency dependent. However, for the frequency-dependent matrices, a linear interpolation of the matrix coefficients is used to form additional matrices at frequencies intermediate to those formed external to this program. This interpolation process is necessary so that the equations of motion and load equations may be evaluated at a sufficient number of frequencies to adequately define the frequency response function, while generating as few input matrices as necessary. The selection of frequencies is dependent upon the damping in the system, the frequency range over which the contribution of the responses significantly affect the final RMS loads, the number of modes used, and the frequency separation between modes. For typically low-damped dynamic models, this requires the solution of the equations of motion at a large number of frequencies (on the order of 200 to 250). The selection of frequencies is delegated to the engineering user, and the number must be kept to a minimum to reduce costs, yet must be sufficient to adequately define the frequency response functions. This interpolation is required for only the response and gust excitation aerodynamic matrices since the structural matrices and the SAS equations remain constant with frequency.

Power spectral density (PSD) load parameters, root mean square (RMS) load/root mean square gust velocity ( $\bar{A}$ ), and number of zero crossings ( $N_0$ ) can be calculated using the load frequency response functions. The equations for  $\bar{A}$  and  $N_0$  are

$$\bar{A} = \left[ \int_0^{\infty} |T(i\Omega)|^2 \Phi(\Omega) d\Omega \right]^{1/2} \quad (13)$$

and

$$N_0 = \frac{1}{2\pi\bar{A}} \left[ \int_0^{\infty} \Omega^2 |T(i\Omega)|^2 \Phi(\Omega) d\Omega \right]^{1/2} \quad (14)$$

where:

$T(i\Omega)$  = Load frequency response

$\Phi(\Omega)$  = Gust spectrum

In practice, the upper limit (infinity) of the integral is replaced by the finite value of the last discrete frequency used in the solution of the transfer function.

## 5.0 PROGRAM STRUCTURE AND DESCRIPTION

Program L221 (TEV156) has been constructed as an overlay system consisting of a main overlay and three primary overlays:

Main overlay	(L221,0,0)	L221
Primary overlay	(L221,1,0)	FINDRMS
Primary overlay	(L221,2,0)	-SORTQLS
Primary overlay	(L221,3,0)	PLOTQLS

The main overlay L221 simply reads cards to determine which primary overlays are to be called, calls the proper primary overlays into execution, and aids in communication between overlays through labeled common blocks.

FINDRMS performs the actual calculations of L221 (TEV156).

SORTQLS sorts the results of FINDRMS and prepares a magnetic file of data vectors suitable for plotting.

PLOTQLS sorts the results of FINDRMS and prepares a magnetic file of plot instructions for the COMp80 plotter.

A schematic of the L221 (TEV156) overlay structure is presented in figure 1. A description of each overlay follows.

### 5.1 PROGRAM L221

L221 is the program name of the (L221,0,0) overlay. This overlay repeatedly reads cards to determine the type of execution to be performed and calls primary overlays to perform the necessary operations.

The following is a list of keywords used to control the execution of the system's primary overlays.

<b>\$FREQUENCY</b>	Indicates that the input data following this card is for use by L221 (TEV156).
<b>\$TITLE</b>	Is printed and ignored.
<b>\$FINDRms</b>	Causes the execution of program FINDRMS, (L221,1,0), which performs all of the computations of L221 (TEV156).
<b>\$SORTqls</b>	Causes the execution of program SORTQLS, (L221,2,0), which sorts the results of FINDRMS and prepares a magnetic file of data vectors suitable for plotting.



\$PLOTqls	Causes the execution of program PLOTQLS, (L221,3,0), which sorts the results of FINDRMS and prepares a magnetic file of plot instructions for the COMp80 plotter.
\$CORE	Causes the maximum field length limit to be changed. The field length limit default value is 200000 octal.
\$CHECK	Triggers a special option to aid a programmer testing fatal error logic paths within L221 (TEV156). The option causes the clearing of the fatal error flag and allows execution to continue. This option is <i>not</i> intended for use during normal program executions.
\$QUIT	Causes L221 (TEV156) to terminate execution.

## 5.2 PROGRAM FINDRMS

Program FINDRMS, overlay (L221,1,0), performs all of the computations of L221 (TEV156). Given an input power spectrum  $\Phi(\Omega)$  over a range of frequencies ( $\Omega_1, \Omega_2, \dots, \Omega_{NFREQ}$ ), matrices of equations of motion, load equations, and excitation forces, FINDRMS will find:

{Q}            Response function of the generalized coordinates at each solution frequency

{SUMC}        Response function of the load at each solution frequency

and integrate over the range of frequencies to find:

{A}            RMS load values

{N<sub>0</sub>}         Number of zero crossings per unit length

The FINDRMS operations are divided into the following 10 steps to obtain the solutions of the generalized coordinates.

1. Read card input of options and constants.
2. Read card or magnetic file input of equations of motion  $[M_1], [M_2], \dots, [M_6]$  and  $[S_1], [S_2], \dots, [S_6]$  for feedback plus the excitation forces  $\{C_2\}$  and  $\{C_3\}$  or  $\{f_d\}$  and  $\{\phi\}$  for gust penetration. This includes {FREQM} (frequencies associated with k-value aerodynamics) if NKVAL > 0.

Note:  $[M_6], [S_1]$ , and  $\{C_2\}$  are not used when using the DYLOFLEX system.

3. For each of the NFREQ frequencies, solve for {Q} the generalized coordinates, save {Q} on the scratch file, and optionally print {Q}. The generalized coordinates are found by solving the following equation.

$$[SUMM] \{Q\} = \{SUMC\} \quad (15)$$

where:

$$[\text{SUMM}] = [\mathbf{M}_1] + i[\mathbf{g}_{\text{SD}}^{\circ}][\dot{\mathbf{M}}_1] + s[\mathbf{M}_2] + s^2[\mathbf{M}_3] + \mathbf{g}(s)[\mathbf{M}_4] + s\mathbf{g}(s)[\mathbf{M}_5] + s^2\mathbf{g}(s)[\mathbf{M}_6] \quad (16)$$

where:

$s = i\omega$ , Laplace transform variable

$\mathbf{g}(s) =$  Laplace transform of the Wagner function

$$= a_1 - \frac{b_1 s}{s + \alpha_1} - \frac{c_1 s}{s + \beta_1} - \frac{d_1 s}{s + \gamma_1}$$

For a solution with feedback, the following terms are also added to  $[\text{SUMM}]$ .

$$\text{Fydamp} \left[ [\mathbf{S}_1] + s[\mathbf{S}_2] + s^2[\mathbf{S}_3] + \mathbf{g}(s)[\mathbf{S}_4] + s\mathbf{g}(s)[\mathbf{S}_5] + s^2\mathbf{g}(s)[\mathbf{S}_6] \right] \quad (17)$$

where:

$$\text{Fydamp} = \frac{G(P_1 s^2 + U_1 s + R_1)(P_2 s^2 + U_2 s + R_2)(P_3 s^2 + U_3 s + R_3)(T_1 s + 1)}{(P_4 s^2 + U_4 s + R_4) \dots (P_7 s^2 + U_7 s + R_7)(T_2 s + 1) \dots (T_7 s + 1)}$$

$$\{\text{SUMC}\} = -Z \left\{ f(s) \{\mathbf{C}_3\} + \{\mathbf{C}_2\} \right\} \quad (18)$$

where:

$f(s) =$  Laplace transform of the Küssner function

$$= a_2 - \frac{b_2 s}{s + \alpha_2} - \frac{c_2 s}{s + \beta_2} - \frac{d_2 s}{s + \gamma_2}$$

When gradual penetration is requested,  $\{\mathbf{C}_3\}$  is frequency dependent and will be calculated as

$$\{\mathbf{C}_3\} = C \left\{ [\tilde{\phi}] \cos\{\Omega\{f_{\ell}\}\} - i[\tilde{\phi}] \sin\{\Omega\{f_{\ell}\}\} \right\} \quad (19)$$

Note: Optionally, the input matrices  $[\mathbf{M}_4]$ ,  $[\mathbf{M}_5]$ ,  $[\mathbf{M}_6]$ , and  $\{\mathbf{C}_3\}$  or  $[\tilde{\phi}]$  are frequency dependent. Interpolation is required to define those matrices at each frequency (NFREQ), before calculating  $[\text{SUMM}]$ ,  $\{\text{SUMC}\}$ , and  $\{\mathbf{Q}\}$ .

Optionally, the user may specify multiple forcing functions causing the matrices  $\{\mathbf{C}_3\}$ ,  $\{\text{SUMC}\}$ , and  $\{\mathbf{Q}\}$  to be rectangular. (See appendix C for a discussion of the multiple forcing function option.)

Optionally, the user may specify certain degrees of freedom to be deleted. This is accomplished by zeroing the appropriate degrees of freedom in the  $[\text{SUMM}]$  and  $\{\text{SUMC}\}$  matrices.



4. Modify the equations of motion for a static-elastic solution and repeat step 3. Chosen columns of the matrices  $[M_2]$ ,  $[M_3]$ ,  $[M_5]$ , and  $[M_6]$  are set equal to zero for the static-elastic solution; optional.

The loads are solved by the following steps.

5. Read card or magnetic file input of load equations  $[\bar{M}_1]$ ,  $[\bar{M}_2]$ , ...,  $[\bar{M}_6]$  and  $[\bar{S}_1]$ ,  $[\bar{S}_2]$ , ...,  $[\bar{S}_6]$  for feedback plus the matrices  $\{\bar{C}_2\}$  and  $\{\bar{C}_3\}$  or  $\{\bar{\phi}\}$ .

Note:  $[\bar{M}_6]$ ,  $[\bar{S}_1]$ , and  $\{\bar{C}_2\}$  are not used when using the DYLOFLEX system.

6. For each frequency read  $\{Q\}$  (from step 3); calculate  $\{\overline{SUMC}\}$ , the input spectrum  $\phi(\Omega)$ , and the output spectrum  $\{\overline{SPEC}\}$ ; optionally write data on magnetic files "IPLTPE" and "IRTAPE"; optionally print  $\{\overline{SUMC}\}$ , and keep a running integration over the frequencies of  $\{\bar{A}\}$  and  $\{N_0\}$ .

$$\{\overline{SUMC}\} = [\overline{SUMM}]\{Q\} + |Z| \left\{ f(s)\{\bar{C}_3\} + \{\bar{C}_2\} \right\} \quad (20)$$

where:

$$[\overline{SUMM}] = [\bar{M}_1] + s[\bar{M}_2] + s^2[\bar{M}_3] + g(s)[\bar{M}_4] + sg(s)[\bar{M}_5] + s^2g(s)[\bar{M}_6]$$

For a solution with feedback, the following terms are also added to  $[\overline{SUMM}]$ .

$$\text{Fydamp} \left[ [\bar{S}_1] + s[\bar{S}_2] + s^2[\bar{S}_3] + g(s)[\bar{S}_4] + sg(s)[\bar{S}_5] + s^2g(s)[\bar{S}_6] \right] \quad (21)$$

When gradual penetration is requested,  $\{\bar{C}_3\}$  is frequency dependent and will be calculated as:

$$\{\bar{C}_3\} = \bar{C} \left\{ [\bar{\phi}] \cos \left\{ \Omega \{f_\ell\} \right\} - i [\bar{\phi}] \sin \left\{ \Omega \{f_\ell\} \right\} \right\} \quad (22)$$

The integration for  $\{\bar{A}\}$  and  $\{N_0\}$  at one load,  $\ell$ , is shown as:

$$\bar{A}_\ell = \sqrt{\sum_{i=1}^{NFREQ} \left( \frac{SPEC_{\ell i} + SPEC_{\ell i-1}}{2} \right) (\Omega_i - \Omega_{i-1})} \quad (23)$$

$$N_{0\ell} = \left( \frac{1}{2\pi A_\ell} \right) \sqrt{\sum_{i=1}^{NFREQ} \left( \frac{SPEC_{\ell i} \Omega_i^2 + SPEC_{\ell i-1} \Omega_{i-1}^2}{2} \right) (\Omega_i - \Omega_{i-1})} \quad (24)$$

where  $SPEC_{\ell i}$  is the output spectrum calculated for load  $\ell$  at frequency  $i$  and is found by:

$$SPEC_{\ell i} = \phi(\Omega_i) * |\overline{SUMC}_{\ell i}|^2 \quad (25)$$

where  $|\overline{SUMC}_{\ell i}|$  is the absolute value of the complex number  $\overline{SUMC}_{\ell i}$ .

The input spectrum value  $\phi(\Omega)$  is found by the user's choice of one of the three following equations:

$$\phi(\Omega) = \frac{L}{\pi} \frac{1 + 3(L\Omega)^2}{[1 + (L\Omega)^2]^2} \text{ Dryden} \quad (26)$$

$$\phi(\Omega) = \frac{L}{\pi} \frac{1 + 8/3(1.339L\Omega)^2}{[1 + (1.339L\Omega)^2]^{\frac{11}{6}}} \text{ Von Karman} \quad (27)$$

$$\phi(\Omega) = \kappa(\Omega)^{-n} \text{ Exponential} \quad (28)$$

or by interpolation over a user-supplied tabular spectrum.

7. Print  $\{\bar{A}\}$  and  $\{N_0\}$  and optionally punch them on cards.
8. Check the correlation between the different load responses requested by card input data; optional.

Note: Optionally, the input matrices  $[\bar{M}_4]$ ,  $[\bar{M}_5]$ ,  $[\bar{M}_6]$ ,  $\{\bar{C}_3\}$  or  $\{\bar{\phi}\}$  are frequency dependent. Interpolation is required to define these matrices at each frequency before calculating  $[\text{SUMM}]$ ,  $\{\text{SUMC}\}$ , etc., in step 6.

Optionally, the user may specify multiple forcing functions causing the matrices  $\{\bar{C}_3\}$  and  $\{\text{SUMC}\}$  to be rectangular. (See appendix C for a discussion of the multiple forcing function option.)

Optionally, the user may specify certain degrees of freedom to be deleted. This is accomplished by zeroing the appropriate degrees of freedom in the  $[\text{SUMM}]$  matrix.

9. Modify the load equations for a static-elastic solution; set chosen columns of  $[\bar{M}_2]$ ,  $[\bar{M}_3]$ ,  $[\bar{M}_5]$  and  $[\bar{M}_6]$  to zero; and repeat steps 6, 7, and 8; optional.
10. For additional sets of load equations, repeat steps 5 through 9; optional.

### 5.3 PROGRAM SORTQLS

Program SORTQLS, overlay (L221,2,0), which sorts generalized coordinate and load responses, is called to process data written on the magnetic file "IPLTPE" by program FINDRMS and to write an output magnetic file "NEWTPE" which contains pairs of matrices, independent and dependent variables, to be plotted by a subsequent program.

"IPLTPE" contains one file of data (see fig. 11) for each FINDRMS solution. Each file begins with the frequency array  $\{\text{FREQ}\}$ , a  $1 \times \text{NFREQ}$  matrix, and is followed by NFREQ groups of the three or four arrays below.  $\{\bar{A}\}$  will be present only if IPLRMS = 1 on FINDRMS card 4.3.

## 6.0 COMPUTER PROGRAM USAGE

The program was designed for use on the CDC 6600. The machine requirements to execute L221 (TEV156) are:

Card reader	Read control cards and card input data.
Printer	Print standard output information, optional intermediate calculations, and diagnostic messages.
Disk storage	All magnetic files not specifically defined as magnetic tapes are assumed to be disk files.
Tape drive	For permanent storage of data. Magnetic files are copied to and from magnetic tapes with control cards before and after program execution.
Card punch	Punch the final $\bar{A}$ values and number of zero crossings; optional.

Program L221 (TEV156) is written in FORTRAN and may be compiled with either the RUN or FTN compiler. L221 (TEV156) may be executed on either the KRONOS 2.1 or NOS operating system.

### 6.1 CONTROL CARDS

The following list is a typical set of control cards used to execute L221 (TEV156) using the absolute binaries from the program's master tape.

Job Card	
Account Card	
•	
•	
•	
REQUEST (MASTER,F=I,LB=KL,VSN=66XXXX)	{ Retrieve the program from its master tape
REWIND (MASTER)	
SKIPF (MASTER)	
COPYBF (MASTER,L221)	
RETURN (MASTER)	
•	{ Prepare optional input data files
•	
•	
L221.	{ Execute L221 (TEV156)
•	{ Save optional output data files
•	
•	
EXIT.	

DMP (0,field length)

---End-of-record

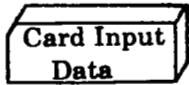

---End-of-file

The following list is a typical set of control cards used to execute L221 (TEV156) using the relocatable binaries from the program's master tape.

Job Card

Account Card

•  
•  
•

REQUEST (MASTER,F=I,LB=KL,VSN=66XXXX)

REWIND (MASTER)

SKIPF (MASTER,2)

COPYBF (MASTER,REL221)

RETURN (MASTER)

•  
•  
•

LDSET (LIB=DYLIB,PRESET=INDEF)

LOAD (REL221)

NOGO.

RETURN (REL221,DYLIB)

L221.

•  
•  
•

EXIT.

DMP (0,field length)

---End-of-record

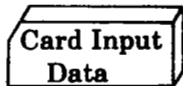

---End-of-file

{ Retrieve the program  
from its master tape

{ Prepare optional  
input files and  
retrieve DYLIB, the  
DYLOFLEX alternate  
subroutine library

{ Load and execute  
L221 (TEV156)

{ Save optional output  
data files

## 6.2 RESOURCE ESTIMATES

The computer resources used (core requirements, tapes, printed output, time, etc.) are functions of the problem size and program options used. Table 1 contains examples of the resources used for a number of sample problems.

Table 1.—Resources Used by Sample Problems

	SAMPLE PROBLEMS				
	1	2	3	4	5
NDOF	7	7	7	8	7
NFREQ	10	10	10	210	72
NFORC	0	0	0	0	6
NKVAL	0	0	10	20	0
NLD	6	6,9*	6	8	7
CPU Seconds	2	25	2	15	10
Disk Requests	100	450	80	310	350
Disk Sectors	830	3500	350	1300	1800
Lines Printed	800	2000	200	2400	3300
Required Core: (Octal)	122000	122000	122000	123000	125000
FINDRMS					124000
SORTQLS		43000			
PLOTQLS		66000			

\* The problem has two load sets.

## Field Length

The field length required by L221 (TEV156) is dependent on the problem size and the program module(s) used. Core must be requested for the largest module to be run: either FINDRMS, SORTQLS, or PLOTQLS. The default maximum core size established in L221 (TEV156) is 200000 octal.

$$\text{Field length} = \text{FLp} + \text{FLm}$$

where FLp is the program length, and FLm is the matrix storage required.

The module(s) have the following octal values of FLp:

FINDRMS	125000
PLOTQLS	66000
SORTQLS	60000

For FINDRMS, the computed value of FLm is the larger of FLq or FLℓ.

FLq = Core required for equations of motion

$$\begin{aligned} &= \text{NFREQ} \\ &+ \text{NDQF}(8 (\text{NFORC}) + 3) \\ &+ \text{NDOF}^2(\text{NMi} + 2) \\ &+ \text{NDOF}; \text{ if static elastic} \\ &+ \text{NDOFD}; \text{ if deletion of freedoms} \\ &+ \text{NDOF}(2 (\text{NPAN})) + \text{NPAN}; \text{ if gradual penetration} \\ &+ \text{NDOF}^2(\text{NSi}) + 3(\text{NDOF}); \text{ if feedback} \\ &+ \text{NDOF}^2(4 (\text{NFORC}) + 6) + \text{NKVAL}; \text{ if NKVAL} > 1 \\ &+ \text{NDOF}(4 (\text{NPAN})); \text{ if NKVAL} > 1 \text{ and gradual penetration} \end{aligned}$$

FLℓ = Core required for load equations

$$\begin{aligned} &= \text{NFREQ} + 3(\text{NDOF}) \\ &+ 3(\text{NLD}) \\ &+ \text{NLD}(\text{NDOF})(\overline{\text{NMi}} + 2) \end{aligned}$$

+ NLD(6 (NFORC))  
 + NFORC(NFORC + 1)  
 + NDOF; if static elastic  
 + NDOFD; if deletion of freedoms  
 + 32(ICORR); if correlation  
 + NPAN(2 (NLD) + 1); if gradual penetration  
 + NLD(NDOF)(NSi) + 3(NDOF); if feedback  
 + NLD(6 (NDOF) + 2(NFORC) + NKVAL); if NKVAL > 1  
 + NLD(4 (NPAN)); if NKVAL > 1 and gradual penetration

For SORTQLS, the computed value of FLm is:

$$FLm = NFREQ*(NR + 1) + NFREQ*NR; \text{ if pairing is to take place}$$

where NR is the larger of NDOF or NLD.

For PLOTQLS, the computed value of FLm is the same as for SORTQLS.

Note: FLm for FINDRMS, SORTQLS, and PLOTQLS must be converted to an octal base number before being added to FLp to find the required field length.

#### Time Estimate

The following factors will be used to calculate the CPU time in seconds for L221 (TEV156), FINDRMS, SORTQLS, and PLOTQLS.

- a = 1; if IPLTPE = 0  
= 1.2; if IPLTPE > 0
- b = 1; if ISTATE = 0  
= 2; if ISTATE > 0
- c = 1; if IPRINT = 0  
= 1.5; if IPRINT > 0
- d = 1; if IFDBAK = 0  
= 1.2; if IFDBAK > 0

$$CP_{FINDRMS} = \left[ (b*c*d) * \frac{NFREQ*NDOF^2}{1000} \right] + \left[ \frac{(a*b*c*d)}{3000} * \sum_{i=1}^{NSETS} NFREQ*(NLD_i*NDOF) \right]$$

$CP_{SORTQLS}$  = 1 second per item sorted

$CP_{PLOTQLS}$  = 1 second per item plotted

$CP_{L221}$  = 10. +  $CP_{FINDRMS}$  +  $CP_{SORTQLS}$  +  $CP_{PLOTQLS}$

### Printed Output

The printed output line limit has been set to 100000 lines which should be enough for any L221 (TEV156) execution.

### Punched Output

When punched output is requested (IPUNCH = 1 on card 4.3 of FINDRMS), the number of cards punched will be

$$\frac{2}{7} * \sum_{i=1}^{NSETS} NLD_i$$

where:

NSETS = Number of load sets

NLD<sub>i</sub> = Number of loads in set i

### 6.3 CARD INPUT DATA

The card input described in sections 6.3.2 to 6.3.5 is summarized in section 6.3.6. The summary is a quick reference for the necessary card input and is included for use only after familiarity with the program has been obtained.

The task(s) performed by L221 (TEV156) are broken into three subtasks, each with its own section of code known as a primary overlay. The entire set of primary overlays is driven by a small program (main overlay) named L221.

L221 reads program directive cards to:

- Assure that the data being read is intended for L221 (TEV156)



- Determine which section of code (primary overlay) of L221 is to be executed next

Each primary overlay has its own card input data sets. The primary overlays and data set numbers are listed in table 2.

Table 2.—Primary Overlays and Data Set Numbers

Overlay		Data sets	Purpose of primary overlay
Number	Name		
1	FINDRMS	2 through 49	Calculate the generalized coordinates and loads over a range of frequencies and find the RMS values of loads, $\bar{A}$ , and the number of zero crossings, $N_o$ .
2	SORTQLS	50 through 61	Sort data generated by FINDRMS and write a magnetic file containing the data in vectors (frequency dependent) suitable for plotting.
3	PLOTQLS	62 through 79	Sort data generated by FINDRMS and write a magnetic file containing plot instructions and data for the COMp80 plotter.

The order in which these card sets are input (and the overlays are executed) is displayed in figure 2.

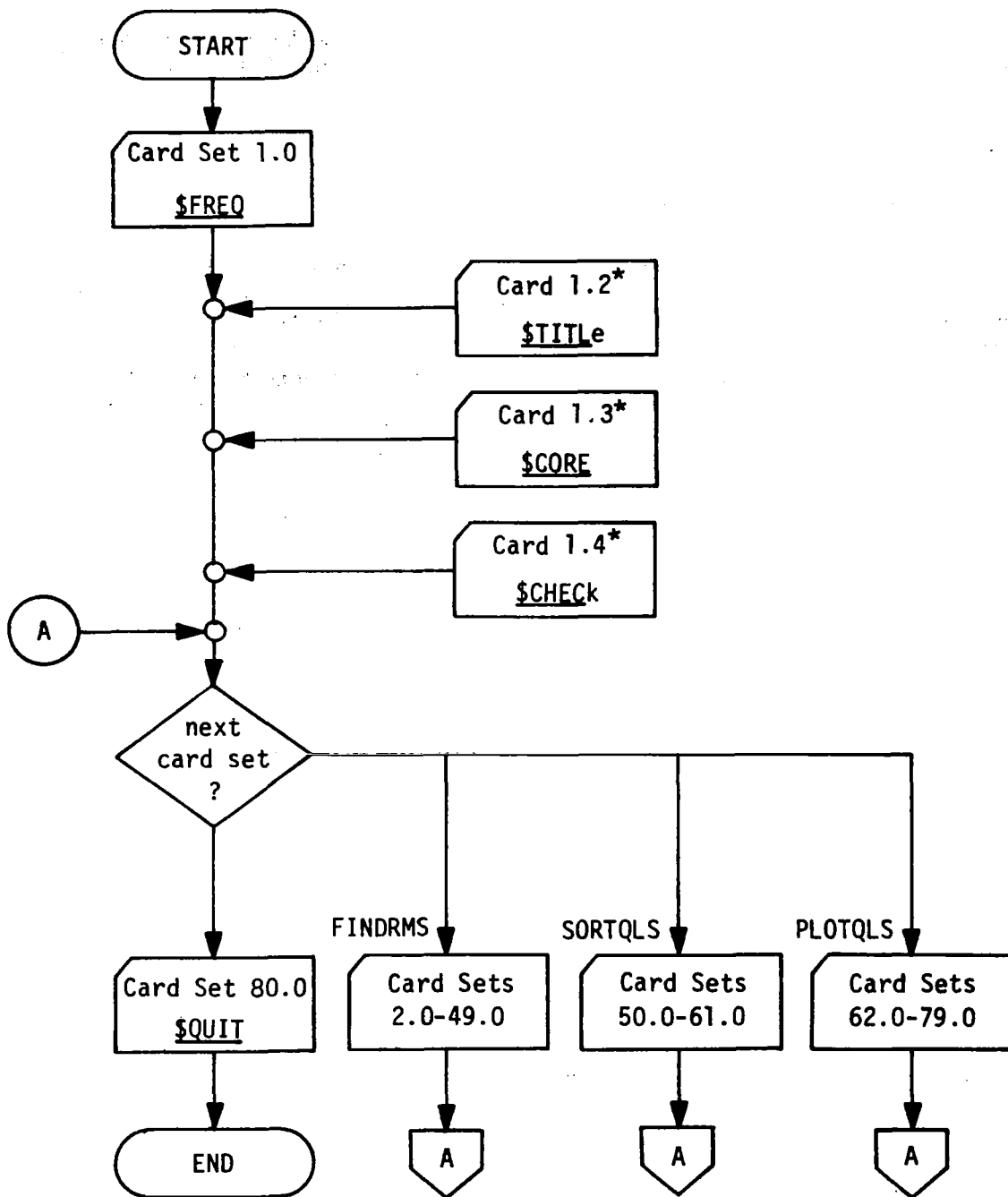

\* Optional

Figure 2.—Flow of L221 (TEV156) Card Input Data

### **6.3.1 FORMAT OF CARD INPUT DATA**

All card data are read in fixed fields—specific columns of the cards. The required card columns are defined next to each keyword or variable on the pages that follow. Note the following conventions used throughout the program:

- All floating point variables are read with format E10.0
- All integer variables are read with format I5.
- All hollerith variables (keywords, etc.) are read with format A10.

Therefore, all data fields end on a card column which is a multiple of five.

When the program is trying to recognize keywords, it checks only the first five characters. Any additional characters are ignored.

## Format of Matrices Input on Cards

Matrices are read from cards by rows (each row begins on a new card) with the format 7E10.0. When a matrix contains only one column, the transpose of the matrix is read from cards.

Example:

If  $[M_1]$  is to be input as a 9 by 9 matrix, 18 cards will be needed.

$M_1(1,1)$	$M_1(1,2)$	$\dots$	$M_1(1,7)$	$\text{Card 1}$
1	10	20	60	70

$M_1(1,8)$	$M_1(1,9)$	$\dots$		$\text{Card 2}$
1	10	20		70

$M_1(2,1)$	$M_1(2,2)$	$\dots$	$M_1(2,7)$	$\text{Card 3}$
1	10	20	60	70

$M_1(2,8)$	$M_1(2,9)$	$\dots$		$\text{Card 4}$
1	10	20		70

⋮

$M_1(9,1)$	$M_1(9,2)$	$\dots$	$M_1(9,7)$	$\text{Card 17}$
1	10	20	60	70

$M_1(9,8)$	$M_1(9,9)$	$\dots$		$\text{Card 18}$
1	10	20		70

### 6.3.2 PROGRAM L221

The driving module of L221 (TEV156) (the main overlay is known as L221) will read and check the first five characters of the input card to determine the type of execution that is to take place.

Note: All underlined capital characters contained in the KEYWORD/VARIABLE field of the input card sets must be left justified and punched in the card columns specified in the COLS. field of the input card sets.

#### Card Set 1.0--Introduce L221 (TEV156) Card Input Data

##### Card 1.1--Frequency Response Card

COLS.	KEYWORD/ VARIABLE	FORMAT	DESCRIPTION
1-10	<u>\$FRE</u> quency	A10	This card <u>must</u> be the first card read by L221 (TEV156). It signifies that the input card data is to be used by L221 (TEV156) for a Frequency Response Analysis.
11-70			Available for comments.

##### Card 1.2--Title Card

COLS.	KEYWORD/ VARIABLE	FORMAT	DESCRIPTION
1-10	<u>\$TITL</u> e	A10	A title card that is intended to label the program's printed output with miscellaneous titling information.  After this card is read and printed, control is returned to the main overlay for the reading of the next instructional keyword card.  The number of \$TITL cards is unlimited.
11-70			Available for comments.

##### Card 1.3--Core Card

COLS.	KEYWORD/ VARIABLE	FORMAT	DESCRIPTION
1-10	<u>\$COR</u> E	A10	A keyword designating a card which sets the maximum field length to be used by L221 (TEV156).
11-20	MAXCOR	010	The maximum field length, in octal, which L221 (TEV156) may use.  Default: 200000 <sub>8</sub>
21-70			Available for comments.

### Card 1.4—Special Programmer Checkout Option

COLS.	KEYWORD/ VARIABLE	FORMAT	DESCRIPTION
1-10	<u>\$CHECK</u>	A10	This card is used as an aid in the checkout of fatal error diagnostics. This option will allow L221 (TEV156) to continue execution even after a fatal error has been diagnosed.
11-70			Available for comments.

To use this option, the programmer must use the following card sets:

Card 1.1            \$FREQuency  
Card 1.4            \$CHECk

·  
·  
·  
Any card sets the programmer wishes to be tested.  
·  
·  
·

Card set 80.0        \$QUIT

### 6.3.3 PROGRAM FINDRMS

The card input data for FINDRMS are divided into three main blocks:

- BLOCK I**            Options and constant data
- BLOCK II**        Instructions and matrices needed to calculate the generalized coordinates frequency response
- BLOCK III**        Instructions and matrices needed to calculate the loads frequency response

The three blocks are always in this order, although BLOCK III may be repeated as many as 10 times. BLOCK I is to be input on cards, but the main parts of BLOCKS II and III—the matrices—may be input on cards or on the magnetic files "INTAPE" and "LDTAPE".

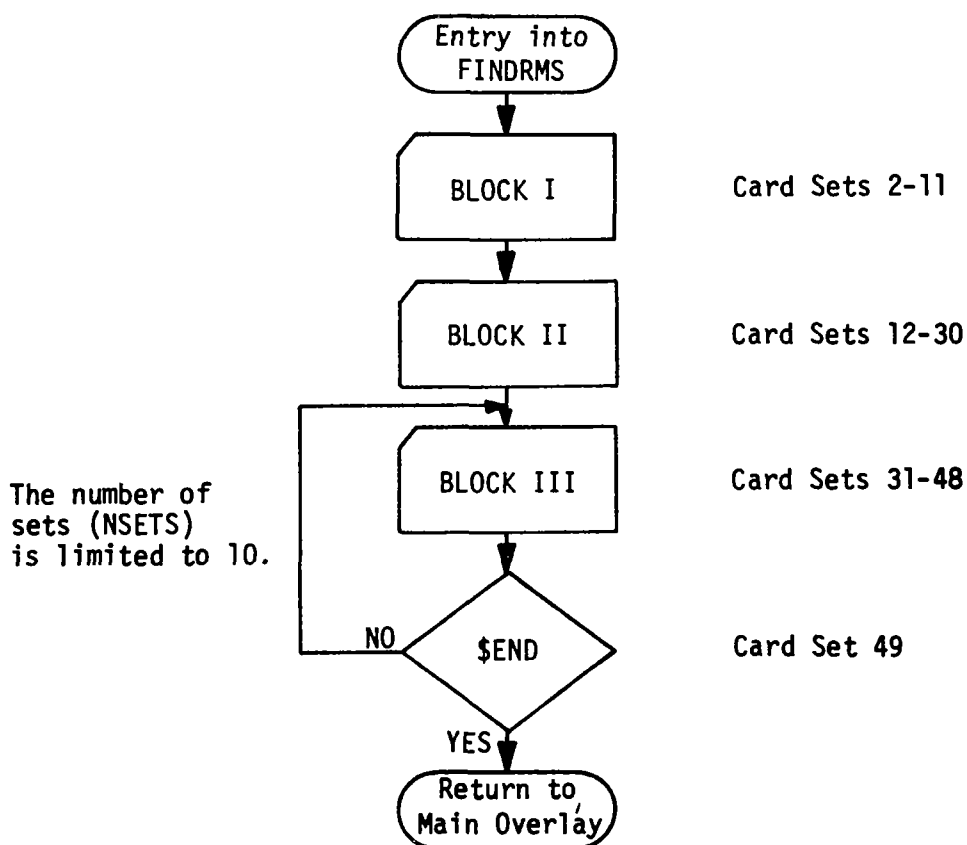

#### BLOCK I—Options and Constant Data

The \$FINDRMS card (card set 2.0) introduces BLOCK I, card input data defining the necessary options and constants. The flow of BLOCK I data cards is displayed in figure 3.

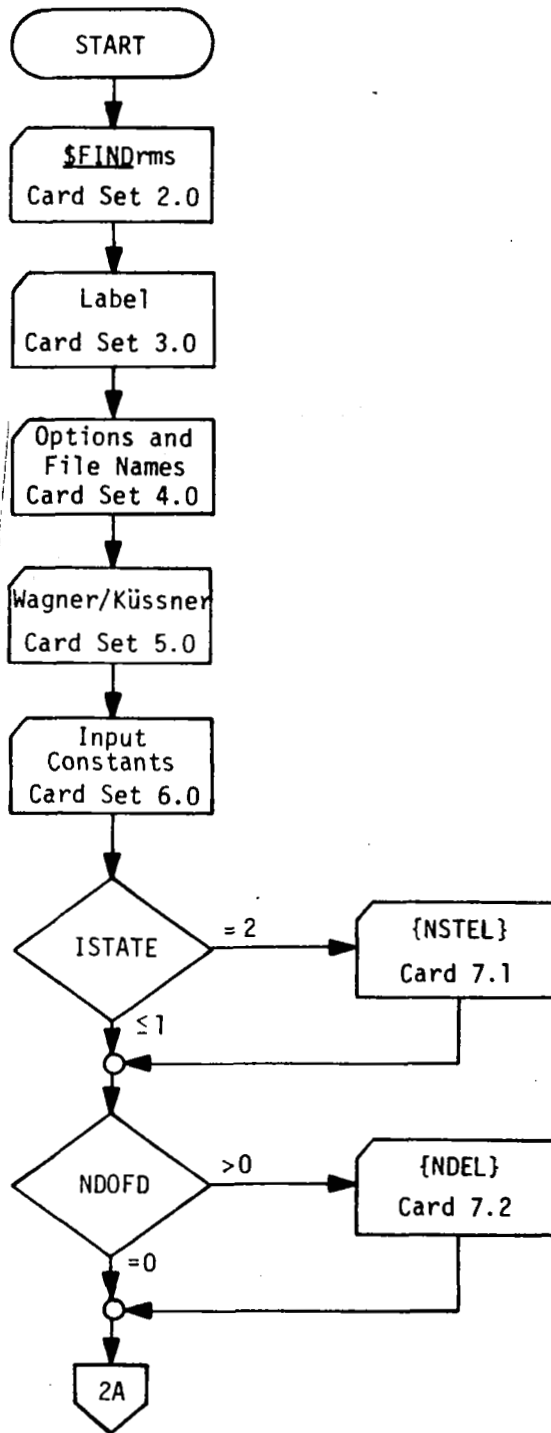

Figure 3.—Flow of FINDRMS Block 1 Card Input Data



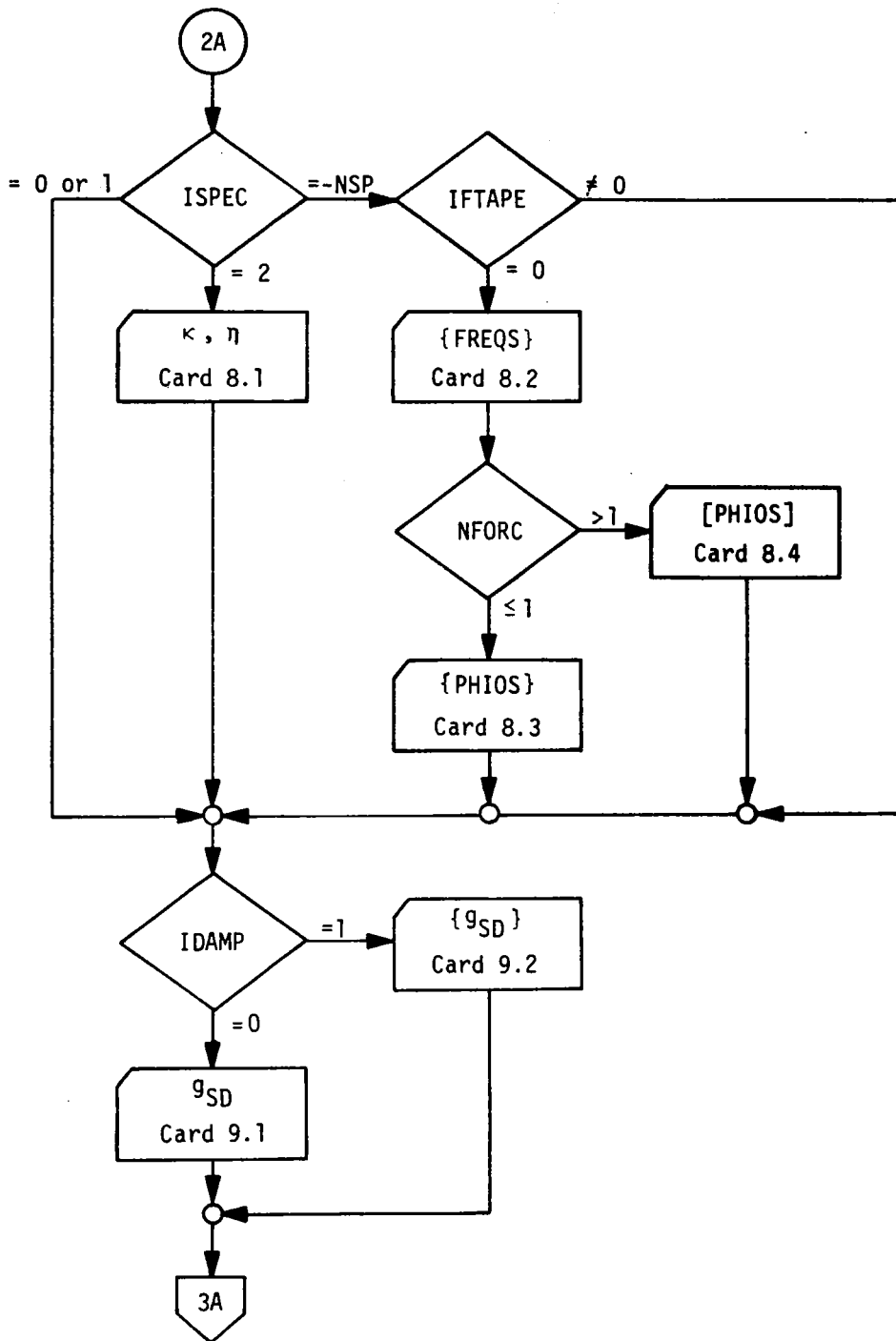

Figure 3.—(Continued)

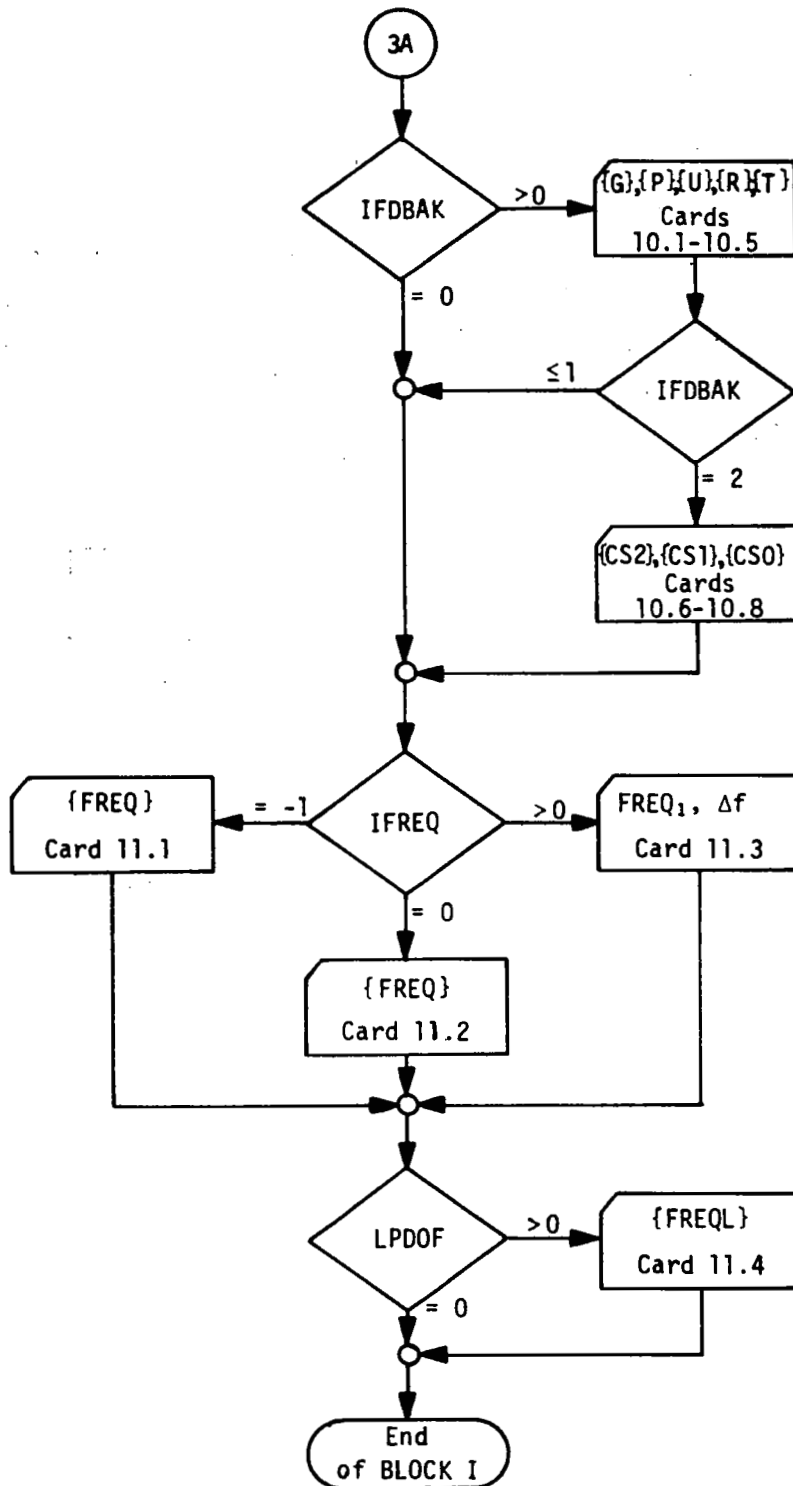

Figure 3.—(Concluded)

### Card Set 2.0-Call Card for FINDRMS

COLS.	KEYWORD/ VARIABLE	FORMAT	DESCRIPTION
1-10	<u>\$FIND</u> rms	A10	This Card Set initializes the call to the primary overlay, FINDRMS. FINDRMS will read Card Sets 3-49 and perform the necessary calculations. Control will be returned to the main overlay, L221 upon the reading of Card Set 49.
11-70			Available for comments.

### Card Set 3.0-Label Card

COLS.	KEYWORD/ VARIABLE	FORMAT	DESCRIPTION
1-70	LABEL	7A10	A one card data case label which is printed above the resulting output.

## Card Set 4.0-Options and File Names

### Card 4.1-Problem Size

COLS.	KEYWORD/ VARIABLE	FORMAT	DESCRIPTION
1-5	NDOF	I5	The number of degrees of freedom, i.e. the number of generalized coordinates or equations of motion. $(0 < \text{NDOF} \leq 100)$
6-10	NFREQ	I5	The number of frequencies over which the solution will be found. $(\text{NFREQ} > 2)$
11-15	NPAN	I5	The number of panels for gradual penetration. If the gradual penetration option is <u>not</u> desired NPAN must be set to zero. When using DYLOFLEX tapes for "INTAPE" and/or "LDTAPE" the number panels must be $\geq 1$ because gradual penetration is always assumed in DYLOFLX, thus no $\{C_3\}$ . $(0 \leq \text{NPAN} \leq 100)$
16-20	NKVAL	I5	The number of k-values used in an unsteady aerodynamic analysis. If NKVAL is greater than zero, matrices will be read at the defined frequencies (Card Set 17) and interpolation will occur to find the matrices at the solution frequencies. $\{C_3\}$ or $[\phi]$ are complex with $\text{NKVAL} > 0$ . When $\text{NKVAL} = 0$ all input matrices are real. When using DYLOFLEX tapes for "INTAPE" and/or "LDTAPE" the number of k values must be $\geq 1$ . $(\text{NKVAL} \geq 0)$ Default: 0

21-25	NFORC	I5	<p>The number of excitation forces for the handling of multiple forcing functions (see Appendix C).</p> <p>Note: If more than one excitation force is being used the following limitations are imposed:</p> <ul style="list-style-type: none"> <li>• NPAN = 0.</li> <li>• no feedback.</li> <li>• no loads correlation.</li> <li>• the frequency responses and load transfer functions may be plotted for only the first excitation forces.</li> <li>• <math>\{C_2\}</math> and <math>\{\bar{C}_2\}</math> are null.</li> <li>• the loads per degree of freedom can <u>not</u> be printed.</li> </ul> <p>(NFORC <math>\geq</math> 1)</p> <p>Default: 1</p>
26-30	NDOFD	I5	<p>The number of degrees of freedom to be deleted.</p> <p>Note: See Card 7.2 for the input of the degrees of freedom to be deleted.</p> <p>(NDOFD &lt; NDOF)</p>

### Card 4.2-Optional Capabilities

COLS.	KEYWORD/ VARIABLE	FORMAT	DESCRIPTION
1-5	IFREQ	I5	<p>This option chooses the type of frequency matrix input.</p> <ul style="list-style-type: none"> <li>= -1 The frequencies will be read from cards in cycles per second, (see Card 11.1).</li> <li>= 0 The frequencies will be read from cards in radians per second, (see Card 11.2).</li> <li>= 1,2,3,4,5 The frequency matrix will be generated according to Appendix A, using an initial frequency, <math>FREQ_1</math>, and an increment DELTAF in cycles per second, (see Card 11.3).</li> </ul>
6-10	ISPEC	I5	<p>This option specifies the type of input spectrum to be used, (<math>\Omega</math> is in radians per unit distance).</p> <ul style="list-style-type: none"> <li>= 0 Dryden           <math display="block">\phi(\Omega) = \frac{L}{\pi} \frac{1 + 3(L\Omega)^2}{[1 + (L\Omega)^2]^2}</math> </li> <li>= 1 Von Karman           <math display="block">\phi(\Omega) = \frac{L}{\pi} \frac{1 + 8/3(1.339L\Omega)^2}{[1 + (1.339L\Omega)^2]^{11/6}}</math> </li> <li>= 2 Exponential           <math display="block">\phi(\Omega) = \kappa (\Omega)^{-n}</math> <p>Note: See card Set 6 for L and Card 8.1 for <math>\kappa</math> and n.</p> </li> <li>= -NSP           <p>A tabular input spectrum defined at NSP points (see Cards 8.2, 8.3, and 8.4).</p> </li> </ul>
11-15	ISTATE	I5	<p>This option requests a static-elastic solution.</p> <ul style="list-style-type: none"> <li>= 0 <u>No</u> static-elastic solution.</li> <li>= 1 A static-elastic solution will be found after zeroing columns 3 through NDOF of <math>[M_2]</math>, <math>[M_3]</math>, <math>[M_5]</math>, <math>[M_6]</math>, <math>[\bar{M}_2]</math>, <math>[\bar{M}_3]</math>, <math>[\bar{M}_5]</math>, and <math>[\bar{M}_6]</math>, implying that the rigid body degrees of freedom are in columns 1 and 2.</li> <li>= 2 A static-elastic solution will be found, by zeroing columns of matrices <math>[M_2]</math>, <math>[M_3]</math>, <math>[M_5]</math>, <math>[M_6]</math>, <math>[\bar{M}_2]</math>, <math>[\bar{M}_3]</math>, <math>[\bar{M}_5]</math>, and <math>[\bar{M}_6]</math> according to Card Set 7.</li> </ul>

16-20	IFDBAK	I5	<p>This option requests that a feedback loop be used.</p> <ul style="list-style-type: none"> <li>= 0 <u>No</u> feedback loop used.</li> <li>= 1 A standard feedback loop will be used.</li> <li>= 2 A special feedback loop will be used, (see RLIMIT of Card 10.1 and Cards 10.6, 10.7, and 10.8). Also, see Appendix B.</li> </ul>
21-25	IDAMP	I5	<p>This option specifies the number of different structural damping factors.</p> <ul style="list-style-type: none"> <li>= 0 The same factor will be used for all freedoms, (see Card 9.1).</li> <li>= 1 A different factor will be used for each frequency, (see Card 9.2).</li> </ul>
26-30	INTZRO	I5	<p>This option chooses the starting point for the RMS integration.</p> <ul style="list-style-type: none"> <li>= 0 The RMS integration will start at zero. The output spectrum is assumed to grow linearly between the frequencies 0 and <math>FREQ_1</math> (from the value 0. to the value calculated at <math>FREQ_1</math>). The area in the resulting triangle is included in the integration.</li> <li>= 1 The RMS integration will start at <math>FREQ_1</math>. The range between frequencies 0 and <math>FREQ_1</math> is ignored.</li> </ul>

### Card 4.3-Output Options

COLS.	KEYWORD/ VARIABLE	FORMAT	DESCRIPTION
1-5	IPRINT	I5	<p>This option chooses the type of printing to take place.</p> <ul style="list-style-type: none"> <li>= 0 Print only the final <math>\bar{A}</math> values and the number of zero crossings.</li> <li>= 1 Print the generalized coordinates and load transfer functions for each frequency as well as the final <math>\bar{A}</math> and number of zero crossings.</li> </ul>
6-10	IRMSPR	I5	<p>This option chooses the type of printing for the <math>\bar{A}</math> values.</p> <ul style="list-style-type: none"> <li>= 0 Print only the final <math>\bar{A}</math> values.</li> <li>&gt; 0 Print the <math>\bar{A}</math> values for each of the last IRMSPR frequencies. (IRMSPR <math>\leq</math> NFREQ)</li> </ul>
11-15	IPUNCH	I5	<p>This option requests that the final <math>\bar{A}</math> values and number of zero crossings be punched on cards.</p> <ul style="list-style-type: none"> <li>= 0 <u>No</u> punched output.</li> <li>= 1 Punch on cards the final <math>\bar{A}</math> values and number of zero crossings.</li> </ul>
16-20	ICKPRT	I5	<p>This option chooses the amount of checkout printout for the problem.</p> <ul style="list-style-type: none"> <li>= 0 The input matrices are <u>not</u> printed.</li> <li>= 1 The input matrices will be printed as read.</li> <li>= 2 The input matrices plus intermediate data for the first three frequencies will be printed.</li> <li>= 5 Special program checkout feature. It prints 1 and 2 above and a record of all VARDIM routines called.</li> </ul>
21-25	IPLRMS	I5	<p>This option requests the writing of final <math>\bar{A}</math> values on the plot data file "IPLTPE"</p> <ul style="list-style-type: none"> <li>= 0 <math>\bar{A}</math> values <u>not</u> saved.</li> <li>= 1 <math>\bar{A}</math> values will be written on "IPLTPE" for each frequency, (see Card 4.4).</li> </ul>



26-30	LPDOF	I5	<p>This option requests the printing of loads per degree of freedom at certain frequencies.</p> <p>= 0 The loads per degree of freedom will <u>not</u> be found.</p> <p>&gt; 0 The loads due to each degree of freedom will be found and printed for the LPDOF frequencies specified on Card 11.4. (LPDOF ≤ 10)</p>
-------	-------	----	---

**Card 4.4-File Names**

**Note:** All magnetic files *not* to be defined must have their appropriate fields left blank.

COLS.	KEYWORD/ VARIABLE	FORMAT	DESCRIPTION
1-10	INTAPE	A10	<p>This option indicates the location of the input matrices.</p> <ul style="list-style-type: none"> <li>- The input matrices will be read from cards if the field is left blank.</li> <li>- The input matrices will be read from a magnetic file in READTP/WRTETP format. The file name must be a left-justified 1 to 7 character name with the first character being alphabetic.</li> </ul>
11-20	IPLTPE	A10	<p>This option indicates whether or not a plotting magnetic file will be created.</p> <ul style="list-style-type: none"> <li>- The plotting information will <u>not</u> be written if the field is left blank.</li> <li>- The plotting information will be written on a magnetic file in REATP/WRTETP format. The magnetic file name must be a left-justified, 1 to 7 character name with the first character being alphabetic.</li> </ul>
21-30	IRTAPE	A10	<p>This option indicates whether or not the generalized coordinates and the load transfer functions will be written on a magnetic file.</p> <ul style="list-style-type: none"> <li>- The generalized coordinates, and the load transfer functions will <u>not</u> be written onto a magnetic file if left blank.</li> <li>- The generalized coordinates, and the load transfer functions will be written on a magnetic file in READTP/WRTETP format. The magnetic file name must be a left-justified, 1 to 7 character name with the first character being alphabetic.</li> </ul>

31-40	IFTAPE	A10	<p>This option indicates the location of the Tabular Input Spectra.</p> <ul style="list-style-type: none"><li>- The Tabular Input Spectra will be read from cards if the field is left blank.</li><li>- The Tabular Input Spectra will be read from a magnetic file in READTP/WRTETP format. The file name must be a left justified 1 to 7 character file name with the first character being alphabetic.</li></ul>
-------	--------	-----	---

## Card Set 5.0-Wagner and Küssner Indicial Lift Growth Function Coefficients

### Card 5.1-Wagner Indicial Lift Growth Coefficients

COLS.	KEYWORD/ VARIABLE	FORMAT	DESCRIPTION
1-10	A <sub>1</sub>	E10.0	The Wagner Function Coefficients.  $g(s) = A_1 - \frac{B_1 s}{s + \alpha_1} - \frac{C_1 s}{s + \beta_1} - \frac{D_1 s}{s + \gamma_1}$ where $s = i\omega$ and $\omega$ is the frequency in radians per second. (See table 3)  Note: When NKVAL > 1 of card 4.1, set A <sub>1</sub> = 1. and all other variables to zero.
11-20	B <sub>1</sub>	E10.0	
21-30	C <sub>1</sub>	E10.0	
31-40	D <sub>1</sub>	E10.0	
41-50	α <sub>1</sub>	E10.0	
51-60	β <sub>1</sub>	E10.0	
61-70	γ <sub>1</sub>	E10.0	

### Card 5.2-Küssner Indicial Lift Growth Function Coefficients

COLS.	KEYWORD/ VARIABLE	FORMAT	DESCRIPTION
1-10	A <sub>2</sub>	E10.0	The Küssner Function Coefficients.  $f(s) = A_2 - \frac{B_2 s}{s + \alpha_2} - \frac{C_2 s}{s + \beta_2} - \frac{D_2 s}{s + \gamma_2}$ where $s = i\omega$ and $\omega$ is the frequency in radians per second. (See table 4)  Note: When NFORC > 1 or NKVAL > 1 set A <sub>2</sub> = 1. and all other variables to zero.
11-20	B <sub>2</sub>	E10.0	
21-30	C <sub>2</sub>	E10.0	
31-40	D <sub>2</sub>	E10.0	
41-50	α <sub>2</sub>	E10.0	
51-60	β <sub>2</sub>	E10.0	
61-70	γ <sub>2</sub>	E10.0	

Tables 3 and 4 list the different values for the Wagner and Küssner functions as functions of aspect ratio, AR, at  $M = 0$ . These values were obtained from reference 3. The user is urged to refer to reference 3 and 4 in order to obtain a greater understanding of the derivation of these indicial functions and the theoretical aspects associated with their derivation.

Table 3.—Coefficients for the Wagner Indicial Lift Growth Function at  $M = 0$

AR	A <sub>1</sub>	B <sub>1</sub>	C <sub>1</sub>	D <sub>1</sub>	α <sub>1</sub>	β <sub>1</sub>	γ <sub>1</sub>
∞	1.0	.185	.335	0	.045	.30	0
6	1.0	.361	0	0	.381	0	0
3	1.0	.283	0	0	.540	0	0

Table 4.—Coefficients for the Küssner Indicial Lift Growth Function at  $M = 0$

AR	A <sub>2</sub>	B <sub>2</sub>	C <sub>2</sub>	D <sub>2</sub>	α <sub>2</sub>	β <sub>2</sub>	γ <sub>2</sub>
∞	1.0	.5	.5	0	.13	1.0	0
6	1.0	.448	.272	.193	.290	.725	-3.0
3	1.0	.679	.227	0	.558	3.20	0

$$\alpha_i = \frac{2V_T}{C} \quad \beta_i = \bar{\beta}_i \cdot \frac{2V_T}{C} \quad \gamma_i = \bar{\gamma}_i \cdot \frac{2V_T}{C}$$

C = some reference chord

i = 1 or 2

### Card Set 6.0-Input Constant

COLS.	KEYWORD/ VARIABLE	FORMAT	DESCRIPTION
1-10	Z	E10.0	The scalar constant for the equations of motion and loads equation convoluted forcing function coefficient matrices, (e.g. $\{C_3\}$ and $\{C_3\}$ ). In DYLOFLX, Z must be input as a negative number to obtain sign compatibility for the gust forcing function generated in L217(EOM) and L213(LDADS) (Z $\neq$ 0)
11-20	VEL	E10.0	The velocity (true airspeed) of the frequencies are converted to radians per unit distance by the following conversion: $\Omega = \frac{\omega}{VEL}$ where $\Omega$ is in radians/distance and $\omega$ is in radians per second. $\Omega$ is used to determine the input spectrum.* (VEL > 0)
21-30	L (TSCALE)	E10.0	The turbulence scalar constant. It is required when ISPEC of Card 4.2 is equal to 0 or 1. (See eqn 26 and eqn 27 of Section 5.0 for the Dryden and Von Karman input spectra). Note: The unit distance must be in the same units described in VEL above. (L > 0)
31-40	C (GPSCAL)	E10.0	The gradual penetration scalar constant. (See eqn 19 of Section 5.0 for the calculation of gradual penetration). Note: This variable is needed only when gradual penetration is requested. (C > 0)
41-50	TABFS	E10.0	The scaling factor for the frequencies at which the Tabular Input Spectra are defined. (See Card 8.2). (Default = 1)

\*For DYLOFLEX when gradual penetration is used, the length unit of VEL must be the same as the f units of length established in L217 (EOM).

51-60	TABS	E10.0	<p>The scaling factor for the Tabular Input Spectra. (See Card 8.3 or 8.4). (Default = 1)</p>
61-70	FDSCAL	E10.0	<p>The scalar constant for the frequencies contained in {FREQM}, the array of frequencies at which input matrices are defined. This scalar can be used only when NKVAL of Card 4.1 is greater than zero.</p> <p>Note: If the frequencies are to be read in as radians/second, and {FREQM} is in cycles/second, then FDSCAL must = 6.2831853, (which is <math>2\pi</math>).</p> <p>If the frequencies are to be read in as cycles/second, and {FREQM} is in radians/second, then FDSCAL must = <math>1/6.2831853</math>, (which is <math>1/2\pi</math>).</p> <p>(Default = 1)</p>

## Card Set 7.0-Deletion of Degrees of Freedom

### Card 7.1-Deletion of Freedoms for a Static-Elastic Solution

Omit card 7.1 if ISTATE  $\leq$  1 on card 4.2.

COLS.	KEYWORD/ VARIABLE	FORMAT	DESCRIPTION
1-5	NSTEL <sub>1</sub>	14I5	<p>NSTEL<sub>i</sub>, i = 1, NDOF where NDOF (Card 4.1) is the number of degrees of freedom.</p> <p>NSTEL chooses the columns to be zeroed in the matrices [M<sub>2</sub>], [M<sub>3</sub>], [M<sub>5</sub>], [M<sub>6</sub>], [M̄<sub>2</sub>], [M̄<sub>3</sub>], [M̄<sub>5</sub>], and [M̄<sub>6</sub>] when performing a static-elastic solution.</p> <p>If NSTEL<sub>i</sub> = 0, then column i of the above matrices will be zeroed.</p>
6-10	NSTEL <sub>2</sub>		
⋮	⋮		
	NSTEL <sub>NDOF</sub>		

### Card 7.2-Deletion of Degrees of Freedom

Omit card 7.2 if NDOFD = 0 on card 4.1.

COLS.	KEYWORD/ VARIABLE	FORMAT	DESCRIPTION
1-5	NDEL <sub>1</sub>	14I5	<p>NDEL<sub>i</sub>, i = 1, NDOFD where NDOFD (Card 4.1) is the number of degrees of freedom to be deleted.</p> <p>NDEL<sub>i</sub> is the specified degree of freedom to be deleted. (NDEL<sub>i</sub> <math>\leq</math> NDOF)</p> <p>For the generalized coordinates, the degrees of freedom will be deleted by zeroing the appropriate rows and columns of [SUMM] and the rows of {SUMC}. Also, the diagonal elements of the appropriate rows of [SUMM] will be set equal to 1.</p> <p>In the loads solution the degrees of freedom will be deleted by zeroing the appropriate columns of [SUMM].</p>
6-10	NDEL <sub>2</sub>		
11-15	NDEL <sub>3</sub>		
⋮	⋮		
	NDEL <sub>NDOFD</sub>	Repeat the card with 14 numbers per card until all elements are defined.	

### Card Set 8.0-Input Power Spectra

Omit card set 8.0 if ISPEC = 0 or 1 on card 4.2.

#### Card 8.1-Exponential Power Spectrum Input

Read card 8.1 if ISPEC = 2 on card 4.2.

COLS.	KEYWORD/ VARIABLE	FORMAT	DESCRIPTION
1-10	K (OCEOEF)	E10.0	The input power spectrum coefficients. $\phi(\Omega) = \kappa(\Omega)^{-\eta}$
11-20	$\eta$ (OEX)	E10.0	(See eqn 28 of Section 5.0 for the exponential input spectrum).

#### Card 8.2-Frequencies of the Tabular Input Spectrum

Omit card 8.2 if ISPEC  $\geq$  0 on card 4.2 or if IFTAPE of card 4.4 is defined.

COLS.	KEYWORD/ VARIABLE	FORMAT	DESCRIPTION
1-10	FREQS <sub>1</sub>	7E10.0	FREQS <sub>i</sub> , i = 1, NSP where NSP of Card 4.2 is the value for the Tabular Input Spectrum.  The Tabular Input Spectrum Frequencies in cycles per seconds.
11-20	FREQS <sub>2</sub>		
⋮	⋮		
	FREQS <sub>NSP</sub>		
			Repeat the card with 7 numbers per card until all elements are defined.

FREQS<sub>i</sub> are the frequencies at which the tabular input spectra are defined. The frequencies must cover the range of solution frequencies defined in card set 11.0 and be defined in the same units. The scalar TABFS of card set 6.0 may be used to provide compatibility. L221 (TEV156) will not extrapolate.

### Card 8.3—Single Tabular Input Spectrum

Omit card 8.3 if  $ISPEC \geq 0$  on card 4.2, or if  $NFORC > 1$  on card 4.1, or if IFTAPE of card 4.4 is defined.

COLS.	KEYWORD/ VARIABLE	FORMAT	DESCRIPTION
1-10	$PHIOS_1$	7E10.0	$PHIOS_i$ ; $i = 1, NSP$
11-20	$PHIOS_2$		The value of the tabular input spectrum at $FREQS_i$ ; $i = 1, NSP$
:	:		where $NSP =  ISPEC $ from Card 4.2.
	$PHIOS_{NSP}$		Repeat the card with 7 numbers per card until all elements are defined.

$PHIOS_i$  is a real number (no imaginary part). The scalar TABS in card set 6.0 may be used to modify the units. The program will interpolate to find the spectrum value at solution frequencies.



### Card 8.4—Multiple Tabular Input Spectrum

Omit card 8.4 if  $ISPEC \geq 0$  on card 4.2, or if  $NFORC \leq 1$  on card 4.1, or if IFTAPE of card 4.4 is defined.

Card 8.4 must be repeated for all combinations of (I,J) where  $I = 1, NFORC$  and  $J = I, NFORC$ . Because of symmetry, only the upper right triangular combinations are input. Input row 1 first ( $J = 1, NFORC$ ), then row 2 ( $J = 2, NFORC$ ), . . . , and, finally, row  $NFORC$  ( $J = NFORC$ ).

COLS.	KEYWORD/ VARIABLE	FORMAT	DESCRIPTION
1-10	$PHIOS(I,J)_1$ (real)	7E10.0	$PHIOS(I,J)_k; k = 1, NSP$  The value of the (I,J) tabular input spectrum at $FREQS_k$ ; $k = 1, NSP$ where $NSP =  ISPEC $ from Card 4.2.  Note that each element is a complex number with real and imaginary parts.
11-20	$PHIOS(I,J)_1$ (imaginary)		
21-30	$PHIOS(I,J)_2$ (real)		
31-40	$PHIOS(I,J)_2$ (imaginary)		
⋮	⋮		
	$PHIOS(I,J)_{NSP}$ (real)		Repeat the card with 7 numbers per card until all elements are defined.
	$PHIOS(I,J)_{NSP}$ (imaginary)		

**Card Set 9.0-Structural Damping**

**Card 9.1-Same Damping Factor for All Freedoms**

Read card 9.1 if IDAMP = 0 on card 4.2.

COLS.	KEYWORD/ VARIABLE	FORMAT	DESCRIPTION
1-10	$g_{SD_1}$	E10.0	A structural damping factor used for all degrees of freedom.

**Card 9.2-Different Damping Factors for Each Freedom**

Read card 9.2 if IDAMP = 1 on card 4.2.

COLS.	KEYWORD/ VARIABLE	FORMAT	DESCRIPTION
1-10	$g_{SD_1}$	7E10.0	$g_{SD_i}$ , $i = 1, NDOF$ where NDOF of Card 4.2 is the number of degrees of freedom. The structural damping factor for each degree of freedom.
11-20	$g_{SD_2}$		
⋮	⋮		
	$g_{SD_{NDOF}}$		

### Card Set 10.0-Feedback Coefficients

Omit card set 10.0 if IFDBAK = 0 on card 4.2.

#### Card 10.1-Standard Feedback Coefficients

COLS.	KEYWORD/ VARIABLE	FORMAT	DESCRIPTION
1-10	G	E10.0	Coefficient of the feedback transfer function, FYDAMP, (see the equation below).
11-20	RLIMIT	E10.0	The rudder limiting angle in radians. This variable is needed only when IFDBAK of Card 4.2 is equal to 2.

#### Card 10.2-Standard Feedback Coefficients

COLS.	KEYWORD/ VARIABLE	FORMAT	DESCRIPTION
1-10	$P_1$	7E10.0	$P_i, i = 1,7$  Coefficient of the feedback transfer function, FYDAMP, (see the equation below).
11-20	$P_2$		
•	•		
61-70	$P_7$		

#### Card 10.3-Standard Feedback Coefficients

COLS.	KEYWORD/ VARIABLE	FORMAT	DESCRIPTION
1-10	$U_1$	7E10.0	$U_i, i = 1,7$  Coefficient of the feedback transfer function, FYDAMP, (see the equation below).
11-20	$U_2$		
•	•		
61-70	$U_7$		

### Card 10.4-Standard Feedback Coefficients

COLS.	KEYWORD/ VARIABLE	FORMAT	DESCRIPTION
1-10	R <sub>1</sub>	7E10.0	$R_i, i = 1,7$ Coefficients of the feedback transfer function, FYDAMP, (see the equation below).
11-20	R <sub>2</sub>		
⋮	⋮		
61-70	R <sub>7</sub>		

### Card 10.5-Standard Feedback Coefficients

COLS.	KEYWORD/ VARIABLE	FORMAT	DESCRIPTION
1-10	T <sub>1</sub>	7E10.0	$T_i, i = 1,7$ Coefficients of the feedback transfer function, FYDAMP, (see the equation below).
11-20	T <sub>2</sub>		
⋮	⋮		
61-70	T <sub>7</sub>		

$$\text{Fydamp} = \frac{G(P_1s^2 + U_1s + R_1)(P_2s^2 + U_2s + R_2)(P_3s^2 + U_3s + R_3)(T_1s + 1)}{(P_3s^2 + U_3s + R_3)\dots(P_7s^2 + U_7s + R_7)(T_2s + 1)(T_3s + 1)\dots(T_7s + 1)}$$

Omit cards 10.6 through 10.8 if the standard feedback loop is chosen (IFDBAK  $\leq$  1 on card 4.2).

Card 10.6—Special Feedback Coefficients (see app. B for coefficient definitions)

COLS.	KEYWORD/ VARIABLE	FORMAT	DESCRIPTION
1-10	CS2 <sub>1</sub>	7E10.0	CS2 <sub>i</sub> , i = 1, NDOF where NDOF (Card 4.1) is the number of degrees of freedom.
11-20	CS2 <sub>2</sub>		
⋮	⋮		
	CS2 <sub>NDOF</sub>		Repeat the card with 7 numbers per card until all elements are defined.

Card 10.7—Special Feedback Coefficients (see app. B for coefficient definitions)

COLS.	KEYWORD/ VARIABLE	FORMAT	DESCRIPTION
1-10	CS1 <sub>1</sub>	7E10.0	CS1 <sub>i</sub> , i = 1, NDOF where NDOF (Card 4.1) is the number of degrees of freedom.
11-20	CS1 <sub>2</sub>		
⋮	⋮		
	CS1 <sub>NDOF</sub>		Repeat the card with 7 numbers per card until all elements are defined.

Card 10.8—Special Feedback Coefficients (see app. B for coefficient definitions)

COLS.	KEYWORD/ VARIABLE	FORMAT	DESCRIPTION
1-10	CSO <sub>1</sub>	7E10.0	CSO <sub>i</sub> , i = 1, NDOF where NDOF (Card 4.1) is the number of degrees of freedom.
11-20	CSO <sub>2</sub>		
⋮	⋮		
	CSO <sub>NDOF</sub>		Repeat the card with 7 numbers per card until all elements are defined.

**Card Set 11.0-Frequency Array**

**Card 11.1-Frequencies in Cycles per Second**

Read card 11.1 if IFREQ = -1 on card 4.2.

COLS.	KEYWORD/ VARIABLE	FORMAT	DESCRIPTION
1-10	FREQ <sub>1</sub>	7E10.0	<p>FREQ<sub>i</sub>, i = 1, NFREQ                      where NFREQ (Card 4.1) is the number of frequencies.                      The input frequencies are in cycles per second.</p>
11-20	FREQ <sub>2</sub>		
⋮	⋮		
	FREQ <sub>NFREQ</sub>		
			Repeat the card with 7 numbers per card until all elements are defined.

**Card 11.2-Frequencies in Radians per Second**

Read card 11.2 if IFREQ = 0 on card 4.2.

COLS.	KEYWORD/ VARIABLE	FORMAT	DESCRIPTION
1-10	FREQ <sub>1</sub>	7E10.0	<p>FREQ<sub>i</sub>, i = 1, NFREQ                      where NFREQ (Card 4.1) is the number of frequencies.                      The input frequencies are in radians per second.                      Note: Internally the input frequencies are converted                      from radians per second into cycles per second.</p>
11-20	FREQ <sub>2</sub>		
⋮	⋮		
	FREQ <sub>NFREQ</sub>		
			Repeat the card with 7 numbers per card until all elements are defined.

**Card 11.3—First Frequency and an Increment**

Read card 11.3 if  $IFREQ > 0$  on card 4.2.

COLS.	KEYWORD/ VARIABLE	FORMAT	DESCRIPTION
1-10	$FREQ_1$	E10.0	The first frequency (cps).
11-20	DELTA F	E10.0	The frequency increment in cycles/second.

**Card 11.4—Frequencies at Which the Loads per Degree of Freedom Will Be Printed**

Read card 11.4 if  $LPDOF > 0$  on card 4.3.

Note: If  $IFREQ = 0$  on card 4.2,  $FREQ_{L_i}$  must be in radians per second.

If  $IFREQ = -1$  on card 4.2,  $FREQ_{L_i}$  must be in cycles per second.

COLS.	KEYWORD/ VARIABLE	FORMAT	DESCRIPTION
1-10	$FREQ_{L_1}$	7E10.0	$FREQ_{L_i}$ , $i = 1, LPDOF$ where $LPDOF$ is from Card 4.3. The frequencies at which the loads per degree of freedom will be printed.
11-20	$FREQ_{L_2}$		
⋮	⋮		
	$FREQ_{L_{LPDOF}}$		Repeat the card with 7 numbers per card until all elements are defined.

Note: Given  $FREQ_{L_i}$ ,  $FINDRMS$  will choose the element of the array  $\{FREQ\}$  which is equal to or greater than  $FREQ_{L_i}$ .

$FREQ_{L_i}$  must be  $\leq FREQ_{NFREQ}$ .

## **BLOCK II-Instructions and Matrices Needed To Find the Generalized Coordinates**

BLOCK II, card sets 12.0 through 30.0, always follows BLOCK I. The flow of BLOCK II data cards is displayed in figure 4. BLOCK II is always introduced by card set 12.0.

### **Card Set 12.0-Introduce the Equations of Motion**

COLS.	KEYWORD/ VARIABLE	FORMAT	DESCRIPTION
1-10	<u>\$EQUA</u> tion	A10	This card introduces the cards defining the equations of motion.
11-70			Available for comments.



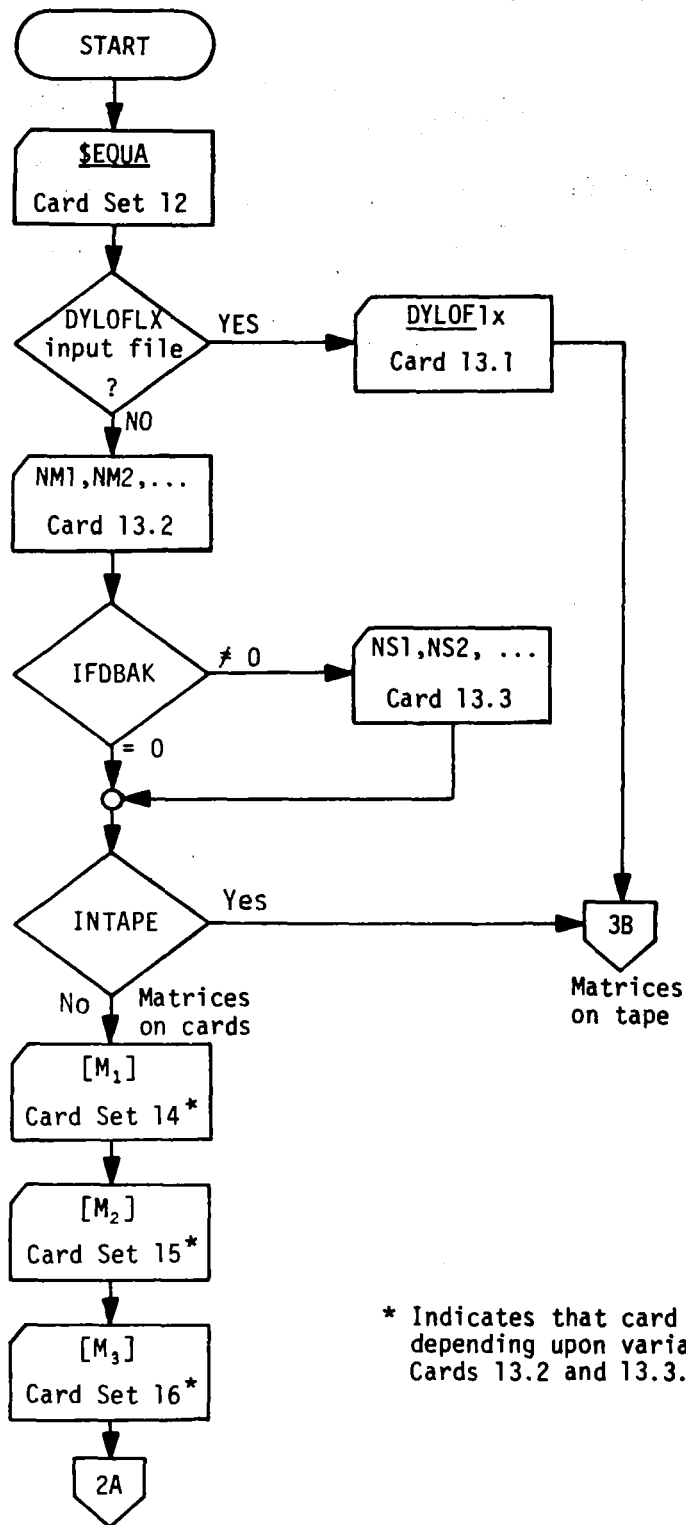

Figure 4.—Flow of FINDRMS Block II Card Input Data

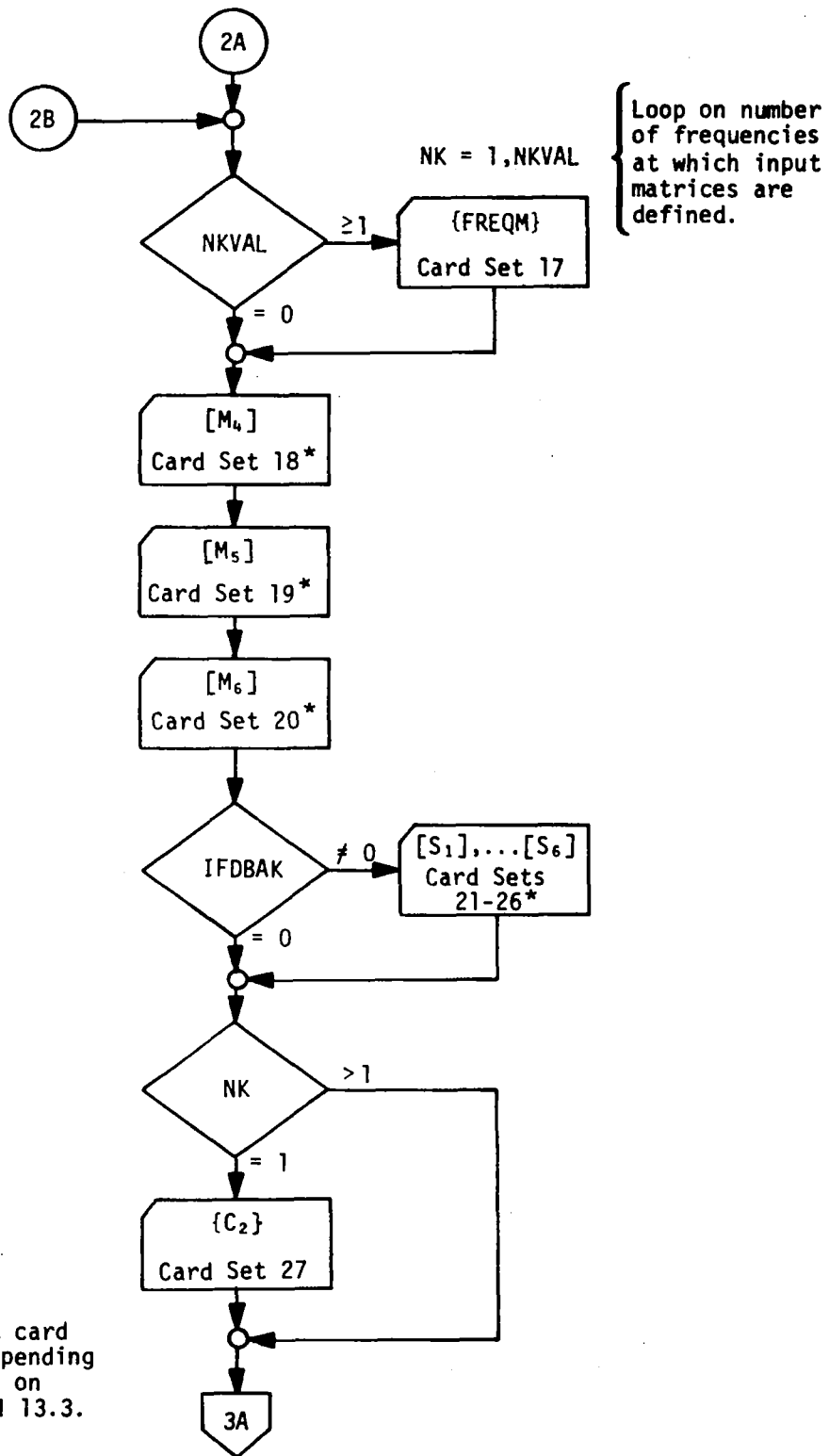

Figure 4.—(Continued)

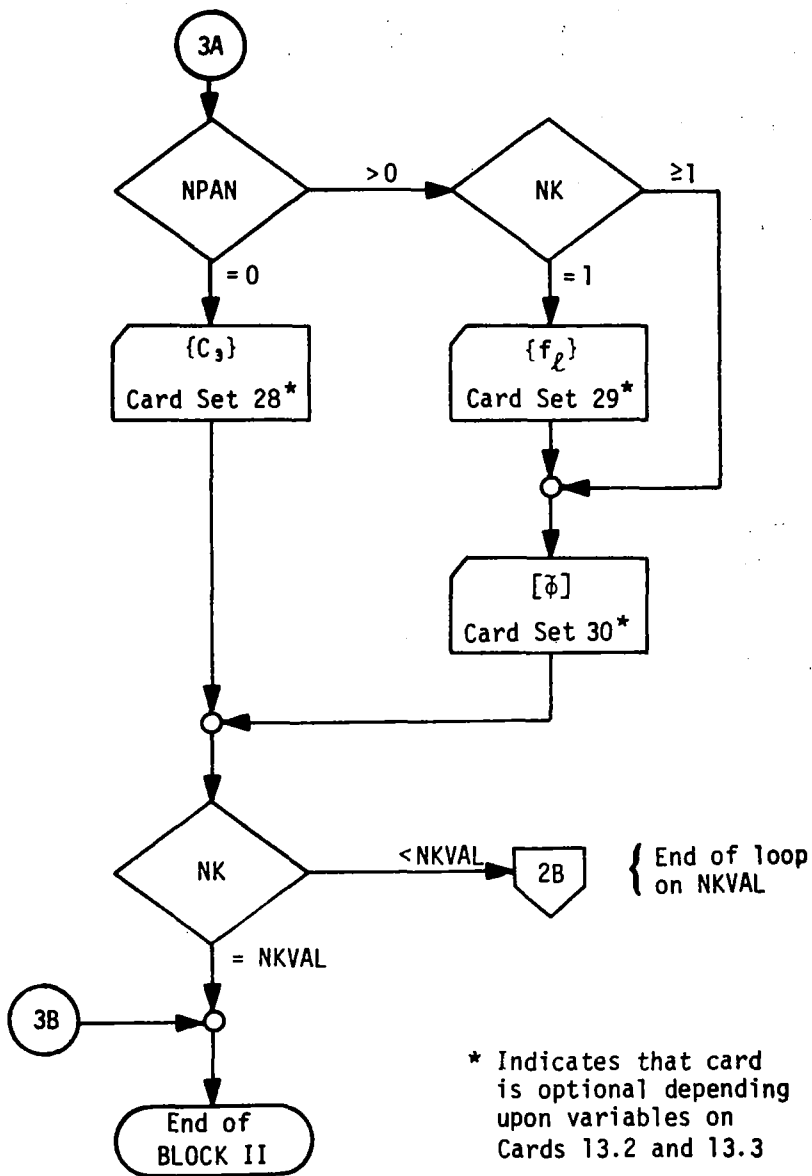

Figure 4.—(Concluded)

### Card Set 13.0--Choose the Non-Null Matrices

Card set 12.0 must be followed by either card 13.1 or 13.2. Card 13.1 indicates that the equations of motion matrices are on magnetic file "INTAPE" which begins with a DYLOFLEX header array (see sec. 6.4). Card 13.2 must be used if the matrices are on cards or if "INTAPE" does not contain the DYLOFLEX header array.

#### Card 13.1--Signal an "INTAPE" With DYLOFLEX Header Array

Omit card 13.1 if the equations of motion are on cards or if "INTAPE" does not contain the DYLOFLEX header array.

COLS.	KEYWORD/ VARIABLE	FORMAT	DESCRIPTION
1-10	DYLOFLX	A10	Keyword indicates that "INTAPE" begins with a DYLOFLEX header array.
11-70			Available for comments.

INTAPE (card 4.4) must be defined in order to use card 13.1. When card 13.1 is used, all other BLOCK II cards (13.1 through 30.0) must be omitted. The DYLOFLEX header array and the equations of motion will be read from magnetic file "INTAPE". The header array at the beginning of "INTAPE" specifies the matrix sizes and indicates which ones are not null and appear on the file (see sec. 6.4)

Card 13.2--Choose Non-Null Equations of Motion Matrices

Omit cards 13.2 and 13.3 if card 13.1 was used.

COLS.	KEYWORD/ VARIABLE	FORMAT	DESCRIPTION
1-5	NM1	I5	<p>NM1, i = 1,6</p> <p>If NMi = 0 the corresponding equation of motion matrix [M<sub>i</sub>] will not be read. It is assumed to be null.</p> <p>If NMi &gt; 0 the matrix [M<sub>i</sub>] will be read.</p>
6-10	NM2	I5	
11-15	NM3	I5	
16-20	NM4	I5	
21-25	NM5	I5	
26-30	NM6	I5	
31-35	NC2	I5	<p>If NC2 = 0 the corresponding equation of motion forcing function coefficient matrix {C<sub>2</sub>} or [C<sub>2</sub>] will not be read. It is assumed to be null.</p> <p>If NC2 &gt; 0 the matrix {C<sub>2</sub>} or [C<sub>2</sub>] will be read.</p>
36-40	NC3	I5	<p>If NC3 = 0 the corresponding equation of motion convoluted forcing function coefficient matrix {C<sub>3</sub>} or [C<sub>3</sub>] will not be read. It is assumed to be null.</p> <p>If NC3 &gt; 0 the matrix {C<sub>3</sub>} or [C<sub>3</sub>] will be read.</p> <p>Note: If the number of panels (NPAN of Card 4.1) is &gt; 0, then NC3 is set to zero.</p>
41-45	NFLL	I5	<p>If NFLL = 0 the corresponding matrix of the streamline distance in feet from the point first encountering gusts to the points encountering gusts later will not be read. It is assumed to be null.</p> <p>If NFLL = 1 the matrix {f<sub>2</sub>} will be read.</p> <p>Note: If the number of panels (NPAN of Card 4.1) is = 0 then NFLL should be zero.</p>

46-50	NPHIT	I5	<p>If NPHIT = 0 the corresponding matrix of the gust forces acting on each gradual penetration lifting panel will not be read.</p> <p>If NPHIT = 1 the matrix <math>[\phi]</math> will be read.</p> <p>Note: If the number of panels (NPAN of Card 4.1) is = 0, then NPHIT should be zero.</p>
-------	-------	----	--

### Card 13.3--Choose Non-Null Feedback Matrices

Omit card 13.3 if card 13.1 was input or if IFDBAK of card 4.2 = 0.

COLS.	KEYWORD/ VARIABLE	FORMAT	DESCRIPTION
1-5	NS1	I5	<p>NS<sub>i</sub>, i = 1,6</p> <p>= 0 the corresponding coefficient of feedback for the equations of motion matrix, <math>[S_i]</math>, will not be read. It will be assumed null.</p> <p>&gt; 0 the corresponding matrix, <math>[S_i]</math>, will be read.</p>
6-10	NS2	I5	
11-15	NS3	I5	
16-20	NS4	I5	
21-25	NS5	I5	
26-30	NS6	I5	

Omit card sets 14.0 through 30.0 if INTAPE of card 4.4 is defined. Instead, the matrices will be read from the magnetic file "INTAPE".

### Card Set 14.0 $[M_1]$ --Generalized Stiffness Matrix

Omit card set 14.0 if NM1 = 0 on card 13.2.  $[M_1]$  is of size NDOF x NDOF.

### Card Set 15.0 $[M_2]$ --Viscous Structural Damping Matrix

Omit card set 15.0 if NM2 = 0 on card 13.2.  $[M_2]$  is of size NDOF x NDOF.

### Card Set 16.0 $[M_3]$ --Generalized Mass Matrix

Omit card set 16.0 if NM3 = 0 on card 13.2.  $[M_3]$  is of size NDOF x NDOF.

### Card Set 17.0 {FREQM}--Frequencies at Which the Aerodynamic Equations of Motion Are Defined

Omit card set 17.0 if NKVAL = 0 on card 4.1. {FREQM} is of size 1 x NKVAL.

Repeat card sets 18.0 through 30.0 NKVAL TIMES:  $NK = 1$ , NKVAL.

**Card Set 18.0  $[M_4]$ -Convolutd Generalized Coordinate Displacement Matrix**

Omit card set 18.0 if  $NM4 = 0$  on card 13.2.  $[M_4]$  is of size NDOF x NDOF.

**Card Set 19.0  $[M_5]$ -Convolutd Generalized Coordinate Rate Matrix**

Omit card set 19.0 if  $NM5 = 0$  on card 13.2.  $[M_5]$  is of size NDOF x NDOF.

**Card Set 20.0  $[M_6]$ -Convolutd Generalized Coordinate Acceleration Matrix**

Omit card set 20.0 if  $NM6 = 0$  on card 13.2.  $[M_6]$  is of size NDOF x NDOF.

Omit card sets 21.0 through 26.0 if  $IFDBAK = 0$  on card 4.2.

**Card Set 21.0  $[S_1]$ -Feedback Coefficient Matrix for Generalized Coordinate Displacement**

Omit card set 21.0 if  $NS1 = 0$  on card 13.3.  $[S_1]$  is of size NDOF x NDOF.

**Card Set 22.0  $[S_2]$ -Feedback Coefficient Matrix for Generalized Coordinate Rate**

Omit card set 22.0 if  $NS2 = 0$  on card 13.3.  $[S_2]$  is of size NDOF x NDOF.

**Card Set 23.0  $[S_3]$ -Feedback Coefficient Matrix for Generalized Coordinate Acceleration**

Omit card set 23.0 if  $NS3 = 0$  on card 13.3.  $[S_3]$  is of size NDOF x NDOF.

**Card Set 24.0  $[S_4]$ -Feedback Coefficient Matrix for Convolutd Generalized Coordinate Displacement**

Omit card set 24.0 if  $NS4 = 0$  on card 13.3.  $[S_4]$  is of size NDOF x NDOF.

**Card Set 25.0  $[S_5]$ -Feedback Coefficient Matrix for Convolutd Generalized Coordinate Rate**

Omit card set 25.0 if  $NS5 = 0$  on card 13.3.  $[S_5]$  is of size NDOF x NDOF.

**Card Set 26.0  $[S_6]$ -Feedback Coefficient Matrix for Convolutd Generalized Coordinate Acceleration**

Omit card set 26.0 if  $NS6 = 0$  on card 13.3.  $[S_6]$  is of size NDOF x NDOF.

**Card Set 27.0  $\{C_2\}$ -Forcing Function Coefficient Matrix**

Omit card set 27.0 if  $NC2 = 0$  on card 13.2.  $\{C_2\}$  is of size NDOF x 1. Input as a row.

### **Card Set 28.0 $\{C_3\}$ -Convolved Forcing Function Coefficient Matrix**

Omit card set 28.0 if  $NC3 = 0$  on card 13.2 or if  $NPAN > 0$  on card 4.1.

If there is a single forcing function ( $NFORC = 0$  on card 4.1),  $\{C_3\}$  is of size  $NDOF \times 1$  and is input as a row.

However, if the equations of motion are frequency dependent ( $NKVAL > 0$  on card 4.1),  $\{C_3\}$  is complex and must be input as a row of size  $2*NDOF$  with alternating real and imaginary parts.

If there are multiple forcing functions ( $NFORC > 0$  on card 4.1),  $[C_3]$  is of size  $NDOF \times NFORC$ .

However, if in addition the equations of motion are frequency dependent ( $NKVAL > 0$  on card 4.1),  $[C_3]$  is complex and must be input by rows with  $2*NFORC$  numbers per row, alternating real and imaginary parts.

### **Card Set 29.0 $\{f_l\}$ -Distances Between First Panel and Other Gradual Penetration Panels**

Omit card set 29.0 if  $NPAN = 0$  on card 4.1.

Also, card set 29.0 is input only for the first frequency.  $\{f_l\}$  is of size  $NPAN \times 1$ . Input as a row.

### **Card Set 30.0 $[\tilde{\phi}]$ -Gust Forces Acting on Each Gradual Penetration Lifting Panel**

Omit card set 30.0 if  $NPAN = 0$  on card 4.1.  $[\tilde{\phi}]$  is of size  $NDOF \times NPAN$ .

$[\tilde{\phi}]$  contains real numbers if  $NKVAL = 0$  on card 4.1.

$[\tilde{\phi}]$  contains complex numbers if  $NKVAL > 0$  indicating that the matrices are frequency dependent. When  $[\tilde{\phi}]$  is complex, it is input with alternating real and imaginary parts;  $2*NPAN$  numbers to a row.



### BLOCK III-Instructions and Matrices Needed for the Loads Solution

BLOCK III, card sets 31.0 through 48.0, follows BLOCK II. BLOCK III may be repeated 10 times, once for each load set. The flow of BLOCK III data cards is displayed in figure 5. BLOCK III is always introduced by card set 31.0. The end-of-load sets and the end of FINDRMS execution are indicated by card set 48.0, \$END.

#### Card Set 31.0-Load Instructions

COLS.	KEYWORD/ VARIABLE	FORMAT	DESCRIPTION
1-10	\$LOAD	A10	The keyword indicating that a new load set will be processed.
11-15	NLD	I5	The number of load equations in this load set. (NLD ≤ 100)
16-20	ICORR	I5	The number of loads to be correlated with other loads. If NFORC of Card 4.1 > 1, loads correlation can not be used. (ICORR ≤ NLD)
21-30	$\bar{C}$ (GPSCLB)	E10.0	The scaling factor which is only used for gradual penetration. See eqn 22 of Section 5.0. ( $\bar{C}$ > 0)
31-40	LDTAPE	A10	The magnetic file name that will contain the load equations input matrices.  The tape name is defined as a one to seven character name, beginning with an alphabetic character and being left justified.  If LDTAPE is left blank it will default to being the same as INTAPE on Card 4.4.  If the load equations are to be input by cards, LDTAPE is left blank.  Note: Load equation matrices can only be read in by cards if the equations of motion matrices are read in by Cards, that is, if INTAPE on Card 4.4 is left blank

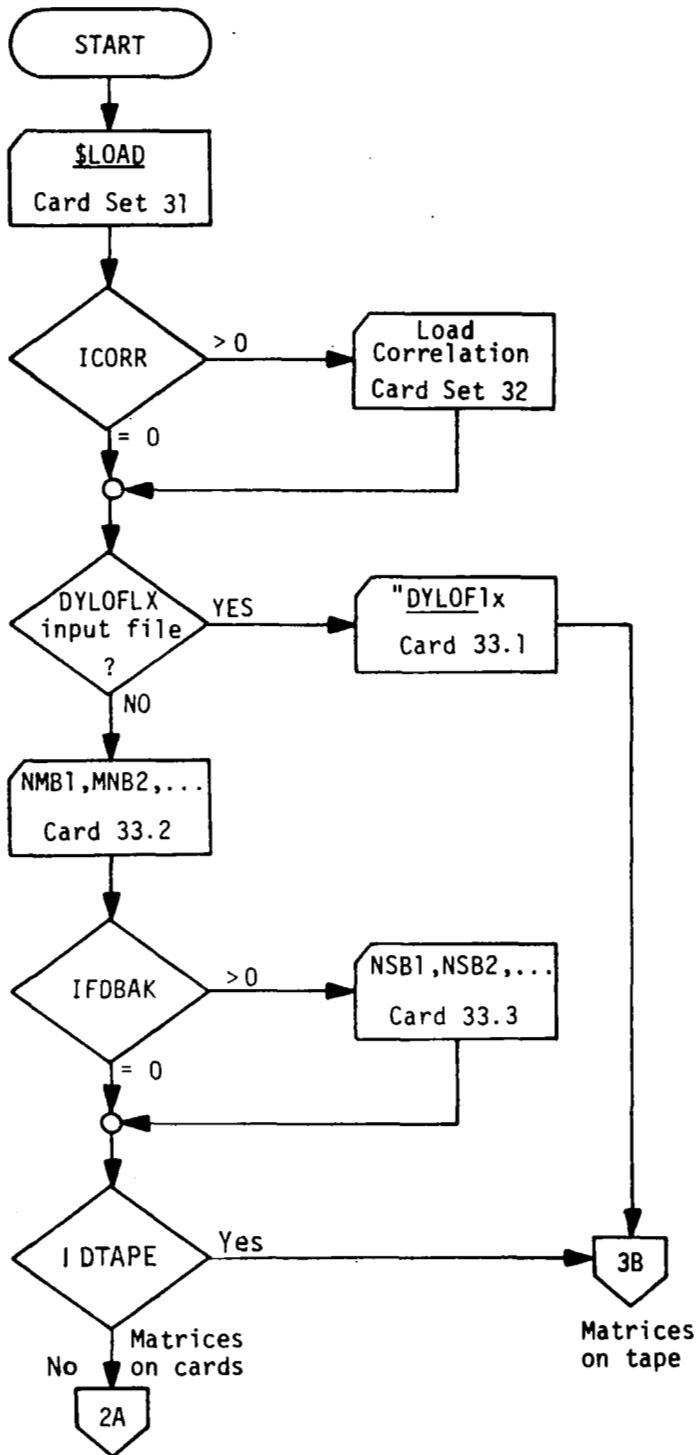

Figure 5.—Flow of FINDRMS Block III Card Input Data

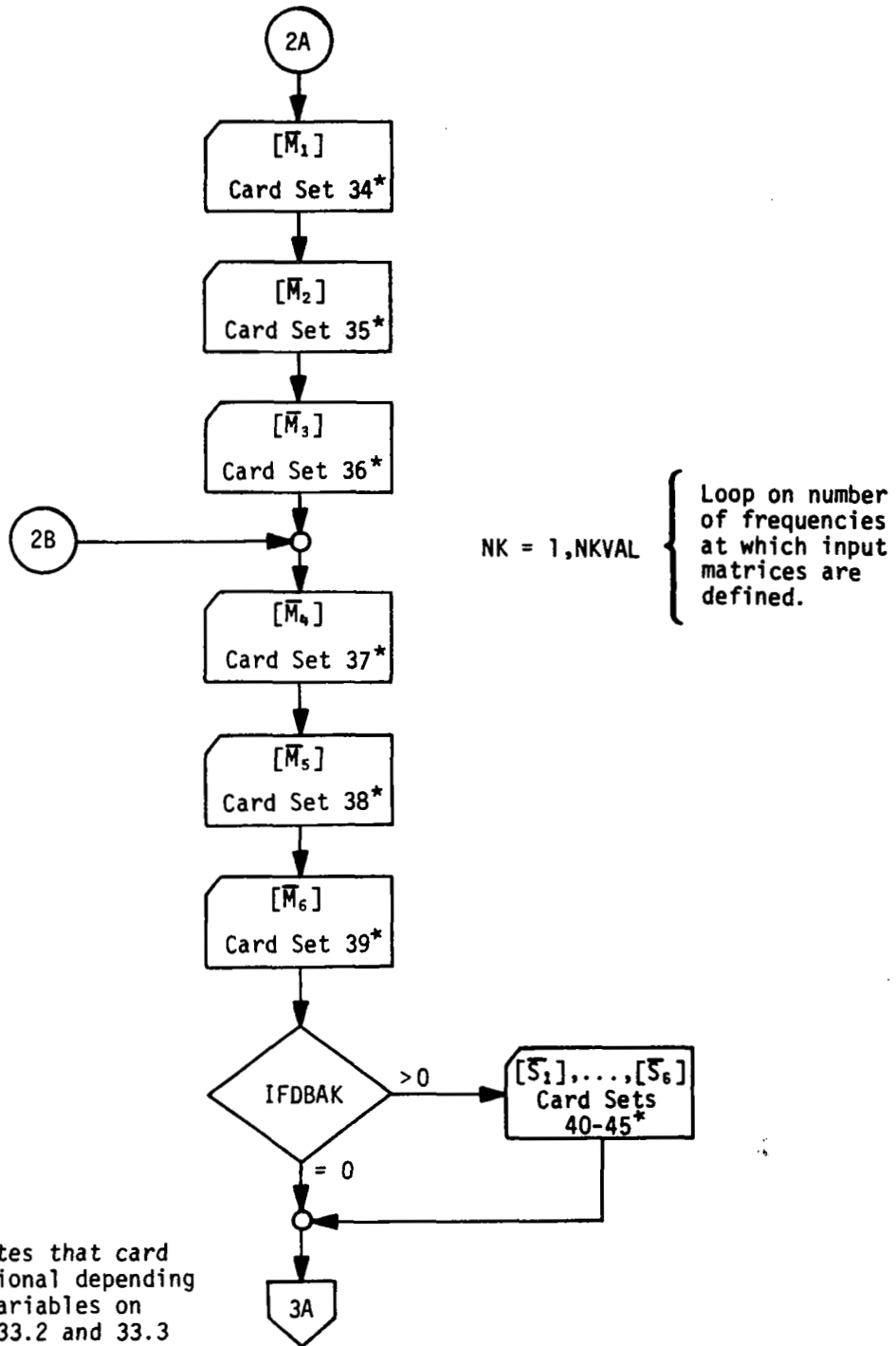

Figure 5.—(Continued)

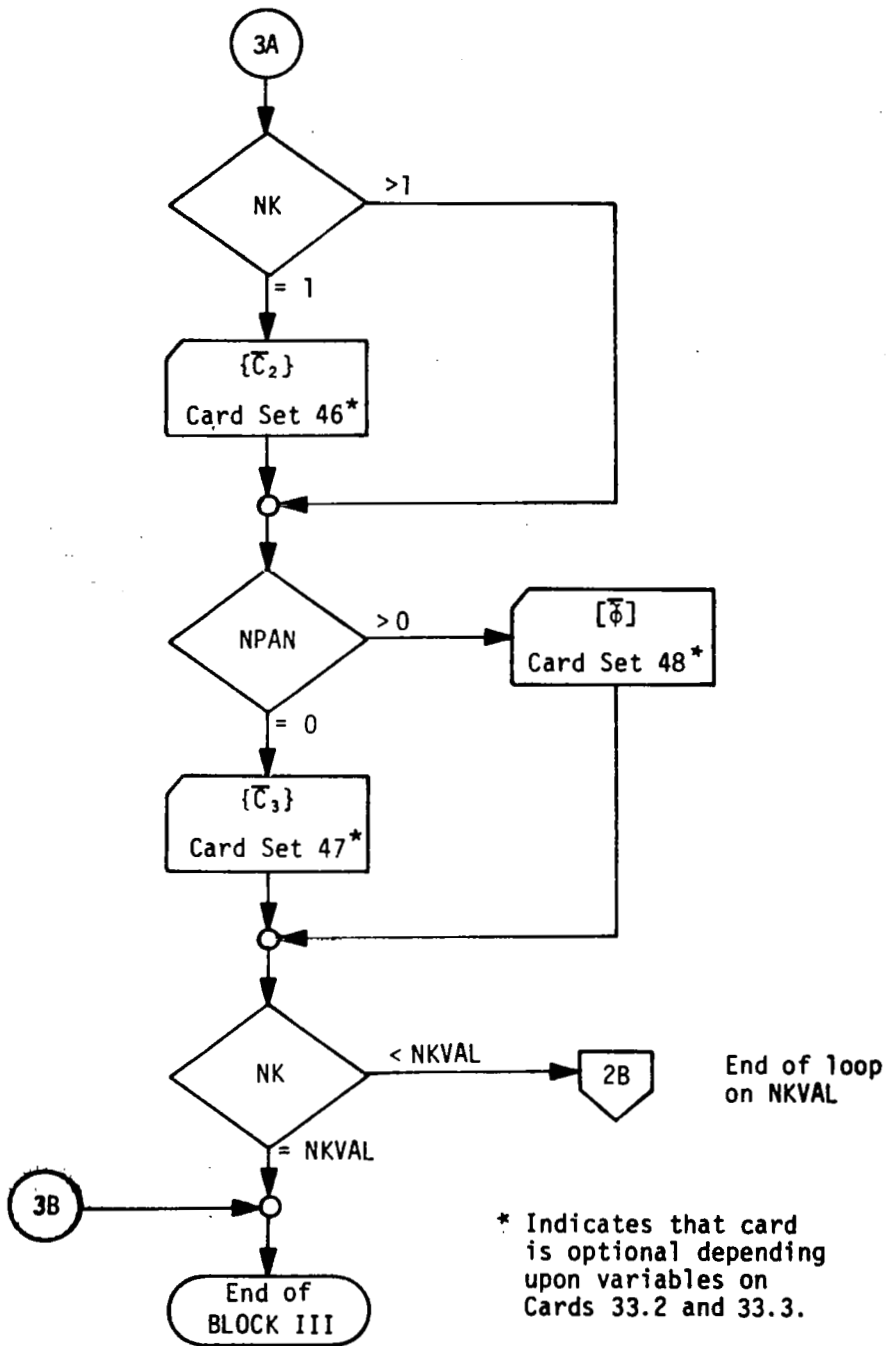

Figure 5.—(Concluded)

### Card Set 32.0—Load Correlation Specifications

Omit card set 32.0 if ICORR of card set 31.0 = 0, or if NFORC of card 4.1 > 1.  
Repeat card set 32.0 ICORR times.

COLS.	KEYWORD/ VARIABLE	FORMAT	DESCRIPTION
1-5	$LOAD_i$	I5	The load number that is to be correlated with up to 10 other loads.
6-10	$LOADC_{(i,1)}$	I5	The loads to be correlated with $LOAD_i$ . $(LOAD_i \leq NLD)$
11-15	$LOADC_{(i,2)}$		
⋮	⋮		
51-55	$LOADC_{(i,10)}$		

The load number  $LOAD_i$  will be correlated with the loads numbered  $(LOADC_{(i,j)}, j = 1, 10)$ .

### Card Set 33.0-Choose the Non-Null Matrices

Card 33.1 indicates that the load equation matrices are on magnetic file "LDTAPE" which begins with a DYLOFLEX header array (see sec. 6.4.1). Card 33.2 must be used if the matrices are on cards or if "LDTAPE" does not contain the DYLOFLEX header array.

#### Card 33.1-Signal "LDTAPE" With DYLOFLEX Header Array

Omit card 33.1 if the load equations are on cards or if "LDTAPE" does not contain the DYLOFLEX header array.

COLS.	KEYWORD/ VARIABLE	FORMAT	DESCRIPTION
1-10	DYLOFLX	A10	Keyword indicates that "LDTAPE" begins with a DYLOFLEX header array.
11-70			Available for comments.

"LDTAPE" (card set 31.0) or "INTAPE" (card 4.4) must be defined in order to use card 33.1. When card 33.1 is used, all other BLOCK III cards (33.2 through 48.0) must be omitted. The DYLOFLEX header array and the load equations will be read from magnetic file "LDTAPE". The DYLOFLEX header array at the beginning of "LDTAPE" specifies the sizes of the matrices and indicates which ones are not null and appear on the file (see sec. 6.4.1).

### Card 33.2—Choose Non-Null Load Equation Matrices

Omit card 33.2 if card 33.1 was input.

COLS.	KEYWORD/ VARIABLE	FORMAT	DESCRIPTION
1-5	NMB1	I5	<p>NMB<sub>i</sub>, i = 1,6</p> <p>If NMB<sub>i</sub> = 0 the corresponding load equations <math>[\bar{M}_i]</math> will not be read. It is assumed to be null.</p> <p>If NMB<sub>i</sub> = 1 the matrix <math>[\bar{M}_i]</math> will be read.</p>
6-10	NMB2	I5	
11-15	NMB3	I5	
16-20	NMB4	I5	
21-25	NMB5	I5	
26-30	NMB6	I5	
31-35	NC2B	I5	<p>If NC2B = 0 the load equation forcing function coefficient matrix <math>\{\bar{C}_2\}</math> or <math>[\bar{C}_2]</math> will not be read. It is assumed to be null.</p> <p>If NC2B = 1 the matrix <math>\{\bar{C}_2\}</math> or <math>[\bar{C}_2]</math> will be read.</p>
36-40	NC3B	I5	<p>If NC3B = 0 the load equation convoluted forcing function coefficient matrix will not be read. It is assumed to be null.</p> <p>If NC3B = 1 the matrix <math>\{\bar{C}_3\}</math> or <math>[\bar{C}_3]</math> will be read.</p> <p>Note: If the number of panels (NPAN of Card 4.1) is &gt; 0, then NC3B is set to zero.</p>
41-45	NPHITB	I5	<p>If NPHITB = 0 the lifting panel contributions to the gust loads of designated gradual penetration load stations matrix <math>[\bar{\phi}]</math> will not be read. It is assumed to be null.</p> <p>If NPHITB = 1 the matrix <math>[\bar{\phi}]</math> will be read.</p> <p>Note: If the number of panels (NPAN of Card 4.1) = 0, then NPHITB is set to zero.</p>

**Card 33.3-Choose Non-Null Feedback Matrices**

Omit card 33.3 if card 33.1 was input or if IFDBAK = 0 on card 4.2.

COLS.	KEYWORD/ VARIABLE	FORMAT	DESCRIPTION
1-5	NSB1	I5	NSB <sub>i</sub> , i = 1,6
6-10	NSB2	I5	If NSB <sub>i</sub> = 0 the load equation feedback coefficient matrix $[\bar{S}_i]$ will not be read. It is assumed to be null.
11-15	NSB3	I5	
16-20	NSB4	I5	If NSB <sub>i</sub> = 1 the matrix $[\bar{S}_i]$ will be read.
21-25	NSB5	I5	
26-30	NSB6	I5	

Omit card sets 34.0 through 48.0 if the matrices are to be read from magnetic file "LDTAPE" (card set 31.0).

Note: Format of matrices input on cards is detailed previously in section 6.3.1.

**Card Set 34.0  $[\bar{M}_1]$ -Load Equation Matrix Corresponding to Generalized Coordinate Displacement**

Omit card set 34.0 if NMB1 = 0 on card 33.2.  $[\bar{M}_1]$  is of size NLD x NDOF.

**Card Set 35.0  $[\bar{M}_2]$ -Load Equation Matrix Corresponding to Generalized Coordinate Rate**

Omit card set 35.0 if NMB2 = 0 on card 33.2.  $[\bar{M}_2]$  is of size NLD x NDOF.

**Card Set 36.0  $[\bar{M}_3]$ -Load Equation Matrix Corresponding to Generalized Coordinate Acceleration**

Omit card set 36.0 if NMB3 = 0 on card 33.2.  $[\bar{M}_3]$  is of size NLD x NDOF.

Repeat card set 37.0 through 48.0 NKVAL times; NK = 1, NKVAL.

**Card Set 37.0  $[\bar{M}_4]$ -Load Equation Matrix Corresponding to Convolved Generalized Coordinate Displacement**

Omit card set 37.0 if NMB4 = 0 card 33.2.  $[\bar{M}_4]$  is of size NLD x NDOF.

**Card Set 38.0  $[\bar{M}_5]$ -Load Equation Matrix Corresponding to Convolved Generalized Coordinate Rate**

Omit card set 38.0 if NMB5 = 0 on card 33.2.  $[\bar{M}_5]$  is of size NLD x NDOF.



**Card Set 39.0  $[\bar{M}_6]$ -Load Equation Matrix Corresponding to Convoluted Generalized Coordinate Acceleration**

Omit card set 39.0 if NMB6 = 0 on card 33.2.  $[\bar{M}_6]$  is of size NLD x NDOF.

Omit card sets 40.0 through 45.0 if IFDBAK = 0 on card 4.2.

**Card Set 40.0  $[\bar{S}_1]$ -Load Equation Feedback Coefficient Matrix for Generalized Coordinate Displacement**

Omit card set 40.0 if NS1 = 0 on card 33.3.  $[\bar{S}_1]$  is of size NLD x NDOF.

**Card Set 41.0  $[\bar{S}_2]$ -Load Equation Feedback Coefficient Matrix for General Coordinate Rate**

Omit card set 41.0 if NS2 = 0 on card 33.3.  $[\bar{S}_2]$  is of size NLD x NDOF.

**Card Set 42.0  $[\bar{S}_3]$ -Load Equation Feedback Coefficient Matrix for General Coordinate Acceleration**

Omit card set 42.0 if NS3 = 0 on card 33.3.  $[\bar{S}_3]$  is of size NLD x NDOF.

**Card Set 43.0  $[\bar{S}_4]$ -Load Equation Feedback Coefficient Matrix for Convoluted Generalized Coordinate Displacement**

Omit card set 43.0 if NS4 = 0 on card 33.3.  $[\bar{S}_4]$  is of size NLD x NDOF.

**Card Set 44.0  $[\bar{S}_5]$ -Load Equation Feedback Coefficient Matrix for Convoluted Generalized Coordinate Rate**

Omit card set 44.0 if NS5 = 0 on card 33.3.  $[\bar{S}_5]$  is of size NLD x NDOF.

**Card Set 45.0  $[\bar{S}_6]$ -Load Equation Feedback Coefficient Matrix for Convoluted Generalized Coordinate Acceleration**

Omit card set 45.0 if NS6 = 0 on card 33.3.  $[\bar{S}_6]$  is of size NLD x NDOF.

**Card Set 46.0  $\{\bar{C}_2\}$ -Load Equation Coefficient Matrix for the Forcing Function**

Omit card set 46.0 if NC2 = 0 on card 33.2.  $\{\bar{C}_2\}$  is of size NLD x 1. Input as a row.

**Card Set 47.0  $\{\bar{C}_3\}$ -Load Equation Coefficient Matrix for the Convoluted Forcing Function**

Omit card set 47.0 if NC3 = 0 on card 33.2 or if NPAN > 0 on card 4.1.

If there is a single forcing function (NFORC = 0 on card 4.1),  $\{\bar{C}_3\}$  is of size NLD x 1 and is input as a row.

However, if the equations of motion are frequency dependent ( $NKVAL > 0$  on card 4.1),  $\{\bar{C}_3\}$  is complex and must be input as a row of size  $2 \times NLD$  with alternating real and imaginary parts.

If there are multiple forcing functions ( $NFORC > 0$  on card 4.1),  $[\bar{C}_3]$  is of size  $NLD \times NFORC$ .

However, if in addition the equations of motion are frequency dependent ( $NKVAL > 0$  on card 4.1),  $[\bar{C}_3]$  is complex and must be input by rows with  $2 \times NFORC$  numbers per row, alternating real and imaginary parts.

**Card Set 48.0  $[\bar{\phi}]$ -Gradual Penetration Load Equation Coefficient Matrix for the Convolved Forcing Function**

Omit card set 48.0 if  $NPAN = 0$  on card 4.1.  $[\bar{\phi}]$  is of size  $NLD \times NPAN$ .

$[\bar{\phi}]$  contains real numbers if  $NKVAL = 0$  on card 4.1 and complex numbers if  $NKVAL > 0$ , indicating that the matrices are frequency dependent. When  $[\bar{\phi}]$  is complex, it is input with alternating real and imaginary parts,  $2 \times NPAN$  numbers to a row.

**Card Set 49.0-Termination of FINDRMS**

COLS.	KEYWORD/ VARIABLE	FORMAT	DESCRIPTION
1-10	<u>SEND</u>	A10	This card will cause the termination of the execution of FINDRMS. After this card is read, control of the L221 (TEV156) program will be returned to the main overlay, TEV156.

### 6.3.4 PROGRAM SORTQLS

All of the cards read by the second primary overlay SORTQLS are identified by a code word beginning in column one and have fixed field input of the required numbers.

The recognized code words and possible parameters are shown in the following listing. The keyword parameters are underlined, and only the capital letter variables are relevant.

<u>Card set</u>	<u>Keyword</u>	<u>Variables</u>									
51	<u>TITLE</u>	Miscellaneous titling information									
52	<u>TAPE</u>	Magnetic file "NEWTPE" used for output									
53	<u>REStArt</u>	Restart with MDOF, MFREQ, MSTATE, MPLTPE, MRTAPE, NGROUP, and NSETS									
54	<u>LOAD</u>	Load set number JSET									
55	<u>STATIc</u>	Static-elastic solution from load set JSET									
56	<u>PAIR</u>	Pair the standard and the static-elastic solutions									
57	<u>SEPARate</u>	Separate standard and the static-elastic solutions									
58	<u>SCALE</u>	Scale the axes with SCALX and SCALY									
		Sort and retain the requested item:									
		<table border="0"> <tr> <td rowspan="4" style="font-size: 4em; vertical-align: middle;">}</td> <td><u>Q</u></td> <td>Generalized coordinates</td> </tr> <tr> <td><u>L</u></td> <td>Loads</td> </tr> <tr> <td><u>S</u></td> <td>Spectra</td> </tr> <tr> <td><u>R</u></td> <td>RMS values</td> </tr> </table>	}	<u>Q</u>	Generalized coordinates	<u>L</u>	Loads	<u>S</u>	Spectra	<u>R</u>	RMS values
}	<u>Q</u>	Generalized coordinates									
	<u>L</u>	Loads									
	<u>S</u>	Spectra									
	<u>R</u>	RMS values									
59	<u>SORT</u>										
60	<u>SORT</u>	<u>A</u> All items sorted and retained									
61	<u>\$END</u>	Terminates SORTQLS execution									

General information on the processing of the second primary overlay SORTQLS is presented in the following paragraphs.

Card sets 52.0 through 58.0 (TAPE, RESTA, LOAD, STATI, PAIR, SEPAR, and SCALE) simply set options or give directions to SORTQLS—*no immediate action is taken.*

The SORT card (card sets 59.0 and 60.0) causes SORTQLS to read the input magnetic file, sort the items specified, and write the magnetic file "NEWTPE". Therefore, all desired options must be declared *before* the SORT card is input.

SORTQLS will continue to process data cards and sort the specified items until it reads the \$END card (card set 61.0) which will terminate the SORTQLS processing.

The option cards LOAD, STATI, PAIR, SEPAR, and SCALE (card sets 54.0 through 58.0) may be inserted any number of times. The last specified card set will remain in effect.

The flow of SORTQLS card input is displayed in figure 6.

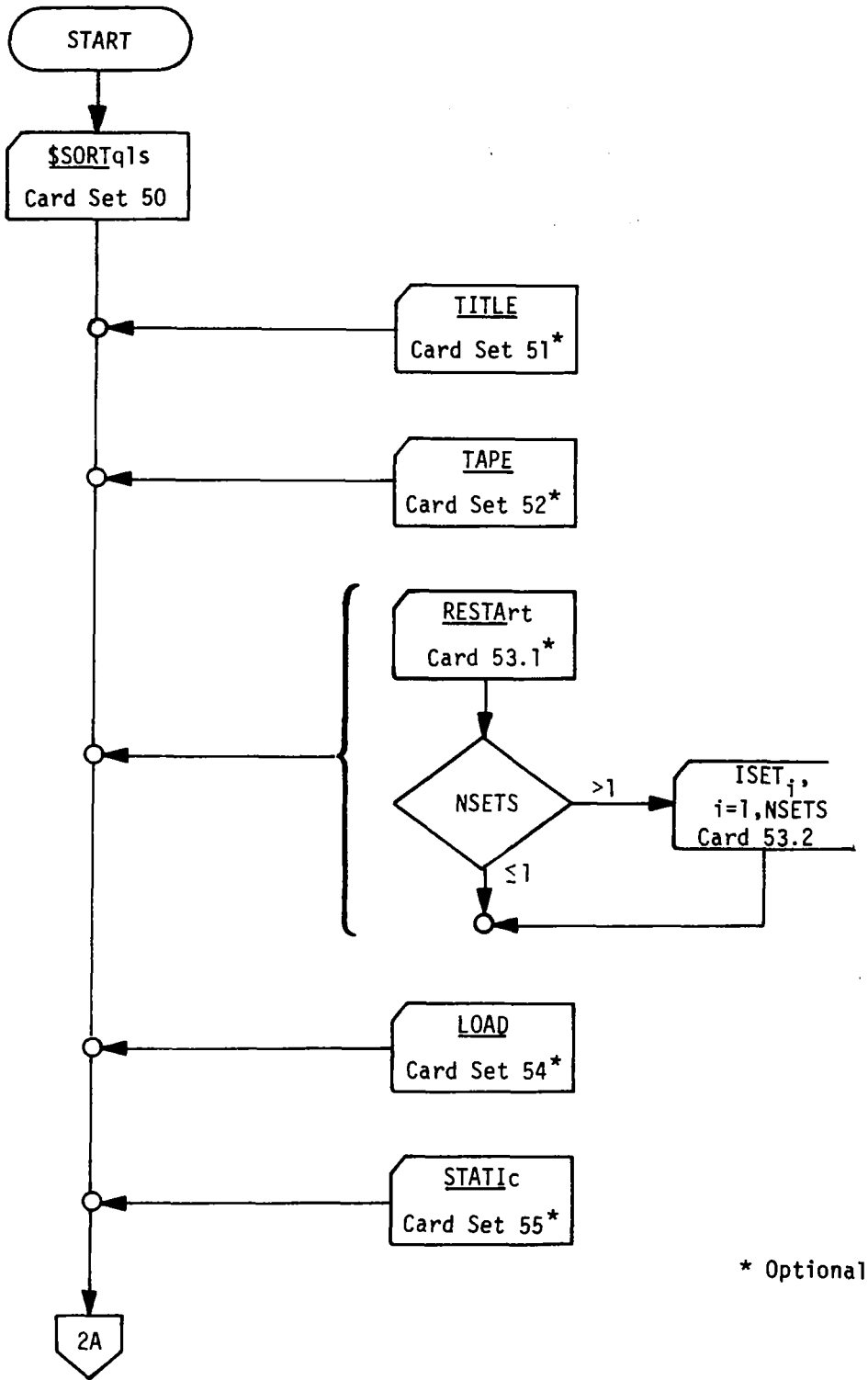
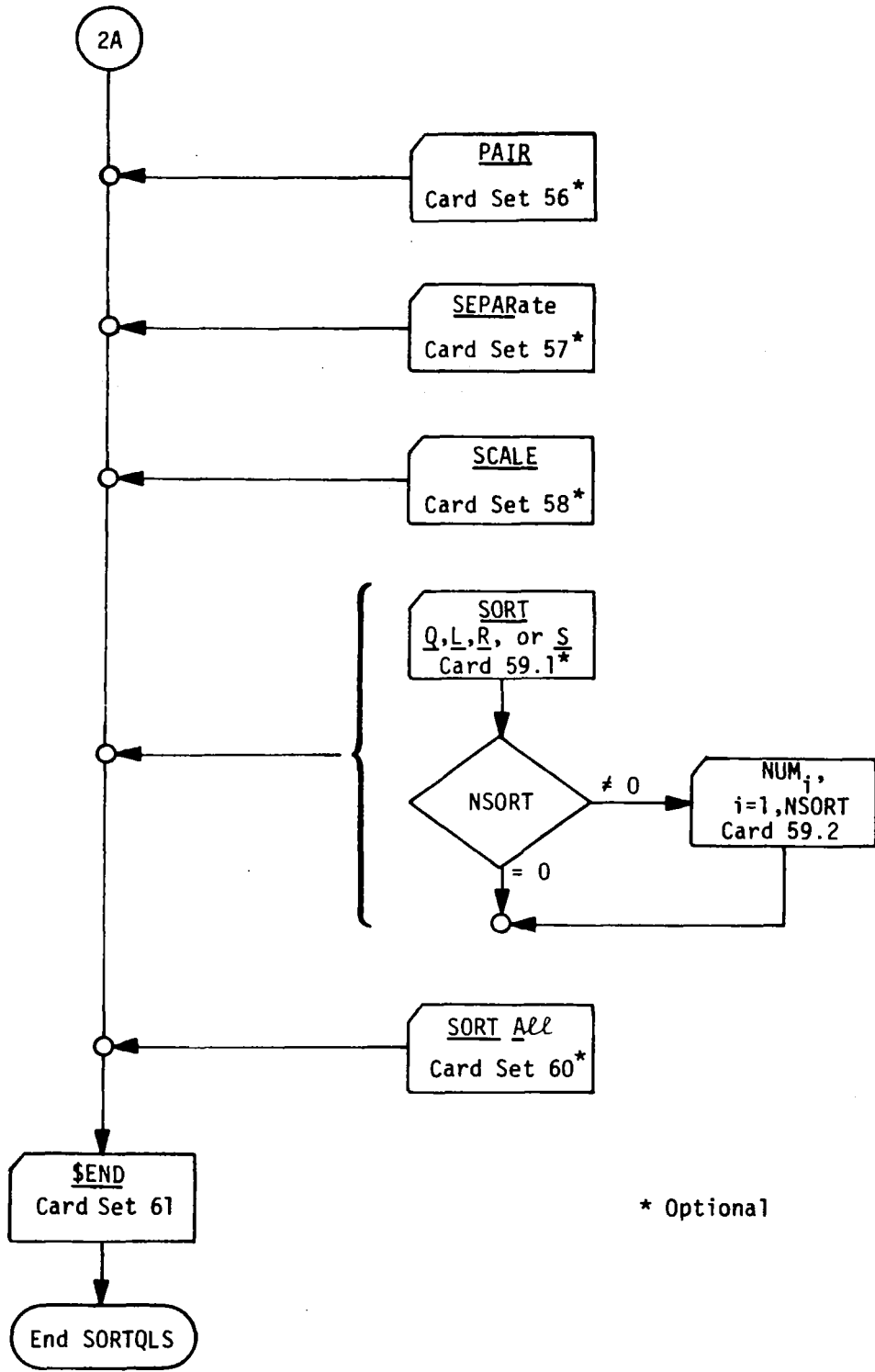

Figure 6.—Flow of SORTQLS Card Input Data



\* Optional

Figure 6.—(Concluded)

### Card Set 50.0-SORTQLS Call Card

COLS.	KEYWORD/ VARIABLE	FORMAT	DESCRIPTION
1-10	<u>\$SORTqls</u>	A10	This card initializes the call to the second primary overlay, SORTQLS. It introduces SORTQLS data cards. SORTQLS will perform the required sorting, and return control to the main overlay after Card Set 61 has been read.
11-70			Available for comments.

### Card Set 51.0-Title Card

COLS.	KEYWORD/ VARIABLE	FORMAT	DESCRIPTION
1-10	<u>TITLE</u>	A10	A keyword indicating a title card.
11-70	description	6A10	Any miscellaneous title description. The card will be read, printed on the output file, and ignored.

### Card Set 52.0-Tape Card

COLS.	KEYWORD/ VARIABLE	FORMAT	DESCRIPTION
1-10	<u>TAPE</u>	A10	A keyword indicating a tape definition card.
11-20	NEWTPE	A10	The sorted plot vectors will be written in READTP/WRTETP format on the magnetic file "NEWTPE".

Card set 52.0 should be input only once at the beginning of SORTQLS's execution. Magnetic file "NEWTPE" will contain the sorted plot vectors. If this option is not used, then the default of "NEWTPE" is PLTPSD.

### Card Set 53.0--Restart L221 (TEV156)

Card set 53.0 is intended to restart L221 (TEV156) to sort a FINDRMS tape from a previous run. It is needed to specify information to SORTQLS which is normally passed through labeled common from FINDRMS.

#### Card 53.1--Restart Card Variables

COLS.	KEYWORD/ VARIABLE	FORMAT	DESCRIPTION
1-10	REStArt	A10	A keyword introducing a card of problem size variables.
11-15	MDOF	I5	The number of degrees of freedom. (MDOF $\leq$ 100)
16-20	MFREQ	I5	The number of frequencies. (MFREQ $>$ 1)
21-25	MSTATE	I5	The static-elastic solution. = 0 <u>no</u> static-elastic solution was previously found. = 1 a static-elastic solution was previously found.
26-35	MPLTPE	A10	The magnetic file "IPLTPE" previously defined by FINDRMS. If MPLTPE is <u>not</u> to be defined, then leave the variable blank, otherwise, the magnetic file name must be a left-justified, 1 to 7 character file, name with the first character being alphabetic.
36-45	MRTAPE	A10	The magnetic file which contains the load transfer functions. If MRTAPE is <u>not</u> to be defined, then leave the variable blank, otherwise, the magnetic file name must be a left-justified, 1 to 7 character file name, with the first character being alphabetic.
46-50	NGROUP	I5	The number of items contained on the magnetic file defined by MPLTPE for each frequency. (NGROUP $\geq$ 3)
51-55	NSETS	I5	The number of sets of load equations. (NSETS $\leq$ 10)
56-60	ISSET	I5	If NSETS = 1 the number of loads in load set 1. If NSETS is greater than 1 this field is to be left blank.



Read card 53.2 to specify the number of loads in each load set if NSETS of card 53.1 > 1.

**Card 53.2-Number of Sets of Load Equations**

COLS.	KEYWORD/ VARIABLE	FORMAT	DESCRIPTION
1-5	ISET <sub>1</sub>	10I5	ISET <sub>i</sub> , i = 1, NSETS where NSETS of Card 53.1 is the number of sets of load equations and must be ≤ 10. ISET <sub>i</sub> contains the number of loads in the ith load set. (ISET <sub>i</sub> ≤ 100)
6-10	ISET <sub>2</sub>		
⋮	⋮		
46-50	ISET <sub>10</sub>		

**Card Set 54.0-Load Set Card**

COLS.	KEYWORD/ VARIABLE	FORMAT	DESCRIPTION
1-10	LOAD	A10	A keyword indicating that the Load Set to be processed follows.
11-15	JSET	I5	The load set number. (JSET ≤ NSETS)

Card set 54.0 specifies the load set from which subsequent items will be sorted. If a LOAD card is not included, JSET = 1 is assumed.

**Card Set 55.0-Static Card**

COLS.	KEYWORD/ VARIABLE	FORMAT	DESCRIPTION
1-10	STATIC	A10	A keyword requesting the processing of the static-elastic solution for a particular Load Set.
11-15	JSET	I5	The load set number. (JSET ≤ NSETS)

Card set 55.0 specifies that subsequent items to be sorted will be from the static-elastic solution for the load set JSET.

### Card Set 56.0-Pair Card

COLS.	KEYWORD/ VARIABLE	FORMAT	DESCRIPTION
1-10	<u>PAIR</u>	A10	A keyword requesting that standard and static-elastic responses be paired on the output file, "NEWTPE"

Card set 56.0 causes SORTQLS to sort the same specified items from both the standard and static-elastic solutions (same load set) and write them on the magnetic file defined by "NEWTPE" (card set 52.0), immediately following one another so they may easily be plotted on one frame. This feature is turned off by the SEPAR (card set 57.0) card.

### Card Set 57.0-Separate Card

COLS.	KEYWORD/ VARIABLE	FORMAT	DESCRIPTION
1-10	<u>SEPARate</u>	A10	A keyword requesting the separation of standard and static-elastic responses.

Card set 57.0 will turn off card set 56.0 and will separate the standard and the static-elastic solutions.

### Card Set 58.0-Scale Card

COLS.	KEYWORD/ VARIABLE	FORMAT	DESCRIPTION
1-10	<u>SCALE</u>	A10	A keyword introducing SORTQLS Scale factors.
11-20	SCALX	E10.0	The frequencies will be multiplied by SCALX before being written on the magnetic file "NEWTPE", (see Card Set 51) (SCALX > 0)
21-30	SCALY	E10.0	The sorted items will be multiplied by SCALY. (SCALY > 0)

### Card Set 59.0-Sort Card

#### Card 59.1-Sort Q, L, S, or R

COLS.	KEYWORD/ VARIABLE	FORMAT	DESCRIPTION
1-10	<u>Sort</u>	A10	A keyword requesting the sorting of item(s) from magnetic file "INTAPE".
11-20	<u>Q, L, S,</u> or <u>R</u>	A10	A variable indicating which item to sort from load set JSET. <u>Q's</u> = sort the generalized coordinates. <u>Loads</u> = sort the load transfer functions. <u>Spectra</u> = sort the output spectrum. <u>Rms</u> = sort the root mean square values.
21-25	NSORT	I5	The number of items to be sorted. (NSORT ≤ 100) If NSORT = 0 all available items of the type specified above will be sorted (retained) and written on file "NEWTPE".

Card 59.1 is repeated for each variable which the user wishes to sort.

Omit card 59.2 if NSORT of card 59.1 = 0.

COLS.	KEYWORD/ VARIABLE	FORMAT	DESCRIPTION
1-5	NUM <sub>1</sub>	14I5	NUM <sub>i</sub> ; i = 1, NSORT where NSORT is from Card 59.1.  The specific numbers of items that are to be sorted (retained) as specified by the item type (Q, L, S, or R) on Card 59.1.
6-10	NUM <sub>2</sub>		
⋮	⋮		
	NUM <sub>NSORT</sub>		Repeat the card with 14 numbers per card until all elements are defined.

**Card Set 60.0-Sort A<sup>ll</sup>**

COLS.	KEYWORD/ VARIABLE	FORMAT	DESCRIPTION
1-10	<u>SORT</u>	A10	A keyword requesting the sorting of items from file "INTAPE".
11-20	<u>All</u>	A10	This variable indicates what type of sorting will take place.  <i>All</i> = will sort all $\bar{A}$ 's, loads, and output spectra, from all load sets (both standard and static-elastic solutions if present).

The SORTQLS magnetic output file will contain:

Q's for standard solution.  
Q's for static-elastic solution if present.

Loads for standard solution.	} repeated NSETS times
Loads for static-elastic solution.	
Spectra for standard solution.	} repeated NSETS times
Spectra for static-elastic solution.	

and, if IPLRMS = 1 (card 4.3 of FINDRMS)

$\bar{A}$ values for standard solution.	} repeated NSETS times
$\bar{A}$ values for static-elastic solution.	

**Card Set 61.0-SORTQLS End Card**

COLS.	KEYWORD/ VARIABLE	FORMAT	DESCRIPTION
1-10	<u>\$END</u>	A10	A keyword which terminates the SORTQLS processing.

### 6.3.5 PROGRAM PLOTQLS

All of the cards read by the third primary overlay PLOTQLS are identified by a code word beginning in column one and have fixed field input of the required numbers.

The recognized code words and possible parameters are shown in the following listing in alphabetical order. The keyword parameters are underlined and only the capital letter variables are relevant.

<u>Card set</u>	<u>Keyword</u>	<u>Variables</u>
71	<u>DEFAULT</u>	Use default grid limits
70	<u>GRID</u>	Set grid limits to XMIN, XMAX, YMIN, and YMAX
72	<u>LABEL</u>	Use miscellaneous plot labeling information
75	<u>LINEAR</u>	Requests a linear-linear grid on the plot frame
65	<u>LOAD</u>	Load set number JSET
76	<u>LOG-Log</u>	Requests a log-log grid on the plot frame
67	<u>PAIR</u>	Pairs the standard and static-elastic solutions
		Plot the requested item:
77	<u>PLOT</u>	<u>Q</u> Plots the generalized coordinates
		<u>L</u> Plots the load transfer function
		<u>S</u> Plots the output spectrum
		<u>R</u> Plots the RMS load values
78	<u>PLOT</u>	<u>A</u> Plots all items
64	<u>RESTART</u>	Restart with MDOF, MFREQ, MSTATE, MPLTPE, MRTAPE, NGROUP, and NSETS
69	<u>SCALE</u>	Scales the axes with SCALX and SCALY
68	<u>SEPARATE</u>	Separates the standard and static-elastic solutions
66	<u>STATIC</u>	Plot the static-elastic solution of load set JSET
63	<u>TITLE</u>	Miscellaneous printout labeling information
73	<u>X-AXIS</u>	Set x-axis label

74	<u>Y-AXIS</u>	Set y-axis label
79	<u>\$END</u>	Terminate PLOTQLS processing

General information on the processing of the third primary overlay PLOTQLS is presented in the following paragraphs.

The cards **DEFAULT**, **GRID**, **LABEL**, **LOAD**, **PAIR**, **RESTART**, **SCALE**, **SEPARate**, **STATIC**, and **TITLE** simply set options or give directions to PLOTQLS—*no immediate action is taken*.

The **PLOT** card (card sets 70.0 and 71.0) causes PLOTQLS to read the input magnetic file, sort the items specified, and prepare the plots. Therefore, all desired options must be declared *before* the **PLOT** card is input.

PLOTQLS will continue to process data cards and sort the specified items until it reads the **\$END** card (card set 79.0) which will terminate the PLOTQLS processing.

The option cards **DEFAULT**, **GRID**, **LOAD**, **PAIR**, **SCALE**, **SEPARate**, **STATIC**, and **TITLE** may be inserted any number of times. The last specified card set will remain in effect.

The flow of PLOTQLS card input data is displayed in figure 7.

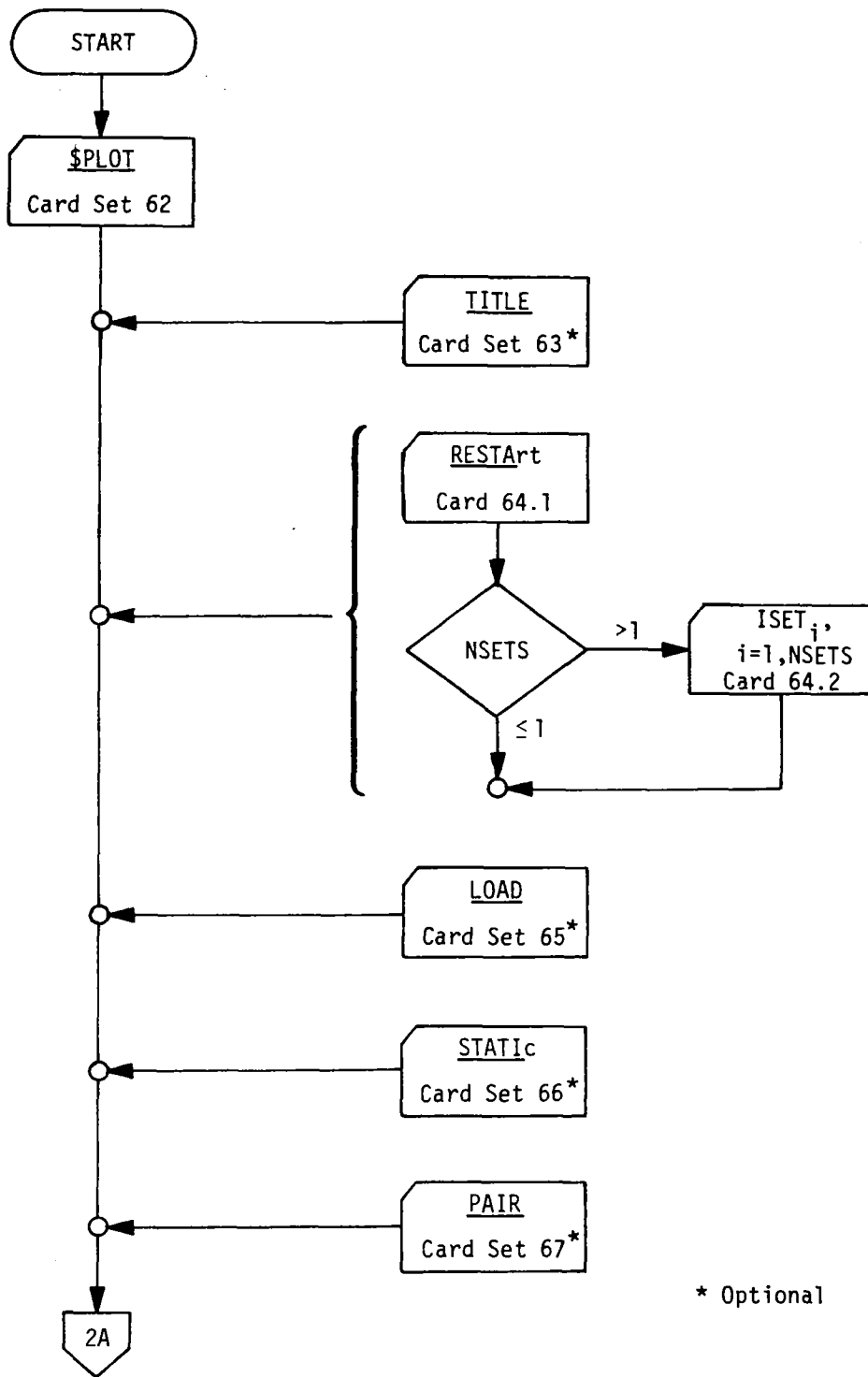

Figure 7.—Flow of PLOTQLS Card Input Data

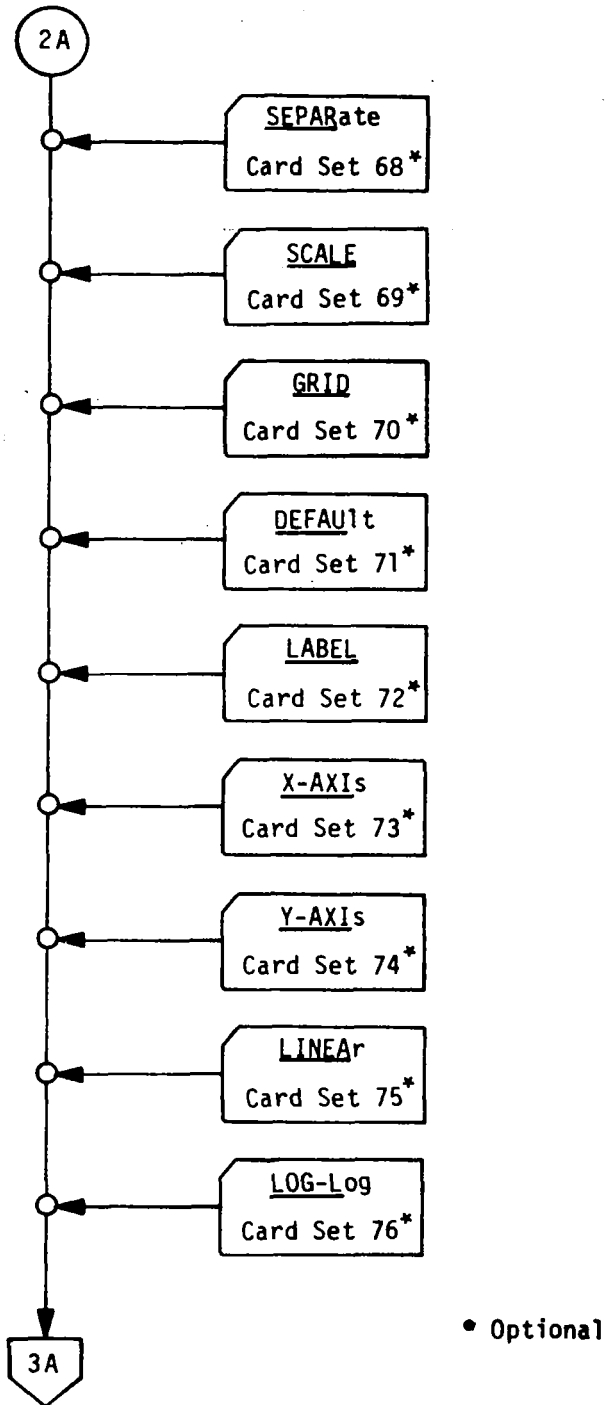

Figure 7.—(Continued)



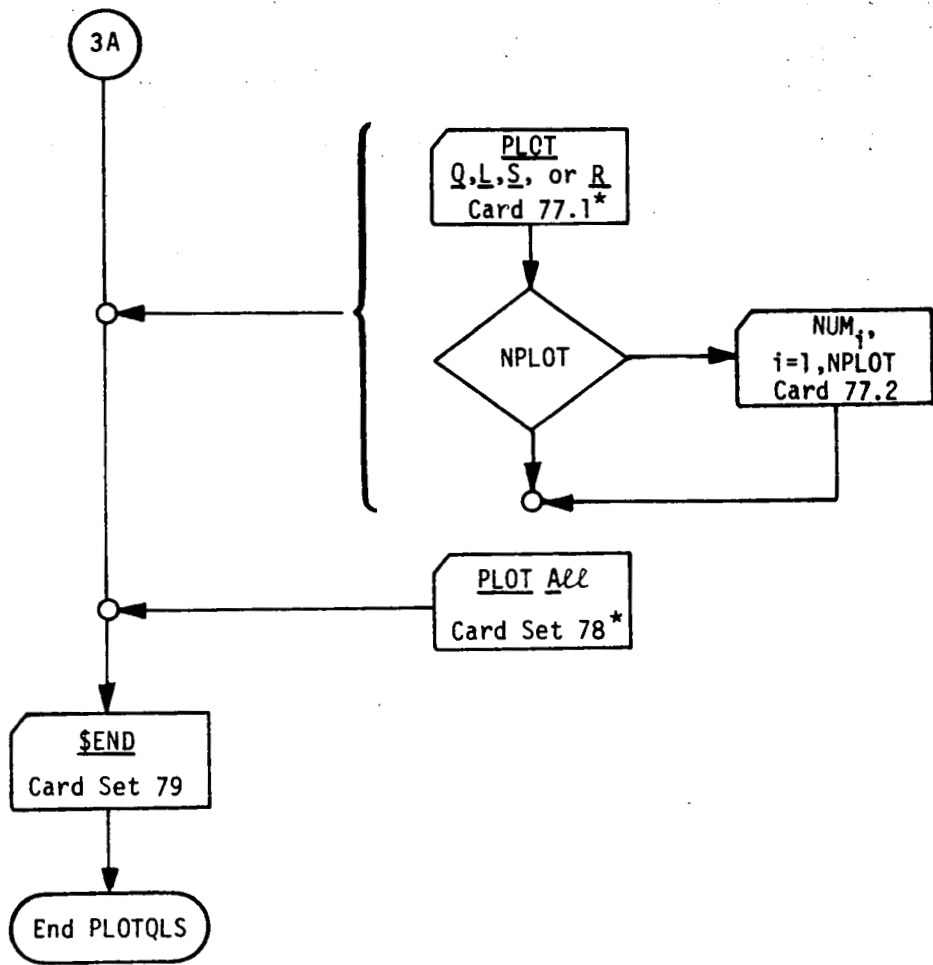

Figure 7.—(Concluded)

### Card Set 62.0-PLOTQLS Link Call Card

COLS.	KEYWORD/ VARIABLE	FORMAT	DESCRIPTION
1-10	<u>\$PLOTqls</u>	A10	This card initializes the call to the third primary overlay, PLOTQLS. It introduces PLOTQLS data cards. PLOTQLS will perform the required plotting and then will return control to the main overlay after Card Set 79 has been read.
11-60	description	5A10	Miscellaneous labeling information for plot identification. It should include the user's name, phone number, mail stop, and organization.

### Card Set 63.0-Title Card

COLS.	KEYWORD/ VARIABLE	FORMAT	DESCRIPTION
1-10	<u>TITLE</u>	A10	A keyword indicating a TITLE card.
11-70	description	6A10	Any miscellaneous title description.

Card set 63.0 will be read, printed on the output file, and ignored.

### Card Set 64.0-Restart L221 (TEV156)

Card set 64.0 will restart L221 (TEV156) to sort a FINDRMS tape from a previous run. It is needed to specify information to PLOTQLS which is normally passed through labeled common from FINDRMS.

### Card 64.1-Restart Card Variables

COLS.	KEYWORD/ VARIABLE	FORMAT	DESCRIPTION
1-10	<u>RESTART</u>	A10	A keyword introducing a card of problem size variables.
11-15	MDOF	I5	The number of degrees of freedom. (MDOF $\leq$ 100)
16-20	MFREQ	I5	The number of frequencies. (MFREQ $>$ 1)
21-25	MSTATE	I5	The static-elastic solution. = 0 <u>no</u> static-elastic solution was previously found. = 1 a static-elastic solution was previously found.
26-35	MPLTPE	A10	The magnetic file "IPLTPE" previously defined by FINDRMS. If MPLTPE is <u>not</u> to be defined, then leave the variable blank, otherwise, the magnetic file name must be a left-justified, 1 to 7 character file, name with the first character being alphabetic.
36-45	MRTAPE	A10	The magnetic file which contains the load transfer functions. If MRTAPE is <u>not</u> to be defined, then leave the variable blank, otherwise, the magnetic file name must be a left-justified, 1 to 7 character file name, with the first character being alphabetic.
46-50	NGROUP	I5	The number of items contained on the magnetic file defined by MPLTPE for each frequency. (NGROUP $\geq$ 3)
51-55	NSETS	I5	The number of sets of load equations. (NSETS $\leq$ 10)
56-60	ISET	I5	If NSETS = 1, the number of loads in load set 1. If NSETS is greater than 1 then this field is to be left blank.

Read card 64.2 for the number of loads in each load set if NSETS of card 64.1 > 1.

**Card 64.2-Number of Loads in Each Load Set**

COLS.	KEYWORD/ VARIABLE	FORMAT	DESCRIPTION
1-5	ISET <sub>1</sub>	I015	ISET <sub>i</sub> , i = 1, NSETS where NSETS of Card 72.1 is the number of sets of load equations and must be ≤ 10.  ISET <sub>i</sub> contains the number of loads in the ith load set. (ISET <sub>i</sub> ≤ 100)
6-10	ISET <sub>2</sub>		
⋮	⋮		
46-50	ISET <sub>10</sub>		

**Card Set 65.0-Load Set Card**

COLS.	KEYWORD/ VARIABLE	FORMAT	DESCRIPTION
1-10	LOAD	A10	A keyword indicating that the Load Set to be processed follows.
11-15	JSET	I5	The load set number. (JSET ≤ NSETS)

Card set 65.0 specifies the load set from which subsequent items will be plotted. If a LOAD card is not included, JSET = 1 is assumed.

**Card Set 66.0-Static Card**

COLS.	KEYWORD/ VARIABLE	FORMAT	DESCRIPTION
1-10	STATIC	A10	A keyword requesting the processing of the static-elastic solution for a particular load set.
11-15	JSET	I5	The load set number. (JSET ≤ NSETS)

Card set 66.0 specifies that subsequent items to be plotted will be from the static-elastic solution of load set number JSET.

### Card Set 67.0-Pair Card

COLS.	KEYWORD/ VARIABLE	FORMAT	DESCRIPTION
1-10	<u>PAIR</u>	A10	A keyword requesting that standard and static-elastic responses be paired on the plots.

Card set 67.0 causes PLOTQLS to plot the same specified items from both the standard and static-elastic solutions (of the same load set) on the same frame. This feature is negated by the SEPARate card (card set 68.0).

### Card Set 68.0-Separate Card

COLS.	KEYWORD/ VARIABLE	FORMAT	DESCRIPTION
1-10	<u>SEPARate</u>	A10	A keyword requesting the separation of standard and static-elastic responses.

Card set 68.0 will negate the PAIR option of card set 67.0, and will separate the standard and static-elastic solutions.

### Card Set 69.0-Scale Card

COLS.	KEYWORD/ VARIABLE	FORMAT	DESCRIPTION
1-10	<u>SCALE</u>	A10	A keyword introducing PLOTQLS scalars.
11-20	SCALX	E10.0	The frequencies will be multiplied by SCALX before being plotted. (SCALX > 0)
21-30	SCALY	E10.0	The plot items will be multiplied by SCALY before being plotted. (SCALY > 0)

### Card Set 70.0-Grid Card

COLS.	KEYWORD/ VARIABLE	FORMAT	DESCRIPTION
1-10	GRID	A10	A keyword introducing PLOTQLS grid limits.
11-20	XMIN	E10.0	The minimum x-axis grid limit.
21-30	XMAX	E10.0	The maximum x-axis grid limit.
31-40	YMIN	E10.0	The minimum y-axis grid limit.
41-50	YMAX	E10.0	The maximum y-axis grid limit.

Card set 70.0 establishes the limits of the plot card. If a GRID card is not input, the grid limits will be the lowest and highest frequencies and the minimum and maximum of the curves plotted on each frame. If a negative limit is specified, the program will revert to the default for that particular limit.

### Card Set 71.0-Default Card

COLS.	KEYWORD/ VARIABLE	FORMAT	DESCRIPTION
1-10	DEFAULT	A10	The keyword indicating that PLOTQLS will find its own grid limits for each frame. It also negates the GRID option of Card Set 70.

### Card Set 72.0-Label Card

COLS.	KEYWORD/ VARIABLE	FORMAT	DESCRIPTION
1-10	LABEL	A10	A keyword introducing a plot label.
11-50	description	4A10	Any miscellaneous plot frame labeling information.

The 40 label characters will be placed in the plot frame title block *below* the message(s) listed. Two label cards may be used.

GEN COORD  
LOAD TRANS  
SPECTRUM  
RMS

NO. \_\_\_\_\_ LOAD SET \_\_\_\_\_

{ Note: The y-axis label is substituted for this line if input.

FROM THE STATIC-ELASTIC SOLUTION }  
WITH THE STATIC-ELASTIC SOLUTION }

40 characters of label card 1

40 characters of label card 2

**Card Set 73.0-X-Axis Label Card**

COLS.	KEYWORD/ VARIABLE	FORMAT	DESCRIPTION
1-10	<u>X-AXIS</u>	A10	A keyword introducing an x-axis label.
11-30	description	2A10	Miscellaneous information to label the x-axis of the plot frame. The default x-axis label is FREQUENCY.

**Card Set 74.0-Y-Axis Label Card**

COLS.	KEYWORD/ VARIABLE	FORMAT	DESCRIPTION
1-10	<u>Y-AXIS</u>	A10	A keyword introducing a y-axis label.
11-50	description	4A10	Miscellaneous information to label the y-axis of the plot frame.

The y-axis label will serve as the first line in the title block. The default y-axis label and title line are:

GEN COORD LOAD TRANS SPECTRUM RMS	}	NO. _____ LOAD SET _____
--	---	--------------------------

**Card Set 75.0-Linear Grid Card**

COLS.	KEYWORD/ VARIABLE	FORMAT	DESCRIPTION
1-10	<u>LINEAR</u>	A10	A keyword requesting a linear - linear grid on the plot frame. Note: This is the default grid type.

**Card Set 76.0-Log Grid Card**

COLS.	KEYWORD/ VARIABLE	FORMAT	DESCRIPTION
1-10	<u>LOG-Log</u>	A10	A keyword requesting a log - log grid on the plot frame. Note: The default grid type is linear - linear.

**Card Set 77.0-Plot Card**

**Card 77.1-Plot Q, L, S, or R**

COLS.	KEYWORD/ VARIABLE	FORMAT	DESCRIPTION
1-10	<u>PLOT</u>	A10	A keyword requesting the plotting of item(s) from magnetic file "INTAPE".
11-20	<u>Q</u> , <u>L</u> , <u>S</u> , or <u>R</u>	A10	A keyword indicating which item to plot from load set JSET.  <u>Q</u> 's = plot the generalized coordinates. <u>L</u> oads = plot the load transfer functions. <u>S</u> pectra = plot the output spectra. <u>R</u> ms = plot the root mean square values.
21-25	<u>NPLOT</u>	I5	The number of items to be plotted.  (NPLOT ≤ 100)  If NPLOT = 0 all available items of the type specified above will be plotted.

Card 77.1 is repeated for each variable the user wishes to plot.

Omit card 77.2 if NPLOT of card 77.1 = 0.

COLS.	KEYWORD/ VARIABLE	FORMAT	DESCRIPTION
1-5	NUM <sub>1</sub>	14I5	NUM <sub>i</sub> ; i = 1, NPLOT  where NPLOT is from Card 77.1.  The specific numbers of items that are to be plotted as specified by the item type (Q, L, S, or R) on Card 77.1.
6-10	NUM <sub>2</sub>		
⋮	⋮		
	NUM <sub>NPLOT</sub>		Repeat the card with 14 numbers per card until all elements are defined.



**Card Set 78.0-Plot A ll**

COLS.	KEYWORD/ VARIABLE	FORMAT	DESCRIPTION
1-10	<u>PLOT</u>	A10	A keyword requesting the plotting of items from magnetic file "INTAPE".
11-20	<u>A ll</u>	A10	This keyword requests that all Q's, loads, and output spectra, from all load sets (both standard and static-elastic solutions if present).

The plots will be in the following order:

Q's for standard solution.

Q's for static-elastic solution if present.

Loads for standard solution.

Loads for static-elastic solution.

} repeated  
NSETS times

Spectra for standard solution.

Spectra for static-elastic solution.

} repeated  
NSETS times

and, if IPLRMS = 1 (card 4.3 of FINDRMS)

$\bar{A}$  values for standard solution.

A values for static-elastic solution.

} repeated  
NSETS times

**Card Set 79.0-PLOTQLS End Card**

COLS.	KEYWORD/ VARIABLE	FORMAT	DESCRIPTION
1-10	<u>\$END</u>	A10	A keyword which terminates the PLOTQLS processing.

**Card Set 80.0-Termination of L221 (TEV156)**

COLS.	KEYWORD/ VARIABLE	FORMAT	DESCRIPTION
1-10	<u>\$QUIT</u>	A10	A keyword which terminates the L221 (TEV156) program.

Requirements or Function	Keywords and/or Variables	Card Format	Reference Card Set (CS)
	<u>\$FRE</u> quency	A10	1.1
	<u>\$TIT</u> le	A10	1.2
	<u>\$COR</u> MAXCOR	A10	1.3
	<u>\$CHEC</u> k	A10	1.4
	<u>\$FIND</u> rms	A10	2.0
	BLOCK I -- Options and Constant Data		
	LABEL	7A10	3.0
Options	NDOF    NFREQ    NPAN    NKVAL    NFORC    NDOFD	6I5	4.1
Options	IFREQ    ISPEC    ISTATE    IFDBAK    IDAMP    INTZRO	6I5	4.2
Output Options	IPRINT    IRMSPR    IPUNCH    ICKPRT    IPLRMS    LPDOF	6I5	4.3
I/O Files	INTAPE    IPLTPE    IRTAPE    IFTAPE	4A10	4.4
Wagner Function	A <sub>1</sub> B <sub>1</sub> C <sub>1</sub> D <sub>1</sub> α <sub>1</sub> β <sub>1</sub> γ <sub>1</sub>	7E10	5.1
Küssner Function	A <sub>2</sub> B <sub>2</sub> C <sub>2</sub> D <sub>2</sub> α <sub>2</sub> β <sub>2</sub> γ <sub>2</sub>	7E10	5.2
Input Const.	Z    VEL    L    C    TABFS    TABS    FDSCAL	7E10	6.0
ISTATE = 2; CS 4.2	Columns to be zeroed out for static-elastic solution	14I5	7.1
NDOFD > 0; CS 4.1	Columns and rows of Equations of Motion and columns of Load Equations to be zeroed out	14I5	7.2
ISPEC = 2; CS 4.2	κ    η	2E10	8.1
ISPEC < 0; CS 4.2 IFTAPE undefined CS 4.4	Tabular input spectrum frequencies	7E10	8.2

Requirements or Function	Keywords and/or Variables	Card Format	Reference Card Set (CS)
ISPEC < 0; CS 4.2 NFORC = 1; CS 4.1 IFTAPE undefined; CS 4.4	Single tabular input spectrum	7E10	8.3
ISPEC < 0; CS 4.2 NFORC ≥ 2; CS 4.1 IFTAPE undefined CS 4.4	Multiple tabular input spectrum	7E10	8.4
IDAMP = 0 CS 4.2	$g_{SD}$	1E10	9.1
IDAMP > 0 CS 4.2	Structural damping for each degree of freedom	7E10	9.2
IFDBAK = 1 CS 4.2	Standard Feedback Coefficients	7E10	10.0 - 10.5
IFDBAK = 2 CS 4.2	Special Feedback Coefficients	7E10	10.6 - 10.8
IFREQ = -1 CS 4.2	Frequencies (cps)	7E10	11.1
IFREQ = 0 CS 4.2	Frequencies (rad/sec)	7E10	11.2
IFREQ > 0 CS 4.2	First frequency and an increment (cps)	2E10	11.3
LPDOF > 0 CS 4.3	Frequencies where loads/degree of freedom is printed	7E10	11.4

Requirements or Function	Keywords and/or Variables	Card Format	Reference Card Set (CS)
	<u>SEQUATION</u>	A10	12.0
If tape from DYLOFLX system	<u>DYLOFLX</u>	A10	13.1
If matrices on cards, or INTAPE not from DYLOFLX	Choose non-null equations of motion matrices	1015	13.2
IFDBAK $\geq$ 1 CS 4.2	Choose non-null feedback matrices	615	13.3
Matrices on cards	Equations of motion matrices and associated frequencies (if any) or equations of motion feedback matrices	7E10	14.0 - 30.0

Requirements or Function	Key Words and/or Variables	Card Format	Reference Card Set (CS)
	<u>\$LOAD</u> NLD    ICORR $\bar{c}$ LDTAPE	A10,215, E10,A10	31.0
ICORR > 0; CS 31.0 NFORC = 1; CS 4.1	Load number. Other load numbers to correlate with first item	1115	32.0
If tape from DYLOFLX system	<u>DYLOE1x</u>	A10	33.1
If matrices on cards, or LDTAPE not from DYLOFLX	Choose non-null load equation matrices	1015	33.2
IFDBAK > 1 CS 4.2	Choose non-null feedback matrices	615	33.3
Matrices on cards	Load equation matrices or load equation feedback matrices	A10	34.0 - 38.0
	<u>\$END</u>		

Requirements or Function	Keywords and/or Variables	Reference Card Set (CS)
	<u>\$SORTq</u> ls	50.0
	<u>TITLE</u> - Title description	51.0
	Tape card	52.0
	Restart capability if generalized coordinates and load frequency response tape previously saved	53.0
Optional	<u>LOAD</u> JSET	54.0
	<u>STATIC</u> JSET	55.0
	<u>PAIR</u>	56.0
	<u>SEPARate</u>	57.0
	<u>SCALE</u> - Scale card A5,5X; E10.0; E10.0	58.0
	<u>SORT</u> - Items and number of items to sort	59.1
NSORT > 0 CS 59.1	Specific numbers of items to be sorted	59.2
	<u>SORT All</u>	60.0
	<u>\$END</u>	61.0

Requirements or Functions	Keywords and/or Variables	Reference Card Set (CS)
	<u>\$PLOTqls</u> User's name/phone number/mail stop/orgainzation	62.0
	<u>TITLE</u> - Title description	63.0
	Restart capability if generalized coordinates and load frequency response tape previously saved	64.0
	Specific items and controls for plotting	65.0 - 78.0
	<u>\$END</u>	79.0
	<u>\$QUIT</u> - Terminates the L221 (TEV156) program	80.0

## 6.4 MAGNETIC FILES INPUT DATA

The input matrices to the L221 (TEV156) program can be obtained from three magnetic (tape or disk) files. These files, "INTAPE", "LDTAPE", and "IFTAPE", are discussed in sections 6.4.1, 6.4.2, and 6.4.3, respectively.

The use of these magnetic files to contain the input matrices will depend on whether or not they have been defined through the use of either the tape option card (see card 4.4 of sec. 6.3) or the load instruction card (see card set 31.0 of sec. 6.3). If any of the magnetic files have not been defined, then the associated input matrices will be read from input cards.

All input magnetic files are in the READTP/WRTETP format.<sup>1</sup>

### 6.4.1 "INTAPE"

By default FINDRMS will read the equations of motion matrices in card sets 14.0 through 30.0 (sec. 6.3). If, however, the user specifies a file name in the variable INTAPE on card 4.4, the matrices will read from magnetic file "INTAPE" (see fig. 8) in the READTP/WRTETP format.

FINDRMS rewinds "INTAPE" before attempting to read any matrices. Several input parameters determine which matrices are contained on "INTAPE". These parameters are NDOF, NPAN, and KIVAL of card 4.1; IFDBAK of card 4.1 and the non-null matrix indicators in cards 13.2 and 13.3.

For the matrices appearing in figure 8:

{HEADER} Will be present only if the keyword DYLOFLEX was read in card 13.1

{S<sub>1</sub>}, {S<sub>2</sub>}, ..., {S<sub>6</sub>} Will not be present if IFDBAK = 0 on card 4.2

{f<sub>λ</sub>} and {φ̃} Will replace {C<sub>3</sub>} if NPAN > 0 on card 4.1

{FREQM} and the frequency-dependent matrices ([M<sub>4</sub>], [M<sub>5</sub>], [M<sub>6</sub>], {C<sub>3</sub>}, or {φ̃}) will not be present if NKVAL = 0.

The equations of motion are followed on "INTAPE" by an end-of-file. If LDTAPE in card set 31.0 is defined with the same name as INTAPE, FINDRMS will skip the end-of-file and read the load equations from the second file of "INTAPE". Additional load sets may appear in logical files three, four, etc.

---

<sup>1</sup>Clemmons, R. E.: *Programming Specifications for Modules of the Dynamic Loads Analysis System to Interface With FLEXSTAB*. NASA contract NAS1-13918; BCS-G0701, September 1975. (Internal Document.)



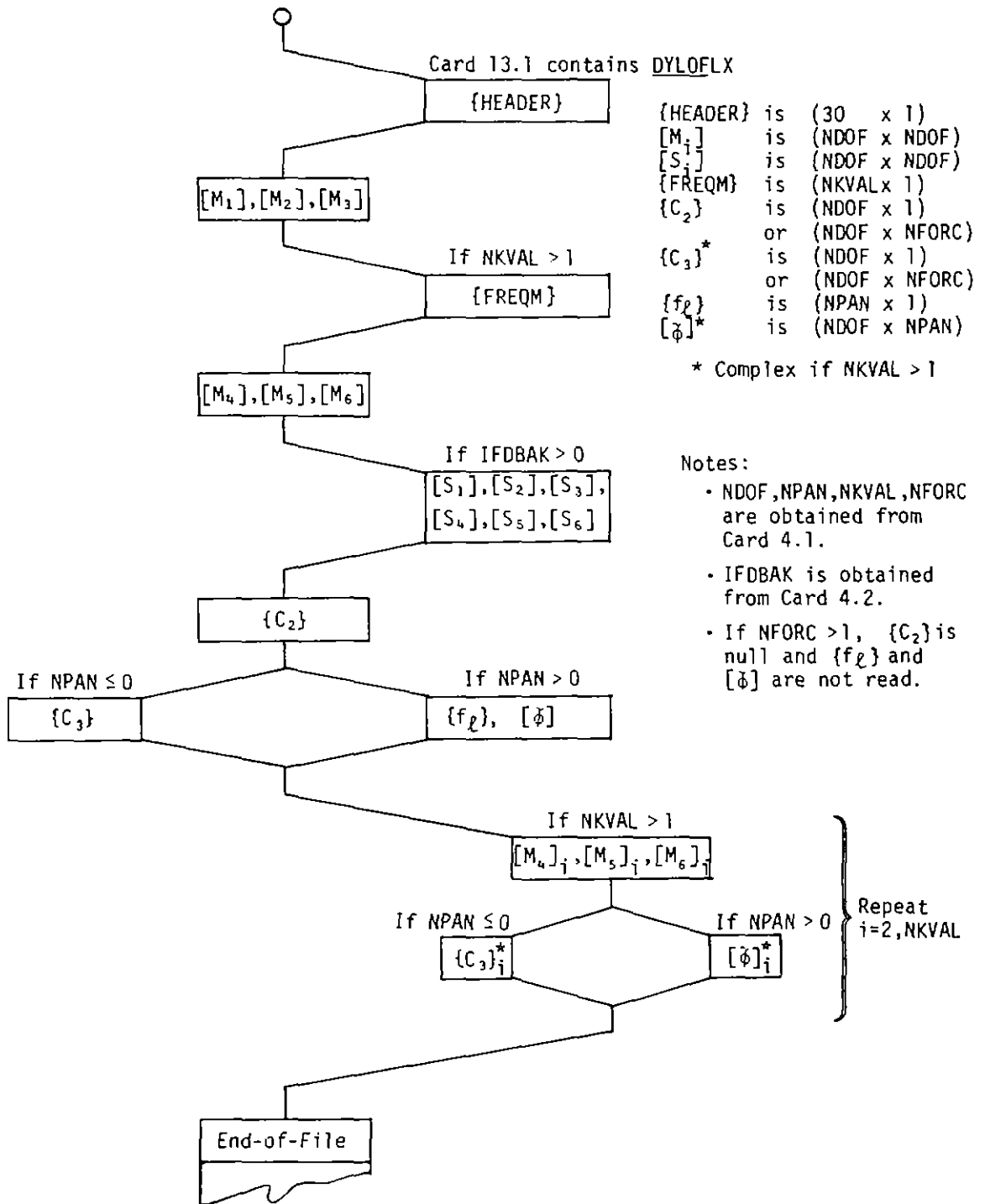

Figure 8.—Contents of the File "INTAPE"

The contents of the DYLOFLEX header matrix are described in the following listing.

<u>Position</u>	<u>Format</u>	<u>Description</u>
1	A10	Contains the DYLOFLEX header keyword, 7HDYLOFLX
2	A10	Program name/version number of the program that created the tape
3	A10	Date of the run that created the tape, 10H yr/mo/da
4	I10	Contains the number of degrees of freedom, NDOF
5	I10	Contains the number of load equations, NLD
6	I10	Contains the number of gradual penetration panels, NPAN
7	I10	Contains the number of k values used for the multiple frequency-dependent matrices option, NKVAL
8		Not used
9	E10.0	Contains the velocity (true air speed), VEL
10-20		Not used
21	I10	NULMAT (1); if > 0, [M <sub>1</sub> ] will be read
22	I10	NULMAT (2); if > 0, [M <sub>2</sub> ] will be read
23	I10	NULMAT (3); if > 0, [M <sub>3</sub> ] will be read
24	I10	NULMAT (4); if > 0, [M <sub>4</sub> ] will be read
25	I10	NULMAT (5); if > 0, [M <sub>5</sub> ] will be read
26	I10	NULMAT (6); if > 0, [M <sub>6</sub> ] will be read
27	I10	NULMAT (7); if > 0, [C <sub>2</sub> ] will be read
28	I10	NULMAT (8); if > 0, [C <sub>3</sub> ] will be read
29	I10	NULMAT (9); if > 0, [f <sub>2</sub> ] will be read
30	I10	NULMAT (10); if > 0, [ϕ̃] will be read

**Note:** The program will check the values given for NDOF, NLD, NPAN, NKVAL, and VEL in the DYLOFLEX header matrix against the same variables read from cards. All values not compatible will cause a fatal error, except VEL which causes a warning error.

#### 6.4.2 "LDTAPE"

By default, FINDRMS will read the load equations in card sets 34.0 through 48.0 (sec. 6.3). If, however, the user specifies a file name in the variable LDTAPE on card set 31.0, the matrices corresponding to those card sets will be read from magnetic file "LDTAPE" (see fig. 9) in READTP/WRTETP format.

FINDRMS will rewind "LDTAPE" if LDTAPE does not have the same name as INTAPE (card 4.4) or LDTAPE of the previous load set. Otherwise, FINDRMS will skip one end-of-file mark and try to read the set of load equation matrices from the next logical file on "LDTAPE".

Several input parameters determine which matrices are contained on LDTAPE. These parameters are NDOF, NPAN, and NKVAL of card 4.1; IFDBAK of card 4.2; and the non-null matrix indicators in cards 33.2 and 33.3.

For the matrices appearing in figure 9:

{HEADER} Will be present only if the DYLOFLEX keyword was encountered in card 33.1. The contents are similar to those appearing on INTAPE described in section 6.4.1

$[\bar{S}_1], [\bar{S}_2], \dots, [\bar{S}_6]$  Will *not* be present if IFDBAK = 0

$[\bar{\phi}]$  Will replace  $\{\bar{C}_3\}$  if NPAN > 0

The frequency-dependent matrices ( $[\bar{M}_4]$ ,  $[\bar{M}_5]$ ,  $[\bar{M}_6]$ ,  $\{\bar{C}_3\}$ , or  $[\bar{\phi}]$ ) will *not* be present if NKVAL = 0.

#### 6.4.3 "IFTAPE"

When ISPEC < 0 on card 4.2, FINDRMS will read the tabular input spectrum(s) on card 8.3 or 8.4 (sec. 6.3). If, however, the user also specifies a file name in the variable IFTAPE on card 4.4, the tabular input spectrum(s) will be read from "IFTAPE" (see fig. 10) in the READTP/WRTETP format.

FINDRMS will rewind "IFTAPE" and then read one matrix for each spectrum required. A spectrum is needed for each combination of (I,J) where I = 1, NFORC and J = I, NFORC. Because of symmetry, only the upper right triangular combinations are input. Input row 1 with J = 1, NFORC; then row 2 with J = 2, NFORC; then row 3 with J = 3, NFORC; ...; and finally row NFORC with J = NFORC.

Each spectrum contains NSP elements, but because the elements are complex, the array must be of size 2NSP x 1.

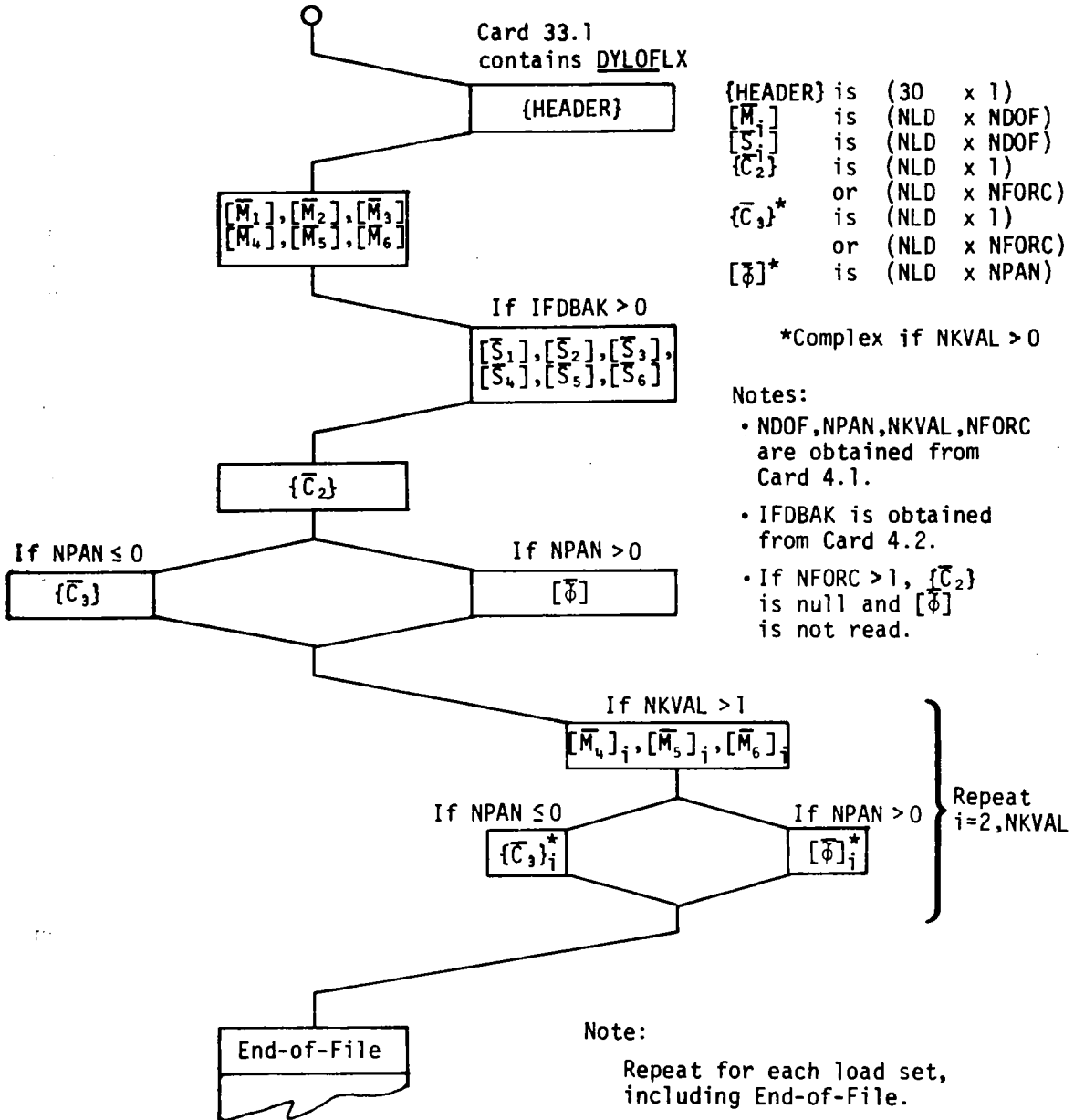

Figure 9.—Contents of the File "LDTAPE"

<u>Size</u>	<u>Matrix</u>
NSP x 1	{FREQS}
2NSP x 1	{PHIOS} <sub>1,1</sub>
2NSP x 1	{PHIOS} <sub>1,2</sub>
	⋮
2NSP x 1	{PHIOS} <sub>i,j</sub>
	⋮
2NSP x 1	{PHIOS} NFORC-1,NFORC
2NSP x 1	{PHIOS} NFORC,NFORC
	End-of-File

where

NSP = |ISPEC| = the number of frequencies defining the input spectrum

NFORC = the number of excitation forces

Figure 10.—Contents of the File "IFTAPE"

## 6.5 OUTPUT DATA

### 6.5.1 PRINTED OUTPUT DATA

The input data for each of the L221 (TEV156) modules will be echo-printed except where noted; i.e., printing of FINDRMS input matrices is optional. Other printed output matrices will be discussed by module.

#### Program FINDRMS

The RMS values and zero crossings will be printed for each FINDRMS solution. Optionally, the following can also be printed.

- Generalized coordinates, load transfer functions, and output spectrum at each frequency (see option IPRINT of card 4.3, sec. 6.3)
- Correlation between different loads (see option ICORR of card set 30.0)
- Input matrices; load equations and equations of motion (see option ICKPRT of card 4.3)
- Matrices of intermediate calculations for program checkout (see option ICKPRT of card 4.3)
- RMS load values,  $\bar{A}$ , for the last IRMSPR frequencies (see option IRMSPR of card 4.3)

#### Program SORTQLS

After each set of card input data, SORTQLS will print one line for each item it writes on magnetic file "NEWTPE". The messages are intended to show the program's progress if a failure occurs.

#### Program PLOTQLS

After each set of card input data, PLOTQLS will print a one line message for each item plotted. The messages are intended to show the program's progress if a failure occurs.

### 6.5.2 MAGNETIC FILES OUTPUT DATA

FINDRMS will write on as many as three magnetic files; "IPTLPE", "IRTAPE" (figs. 11 and 12, respectively), and "SCRATCH". SORTQLS, however, will only write on one magnetic file, "NEWTPE" (fig. 13). PLOTQLS writes on magnetic file "TAPE99".

All matrices contained on these magnetic files are written by the WRTETP subroutine.<sup>1</sup>

<sup>1</sup>Clemmons, R. E.: *Programming Specifications for Modules of the Dynamic Loads Analysis System to Interface With FLEXSTAB*. NASA Contract NAS1-13918; BCS-G0701, September 1975. (Internal Document.)

## "IPLTPE"

The magnetic file "IPLTPE" is written when it is requested on card 4.4 of FINDRMS. "IPLTPE", if defined, will contain the arrays calculated in FINDRMS (fig. 11).

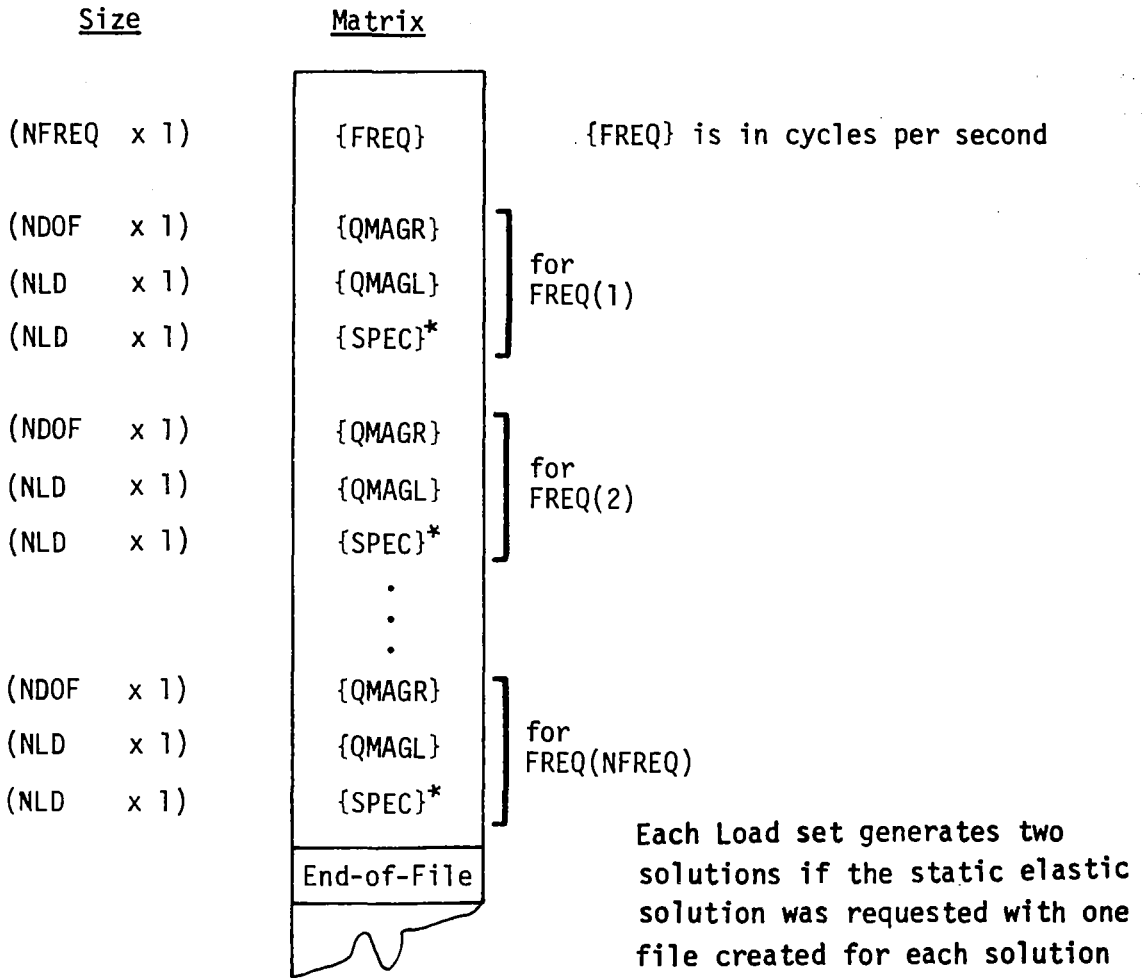

\* If IPLRMS = 1 on Card 4.3,  $\{\bar{A}\}$  which contains the  $\bar{A}$  values will be written on "IPLTPE" immediately after {SPEC} for each frequency.

Figure 11.—Contents of the File "IPLTPE"

## "IRTAPE"

The magnetic file "IRTAPE" is written when it is requested on card 4.4 of FINDRMS. "IRTAPE", if defined, will contain the arrays calculated in FINDRMS (fig. 12).

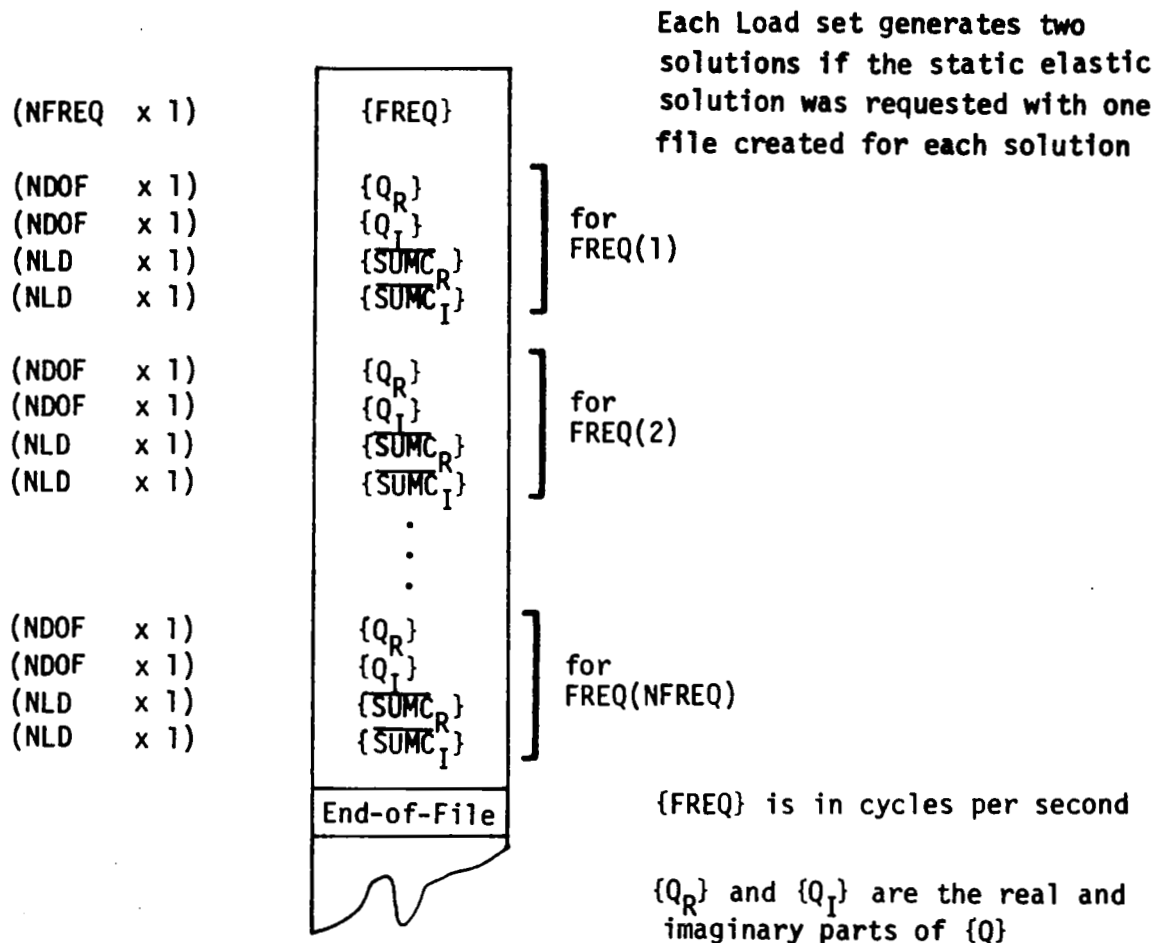

Figure 12.—Contents of the File "IRTAPE"



## "NEWTPE"

The magnetic file "NEWTPE" is written whenever SORTQLS is run. "NEWTPE" will contain alternating matrices of independent and dependent variables to be plotted by another program (see fig. 13).

<u>Size</u>	<u>Matrix</u>
(NFREQ x 1)	{FREQ}
(NFREQ x 1)	{ITEM <sub>1</sub> }
(NFREQ x 1)	{FREQ}
(NFREQ x 1)	{ITEM <sub>2</sub> }
	⋮
(NFREQ x 1)	{FREQ}
(NFREQ x 1)	{ITEM <sub>n</sub> }
	End-of-File

{FREQ} = SCALX \* {FREQ}

{ITEM<sub>i</sub>} = SCALY times the ith item sorted  
by SORTQLS.

Figure 13.—Contents of the File "NEWTPE"

### 6.5.3 PUNCHED CARDS

There is an option in FINDRMS that will cause the program to punch on cards the RMS load values,  $\{\bar{A}\}$ , and number of zero crossings,  $\{N_0\}$ , for each solution. This option is requested by IPUNCH of card 4.3 (sec. 6.3).

The matrices  $\{\bar{A}\}$  and  $\{N_0\}$  will be punched on cards with the format of 7E10.3 with each matrix starting at the beginning of a card (fig. 14).

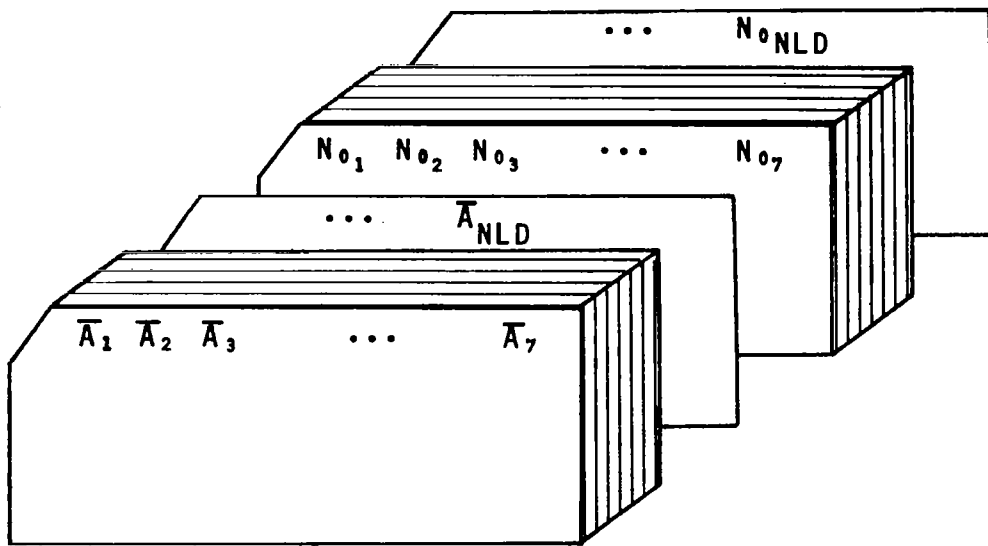

Figure 14.—Format of  $\{\bar{A}\}$  and  $\{N_0\}$  Punched on Cards

## 6.6 RESTRICTIONS

### General:

- Maximum core size allowed for L221 (TEV156) is 200000g.
- All input variables must be within the ranges defined in the card input data (sec. 6.3)

### FINDRMS:

- A maximum of 10 loads may be correlated with any particular load
- Loads per degree of freedom may be printed at a maximum of 10 different frequencies
- A maximum of 10 load sets in one data case

Use of the multiple forcing function option (app. C) results in the following restrictions:

- No gradual penetration
- No feedback
- No loads correlation
- No static-elastic solution
- Generalized coordinates and load frequency response functions may be plotted for only the *first* excitation force
- $\{C_2\}$  and  $\{\bar{C}_2\}$  are null
- Loads per degree of freedom may *not* be printed
- Küssner lift growth function must = 1
- Only the tabular input spectrum can be used

## 6.7 DIAGNOSTICS

All errors detected by L221 (TEV156) will result in the printing of a diagnostic error message. These messages are self-explanatory and are of the following formats:

```
***** FATAL ERROR n
        DIAGNOSED WHILE EXECUTING ROUTINE name
        other lines describing the error
```

```
***** WARNING ERROR n
        DIAGNOSED WHILE EXECUTING ROUTINE name
        other lines describing the error
```

where n is the error number (from 1 to 19), and name is the name of the routine in execution when the error was detected.

All errors are fatal unless they have been diagnosed as warnings. The following list is a brief description of each error.

1. Premature end-of-file was encountered in the card input file.
2. Keyword is not appropriate.
3. Keyword is not recognizable to L221 (TEV156).
4. Tested parameter is not within its specified range or it is in conflict with other options (see the card input data, sec. 6.3).
5. Illegal magnetic file definition.
6. Required core is found to be too large.
7. READTP error (see sec. 6.7.1).
8. WRTETP error (see sec. 6.7.2).
9. PRINTM/PRNTCM error (see sec. 6.7.3).
10. Improper matrix size.
11. FSF error. The returned value i contains the number of file marks remaining to be skipped when an end-of-information was encountered. If n files were to be spaced, then (n-i) files were spaced before the error was detected.
12. [SUMM] matrix was found to be singular when routine CGLESM was called; CGLESM solves  $AX = B$  for X.
13. Extrapolation is required over the tabular input spectra.
14. VARDIM routine errors (see sec. 6.7.4).

15. FETEDIT errors (see sec. 6.7.5).
16. Rudder limiting (RLIMIT) did not converge. This is nonfatal error and execution will continue (see app. B).
17. Unable to sort or plot the RMS load values,  $\bar{A}$ , because they were not contained in file "IPLTPE". This is a nonfatal error and execution will continue.
18. Number of requested plots is incorrect. This is a nonfatal error and execution will continue.
19. Unable to plot 0. on log grid. The current plot will be omitted. This is a nonfatal error and execution will continue.

### 6.7.1 READTP ERROR CODES

Error code	=	0	No errors are detected during reading.
	=	1000+I	A forward space file (FSF) error occurred, where I is the number of file marks remaining to be skipped when an end-of-information was encountered.
	=	2	Number of matrices or files to be skipped, before reading starts, is less than zero.
	=	3	Dimensioned number of rows in the matrix is less than zero.
	=	3000+I	A forward space record (FSR) error occurred, where I is the number of records remaining to be skipped when either an end-of-file or end-of information was encountered.
	=	4	Number of rows in the matrix is greater than the dimensioned row size in the program.
	=	5	Name check failed.
	=	6	Number of rows in the matrix (M) times the number of columns (N) is greater than the buffer size; or $M * N \leq 0$ .
	=	7	End-of-file was read. If it occurs while reading the matrix ID, no information is stored in the user's area. If it occurs while reading the matrix, the ID information will be stored. Note that the records will always be in pairs and an end-of-file should always be encountered with the ID record.

### 6.7.2 WRTETP ERROR CODES

Error code	=	0	No errors are detected during writing.
	=	1000+I	FSF error occurred, where I is the number of file marks remaining to be skipped when an end-of-information was encountered.
	=	2	Number of matrices or files to be skipped, before writing starts, is less than zero.
	=	3	Dimensioned number of rows in the matrix is less than or equal to zero.
	=	3000+I	FSR error occurred, where I is the number of records remaining to be skipped when either an end of file or end-of-information was encountered.
	=	4	Actual number of rows in the matrix is greater than the dimensioned number of rows in the matrix.
	=	6	Number of rows in the matrix (M) times the number of columns (N) is greater than the buffer size.

### 6.7.3 PRINTM/PRNTCM ERROR CODES

Error code	=	0	No error was detected.
	=	3	Number of dimensioned rows is less than or equal to zero.
	=	4	Actual number of rows is greater than the number of dimensioned rows.
	=	6	Actual number of rows times the actual number of columns is less than or equal to zero.

### 6.7.4 VARDIM ROUTINE ERROR CODES

DELETR error code	=	0	Successful.
	=	-2	Name of the array is not contained within the VARDIM library.
INITIR error code	=	0	Successful.
	=	-1	Previous array of the same name was destroyed before the new one was established.

- = 1 Maximum number of catalog entries was exceeded.
  - = 2 One of the array dimensions is zero.
  - = 3 Blank common storage was exceeded.
  - = 4 Routine STARTR was not called beforehand.
- LOCATR error code
- = 0 Successful.
  - = -1 STARTR was not called beforehand.
  - = -2 Name of the array is not contained within the VARDIM library.

### 6.7.5 FETEDIT ERROR CODES

- FETADD error code
- = 0 Successful.
  - = -1 File has been previously defined, no action taken.
  - = 1 An illegal tape number.
  - = 2 Length of either the buffer or array was too small.
  - = 3 Maximum number of files has already been defined (49 allowed).
- FETDEL error code
- = 0 Successful.
  - = -1 File was not defined, no action taken.
  - = 1 An illegal tape number.

## 7.0 SAMPLE PROBLEM

The sample problem shown in this section is a vertical gust analysis of a typical large subsonic jet transport airplane. The theoretical math model consists of two rigid body degrees of freedom (vertical translation and pitch) and six wing elastic normal modes. Unsteady aerodynamics was modeled only for the wing with the Doublet Lattice method. The rigid body aerodynamics representation (rigid body stability derivatives) was obtained from corrected wind tunnel data.

The load equations were generated using the force summation method.



## Sample Problem Card Input Data

SFREQUENCY									1.0	DATA4	2		
STITLE	DOUBLET LATTICE UNSTEADY AERO CHECK CASE								1.1	DATA4	3		
STITLE									1.1	DATA4	4		
STITLE	MULTIPLE FREQUENCY DEPENDENT MATRICES								1.1	DATA4	7		
STITLE									1.1	DATA4	8		
STITLE	THE EQUATIONS OF MOTION WILL BE READ FROM THE MAGNETIC FILE								1.1	DATA4	9		
STITLE	EOMTPE.								1.1	DATA4	10		
STITLE									1.1	DATA4	11		
STITLE	THE LOADS EQUATIONS WILL BE READ FROM THE MAGNETIC FILE								1.1	DATA4	12		
STITLE	LOOTPE.								1.1	DATA4	13		
STITLE									1.1	DATA4	14		
SFINORMS									2.0	DATA4	15		
FREQUENCY	DEPENDENT AERO, 8 DEG. OF FREEDOM, 8 LOADS, 210 FREQUENCIES								3.0	DATA4	16		
	8	710	0	20	0	0			4.1	DATA4	17		
	0	1	0	0	0	1			4.2	DATA4	18		
	1	0	0	1	0	0			4.3	EMPOS	1		
EOMTPE	PLOTPE								4.4	EMPOS	2		
1.	0.		0.		0.		0.		0.	0.	WAGNER DATA4	21	
1.	0.		0.		0.		0.		0.	0.	KUSSNER DATA4	22	
1.0	029.5333		2500.								6.0	DATA4	23
0.0											9.1	DATA4	24
.05	.1	.2	.3	.4	.45	.5					W-1	11.2DATA4	25
.55	.6	.65	.7	.8	.9	1.					W-2	11.2DATA4	26
1.1	1.2	1.3	1.4	1.5	1.6	1.7					W-3	11.2DATA4	27
1.8	1.9	2.0	2.1	2.2	2.4	2.7					W-4	11.2DATA4	28
3.0	3.3	3.6	3.9	4.2	4.5	4.8					W-5	11.2DATA4	29
5.0	5.25	5.5	5.75	6.0	6.25	6.50					W-6	11.2DATA4	30
6.75	7.0	7.25	7.50	7.75	8.0	8.25					W-7	11.2DATA4	31
8.50	8.75	9.0	9.25	9.50	9.75	10.0					W-8	11.2DATA4	32
10.25	10.50	10.75	11.0	11.25	11.50	11.75					W-9	11.2DATA4	33
12.0	12.25	12.50	12.75	13.0	13.25	13.50					W-10	11.2DATA4	34
13.75	14.0	14.25	14.50	14.75	15.0	15.25					W-11	11.2DATA4	35
15.50	15.75	16.0	16.25	16.50	16.75	17.0					W-12	11.2DATA4	36
17.25	17.50	17.75	18.0	18.25	18.50	18.75					W-13	11.2DATA4	37
19.0	19.25	19.50	19.75	20.0	20.25	20.5					W-14	11.2DATA4	38
20.75	21.0	21.25	21.5	21.75	22.0	22.25					W-15	11.2DATA4	39
22.5	22.75	23.0	23.25	23.50	23.75	24.0					W-16	11.2DATA4	40
24.25	24.50	24.75	25.0	25.25	25.50	25.75					W-17	11.2DATA4	41
26.0	26.25	26.50	26.75	27.0	27.25	27.50					W-18	11.2DATA4	42
27.75	28.0	28.25	28.50	28.75	29.0	29.25					W-19	11.2DATA4	43
29.50	29.75	30.00	30.25	30.50	30.75	31.0					W-20	11.2DATA4	44
31.25	31.50	31.75	32.0	32.25	32.50	32.75					W-21	11.2DATA4	45
33.0	33.25	33.50	33.75	34.0	34.25	34.50					W-22	11.2DATA4	46
34.75	35.	35.5	36.	36.5	37.	37.5					W-23	11.2DATA4	47
38.	38.5	39.	39.5	40.	40.5	41.					W-24	11.2DATA4	48
41.5	42.	42.5	43.	43.5	44.	44.5					W-25	11.2DATA4	49
45.	45.5	46.	46.5	47.	47.5	48.					W-26	11.2DATA4	50
48.5	49.	49.5	50.	50.5	51.	51.5					W-27	11.2DATA4	51
52.	52.5	53.	53.5	54.	54.5	55.					W-28	11.2DATA4	52
55.5	56.	56.5	57.	57.5	58.	58.5					W-29	11.2DATA4	53
62.5	69.	75.	82.	88.	94.	99.					W-30	11.2DATA4	54
SEQUATION											12.0	DATA4	55
	1	0	1	1	1	0	0	1			13.1	DATA4	56
BLOAD			8	0				LOOTPE			31.0	DATA4	57
	0	0	1	1	1	0	0	1			33.1	DATA4	58
BEND											49.0	DATA4	59

## Card Input Data (Concluded)

\$SORTQLS			50.0	EMPOS	3
TITLE			51.0	EMPOS	4
TITLE	SAMPLE SORTQLS EXECUTION.		51.0	EMPOS	5
TITLE			51.0	EMPOS	6
SORT	Q	1	59.1	EMPOS	7
3			59.2	EMPOS	8
SORT	LOADS	1	59.1	EMPOS	9
1			59.2	EMPOS	10
\$END SORTQLS EXECUTION					
\$PLOTQLS	USERS NAME / TELEPHONE NO. / MAIL STOP / ORG.		61.0	EMPOS	11
TITLE			62.0	EMPOS	12
TITLE	SAMPLE PLOTQLS EXECUTION.		63.0	EMPOS	13
TITLE			63.0	EMPOS	14
PLOT	Q	1	63.0	EMPOS	15
3			77.1	EMPOS	16
LABEL	EXAMPLE PLOTTING LABEL		77.2	EMPOS	17
PLOT	LOADS	1	72.0	EMPOS	18
1			77.1	EMPOS	19
\$END PLOTQLS EXECUTION					
\$QUIT THE TEV156 PROGRAMMING SYSTEM					
			77.2	EMPOS	20
			79.0	EMPOS	21
			80.0	DATA4	60

### Sample Problem Printed Output

```

*****
*
* PROGRAM L221 VERSION E1
* BEGINNING EXECUTION ON THE BCS 6600.
* DATE OF RUN IS 76/09/29.
* TIME OF RUN IS 21.14.13.
*
*****
($FREQUENCY 1.0 )
($TITLE DOUBLET LATTICE UNSTEADY AERO CHECK CASE 1.1 )
($TITLE 1.1 )
($TITLE MULTIPLE FREQUENCY DEPENDENT MATRICES 1.1 )
($TITLE 1.1 )
($TITLE THE EQUATIONS OF MOTION WILL BE READ FROM THE MAGNETIC FILE. 1.1 )
($TITLE EOMTPE. 1.1 )
($TITLE 1.1 )
($TITLE THE LOADS EQUATIONS WILL BE READ FROM THE MAGNETIC FILE 1.1 )
($TITLE LODTPE. 1.1 )
($TITLE 1.1 )
($FINDRMS 2.0 )

```

FINDRMS, THE PROGRAM TO FIND THE PSD RMS AND NUMBER  
OF ZERO CROSSINGS, IS NOW IN EXECUTION.  
ACCUMULATED CP SECONDS = .9450

THE INITIAL CARD INPUT TO FINDRMS FOLLOWS.

DATA CASE LABEL (CARD SET 3.0).  
(FREQUENCY DEPENDENT AERO, 8 DEG. OF FREEDOM, 8 LOADS, 210 FREQUENCIES )

PROBLEM SIZE (CARD 4.1).  
NUMBER OF DEGREES OF FREEDOM (NDOF) = 8  
NUMBER OF FREQUENCIES (NFREQ) = 210

NUMBER OF K-VALUES (NKVAL) = 20  
FREQUENCY DEPENDENT MATRICES WILL BE READ.  
INTERPOLATION WILL BE USED TO FIND  
THE MATRICES AT THE SOLUTION FREQUENCY.

OPTIONAL CAPABILITIES (CARD 4.2).  
FREQUENCIES (IFREQ) WILL BE READ FROM CARDS IN RAD./SEC.  
SPECTRUM NUMBER (ISPEC) 1 WILL BE USED.  
THE SAME DAMPING FACTOR WILL BE USED FOR EACH FREEDOM (IDAMP .GT.0).  
INTEGRATION WILL BEGIN AT FREQ(1), AND NOT ZERO (INTZRO.EQ.1).

OUTPUT OPTIONS (CARD 4.3).  
THE GEN. COORD. AND LD. TRANSFER FOR EACH FREQUENCY AS WELL AS THE  
FINAL RMS AND NO. OF ZERO CROSSINGS WILL BE PRINTED (IPRINT.EQ.1).  
PRINT ONLY THE FINAL RMS VALUES (IRMSPR.EQ.0).  
THE INPUT MATRICES WILL BE PRINTED (ICKPRT.GT.0).

INPUT TAPE OPTIONS (CARD 4.4).  
THE INPUT MATRICES WILL BE READ FROM EOHPTPE  
THE PLOT DATA WILL BE WRITTEN ON PLOTTPPE

WAGNER FUNCTION COEFFICIENTS (CARD 5.1).  
.1000E+01 0. 0. 0. 0. 0. 0.

KUSSNER FUNCTION COEFFICIENTS (CARD 5.2).  
.1000E+01 0. 0. 0. 0. 0. 0.

THE CORE REQUIRED FOR TABULAR INPUT SPECTRUM(S) IS 0000117746

INPUT CONSTANTS (CARD SET 6).

Z = .1000E+01  
 VEL = .8295E+03  
 L = .2500E+C4

THE STRUCTURAL DAMPING FACTOR (CARD 9.1) USED FOR ALL DEGREES OF FREEDOM = 0.

THE FREQUENCY MATRIX (FREQ) IN CYCLES/SECOND.

.7956E-02	.1592E-01	.3183E-01	.4775E-01	.6366E-01	.7162E-01	.7958E-01
.8754E-01	.9549E-01	.1035E+00	.1114E+00	.1273E+00	.1432E+00	.1592E+00
.1751E+00	.1910E+00	.2069E+00	.2228E+00	.2387E+00	.2546E+00	.2706E+00
.2865E+00	.3024E+00	.3183E+00	.3342E+00	.3501E+00	.3820E+00	.4297E+00
.4775E+00	.5252E+00	.5730E+00	.6207E+00	.6685E+00	.7162E+00	.7639E+00
.7958E+00	.8356E+00	.8754E+00	.9151E+00	.9549E+00	.9947E+00	.1035E+01
.1074E+01	.1114E+01	.1154E+01	.1194E+01	.1233E+01	.1273E+01	.1313E+01
.1353E+01	.1393E+01	.1432E+01	.1472E+01	.1512E+01	.1552E+01	.1592E+01
.1631E+01	.1671E+01	.1711E+01	.1751E+01	.1790E+01	.1830E+01	.1870E+01
.1910E+01	.1950E+01	.1989E+01	.2029E+01	.2069E+01	.2109E+01	.2149E+01
.2188E+01	.2228E+01	.2268E+01	.2308E+01	.2348E+01	.2387E+01	.2427E+01
.2467E+01	.2507E+01	.2546E+01	.2586E+01	.2626E+01	.2666E+01	.2706E+01
.2745E+01	.2785E+01	.2825E+01	.2865E+01	.2905E+01	.2944E+01	.2984E+01
.3024E+01	.3064E+01	.3104E+01	.3143E+01	.3183E+01	.3223E+01	.3263E+01
.3302E+01	.3342E+01	.3382E+01	.3422E+01	.3462E+01	.3501E+01	.3541E+01
.3581E+01	.3621E+01	.3661E+01	.3700E+01	.3740E+01	.3780E+01	.3820E+01
.3860E+01	.3899E+01	.3939E+01	.3979E+01	.4019E+01	.4058E+01	.4098E+01
.4138E+01	.4178E+01	.4218E+01	.4257E+01	.4297E+01	.4337E+01	.4377E+01
.4417E+01	.4456E+01	.4496E+01	.4536E+01	.4576E+01	.4615E+01	.4655E+01
.4695E+01	.4735E+01	.4775E+01	.4814E+01	.4854E+01	.4894E+01	.4934E+01
.4974E+01	.5013E+01	.5053E+01	.5093E+01	.5133E+01	.5173E+01	.5212E+01
.5252E+01	.5292E+01	.5332E+01	.5371E+01	.5411E+01	.5451E+01	.5491E+01
.5531E+01	.5570E+01	.5610E+01	.5650E+01	.5690E+01	.5730E+01	.5770E+01
.5848E+01	.5888E+01	.5928E+01	.5968E+01	.6008E+01	.6048E+01	.6088E+01
.6167E+01	.6207E+01	.6247E+01	.6287E+01	.6327E+01	.6366E+01	.6406E+01
.6485E+01	.6525E+01	.6565E+01	.6605E+01	.6645E+01	.6685E+01	.6725E+01
.6803E+01	.6843E+01	.6883E+01	.6923E+01	.6963E+01	.7003E+01	.7043E+01
.7162E+01	.7202E+01	.7242E+01	.7282E+01	.7321E+01	.7361E+01	.7401E+01
.7480E+01	.7520E+01	.7560E+01	.7600E+01	.7640E+01	.7680E+01	.7720E+01
.7799E+01	.7839E+01	.7878E+01	.7918E+01	.7958E+01	.8037E+01	.8117E+01
.8196E+01	.8236E+01	.8276E+01	.8316E+01	.8356E+01	.8396E+01	.8436E+01
.8476E+01	.8516E+01	.8556E+01	.8596E+01	.8636E+01	.8676E+01	.8716E+01
.8756E+01	.8796E+01	.8836E+01	.8876E+01	.8916E+01	.8956E+01	.8996E+01
.9036E+01	.9076E+01	.9116E+01	.9156E+01	.9196E+01	.9236E+01	.9276E+01
.9316E+01	.9356E+01	.9396E+01	.9436E+01	.9476E+01	.9516E+01	.9556E+01
.9596E+01	.9636E+01	.9676E+01	.9716E+01	.9756E+01	.9796E+01	.9836E+01
.9876E+01	.9916E+01	.9956E+01	.9996E+01	.1000E+02	.1000E+02	.1000E+02

1 EQUATION  
 ( 1 0 1 1 1 0 0 1 12.0 )  
 ( 1 0 1 1 1 0 0 1 13.1 )

CHOOSE MATRICES TO BE READ FOR GEN. COORD. (CARD SET 13) BY CODE OF 0 OR 1.  
 MATRICES ASSUMED NULL AND NOT READ IF CODE = 0.

M1 M2 M3 M4 M5 M6 S1 S2 S3 S4 S5 S6  
 1 0 1 1 1 0 0 0 0 0 0 0

C2 C3 FLL PHIT  
 0 1 0 0

THE CORE REQUIRED TO FIND THE GEN. COORD. IS 0000121543

MATRIX -----

LABEL M1

SIZE 8 ROWS AND 8 COLUMNS -----

COLUMN	1	2	3	4	5	6	7	8
ROW 1	0.	0.	0.	0.	0.	0.	0.	0.
ROW 2	0.	0.	0.	0.	0.	0.	0.	0.
ROW 3	0.	0.	0.	0.	0.	0.	0.	0.
ROW 4	0.	0.	0.	.9483E+03	0.	0.	0.	0.
ROW 5	0.	0.	0.	0.	.4589E+04	0.	0.	0.
ROW 6	0.	0.	0.	0.	0.	.3413E+04	0.	0.
ROW 7	0.	0.	0.	0.	0.	0.	.6143E+05	0.
ROW 8	0.	0.	0.	0.	0.	0.	0.	.9772E+04

MATRIX -----  
 LABEL M3  
 SIZE 8 ROWS AND 8 COLUMNS  
 -----

COLUMN	1	2	3	4	5	6	7	8
ROW 1	.9788E+03	0.	0.	0.	0.	0.	0.	0.
ROW 2	0.	.1729E+09	0.	0.	0.	0.	0.	0.
ROW 3	0.	0.	.2396E+02	0.	0.	0.	0.	0.
ROW 4	0.	0.	0.	.2517E+02	0.	0.	0.	0.
ROW 5	0.	0.	0.	0.	.9367E+01	0.	0.	0.
ROW 6	0.	0.	0.	0.	0.	.8987E+02	0.	0.
ROW 7	0.	0.	0.	0.	0.	0.	.6493E+01	0.
ROW 8	0.	0.	0.	0.	0.	0.	0.	.8975E+01

MATRIX -----  
 LABEL FREQM  
 SIZE 1 ROWS AND 20 COLUMNS  
 -----

COLUMN	1	2	3	4	5	6	7	8	9	10
	.4886E-01	.8000E+00	.1698E+01	.3594E+01	.6241E+01	.7988E+01	.1098E+02	.1348E+02	.1599E+02	.1897E+02
	.2197E+02	.2596E+02	.3195E+02	.3894E+02	.4294E+02	.4593E+02	.5192E+02	.6890E+02	.7489E+02	.9985E+02

THE FREQUENCY DEPENDENT FREQUENCY MATRIX (FREQM) IN CYCLES/SECOND.

.7776E-02	.1273E+00	.2702E+00	.5720E+00	.9933E+00	.1271E+01	.1748E+01
.2146E+01	.2544E+01	.3019E+01	.3496E+01	.4132E+01	.5085E+01	.6198E+01
.6833E+01	.7310E+01	.8264E+01	.1097E+02	.1192E+02	.1589E+02	

Note: The equations of motion input matrices ( $M_4$ ,  $M_5$ , and  $C_3$ ) have been omitted from this document.

\*\*\*\*\*  
 FREQUENCY DEPENDENT AERO, 8 DEG. OF FREEDOM, 8 LOADS, 210 FREQUENCIES

Note: The frequency-dependent equations of motion input matrices ( $M_4$ ,  $M_5$ , and  $C_3$ ) have been omitted from this document.

FREQ( 1) = .7558E-02 CYCLES/SEC. ( .5000E-01 RAD./SEC.)

	RESPONSE	MAGNITUDE	PHASE ANGLE
1	.10713E+02	.58339E+02	.59315E+02
2	-.91767E-03	-.29277E-04	.91813E-03
3	.26366E-02	-.16884E-01	.17089E-01
4	.15313E-03	-.70764E-03	.72402E-03
5	.88676E-04	-.64332E-03	.64940E-03
6	.13561E-04	-.28584E-03	.28616E-03
7	-.89028E-04	-.34187E-03	.35327E-03
8	-.27395E-04	.10856E-03	.11196E-03

-----  
 FREQ( 2) = .1592E-01 CYCLES/SEC. ( .1000E+00 RAD./SEC.)

	RESPONSE	MAGNITUDE	PHASE ANGLE
1	.17351E+01	.29034E+02	.29086E+02
2	-.92075E-03	.32373E-04	.92132E-03
3	.39171E-02	-.34158E-01	.34422E-01
4	.21431E-03	-.14381E-02	.14540E-02
5	.13457E-03	-.13025E-02	.13094E-02
6	.33663E-04	-.57564E-03	.57663E-03
7	.11663E-03	-.69594E-03	.70565E-03
8	-.35884E-04	.22082E-03	.22372E-03



Note: Frequencies 3 through 208, including the associated frequency-dependent equations of motion input matrices ( $M_4$ ,  $M_5$ , and  $C_3$ ), have been omitted from this document.

FREQ(209) = .1496E+02 CYCLES/SEC. ( .9400E+02 RAD./SEC.)

	RESPONSE	MAGNITUDE	PHASE ANGLE	
1	.74946E-03	.27962E-03	.79993E-03	.35710E+00
2	.49438E-06	.16401E-06	.52088E-06	.32032E+00
3	.34458E-02	.11457E-02	.36313E-02	.32100E+00
4	.24296E-02	.22180E-02	.32897E-02	.73990E+00
5	.57369E-03	.19767E-04	.57403E-03	.34442E-01
6	.22801E-03	-.18003E-03	.29052E-03	.56148E+01
7	.63770E-02	.39910E-02	.75229E-02	.55920E+00
8	-.32289E-02	.93835E-03	.33625E-02	.28588E+01

FREQ(210) = .1576E+02 CYCLES/SEC. ( .9900E+02 RAD./SEC.)

	RESPONSE	MAGNITUDE	PHASE ANGLE	
1	.68112E-03	.26099E-03	.72941E-03	.36592E+00
2	.45448E-06	.14746E-06	.47781E-06	.31375E+00
3	.31473E-02	.11022E-02	.33347E-02	.33685E+00
4	.22805E-02	.20300E-02	.30531E-02	.72736E+00
5	.56877E-03	.47941E-04	.57078E-03	.84090E-01
6	.19282E-03	-.12941E-03	.23222E-03	.56921E+01
7	.57701E-02	.35661E-02	.67832E-02	.55357E+00
8	-.27317E-02	.93460E-03	.28871E-02	.28119E+01

(SLOAD            8   0            LODTPE                            31.0    )

LODTAPE WHICH CONTAINS THE LOAD EQUATIONS IS DEFINED AS LODTPE  
THE FILE DEFINED BY INTAPE (EOMTPE ) WILL BE REPLACED BY LODTAPE.

THE NUMBER OF LOAC EQUATIONS IN SET    1 IS    8

(    0    0    1    1    1    0    0    1                            33.1    )

CHOOSE MATRICES TO BE READ FOR LOADS SOLUTION (CARD SET 33),  
MATRICES ASSUMED NULL AND NOT READ IF CODE ≠ 0.

MB1 MB2 MB3 MB4 MB5 MB6    SB1 SB2 SB3 SB4 SB5 SB6  
0 0 1 1 1 0    0 0 0 0 0 0

C28 C38 PH18  
0 1 0

CORE REQUIRED TO FIND LOADS AND RMS VALUES IS 0000121601

MATRIX -----									
LABEL MB3									
SIZE 8 ROWS AND 8 COLUMNS -----									
COLUMN	1	2	3	4	5	6	7	8	
ROW 1	.2020E+02	.8198E+04	.1247E+02	.7925E+01	.4694E+01	.2602E+01	-.6585E+00	-.1545E+01	
ROW 2	.1638E+03	.3571E+05	.4642E+02	-.5952E+01	-.1283E+02	-.2279E+01	.1503E+01	.2726E+01	
ROW 3	.4709E+03	.9257E+04	.3624E+02	-.9530E+01	-.1663E+02	.5472E+02	.9569E+01	-.1093E+02	
ROW 4	.2590E-02	.1456E+01	.2590E-02	.2590E-02	.2590E-02	.2590E-02	.2590E-02	.2590E-02	.2590E-02
ROW 5	.2590E-02	.8817E+00	.1182E-02	.4881E-03	-.8700E-04	-.2612E-03	-.5400E-03	-.1916E-03	
ROW 6	.2590E-02	.1741E+00	.6979E-04	-.3017E-04	-.2917E-03	.6502E-03	.3199E-03	-.2806E-03	
ROW 7	.2590E-02	-.4028E+00	-.1499E-03	.5830E-04	.7573E-04	-.2852E-03	-.4320E-04	.4949E-04	
ROW 8	.2590E-02	0.	0.	0.	0.	0.	0.	0.	

Note: The load equations input matrices ( $\bar{M}_4$ ,  $\bar{M}_5$ , and  $\bar{C}_3$ ) have been omitted from this document.

-----  
 FREQUENCY DEPENDENT AERO, 8 DEG. CF FREECCP, 8 LOADS, 210 FREQUENCIES

RESULTS FOR LOAD SET NO. 1

Note: The frequency-dependent load equations input matrices ( $\bar{M}_4$ ,  $\bar{M}_5$ , and  $\bar{C}_3$ ) have been omitted from this document.

FREQ( 1) = .7558E-02 CYCLES/SEC. ( .5000E-01 RAD./SEC.)

VALUE OF INPUT SPECTRUM = .81993E+03 0. (LEN./SEC.)\*\*2/(RAD.\*LEN.)

	LOADS		MAGNITUDE	PHASE ANGLE (RAD.)	OUTPUT SPECTRUM LOAD/(RAD./LEN.)
1	-.32099E+01	.14992E+02	.15332E+02	.17817E+01	.19274E+06
2	-.10633E+02	.31283E+02	.33041E+02	.18985E+01	.89514E+06
3	-.18671E+02	.37249E+02	.41667E+02	.20354E+01	.14235E+07
4	-.66051E-04	-.37756E-03	.38329E-03	.45392E+01	.12046E-03
5	-.67357E-04	-.37767E-03	.38363E-03	.45359E+01	.12067E-03
6	-.68973E-04	-.37777E-03	.38401E-03	.45318E+01	.12091E-03
7	-.70295E-04	-.37782E-03	.38430E-03	.45284E+01	.12109E-03
8	-.69372E-04	-.37778E-03	.38410E-03	.45308E+01	.12097E-03

-----  
 FREQ( 2) = .1592E-01 CYCLES/SEC. ( .1000E+00 RAD./SEC.)

VALUE OF INPUT SPECTRUM = .86555E+03 0. (LEN./SEC.)\*\*2/(RAD.\*LEN.)

	LOADS		MAGNITUDE	PHASE ANGLE (RAD.)	OUTPUT SPECTRUM LOAD/(RAD./LEN.)
1	-.43179E+01	.30451E+02	.30756E+02	.17117E+01	.81873E+06
2	-.12956E+02	.63927E+02	.65226E+02	.17708E+01	.36625E+07
3	-.21940E+02	.76721E+02	.79796E+02	.18493E+01	.55113E+07
4	-.31653E-04	-.75153E-03	.75220E-03	.46703E+01	.48973E-03
5	-.36871E-04	-.75192E-03	.75283E-03	.46634E+01	.49055E-03
6	-.43343E-04	-.75207E-03	.75332E-03	.46548E+01	.49120E-03
7	-.48646E-04	-.75197E-03	.75354E-03	.46478E+01	.49148E-03
8	-.44943E-04	-.75204E-03	.75339E-03	.46527E+01	.49128E-03

Note: Frequencies 3 through 208, including the associated frequency-dependent load equations input matrices ( $\bar{M}_4$ ,  $\bar{M}_5$ , and  $\bar{C}_3$ ), have been omitted from this document.

FREQ(209) = .1456E+02 CYCLES/SEC. ( .9400E+02 RAD./SEC.)

VALUE OF INPUT SPECTRUM = .10676E+00 0. (LEN./SEC.)\*\*2/(RAD.\*LEN.)

	LOADS		MAGNITUDE	PHASE ANGLE (RAD.)	OUTPUT SPECTRUM LOAD/(RAD./LEN.)
1	.89468E+02	-.32225E+02	.95095E+02	.59375E+01	.96541E+03
2	-.15716E+03	-.18815E+03	.24515E+03	.40165E+01	.64161E+04
3	-.49232E+02	.29854E+03	.30258E+03	.17342E+01	.97738E+04
4	-.24838E+00	-.19465E+00	.31557E+00	.38063E+01	.10631E-01
5	-.41540E-01	-.89769E-02	.42499E-01	.33544E+01	.19282E-03
6	-.45255E-01	-.14637E-01	.47563E-01	.34544E+01	.24151E-03
7	-.80431E-02	-.47944E-02	.93637E-02	.36791E+01	.93603E-05
8	-.17153E-01	-.63998E-02	.18308E-01	.34987E+01	.35784E-04

FREQ(210) = .1576E+02 CYCLES/SEC. ( .9900E+02 RAD./SEC.)

VALUE OF INPUT SPECTRUM = .97923E-01 0. (LEN./SEC.)\*\*2/(RAD.\*LEN.)

	LOADS		MAGNITUDE	PHASE ANGLE (RAD.)	OUTPUT SPECTRUM LOAD/(RAD./LEN.)
1	.90098E+02	-.31375E+02	.95405E+02	.59481E+01	.89130E+03
2	-.16948E+03	-.17830E+03	.24599E+03	.39523E+01	.59256E+04
3	-.12585E+02	.30841E+03	.30867E+03	.16116E+01	.93297E+04
4	-.25804E+00	-.20044E+00	.32674E+00	.38020E+01	.10454E-01
5	-.42198E-01	-.10040E-01	.43376E-01	.33752E+01	.18424E-03
6	-.44753E-01	-.14681E-01	.47100E-01	.34586E+01	.21723E-03
7	-.82904E-02	-.49245E-02	.96427E-02	.36776E+01	.91050E-05
8	-.17292E-01	-.66257E-02	.18518E-01	.35075E+01	.33578E-04

-----  
FREQUENCY DEPENDENT AERO, 8 DEG. CF FREEDOM, 8 LOADS, 210 FREQUENCIES

RESULTS FOR LOAD SET NO. 1

	RMS	ZERO CROSSINGS (PER LENGTH)
1	.53591E+03	.10644E-02
2	.15512E+04	.11629E-02
3	.16769E+04	.22369E-02
4	.12932E+00	.65833E-02
5	.44672E-01	.33815E-02
6	.17458E-01	.63952E-02
7	.12299E-01	.18940E-02
8	.12010E-01	.25276E-02

(SEND

49.0 )

FINDRMS IS FINISHED.  
ACCUMULATED CP SECONDS = 23.7090

(ISORTQLS

50.0 )

SORTQLS, THE PROGRAM TO SORT PLOT VECTORS FROM FINDRMS IS NOW IN EXECUTION.

ACCUM. CP SEC. = 23.7090

```

(TITLE                               51.0 )
(TITLE          SAMPLE SORTQLS EXECUTION. 51.0 )
(TITLE                               51.0 )
(SORT          0          1          59.1 )
THE NUMBER OF ITEMS TO BE SORTED (NSORT) = 1
THE NUMBERS THAT ARE TO BE SORTED.
3

```

CORE REQUIRED TO SORT IS 0000045602

SORT GEN. COORD 3 FROM STANDARD SOLUTION OF LOAD SET 1

```

(SORT          LOADS          1          59.1 )
THE NUMBER OF ITEMS TO BE SORTED (NSORT) = 1
THE NUMBERS THAT ARE TO BE SORTED.
1

```

CORE REQUIRED TO SORT IS 0000045602

SORT LOAD TRANS 1 FROM STANDARD SOLUTION OF LOAD SET 1

(SEND SORTQLS EXECUTION 61.0 )

SORTQLS IS FINISHED.

ACCUM. CP SEC. = 25.3960

(SPLOTQLS USERS NAME / TELEPHONE NO. / MAIL STOP / ORG.

62.0 )

PLOTQLS, THE PROGRAM USED TO PLOT DATA VECTORS  
IS NOW IN EXECUTION.  
ACCUMULATED CP SECCNDS = 25.3600

(TITLE SAMPLE PLOTQLS EXECUTION. 63.0 )  
(TITLE 63.0 )  
(TITLE 63.0 )  
(PLOT 0 1 77.1 )  
THE NUMBER OF ITEMS (NPLOT) TO BE PLOTTED = 1  
THE NUMBERS THAT ARE TO BE PLOTTED.  
3

THE CORE REQUIRED TO PLOT IS 0000070340

PLOT GEN. COORD 3 FROM STANDARD SOLUTION OF LOAD SET 1

(LABEL EXAMPLE PLOTTING LABEL 72.0 )  
(PLOT LOADS 1 77.1 )  
THE NUMBER OF ITEMS (NPLOT) TO BE PLOTTED = 1  
THE NUMBERS THAT ARE TO BE PLOTTED.  
1

THE CORE REQUIRED TO PLOT IS 0000070340

PLOT LOAD TRANS 1 FROM STANDARD SOLUTION OF LOAD SET 1

(SEND PLOTQLS EXECUTION 79.0 )

PLOTQLS IS FINISHED.  
ACCUMULATED CP SECCNDS = 27.9190



(QUIT THE TEV156 PROGRAMMING SYSTEM

80.0 )

PLOTQLS IS FINISHED.  
ACCUMULATED CP SECONDS = 27.9300

GEN. COORD. NO. 3. LOAD SET 1

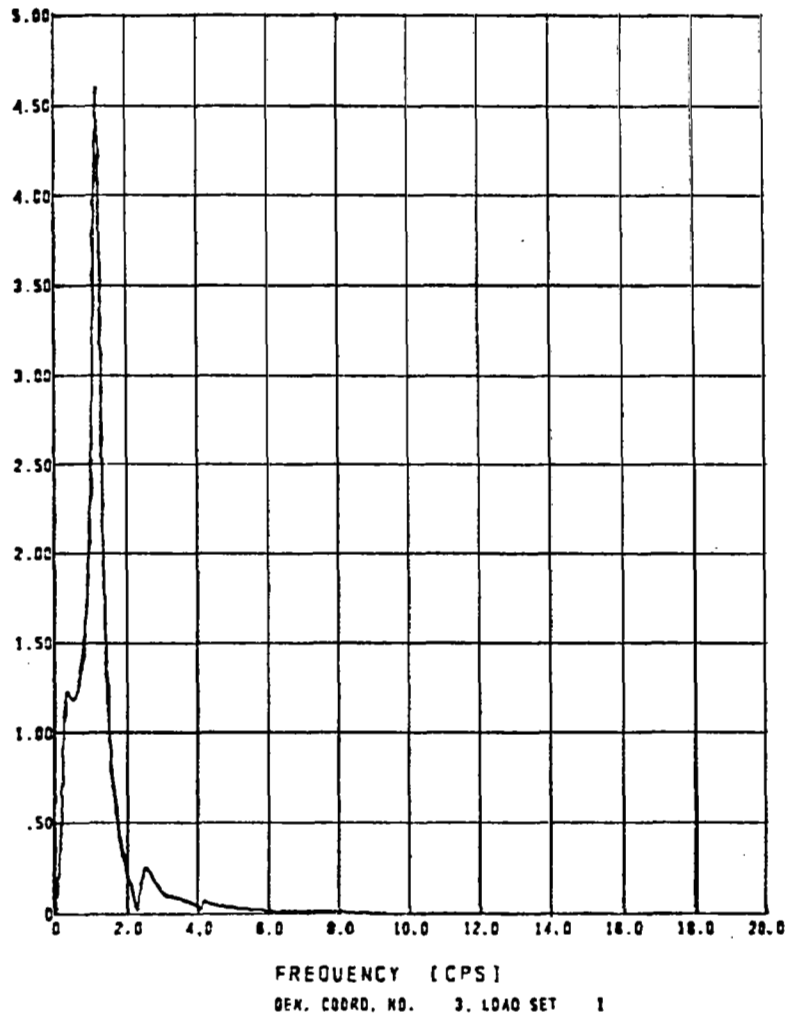

LOAD TRANS. NO. 1. LOAD SET 1

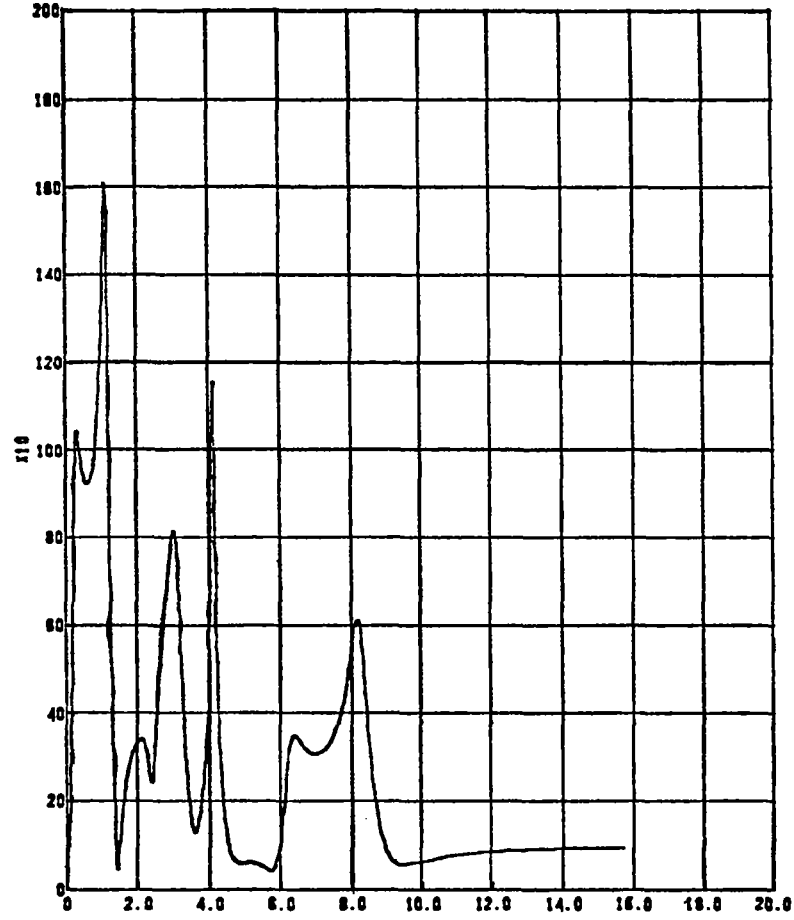

FREQUENCY [CPS]

LOAD TRANS. NO. 1. LOAD SET 1

EXAMPLE PLOTTING LABEL

## APPENDIX A

### FREQUENCY ARRAY FORMULATION

FINDRMS can automatically prepare five different distributions of frequencies

$$\text{FREQ}_i; i = 1, \text{NFREQ}$$

over which the power spectral density (PSD) solution will be found. The option ISPEC (card 4.2) chooses one of the five distributions shown below.

Given: Initial frequency,  $\text{FREQ}(1)$  or  $\omega_1$  (card 11.3)  
Frequency increment, DELTAF or  $\Delta\omega$  (card 11.3)  
Number of frequencies, NFREQ or  $n$  (card 4.1)

If ISPEC=1

$$\begin{aligned}\omega_j &= \omega_1 + j\Delta\omega && \text{where } j=1, \dots, (n-5) \\ \omega_{n-4} &= \omega_{n-5} + 200\Delta\omega \\ \omega_{n-3} &= \omega_{n-4} + 200\Delta\omega \\ \omega_{n-2} &= \omega_{n-3} + 1000\Delta\omega \\ \omega_{n-1} &= \omega_{n-2} + 2000\Delta\omega \\ \omega_n &= \omega_{n-1} + 3000\Delta\omega\end{aligned}$$

If ISPEC=2

$$\begin{aligned}\omega_j &= \omega_1 + j\Delta\omega && \text{where } j=1, \dots, k, \text{ and } k = \frac{2}{3}(n-5), \text{ truncated} \\ \omega_j &= \omega_{j-1} + 2\Delta\omega && \text{where } j=k+1, \dots, (n-5) \\ \omega_{n-4} &= \omega_{n-5} + 200\Delta\omega \\ \omega_{n-3} &= \omega_{n-4} + 200\Delta\omega \\ \omega_{n-2} &= \omega_{n-3} + 1000\Delta\omega \\ \omega_{n-1} &= \omega_{n-2} + 2000\Delta\omega \\ \omega_n &= \omega_{n-1} + 3000\Delta\omega\end{aligned}$$

If ISPEC=3

$$\omega_j = \omega_1 + j\Delta\omega$$

$$\omega_j = \omega_{j-1} + 2\Delta\omega$$

$$\omega_j = \omega_{j-1} + 4\Delta\omega$$

$$\omega_{n-4} = \omega_{n-5} + 200\Delta\omega$$

$$\omega_{n-3} = \omega_{n-4} + 200\Delta\omega$$

$$\omega_{n-2} = \omega_{n-3} + 1000\Delta\omega$$

$$\omega_{n-1} = \omega_{n-2} + 2000\Delta\omega$$

$$\omega_n = \omega_{n-1} + 3000\Delta\omega$$

where  $j=1, \dots, k$ , and  $k=\frac{1}{2}(n-5)$ , truncated

where  $j=k+1, \dots, k_2$ , and  $k_2=\frac{3}{4}(n-5)$ , truncated

where  $j=k_2+1, \dots, (n-5)$

If ISPEC=4

$$\omega_j = \omega_1 + j\Delta\omega$$

$$\omega_j = \omega_{j-1} + 2\Delta\omega$$

$$\omega_j = \omega_{j-1} + 4\Delta\omega$$

$$\omega_j = \omega_{j-1} + 6\Delta\omega$$

$$\omega_{n-4} = \omega_{n-5} + 200\Delta\omega$$

$$\omega_{n-3} = \omega_{n-4} + 200\Delta\omega$$

$$\omega_{n-2} = \omega_{n-3} + 1000\Delta\omega$$

$$\omega_{n-1} = \omega_{n-2} + 2000\Delta\omega$$

$$\omega_n = \omega_{n-1} + 3000\Delta\omega$$

where  $j=1, \dots, k$ , and  $k=\frac{1}{2}(n-15)$ , truncated

where  $j=k+1, \dots, k_2$ , and  $k_2=\frac{3}{4}(n-15)$ , truncated

where  $j=k_2+1, \dots, n-15$

where  $j=n-14, \dots, n-5$

If IFSPEC=5

$$\omega_j = \omega_1 + .5\Delta\omega$$

where  $j=1, \dots, 6$

$$\omega_j = \omega_{j-1} + \Delta\omega$$

where  $j=7, \dots, k$ , and  $k=\frac{1}{2}(n-15)$

$$\omega_j = \omega_{j-1} + 2\Delta\omega$$

where  $J=k, \dots, k_2$ , and  $k_2=\frac{3}{2}(k)$

$$\omega_j = \omega_{j-1} + 4\Delta\omega$$

where  $j=k_2, \dots, k_3$ , and  $k_3=2k$

$$\omega_j = \omega_{j-1} + 6\Delta\omega$$

where  $j=k_3, \dots, k_4$ , and  $k_4=(n-4)$

$$\omega_{n-4} = \omega_{n-5} + 200\Delta\omega$$

$$\omega_{n-3} = \omega_{n-4} + 200\Delta\omega$$

$$\omega_{n-2} = \omega_{n-3} + 1000\Delta\omega$$

$$\omega_{n-1} = \omega_{n-2} + 2000\Delta\omega$$

$$\omega_n = \omega_{n-1} + 3000\Delta\omega$$

## APPENDIX B

### SPECIAL FEEDBACK

The special feedback option is geared to a particular problem—the physical limit on the deflection angle of a rudder used in a feedback damping system. The rudder-limiting option, when activated, inspects the magnitude of the rudder angle. When the angle is less than the limit angle (RLIMIT,  $\delta_{Rlim}$ , radians), the program functions in the normal fashion. At any frequency where the angle called for is greater than the limit, the program decreases the yaw damper gain to match the rudder's physical limit by using the ratio of  $\delta_{Rlim}/\delta_R$ . The phase angle remains the same as that originally called for.

The option has been used to plot curves similar to curve A in the following sketch.

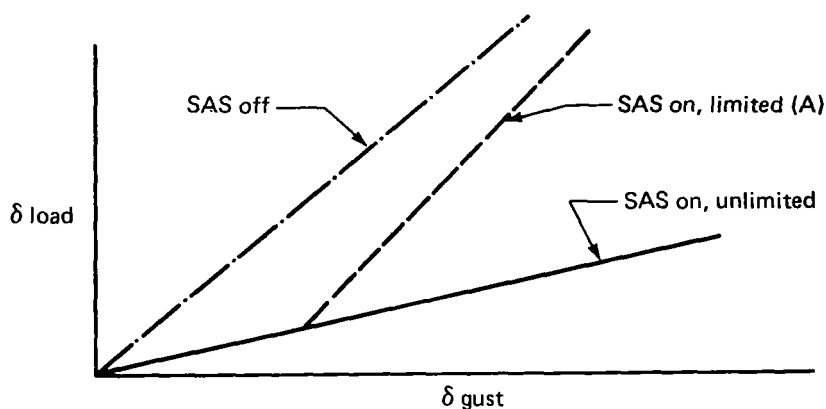

Note: Stability augmentation system (SAS)

This information allows the engineer to determine the effect of rudder limiting on load exceedances.

The special feedback option results in the following three steps in the program's code.

1. For each frequency, the FINDRMS subroutine SOLVEQ calculates  $\{Q\}$  in the same manner used for the standard feedback option.

$$[\text{SUMM}] = [M_1] + i[g_{SD}^{\circ}][\overset{\circ}{M}_1] + s[M_2] + \dots + s^2 g(s)[M_6]$$

$$+ \text{Fydamp} \left[ [S_1] + s[S_2] + \dots + s^2 g(s)[S_6] \right]$$

$$\{\text{SUMC}\} = -z \left\{ f(s)\{C_3\} + \{C_2\} \right\}$$

$$\text{Fydamp} = \frac{G(P_1s^2 + U_1s + R_1)(P_2s^2 + U_2s + R_2)(P_3s^2 + U_3s + R_3)(T_1s + 1)}{(P_4s^2 + U_4s + R_4)\dots(P_7s^2 + U_7s + R_7)(T_2s + 1)(T_3s + 1)\dots(T_7s + 1)}$$

2. Now SOLVEQ solves for the rudder angle,  $\delta_R$

$$\delta_R = \left| \sum_{i=1}^{\text{NDOF}} \text{Fydamp} (Q_i(CS2is^2 + CS1is + CS0i)) \right|$$

where  $|a|$  is the absolute value of the complex number  $a$ .

3. Next, the program checks  $\delta_R$  against  $\delta_{R_{lim}}$ . If  $\delta_R \leq \delta_{R_{lim}}$ , the solution is accepted. If not, the feedback transfer function is factored (multiplied by  $\delta_{R_{lim}}/\delta_R$ ) and steps 1 and 2 are repeated until  $\delta_R$  falls within the limits of

$$\delta_{R_{lim}} \pm 0.01\delta_{R_{lim}}$$

However, if in five iterations  $\delta_R$  does not converge to  $\delta_{R_{lim}}$ , the following message is printed and the current solution is accepted.

```
***** WARNING ERROR 16
RUDDER LIMITING DID NOT CONVERGE ON RLIMIT( )
FOR FREQ( ) =
AFTER 5 TRIES AMAG =
RUN WILL PROCEED WITHOUT CONVERGING.
```



## APPENDIX C

### MULTIPLE EXCITATION FORCING FUNCTIONS

The analytical steps followed in section 5.0 describe the operation of FINDRMS for a system being excited by a single excitation source. FINDRMS can also be used to compute the RMS response levels and number of zero crossings for systems responding to multiple excitations. The multiple excitation mode, however, does not include all of the capabilities available during the execution of the single excitation mode. The following options are *excluded* when using multiple excitations:

- Feedback
- Gradual penetration
- Built-in input spectrum
- Küssner lift growth function ( $f(s)$  must = 1.)
- Load correlation
- Printing of loads per degrees of freedom
- Static-elastic solution

In addition:

- Frequency responses and load transfer functions can be plotted for only the first excitation force.
- $\{C_2\}$  and  $\{\bar{C}_2\}$  are null.

The FINDRMS analytical steps for multiple excitations are:

1. Read card input of options and constants
2. Read card or magnetic file input of equations of motion  $[M_1]$ ,  $[M_2]$ , ...,  $[M_6]$ , plus the excitation forces  $[C_3]$ .

Note:  $[C_3]$  is a rectangular matrix with NDOF (number of degrees of freedom) rows and NFORC (number of excitation force) columns. The  $C_{3ij}$  element is the excitation scalar for the  $i$ th mode responding to the  $j$ th force.

3. For each of the NFREQ frequencies, solve for  $[Q]$  the generalized coordinate frequency response and save  $[Q]$  on "SCRATCH" file. The generalized coordinates are found by solving the following equations.

$$[\text{SUMM}][Q] = [\text{SUMC}]$$

where:

$$[\text{SUMM}] = [M_1] + i[g_{SD}^{\circ}][M_1^{\circ}] + s[M_2] + s^2[M_3] \\ + g(s)[M_4] + sg(s)[M_5] + s^2g(s)[M_6]$$

where:

$$s = i\omega = \text{Laplace transform variable}$$

$$g(s) = \text{Laplace transform of the Wagner function}$$

$$= a_1 - \frac{b_1 s}{s + \alpha_1} - \frac{c_1 s}{s + \beta_1} - \frac{d_1 s}{s + \gamma_1}$$

$$[\text{SUMC}] = -z[C_3]$$

Note: Optionally, the input matrices  $[M_4]$ ,  $[M_5]$ ,  $[M_6]$ , and  $[C_3]$  or  $[\tilde{\phi}]$  are frequency dependent. Interpolation is required to define those matrices at each frequency,  $\omega$ , before calculating  $[\text{SUMM}]$ ,  $[\text{SUMC}]$ , and  $[Q]$ .

Optionally, the user can delete specified degrees of freedom. This is accomplished by zeroing out the appropriate degrees of freedom in the  $[\text{SUMM}]$  and  $[\text{SUMC}]$  summation matrices.

4. Read card or magnetic file input of load equations  $[\bar{M}_1]$ ,  $[\bar{M}_2]$ , ...,  $[\bar{M}_6]$ , and  $[\bar{C}_3]$ ; where  $[\bar{C}_3]$  is NLD (number of load equations) by NFORC (number of excitation forces).
5. For each frequency, read  $[Q]$  (from step 3), calculate  $[\overline{\text{SUMC}}]$ , calculate the input spectrum  $[\phi(\Omega)]$ , calculate the output spectrum SPEC, optionally write data on files "IPLTPE" and "IRTAPE", optionally print  $[\text{SUMC}]$ , and keep a running integration over the frequencies of  $\{\bar{A}\}$  and  $\{N_0\}$ .

$$[\overline{\text{SUMC}}] = [\overline{\text{SUMM}}][Q] + |z|[\bar{C}_3]$$

where:

$$[\overline{\text{SUMM}}] = [\bar{M}_1] + s[\bar{M}_2] + s^2[\bar{M}_3] + g(s)[\bar{M}_4] + sg(s)[\bar{M}_5] + s^2g(s)[\bar{M}_6]$$

The integration for  $\{\bar{A}\}$  and  $\{N_0\}$  at one load,  $\ell$ , is shown as:

$$\bar{A}_\ell = \sqrt{\sum_{i=1}^{NFREQ} \left( \frac{SPEC_{\ell i} + SPEC_{\ell i-1}}{2} \right) (\Omega_i - \Omega_{i-1})}$$

$$N_{O\ell} = \left( \frac{1}{2\pi A_\ell} \right) \sqrt{\sum_{i=1}^{NFREQ} \left( \frac{SPEC_{\ell i} \Omega_i^2 + SPEC_{\ell i-1} \Omega_{i-1}^2}{2} \right) (\Omega_i - \Omega_{i-1})}$$

where  $SPEC_{\ell i}$  is the output spectrum calculated for load  $\ell$  at frequency  $i$  and is found by:

$$SPEC_{\ell i} = \sum_{k=1}^{NFORC} SUMC_{k,\ell}(\Omega_i) SUMC_{k,\ell}^*(\Omega_i) \phi_{k,k}(\Omega_i) + 2\Re \left( \sum_{k=1}^{NFORC} \sum_{j=k+1}^{NFORC} SUMC_{k,\ell}(\Omega_i) SUMC_{j,\ell}^*(\Omega_i) \phi_{k,j}(\Omega_i) \right)$$

where  $(-)^*$  denotes complex conjugate of  $(-)$ ,  $\phi_{k,j}$  is the input spectrum, and  $\Re (-)$  denotes the real part of  $(-)$ . This equation is derived from the more general form:

$$SPEC_{\ell i} = \sum_{k=1}^{NFORC} \sum_{j=1}^{NFORC} SUMC_{k,\ell}(\Omega_i) SUMC_{j,\ell}(\Omega_i) \phi_{k,j}(\Omega_i)$$

by utilizing the Hermitian property of  $\phi_{k,j}$ .

Note: Optionally, the input matrices  $[\bar{M}_4]$ ,  $[\bar{M}_5]$ ,  $[\bar{M}_6]$ ,  $[\bar{C}_3]$  or  $[\bar{\phi}]$  are frequency dependent ( $NKVAL > 1$ ). Interpolation is required to define those matrices at each frequency,  $\omega$ , before calculating  $[\overline{SUMM}]$ ,  $\{\overline{SUMC}\}$ , etc.

Optionally, the user can delete specified degrees of freedom. This is accomplished by the zeroing of the appropriate degrees of freedom in the summation matrix,  $[\overline{SUMM}]$ .

6. Print  $[\bar{A}]$  and  $\{N_0\}$  and optionally punch them out on cards.
7. For additional sets of load equations, repeat steps 4 through 6.

## REFERENCES

1. Miller, R. D.; Knoll, R. I.; and Clemmons, R. E.: Dynamic Loads Analysis System (DYLOFLEX) Summary. NASA CR-2846-1, 1979.
2. Miller, R. D.; Richard, M.; and Rogers, J. T.: Feasibility of Implementing Unsteady Aerodynamics Into the FLEXSTAB Computer Program System. NASA CR-132530, 1974.
3. Fung, Y. C.: An Introduction to the Theory of Aeroelasticity. Dover Publications, Inc., 1969.
4. Bisplinghoff, R. L.; Ashley, H.; and Halfman, R. L.: Aeroelasticity. Addison-Wesley Publishing Company, Inc., 1955.

1. Report No. <b>NASA CR-2857</b>	2. Government Accession No.	3. Recipient's Catalog No.	
4. Title and Subtitle <b>RANDOM HARMONIC ANALYSIS PROGRAM, L221 (TEV156) Volume I: Engineering and Usage</b>		5. Report Date <b>October 1979</b>	
		6. Performing Organization Code <b>D6-44466</b>	
7. Author(s) <b>R. D. Miller and M. L. Graham</b>		8. Performing Organization Report No.	
		10. Work Unit No.	
9. Performing Organization Name and Address <b>Boeing Commercial Airplane Company P.O. Box 3707 Seattle, Washington 98124</b>		11. Contract or Grant No. <b>NAS1-13918</b>	
		13. Type of Report and Period Covered <b>Contractor Report May 1975-May 1977</b>	
12. Sponsoring Agency Name and Address <b>National Aeronautics and Space Administration Washington, DC 20546</b>		14. Sponsoring Agency Code	
		15. Supplementary Notes <b>Langley Technical Monitors: Robert C. Goetz and Boyd Perry III Topical Report</b>	
16. Abstract  <p>L221 (TEV156) is a digital computer program available for execution on the CDC 6600. The program is capable of calculating steady state solutions for linear second-order differential equations due to sinusoidal forcing functions. From this steady state solution, generalized coordinates and load frequency responses may be determined. Statistical characteristics of loads for the forcing function spectral shape may also be calculated using random harmonic analysis techniques.</p> <p>The particular field of application of the program is the analysis of airplane response and loads due to continuous random air turbulence. Optional capabilities include frequency-dependent input matrices, feedback damping, gradual gust penetration, multiple excitation forcing functions, and a static-elastic solution.</p> <p>Program usage and a brief description of the analysis used are presented in volume I of this document. Volume II contains a description of the design and structure of the program to aid those persons who will maintain and/or modify the program in the future.</p>			
17. Key Words (Suggested by Author(s)) <b>Power Spectral Density (PSD) Frequency Response Dynamic Loads</b>		18. Distribution Statement <b>Unclassified-Unlimited</b>  <b>Subject Category 02</b>	
19. Security Classif. (of this report) <b>Unclassified</b>	20. Security Classif. (of this page) <b>Unclassified</b>	21. No. of Pages <b>155</b>	22. Price* <b>\$8.00</b>