



NASA-TM-81379 19800005258

NASA Technical Memorandum 81379

COMPARISON TESTS AND EXPERIMENTAL COMPLIANCE  
CALIBRATION OF THE PROPOSED STANDARD ROUND  
COMPACT PLANE STRAIN FRACTURE  
TOUGHNESS SPECIMEN

D. M. Fisher and R. J. Buzzard  
Lewis Research Center  
Cleveland, Ohio 44135

November 1979

NOV 15 1979  
LEWIS RESEARCH CENTER  
CLEVELAND, OHIO

COMPARISON TESTS AND EXPERIMENTAL COMPLIANCE CALIBRATION  
OF THE PROPOSED STANDARD ROUND COMPACT PLANE STRAIN  
FRACTURE TOUGHNESS SPECIMEN

by D. M. Fisher and R. J. Buzzard

National Aeronautics and Space Administration  
Lewis Research Center  
Cleveland, Ohio 44135

SUMMARY

Prior to its acceptance as a standard plane strain fracture toughness specimen to accompany the bend, rectangular compact, and C-shaped specimens, the round compact specimen was examined in three respects: 1) a comparison of  $K_{IC}$  results from the round specimen with those from rectangular compact specimens machined from the same round bar material; 2) an examination of the strength of the specimen in the region of the loading pin holes; and 3) experimental compliance measurements and a derived stress intensity factor calibration for comparison with existing analytical solutions. Acceptable agreement was found between the round and rectangular compact fracture toughness results. The proposed location of the loading pin holes was found to provide adequate specimen strength for plane strain fracture toughness testing. Excellent agreement was found between the stress intensity factor values from compliance measurements and values obtained from the analytic solution proposed for inclusion in the standard test method. Experimental compliances were determined from displacements at midthickness of the specimen on the surfaces of the loading holes. The displacement measurements were attained by means of long armed displacement gages with sharp registry points. These points extended through small holes in the walls of tubular loading cylinders. The loading cylinders had sufficient wall thickness to equate their loading characteristics to solid pins of equal outside diameter.

INTRODUCTION

A truncated round compact specimen is currently under consideration as a fourth ANSI/ASTM standard specimen for the measurement of plane strain fracture toughness ( $K_{IC}$ ). The three standard specimens it would join in ANSI/ASTM test method E-399 (1) are the three point bend, the rectangular compact, and the C-shaped. Use of the round compact specimen can provide machining economies when materials are supplied in solid cylindrical form. Test fixtures are the same as those used for the rectangular compact specimen, and the test characteristics are designed to be very similar.

This report describes tests involving three areas which must be considered prior to the adoption of the proposed round

compact specimen design as a standard. The first area considered was the comparison of fracture test results from five replicate round compact specimens with results obtained at another laboratory which used standard rectangular compact specimens machined from the same material and having the same crack orientation.

Second, ligament yielding, plastic deformation at the specimen's minimum section between the loading pin holes and the specimen periphery, was examined. Deformation was of concern since there is a smaller load supporting section between the loading pin holes and the specimen periphery than in the rectangular compact. Ligament yielding was measured in the five comparison fracture toughness specimens and also in an aluminum alloy specimen which was specifically dimensioned so that the maximum testing capacity of the specimen would be attained. This capacity is dictated by test method E-399 requirements that the specimen thickness (B) and crack length (a) shall exceed  $2.5 (K_{IC}/\sigma_{YS})^2$ ; where  $\sigma_{YS}$  is the material's 0.2% offset yield strength.

The third area of consideration was the determination of an experimental stress intensity calibration of the proposed standard specimen geometry. This calibration is derived from differentiation of load versus load point displacement slopes determined over a range of increasing crack lengths and results in a relationship of the stress intensity factor K with the ratio of crack length to specimen width. The experimental calibration was performed particularly for comparison with analytical results which would be the basis for  $K_{IC}$  computation in the test method.

#### FRACTURE TOUGHNESS COMPARISON TESTS

The following two sections describe the round compact plane strain fracture toughness tests and results. The results are compared with those obtained from standard rectangular compact specimens.

##### Comparison Test Procedure

Material for the fracture toughness comparison tests was obtained from a 76.2 mm diameter bar of a Ni-Cr-Mo steel similar to AISI 4335. The steel bar had been heat treated to 0.2% yield and ultimate strengths of 1286 and 1403 MPa respectively. Figure 1 depicts the specimen. Specimens were fatigue cracked and tested according to the procedures provided for the rectangular compact specimen in reference 1. The crack mouth displacement gage was calibrated so that the displacements could be established for comparison with the compliance specimens and analytical results. Plane strain fracture toughness values were calculated using Newman's (2) wide range analytic expression for the round compact specimens:

$$KBW^{1/2} = \frac{[2+a/W] [0.76+4.8a/W-11.58(a/W)^2+11.43(a/W)^3-4.08(a/W)^4]}{(1-a/W)^{3/2}}$$

Ligament yielding was determined from 5.08 mm sided squares scribed at the area of minimum ligament (Figure 2, upper half). Scribing was performed with the machinist's microscope attachment developed by Buzzard (3). Two sides of the squares were approximately parallel to the loading hole tangent at the point of minimum ligament. Central distances between the parallel sides of the squares were measured before and after the specimens were tested.

#### Results of Comparison Fracture Tests

Results of the  $K_{IC}$  tests of the round compact comparison tests are tabulated in Table I with those of the rectangular compact specimens tested at Watervliet Arsenal (4). The range of values for the round compacts was 102.3-106.4  $\text{MPa}\sqrt{\text{m}}$  (average 104.4) and that of the rectangular specimens 102.6-110.3 (average 105.9). The average value obtained from the round specimens was 1.4% less than that of the rectangular. Due to the similarity of the round compact and the rectangular specimens it was deemed that the comparison tests described here plus a similar comparison between the round compact and the C-shaped specimen (4) would be sufficient to evaluate the round compact as a standard plane strain fracture toughness specimen.

#### LIGAMENT YIELDING

Plastic deformation in the minimum section between the specimen loading holes and periphery (termed "ligament yielding" for simplicity of discussion) was first examined in the five fracture toughness specimen tests. The procedure was outlined in the Comparison Test Procedure section. The results of the measurements on all five fracture specimens showed an average positive plastic elongation in the G dimension (Figure 2) of 0.04% and a contraction in the H dimension of 0.07%. This deformation was not considered to be of significance.

Since the controlling specimen dimensions, a and B, in the fracture specimens exceeded the minimum dimensions prescribed by the test method (see INTRODUCTION) by more than 60 percent, it was decided to examine the ligament yielding in a specimen where the testing capacity could be reached or exceeded. This specimen is also depicted in Figure 1 and its scribed grid illustrated in the lower part of Figure 2. Material was 6061-T651 aluminum alloy whose  $K_{IC}$  was estimated at 29.2  $\text{MPa}\sqrt{\text{m}}$  and  $\sigma_{ys}$  at 299 MPa. The minimum dimension for B and a in this case would be 23.7 mm. The specimen was loaded to failure at 47.15 kN corresponding to a stress intensity of approximately 68  $\text{MPa}\sqrt{\text{m}}$ , or more than twice the  $K_{IC}$  value for the material. The maximum deformations noted were 0.05 mm bows in each of the horizontal scribed lines immediately adjacent to the points of loading pin contact. It appears from this test that the specimen strength in the loading pin region of the round compact specimen should be adequate for most  $K_{IC}$  applications.

## STRESS INTENSITY COMPLIANCE CALIBRATION

As previously mentioned in the INTRODUCTION, an experimental stress intensity calibration of the round compact specimen was performed. This calibration was obtained primarily in order to evaluate the analytic expression for  $K_{IC}$  computation chosen for inclusion in the standard test method.

## Stress Intensity Calibration by the Compliance Method

The compliance method of determining the fracture toughness related crack-extension force ( $\mathcal{G}$ ) calibration of a crack specimen type was established by Irwin and Kies (5). A complete discussion of the principle and method is found in reference 6 (Bubsey et al.). The compliance method is based on the relationship:

$$\frac{dC}{d(a/W)} = \frac{2B\mathcal{G}_I W}{P^2}$$

where C is compliance, that is, load point displacement (f) per applied force (P); a is crack length; W specimen width; and B specimen thickness. For convenience the compliance is often described in the non-dimensional form,  $EfB/P$ , where E is the material's elastic modulus in tension. In practice a series of compliance values is obtained for increasing crack lengths with the crack approximated by a saw cut. A fitting function relating compliance with crack length to width ratio is then determined. Differentiation of this function provides the relationship of crack extension force to load and specific dimensions for any specimen of similar planar geometry.

The calibration reported here can be considered as being obtained from conditions approaching plane stress since a very small volume of the specimen approximates a plane strain state. A discussion of the relation of  $\mathcal{G}_I$  and  $K_I$  in regard to the stress state attained in a calibration specimen as compared with that treated in an analytical solution is provided in reference 6.

## Compliance Specimens and Displacement Measurement Locations

Compliance calibrations were made on two varieties of the round compact specimen, the full round and the truncated. Both specimens are illustrated in Figure 1. The geometry for the specimen proposed for inclusion in the standard test method was changed from the full round to the truncated during the course of this investigation. It was decided to calibrate the truncated version, not only because it represented the final version of the specimen, but also because additional information could be obtained by the inclusion of load point displacement measurements.

Displacement measurements on the full round specimen were made on the notch surface in three locations: on the load line, at the crack mouth, and at a point half way between the other two. For the truncated specimen, displacements were measured at the load points, load line, and crack mouth, as defined by Figure 1.

#### Compliance Procedure

The specimen material was 6061-T651 aluminum alloy with an elastic modulus of  $6.89 \times 10^4$  MPa. The saw slot simulating a crack was 0.61 mm in width.

Displacements were measured at the specimen midthickness using the standard knife edge mounting clip gage for the crack mouth and point mounting variations of the standard gage for all the other displacements. Gages were calibrated prior to and following a compliance run, over the gage opening range encountered in each compliance run for a given crack length to width ratio. Calibrations were made using an extensometer calibrator reading to a least division of 0.00127 mm. The gages were calibrated to the XYY' recorder channel on which the test displacement was registered.

Least squares linear regressions were run on all calibrations and the observed load-displacement slopes corrected accordingly. This procedure eliminated the need for exact adjustment of displacement gage excitation voltages with changes in recorder scales or amplifier amplifications. It also reduced any error which might have occurred due to any slight non-linearities in the recorder calibrations.

A single 44.5 kN load cell was used for all compliance determinations. Slight modifications in excitation voltage were made based on the applicable load range. These adjustments were based on calibration of the load cell to a proving ring for loads exceeding 4.45 kN and to a dead weight system incorporating a 10:1 lever arm 1.016 m in length for loads of 4.45 kN or less. Calibrating resistor checks were made prior to every compliance series. The loading pin contact surfaces of the loading clevises were flat to reduce frictional effects.

Load-displacement slopes were recorded on XYY' pen recorders. Four slope determinations were made of each crack length variation and the last three averaged for record. The first loading slope was disregarded in case it included irregularities due to load train alignment. A slight residual load was kept on the specimen between the four runs.

## Load Point Displacement

On completion of the compliance calibration of the full round specimen, it was recognized that load point displacement measurements would provide valuable information additional to that obtainable from the load line and crack mouth displacements. A method was developed to measure load displacement in the load application area at mid-thickness by use of hollow loading cylinders and a long armed variation of a standard double beamed displacement gage. Figure 3 illustrates this method, which was used only for the truncated specimen tests. Points mounted on the ends of the gage beams protrude through 4.8 mm diameter holes in the loading tube walls and register directly on the mid-thickness points of the loading holes center line. In the development of the load point displacement procedure the original loading tubes had a wall thickness of approximately 2.5 mm. These loading tubes were used for determination of the ratio between the load point displacement and the load line displacement. These data were obtained in full round specimens of  $a/W$  equal to 0.187 with the notch tip a 4.8 mm radius, and of  $a/W = 0.877$  with a sawed slot notch tip. The load point to load line displacement ratios determined were 1.033 and 1.026 respectively. It was later recognized that the wall thickness of these load tubes was insufficient to produce slopes equal to those obtained from solid loading pins. This fact was overlooked in the original analysis of the ratio records but these results were reported by Gross (7).

The loading tubes used for the truncated round specimen were aged 300 grade maraging steel with a wall thickness of 5.38-5.44 mm. As detailed later, these loading tubes resulted in crack mouth and load line displacements equal to those obtained with solid loading pins of the same outside diameter.

Loading pin diameters used in the full round compliance specimen were 38.02 mm, resulting in a 0.11 mm clearance with the specimen loading holes. Loading pin diameters in the truncated round compliance runs were 36.57 mm. The reduction in pin diameter was made to comply with test method specifications for the standard compact. A comparison of compliance variation obtained with the two loading pin sizes was made at  $a/W$  equal to 0.198 and is discussed later.

## Compliance Results

Experimental compliance values ( $EfB/P$ ) for both specimen variations are tabulated in Table IIA. Polynomials were fitted to these results by Dr. Bernard Gross, NASA Lewis Research Center, and the corresponding values obtained from these polynomials are listed with their percent variation from the experimental values. The range of variation of all polynomial values from the corresponding experimental values was +1.2 to -1.4

percent. The least variation range for any combination of specimen type and displacement location was +0.8 to -0.8 percent for the load point displacement location of the truncated specimen. The polynomial coefficients are given in Table IIB. No polynomial was fitted to the intermediate displacement values and these data are presented for information only.

A comparison of the experimentally derived compliance values with analytical values is provided in Table III. For the full round specimen, values for the load line and crack mouth locations are compared with Gross (7) and Newman (2). For the truncated version; load line, load point, and crack mouth values are compared with Newman (2).

Overall agreement of all comparable values was generally good. An exception was at the lower values of  $a/W$  where the modeling of the load distribution on the pin hole apparently becomes critical in the analytic solutions.

Table IV details the corresponding stress intensity coefficients,  $KB\sqrt{W}/P$ , derived from the polynomials for load line and load point displacements. For that  $a/W$  range of 0.45 through 0.55 prescribed for ASTM E399 test method specimens, the use of the load line or load point displacement makes little difference. This is also the case for  $a/W$  values greater than this range. At the values below this range the difference between those stress intensity factors determined from the load line and load point displacements generally increases to a maximum at the  $a/W = 0.20$  value. This further illustrates the importance of the modeling of the load distribution in the analytic treatments.

Figure 4 portrays the problem encountered in the use of the load line displacements for the determination of the stress intensity in the round compact specimen. The figure shows the differences in compliance between the load point and load line displacement locations. In order for the load line location to be totally acceptable for determination of a stress intensity relation, the difference should be constant over the  $a/W$  range specified. The slopes of the load line and load point versus  $a/W$  would then be identical at any specific value of  $a/W$ . It would appear that this condition is reasonably well met by the load line displacements in the  $a/W$  range of 0.45 to 0.55. Above that range the importance of the difference is significantly reduced in that it represents a continually smaller percentage of the total compliance value and has an even smaller effect on the slope.

As a final observation in examining Table IV, the excellent agreement between the experimental values of the stress intensity factors determined from load point displacements with



those of Newman should be noted. The agreement over the range of  $a/W$  from 0.25 through 0.80 is  $\pm 0.4$  percent.

#### Loading Pin Comparisons

In determining that the 5.4 mm wall tubing was sufficiently stiff to equate compliance values obtained using the hollow loading tubes with those using solid pins, comparison runs were made for three specimen variations. These variations were: the full round specimen with  $a/W$  of 0.187 (4.8 mm radius tip) and 0.198 (saw slot tip) and the truncated specimen with an  $a/W$  of 0.198 (saw slot tip). The compliances obtained from the hollow pins varied from those determined with solid pins by +0.3 to -0.6% at the load line and from 0 to -0.1% at the crack mouth. Based on these results it was concluded that the loading tubes were sufficiently stiff, and compliance data at greater  $a/W$  values were then obtained only with those tubes.

A similar comparison was made with these three specimen variations for the two solid loading pin diameter variations. Compliance values obtained from the tighter pin fit ranged +0.5 to +2.4% greater at the load line location and +1.1 to -1.0% at the crack mouth.

#### Fracture Toughness Specimen Compliance

As previously mentioned in the Fracture Toughness Comparison Tests Section, the clip gage used in the fatigue cracked comparison specimen tests was calibrated so that crack mouth compliance values could be determined from the elastic portion of the test records. These actual crack compliance values are provided in Figure 5 for comparison with the analytically derived polynomials of Newman and Gross and that derived from the experimental results for the full round specimen reported herein. The results are primarily of interest in that they are obtained from actual crack specimens with the crack length determined by an averaging of three measurements per the ASTM E399 test method. The test specimen values fall between the Gross and Newman solutions but favor that of Newman.

#### SUMMARY AND CONCLUSIONS

Plane strain fracture toughness tests comparing round compact specimen results with those obtained from standard rectangular compact specimens showed sufficiently satisfactory correspondence for inclusion of the round specimen in the standard test method. Examination of yielding in the loading hole vicinity indicated that the hole location provides adequate strength for use of the specimen in plane strain fracture toughness testing.

The stress intensity calibration for the proposed standard specimen geometry, derived from experimental compliance results, agreed extremely well with the Newman analytical solution over an  $a/W$  range of 0.25 - 0.85. This reinforces the choice of that analytical expression for inclusion in the ASTM E399 test method. Analytic solutions which do not model the pin loading very closely may produce acceptable stress intensity solutions in and beyond the crack length to width range specified for  $K_{IC}$  testing, but are at variance below that range.

#### REFERENCES

1. Standard Method of Test for Plane-Strain Fracture Toughness of Metallic Materials; Designation E399-78. Annual Book of ASTM Standards, Pt. 10. Am. Soc. Test. Mater., 1978, pp. 512-533.
2. Newman, J.C.: Stress-Intensity Factors and Crack-Opening Displacements for Round Compact Specimens. NASA TM 80174, 1979.
3. Buzzard, R. J.: Precision Scriber. NASA Tech Brief No. LEW 12976.
4. Underwood, J. H.; Newman, J. C.; and Seeley, R. R.: A Proposed Standard Round Compact Specimen for  $K_{IC}$  Testing. To be published.
5. Irwin, G. R., and Kies, J. A.: Critical Energy Rate Analysis of Fracture Strength. Welding Jour. Res. Supplement, Vol. 33, 1954, pp. 193S-198S.
6. Bubsey, R. T.; Fisher, D. M.; Jones, M. H.; and Srawley, J. E.: Compliance Measurements. SESA Monograph No. 1: Experimental Techniques in Fracture Mechanics. The Iowa State University Press, 1973, pp. 76-95.
7. Gross, B.: Mode I Crack Surface Displacements for a Round Compact Specimen Subject to a Couple and Force. NASA TM 79096, 1979.

ROUND COMPACT

SPEC NO.	SPECIMEN DIMENSIONS (SEE FIG. 1)				DIMENSION RATIOS		STRESS INTENSITY COEFFICIENT	SECANT INTEREST LOAD,	CONDITIONAL FRACTURE TOUGHNESS,	MAY. LOAD TO SECANT LOAD,	LOADING RATE	K <sub>max</sub> IN FATIGUE PREPARATION (K <sub>F</sub> )	SPECIMEN SIZE FACTOR, 2.5 (K <sub>Q</sub> /σ <sub>YS</sub> ) <sup>2</sup>	RECTANGULAR COMPACT (REF. 4) CONDITIONAL FRACTURE TOUGHNESS, K <sub>Q</sub>
	B (mm)	W (mm)	D (mm)	a (mm)	D/W	a/W	$\frac{KB\sqrt{W}}{P}$ ①	P <sub>Q</sub> (KN)	K <sub>Q</sub> (MPa√m)	$\frac{P_{max}}{P_Q}$	(MPa√m/sec.)	$\frac{K_{max}}{K_Q}$	(mm)	K <sub>Q</sub> (MPa√m)
1	27.35	54.62	73.11	27.43	1.34	.502	10.2395	65.56	105.0	1.09	.50	.14	16.8	105.9
2	27.35	54.62		27.43		.502	10.2395	63.87	102.3	1.08	.93	.13	15.7	102.6
3	27.32	54.58		27.25		.506	10.1735	66.01	105.2	1.09	.98	.14	16.8	104.8
4	27.35	54.60		27.20		.498	10.1081	65.12	103.0	1.13	.60	.14	16.0	110.3
5	27.35	54.61	Y	27.76	Y	.509	10.4755	64.94	106.4	1.09	1.18	.13 ②	17.0	
AVG. 104.4														105.9

$$\textcircled{1} \frac{KB\sqrt{W}}{P} = \left[ \frac{2 + a/W}{(1 - a/W)^{3/2}} \right] \left[ 0.76 + 4.8 \frac{a}{W} - 11.58 \left( \frac{a}{W} \right)^2 + 11.43 \left( \frac{a}{W} \right)^3 - 4.08 \left( \frac{a}{W} \right)^4 \right] \text{ (REF. 2)}$$

② SPECIMEN LOADED TO 58% OF P<sub>Q</sub> AND UNLOADED PRIOR TO REPORTED TEST LOAD.

TABLE I. FRACTURE TOUGHNESS COMPARISON TEST RESULTS

DIMENSIONLESS COMPLIANCE,  $\frac{E\delta B}{P}$

CRACK LENGTH TO WIDTH RATIO	FULL ROUND SPECIMEN DISPLACEMENTS MEASURED AT							CRACK LENGTH TO WIDTH RATIO	TRUNCATED ROUND SPECIMEN DISPLACEMENTS MEASURED AT								
	LOAD LINE			CRACK MOUTH			INTER-MEDIATE		LOAD LINE			LOAD POINT			CRACK MOUTH		
	a/W	EXP. VALUE	POLY. ①	% VAR.	EXP. VALUE	POLY. ②			% VAR.	EXP. VALUE	POLY. ③	% VAR.	EXP. VALUE	POLY. ④	% VAR.	EXP. VALUE	POLY. ⑤
.187	7.77	7.77	0	16.79	16.82	+0.2	13.33	.198	8.04	8.03	-0.1	13.53	13.54	+0.1	16.13	16.07	-0.3
.212	8.92	8.97	+0.6	18.43	18.40	-0.2	14.66	.225	9.18	9.22	+0.4	14.65	14.56	-0.6	17.45	17.55	+0.6
.252	11.00	10.85	-1.4	21.26	21.16	-0.5	16.96	.249	10.51	10.41	-1.0	15.51	15.61	+0.6	19.14	19.09	-0.3
.299	13.56	13.68	+0.6	24.82	25.09	+1.1	19.88	.275	11.76	11.88	+1.0	16.88	16.92	+0.2	20.92	21.00	+0.4
.350	17.19	17.39	+1.2	30.51	30.31	-0.7	24.62	.301	13.54	13.55	+0.1	18.36	18.45	+0.5	23.10	23.21	+0.5
.375	19.79	19.62	-0.9	33.71	33.51	-0.6	27.15	.326	15.43	15.38	-0.3	20.23	20.15	-0.4	25.79	25.63	-0.6
.399	21.99	22.07	+0.4	36.73	37.07	+0.9	30.25	.350	17.42	17.38	-0.2	22.20	22.03	-0.8	28.35	28.27	-0.3
.424	25.24	25.04	-0.8	41.35	41.40	-0.4	34.38	.400	22.37	22.46	+0.4	26.90	26.93	+0.1	34.98	34.96	-0.1
.451	28.66	28.68	+0.1	46.47	46.71	+0.5	38.62	.450	29.22	29.15	-0.2	33.48	33.51	+0.1	43.69	43.65	-0.1
.476	32.73	32.66	-0.2	52.61	52.53	-0.2	43.49	.501	38.35	38.30	-0.1	42.44	42.65	+0.5	55.52	55.41	-0.2
.501	37.81	37.57	-0.6	60.31	59.67	-1.1	49.99	.549	50.08	50.05	-0.1	54.55	54.47	-0.1	69.58	70.41	+1.2
.525	42.75	42.91	+0.4	66.77	67.39	+0.9	55.53	.600	67.32	67.67	+0.5	72.58	72.26	-0.4	93.20	92.90	-0.3
.551	49.63	49.70	+0.1	77.26	77.13	-0.2	64.2	.650	93.21	93.42	+0.2	99.42	98.19	+0.8	126.0	125.9	-0.1
.574	56.48	57.16	+1.2	87.65	87.73	+0.1	72.01	.700	134.7	134.1	-0.4	140.0	139.1	-0.6	179.6	178.4	-0.7
.600	67.52	67.31	-0.3	102.1	102.0	-0.1	85.15	.749	203.3	201.8	-0.7	207.4	206.9	-0.2	266.0	265.9	0
.651	94.34	93.89	-0.7	139.0	139.0	0	116.1	.800	330.6	333.9	+1.0	338.0	340.1	+0.6	432.7	436.2	+0.8
.700	133.5	133.6	+0.1	192.6	193.7	+0.6	161.6	.850	610.1	608.2	-0.3	621.4	620.0	-0.2	786.9	784.2	-0.3
.749	199.4	199.1	-0.2	286.0	283.8	-0.8	241.7										
.801	331.4	331.3	0	465.0	465.8	+0.2	395.5										
.852	619.6	622.0	+0.4	860.7	863.3	+0.3	723.8										
.877	919.4	917.2	-0.2	1244.	1242.	-0.2	1084.										

TABLE II A - EXPERIMENTALLY DETERMINED COMPLIANCE VALUES WITH THE COMPARABLE VALUES FROM THE FITTED POLYNOMIALS (TABLE II B).

## COMPLIANCE POLYNOMIALS

$$\ln \left[ \frac{E f B}{P} \right] = A + B \left( \frac{a}{W} \right) + C \left( \frac{a}{W} \right)^2 + D \left( \frac{a}{W} \right)^3 + \dots$$

SPECIMEN	DISPLACEMENT, $f$ , LOCATION *	COEFFICIENTS						
		A	B	C	D	E	F	G
FULL ROUND ↓	① LOAD LINE	.998	4.849	14.436	-85.001	198.281	-207.985	84.433
	② CRACK MOUTH	1.880	7.371	-17.569	27.201	11.196	-56.290	36.366
TRUNCATED ↓	③ LOAD LINE	.973	6.573	-8.117	21.532	-29.248	17.488	—
	④ LOAD POINT	2.161	2.511	-5.834	30.618	-45.072	24.958	—
	⑤ CRACK MOUTH	2.456	-.483	13.966	-18.708	8.493	3.571	—

\* SEE FIG. 1

TABLE IIB — COEFFICIENTS OF POLYNOMIALS FIT TO EXPERIMENTAL COMPLIANCE VALUES

DIMENSIONLESS COMPLIANCE,  $\frac{EFB}{P}$

a/w	FULL ROUND SPECIMEN						TRUNCATED SPECIMEN					
	AT LOAD LINE			AT CRACK MOUTH			AT LOAD LINE		AT LOAD POINT		AT CRACK MOUTH	
	EXPERIMENTAL	GROSS [7]	NEWMAN [2]	EXPERIMENTAL	GROSS [7]	NEWMAN [2]	EXPERIMENTAL	NEWMAN [2]	EXPERIMENTAL	NEWMAN [2]	EXPERIMENTAL	NEWMAN [2]
.20	8.34	8.32	7.82	17.65	18.46	17.53	8.12	7.80	13.61	14.18	16.17	15.95
.25	10.77	10.85	10.32	21.05	22.03	20.92	10.46	10.30	15.66	16.19	19.15	19.01
.30	13.72	14.11	13.42	25.14	26.79	25.30	13.48	13.39	18.38	18.92	23.11	22.96
.35	17.41	18.15	17.32	30.35	32.70	30.94	17.38	17.29	22.03	22.60	28.27	28.06
.40	22.18	23.18	22.36	37.22	40.02	38.26	22.46	22.32	26.93	27.48	34.96	34.70
.45	28.54	29.68	28.96	46.52	49.42	47.86	29.15	28.94	33.51	34.02	43.65	43.42
.50	37.28	38.46	37.84	59.26	62.05	60.68	38.09	37.82	42.44	42.90	55.15	55.12
.55	49.55	50.79	50.12	76.92	79.70	78.28	50.33	50.08	54.76	55.18	70.77	71.20
.60	67.18	68.63	67.62	101.8	105.1	103.2	67.67	67.60	72.26	72.72	92.90	94.02
.65	93.25	95.14	93.68	138.1	142.5	140.0	93.42	93.68	98.19	98.84	125.9	127.8
.70	133.6	136.1	134.7	193.7	199.9	197.5	134.1	134.7	139.1	139.9	178.4	180.6
.75	201.0	204.1	204.0	286.5	294.5	294.0	203.6	204.0	208.8	209.4	268.2	269.4
.80	321.7	331.7	334.4	460.9	470.8	474.4	334.0	334.6	340.1	339.8	436.2	435.6

TABLE III - COMPARISON OF FULL ROUND AND TRUNCATED ROUND COMPACT SPECIMEN COMPLIANCE VALUES OBTAINED FROM ANALYTICALLY AND EXPERIMENTALLY DERIVED POLYNOMIALS.

STRESS INTENSITY COEFFICIENT,  $\frac{KB\sqrt{W}}{P}$

$a/W$	FULL ROUND SPECIMEN			TRUNCATED SPECIMEN		
	LOAD LINE		LOAD POINT	LOAD LINE	LOAD POINT	
	EXPERIMENTAL	GROSS [7]	NEWMAN [2]	EXPERIMENTAL	EXPERIMENTAL	NEWMAN [2]
.20	4.69	4.77	4.14	4.56	4.21	4.12
.25	5.16	5.28	4.85	5.15	4.85	4.84
.30	5.73	5.89	5.64	5.84	5.61	5.63
.35	6.45	6.64	6.51	6.66	6.49	6.50
.40	7.39	7.56	7.51	7.62	7.52	7.51
.45	8.60	8.71	8.70	8.77	8.73	8.70
.50	10.13	10.17	10.17	10.18	10.20	10.17
.55	12.07	12.07	12.05	12.00	12.05	12.05
.60	14.55	14.57	14.52	14.42	14.49	14.53
.65	17.85	18.00	17.92	17.81	17.86	17.93
.70	22.54	22.88	22.81	22.76	22.80	22.82
.75	29.81	30.28	30.28	30.34	30.40	30.29
.80	42.21	42.56	42.75	42.55	42.80	42.76

TABLE IV - ANALYTICALLY AND EXPERIMENTALLY DERIVED STRESS INTENSITY COEFFICIENTS FOR THE FULL ROUND AND TRUNCATED ROUND COMPACT SPECIMENS.

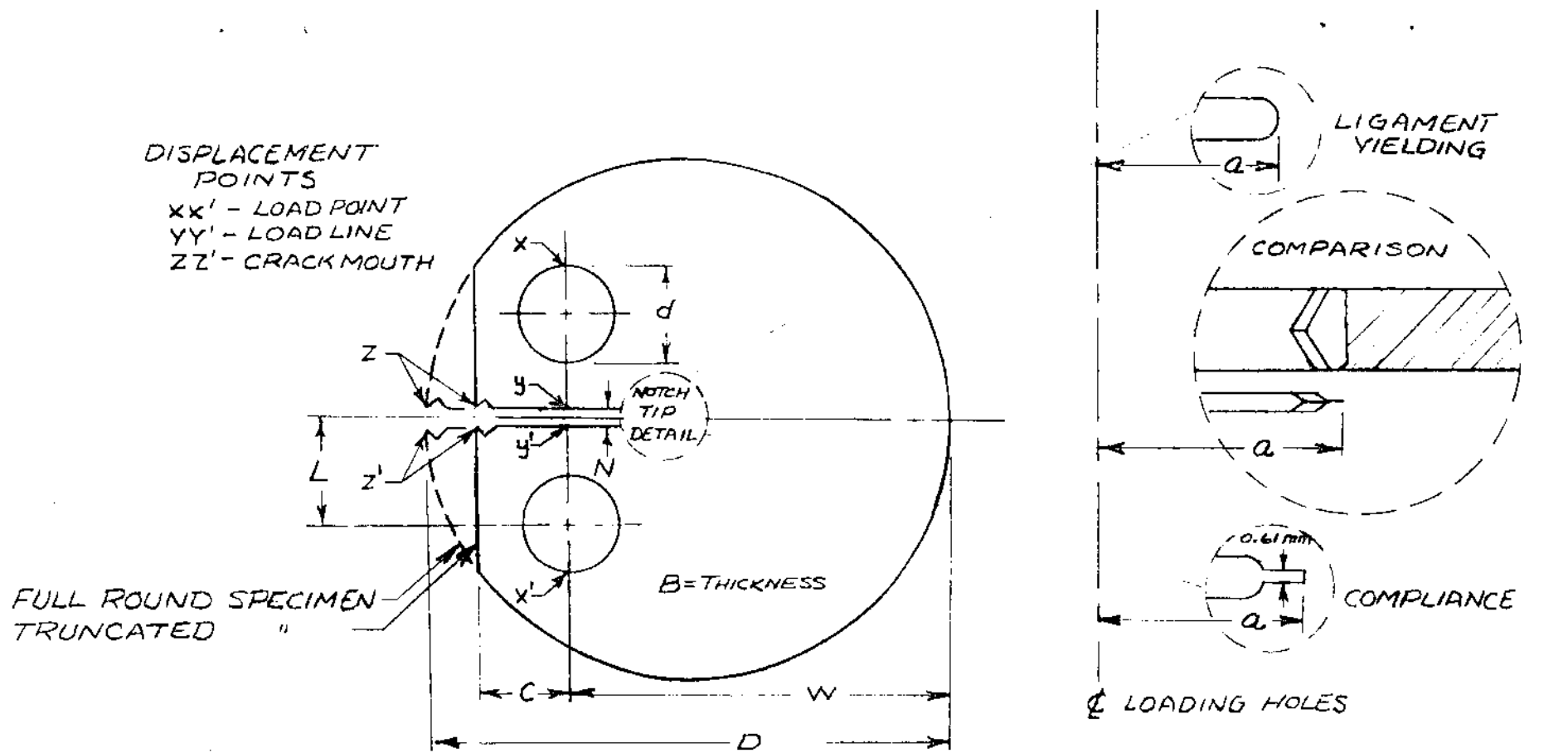

DIMENSION RATIOS  
 FOR PROPOSED  
 STANDARD SPECIMEN

$$D/W = 1.35$$

$$L/W = 0.275$$

$$d/W = 0.25$$

$$a/W = .45-.55$$

$$C/W = 0.25$$

DIMENSION IDENTITY	SPECIMEN DIMENSIONS (mm.)		
	COMPLIANCE	SPECIMEN COMPARISON	LIGAMENT YIELDING
D	204.2	73.10	71.07
W	151.2	54.61	52.55
d	38.13	13.67	13.13
L	41.48	14.94	14.45
N	9.60	3.18	1.09
a	—	27.43	23.57
B	27.25	27.36	26.39
C	37.82	—	13.16

FIG. 1 - ROUND COMPACT SPECIMENS



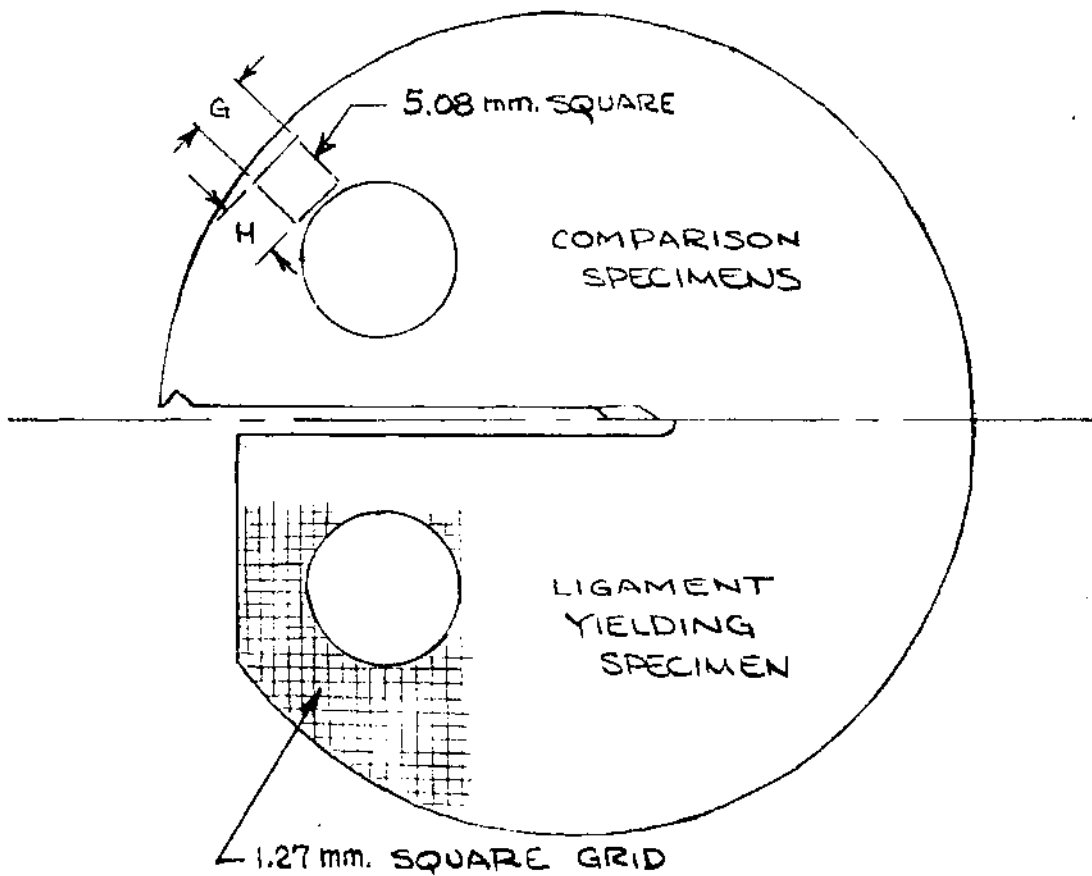

FIG. 2 - TWO VARIATIONS OF SCRIBING FOR EVALUATION OF PLASTIC DEFORMATION IN THE LOADING HOLE REGION (LIGAMENT YIELDING).

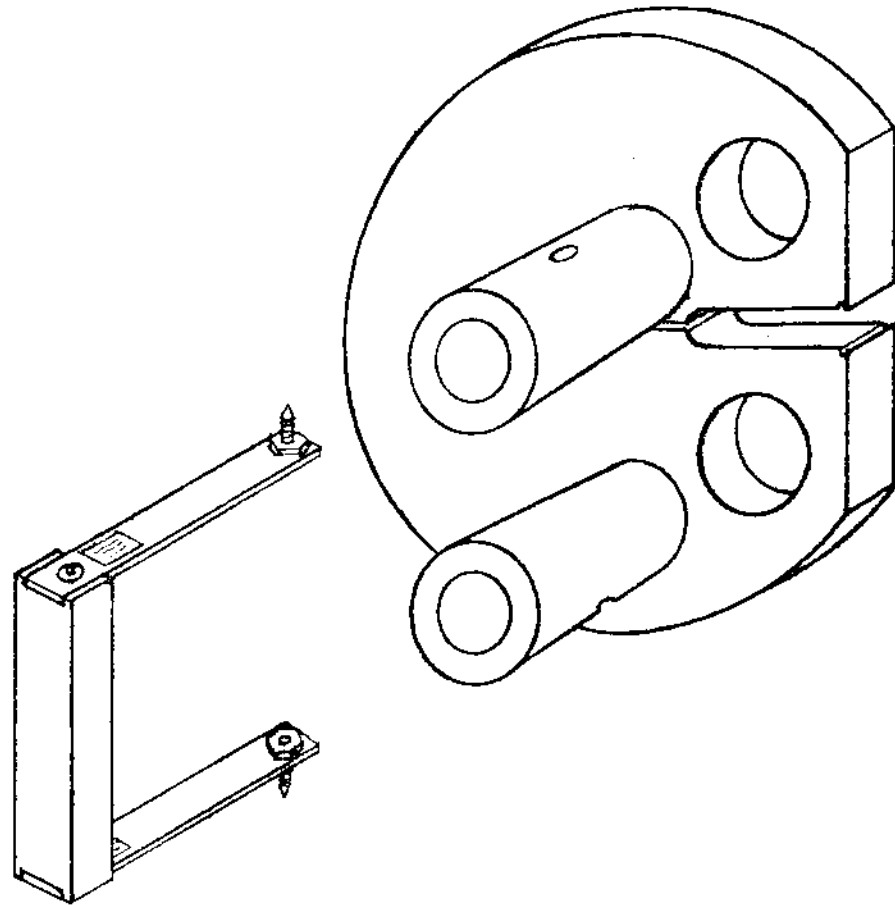

FIG. 3 - HOLLOW LOADING CYLINDERS  
AND POINT INDEXING GAGE FOR  
LOAD POINT DISPLACEMENT  
MEASUREMENTS.

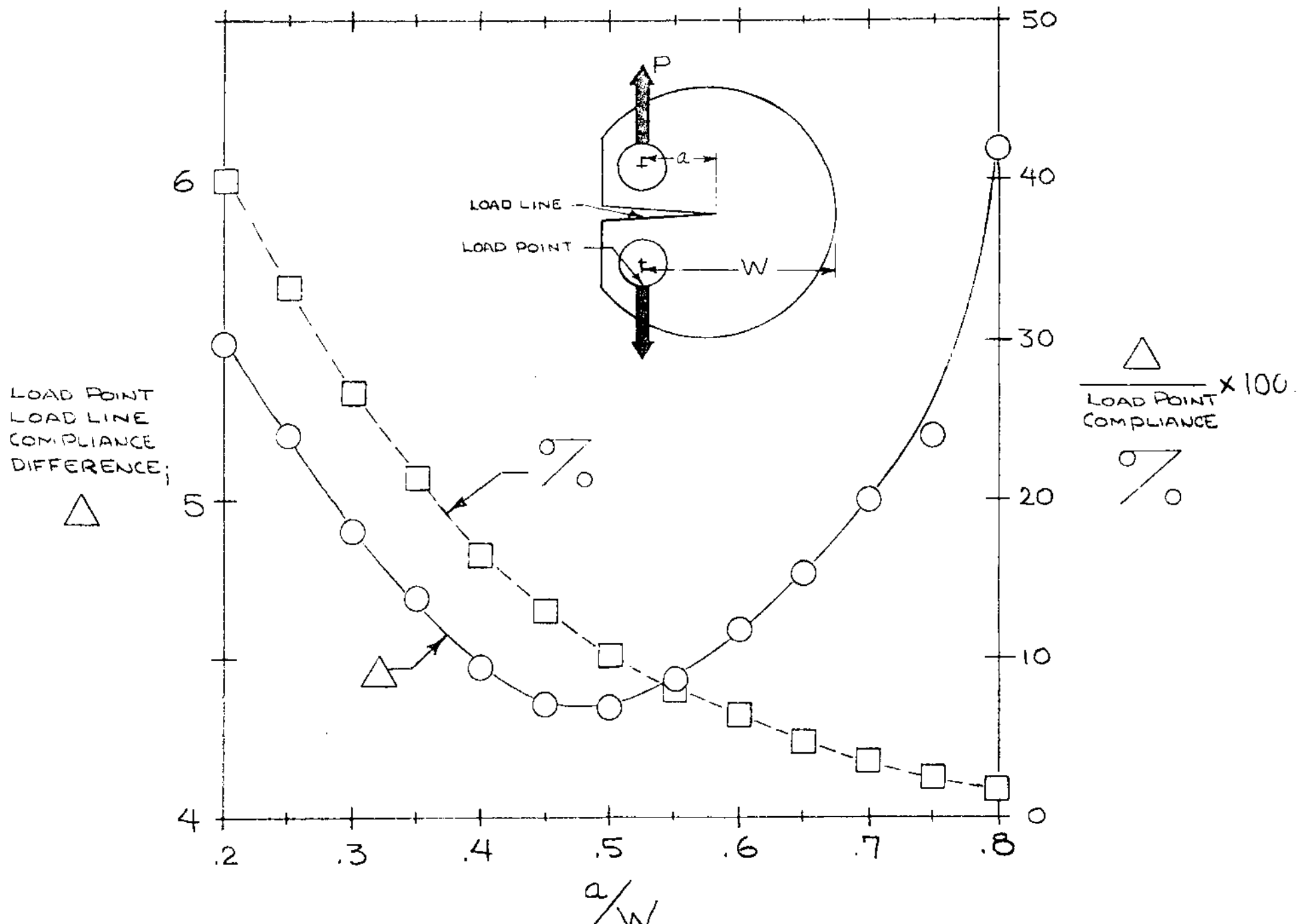

FIG. 4 - BOTH THE LOAD POINT - LOAD LINE COMPLIANCE DIFFERENCE AND THE DIFFERENCE AS A PER CENT OF LOAD POINT COMPLIANCE, VERSUS CRACK LENGTH TO WIDTH RATIO.

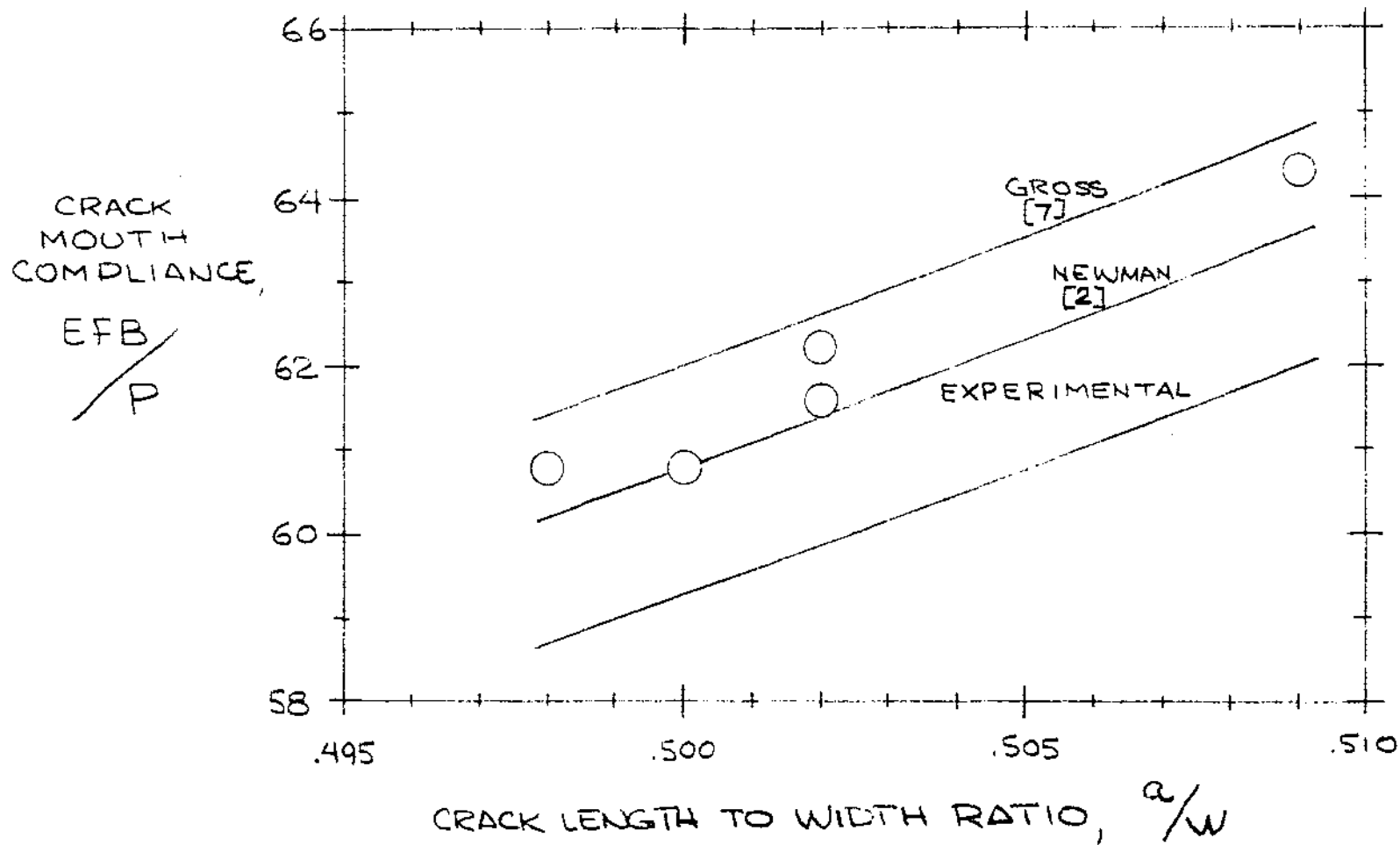

FIG.5 - COMPARISON OF FATIGUE CRACKED FULL ROUND SPECIMEN COMPLIANCES [O], WITH ANALYTIC AND EXPERIMENTAL POLYNOMIAL VALUES.

1. Report No. NASA TM-81379	2. Government Accession No.	3. Recipient's Catalog No.	
4. Title and Subtitle <b>COMPARISON TESTS AND EXPERIMENTAL COMPLIANCE CALIBRATION OF THE PROPOSED STANDARD ROUND COMPACT PLANE STRAIN FRACTURE TOUGHNESS SPECIMEN</b>		5. Report Date November 1979	6. Performing Organization Code
		8. Performing Organization Report No. E-284	10. Work Unit No.
7. Author(s) D. M. Fisher and R. J. Buzzard		11. Contract or Grant No.	
9. Performing Organization Name and Address National Aeronautics and Space Administration Lewis Research Center Cleveland, Ohio 44135		13. Type of Report and Period Covered Technical Memorandum	
		14. Sponsoring Agency Code	
12. Sponsoring Agency Name and Address National Aeronautics and Space Administration Washington, D.C. 20546		15. Supplementary Notes	
16. Abstract  Proposed standard round specimen fracture test results compared satisfactorily with results from standard rectangular compact specimens machined from the same material. The location of the loading pin holes was found to provide adequate strength in the load bearing region for plane strain fracture toughness testing. Excellent agreement was found between the stress intensity coefficient values obtained from compliance measurements and the analytic solution proposed for inclusion in the standard test method. Load displacement measurements were made using long armed displacement gages and hollow loading cylinders. Gage points registered on the loading hole surfaces through small holes in the walls of the loading cylinders.			
17. Key Words (Suggested by Author(s)) Round compact specimen; Test specimen; Materials testing; Fracture tests; Fracture toughness; Crack toughness; Toughness		18. Distribution Statement Unclassified - unlimited STAR Category 39	
19. Security Classif. (of this report) Unclassified	20. Security Classif. (of this page) Unclassified	21. No. of Pages	22. Price*

National Aeronautics and  
Space Administration

Washington, D.C.  
20546

Official Business

Penalty for Private Use, \$300

SPECIAL FOURTH CLASS MAIL  
BOOK

Postage and Fees Paid  
National Aeronautics and  
Space Administration  
NASA-451



**NASA**

POSTMASTER: If Undeliverable (Section 158  
Postal Manual) Do Not Return

---