

N O T I C E

THIS DOCUMENT HAS BEEN REPRODUCED FROM
MICROFICHE. ALTHOUGH IT IS RECOGNIZED THAT
CERTAIN PORTIONS ARE ILLEGIBLE, IT IS BEING RELEASED
IN THE INTEREST OF MAKING AVAILABLE AS MUCH
INFORMATION AS POSSIBLE

NASA Technical Memorandum 79320

(NASA-TM-79320) EFFICIENT LASER ANEMOMETER
FOR INTRA-ROTOR FLOW MAPPING IN
TURBOMACHINERY (NASA) 11 p HC A02/HP A01
CSCL 14B

N80-14375

Unclas
46441
G3/35

EFFICIENT LASER ANEMOMETER FOR
INTRA-ROTOR FLOW MAPPING
IN TURBOMACHINERY

J. Anthony Powell, Anthony J. Strazisar,
and Richard G. Seasholtz
Lewis Research Center
Cleveland, Ohio



Prepared for the
Twenty-fifth Annual International Gas Turbine Conference and
the Twenty-second Annual Fluids Engineering Conference
sponsored by the American Society of Mechanical Engineers
New Orleans, Louisiana, March 9-13, 1980

EFFICIENT LASER ANEMOMETER FOR INTRA-ROTOR FLOW

MAPPING IN TURBOMACHINERY

by J. Anthony Powell, Anthony J. Strazisar,
and Richard G. Seasholtz

National Aeronautics and Space Administration
Lewis Research Center
Cleveland, Ohio 44135

ABSTRACT

Innovative features of the anemometer include: (1) a rapid and efficient data acquisition process, (2) a detailed real-time graphic display of the data being accumulated, and (3) input laser beam positioning that maximizes the size of the intra-rotor region being mapped. Results are presented that demonstrate the anemometer's capability in flow mapping within a transonic axial-flow compressor rotor. Typically, a velocity profile, derived from 30 000 measurements along 1000 sequential circumferential positions covering 20 blade passages, can be obtained in 30 seconds. The use of fluorescent seed particles allows flow measurements near the rotor hub and the casing window.

INTRODUCTION

In order to improve the understanding of flow phenomena in turbomachinery, and to verify flow models used in analysis, detailed measurements of the internal flow field of the rotating components are needed. Increasingly, laser anemometry (1) is being used to answer this need. Several approaches to laser anemometry have been applied to turbomachinery. Among these are the fringe-type anemometer (sometimes called a laser Doppler velocimeter) (2,3) and the time-of-flight anemometer (4-6).

Since turbomachinery research facilities often consume large amounts of energy, there is an additional need that flow measurements be made as quickly as possible. In each of the systems described in (2,4-6), the laser was time-gated so that velocity measurements were accepted only during a small fraction of each revolution of the rotor. The reason for this is as follows. The probe volume, fixed at some axial and radial position, sweeps out a circumferential path within the rotating blade row. In each case, the circumferential path in a given blade passage was divided into a fixed number of line segments and the velocity for each segment was determined, one segment at a time. This was accomplished by turning the laser beam on (i.e. time-gating the laser) only when the desired line segment was in the field of view. In the system of (5,6), measurements from corresponding segments in successive blade passages were averaged in order to speed up the data taking rate. However, in all of the time-gated systems, the data acquisition process is very wasteful of facility run time. In the system described in (3), data are continuously collected from a circumferential path covering two blade passages. The individual measurements are then presented as marks on an oscilloscope display such that the vertical position of each mark represents the velocity and the horizontal position represents the circumferential location of the measurement. Measurements are recorded by photographing the oscilloscope display. This approach also does not lend itself to rapid and efficient data taking.

This paper describes a fringe-type laser anemometer (LA) with a data acquisition process which is

much more efficient. In this system, velocity measurements, at any given time, are accepted from any of 1000 line segments along the circumferential path. Each velocity measurement is tagged with the location of the line segment in which it occurred and the resulting data sorted out with a minicomputer. Also adding to the efficiency of the anemometer is a real-time graphic display that allows the evaluation of data being accumulated. The anemometer also makes use of techniques that minimize the portion of the intra-rotor region that cannot be mapped because of shadowing due to blade twist.

The anemometer was used to map the intra-rotor region of a transonic axial-flow compressor rotor. The rotor contained 52 blades and had an overall diameter of 50.8 cm. It was operated at a maximum speed of about 16 000 rpm. Sufficient results are presented to demonstrate the capability of the anemometer. This particular application is discussed in detail in another paper (7).

DESCRIPTION OF SYSTEM HARDWARE

Brief Overall Description

Figure 1 shows the basic optical components of the LA. It is a fringe-type, on-axis, backscatter system that uses the 514.5 nm line of an argon-ion laser. In a fringe-type LA, the flow velocity is determined by measuring the transit time required for a seed particle to traverse laser fringes of known spacing. The fringes occur at the intersection (called the probe volume) of the two laser beams. The particular velocity component being measured lies in the plane of the two beams and is perpendicular to the bisector of the two beams. The component is selected by rotating the splitter to the required angle. Optical access to within the rotor blade row is made along an approximately radial path through a window in the casing around the rotor. The motorized-goniometer mirror mount, shown in the figure, allows the converging beams to be positioned so as to minimize shadowing due to the twisted rotor blades. This ability to position the bisector of the input laser beams in an off-radial direction also allows, at least in principle, the measurement of the radial component of velocity. Fluorescent seed particles coupled with an orange-pass optical filter in the receiving optics reduce detection of unwanted scattered light. This allows measurements near the rotor hub and casing window.

Figure 2 is a simplified block diagram of the complete laser anemometer system. Velocity measurements occur randomly along the measured circumferential path since a measurement depends upon a seed particle passing through the probe volume when it is in the field of view of the optics. At any given time, the system accepts measurements from any of 1000 sequential angular positions along this circumferential path. The position information for each velocity measurement is provided by an electronic shaft angle encoder that was developed for this system. When a measurement is obtained, the transit

time and rotor position are recorded and processed by the minicomputer. In this way, velocity measurements are accumulated along a circumferential path. In this paper, velocity measurements along a circumferential path covering up to twenty blade passages is called a velocity profile. A complete velocity map is obtained by determining velocity profiles at a sequence of axial and radial positions. After each profile is obtained, the data are stored on a magnetic disk.

Overall control of the anemometer is maintained through a CRT (i.e., video) terminal. During each data run, a CRT display of the accumulated data is updated as often as every 5 seconds. The display contains: (1) alphanumeric information on operating conditions, (2) a plot of the velocity profile for an ensemble-averaged blade passage, and (3) a histogram showing the distribution of measurements over the 1000 angular positions.

Optics

The anemometer uses the 514.5 nm line of an argon ion laser operating in the TEM₀₀ mode at a power level of 1.5 watts. The laser beam (See Fig. 1) is turned through 180° before passing through two mode matching lenses. The function of these lenses is to ensure that a beam waist is located at the probe volume and that the waist diameter is the desired value, in this case, 125 μm, based on the 1/e² intensity points. Using two lenses, instead of one, allows this to be accomplished with off-the-shelf lenses (8).

The optical path through the beam splitter is shown in Fig. 3. The splitter is rotated about the optical axis to select a particular velocity component. The two optical flats are selectively coated to minimize losses. This particular splitter configuration yields equal path lengths for the two beams and symmetrical placement of the two beams about the optical axis. The splitter flats are coated for "S" polarization which means that the electric vector of the incident laser beam must be perpendicular to the plane of incidence, that is, the plane containing the surface normal and the incident beam. A λ/2 retardation plate, placed in front of the splitter, rotates the normally vertical polarization of the laser beam to follow the splitter rotation. However, a characteristic of the λ/2 retardation plate is that it rotates the direction of polarization twice the angle through which it turns. So, the retardation plate is rotated at half the angle of the beam splitter.

After passing through the 50 mm diameter, 200 mm focal length focusing lens, the two beams are turned 90° by a mirror mounted on a motorized goniometer cradle. The angle θ between the two converging beams was determined to be 2.825° by projecting the beams on a wall at a distance of about 3 m and measuring the distance to the wall and the separation of the projected spots. Because the spots were blurred, multiple measurements of the spot separation were made with the beam splitter set at different angles. The resulting standard deviation in θ from these measurements was 0.02°. With this angle θ and a wavelength of 514.5 nm, the fringe spacing is 10.4 μm.

Some of the light scattered from seed particles passing through the probe volume is collected and directed to a 100 μm diameter pinhole in front of the photomultiplier (PM) tube. The focusing lens in front of the PM tube is 50 mm in diameter, with a focal length of 160 mm. The combination of the 160 mm and 200 mm focal lengths of the two focusing lenses yields a pinhole image diameter of 125 μm at the probe volume. These lenses are commercially-available cemented doublets corrected to obtain negligible spherical aberration (to third order) for an

object-to-image ratio of infinity. A 25 mm diameter mask over the central part of the 160 mm lens is used to reduce the effective length of the probe volume to about 2 mm.

All of the optics, including the laser, are located on a large horizontal x-y traversing table. With this table, the probe volume can be located at a particular axial and radial position within 0.05 mm. The beam splitter can be rotated to within 0.03° and the direction of the input beams (i.e., the bisector of the two beams) can be oriented to within 0.01° using the goniometer-mounted mirror.

System Computers and Electronics

In order to obtain efficient operation, a minicomputer is used to process the enormous amount of data generated and to provide the required system control. The minicomputer, a 16-bit-word computer, has 32 k (k = 1024) words of core memory and hardware floating-point multiply/divide capability. These features allow large tables of data to be stored and processed quickly. It also has dual cartridge-type magnetic disk storage, with each disk having a capacity of 1.25 million 16-bit words. The minicomputer terminal has a CRT display for presentation of both alphanumeric and graphic information. Also, the minicomputer is connected by phone lines to a large central computer, to which data are transmitted for both further processing and curve plotting.

A commercial counter-type LA processor with a 500 MHz clock processes the signal bursts from the PM tube. The processor measures the transit time of a seed particle across 8 fringes. It performs several tests on each signal burst from a seed particle passing through the probe volume to help ensure measurement validity. One of these tests is the 5/8 comparison test where the transit times for 5 and 8 fringes are compared. The ratio of these two times must be sufficiently close to the value 5/8 to be accepted. Another test is a sequence check such that during each signal burst, the signal must alternately rise above a threshold level and fall below the zero level at each fringe in order to be accepted.

For each validated measurement, the LA processor loads a digital representation of the transit time for the eight fringes into an output buffer register. Also, the electronic shaft angle encoder (to be described in the next section) is signaled and the current rotor angular position is loaded into the encoder output buffer register. The processor also interrupts the minicomputer which then records the transit time and the angular position. For the particular application described in this paper, measurement rates within a circumferential path being mapped were about 2500 measurements per sec, and transit times were of the order of 50 nsec per fringe across the fringe spacing of 10.4 μm.

In keeping with the design goal of efficient data taking, the motions required to position the probe volume and select the velocity component are controlled by the minicomputer. High-speed stepping motors provide the following four motions: the axial and the radial probe volume position (x-y traversing table), the beam splitter angle, and the input beam direction (goniometer cradle). An optical encoder attached to each motor shaft provides position feedback to each motor drive. The motor drives are of the accelerate-decelerate type (with regard to the output pulse train) and typically position the optics in about one second. Each motor has a "home" position to which it can be moved for remote position calibration.

An 8-bit-word microcomputer serves as the interface between the four motor drives and the minicomputer. The microcomputer and the motor drives are

located in the test cell and the minicomputer is located in a control room. In order to minimize noise pickup in transmitting data back and forth between these two computers, a standard 20 mA asynchronous current loop is used.

Electronic Shaft Angle Encoder

This section describes the previously mentioned electronic shaft angle encoder. It was developed for the anemometer to simplify the task of tagging each velocity measurement with the proper angular position. The encoder that was developed is shown in Fig. 4. It produces the current angular position independent of rotor speed with the only required input being an accurate once-per-rev (OPR) pulse. Although the encoder involves the use of the minicomputer, a commercial stand-alone version is now available with the required computational logic circuits included. At this point, it should be mentioned that the encoder has applications beyond the anemometer described in this paper. Any application requiring the knowledge of the instantaneous angular position of a high-speed rotor could make use of the encoder. The encoded angular position of the rotor is produced by the counter that is clocked by the frequency synthesizer. The synthesizer frequency is adjusted as necessary by the minicomputer so that the number of counts for each revolution (selected by the operator) remains constant. An optical sensor, detecting a target on the rotor hub, provides the OPR pulse. At this pulse, the current count is read into the output buffer register of the counter, the counter is reset to zero, and the minicomputer is interrupted. The minicomputer then calculates a new synthesizer frequency using the equation:

$$f_n = f_{n-1} \times \frac{C_D}{C_A}$$

where f_n = new frequency, f_{n-1} = frequency programmed on previous revolution, C_D = desired count for one revolution, and C_A = actual count for previous revolution. The synthesizer is then programmed with the new frequency. Thus, the number of counts for each revolution remains approximately constant, independent of rotor speed. At each velocity measurement, a request signal causes the current count to be transferred to the output buffer register where it can be recorded with the velocity.

An operational requirement of the angle encoder is that the fractional change in the angular velocity of the rotor for each revolution be small compared to the desired resolution in the angular position expressed as a fractional part of one revolution. Otherwise, it will be necessary to adjust the synthesizer frequency more than once during each revolution. This requirement was easily met in the research facility to which the anemometer was applied. For example, the 52-bladed research rotor was operated at speeds up to about 16 000 rpm. The desired count was chosen to be 200 counts per blade passage for a total count per revolution of 10 400. The long term (i.e., 1 sec) speed drift in the facility was about 0.3 percent (30 counts out of 10 400), but the rev-to-rev speed changes were less than one count. For all results and examples cited in this paper, the encoder count was divided by four to yield a resolution of 50 angular positions (angles) per blade passage. However, the anemometer was set up so that it could operate with either 50, 100, or 200 angles per blade passage.

DESCRIPTION OF SYSTEM SOFTWARE

General Comments

Increasingly, as instruments are being applied to more difficult and/or complex experiments, computers and their associated software are assuming a larger proportion of the development time. In the anemometer being described, more than half of the development time was spent on the software. Among the software design goals was the use of a high level language (e.g., Fortran) in those cases where operating speed is not important.

Figure 5 shows a block diagram of the measurement program for determining velocity profiles. The upper four modules are Fortran. Because of execution-speed requirements, the lower three routines are written in assembly language. After the required parameters are initialized, and appropriate tables are cleared, the main program determines the routing to the various subroutines. The following sections describe the functions of these subroutines.

Once-Per-Rev (OPR)

There are two routines that are called for in response to a hardware interrupt signal, and the higher priority of the two is the OPR routine. Its primary function is to service the electronic shaft angle encoder. At the OPR pulse, this routine causes the current encoder count to be read, calculates the new synthesizer frequency, and then updates the synthesizer. If the current encoder count is not within some preset tolerance of the desired count, typically 0.1 percent, then the velocity data accumulated in the previous revolution are discarded. This prevents velocity data from being assigned to the wrong angular position if the encoder is not properly tracking the rotor speed. The OPR routine requires about 200 μ sec which is about 5 percent of a revolution at 16 000 rpm.

Data Acquisition

This is the other interrupt routine. Its function is to respond to the anemometer's counter-type processor. When a validated measurement has been obtained by the LA processor, a "data read" signal interrupts the minicomputer, which then reads both the transit time and the corresponding angular position (angle). If the angle is one of the 1000 angles being accepted, the data are put into one of two temporary buffers for further processing (See Fig. 6). If the angle is beyond the range of those angles being accepted, the routine is disabled until the next OPR occurrence. This allows data in the buffers to be processed for the rest of the revolution without interruption. This routine, the shortest of all the routines in execution time, requires about 40 μ sec. It essentially sets a limit on the rate at which velocity data can be accumulated.

Data Processing

This routine processes the data that have been placed in the temporary buffers. At any given time one of the buffers is being loaded with data and the other is being emptied as the data are processed. The reason for the two buffers is the following. As mentioned previously, after each revolution the total encoder count is compared with the desired count. If the count is within some preset tolerance and the buffer being emptied is empty, then the roles of the two buffers are exchanged. That is, the buffer being emptied in the previous revolution will now be the buffer being loaded with new data. This exchange is done in the OPR routine. However, if a spurious OPR pulse was detected during the previous revolution, the encoder may contain incorrect position counts.

An indication of this problem will show up in the OPR routine where the total count will not be within tolerance. In this case, the data in the buffer being loaded in the previous revolution will be discarded.

An important consideration in the use of the minicomputer was the amount of available random access memory, in this case, the core memory. Recording all transit time-angle data pairs would quickly fill the available memory. For example, 30 000 measurements would require 60 000 words of storage, but there are only about 10 000 words available for storage. Also, the data would not be in a form that could easily be converted into a real-time display. In order to reduce the amount of storage required, the approach taken in recording data is shown in Fig. 6. At each rotor angular position (i.e., angle, x), the following information is stored: (1) the number of measurements at each angle, $N(x)$, (2) the sum of the velocities, $\Sigma V(x)$, and (3) the sum of the velocities squared, $\Sigma V^2(x)$. With this information, the mean velocity and standard deviation can be calculated for every angle.

To obtain the velocity from the processor data output, a number of data processing steps are taken. The processor output is actually a time measurement (transit time) in a special floating-point format (mantissa-exponent). The transit time is first transformed into an integer representation of the velocity. Since the velocity is inversely proportional to the transit time, this step involves taking the reciprocal of the transit time. In integer form, the velocity is used in the comparison test described below. The velocity is then converted to the two-word floating-point format compatible with a real variable in Fortran. In this format, the quantities, $\Sigma V(x)$, and $\Sigma V^2(x)$ are calculated. The quantity, $N(x)$, is a one-word integer. The data table, thus, consists of five 16-bit words, $N(x)$, $\Sigma V(x)$, and $\Sigma V^2(x)$, for each angle. For 1000 angles, the data table takes up 5000 words of storage. The magnitude of the angle defines the location of the five words within the table.

A data run, consisting of two parts, is completed for each probe volume position and beam orientation. This enables an additional method for discarding "bad data". In the first part of the data run, velocity data from corresponding positions from all twenty blade passages are combined to form an "average" for each position (a total of 50 averages). As discussed in the next section these averages are used in the real-time display. In the second part of the data run, each measured velocity value is compared with the corresponding previously obtained average. If the difference is more than 25 percent, then that value is rejected as being "bad data".

The data processing routine continues between interrupts until (1) the desired number of measurements has been obtained, or (2) it is time for a display update. In either case, control returns to the main program. If the desired number of measurements has been obtained, a routine is called that transfers the data table to a magnetic disk.

Display Update

In order to be able to evaluate data being accumulated, a routine to provide a real time graphic display on the CRT was developed. An example of this display is shown in Fig. 7. The display is normally updated every 15 seconds, but the time between updates can be set to any value greater than 5 seconds. The display consists of three parts. The upper part is an alphanumeric presentation of some of the operating conditions. For example, it includes

the elapsed time (in seconds) since the beginning of a data run to obtain a velocity profile.

The lower part is a histogram of the number of measurements over the 1000 angles covering the twenty blade passages. The abscissa ranges from 0 to 1000 and the ordinate ($N(x)$, listed on the right side of the histogram) ranges from 0 to 80 measurements.

The middle part is a plot of the velocity profile over an ensemble-averaged blade passage. The abscissa ranges over a circumferential segment with a length of one blade pitch. Note that the abscissa for the velocity profile covers only one blade passage, while the abscissa for the histogram covers twenty blade passages. The ordinate (listed on the left side) is in feet per second. It is obtained by averaging velocity data from corresponding positions from each of the twenty blade passages.

When a CRT update is required, data acquisition is suspended for about one second while the necessary graphic information is calculated. The transmission of the graphic information to the CRT terminal is interspersed with the data processing routine, so the three-second time for transmission has a small impact on the overall measurement rate.

Optics Position Control

When the optics needs to be reset, the minicomputer transmits a set of new motor positions to the microcomputer then calculates the direction and number of pulses each motor must receive to reach the new position. The correct pulse trains are then transmitted in parallel to the corresponding motor drives. If the number of pulses transmitted to each motor agrees with number of pulses returned by the encoder on each motor shaft, the optics are assumed to be at position and ready for measurements. The microcomputer then transmits an "at position" signal to the minicomputer and measurements resume. If the numbers don't agree, an error message is transmitted to the minicomputer and appropriate action taken. The software for the minicomputer for this operation is written in Fortran, except where assembly language is required in the transmission of data. The software for the microcomputer is written in PL/M (10) except for the transmission of pulses to the motor drives.

SYSTEM PERFORMANCE

Experimental Procedure

The initial application for the anemometer was in a single-stage transonic compressor research facility. The first test rotor had 52 blades, and inlet tip diameter of 50.8 cm, and a hub-tip radius ratio of 0.7. The 100 percent design tip speed for the rotor was 426 m/s, corresponding to a rotor speed of 16 000 rpm.

Optical access to the rotor was made along a nominally radial path through a window in the casing. The window was ordinary double-strength window glass (3 mm thick) that was contoured to match the inside wall of the casing. The contouring was accomplished by allowing the glass to sag onto a machined graphite form in a vacuum furnace. The window, which was not optically coated, had a clear aperture of 5.1 cm along a circumference and 10.2 cm in the axial direction.

When the probe volume is near a solid surface, scattered laser light from the surface tends to dominate the collected signal. As a result, measurements cannot be made near the casing window and the rotor hub. In order to minimize this problem, the fluorescent dye technique (9) was used. In this technique, fluorescent seed particles absorb the laser light and then emit light at a different wavelength. An opti-

cal filter in the receiving optics filters out the unwanted laser light scattered from surfaces near the probe volume. The selected seed material was a 0.02 molar solution of rhodamine 6G in a 50-50 mixture (by volume) of ethylene glycol and benzyl alcohol. This particular material fluoresces orange when it absorbs the green laser light. Thus, when the orange-pass filter is placed in the receiving optics, the extraneous green scattered light is filtered out. A commercial atomizer produced the seed particle aerosol by feeding the liquid into a high velocity jet (located within the atomizer). The mean size of the particles that were actually measured was estimated to be about 2 to 1.4 μ m. This estimate is based on (1) particle lag in crossing shocks within the rotor, and (2) separate experiments involving particle acceleration through a nozzle with known flow conditions.

Results

Velocity measurements were taken over operating conditions ranging from 50 to 100 percent design speed. A detailed description and discussion of the results are given elsewhere (7). However, sufficient description is given here to illustrate the capabilities of the anemometer.

The encoder worked very well in providing the rotor angular position information. For example, at 16 000 rpm the average deviation of the actual encoder count from the desired count for a complete revolution was about 3 counts out of 10 400 (200x52 blades). Remembering that each rotor angular position is obtained by dividing the encoder count by four, the average error in the angular position was 0.75 at the end of a revolution. As the rotor speed drifts up and down, the position error generally is a minimum at the beginning of a revolution when the synthesizer update occurs and a maximum at the end. The 20 blade passages selected for measurements were normally in the first half of each revolution. Thus, the actual average error in the rotor angular position was less than 0.75 out of 50 for each of the twenty blade passages.

Velocity profiles along circumferential paths covering 20 consecutive blade passages (i.e., 50 angular positions per blade passage X 20 blade passages) were determined and recorded. Axial and radial positions that were measured included the region upstream and downstream of the rotor as well as within the blade row. Typically, the profiles consisting of 30 000 measurements over 1000 angular positions were obtained in 15 to 45 seconds. At 90 to 100 percent design speeds, shocks were measured in front of and within the blade row.

The real-time display shown in Fig. 7 is a typical result and was obtained at 90 percent design speed (14 510 rpm) within the blade row. It shows the ensemble-averaged velocity profile for one blade passage at 20 seconds into the second part of a data run where 13 846 out of 30 000 measurements have been obtained. The "DATA RATE" of 626 per sec is only an approximate value since the time of 20 seconds is only an approximate value. The "LDV FREQ" of 20.096 MHz is a typical value of the LA frequency calculated from the LA processor output. A total of 593 measurements have been rejected because they differed by more than 25 percent from the corresponding average obtained in the first part of the data run. The "COUNTS PER REV" of 10 399 is a typical value of the encoder count for one rotor revolution. In this case, the desired count was 10 400. The "# BAD REVS" is the number of revolutions since the beginning of part two of the data run where the total encoder count for one revolution differed from the desired count by more than the preset tolerance (in

this case, 10). The "NO. IN MT BUFFER" is the number of transit time-angle data pairs in the temporary data buffer being processed. If this number becomes large, it indicates the minicomputer is not keeping up with the data being collected. The knee of the profile is where a shock occurs. The gap at the right is where the blade for the ensemble-averaged blade passage occurs. The gaps in the histogram at the bottom are where the 20 individual blades occur. At the edge of the eighth gap from the left there is a spike in the number of measurements. This is probably caused by this particular blade becoming coated with the fluorescent dye material.

The accuracy of measurements made with a fringe-type anemometer is strongly dependent on each application. Pertinent factors include the flow conditions, signal-to-noise ratio of each signal burst, system noise, etc. In this particular application, it is estimated that the velocity profiles determined for the ensemble-averaged blade passage are accurate to within about 3 to 5 percent.

CONCLUSIONS

This paper has described an anemometer that was designed to make intra-rotor flow measurements in turbomachinery rapidly and efficiently. Another design goal was to maximize the size of the intra-rotor region that is mapped. The application of the anemometer to a transonic axial compressor rotor demonstrated that these goals were met. Detailed measurements of shocks and intra-rotor flow velocities have been obtained. The scheme whereby velocities are accepted from many different angular positions at any given time works very well. Velocity profiles along a circumferential path covering up to 20 blade passages can be determined, typically, in about 30 seconds. An added benefit of this scheme is the high spatial resolution along the resulting velocity profile.

The real-time display developed for the anemometer is helpful in achieving efficient operation. As an example, both the ensemble-averaged velocity profile and the histogram are useful indicators of extraneous velocity data due to light scattering by the rotating blades. When this problem is significant, corrective action can be taken (e.g., input laser beam direction can be changed).

The capability of changing the input laser beam direction allows an increase in the size of the intra-rotor region mapped. By operating at a calculated optimum input direction, the shadowing due to twisted rotor blades is minimized.

REFERENCES

1. Durst, F., Melling, A., and Whitelaw, J. H., Principles and Practice of Laser Doppler Anemometry, Academic Press, New York, 1976.
2. Wisler, D. C. and Mossey, P. W., "Gas Velocity Measurements Within a Compressor Rotor Passage Using the Laser Doppler Velocimeter," JOURNAL OF ENGINEERING FOR POWER, Vol. 95, No. 2, Apr. 1973, pp. 91-96. (ASME Paper 72-WA/GT-2, Nov. 1972.)
3. Wisler, D. C., "Shock Wave and Flow Velocity Measurements in a High Speed Fan Rotor Using the Laser Velocimeter," JOURNAL OF ENGINEERING FOR POWER, Vol. 99, No. 2, Apr. 1977, pp. 181-188. (ASME Paper 76-GT-49, Mar. 1976.)
4. Schodl, R., "Laser Dual-Beam Method for Flow Measurements in Turbomachines," ASME Paper 74-GT-157, Mar. 1974.

5. Eckardt, D., "Detailed Flow Investigations Within a High-Speed Centrifugal Compressor Impeller," JOURNAL OF FLUIDS ENGINEERING, Vol. 98, No. 3, Sept. 1976, pp. 390-402. (ASME Paper 76-F-13, Mar. 1976.)

6. Dunker, R. J., Strinning, P. E., and Weyer, H. B., "Experimental Study of the Flow Field Within a Transonic Axial Compressor Rotor by Laser Velocimetry and Comparison with Through-Flow Calculations," JOURNAL OF ENGINEERING FOR POWER, Vol. 100, No. 2, Apr. 1978, pp. 279-286. (ASME Paper 77-GT-28, Mar. 1977.)

7. Streisler, A. J. and Powell, J. A., "Laser Anemometer Measurements in a Transonic Axial Flow Compressor Rotor," To be Presented at the Symposium on Measurement Methods in Rotating Components of Turbomachinery, Gas Turbine Conference and Products Show, New Orleans, Mar. 9-13, 1980.

8. Seasholtz, R. G., "Laser Doppler Velocimeter System for Turbine Stator Cascade Studies and Analysis of Statistical Biasing Errors," NASA TN D-8297, 1977.

9. Stevenson, W. H., dos Santos, R., and Mettler, S. C., "Fringe Mode Fluorescence Velocimetry," AGARD CP-193, 1976, pp. 20-1 to 20-9.

10. "8008 and 8080 PL/M Programming Manual," Intel Corporation, Santa Clara, Calif., 1975.

REPRODUCTION OF THIS
ORIGINAL PAGE IS POOR

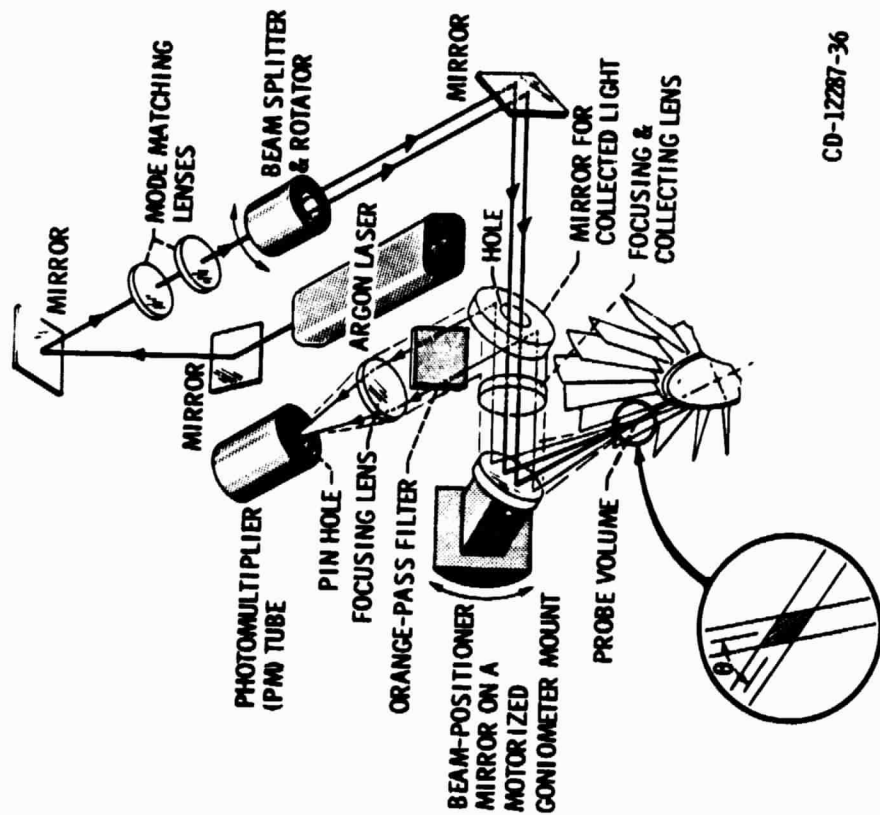

Figure 1 - Optical layout of anemometer.

CD-12287-36

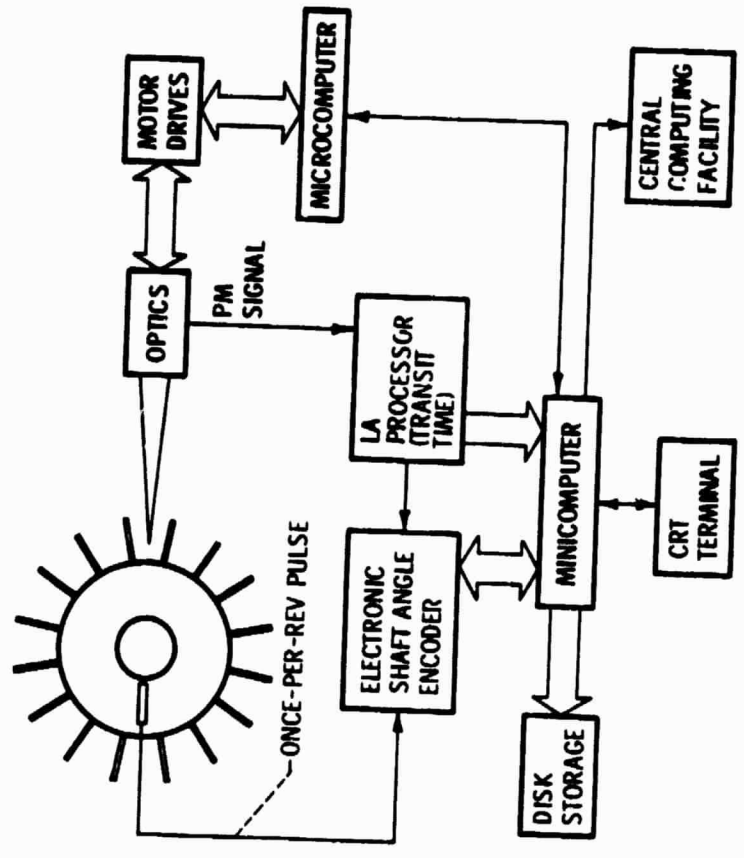

Figure 2 - Block diagram of complete anemometer.

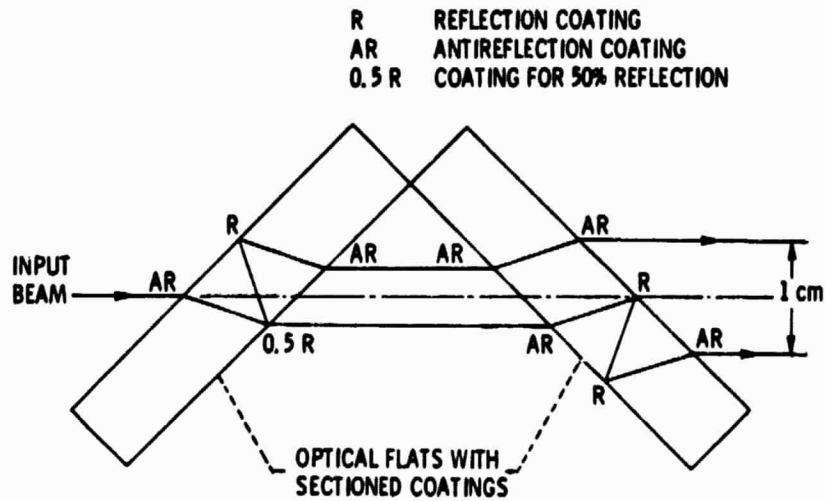

Figure 3. - Optical path through beam splitter.

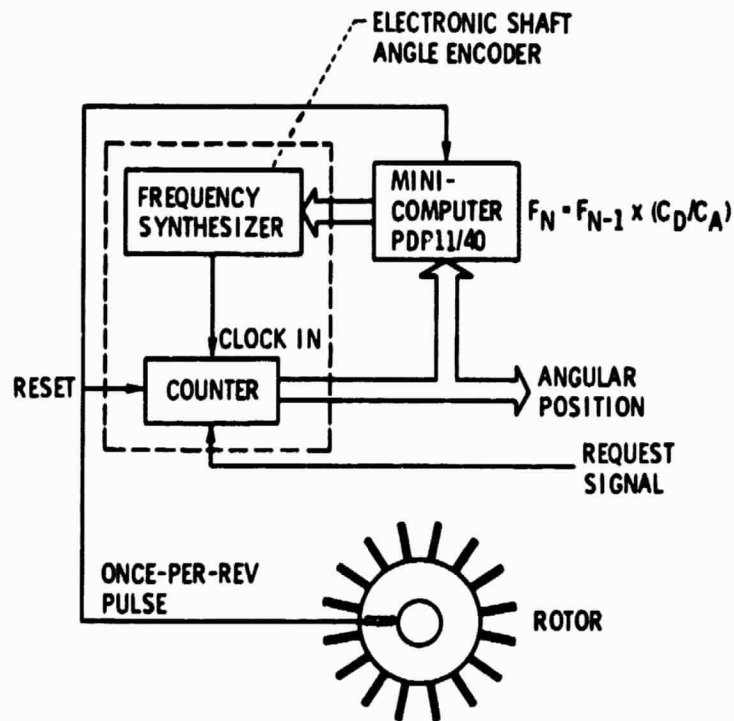

Figure 4. - Method for generating the rotor angular position.

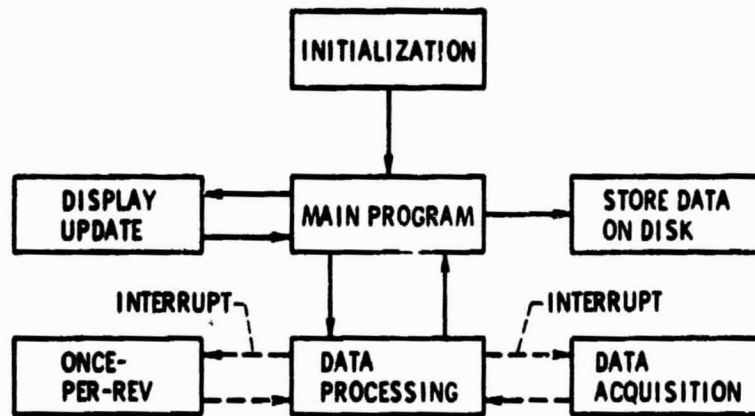
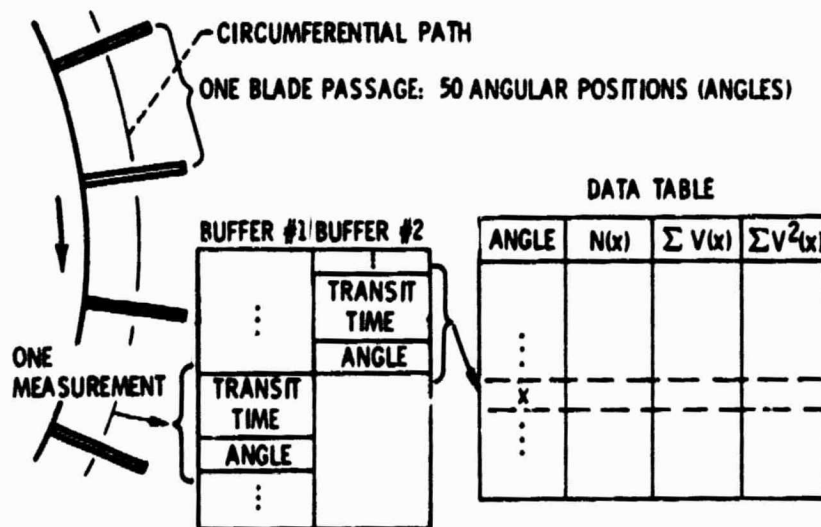

Figure 5. - Diagram of the minicomputer routines used in the anemometer measurement program.



$N(x)$ - NUMBER OF MEASUREMENTS AT ANGLE x
 $V(x)$ - ONE VELOCITY AT ANGLE x

$$\text{VELOCITY} = \frac{\text{FRINGE SPACING}}{\text{TRANSIT TIME (ONE FRINGE)}}$$

TYPICAL DATA RUN:
 30 000 MEASUREMENTS OVER
 1000 ANGLES

Figure 6. - Data acquisition and processing scheme.

RUN NO. 17708
ROTOR RPM: 14613
COUNTS/REV: 16300

CLIPPED TIME: 20
0 AND REVS: 0
NO. IN MT BUFFER: 0

NO. OF MEASUREMENTS: 13046/30000
DATA RATE: 628
LOW FREQ: 20.0000
NO. OF HEAD. REJ.: 503

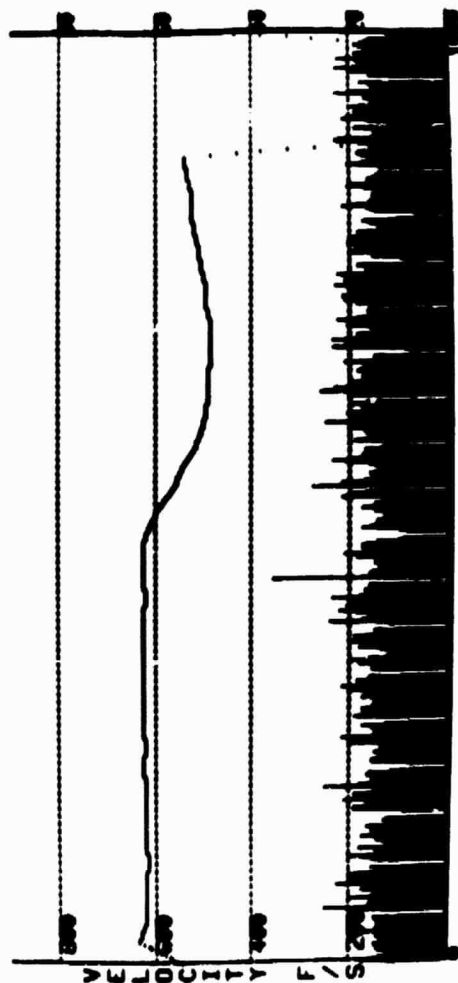

Figure 7. - CRT real-time presentation of accumulated data.