

NASA Contractor Report CR-158926-1

Hypersonic Cruise Aircraft Propulsion Integration Study Volume I

R. E. Morris

G. D. Brewer

LOCKHEED-CALIFORNIA COMPANY
BURBANK, CALIFORNIA

CONTRACT NAS1-15057
September 1979

NASA

National Aeronautics and
Space Administration

Langley Research Center
Hampton, Virginia 23665

FOREWORD

This is the final report of a study made under Contract NAS1-15057 for NASA-Langley Research Center, Hampton, Virginia.

Volume I includes the study guidelines, the candidate configuration analysis and selection, propulsion concepts, final propulsion evaluation and comparison, and the study conclusions and recommendations.

Volume II presents supporting aerodynamic, propulsion, and weight technology data as well as the selected candidates configuration analysis and refinement of the final baseline vehicle used for evaluation of the two propulsion concepts described in Volume I.

The Lockheed-California Company was the principal contractor to NASA and the work was performed in the Commercial Advanced Design Division at Burbank, California. The following individuals were the main contributors:

Daniel Brewer, Study Manager

Rober Morris, Project Engineer

Jerry Rising, Aerodynamics

Marvin Baxendale, Aerodynamics

Roger Jensen, Weights

Chris Monoleos, Aircraft Synthesis

Mr. Joe Watts of the Hypersonic Aerodynamics Branch of NASA - Langley served as Technical Monitor.

TABLE OF CONTENTS

	Page
FOREWORD.	i
LIST OF FIGURES	iv
LIST OF TABLES.	v
SUMMARY	1
SYMBOLS	4
1. INTRODUCTION.	7
2. STUDY GUIDELINES.	8
3. TECHNICAL APPROACH.	9
3.1 Candidate Configuration Analysis and Selection	9
3.1.1 Data acquisition and review	9
3.1.2 Aircraft configuration conceptualization.	9
3.1.3 Configuration screening	11
3.1.4 Vehicle synthesis	11
3.1.5 Candidate configurations.	13
3.1.6 Evaluation of selected candidates	20
3.2 Configuration Refinement	20
3.3 Propulsion Concepts.	33
3.3.1 Separate inlet, turbojet-scramjet system.	33
3.3.2 Common variable-geometry, turbojet-ramjet system.	34
4. BASIC TECHNOLOGY.	41
4.1 Aerodynamics	41
4.2 Aircraft Weight Estimation	41
4.3 Initial Propulsion Data.	42
4.4 Final Propulsion Evaluation.	42
5. COMPARATIVE ANALYSIS OF PROPULSION SYSTEMS.	42
5.1 Separate Inlet, Turbojet-Scramjet System	43
5.1.1 Weight sensitivity.	43
5.1.2 Fuel sensitivity.	43
5.1.3 Range sensitivity	47
5.1.4 Subsonic cruise range	47
5.2 Common Variable-Geometry, Turbojet-Ramjet System	48
5.3 Comparison of Separate Inlet & Common Inlet Systems.	56

TABLE OF CONTENTS (Continued)

	Page
5.4 Turbojet-Ramjet System With Fixed Diverter.	58
6. STUDY CONCLUSIONS.	65
6.1 Installation Drag	65
6.2 Thrust Available, Mach 3.5 to 5	70
6.3 System Weight Comparison.	70
7. STUDY RECOMMENDATIONS.	74
REFERENCES	75

LIST OF FIGURES

Figure		Page
1	Work Plan, hypersonic cruise aircraft propulsion integration study.	10
2	ASSET vehicle synthesis program schematic.	12
3	HYCAT-1 general arrangement.	15
4	HYCAT-2 general arrangement.	17
5	HYCAT-2 cabin arrangement.	14
6	HYCAT-2 cabin cross section.	19
7	HYCAT-3 general arrangement.	21
8	HYCAT-4 general arrangement.	23
9	HYCAT-4 propulsion installation.	25
10	HYCAT-5 general arrangement.	27
11	General arrangement, baseline version of HYCAT-1A.	35
12	Separate inlet, turbojet-scrumjet system schematic	37
13	Common variable geometry inlet, turbojet-ramjet system schematic :	39
14	HYCAT-1A, final general arrangement	45
15	Mission climb history, turbojet-scrumjet system	60
16	Mission climb history, turbojet-ramjet system	61
17	Installed thrust coefficient, ramjet with fixed diverter	62
18	Installed specific impulse, ramjet with fixed diverter	63
19	Cruise part power performance, ramjet with fixed diverter	64
20	Installation drag comparison, TJ-RJ and TJ-SJ systems	68
21	Inlet mass flow comparison, TJ-RJ and TJ-SJ systems	69
22	Performance comparison, Mach 3.5 to 5; TJ-RJ and TH-SJ Systems	71

LIST OF TABLES

Table		Page
1	Candidate Configuration Comparison.	29
2	Comparison of Optimized HYCAT-1 and -4.	31
3	Configuration Problem Areas	32
4	HYCAT-1A Point Design Characteristics	44
5	Unit Structural Weights, HYCAT-1A	47
6a	Point Design Characteristics of HYCAT-1A at Ranges of 7408, 8334 and 9260 km (S.I Units).	48
6b	Point Design Characteristics of HYCAT-1A at Ranges of 4000, 4500 and 5000 n.mi. (Customary Units)	49
7a	Weight Build-Up Comparison of Turbojet-Ramjet System Installed in Turbojet-Scramjet Point Design Aircraft (S.I Units).	50
7b	Weight Build-Up Comparison of Turbojet-Ramjet System Installed in Turbojet-Scramjet Point Design Aircraft (Customary Units).	51
8a	Comparison of Mission Fuel Consumption of Turbojet-Ramjet System Installed in Point Design Turbojet-Scramjet Aircraft (S.I Units)	52
8b	Comparison of Mission Fuel Consumption of Turbojet-Ramjet System Installed in Point Design Turbojet-Scramjet Aircraft (Customary Units)	55
9a	Baseline Aircraft Cruise Comparison of the Turbojet-Ramjet and the Turbojet-Scramjet System (S.I. Units)	54
9b	Baseline Aircraft Cruise Comparison of the Turbojet-Ramjet and the Turbojet-Scramjet System (Customary Units).	55
10	HYCAT-1A Point Design Characteristics	57
11	Weight Fraction Comparison - Point Design, Scramjet and Ramjet Systems.	59
12a	Aircraft Weight Comparison of Turbojet - Ramjet System with Retractable and Fixed Diverter (S.I. Units)	66
12b	Aircraft Weight Comparison of Turbojet - Ramjet System with Retractable and Fixed Diverter (Customary Units).	67
13	Propulsion Systems Weight Comparison.	72

HYPERSONIC CRUISE AIRCRAFT
PROPULSION INTEGRATION STUDY

R. E. Morris, and G. D. Brewer

Lockheed-California Company
Burbank, California

SUMMARY

This report, consisting of Volumes I and II, describes the work done by the Lockheed-California Company on the NASA Hypersonic Cruise Aircraft Propulsion Integration Study, Contract NAS1-15057. The primary emphasis was to evolve the most promising conceptual vehicle and propulsion integration approach for a liquid hydrogen fueled, Mach 6 transport capable of carrying 200 passengers 9 260 km (5 000 nm).

The work was conducted in two phases with the initial phase being a generation and screening of candidate vehicle configurations, comparative analysis of the two most promising concepts, selection and design refinement of the surviving candidate. The final phase used this selected configuration as the baseline aircraft in the comparative evaluation of two propulsion integration concepts:

- A turbojet engine with a retractable inlet used for takeoff, acceleration and landing, together with separate fixed-geometry dual-mode combustion scramjet engines for cruise (Turbojet-Scramjet System).
- A turbojet engine with a separate variable-throat subsonic combustion ramjet engine with both engines obtaining air from a common variable-geometry inlet (Turbojet-Ramjet System).

Other trade studies included the effect on aircraft gross weight of such variables as wing geometry, field length, approach speed, range, propulsion installation drag, gross thrust vector angle, range capability during all subsonic cruise and growth sensitivity.

The major conclusions drawn from the initial or vehicle configuration selection and refinement phase are:

- The gross weight of aircraft to perform the design mission are in the 272 160 to 362 880 kg (600 000 to 800 000 lb) class.
- The lift provided by a flattened fuselage forebody is important in improving hypersonic L/D and in providing the flow field and geometric

width necessary for the propulsion installation. This is of particular importance in hydrogen-fueled aircraft with a large potential fuselage to wing planform area ratio.

- The use of a horizontal tail in the selected configuration was required for trim purposes and provided a favorable tradeoff by allowing the use of drooped ailerons to obtain more low speed lift with the final payoff being the reduction of wing size and weight. A further benefit is the reduction of the neutral point variation with Mach number.
 - The most critical design criterion is to meet the landing field length constraint without increasing the wing aspect ratio or reducing the wing loading, both of which options result in increased gross weights.
- The propulsion system should be integrated with the fuselage to avoid excessive wave and friction drag. It should also be located far enough forward for balance purposes and to allow for takeoff rotation without requiring a long main gear for clearance. Further benefits are the reduction of propulsion moments when the system is located near the center of gravity, and a reduction in the boundary layer displacement thickness. Adverse effects of the fuselage boundary layer could dictate the use of wing-mounted propulsion nacelles.
- The location and optimum inclination of the gross thrust vector can make a significant reduction in cruise fuel flow by reducing the aerodynamic lift required and consequently the drag.
 - Based on supersonic transport design experience and the high growth sensitivity of the hypersonic transport, the imposition of airport noise constraints would have a very adverse impact on vehicle size although it is possible that this could be mitigated to some extent by a variable cycle accelerator engine in which, as a secondary benefit, the subsonic SFC could be improved thereby reducing the reserve fuel consumption.

The results of the final propulsion integration study phase indicate that to perform the design mission, the vehicle using the turbojet-scrumjet system would require a gross weight of approximately 351 000 kg (774 006 lb) compared to 278 000 kg (613 000 lb) for the turbojet-ramjet propulsion system. In each case the aircraft was optimized with respect to wing loading, thrust to weight and capture area or cowl size while meeting the critical performance constraints. Both aircraft flew the same mission and had the same reserve fuel requirement in subsonic flight. The major conclusion from this phase is that the difference in gross weights are due, not to the engine combustion mode (subsonic vs supersonic), but to the following:

- The reduction in both mission fuel consumption and installed propulsion weight made possible by the use of a common variable geometry

inlet for both the turbojet and ramjet engines. The reduction in spillage drag of the common inlet in the critical transonic region allows a smaller cowl size and reduced fuel consumption both in acceleration and subsonic cruise.

- The use of this variable geometry inlet increased the inlet air flow (and thrust) in the critical Mach 3.5 to 5 region after turbojet shutdown.

The net result is that the turbojet-scrumjet system is penalized in both fuel consumption and installed weight caused by high subsonic/transonic spillage drag and by low thrust in the Mach 3.5 to 5 region due to a lower mass flow resulting from the fixed geometry scrumjet engine.

The primary recommendation, considering the propulsion application to a transport mission, is to pursue the use of a common inlet for the acceleration and cruise engines and to provide a higher thrust level in the Mach 3 to 5 region by variable geometry or other means.

The majority of the remaining recommendations were the result of uncertainties in the prediction methods used in the study. Testing and analytical correlation is required in the following areas:

- Demonstrate that either the variable or fixed geometry engines (inlet + combustor + nozzle) could operate efficiently while ingesting the boundary layer from the long fuselage forebody.
- If a diverter is required for either system what is the low speed drag and what lift contribution is caused by the shock field impingement on the fuselage or wing underside?
- Determine by test the spillage lift and drag forces in the transonic region.
- Simulate propulsion flows to determine base drags and moments.
- Further work is required to define the comparative weights and cooling requirements of both propulsion systems.

SYMBOLS

		SI Units	Customary Units
A	area	m^2	ft^2
A_∞, A_0, A_1	flow field streamtube areas	m^2	ft^2
A_2	minimum inlet area	m^2	ft^2
A_3	ramjet inlet area	m^2	ft^2
A_6	geometric exit area	m^2	ft^2
A_c	inlet geometric capture area	m^2	ft^2
A_{ex}	exhaust flow area	m^2	ft^2
APU	auxiliary power unit	-	-
AR	aspect ratio	-	-
ASSET	Advanced Systems Synthesis and Evaluation Technique - Lockheed computer program	-	-
c	chord	m	ft
\bar{c}	mean aerodynamic chord	m	ft
C_D	drag coefficient	-	-
D	drag	kg	lb
FAR	Federal Aviation Regulation	-	-
F_N	net installed thrust	N	lb
F_{NJ}	net uninstalled thrust	N	lb
F_{Ns1s}	net sea level static thrust	N	lb
HYCAT	Hypersonic Cruise Aircraft Technology	-	-
IOC	initial operational capability	-	-
ISP	specific impulse	Ns/kg	sec
Keas	knots equivalent airspeed	m/s	kts

		SI Units	Customary Units
L	length, aerodynamic lift	-	-
LE	leading edge	-	-
L/D	lift to drag ratio	-	-
LH ₂	liquid hydrogen	-	-
M	mach number	-	-
MAC	mean aerodynamic chord	m	ft
M _∞	free stream mach number	-	-
M ₀ , M ₁ , M ₂	flow field local mach numbers	-	-
OEW	operating empty weight	kg	lb
P	static pressure	Pa	lb/in ²
P _T	total pressure	Pa	lb/in ²
q	dynamic pressure	Pa	lb/ft ²
RJ	ramjet		
S, S _{REF}	wing reference area	m ²	ft ²
SFC	specific fuel consumption	kg/hr/daN	lbm/hr/lb
SJ	scramjet (supersonic combustion scramjet)	-	-
SLS, sls	sea level static		
T/C, t/c	wing thickness ratio	-	-
TJ	turbojet	-	-
T/W, F _{SLS} /W	sea level static thrust to aircraft gross weight	4N/kg	-
W, Wg	gross weight	kg	lb
W/S	wing loading	kg/m ²	lb/ft ²
α	angle of attack	rad	deg

		<u>SI</u> <u>Units</u>	<u>Customary</u> <u>Units</u>
β	angle of gross thrust	rad	deg
ξ_0^*, δ_1^*	boundary layer displacement thickness	m	ft
Λ	sweep angle	rad	deg
ϕ	fuel-air equivalence ratio	-	-

1. INTRODUCTION

This is the Volume I final report of a study performed by Lockheed-California Company for the Hypersonics Branch of NASA-Langley Research Center. The primary purpose of the work was to evolve the most satisfactory conceptual vehicle configuration and propulsion integration approach for a Mach 6 transport aircraft capable of carrying 200 passengers 9260 km (5000 n.mi.).

Hypersonic aircraft of the future will require propulsion systems which operate in two modes; one mode for takeoff, landing, and acceleration through the subsonic/supersonic speed regime and another mode for acceleration and cruise at Mach numbers above about 3.5. Many of the characteristics and requirements of the hypersonic cruise mode are not compatible with subsonic operation and many of the characteristics of the subsonic mode are not compatible with the hypersonic speed regime. Considerable ingenuity and effort will be required to achieve a total system which circumvents the potentially high off-design performance penalties of either system.

Past studies of hypersonic cruise aircraft have not dealt in depth with the subsonic and transonic performance problems of hypersonic configurations; consequently the study effort was directed at the integration of the subsonic/supersonic/hypersonic propulsion systems with the aerodynamic design of the airframe.

In the first part of the study numerous configuration design approaches were considered. Some were rejected almost immediately for obvious reasons in spite of their offering some unique advantage which led to their being suggested in the first place.

Those aircraft and propulsion configurations which appeared to be generally promising were sized and design layout drawings were made. These concepts were screened qualitatively, then selected designs were evaluated quantitatively using the Lockheed proprietary vehicle synthesis computer program, ASSET.

The results of the vehicle screening evaluation were used to select a preferred aircraft design concept for a more detailed propulsion integration concept analysis in the final effort reported in this volume.

Vol II contains supporting data including an explanation of technical methods which were used and configuration details which were significant in the evaluation of the final vehicle concept.

2. STUDY GUIDELINES

The choice of a commercial transport to represent the mission to serve as a basis for a design study of hypersonic aircraft was an arbitrary one, but to ensure consistent criteria for comparison purposes the following guidelines similar to current practice were used:

1. Design mission: 200 passengers - 9260 km (5000 n.mi.) range - Mach 6 cruise. Accommodations comparable with current supersonic transport concepts.
2. IOC date: 2000. Consistent advanced aircraft technologies were used.
3. Performance and environmental constraints consistent with practices at current large international airports. The performance at low speeds must be compatible with the airport aids and other aircraft in the airport environment. For example:
 - Speed in controlled airspace 128 m/s (250 keas) maximum
 - Minimum engine-out climb gradient ≥ 0.030
 - Maximum FAR field length = 3200m (10 500 ft)
4. LH₂ assured available at all airports.
5. Requirements of FAR 25 (airworthiness standards) to be met where applicable.
6. As a design goal, the aircraft life to be commensurate with current aircraft.
7. The primary evaluation criterion used in selecting preferred designs was minimum takeoff gross weight.
8. Design allowances and requirements for the mission included the following:
 - An allowance of 10 minutes at ground idle power provided for taxi out and taxi in.
 - One minute at maximum power provided for takeoff.
 - Maximum speed below 3048m (10 000 ft) to be 128 m/s (250 kias).
 - Six minutes air maneuver time for landing.

- Fuel reserves: 5% of block fuel plus subsonic flight at optimum altitude and speed to a 482 km (260 n.mi.) alternate airport, plus 30 minutes loiter at 4572m (15 000 ft).
- Descent to be at equilibrium glide (L/D maximum). Turbojets to be turned on at Mach .8 at flight idle power to provide hydraulic and electric power. This power is supplied by an APU when the turbojets are not running.

3. TECHNICAL APPROACH

In accordance with the objective of developing a preferred configuration for a hypersonic transport aircraft, the initial phase of the study was aimed at exploring all feasible concepts. The final phase involved a more detailed design study of propulsion concepts in a defined configuration selected as a result of the screening analysis.

3.1 Candidate Configuration Analysis and Selection

The study plan is graphically illustrated in figure 1.

3.1.1 Data acquisition and review. - In view of the basic requirement for a morphological approach to consider all feasible aircraft configurations, the first step in the process was to obtain information about previous design studies and to review the conclusions which had been reached concerning each. In addition, the latest information which could be obtained about turbojet and turbofan engines that might be used for takeoff and acceleration to Mach 3.5, and on dual-mode convertible scramjet engines that were suitable for operation from Mach 1.0 to Mach 6.0 was explored.

A study by Lockheed (reference 1) was useful in providing realistic size, weight, and design requirement information about the aircraft LH₂ fuel system and its major components.

This review of pertinent data on hypersonic vehicles propulsion and hydrogen technology was used in the generation of candidate aircraft configurations.

3.1.2 Aircraft configuration conceptualization. - As many aircraft design concepts as possible were postulated during the study. Any configuration which appeared to offer merit was considered. Innovative ideas were encouraged.

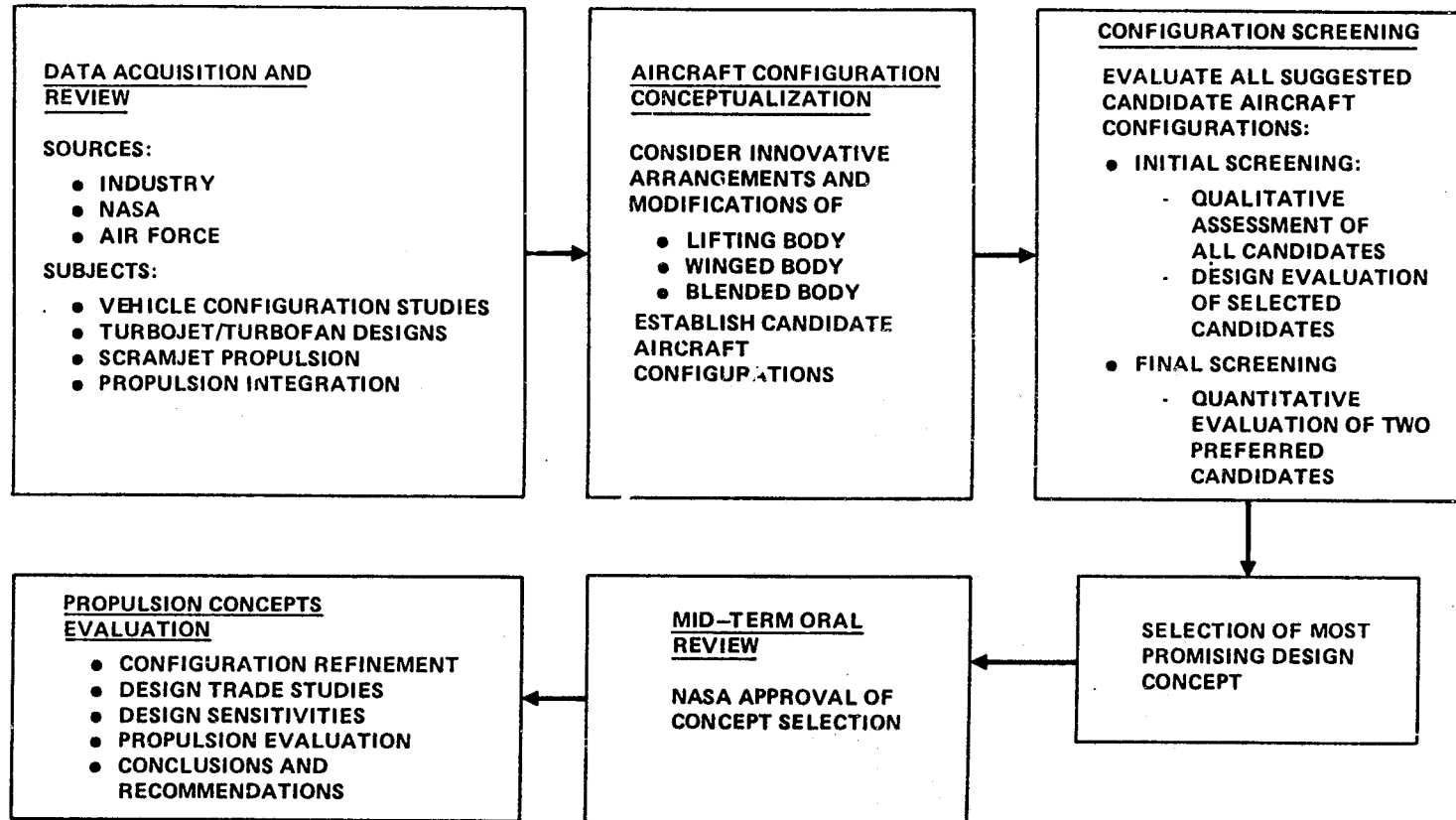

Figure 1. - Work plan, hypersonic cruise aircraft propulsion integration study.

There was no special period of time allocated for generation of vehicle configurations. New ideas for aircraft configurations, or for modifications of existing concepts, were considered throughout the study.

3.1.3 Configuration screening. - All ideas for airplane designs were considered and evaluated. There were two levels of screening; the initial level was essentially qualitative, the final was more detailed and provided quantitative data with which selected candidate designs could be compared.

The initial screening process was itself divided into two parts. All suggested design ideas were evaluated on a cursory basis to determine if there was sufficient merit in the concept to warrant further analysis. Naturally, some concepts did not survive this step. All too often the attractive feature which led to the suggested configuration was obtained at the expense of penalties incurred in other features of the design. Where it was obvious the tradeoff would be unfavorable the concept was discarded.

There was also a comparison of designs, one with another. Those design concepts which appeared most favorable on the basis of this qualitative comparison were laid out as three-view drawings in order to more vigorously assess their individual merit. In all, five candidate designs were treated in this manner. The design exercise permitted an evaluation of the practicability of the configuration, or permitted insight into the potential for making the design practical.

Such features as adequacy of room and safety for passenger accommodations, feasibility of integrating the two separate propulsion systems, potential for achieving a reasonably efficient structural design, and the possibility of maintaining the proper relationship between center of gravity and aerodynamic center of pressure throughout the flight regime as required for vehicle stability and control could all be assessed. In addition the aircraft was sized to a first approximation so that adequate fuel tankage was provided, landing gear could be located and its length determined to provide necessary tail scrape clearance, and the landing gear stowage problem conceptually resolved.

The design evaluation of the five candidate configurations led to selection of two for final screening. One of these was the HT4 vehicle shape, previously studied by NASA in wind tunnel tests. This shape was selected for two reasons; one, it appeared to be a very promising configuration (if certain modifications are made) and two, the existence of the wind tunnel data offered opportunity for verification of analytical results.

3.1.4 Vehicle synthesis. - The main tool used in the final screening and the trade studies is Lockheed's (Advanced System Synthesis Evaluation Technique (ASSET)) program. ASSET is a vehicle synthesis model designed to size, parametrically weight, evaluate the performance, and cost large numbers of aircraft design options. A schematic presentation of the primary input and output data involved in the ASSET synthesis cycle, which is programmed on a high speed digital computer, is shown on figure 2. The ASSET program output consists of a group weight statement, vehicle geometry description, mission

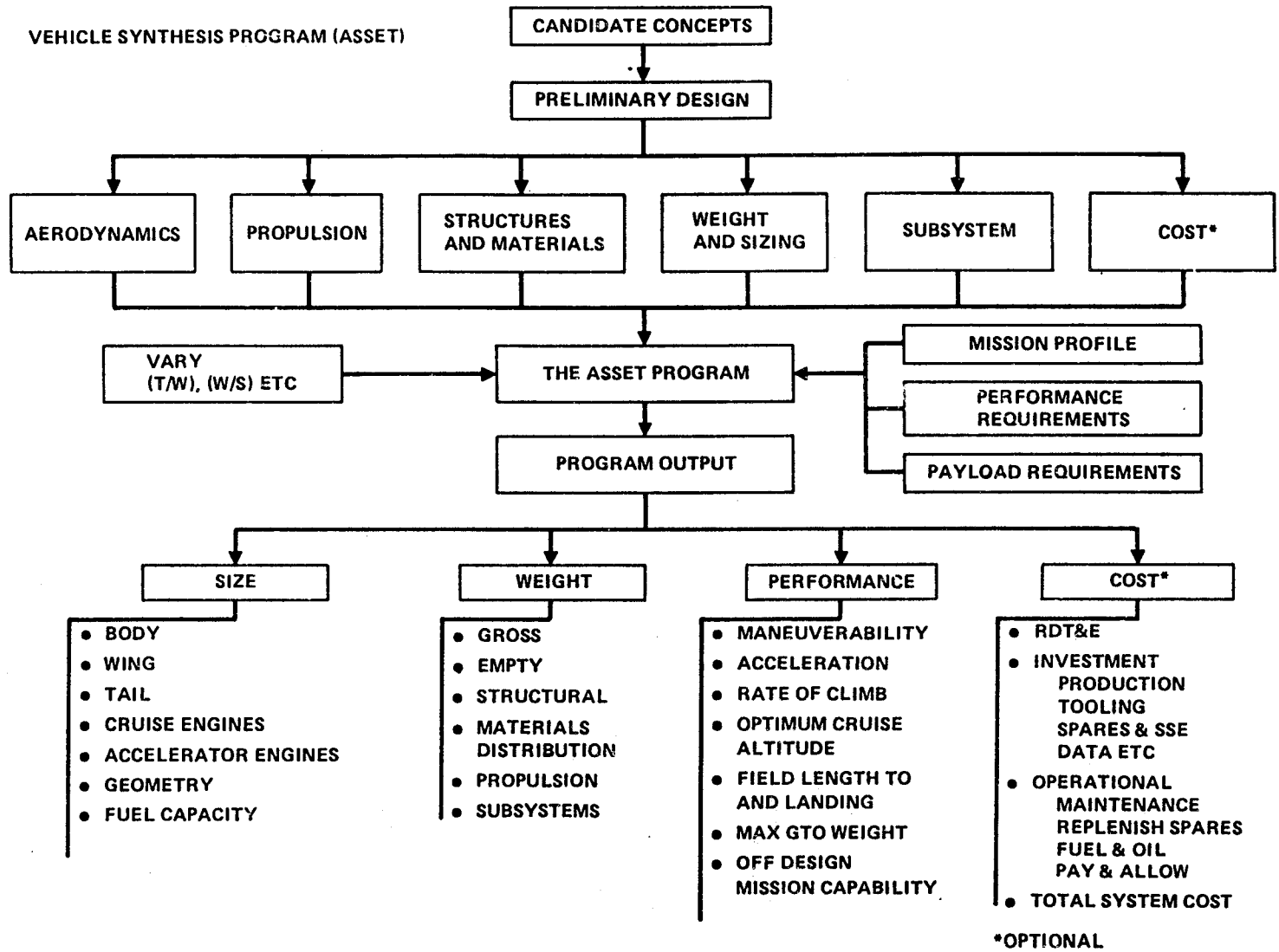

Figure 2. - ASSET vehicle synthesis program schematic.

summary profile, and a summary of the vehicle's performance evaluation. ASSET is composed of three major subprograms: vehicle sizing, performance evaluation, and costing (if desired).

Although the current ASSET program is very flexible and capable of analyzing many different types of aircraft, it was decided that significant changes should be made to more conveniently handle hypersonic aircraft because of the many propulsion forces involved and their interaction with the aerodynamic forces. A further complication is the change of these forces with angle of attack so that an iterative solution is required for each point in the mission profile.

Accordingly, a new routine was written, to be used as a supplement to the existing ASSET program, which is called Hypersonic ASSET. This work was funded as a part of Lockheed's Independent Research and Development (IRAD) program.

3.1.5 Candidate configurations. - From the matrix of conceptual designs suggested by both Langley and Lockheed personnel, five configurations were generated as candidates. These consisted of blended wing-bodies, semi-blended wing-bodies and wing-body. Both high and low wing were considered as well as various locations and arrangements of the baseline fixed geometry dual mode cruise propulsion system. These propulsion concepts have two things in common however; the use of a retracting inlet for the turbojet accelerator engine and the reduction of base drag by using a common nozzle for both the turbojet and scramjet exhaust. The retracting turbojet inlet is a major problem area in that it must have variable geometry when extended but retract into a minimum of space. Location of this inlet is also critical in that it should not interfere with the scramjet during dual mode operation and should not be in an adverse flow region in particular at low speed and high angles of attack.

The general arrangement of the various HYCAT configurations are shown in the following figures:

- Figure 3 HYCAT-1 General Arrangement
- Figure 4 HYCAT-2 General Arrangement
- Figure 5 HYCAT-2 Cabin Arrangement
- Figure 6 HYCAT-2 Cabin Cross Section
- Figure 7 HYCAT-3 General Arrangement
- Figure 8 HYCAT-4 General Arrangement
- Figure 9 HYCAT-4 Propulsion Installation
- Figure 10 HYCAT-5 General Arrangement

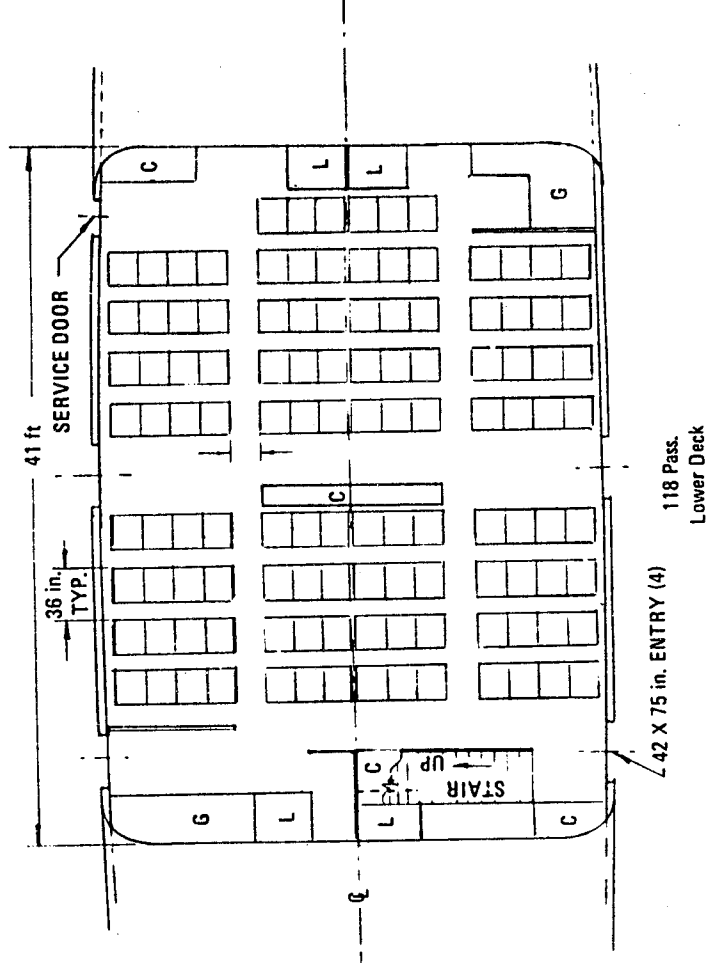
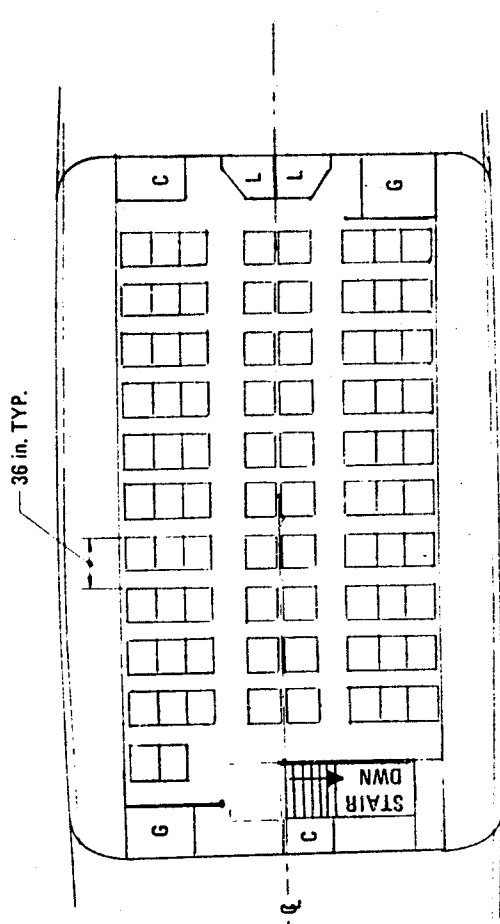

- G = Galley
- C = Closet
- L = Lavatory

Figure 5. - HYCAT-2 cabin arrangement.

	Wing	V. Tail
Area - Ft ²	9644 (total)	1028
AR	1.357	.995
Δ_{LE} DEG	65	60
Δ_{TE} DEG	15	30
Span - Ft	114.41	31.28
C _R	153.33	50.61
C _T	15.26	13.68
MAC	103.14	35.68
T/C	3%	2 ^o Wedge

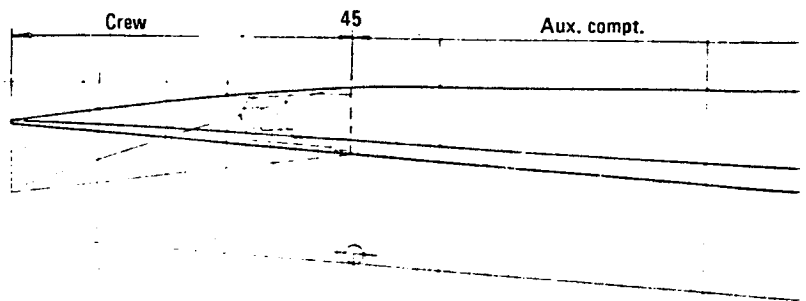
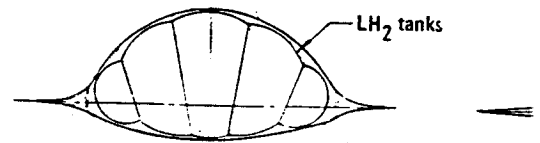
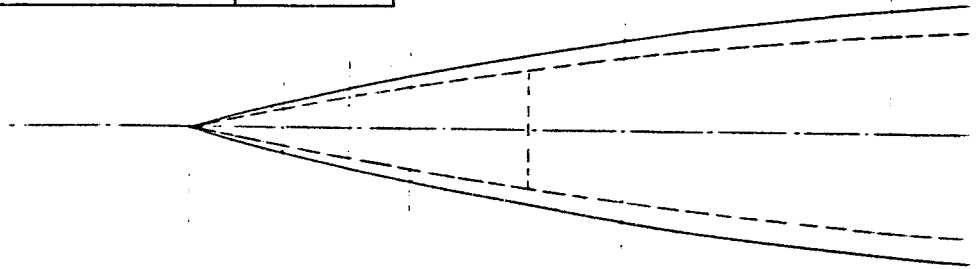

/L (HT4)	0	.0375	.0667	.0937	.1832	.300
Ft.	0	11.4	20.4	28.6		100

FOLDOUT FRAME

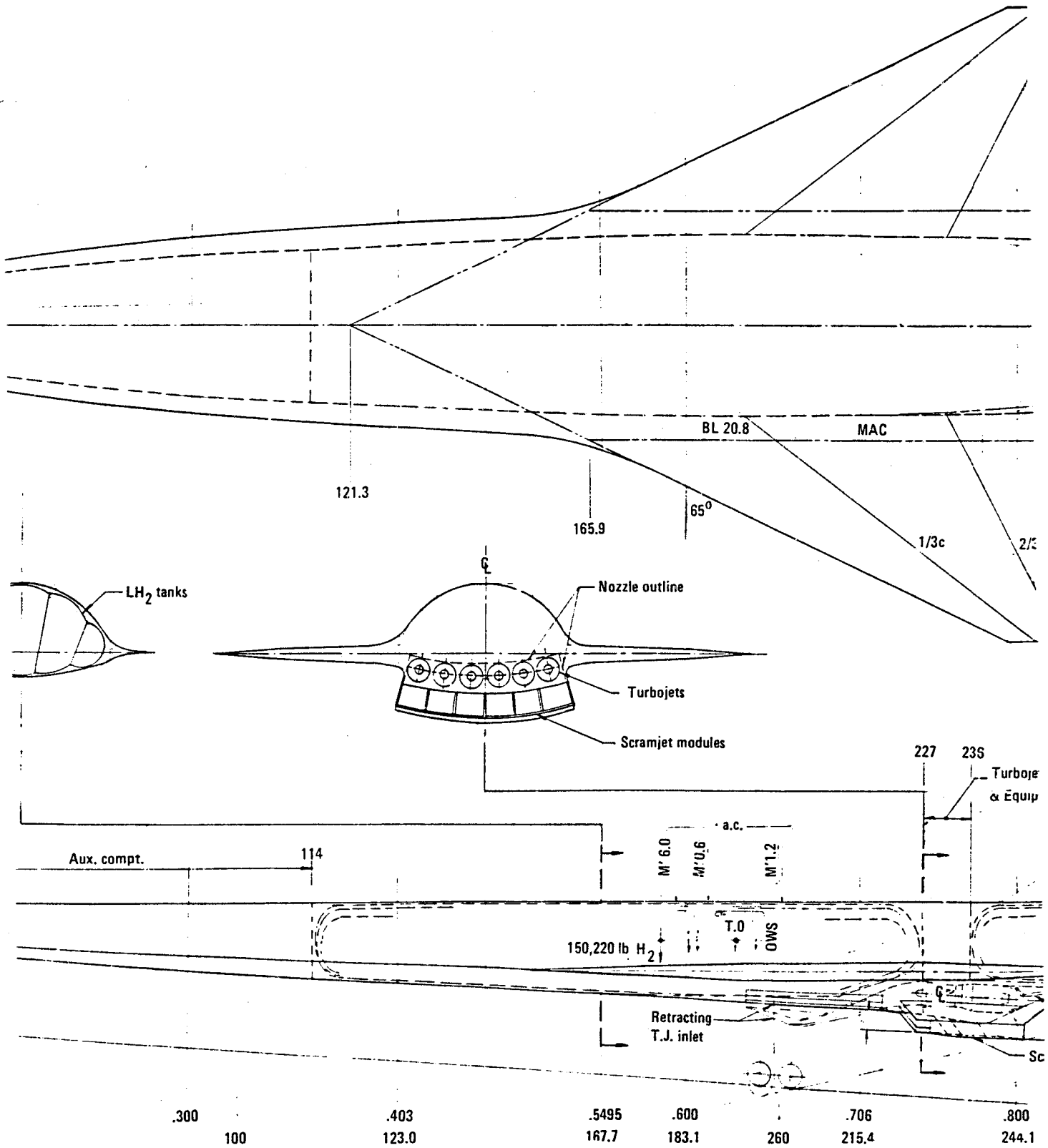

2
 EPODOUT EPODOUT

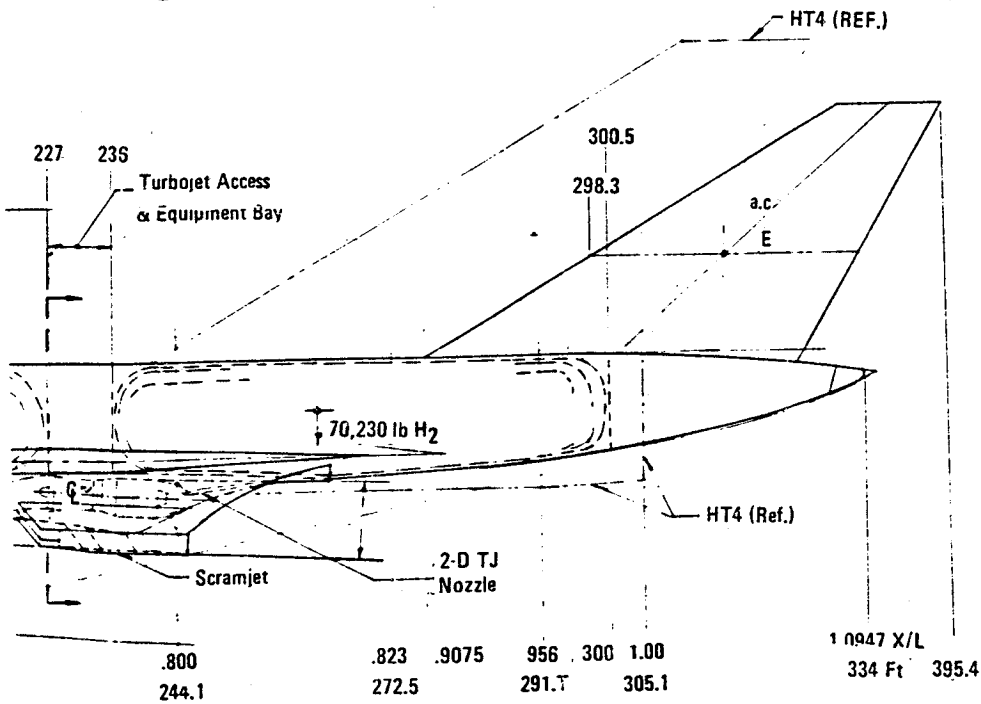
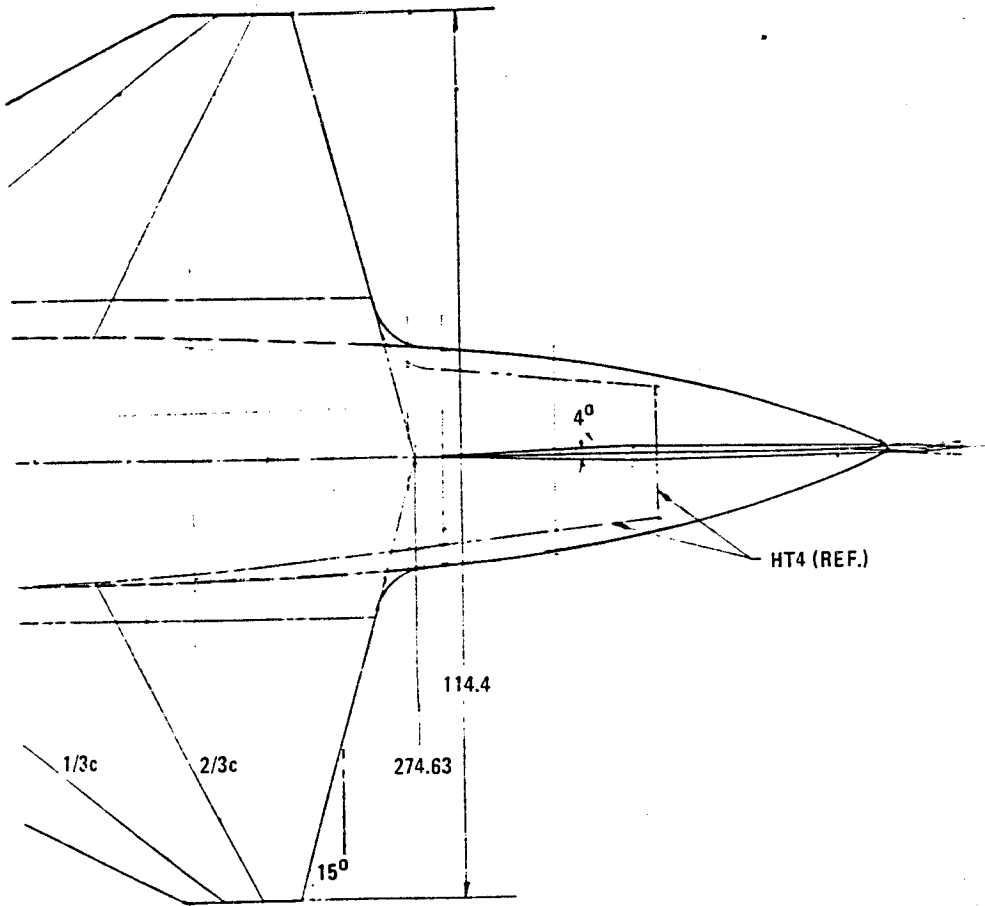

W_g = 646.130
 T/W = .581
 W/S = .67
 (Ac/S_{REF})_{TJ} = .0125
 Ac_{TJ} = 99.9

Figure 3. - HYCAT-1 general arrangement.

	Wing	Tail
Area - Ft ²	3644 (total)	1110
AR	1.357	.995
ΔLE°	65	60
ΔTE°	15	30
Span	144.41	33.23
C_R	153.33	52.6
C_r	15.26	14.22
t/c	3	2 ^o Wedge
MAC	103.14	37.08

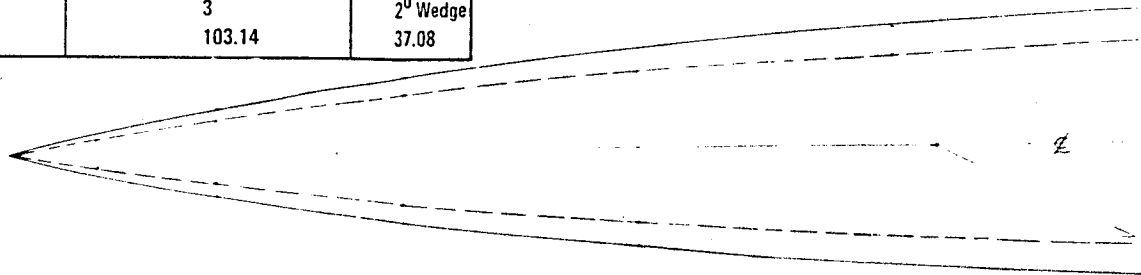

ORIGINAL PAGE IS
OF POOR QUALITY

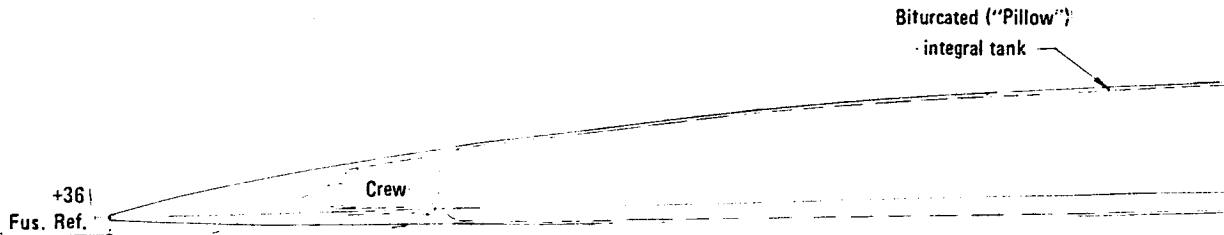
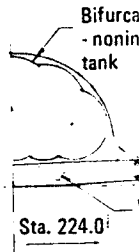

HT4 (Ref.)	X/L	Sta 0 (ft)	.0375	.0667	.0937	47.0	.1832	300	.403
		0	11.4	20.4	28.6		55.9	31.5	123.0

PRECEDING PAGES HAVE NOT FILMED

FOLDOUT FRAME

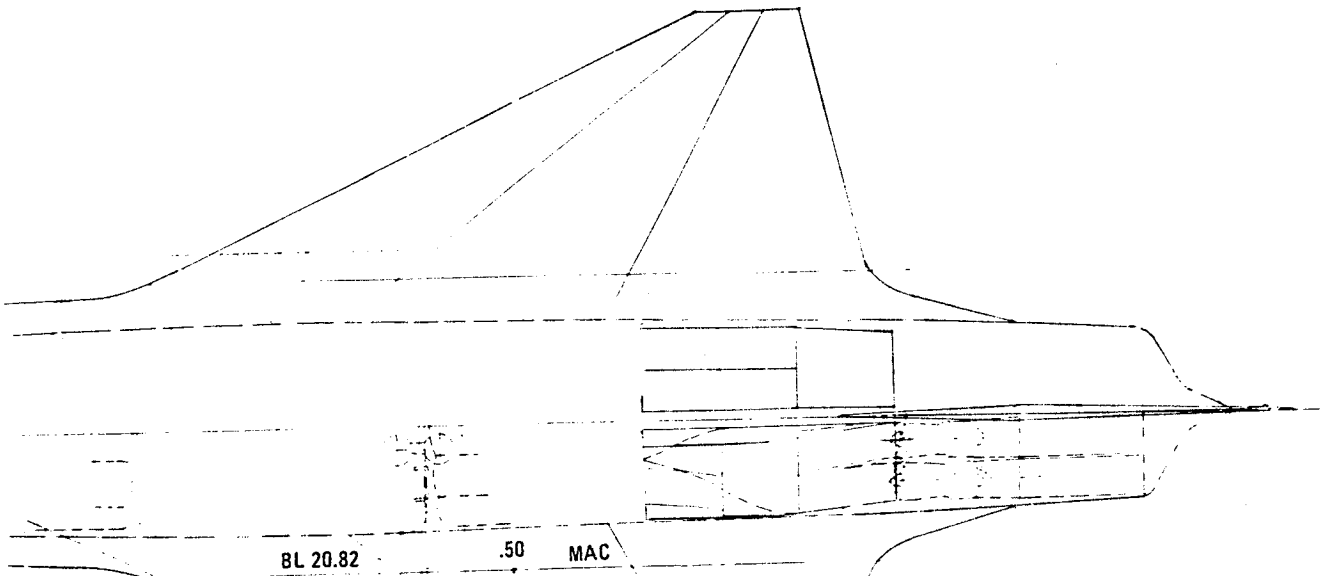

$T/W = .58$
 $A_c/S_{REF} = .0125$
 $A_{ox}/A_c = 2.9$

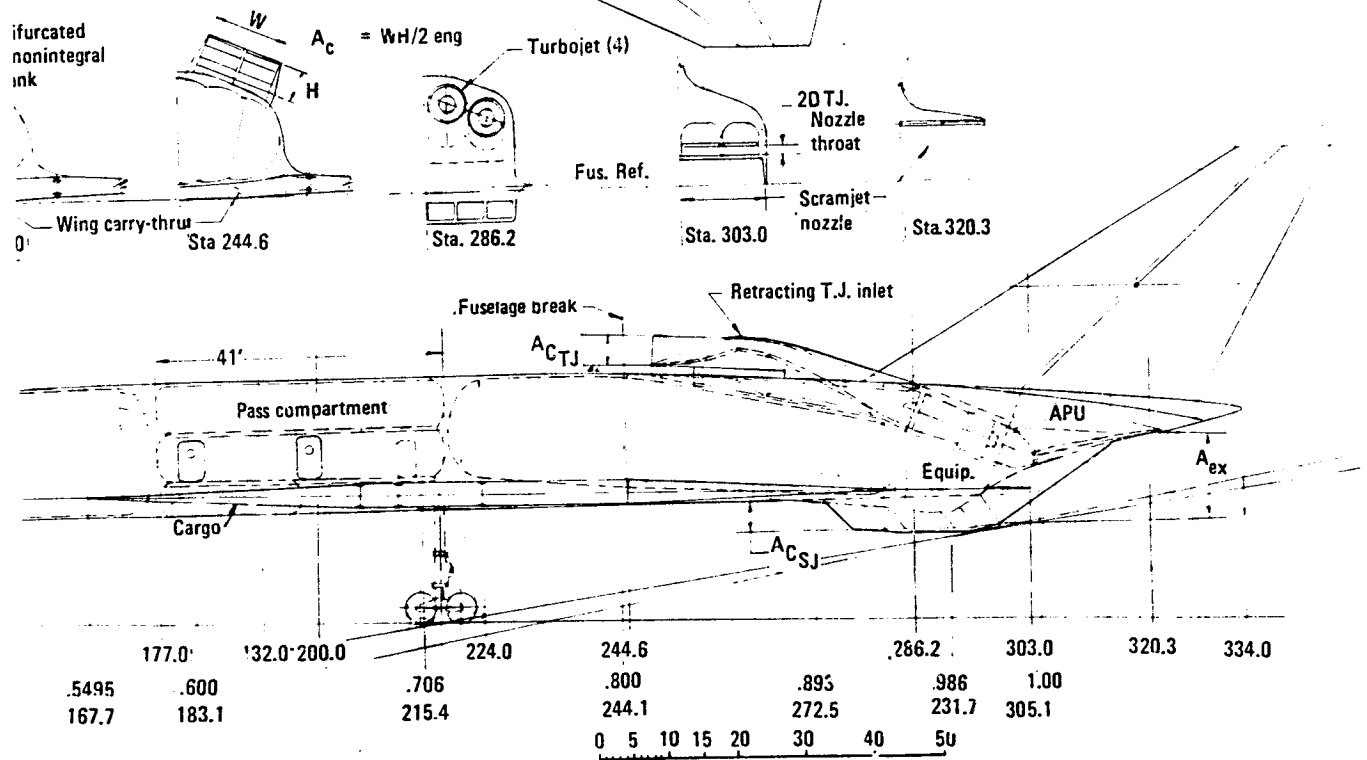

Figure 4. - HYCAT-2 general arrangement

FOLDOUT FRAME 2

PRECEDING PAGE DRAWING NOT FILMED

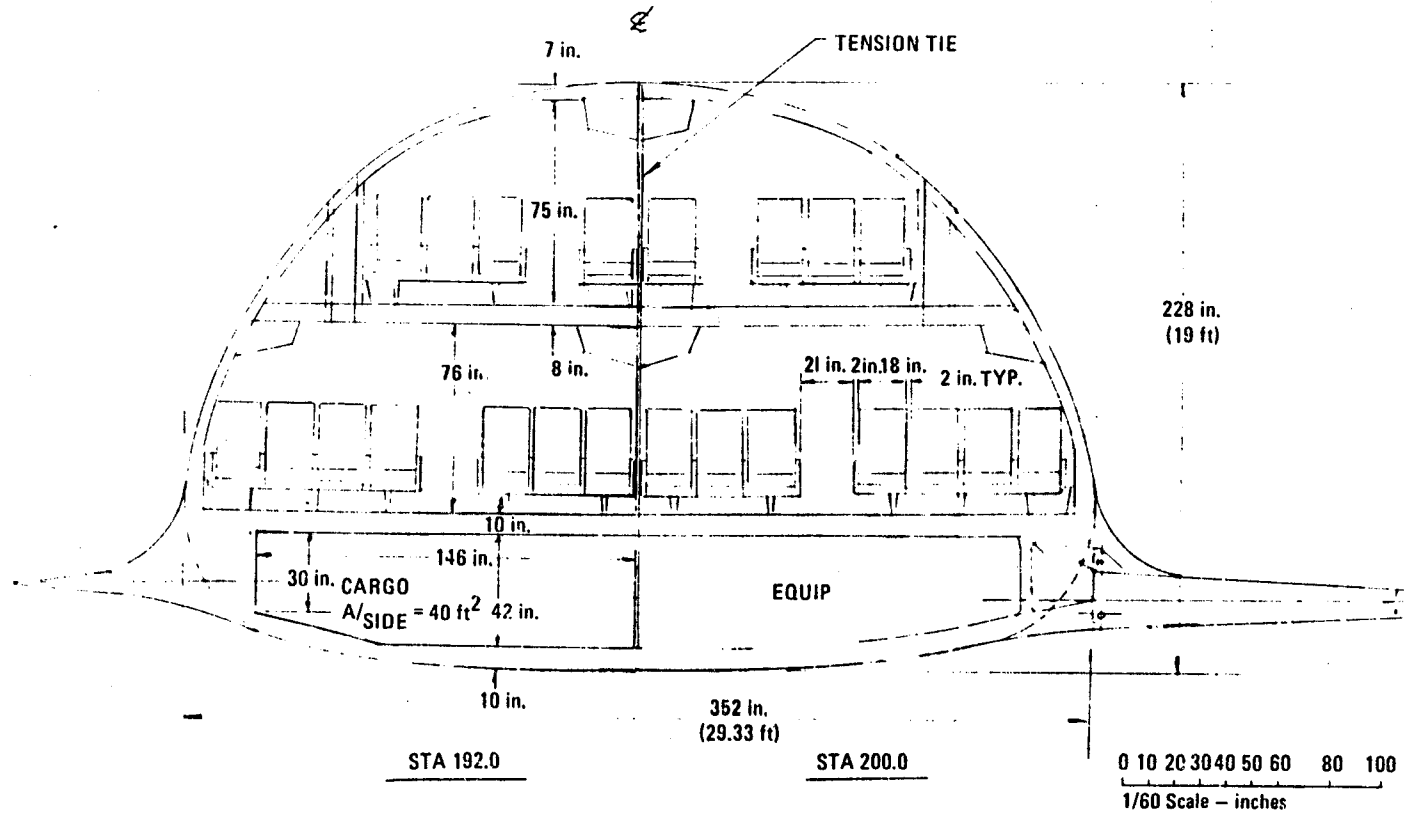

Figure 6. - HYCAT-2 cabin cross section

A qualitative comparison of the five configurations is shown in table 1. with the advantages and deficiencies of each listed for each criteria shown. Each configuration has certain advantages but on balance the -1 configuration was selected as the baseline reference because of the tunnel background data available as a check for our internal prediction methods. The -4 configuration was selected as the first alternate configuration because of its favorable propulsion installation, good low speed lift characteristics and the structural advantages of nearly circular fuel tanks and direct wing carry-thru structure. Disadvantages are the higher drag and weight of the exposed propulsion installation, a higher wing weight and the added weight and drag of the horizontal tail.

3.1.6 Evaluation of selected candidates. - The two selected candidates (HYCAT-1 and -4) were optimized by means of the parametric data generated by the hypersonic ASSET program described in 3.1.4. The optimization procedure and resulting data are described in detail in Volume II. The propulsion systems used in both aircraft consisted of turbojets with retracting variable-geometry inlets, and fixed-geometry, dual combustion mode scramjet engines. Other trade studies reported in Vol II consist of the effect of gross thrust deflection during cruise and the penalty incurred if the scramjet is not used in the Mach .9 to 3.5 region.

A weight comparison of the final optimized revision of both aircraft is shown in table 2. This table shows that the -4 configuration requires a 42-percent increase in gross weight over the -1 to accomplish the mission. The reasons for this large difference are described in detail in Vol II, Sect. 4.3.

Both of the configurations studied in this initial effort have certain advantages and deficiencies. These are magnified by the extreme growth sensitivity of the hypersonic aircraft to changes in inert or fuel weight. Table 3 lists the problem areas of each vehicle and suggested courses of action. While it is apparent that high drag and weight are bad, the modification of each configuration to exploit its best features is not so straightforward. In fact, it may be that the melding of the best features of both configurations may result in something similar to the HYCAT-2 configuration but with a means of obtaining a higher C_L at low speed, in particular during landing.

3.2 Configuration Refinement

The major conclusions drawn from this initial analysis of candidate configurations HYCAT-1 and HYCAT-4 can be summarized as follows:

	WING	V. TAIL (PER SIDE)
AREA - FT ²	9938.5	1400
ASPECT RATIO	1.50	1.0
ΛLE DEG	60	50
ΛTE DEG	35.78	26.15
SPAN	122.1	37.42
C _R	112.27	50.52
C _T	50.52	24.3
MAC	85.30	38.24
T/C %	3	3.49
λ	0.45	0.481

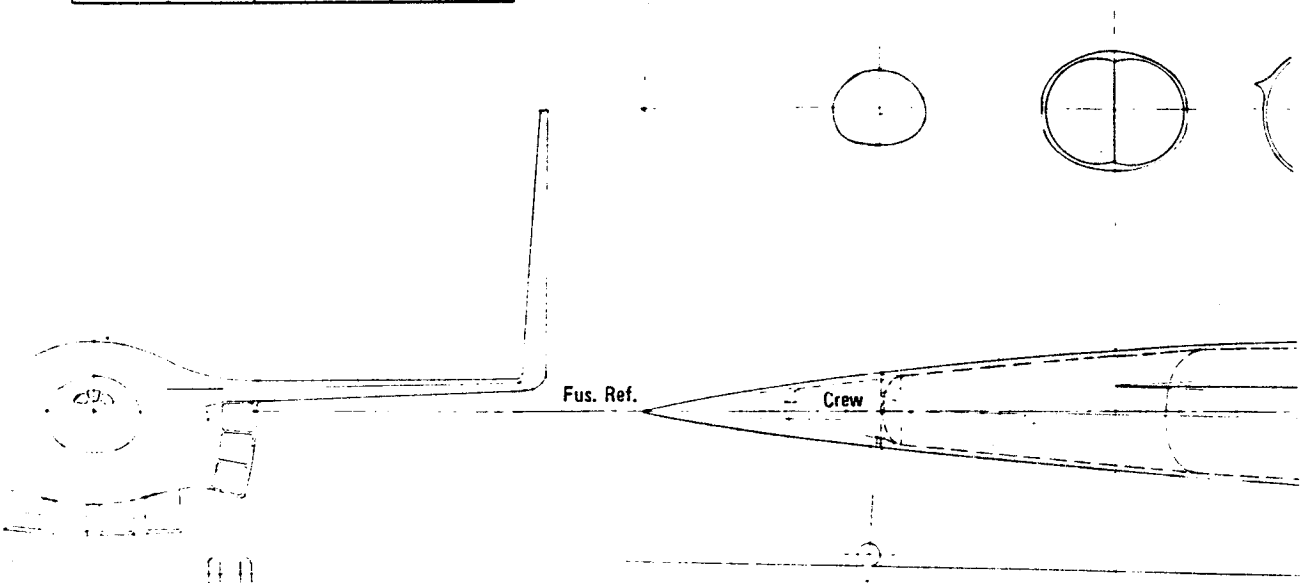
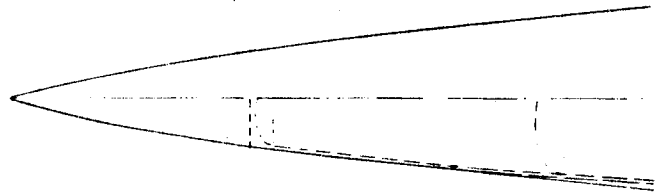

X/L REF	0	0.10	0.20
STA (ft)	0	33.4	66.8

FOLDOUT FRAME

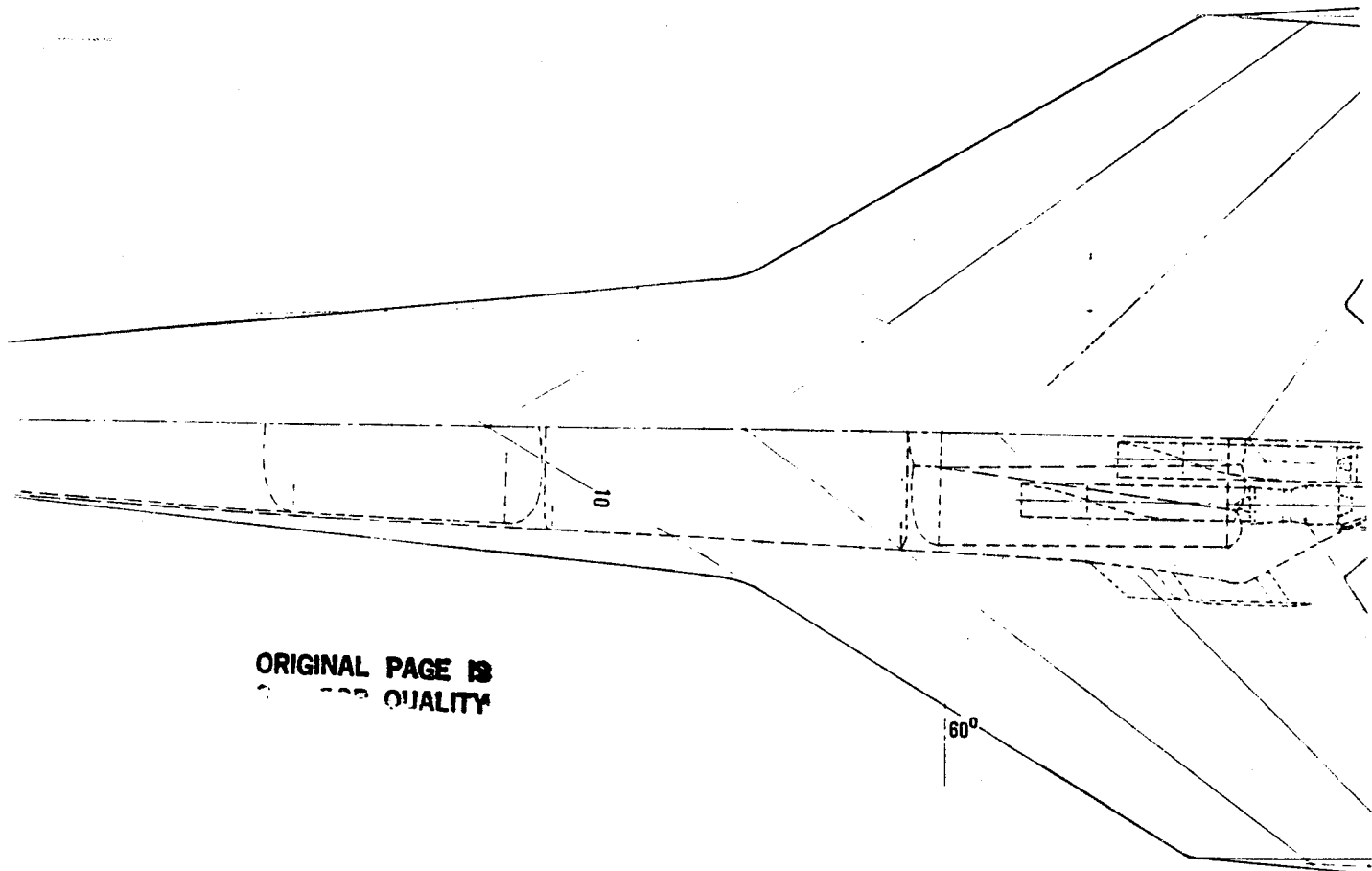

ORIGINAL PAGE IS
OF LOWER QUALITY

60°

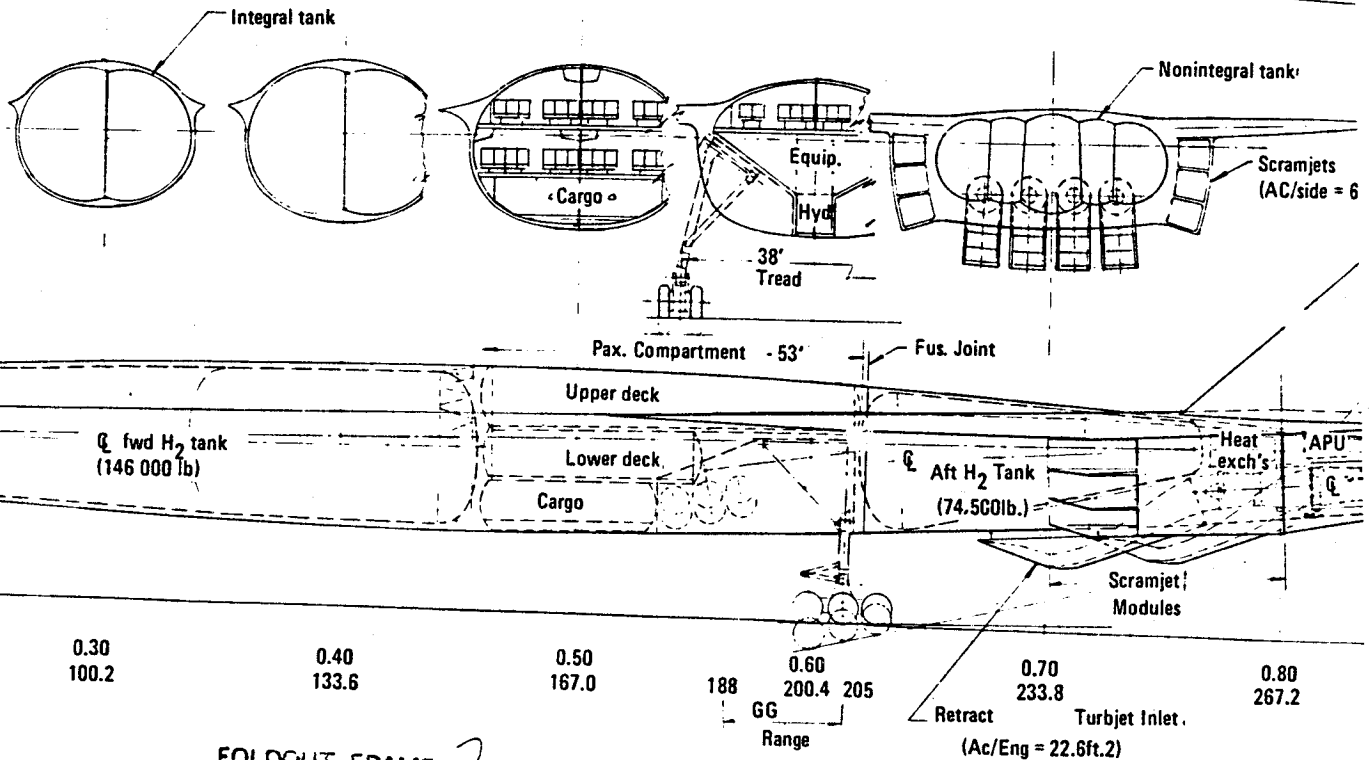

FOLDOUT FRAME 2

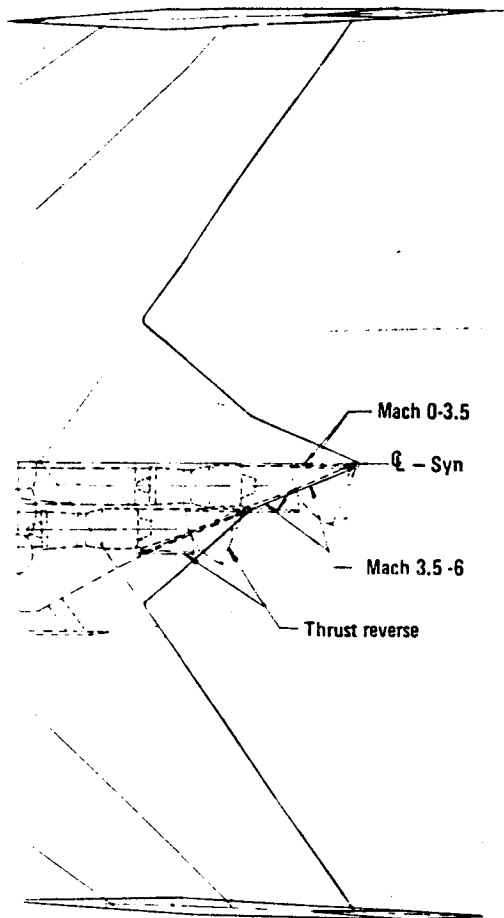

$$W_{TO}/S_{REF} = 65 \text{ lb/ft}^2$$

$$F_{SLS} (TJ)/W_{TO} = 0.58$$

$$A_{cSJ}/S_{REF} = 0.125$$

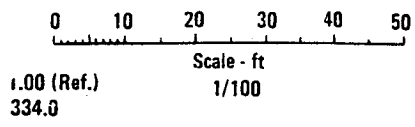
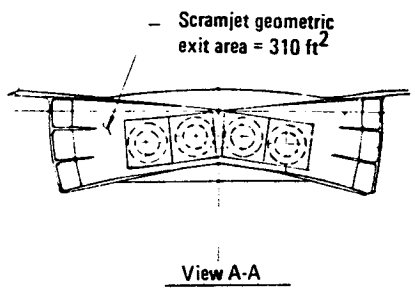
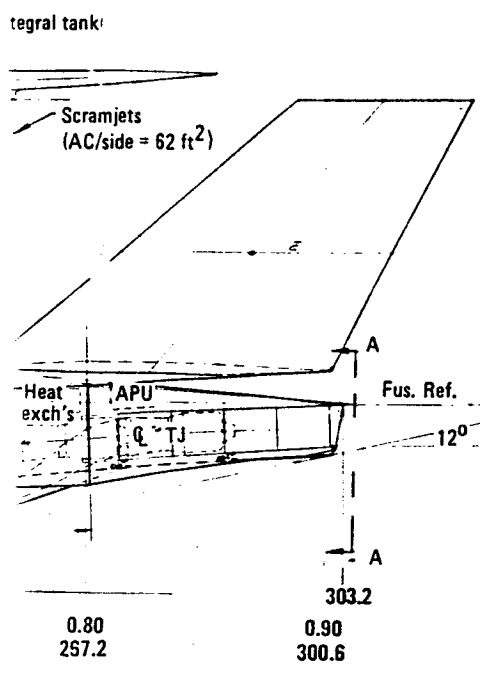
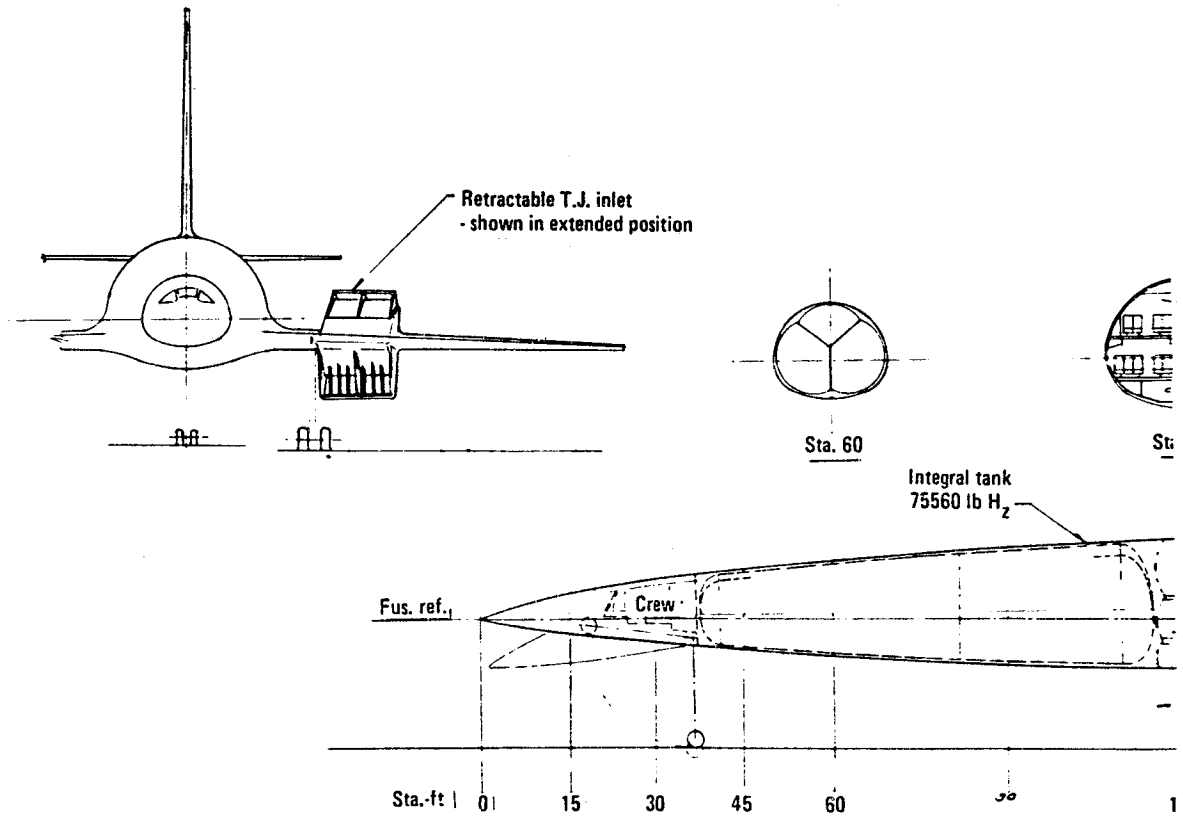
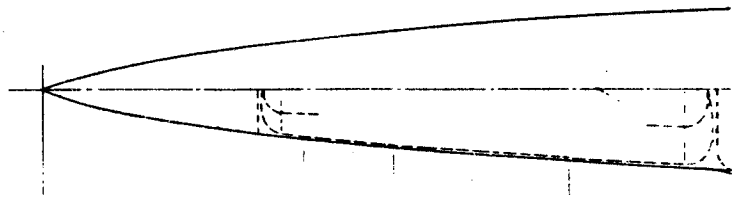

Figure 7. HYCAT-3 general arrangement.

~~SECRET~~ 3

	Wing	V. tail	H tail (exposed)
Area - ft ²	10 000	1495	600
Aspect ratio	2.154	1.0	1.0 (per side)
Δ LE. - deg	60	50	60
Span	146.75	38.66	
Cr	120.6	55.24	28.87
Ct	15.68	22.09	5.77
Mac	81.6	41.04	20.66
t/c %	3	4 ^o wedge	4 ^o wedge
λ	.13	.4	.2



FOLDOUT FRAME



PRECEDING PAGE MARK NOT FILMED

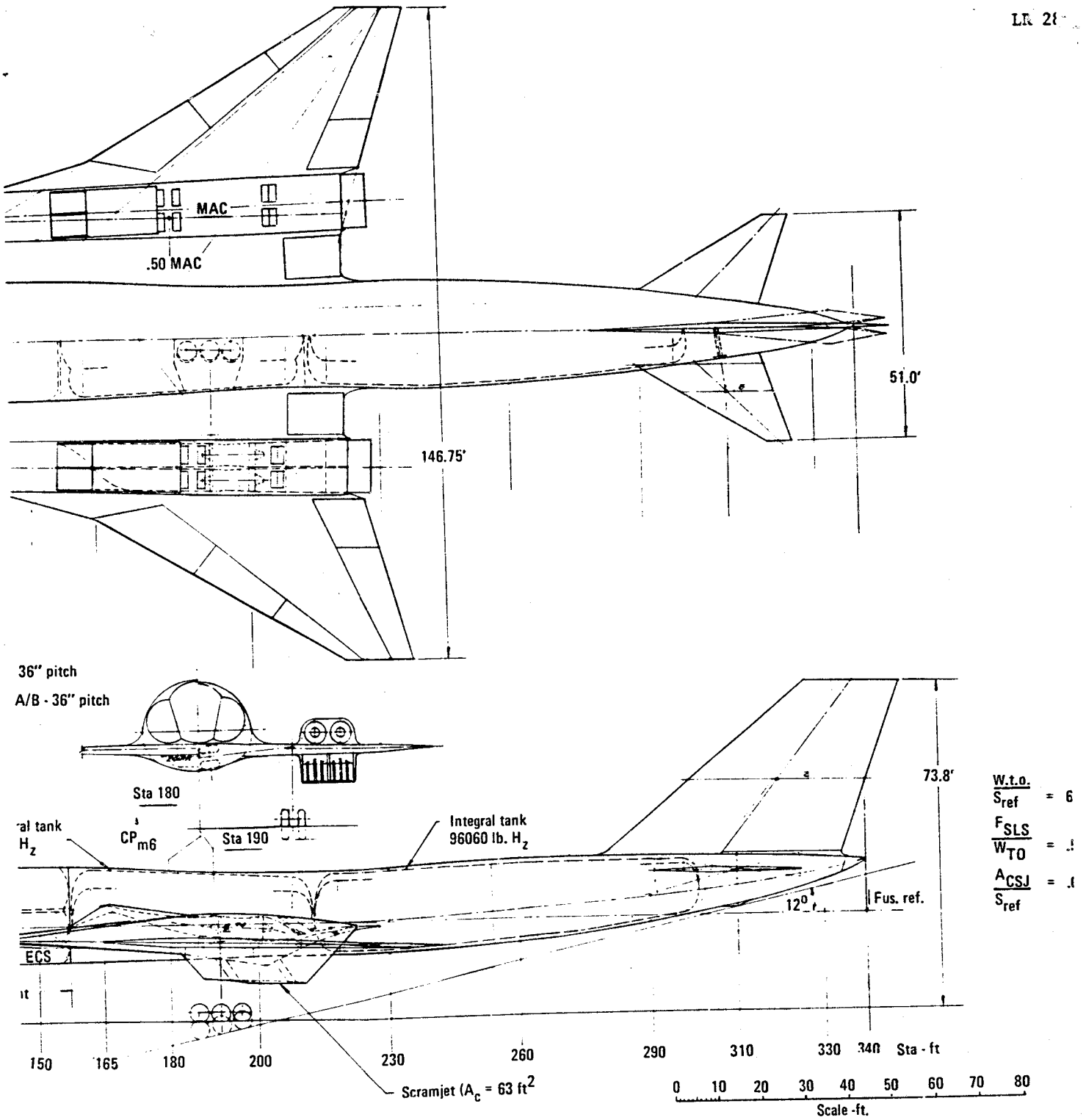
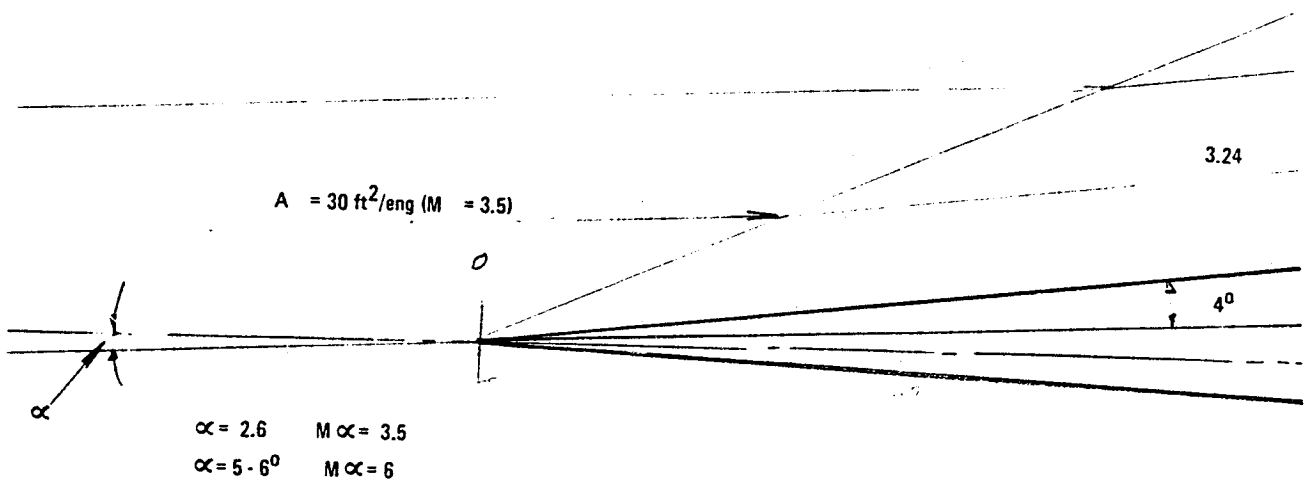

Figure 8. HYCAT-4 general arrangement.

FOLDOUT FRAME 2



FOLDOUT FRAME

FOLDOUT FRAME

PRECEDING PAGE BLANK NOT FILMED

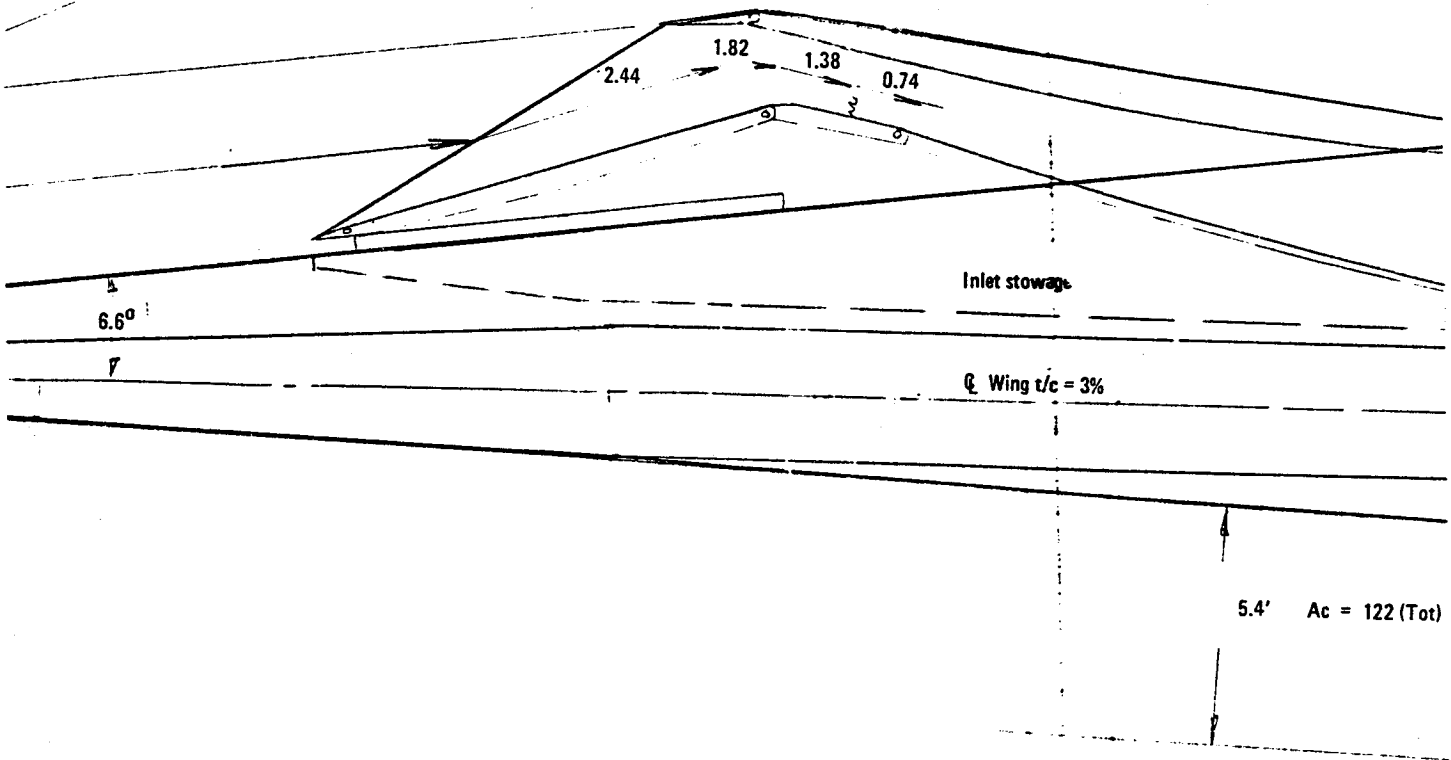

FOLDOUT FRAME 2

2-D

Blow in doors

Bypass

Blow in doors and throat

Primary nozz

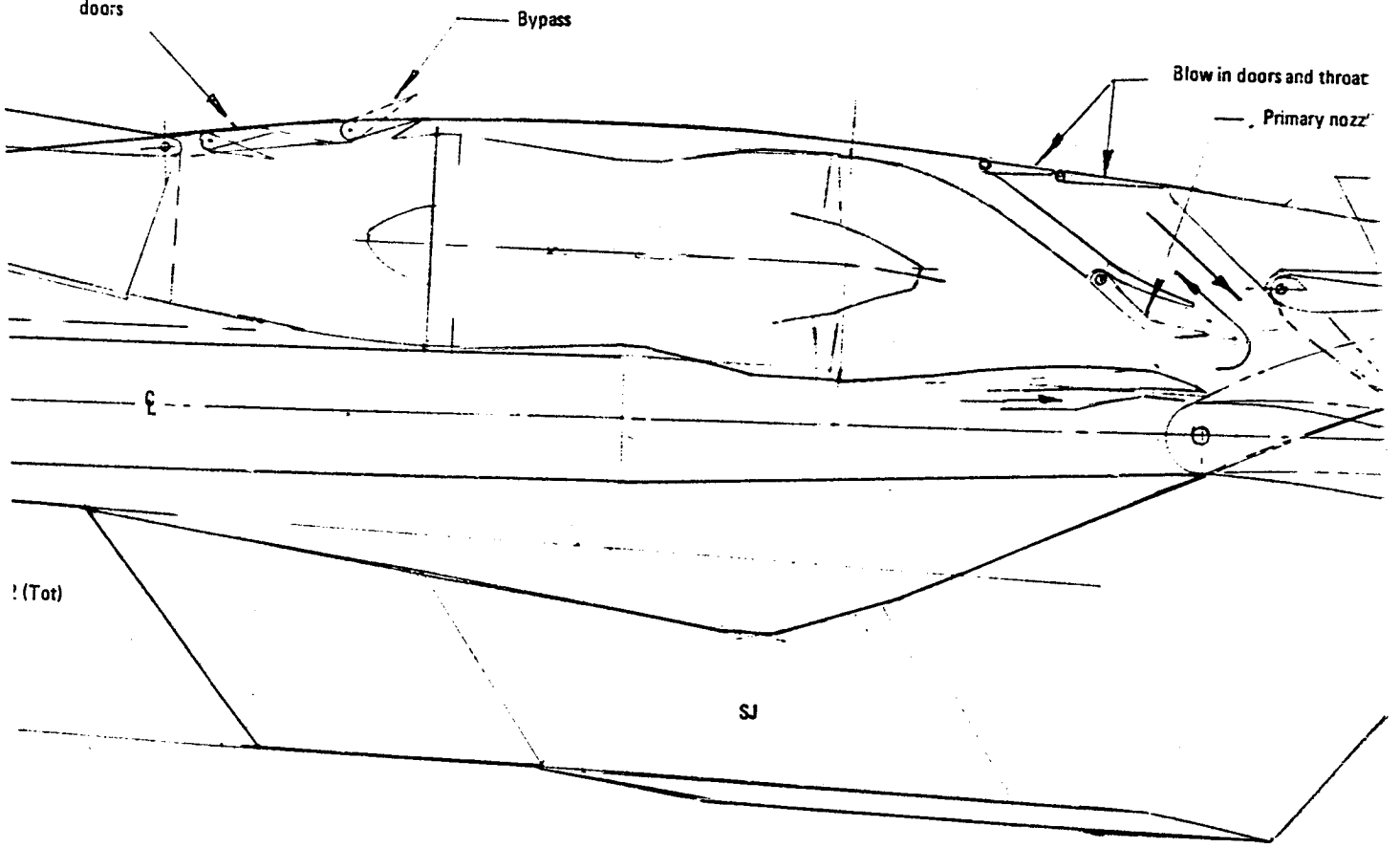

!(Tot)

SJ

FORN... 3

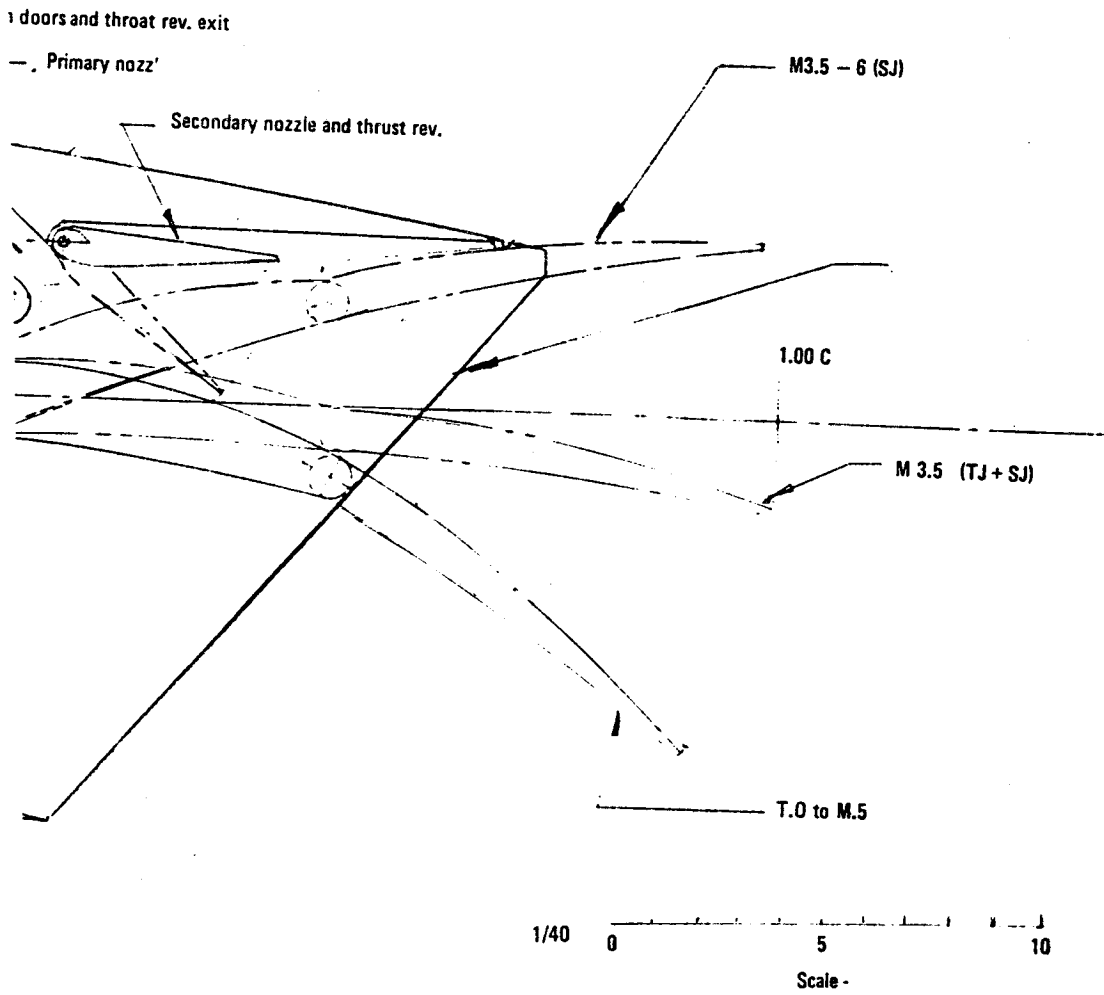
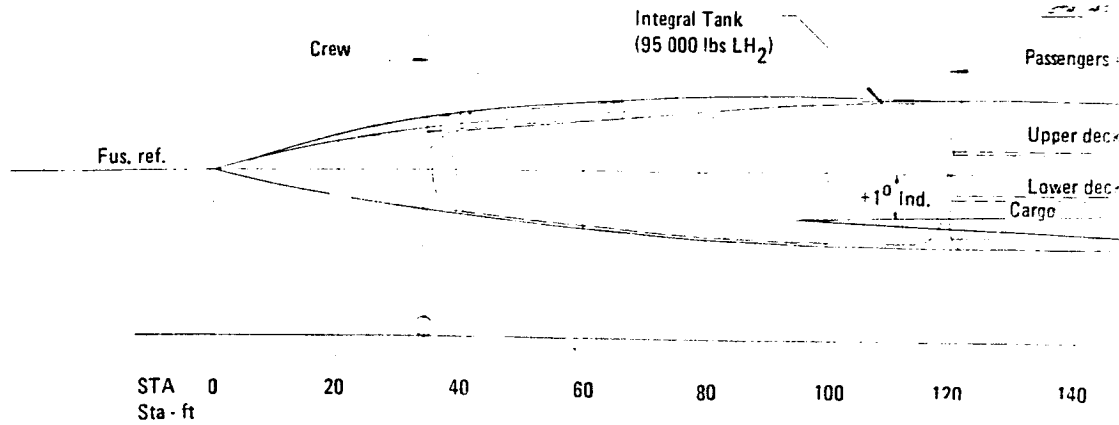
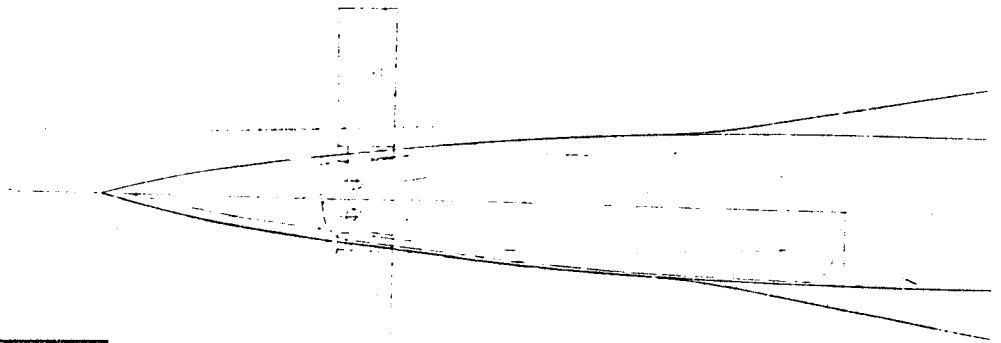

Figure 9. HYCAT-4 propulsion installation.

	Wing	V. Tail
Area - ft ²	14 356	2050
AR	1.322	1.0
Λ_{LE} - Deg	80 - 65	60
Span - ft	137.7E	44.72
C_R	269.16	63.89
C_T	0 (theo.)	25.56
MAC	165.09	47.46
λ	0 (theo)	0.4
t/c - %	2.5 at fus 3.0 at break	2° wedge



PRECEDING PAGE BLANK NOT FILMED

FOLDOUT FRAME

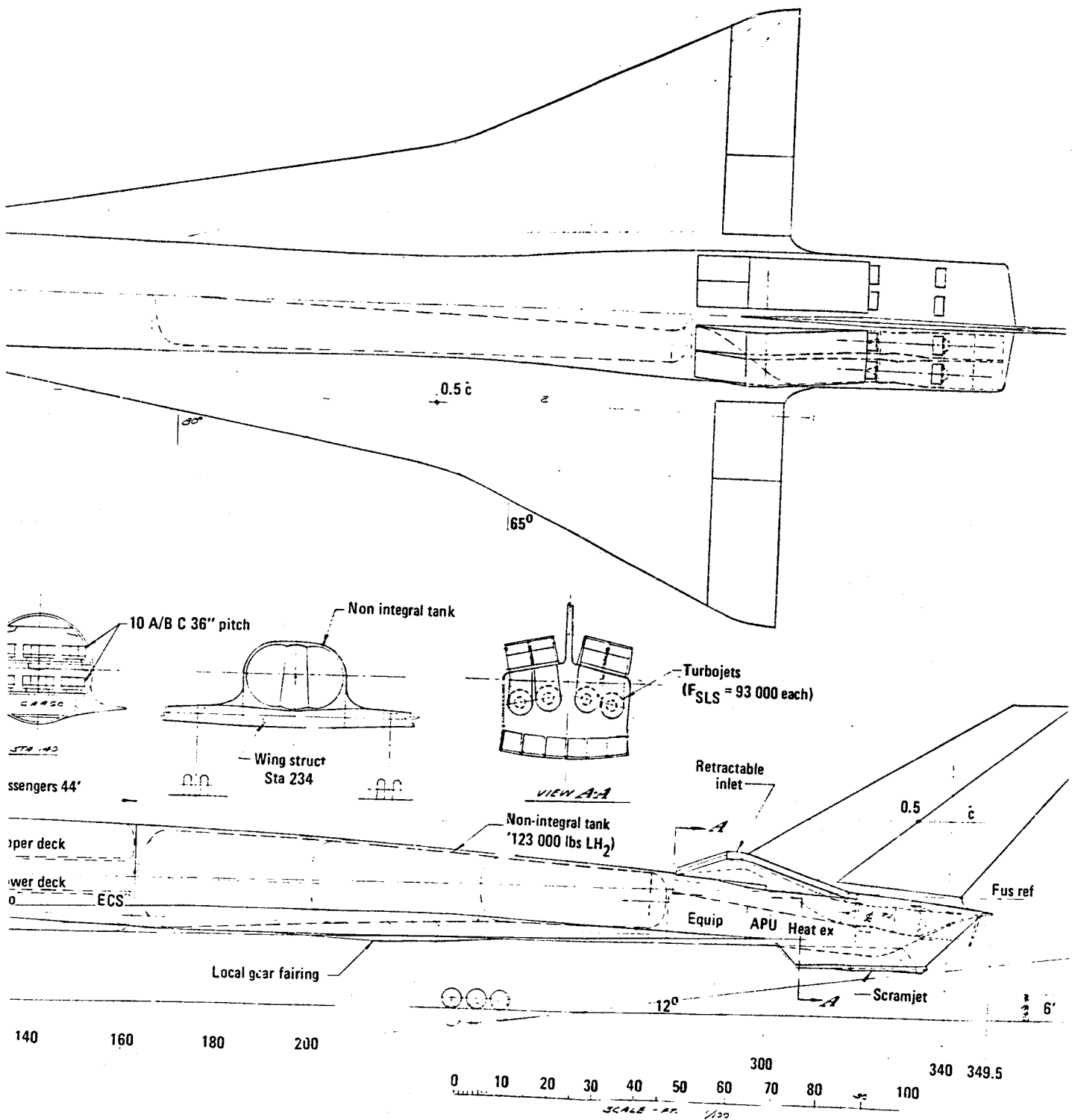

CL 1725-5 Hypersonic configuration

Fig

FOLDOUT FRAME 2

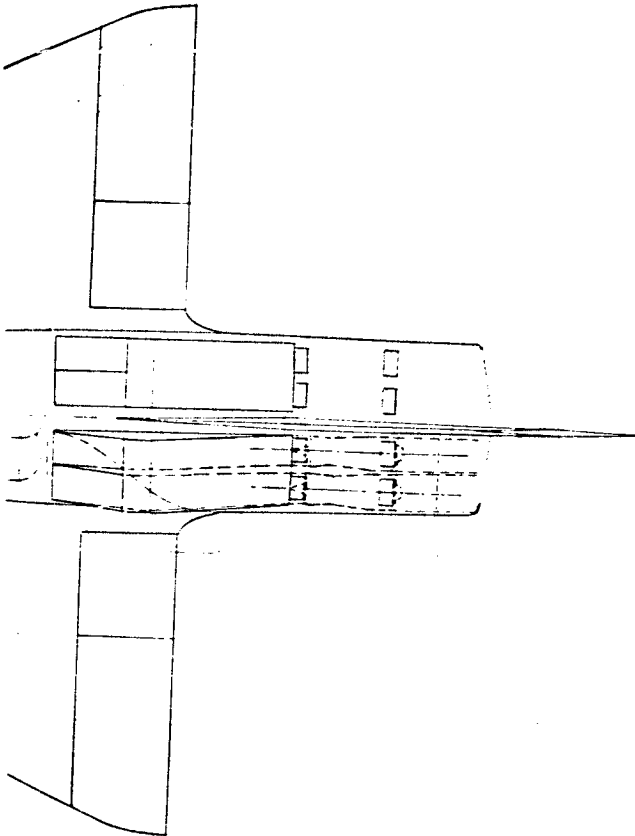

Turbojets
($F_{SLS} = 93\,000$ each)

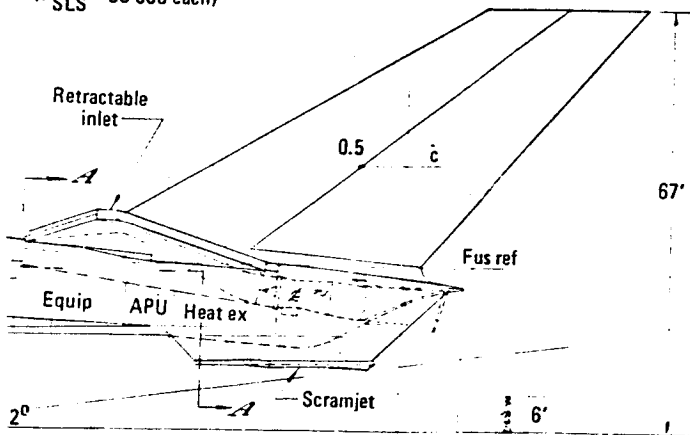

$W_g = 646\,000$
 $A_{cSJ} = 155\text{ ft}^2$
 $W/S_{REF} = 45\text{ lb/ft}^2$
 $S_{REF} = 14\,356\text{ ft}^2$
 $\frac{F_{SLS}}{W_g} = 0.58$

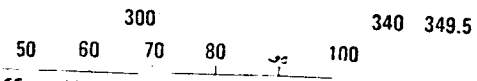

15.5 Hypersonic configuration

Figure 10. HYCAT-5 general arrangement.

ABOUT FIGURE 3

CONFIGURATION		Description	Propulsion Integration
BLENDED WING-BODY	<p>HYCAT-1</p>	<p>Basic HT4 shape with bottom mounted propulsion. Tandem TJ and SJ inlets. Forward single deck pass, compartment.</p>	<ul style="list-style-type: none"> ● Favorable pressure field ● Boundary layer growth = medium ● Unfavorable blockage of SJ inlet by TJ inlet (M 0 to 3.5) ● Aft underfuselage in jet wake ● Access to TJ's causes loss in volume.
	<p>HYCAT-2</p>	<p>Modified HT4 shape with aft mounted propulsion. Top TJ inlets with SJ on bottom. Mid-fuselage, double deck pass, compartment. Wing lower to permit struct-carry thru.</p>	<ul style="list-style-type: none"> ● Favorable pressure field for SJ's ● Top location of TJ inlet will cause problems due to boundary layer ingestion and separation at low speed. ● Boundary layer growth = max. ● Good access to TJ's. ● Remote location of thrust from C.G. accentuates trim problem.
WINGED BODY	<p>HYCAT-3</p>	<p>High wing - Aft side mounted S.J.'s with TJ's on aft bottom. Symmetric nozzle. Mid-fuselage double deck pass, compartment. Twin vert. tails.</p>	<p>Symmetric nozzle negates thrust vector trim problems.</p> <ul style="list-style-type: none"> ● TJ inlets in favorable press field ● Wing-fuselage corner flow into SJ not desirable. ● Weak press-field to SJ's - wing shock intersects inlet ● Good access to TJ's.
SEMI-BLENDED WING BODY	<p>HYCAT-4</p>	<p>Low wing - Wing mounted propulsion with TJ's over wing - SJ's under Area ruled fuselage with double deck pass, compartment. Conventional vert. and horiz. tail.</p>	<ul style="list-style-type: none"> ● Medium strength shock field. ● Minimum boundary layer growth ● No TJ/SJ inlet interference ● Channel flow between fuselage and pods undesirable ● Possible engine out trim problem (supersonic) ● Close coupling of thrust and C.G. ● Good access to TJ's and SJ's.
WINGED BODY	<p>HYCAT-5</p>	<p>Low wing double delta. Aft mounted propulsion with top TJ inlets - SJ's on bottom. Sears-Haack semi-blended body with double deck pass, compartment between tanks Canard for low speed trim.</p>	<ul style="list-style-type: none"> ● Same comments as for HYCAT-2 above.

FOLDOUT FRAME

PRECEDING PAGE BLANK NOT FILMED

	Aerodynamic Characteristics	Structural and Tankage	Volumetric Efficiency	Passenger Location	Pr
	<ul style="list-style-type: none"> ● Lift of flattened forebody contributes to high hyper-sonic L/D. ● Difficult to get C.G. for enough forward to match aero center. ● Lateral directional stability adequate ● Low speed C_L limited - no high lift - low AR. 	<ul style="list-style-type: none"> ● Limited wing box carry thru - load taken by frames or integral tanks ● Gear must retract into wing-fairing required. ● Fuel tank weight penalty for pillow tanks 	<ul style="list-style-type: none"> ● Loss in volume due to TJ access ● Single deck max. compartment causes 3000 ft³ vol. loss compared to double deck 	<ul style="list-style-type: none"> ● Good access for loading and serving ● Not protected by wing structure ● Max. C. G. travel 	
	<ul style="list-style-type: none"> ● Same as above -1 except that wing must be moved aft to counteract required shift of C.G. with aft propulsion. ● Fuselage deepened to permit double deck max. compartment (higher drag) 	<ul style="list-style-type: none"> ● Same as above -1 except wing has direct carry thru. 	<ul style="list-style-type: none"> ● Better than -1 above due to double deck pax. compartment. ● Some volume loss in propulsion area. 	<ul style="list-style-type: none"> ● Over-wing access required ● Protected by wing structure ● Min. C.G. travel 	
	<ul style="list-style-type: none"> ● Forebody wave drag high due to SJ inlet flow field contraction desired. ● Tip fins may have undesirable interaction at low speed. 	<ul style="list-style-type: none"> ● Fwd tanks circular - minimum wt. ● No wing carry thru - weight penalty ● High wing requires long, heavy gear. 	<ul style="list-style-type: none"> ● Large loss in volume due to gear stowage 	<ul style="list-style-type: none"> ● Good access ● Not protected by wing structure ● Vulnerable to gear collapse ● Min C.G. travel 	
h	<ul style="list-style-type: none"> ● Added drag due to exposed nacelles and horizontal tail ● Good low speed C_L due to flaps and drooped ailerons ● Minimum trim drag - long tail arm ● Horizontal allows use of flaps 	<ul style="list-style-type: none"> ● Direct wing carry thru - min. wt. ● Wing bending relief due to propulsion location ● Horiz-tail causes fuselage bending loads 	<ul style="list-style-type: none"> ● Very good - (Prop. not in fuselage) ● Small volume loss due to gear stowage 	<ul style="list-style-type: none"> ● Over-wing access required ● Partial protection by wing structure ● Min. C.G. travel 	
2	<ul style="list-style-type: none"> ● No particular aero advantage unless inboard panel L.E. could be made subsonic ● Lower C_L makes airport performance critical ● Canard required for rotation and trim at low speed. 	<ul style="list-style-type: none"> ● Direct wing carry thru - min. wt. ● Circular fwd. tanks and pass. compt. - min. wt. ● Gear retracts into wing - fairing required 	<ul style="list-style-type: none"> ● Good - some loss in propulsion area 	<ul style="list-style-type: none"> ● Moderate over-wing access required ● Partial protection by wing structure ● Min. C.G. travel 	

FOLDOUT FRAME 2

TABLE 1. CANDIDATE CONFIGURATION COMPARISON

Passenger Location	Producibility Index*	Comments
<ul style="list-style-type: none"> ● Good access for loading and serving ● Not protected by wing structure ● Max. C. G. travel 	1.0 (Baseline Value)	<ul style="list-style-type: none"> ● Selected as baseline reference because of tunnel data and previous studies ● Tandem inlet not acceptable - revision required
<ul style="list-style-type: none"> ● Over-wing access required ● Protected by wing structure ● Min. C.G. travel 	0.8	<ul style="list-style-type: none"> ● Expected to be similar in performance to -1 ● TJ inlet location marginal
<ul style="list-style-type: none"> ● Good access ● Not protected by wing structure ● Vulnerable to gear collapse ● Min C.G. travel 	0.9	<ul style="list-style-type: none"> ● Scramjet inlet location marginal
<ul style="list-style-type: none"> ● Over-wing access required ● Partial protection by wing structure ● Min. C.G. travel 	0.7	<ul style="list-style-type: none"> ● Selected as 1st alternate configuration ● Good low speed characteristics may negate lower cruise L/D ● Body lift could be increased by chines or flattening of body
<ul style="list-style-type: none"> ● Moderate over-wing access required ● Partial protection by wing structure ● Min. C.G. travel 	0.75	<ul style="list-style-type: none"> ● Potential of hypersonic double delta not known ● Could evolve to hypersonic arrow wing?

*Structure only - no equipment
(lower value = lowest mfg. cost)

TABLE 2. - COMPARISON OF OPTIMIZED HYCAT-1 AND -4

			-1		-4	
General Characteristics:						
Wing loading	kg/M ²	(lb/ft ²)	373.5	(76.5)	488.2	(100)
Thrust/weight	daN/kg	(-)	0.49	(0.50)	0.44	(0.45)
Capture area/wing area	-	-	0.011	(0.011)	0.012	(0.012)
Weights						
	kg	(lb)				
Gross weight			307 382	(677 649)	435 196	(959 426)
Total fuel			108 453	(239 094)	164 140	(361 860)
Fuel fraction	-		.3528	.3528	0.3772	.3772
Payload			19 051	(42 000)	19 051	(42 000)
OEW			179 877	(396 555)	252 005	(555 565)
Std plus operating items			6 611	(14 575)	7 065	(17 560)
Empty weight			173 265	(381 978)	244 040	(538 006)
Structure - fraction	-		.2517	.2517	0.2893	.2893
Wing			22 402	(49 387)	48 920	(107 849)
Tail			2 631	(5 800)	3 783	(8 339)
Body			36 282	(79 987)	48 005	(105 831)
Ldg. gear			11 716	(25 829)	15 551	(34 283)
Surface controls			2 720	(5 997)	3 662	(8 073)
Nacelle and eng. section			1 622	(3 576)	5 979	(13 180)
Propulsion fraction	-		.2106	.2106	0.1943	.1943
Engines (T.J.)			20 276	(44 701)	25 837	(56 960)
Air induction (T.J.)			4 145	(9 138)	5 313	(11 713)
Scramjets			9 724	(21 437)	11 489	(25 329)
Fuel tankage and systems			30 127	(66 418)	41 323	(91 100)
Systems, furnishings and equip. - fraction			0.1014	0.1014	0.0772	0.0772
Mission Performance:						
Cruise L/D (average)	-		5.21	5.21	4.72	4.72
Cruise specific range	km/kg	(n.mi./lb)	0.1425	(.0349)	0.0878	(.0215)
Descent range	km	(n.mi.)	891	(481)	600	(324)
Block fuel required	kg	(lb)	52 267	(203 410)	143 302	(315 921)
FAR T.O. fld. dist.	m	(ft)	3 016	(9 895)	2 118	(6 950)
FAR Ldg. fld. dist.	m	(ft)	3 203	(10 510)	3 182	(10 440)
Energy utilization	$\frac{kJ}{seat\ km}$	$\frac{Btu}{seat\ n.mi.}$	5 971	(10 494)	9 274	(16 298)

PRECEDING PAGE BLANK NOT FILMED

TABLE 3. - CONFIGURATION PROBLEM AREAS

PROBLEM	POSSIBLE COURSES OF ACTION	RESULT
HYCAT-1:		
1. Turbojet inlet blocks S.J. Mach 0.8 to 3.5	<ul style="list-style-type: none"> ● Move inlet to top aft of fuselage ● Modify config. 	<ul style="list-style-type: none"> ● Marginal region for TJ inlet operation
2. Passenger compartment vol. not efficient. - cg travel too large	Move to mid - fuselage and double deck passengers	<ul style="list-style-type: none"> ● Better vol. efficiency ● Reduce cg travel
3. Low value of C_L during low speed T.O. and Ldg.	<ul style="list-style-type: none"> ● Add canard ● Use elevons as flaps 	<ul style="list-style-type: none"> ● Added weight and reduced wing lift ● cg must be controlled or a horizontal tail is required
HYCAT-4:		
1. Heavy wing wt.	Decrease AR Decrease leading edge sweep	<ul style="list-style-type: none"> ● Decreases low speed C_L ● Reduces wt. and high speed drag
2. Propulsion drag and weight	Bury TJ's in fuselage - put inlet on top or bottom	<ul style="list-style-type: none"> ● Decrease fus. volume ● Increases TJ base drag to the Mach 3.5 - 6.0 region ● Moves cg aft
3. Increase fuselage lift	<ul style="list-style-type: none"> ● Add chines or flatten fuselage 	<ul style="list-style-type: none"> ● Noncircular fuel tanks (added weight) ● Less efficient fuel volume

- The landing field length is the critical sizing constraint.
- Turbojet accelerator engines should be buried within the airframe when they are not used. This serves to minimize both drag and nacelle weight.
- The arrangement of the propulsion system in HYCAT-1 blocks the scramjet inlet in the Mach 0-3.5 flight regime. The inlet retraction and stowage concept is too complex.
- Lift provided by a flattened vehicle forebody (or by use of strakes) is important to improve hypersonic L/D.
- Wing weight is critical in that higher aspect ratios, while providing higher low-speed lift, incur an excessive weight penalty.
- The use of a horizontal tail (or canard) is required to provide trim for relative changes in center of gravity and aerodynamic center. A further advantage is that it allows the use of drooped ailerons (flaperons) for low speed lift.
- The forward passenger compartment location on HYCAT-1 is not efficient and the center of gravity movement is too large.

Consideration of the above conclusions in the initial effort resulted in the selection of the basic HYCAT-1 shape for modification and refinement because of its aerodynamic efficiency at cruise. The following modifications were made:

- A new propulsion configuration was generated to overcome the objections of the HYCAT-1 arrangement.
- The passenger cabin was moved to mid-fuselage in a double-deck arrangement similar to that shown for HYCAT-2.
- A horizontal tail and wing flaps were added. This alleviates, to some extent, the low speed lift disadvantages of a low aspect ratio wing.

The final baseline configuration designated HYCAT-1A is shown in figure 11. This is the starting point for the design trade studies reported in detail in Volume II, and is the configuration on which the propulsion studies described in the following section were conducted.

3.3 Propulsion Concepts

As the primary focus of the study, two propulsion concepts were evaluated: 1.) a concept with a variable-geometry inlet and turbojet engine and a separate fixed-geometry inlet and scramjet engine and 2.) a concept with a variable-geometry inlet supplying air to both a turbojet and a ramjet engine. The supersonic combustion cycle was used with the fixed-geometry inlet since the scramjet cycle is less dependent on variable geometry to achieve the proper inlet throat area over the required speed range.

3.3.1 Separate Inlet, Turbojet-scramjet system. - This concept is shown schematically in figure 12. It consists of a variable-geometry, retractable inlet for the turbojet engine and a fixed-geometry inlet, combustor and nozzle for the scramjet. The dual mode engine uses thermal choking by means of heat addition in the subsonic combustion mode from Mach .9 to Mach 4.5. Supersonic combustion is initiated at Mach 4.5 and is continued to Mach 6 for use throughout cruise. The turbojet is used for landing, takeoff and acceleration to the scramjet takeover point at Mach 3.5 to 4, at which time the turbojet inlet is retracted as shown. A common exit nozzle is used for both the turbojet and scramjet. Advantages of this concept are:

- A simple fixed-geometry cruise engine with no moving parts reduces complexity.

- The supersonic mode reduces the engine heat load and internal pressure due to reduced static temperature and pressure in the inlet, combustor and nozzle.
- Potential for operation at higher Mach numbers such as Mach 10.

The disadvantages are:

- The exposed fixed-geometry scramjet causes large installation drag in the critical transonic region as well as during subsonic cruising flight (cold flow drag).
- The fixed-geometry of the scramjet limits the inlet air flow capability at lower Mach numbers.
- The turbojet inlet retraction requirement causes problems in mechanization and sealing.

3.3.2 Common variable-geometry inlet, turbojet-ramjet system. - This system is shown schematically in figure 13. The method of operation is similar to that of the turbojet-scamjet combination with the exception that a common inlet supplies both the turbojet and ramjet up to Mach 3.5 at which time the turbojet is shut off and only the ramjet is used up to and including cruise. The interior surface of the inlet aft of the cowl, the ramjet diffuser, and the ramjet module are all regeneratively cooled by the hydrogen fuel.

The advantages of the ramjet compared to the scramjet are:

- Lower installation drag at low supersonic and subsonic speeds.
- Inlet retraction is not required as it is for the turbojet inlet of the turbojet-scamjet system.
- Higher thrust in the supersonic and low hypersonic speed regime due to the variable inlet and nozzle.
- Less development risk and facilities requirements.

The disadvantages are:

- Higher unit heat flux at cruise due to the subsonic mode of operation (near stagnation pressure and temperature).
- Limited in maximum flight Mach number. A rapid deterioration in thrust and impulse occur at speeds higher than the Mach 6 of this study, compared to the scramjet.

A further comparison of the two systems will be found in latter sections of this report.

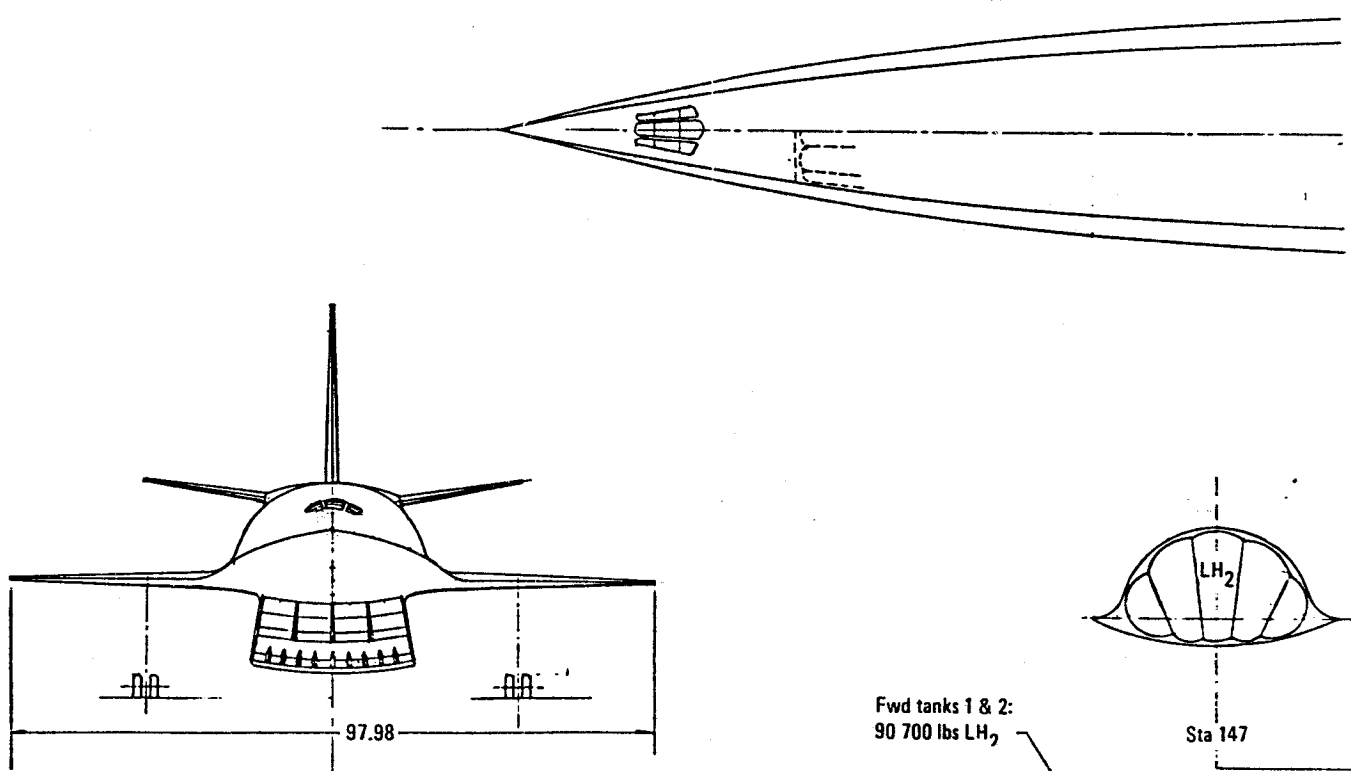

Fwd tanks 1 & 2:
90 700 lbs LH₂

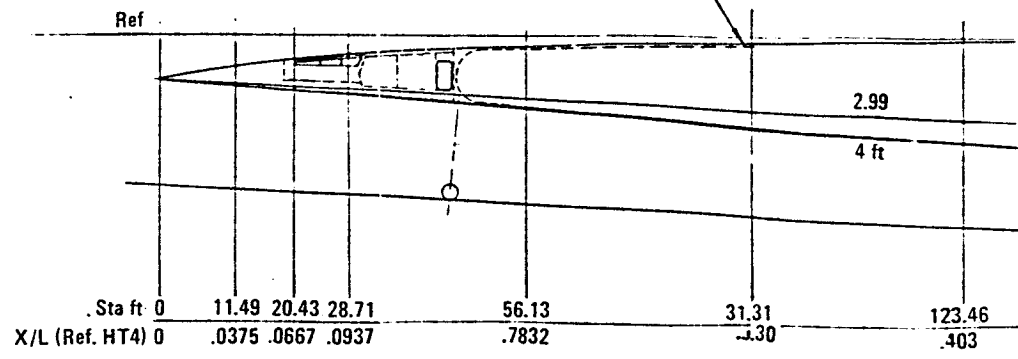

FOLDOUT FRAME

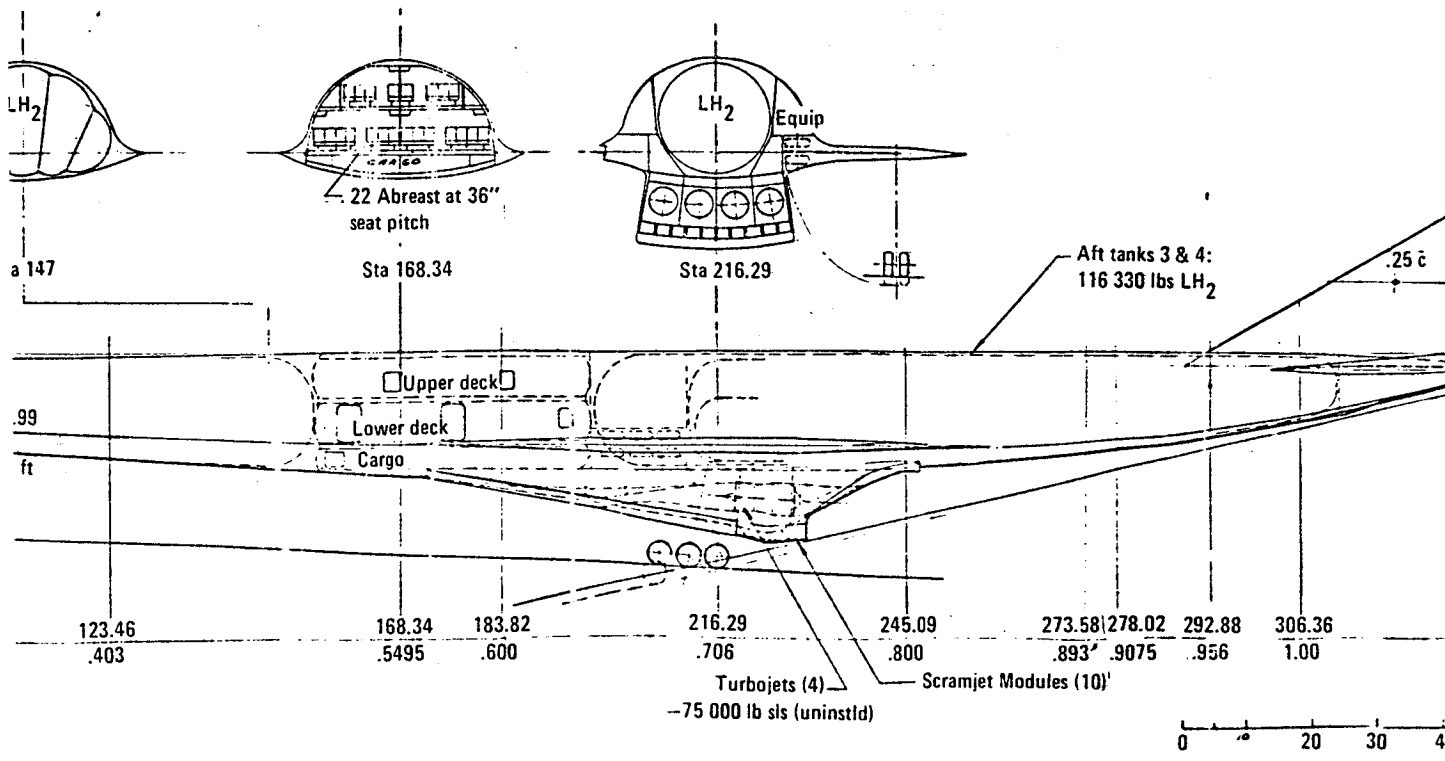
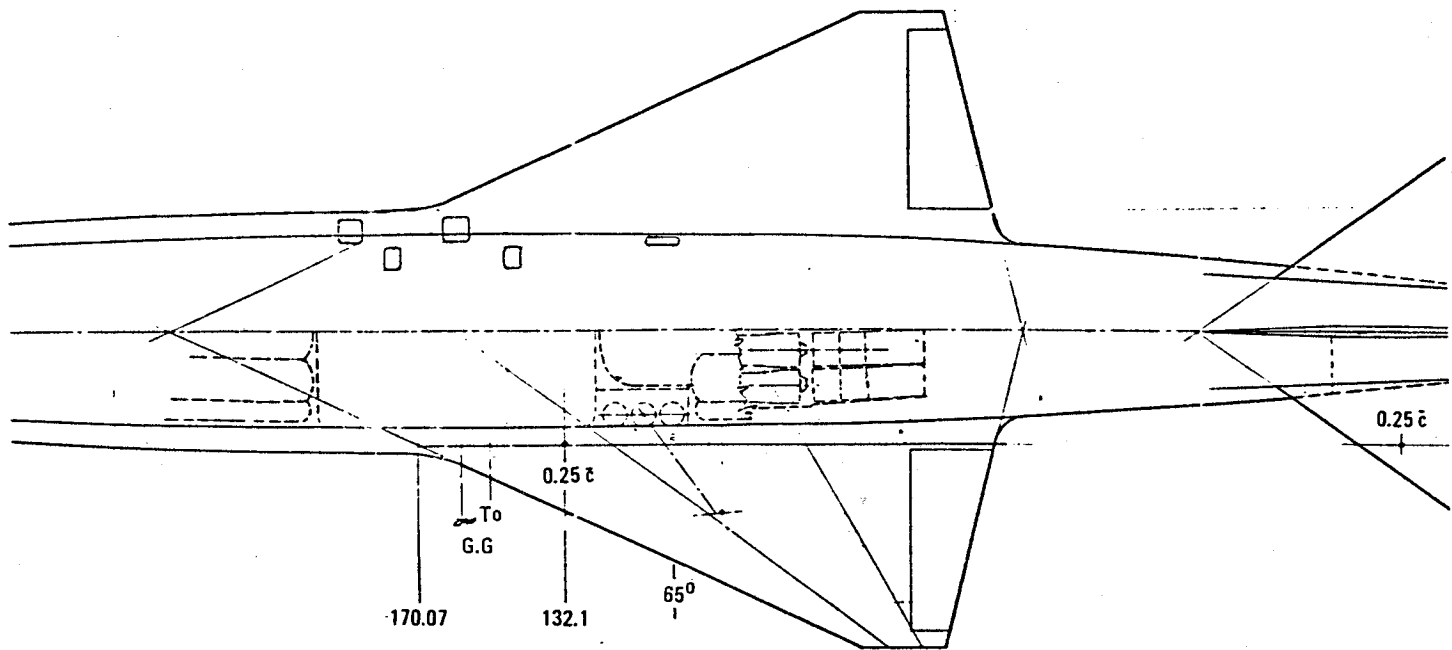

FOLDOUT FRAMS 2

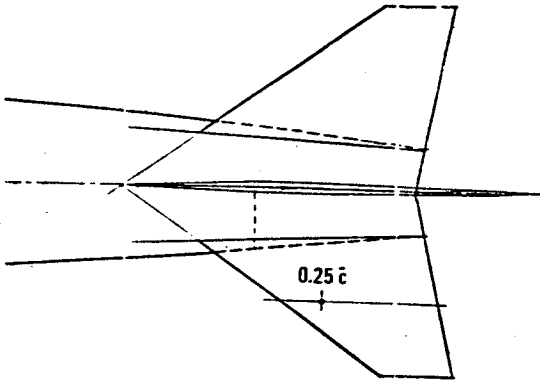

Gross wt (est) 600 000 lb
 Wing loading 85 lbs/ft²
 Thrust/wt (sts) 0.50
 Fuel wt. 207 030 lb

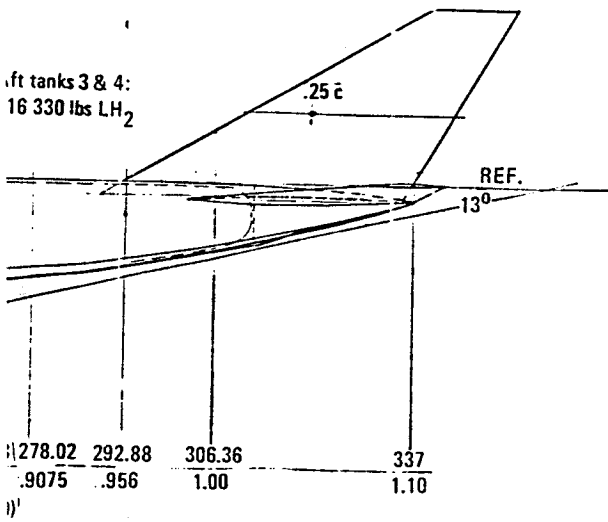
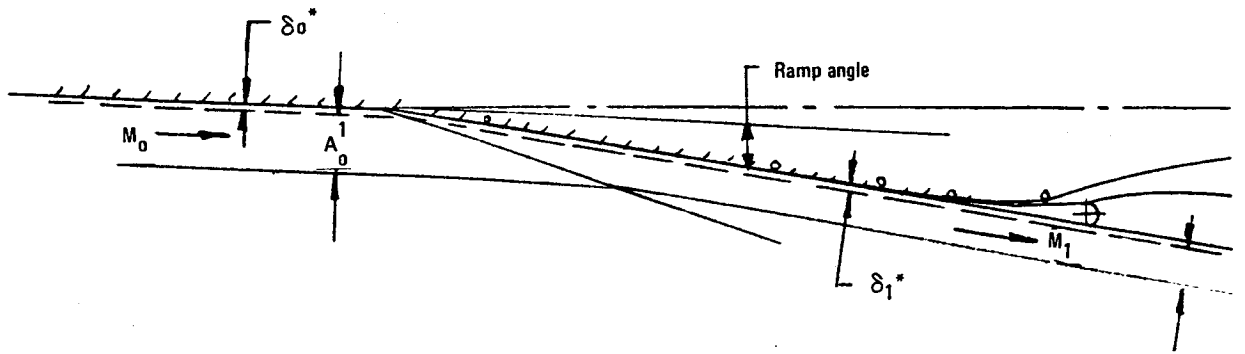
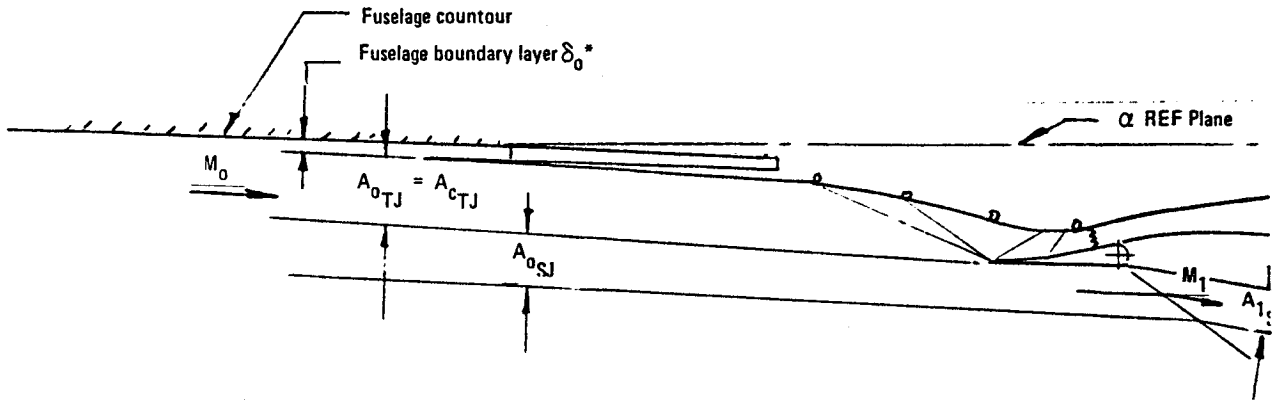

Figure 11. General arrangement
 baseline version of
 HYCAT-1A.

FOLDOUT FRAME 3



PRECEDING PAGE BLANK NOT FILLED

SOLD OUT 1942ZJ

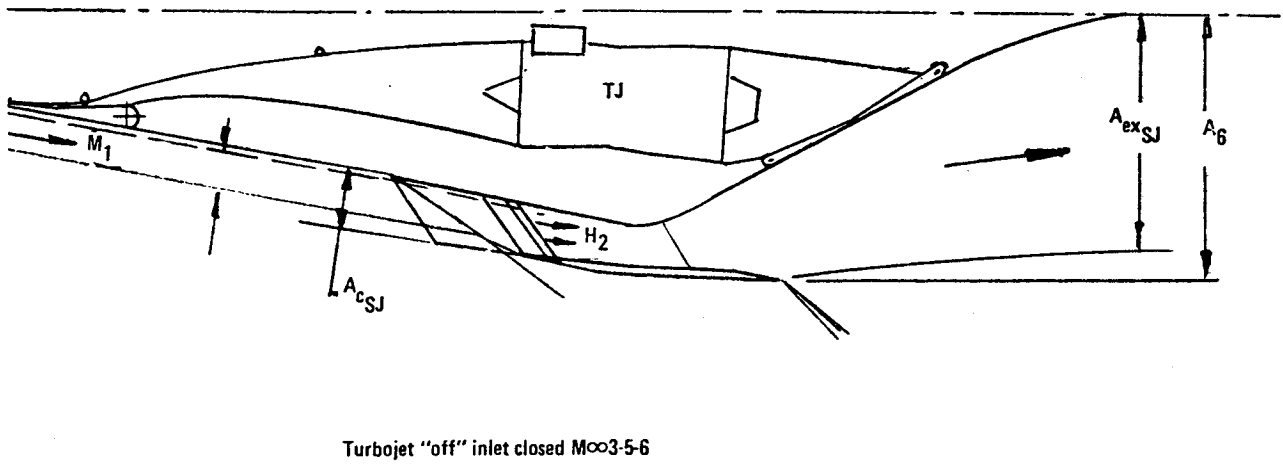
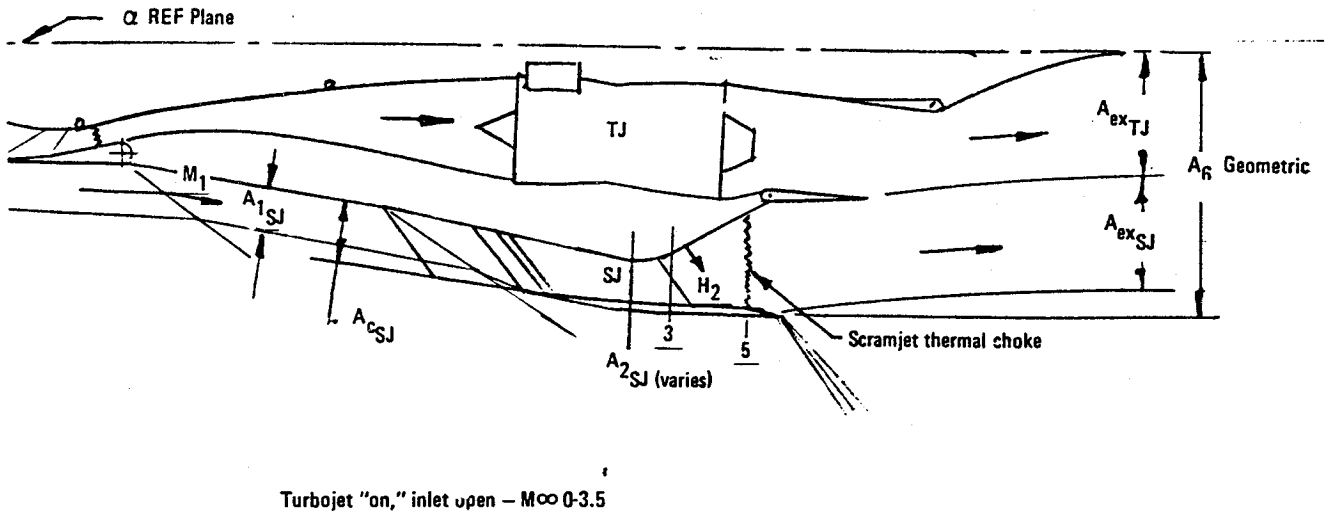
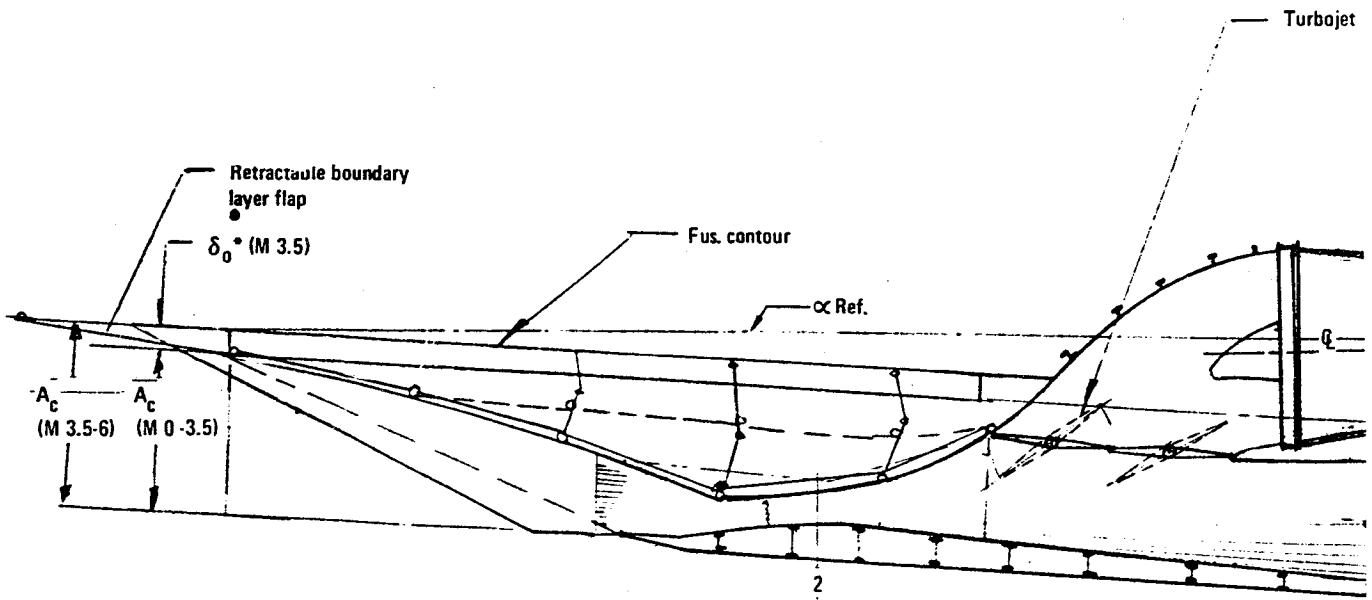

Figure 12. Separate inlet, turbojet-scramjet system schematic.



FOLDOUT FRAME

PRECEDING PAGE BLANK NOT FILMED

— Turbojet shutoff doors — close at mach 3.5

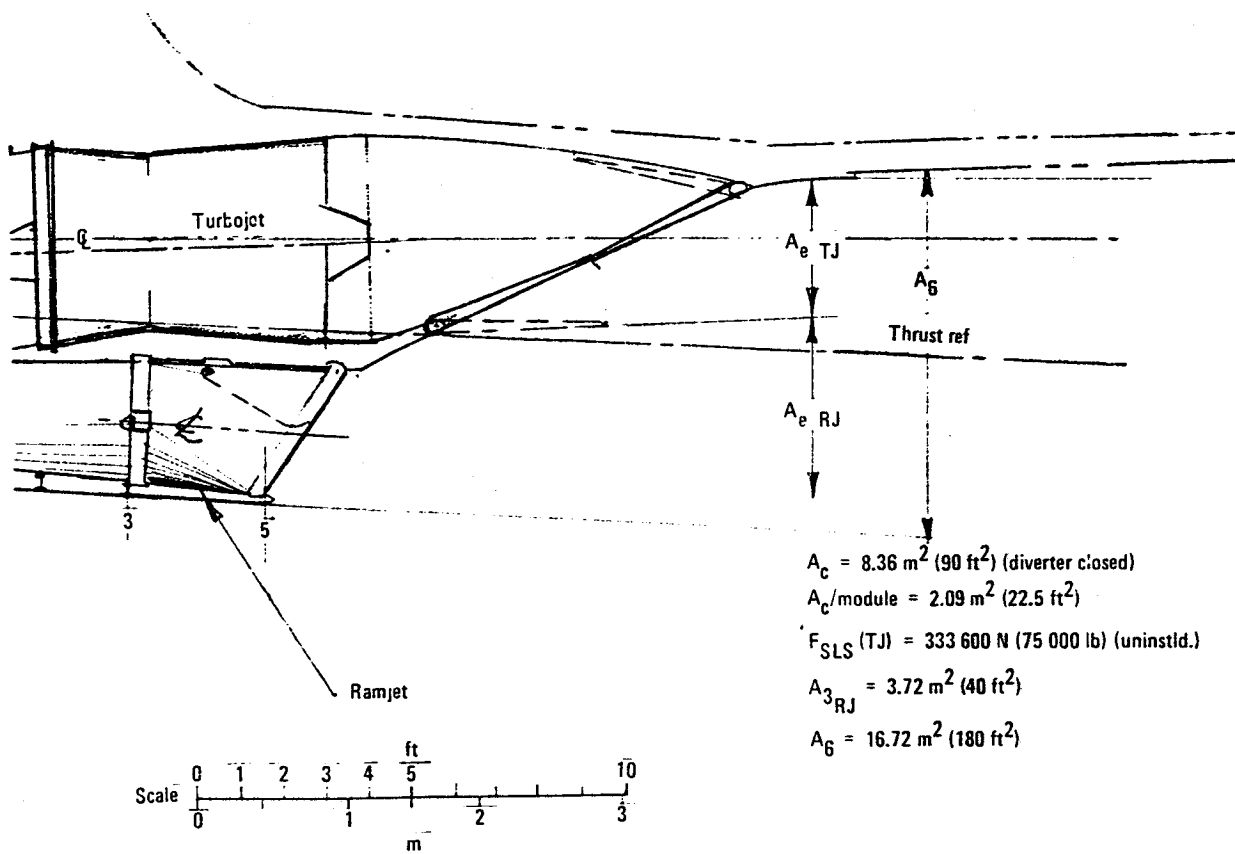

Figure 13. Common Variable - geometry inlet, turbojet-ramjet system schematic.

FOLDOUT FRAME 2

Options in location of the turbojets in relation to the cruise engines and location on the aircraft were examined in the configuration definition phase and were shown in Sect. 3.1.2. The final location of the turbojets adjacent to the cruise engines was dictated, however by the necessity of using a common nozzle for both in order to reduce the base drag of an unfilled nozzle in the critical transonic and low supersonic speed regime. The location on the aircraft was a result of aircraft c.g. requirements and the rotation (scraper angle) required during takeoff and landing.

A detailed description of the installation and performance of both propulsion concepts is presented in Section 3.3 of Volume II.

4. BASIC TECHNOLOGY

4.1 Aerodynamics

Volume II, section 3.1 contains a detailed discussion of the methods, analysis and data on the aerodynamic characteristics and stability of HYCAT-1, -4 and the final revision of HYCAT-1A.

4.2 Aircraft Weight Estimation

Volume II, section 3.4 describes the methods and assumptions used in the airframe weight prediction. Propulsion weights are discussed in Section 3.3 of Volume II.

4.3 Initial Propulsion Data

The turbojet-scrumjet propulsion system was used in the initial screening phase. A detailed discussion of the basis for selection of the turbojet and scumjet engines, data sources and installed performance can be found in Volume II, section 3.2 for this phase of the study.

4.4 Final Propulsion Evaluation

In the final phase the turbojet-scamjet system configuration was revised and performance was recalculated. The major changes were as follows:

- The turbojet inlet and scamjet were located on a ramp to allow concurrent operation of both in the Mach 1.0 to 3.5 region. This also allowed more nozzle area and minimized the volume loss in the fuselage.
- Flow field viscous effects on mass flow were included in the scamjet performance after the turbojet boundary layer diverter was closed at turbojet shutdown.
- The inlet contraction and mass flow ratio schedule was revised to account for the increased external contraction and decreased local Mach number resulting from the ramp.

The installation and performance of the alternate propulsion concept consisting of turbojets with separate modular, subsonic combustion ramjets, both using a common inlet, was provided.

The vehicle flow field, inlet characteristics, installation losses and installed performance of both propulsion systems are described in section 3.3 of Volume II. The weight estimates for both concepts and estimated cooling requirements for the ramjet system are also included in the same section.

5. COMPARATIVE ANALYSIS OF PROPULSION SYSTEMS

As in the initial phase, the hypersonic ASSET program was used in a systematic optimization of the variables of wing loading (W/S), thrust-to-weight ratio (T/W), and capture area to wing size ratio (A_c/S) in all trade-off studies. The criterion for selection was minimum gross weight and the major constraint was the 10,500 ft maximum takeoff or landing field. FAR international fuel reserve requirements were used except that 5% of the fuel used at the end of cruise was used in lieu of 10%. No limitation was placed on airport noise in this study.

5.1 Separate Inlet Turbojet-Scramjet System

The turbojet-scrumjet final optimized point design aircraft selected to perform the Mach 6, 200 passenger, 9260 km (5000 n.mi.) mission is shown in figure 14. In summary, the essential features of this final version compared to the HYCAT-1 of Phase I are:

- Incorporation of a horizontal tail for stability.
- Revision of the propulsion configuration as described in section 3.3 of Volume II.
- Incorporation of the passenger compartment in a double deck, arrangement in the center fuselage.

Table 4 summarizes the geometry, weight and performance characteristics. A listing of selected ASSET program printout pages can be found in Appendix A.

Table 5 is a summary of the unit structural weights based on total planform for wings and tail and wetted area for the fuselage. The thermal protection system weight shown is an average weight. Some of the windward surfaces will require higher weights and leeward less than shown. The thermal protection system could be either an active or a passive type.

5.1.1 Weight sensitivity. - An investigation was made of the selected point design HYCAT-1A to changes in systems, propulsion, or structural weight items. This would occur during final design if for example, the wing weight were to increase 2000 lbs. If the aircraft were to perform the design mission carrying the same payload it would have to be resized. The resulting change in gross weight would be 5.27 kg of gross weight per kg of original weight change, i.e; a "growth factor" of 5.27. Thus the original wing weight increase of 907.2 kg (2000 lb) would cause a gross weight increase of 3656 kg (10 580 lbs) which would involve all non fixed-weight items.

5.1.2 Fuel sensitivity. - The sensitivity to changes in the total fuel load was also investigated. This could be caused, for example, by a degradation during design of propulsion efficiency or a change in reserve fuel requirements. The analysis, using ASSET to resize the aircraft, showed that an original increase of 1 kg of fuel required would cause a 6 kg increase in the gross weight. It is not surprising that this sensitivity or growth factor

TABLE 4. - HYCAT-1A POINT DESIGN CHARACTERISTICS

Turbojet-Scramjet System - 200 passengers

- Mach 6 92.60 km (5000 n.mi.) Range

t/c = 3% $\Lambda_{LE} = 65^\circ$ AR = 1.357

<u>GEOMETRY:</u>				
Wing Ref. Area	m ² (ft ²)		816.8	(8792.1)
Wing Exposed Area	m ² (ft ²)		383.8	(4131.5)
Fus. Length	m (ft)			(388)
Fus. Equivalent Dia.	m (ft)			(24.46)
Fus. Planform Area	m ² (ft ²)		887.1	(9 549)
Fus. Wetted Area	m ² (ft ²)		2 402.1	(25 857)
Scramjet Capture Area	m ² (ft ²)		11.03	(118.7)
Horiz. Tail Total Area	m ² (ft ²)		177.8	
Horiz. Tail Exposed Area	m ² (ft ²)		115.2	
Vertical Tail Area	m ² (ft ²)		90.2	(971)
<u>WEIGHTS:</u>				
		Kg (to)		
Gross Wt.			350 953	(773 706)
Fuel: Block			107 038	(235 975)
Reserve			19 085	(42 074)
Total			126 123	(278 049)
Payload			19 051	(42 000)
Oper. and Std. Items			7 050	(15 542)
Empty Weight			198 729	(438 116)
Structure:			106 026	(233 744)
Wing			24 276	(53 960)
Tail			6 857	(15 117)
Body			41 337	(91 131)
Ldg. Gear			13 023	(28 711)
Surf. Controls			3 046	(6 716)
Thermal Protection			15 407	(33 966)
Nac. and Eng. Sect.			1 852	(4 083)
Propulsion			75 286	(165 974)
Engines (Turbojets)			23 133	(51 037)
Air Inlet (Turbojets)			4 948	(10 909)
Fuel and Oil System			3 281	(7 234)
LH ₂ Tanks, Insul. and Supports			31 531	(69 512)
Eng. Controls and Starter			530	(1 169)
Scram jets			11 845	(26 113)
Furn., Equip. and Subsystems			17 416	(38 396)
<u>PERFORMANCE</u>				
Wing loading	kg/m ²	(lb/ft ²)	429.6	(88)
SLS Thrust/Weight	daN/g	-	0.49	0.50
Capture/Wing area	-	-	0.0135	0.0135
Far takeoff ft dist. (Eng. t)	m	(ft)	2 568	8 426
Cruise L/D (average)	-	-	5.17	5.17
Cruise SFC (average)	kg/hr/daN	(lb/hr/lb)		1.43
Cruise alt.	m	(ft)	29-30175	95-99,000
Far landing dist.	m	(ft)	3 225	10 580
Approach speed	m/s	(keas)	95.7	186
Energy consumption	kJ/seat km	(Btu/seat n.mi)	6 927	12 174

CHARACTERISTICS	WING		HORIZONTAL		VERTICAL
	BASIC	EXPOSED	BASIC	EXPOSED	
AREA (SQ FT)	8792.1	4181.4	1913.5	1239.87	971.03
ASPECT RATIO	1.357		2.0116		1.0
SPAN (FT)	109.23		62.04		31.16
ROOT CHORD (FT)	146.88		43.29		49.03
TIP CHORD (FT)	14.58		12.29		13.29
TAPER RATIO	.099		.2488		.271
MAC (FT)	28.53		34.56		34.58
SWEEP (DEG)	65		55		60
T/C ROOT (%)	3.0		4.0		4.0
T/C TIP (%)	3.0		4.0		4.0

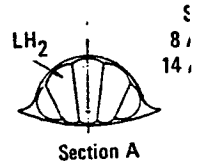
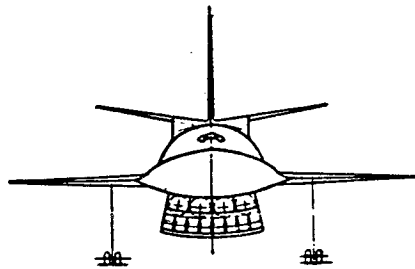
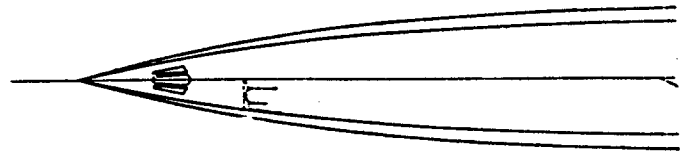

Fwd Tanks 120 987 lbs LH₂

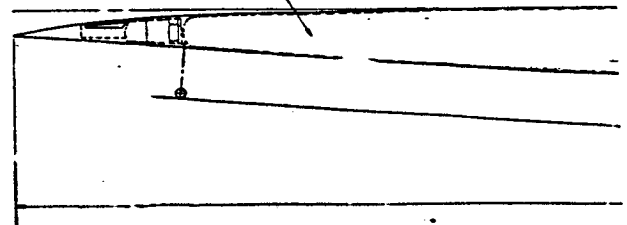

FOLDOUT FRAME

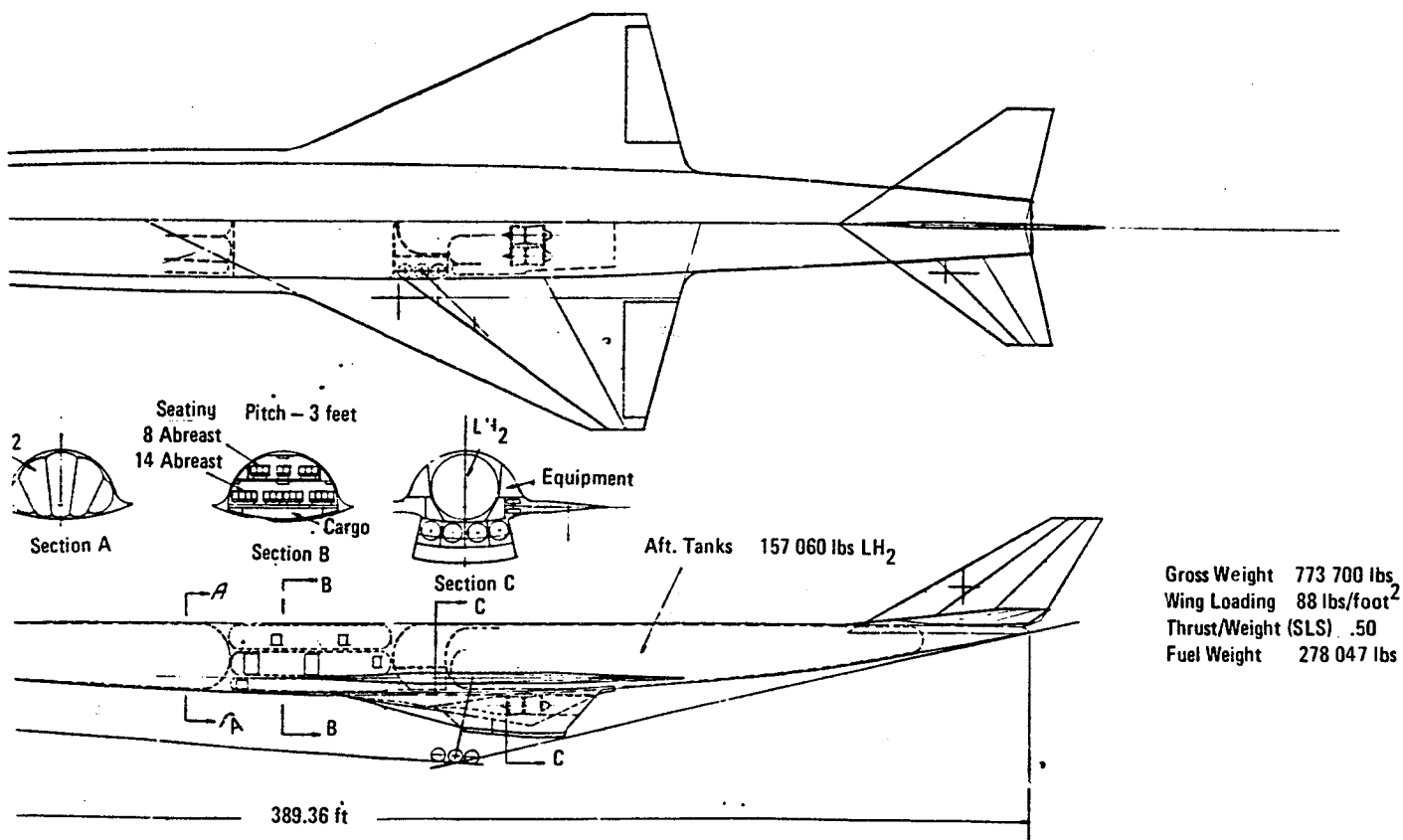

Figure 14. HYCAT-1A, final general arrangement.

EOLDOUT FRAME 2

TABLE 5. - UNIT STRUCTURAL WEIGHTS, HYCAT-1A

Wing	Kg/m ² (lbs/ft ²)	29.97	(6.14)
Horizontal tail		21.97	(4.50)
Vertical tail		32.71	(6.76)
Fuselage (including LH ₂ tanks)		30.37	(6.22)
Thermal protection*	(average)	14.11	(2.89)
*Based on exposed planform areas of wing, tail and fuselage			

is higher than the weight growth factor (above) since it also involves an increase in the fuselage weight to carry the fuel. To further illustrate the above effect, if the propulsion system SFC were anticipated to degrade by 2 percent in service, a not unreasonable assumption, the original gross weight would have to be increased by 15 150 kg (33 400 lb) or the payload decreased by approximately 3130 kg (6900 lb) if the gross weight were not increased and the same range held.



5.1.3 Range sensitivity. - Using the ASSET program to resize the aircraft the original design range of 9260 km (5000 n.mi.) was reduced to 8334 km (4500 n.mi.) and 7408 km (4000 n.mi.), holding the prime constraint of landing field distance constant. The primary effect of course is the reduction in fuel fraction with the secondary one being the decrease in wing loading required to meet the landing distance as the block fuel fraction decreases with range. Table 6 lists some of the characteristics of the aircraft designed for each range. The table shows a growth sensitivity of 136.4 pounds of gross weight per nautical mile between 4000 and 4500 with the sensitivity increasing to 177 between 4500 and 500 nautical miles.

5.1.4 Subsonic cruise range. - If the 9260 km (5000 n.mi.) point design HYCAT-1A (Wg - 350 953 kg (773 706 lb)) were to cruise at subsonic speeds with a full fuel load and the same reserve fuel requirement the maximum range would be 6267 km (3384 n.mi.). The optimum Mach number is 0.90 and the cruise altitude is from 7920 to 8534m (26 000 to 28 000 ft.). The average cruise L/D is 8.31 with an SFC of 0.498 lb/hr/lb which gives us an average range factor (M(L/D)/SFC) of 15 compared to 21.7 for the Mach 6 cruise case. This is not surprising since the subsonic L/D of such an aircraft would not be expected to be high (12-15). Turbojet engine used in the study is also not the best engine for subsonic operation. If an SFC of 0.34, which would be equal to that of turbofan engine could be obtained, the range would approach 9260 km (5000 n.mi.). This of course suggests the dual cycle engine being studied for application in the SCAR program. The range could also be improved by reduction of the propulsion drag in this region.

PRECEDING PAGE BLANK NOT FILMED

TABLE 6a. - POINT DESIGN CHARACTERISTICS OF HYCAT-1A AT RANGES OF 7408, 8334 AND 9260 km (S.I UNITS)

$$T/W = 49 \text{ daN/kg}, \frac{A_c}{S} = .0135, t/c = 3\%, AR = 1.357$$

		Range - km		
		7408	8334	9260
Gross Weight	kg	279 915	310 840	350 953
Fuel: Block		77 893	90 688	107 038
Reserve		15 348	16 974	19 085
Total		93 241	107 662	126 123
Payload		19 051	19 051	19 051
Oper. and Std. Items		6 240	6 595	7 050
Empty Weight		152 312	177 531	178 729
Structure		85 690	94 420	106 026
Propulsion		59 099	66 157	75 286
Furn. Equip. and Systems		16 594	16 954	17 385
Fus. Length	m	103.33	110.03	118.26
Wing Loading	kg/m ²			
Cruise L/D	-	4.97	5.06	5.17
Cruise Alt.	m	29.3-30 180	28.96-30 180	28.96-30 180
Far T.O. Dist	m	2 444	2 509	2 568
Far Ldg. Dist.	m	3 158	3 179	3 225
Approach Speed	m/g	94.4	95.0	95.7
Block Time	hr	1.95	2.08	2.21
Energy Consumption	kJ/seat km	6 301	6 521	6 927
Growth Sensitivity	$\frac{\text{kg (Wg)}}{\text{km}}$			
		33.41		43.33

5.2 Common Variable Geometry Inlet, Turbojet-Ramjet Systems

The approach used in the design optimization of the turbojet-ramjet propulsion system consisted of replacing the turbojet-scrumjet system with the weight and performance characteristics of the turbojet-ramjet system using the selected point design scumjet aircraft described above 350 953 kg (773 706 lb). This was done to obtain a "side by side" comparison of the weights and fuel consumption for each system in the same configuration. Both aircraft have a thrust-to-weight of 0.50 and a wing loading of 429.6 kg/m² (88 lb/ft²). The only difference is that while the scumjet had an optimized

TABLE 6b. - POINT DESIGN CHARACTERISTICS OF HYCAT-1A AT RANGES OF 4000, 4500, AND 5000 N.MI. (CUSTOMARY UNITS)

$$T/W = .50, \frac{A_c}{S} = .0135, t/c = 3\%, AR = 1.357$$

		Range - n.mi.		
		4000	4500	5000 (REF.)
Gross Weight	lb	617 097	685 273	773 706
Fuel: Block		171 720	199 930	235 975
Reserve		33 837	37 421	42 074
Total		205 557	237 351	278 049
Payload		42 000	42 000	42 000
Oper. and Std. Items		13 757	14 540	15 542
Empty Weight		355 784	391 383	438 116
Structure		188 912	208 158	233 744
Propulsion		130 289	145 848	165 974
Furn. Equip. and Systems		36 583	37 377	38 326
Fus. Length	ft	339	361	388
Wing Loading	lb/ft ²	82	85	88
Cruise L/D	-	4.97	5.06	5.17
Cruise Alt.	ft	96-99 000	95-99 000	95-99 000
Far takeoff dist.	ft	8 017	8 230	8 426
Far landing dist.	ft	10 362	20 430	10 580
Approach Speed	keas	183.5	184.7	186
Block Time	hr	1.95	2.08	2.21
Energy Consumption	Btu/seat nm	11 074	11 461	12 174
Growth Sensitivity	$\frac{\text{lb (Wg)}}{\text{n.mi.}}$	136.4		176.9

capture-to-wing area ratio of 0.0135 ($A_c = 11.03 \text{ m}^2 (118.7 \text{ ft}^2)$), the ramjet system A_c/S ratio selected was 0.01275 based on obtaining the same net thrust as the scramjet at turbojet shutdown. The ASSET program was not allowed to size the aircraft but simply flew the airplane through the mission holding the takeoff gross weight constant.

A summary of the weight output is shown in table 7. Inspection of the table shows that the equipment, structural, standard, and operating weight items are almost identical, but that the propulsion system is 466 kg (10293 lb) lighter. This is due primarily to that fact that the turbojet-scamjet requires a separate inlet for the turbojet.

TABLE 7a. - WEIGHT BUILD-UP COMPARISON OF TURBOJET-RAMJET SYSTEM INSTALLED IN TURBOJET-SCRAMJET POINT DESIGN AIRCRAFT (S.1 UNITS)

$$T/W = .49 \text{ daN/kg} \quad W/S = 118.26 \text{ kg/m}^2 \quad A_c/S = .0135 \text{ (SJ), } 0.01275 \text{ (RJ)}$$

	kg	TJ-SJ	TJ-RJ	ΔW (SJ-RJ)
<u>Equipment</u>		17 417	17 427	-10
<u>Structure</u>		(106 026)	(106 534)	-508
Wing		24 476	24 476	
Tail		6 403	6 734	
Body		41 364	42 075	
Ldg. Gear		13 023	13 023	
Surf. Controls		3 046	3 046	
Nac. & Eng. Sect.		1 852	1 773	
Thermal Protec.		15 407	15 407	
<u>Propulsion</u>		(75 285)	(70 616)	4669
Engines		23 150	22 163	
Inlet		4 948	9 407	
Fuel Tanks		31 531	32 545	
Fuel and Oil System		3 282	2 304	
Eng. Contr. & Starter		530	508	
Scramjets/Ramjet		11 844	1 690	
<u>Empty Weight</u>		198 729	194 578	
<u>Std. & Oper. Items</u>		7 050	7 145	-95
<u>Payload</u>		19 051	19 051	
<u>Fuel Wt. Available</u>		126 122	130 179	-4057
<u>Gross Weight</u>		350 953	350 953	

A weight advantage of 987 kg (2176 lb) is also shown for the Mach 3.5 turbojet used with the ramjet vs the Mach 4.0 turbojet required with the scramjet system. The significant end result of the weight build-up is that the ramjet system has an advantage of being able to carry a fuel load 4057 kg (8944 lb) more than the scramjet system. Note that the higher body, lower tail, and higher tank weights of the ramjet system are due to the longer body required to contain this extra fuel weight.

A comparison of the mission fuel consumption is shown in table 8. The right hand column shows that the advantage in fuel consumption is 6804 kg (15 000 lbs) of block and 2223 kg (4900 lb) of reserve fuel for the ramjet system. The difference during climb and descent is mainly due to the lower transonic propulsion installation drag and higher specific impulse of the ramjet system (See Section 5.3). The descent fuel flow of the scramjet could be decreased at the expense of the descent range due to the higher propulsion

TABLE 7b. - WEIGHT BUILD-UP COMPARISON OF TURBOJET-RAMJET SYSTEM INSTALLED IN TURBOJET-SCRAMJET POINT DESIGN AIRCRAFT (CUSTOMARY UNITS)

T/W = .50 W/S = 88 $A_c/S = .0135$ (SJ), 0.01275 (RJ)

Equipment	lb	TJ-SJ	TJ-RJ	ΔW (SJ-RJ)
Equipment		(38 398)	(38 423)	-22
Structure		(233 743)	(234 864)	-1121
Wing		53 960	53 960	
Tail		14 117	14 845	
Body		91 190	92 757	
Ldg. Gear		28 711	28 711	
Surf. Controls		6 716	6 716	
Nac. & Eng. Sect.		4 083	3 909	
Thermal Protec.		33 966	33 966	
Propulsion		(165 973)	(155 680)	10 293
Engines		51 036	48 860	
Inlet		10 909	20 738	
Fuel Tanks		69 512	71 748	
Fuel and Oil System		7 235	7 284	
Eng. Contr. & Starter		1 169	1 120	
Scramjets/Ramjet		26 112	5 930	
Empty Weight		438 114	428 964	
Std. & Oper. Items		15 542	15 752	-210
Payload		42 000	42 000	
Fuel Wt. Available		278 047	286 991	-8 944
Gross Weight		773 706	773 706	

drag which would result as explained in Section 4.2.1.6. Again the reserve fuel advantage is due to the lower propulsion drag of the ramjet system during the subsonic cruise. During the cruise portion of the mission something of an anomaly occurs in that while the specific impulse of the ramjet is 3008 sec., that of the scramjet is only 2518 sec. (16.3% lower); however, the specific range of the scramjet vehicle is only 2.1 percent lower. A small part of this is due to the higher average gross weight (1.97%) of the ramjet aircraft in cruise but the major difference is in the propulsion-aero force accounting. As was pointed out in Section 4.2.1, the turbojet inlet and the scramjet are mounted on a ramp to allow concurrent operation of both. Thus the "propulsion system" includes this ramp even when the turbojet inlet is closed. Except for the turbojet inlet, the ramp forces would have normally been included in the aerodynamic forces but are all charged to propulsion resulting in the apparent low specific impulse of the scramjet. The ramp forces in cruise are included in the spillage drag and lift as well as the smaller spillage drag and lift forces of the scramjet inlet itself.

TABLE 8a. - COMPARISON OF MISSION FUEL CONSUMPTION OF TURBOJET-RAMJET SYSTEM
 INSTALLED IN POINT DESIGN TURBOJET-SCRAMJET AIRCRAFT (S.1 UNITS)

T/W = .49 daN/kg W/S = 118.26 Ng/m² Ac/S = 0.0135 (SJ), 0.01275 (RJ)

		TJ-SJ	TJ-RJ	ΔW_{FUEL} (SJ-RJ)
Block Fuel	<u>Gross Wt. (Takeoff)</u> kg	350 953	350 953	
	<u>Takeoff & Climb to M6.0:</u>			
	Opt. Cruise Alt m	29 - 302.00	27.4 - 28.400	
	Fuel Used kg	48 737	44 749	3 988
	Dist. km	2 008	2 069	
	<u>Cruise</u>			
	L/D -	5.17	5.20	
	ISP* daN/kg/sec	2 469	2 950	
	Fuel Used kg	54 324	52 840	1 484
	Dist. km	6 091	6 052	
	km/kg	.1121	.1145	
	<u>Descent: (M6.0 to 128.6 m/g)</u>			
	Fuel Used kg	2 938	1 638	1 300
	Dist. km	1 161	1 141	
<u>Air Maneuver & Ldg:</u>				
Fuel Used kg	1 039	987	52	
<u>Total Block Fuel</u>	107 038	100 214	6 824	
Reserve Fuel (Subsonic)	<u>Contingency Fuel:</u>			
	5% of Block Fuel kg	5 352	5 011	341
	<u>Climb</u>			
Fuel Used kg	3 214	2 962	252	
Dist. km	50	44		
Reserve Fuel (Subsonic)	<u>Cruise</u>			
	Fuel Used kg	4 705	3 388	1 317
	Dist. km	369	362	
	<u>Descent</u>			
	Fuel Used kg	94	105	-11
	Dist. km	65	74	
	<u>30 Min. Loiter & Ldg.</u>			
Fuel Used kg	5 722	5 418	304	
<u>Total Res. Fuel</u> kg	19 086	16 883	2 203	
<u>Total Mission Fuel</u> kg		126 124	117 097	9 027
*Defined as net thrust in flight axis direction divided by total fuel hold				

TABLE 8b. - COMPARISON OF MISSION FUEL CONSUMPTION OF TURBOJET-RAMJET SYSTEM
 INSTALLED IN POINT DESIGN TURBOJET-SCRAMJET AIRCRAFT
 (CUSTOMARY UNITS)

T/W = 0.5 W/S = 88 Ac/S = 0.0135 (SJ), 0.01275 (RJ)

		TJ-SJ	TJ-RJ	ΔW_{FUEL} (SJ-RJ)	
Block Fuel	<u>Gross Wt. (Takeoff) - lb</u>	773 706	773 706		
	<u>Takeoff & Climb to M6.0:</u>				
	Opt. Cruise Alt	ft	95-99 000	90-93 000	
	Fuel Used	-lb	107 444	98 653	8 791
	Dist.	n.mi.	1 084	1 117	
	<u>Cruise</u>				
	L/D	-	5.17	5.20	
	ISP*	sec.	2 518	3 008	
	Fuel Used	lb	119 763	116 490	3 273
	Dist.	n.mi.	3 289	3 268	
	NM/lb		0.02746	0.02805	
	<u>Descent: (M6.0 to 250 kts):</u>				
	Fuel Used	lb	6 478	3 611	2 867
Dist.		627	616		
<u>Air Maneuver & Ldg:</u>					
Fuel Used	lb	2 290	2 176	114	
<u>Total Block Fuel</u>		235 975	220 930	15 045	
Reserve Fuel (Subsonic)	<u>Contingency Fuel:</u>				
	5% of Block Fuel	lb	11 799	11 046	753
	<u>Climb</u>				
Fuel Used	lb	7 085	6 529	556	
Dist.	n.mi.	27	24		
Reserve Fuel (Subsonic)	<u>Cruise</u>				
	Fuel Used	lb	10 373	7 470	2 903
	Dist.	n.mi.	199	196	
	<u>Descent</u>				
	Fuel Used	lb	208	232	-24
	Dist.	n.mi.	35	40	
	<u>30 Min. Loiter & Ldg.</u>				
Fuel Used	lb	12 614	11 945	669	
<u>Total Res. Fuel</u>	lb	42 076	37 220	4 856	
<u>Total Mission Fuel</u>	lb	278 051	258 150	19 901	
*Defined as net thrust in flight axis direction divided by total fuel flow					

The final result is that while the scramjet is charged with a higher spillage drag it also provides a very high spillage lift contribution to the aircraft. This is shown in the table 9 comparison of the ramjet and scramjet baseline aircraft, each cruising at its optimum altitude. The final result is a slight advantage of 4 percent in specific range for the ramjet system which is partially negated by the 1.97 percent higher average cruise weight of the ramjet aircraft.

TABLE 9a. - BASELINE AIRCRAFT CRUISE COMPARISON OF THE TURBOJET-RAMJET AND THE TURBOJET-SCRAMJET SYSTEM (S.I. UNITS)

$$T/W = .49 \frac{\text{daN}}{\text{kg}} \quad W/S = 118.26 \text{ kg/m}^2 \quad W_g = 350\,953 \text{ kg}$$

$$A_{c_{SJ}} = 11.03 \text{ m}^2 \quad A_{c_{RJ}} = 10.41 \text{ m}^2$$

		TJ-SJ	TJ-RJ
①	Cruise wt.	286 339	285 792
	Cruise Alt.	29 261	27 737
	Cruise L/D	5.18	5.2
	Angle of attack	0.0745	0.0675
②	Centrifugal lift	14 889	14 760
	Propulsion:		
	β (Gross Thrust deflection)	0.0873	0.0873
	Capture area	11.03	10.41
	Gross Thrust	187 772	178 951
	Inlet drag	540	2 747
	Momentum drag	134 411	125 162
	Spillage Drag	3 030	0
	Spillage lift	41 287	0
③	Total Propulsion Lift	52 012	18 837
④	Aero. Lift Req'd. = ① - ② - ③	219 529	252 188
	Aero. Drag - ④ / L/D	42 381	48 456
	Net Thrust in Flt. Axis	42 381	48 456
	Fuel Flow	16.833	16.107
	$I_{sp} = \frac{\text{Net Thrust}}{\text{Fuel Flow}}$	2 469	2 950
	Specific Range -	0.1074	0.1118

TABLE 9b. - BASELINE AIRCRAFT CRUISE COMPARISON OF THE TURBOJET-RAMJET AND THE TURBOJET-SCRAMJET SYSTEM (CUSTOMARY UNITS)

T/W = 0.5 W/S = 88 Wg = 773 706 lb

$A_{CSJ} = 118.7 \text{ ft}^2$

$A_{CRJ} = 112.1 \text{ ft}^2$

		TJ-SJ	TJ-RJ
①	Cruise Wt. -lbs	631 258	630 053
	Cruise Alt. ft	96 000	91 000
	Cruise L/D	5.18	5.2
	Angle of attack deg	4.27	3.87
②	Centrifugal lift -lb	32 823	32 540
	Propulsion:		
	β (Gross Thrust deflection) -deg	5	5
	Capture area ft^2	118.7	112.1
	Gross Thrust -lb	413 960	392 750
	Inlet drag	1 190	6 656
	Momentum drag	296 320	275 930
	Spillage Drag	6 680	0
	Spillage lift	91 020	0
③	Total Propulsion Lift	114 664	41 528
④	Aero. Lift Req'd. = ① - ② - ③	483 970	555 970
	Aero. Drag - ④ /L/D	93 432	106 825
	Net Thrust in Flt. Axis	93 432	106 825
	Fuel Flow lb sec	37.11	35.51
	$I_{sp} = \frac{\text{Net Thrust}}{\text{Fuel Flow}}$ sec	2 518	3 008
	Specific Range - n.mi./lb	0.0263	0.02739

Following a checkout of the performance and weight of the baseline aircraft described above, the synthesis program was allowed to size the turbojet-ramjet aircraft to provide the design range capability of 9260 km (5000 n.mi.) for a matrix of various thrust-to-weights, capture areas, and wing loadings. The minimum gross weight aircraft that meets the landing field distance constraint was then selected. A summary of this point design is shown in table 10. As anticipated from the lower propulsion weight and fuel consumption of the ramjet system, the gross weight shows a 72 576 kg (160 000 lb) reduction compared to the scramjet system. A lower wing loading was required to meet the landing field length constraint because of the reduced block fuel fractions.

5.3 Comparison of Separate Inlet and Common Inlet Systems

The cause of the difference in the point design gross weights of the optimized scramjet and ramjet systems can best be shown as in table 11 expressed in terms of weight fractions. As can be seen items such as payload, operating items, furnishings and subsystems tend to remain constant in weight and as a result, increase in weight fraction as gross weight decreases. The structural fraction remains almost constant with the major change being in the propulsion and fuel weight fractions which decrease by 1.86 and 1.06 percent of gross weight respectively for the ramjet system. This is a total reduction of 2.92 percent and using the weight sensitivities given in Sections 5.5.1 and 5.5.2 one could have predicted that the final gross weight would be in the 272-283 500 kg (600-625 000 lb) range.

The most significant actual causes for this weight decrease are the reduced propulsion weight and fuel consumption of the ramjet system. As already stated, the low speed propulsion installation drag of the scramjet system is the most important single factor. This is shown by a comparison of the mission climb history shown in figure 15 for the turbojet-scramjet systems compared to figure 16 for the turbojet-scramjet at the same gross weight. The thrust-drag pinch points occur in the Mach 1-1.5 region and at the end of turbojet operation. The higher installation drag of the scramjet in the transonic region is shown as is the lower thrust at the end of turbojet operation (Mach 4 to 5). It should be explained that the initial intent was to terminate turbojet operations at Mach 3.5 but it was found that a deficiency in the thrust available from the scramjet occurred at the end of turbojet operation. Two alternatives were considered: 1) increasing the capture area by approximately 20% or 2) extending the turbojet operation to Mach 4. The first solution is undesirable because of the weight penalty of 2268 kg (5,000 lb) involved. The second alternative was selected and the performance envelope of the turbojet extended to Mach 4 by assuming that the turbojet airflow would be reduced at Mach 4 so that the turbojet inlet would not

TABLE 10. - HYCAT-1A POINT DESIGN CHARACTERISTICS

Turbojet-Ramjet System

- Mach 6
- 9260 km (5000 n.mi) range

t/c = 3%

$\Lambda_{LE} = 65^\circ$

AR = 1.357

<u>Geometry:</u>			
Wing Ref. Area	m ² (ft ²)	662.4	(7 129.9)
Wing Exposed Area	m ² (ft ²)	280.4	(3 018.2)
Fus. Length	m (ft)	105.1	(344.9)
Fus. Equivalent Dia.	m (ft)	7.46	(24.46)
Fus. Planform Area	m ² (ft ²)	735.7	(7 919)
Fus. Wetted Area	m ² (ft ²)	2 043.5	(21 997)
Inlet Capture Area	m ² (ft ²)	8.12	(87.4)
Horiz. Tail Total Area	m ² (ft ²)	146.8	(1 580)
Horiz. Tail Exposed Area	m ² (ft ²)	90.49	(974)
Vertical Tail Area	m ² (ft ²)	74.49	(801.8)
<u>Weights:</u>			
Gross Wt.	kg (lb)	278 136	(613 174)
Fuel: Block		83 778	(184 696)
Reserve		13 236	(29 179)
Total		97 014	(213 875)
Payload		19 051	(42 000)
Oper. and Std. Items		6 328	(13 951)
Empty Weight		155 743	(343 349)
Structure:		(84 682)	(186 688)
Wing		18 199	(40 121)
Tail		5 661	(12 481)
Body		33 870	(74 670)
Ldg. Gear		10 839	(23 895)
Surf. Controls		2 497	(5 505)
Thermal Protection		12 210	(26 918)
Nac. and Eng. Sect.		1 405	(3 098)
Propulsion		(54 476)	(120 098)
Engines (Turbojets)		17 428	(38 722)
Air Inlet		7 339	(16 179)
Fuel and Oil System		2 831	(6 242)
LH ₂ Tanks and Insul. and Supports		24 254	(53 469)
Eng. Controls and Starter		402	(887)
Ramjets		2 096	(4 620)
Furn., Equip and Subsystems		16 585	(36 563)

TABLE 10. - HYCAT-1A POINT DESIGN CHARACTERISTICS (Cont'd)

Performance				
Wing Loading	kg/m ²	(lb/ft ²)	419.9	(86)
SLS Thrust/Weight	daN/kg	-	0.49	(0.56)
Capture/Wing Area	-	-	0.01225	(0.01225)
Far T.O. Dist. (Eng. Out)	m	(ft)	2 557	(8 390)
Cruise L/D (Average)	-	-	4.93	(4.93)
Cruise SFC (Average)	kg Av	daN (lb/lb)	1.218	(1.194)
Cruise Alt.	m	(ft)	27.4-28 650	(90-94 000)
Far Landing Dist.	m	(ft)	3 172	(10 406)
Approach Speed.	m/s	(knots)	94.9	(184.5)
Energy Consumption	kj seat km	(Btu/ seat n.mi.)	5 422	(9 529)

have to be larger than at Mach 3.5. Because of the higher operating pressure and temperature however, the weights of the inlet and turbojet were increased 4.56 and 4.46% respectively. The final specific weight of the turbojet inlet, including boundary layer and retraction mechanism is 595.6 kg/m² (122 lbs/ft²) and the sea level uninstalled static thrust-to-weight of the turbojet is 7.58 (assumed constant with size).

The final result is an increase in the climb fuel required for the scramjet system of 48 737 kg (107 444 lb) compared to 44 740 kg (98 633 lb) for the turbojet system. In order to isolate this effect, the scramjet aircraft was resized by making the assumption that the total propulsion installation drag of the scramjet system was exactly equal to that of the ramjet system. The results of this assumption are shown in the third column of table 11 which indicates a dramatic weight reduction of almost 36298 kg (80 000 lb).

5.4 Turbojet-Ramjet System With Fixed Diverter

The previous analysis of the turbojet-ramjet system assumed that the variable-geometry inlet and ramjet combustor could function while ingesting the fuselage boundary layer in the Mach 3.5 to 6 region (diverter closed). Since this assumption cannot be established short of test validation, an analysis was made to determine the effect on propulsion characteristics and aircraft weight of a fixed diverter. The diverter was a vee-shaped ramp designed to plow off the maximum boundary layer displacement thickness. The effect of the diverter was to increase the inlet recovery by decreasing the viscous losses in total pressure and to increase the mass flow by removing the displacement thickness. The disadvantages are an increase in drag and

TABLE 11. - WEIGHT FRACTION COMPARISON - POINT DESIGN,
SCRAMJET AND RAMJET SYSTEMS

Gross Weight (Ref.) - kg (lbs)	TJ - SJ	TJ - RJ	Low Drag TJ - SJ*
		350 953 (773 706)	278 136 (613 174)
Fractions:			
Payload	0.0543	0.0685	0.0604
Std. and Oper. Items	0.0200	0.0228	0.0211
Furn., Equip. and Systems	0.0496	0.0596	0.0539
SUBTOTAL	(0.1239)	(0.1509)	(0.1354)
Structure	0.3021	0.3045	0.3030
Propulsion	0.2145	0.1959	0.2129
Fuel:			
Takeoff and climb	0.1390	0.1504	0.1336
Cruise	0.1548	0.1437	0.1574
Descent and landing	<u>0.0113</u>	<u>0.0071</u>	<u>0.0119</u>
Total Block	(0.3051)	(0.3012)	0.3029
Reserve	<u>0.0544</u>	<u>0.0476</u>	<u>0.0458</u>
Total Fuel	(0.3594)	(0.3488)	0.3487
Propulsion plus Fuel Fraction	0.5739	0.5447	0.5615
*With propulsion installation drag below Mach 2 equal to turbojet-ramjet system.			

weight. The installed performances compared to the retracted diverter is shown in Figures 17, 18, and 19 which indicate an increase in thrust but a decrease in specific impulse in the Mach 4 to 6 region both in full power and part power cruise at Mach 6 as shown in Figure 19.

A weight penalty was caused by the increase in total pressure recovery which increased the inlet weight by 11.3% and the ramjet module weight by 11.9%. A further penalty was caused by the fixed diverter, the surfaces of which were assumed to consist of a metallic heat shield over high temperature insulation. This penalty was partially offset by the removal of the retractable diverter panels and actuators. The final specific weight comparison is:

	Retractable Diverter		Fixed Diverter	
	kg/m ² of Ac	(lb/ft ² of Ac)	kg/m ² of Ac	(lb/ft ² of Ac)
Inlet Specific Wt.	903.1	(185)	1045.7	(214.2)
Ramjet Specific Wt.	<u>258.3</u>	<u>(52.9)</u>	<u>289.0</u>	<u>(59.2)</u>
Total Specific WT.	1161.4	237.9	1334.7	(273.4)

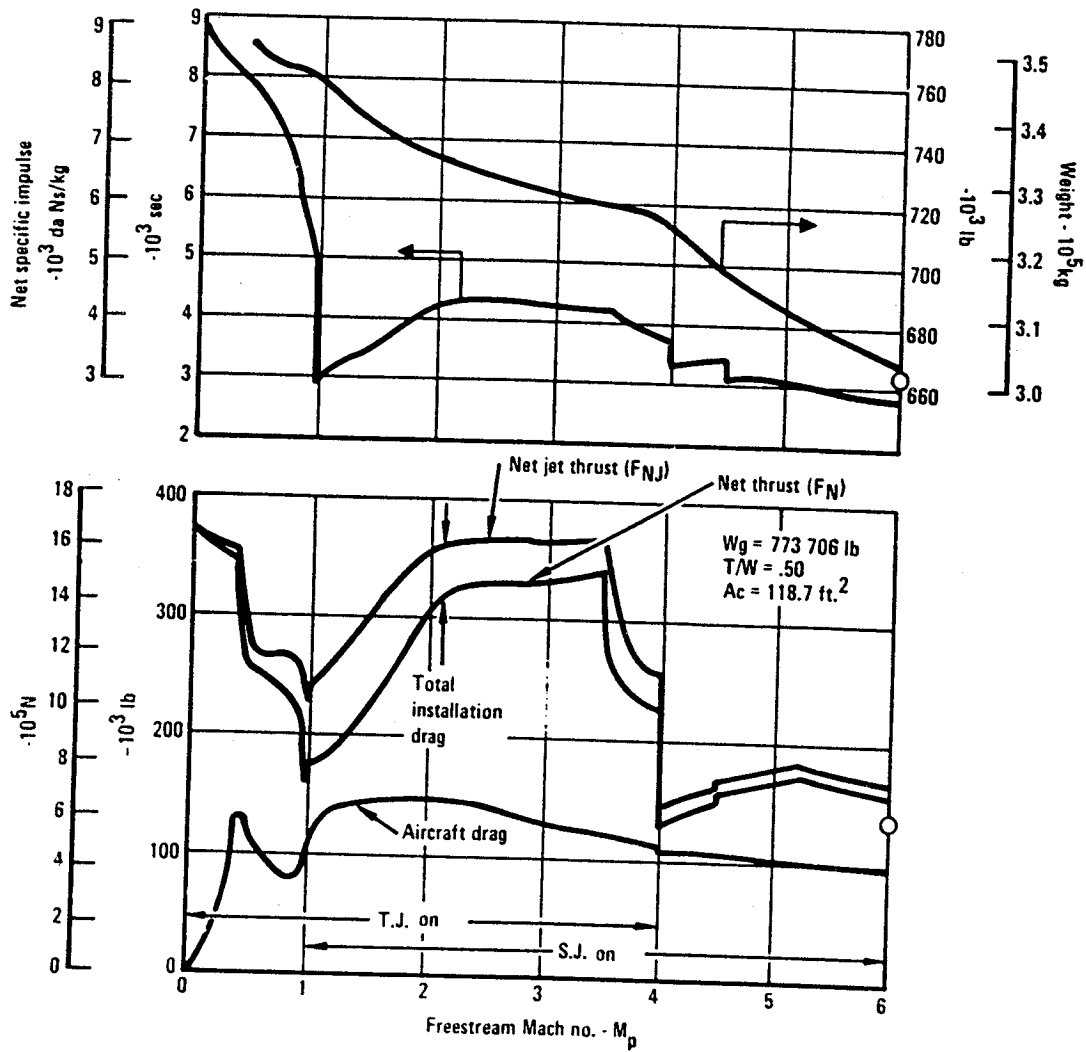

Figure 15. Mission climb history, turbojet-scamjet system.

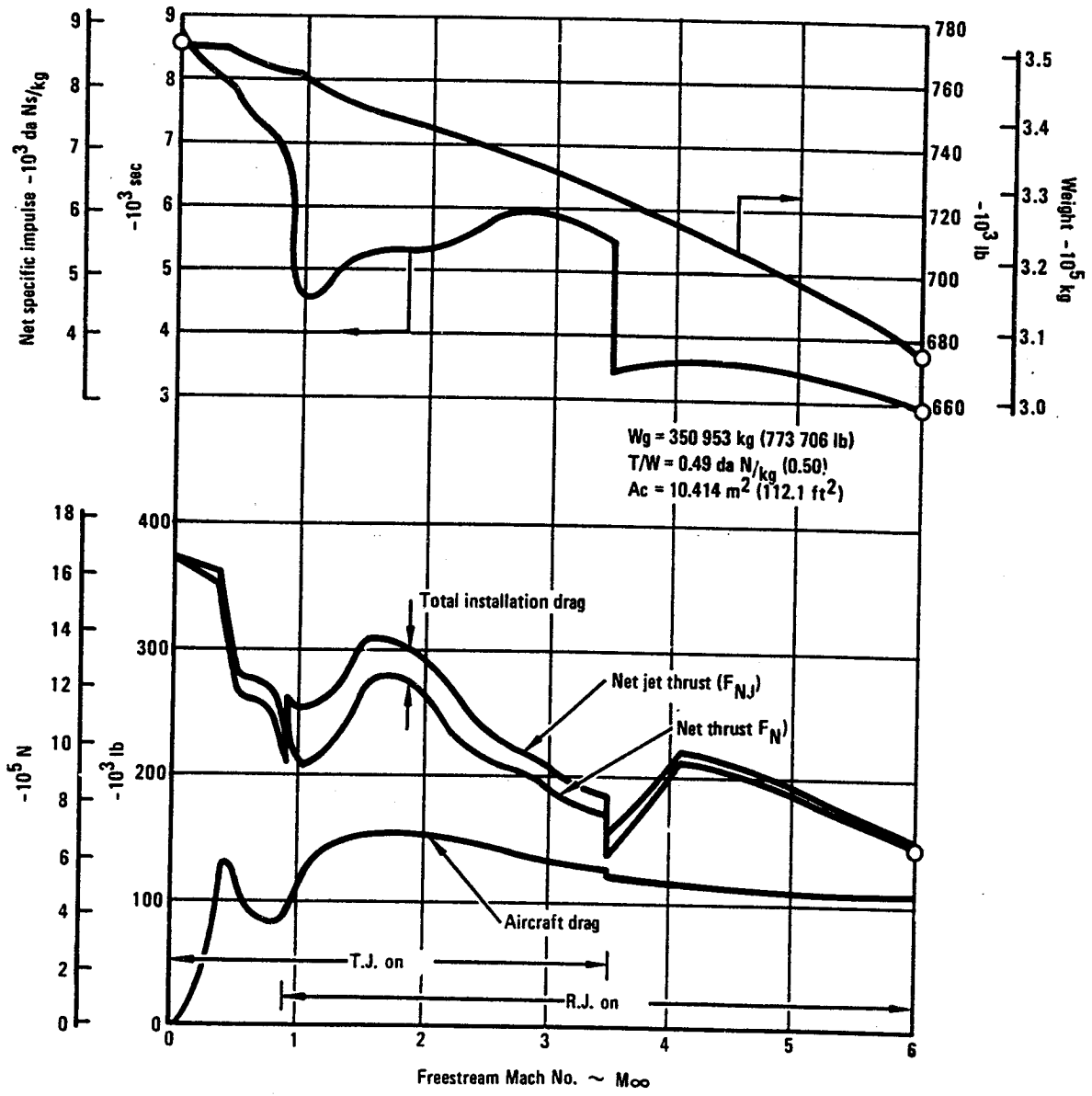

Figure 16. Mission climb history, turbojet-ramjet system.

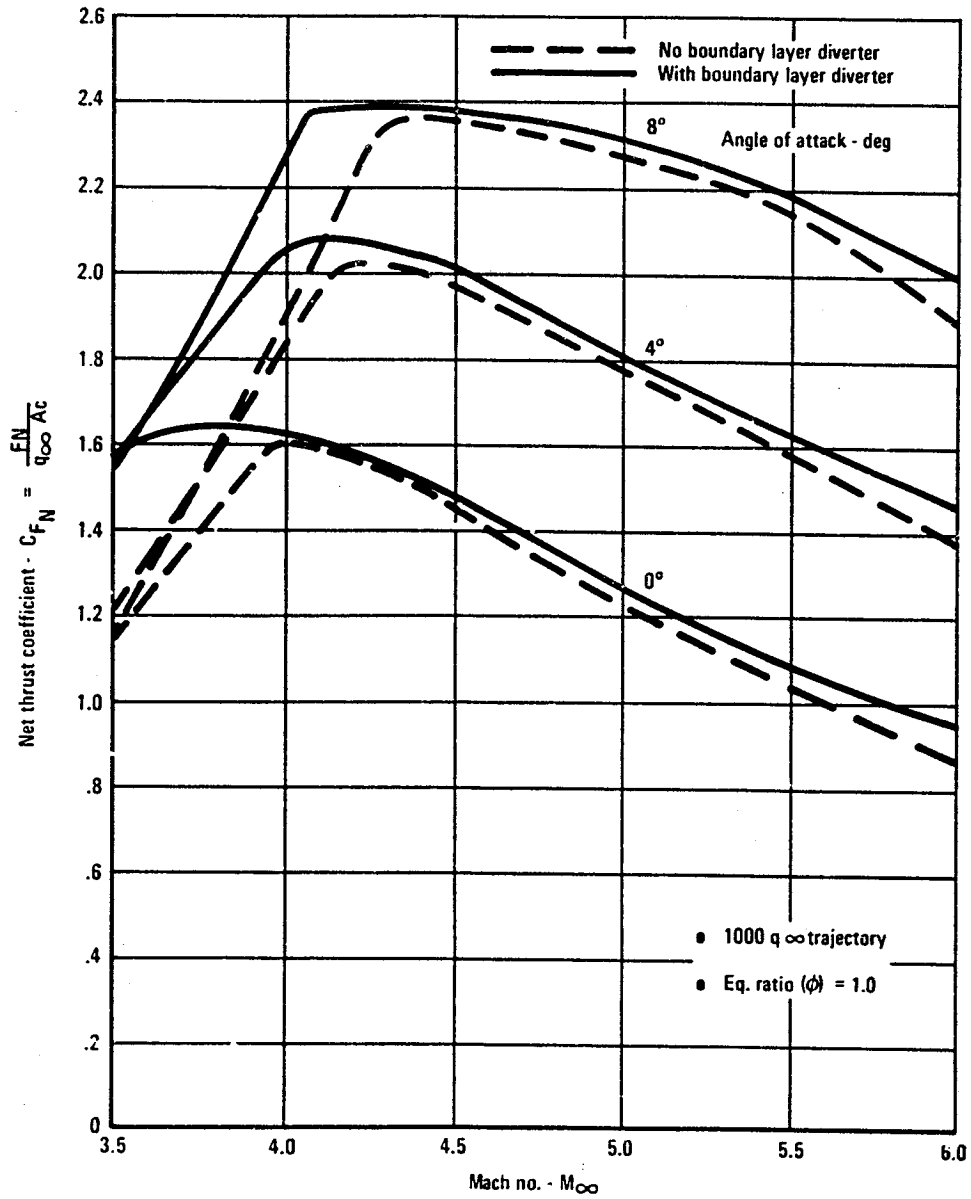

Figure 17. Installed thrust coefficient ramjet with fixed diverter.

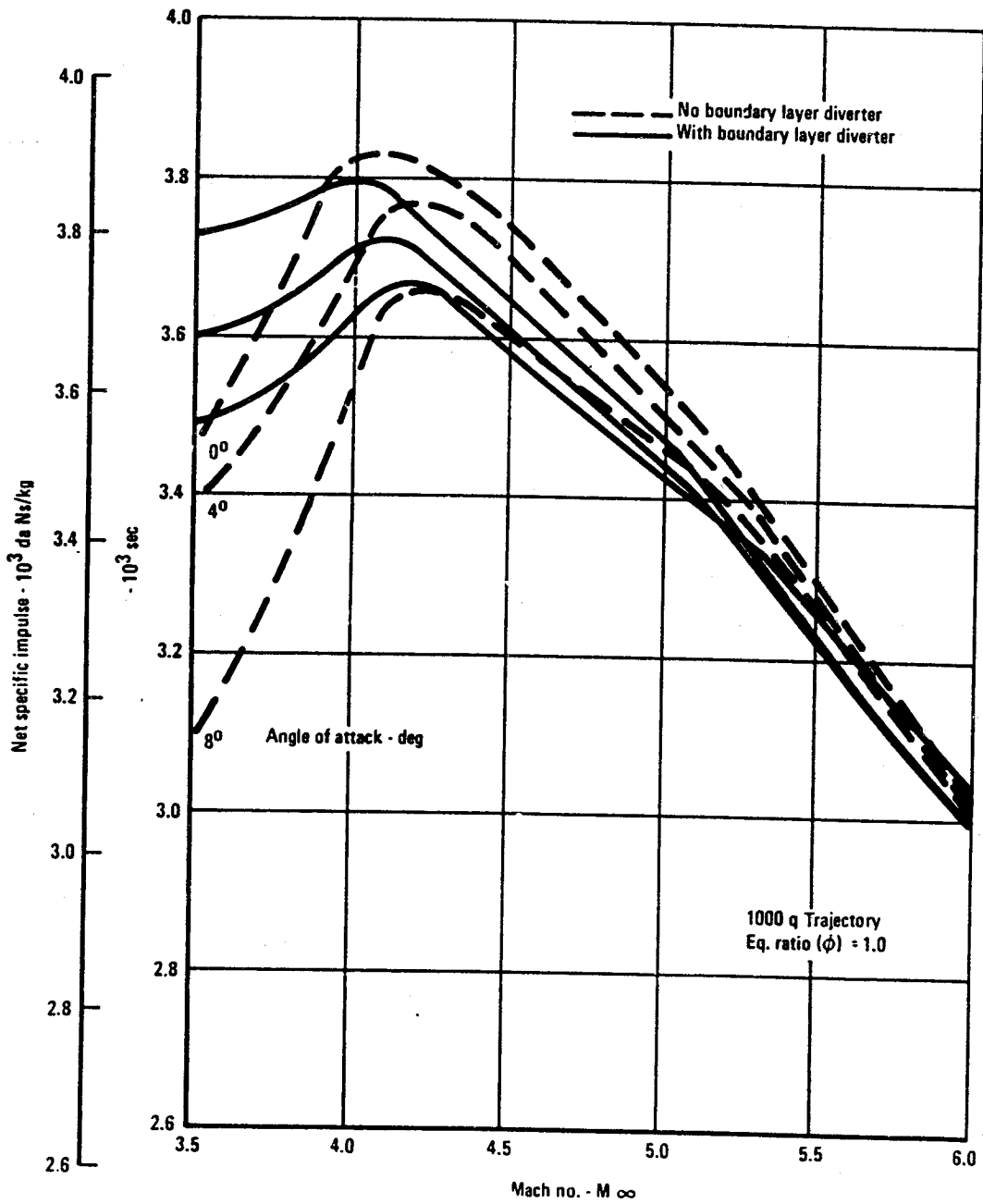

Figure 18. Installed specific impulse ramjet with fixed diverter.

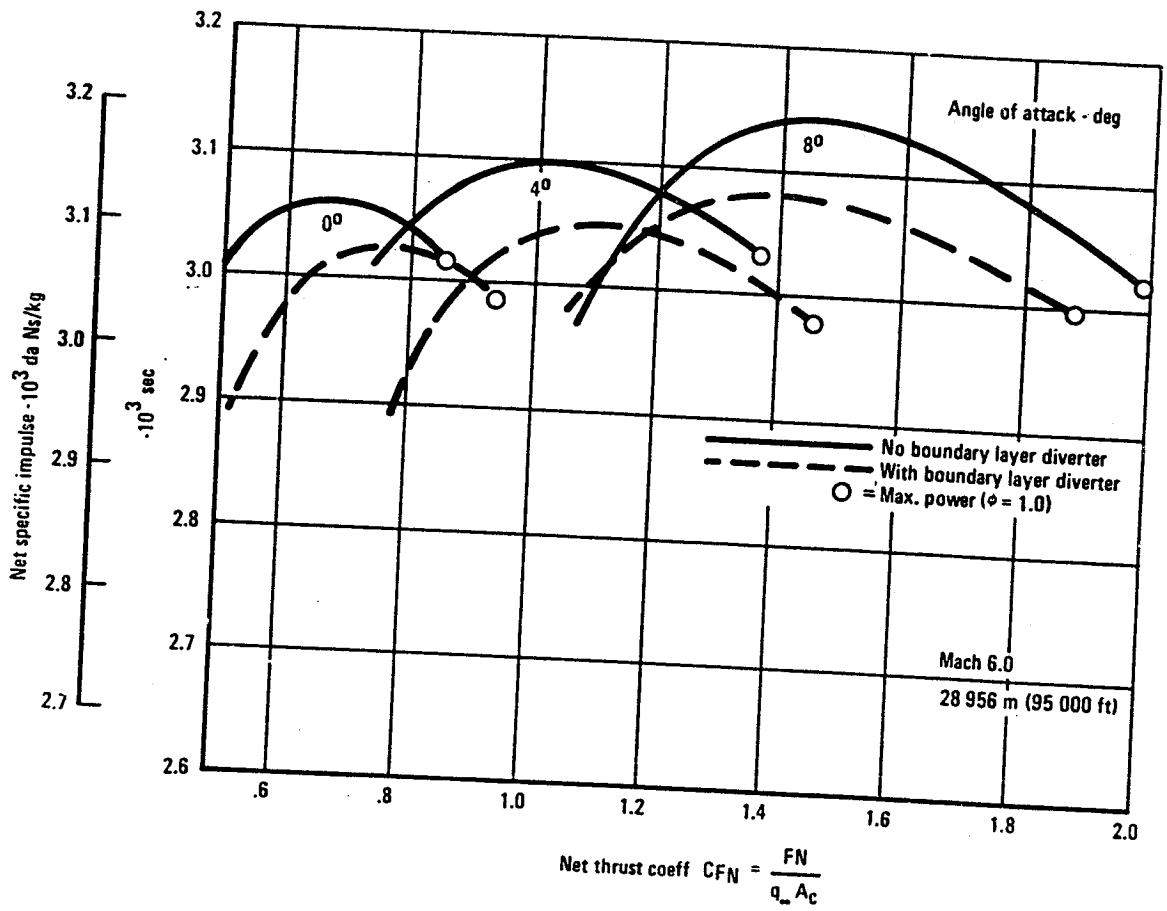

Figure 19. Cruise part power performance - ramjet with fixed diverter.

The final diverter propulsion characteristics and new weight were incorporated into the ASSET vehicle synthesis program and the aircraft (HYCAT-1A) was reoptimized. The results are listed in table 12 which shows that the increase in gross weight of approximately 3 percent is mostly due to the increase in propulsion weight with the decrease in fuel specific impulse being largely offset by the increased ramjet thrust available in the Mach 3.5 to 4 region. In summation, it appears that should a diverter be required for the turbojet-ramjet system that the penalty in terms of aircraft growth would not be excessive.

6. STUDY CONCLUSIONS

In an aircraft that is operated in a conventional manner, i.e., takeoff to cruise to descent and landing, the off-design characteristics are of equal importance to the cruise performance. This is particularly true in the hypersonic transport due to its high growth sensitivity to weight and fuel consumption. This is emphasized in this study when one compares the propulsion characteristics that contributed to the final difference in the gross weights of the fixed and variable geometry systems. The fundamental reasons for the difference are due primarily to the following:

6.1 Installation Drag

Figure 20 shows a comparison of the individual drag items that make up the total installed propulsion drag. It is obvious that the major item is the spillage drag of the fixed geometry engine. The reason for the difference is that the variable geometry system with a common inlet can supply the airflow demands of both the turbojet and ramjet and in so doing reduces the spillage airflow to about 35 percent of the total as shown in Figure 21. In contrast, the fixed geometry system with separate inlets for both the turbojet and scramjet must spill about 65% of the total forebody streamtube which results in a much larger drag penalty which, in turn, requires a combination of more turbojets, or more capture area and/or higher fuel consumption during acceleration. A further penalty is incurred during subsonic cruise (reserve requirement) due to the high cold flow drag of the scramjet.

TABLE 12a. - AIRCRAFT WEIGHT COMPARISON OF TURBOJET - RAMJET SYSTEM WITH
RETRACTABLE AND FIXED DIVERTER (S.I. UNITS)

Range = 9260 km

		Retractable Diverter	Fixed Diverter
<u>Weights</u>	kg		
Gross wt.		278 136	286 448
Fuel		97 014	100 211
Payload		19 051	19 051
Oper. and Std. Items		6 328	6 410
Empty Weight		155 743	160 776
Structure		84 682	86 911
Propulsion:		(54 478)	(57 185)
Engine (Turbojets)		17 564	18 451
Air Inlet		7 339	8 110
Fuel & Oil System		2 831	2 906
LH ₂ Tanks, Insul. & Supports		24 254	25 053
Eng. Controls & Starter		402	422
Ramjets		2 096	2 242
Fur., Equip. and Subsystems		16 585	16 680
<u>Characteristics</u>			
W/S	ks/m ²	419.9	424.7
T/W	daN/kg	0.49	0.50
Ac/SREF	m ²	0.01225	0.0115
A _c	m ²	8.120	7 754
Fuel wt. fraction		0.3488	0.3498
Prop. wt. fraction		0.1959	0.1996
Total fuel & prop. fraction		0.5447	0.5494

TABLE 12b. - AIRCRAFT WEIGHT COMPARISON OF TURBOJET - RAMJET SYSTEM WITH
RETRACTABLE AND FIXED DIVERTER (CUSTOMARY UNITS)

Range = 5000 n.mi.

		Retractable Diverter	Fixed Diverter
<u>Weights</u>	(lb)		
Gross wt.		613 174	631 500
Fuel		213 175	220 924
Payload		42 000	42 000
Oper. and Std. Items		13 951	14 132
Empty Weight		343 349	354 444
Structure		186 688	199 603
Propulsion:		(120 098)	(126 069)
Engine (turbojets)		38 722	40 677
Air Inlet		16 179	17 880
Fuel & Oil System		6 242	6 407
LH ₂ Tanks, Insul & Supports		53 469	55 232
Eng. Controls & Starter		887	931
Ramjets		4 620	4 942
Fur., Equip. and Subsystems		36 563	36 773
<u>Characteristics</u>			
W/S	(lbs/ft ²)	86	87
T/W		0.50	0.51
A _c /S _{REF}		0.01225	0.0115
A _c	(ft ²)	87.4	83.47
Fuel wt. fraction		0.3488	0.3498
Prop. wt. fraction		0.1959	0.1996
Total fuel & prop. fraction		0.5447	0.5494

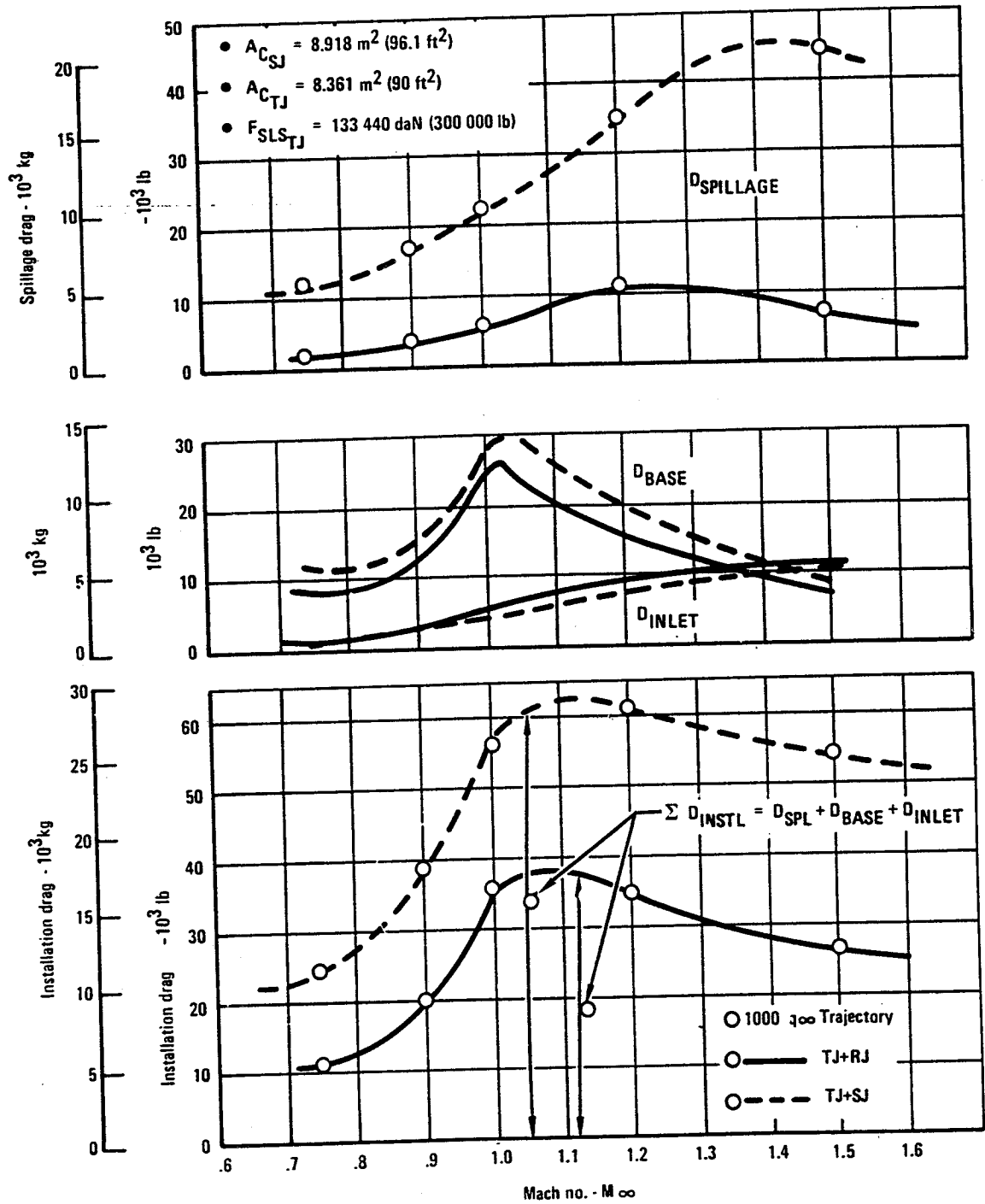

Figure 20. Installation drag comparison TJ-RJ and TJ-SJ systems.

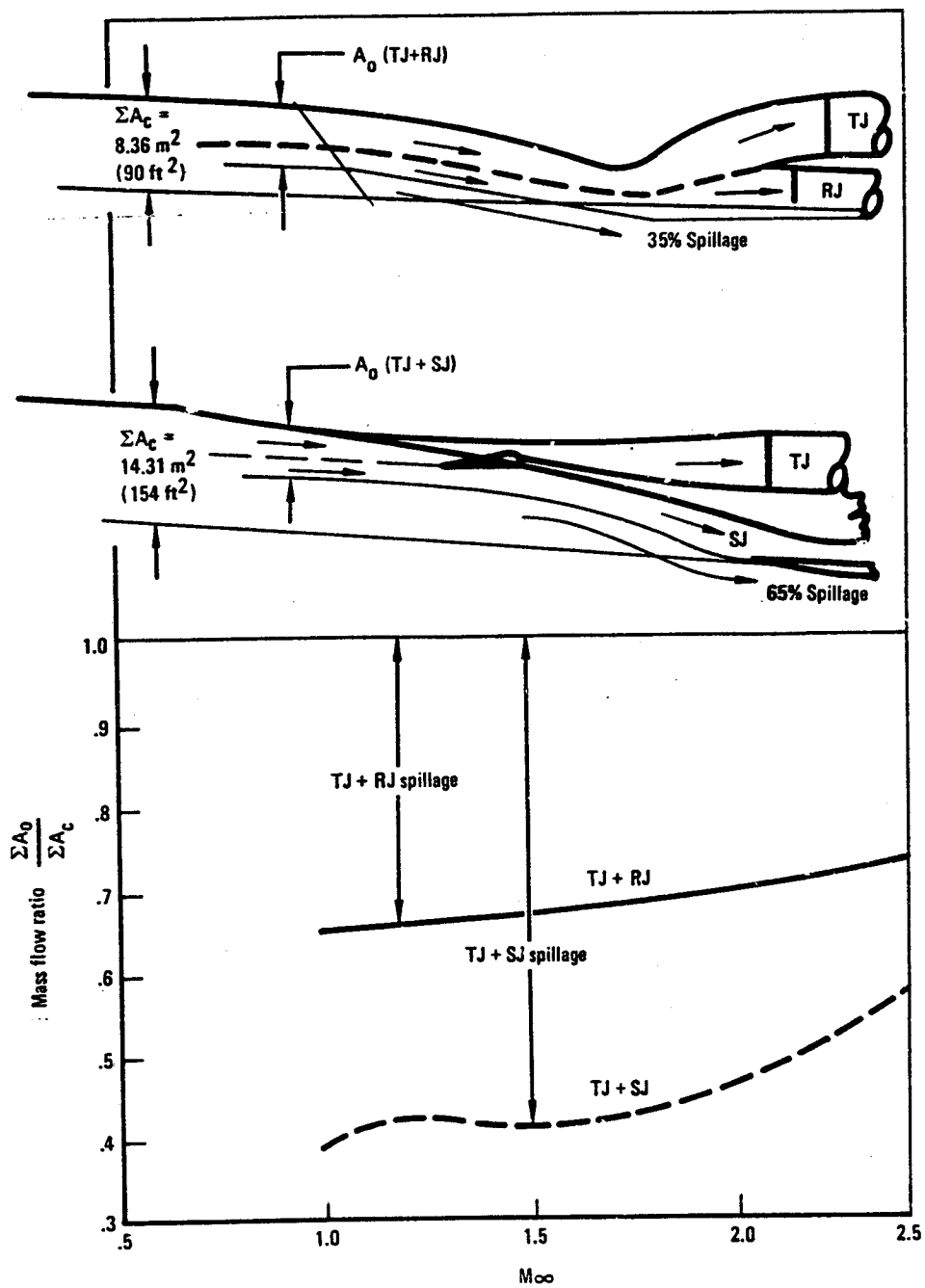

Figure 21. Inlet mass flow comparison, TJ-RJ and TJ-SJ systems.

6.2 Thrust Available, Mach 3.5 to 5

As described in section 5.3 a thrust deficiency in the scramjet system occurred at the end of turbojet shutdown. This required that the turbojet operation be extended to Mach 4. A further penalty in climb fuel consumption followed after turbojet shutdown in the Mach 4 to 5 region. This is shown in figure 22 which illustrates the lower thrust and Isp of the scramjet compared to the ramjet system. This is directly attributable to the fact that while the mass flow capacity of both systems is approximately equal, the total capture area of the turbojet plus the fixed geometry scramjet is 14.31 m^2 (154 ft^2) compared to 8.36 m^2 (90.6 ft^2) for the common inlet of the turbojet-ramjet systems as shown at the top of the figure. The lower mass flow ratio capability of the scramjet consequently causes an increase in spillage drag as indicated by the lower net Isp of the scramjet.

6.3 System Weight Comparison

A side-by-side comparison of the propulsion systems weights was prepared by holding a constant gross weight of 317 520 kg (700 000 lb) and using the optimum thrust to weight and A_c/b values determined for the final point design turbojet-scramjet and turbojet-ramjet (with fixed diverter) systems. Table 13 shows that while the sum of the common inlet plus the modules is only slightly more than the scramjets 11 475 kg (25 238 lb) compared to 10 839 kg (23 896 lb), the turbojet-scramjet requires a separate turbojet inlet with a total net penalty of 43 399 kg (9 566 lb) or 13.6 percent heavier than the ramjet system. Also shown in the table is the total fuel fraction plus tankage fraction for each system. The bottom line shows that the total weight penalty for the scramjet compared to the ramjet system is a gross weight fraction of .0257 or 8 160 kg (17 990 lb) at a constant gross weight of 31 7520 kg (700 000 lbs). This difference in weight then, considering the growth factor accounts for the final difference in gross weights of 350 953 kg (773 706 lbs) for the turbojet-scramjet and 286 448 kg (631 500 lbs) for the turbojet-ramjet systems with fixed diverter.

In summary, the essential difference of the systems is not in the combustion mode (subsonic vs supersonic) but is due to:

1. The reduction in both mission fuel consumption and installed propulsion weight made possible by the use of a common variable-geometry inlet for both the turbojet and ramjet engines. The reduction in spillage drag of the common inlet in the critical transonic region allows a smaller cowl size and reduced fuel consumption both in acceleration and subsonic cruise.

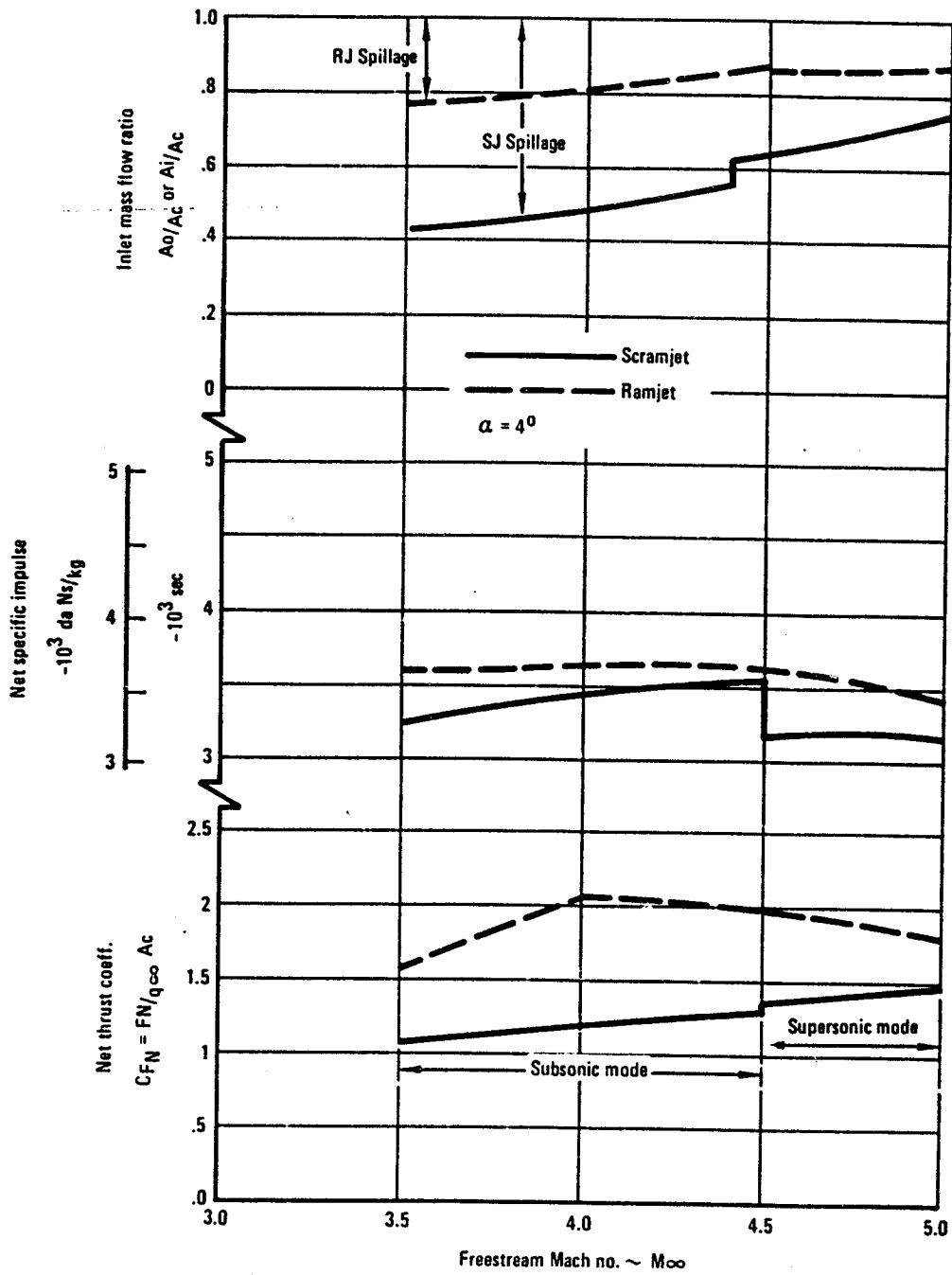

Figure 22. Performance comparison, Mach 3.5 to 5; TJ-RJ and TJ-SJ systems.

TABLE 13. - PROPULSION SYSTEMS WEIGHT COMPARISON

Gross weight = 317 520 kg (700 000 lb) $\frac{W}{S} = 424.7 \frac{\text{kg}}{\text{m}^2}$ (71 lb/ft²)

$S_{REF} = 747.5 \text{ m}^2$ (8046 ft²)

Characteristics:			TJ-SJ System		TJ-RJ System ^①	
	T/W (optimum)	$\frac{\text{daN}}{\text{kg}}$	(-)	0.49	(0.50)	0.50
A_c/S_{REF} (optimum)			0.0135	(0.0135)	0.0115	0.0115
A_c	m^2	(ft ²)	10.09	108.6	8.596	(92.5)
Weights:						
Turbojet F_{SLS}/W_{T_d}	$\frac{\text{daN}}{\text{kg}}$	(-)	7.433	(7.58)	7.767	(7.92)
Turbojet wt.	kg	(lb)	<u>20 945</u>	<u>(46 174)</u>	<u>20 447</u>	<u>(45 076)</u>
Scramjet system:						
TJ inlet specific wt.	$\frac{\text{kg}}{\text{m}^2}$	$(\frac{\text{lb}}{\text{ft}^2})$	595.6	(122)		
TJ capture area	m^2	(ft ²)	7.516	(80.9)		
TJ inlet wt	kg	(lb)	<u>4 477</u>	<u>(9 870)</u>		
SJ module specific wt.	$\frac{\text{kg}}{\text{m}^2}$	$(\frac{\text{lb}}{\text{ft}^2})$	1 074	(220)		
SJ internal area	m^2	(ft ²)	196.2	(2 112)		
SJ weight	kg	(lb)	<u>10 839</u>	<u>(23 896)</u>		
Ramjet system:						
Common inlet specific wt	$\frac{\text{kg}}{\text{m}^2}$	$(\frac{\text{lb}}{\text{ft}^2})$			1 045.7	(214.2)
Inlet wt.	kg	(lb)			<u>8 990</u>	<u>(19 820)</u>
RJ module specific wt. ^②	$\frac{\text{kg}}{\text{m}^2}$	$(\frac{\text{lb}}{\text{ft}^2})$			650.3	(133.2)
RJ internal area	m^2	(ft ²)			38.09	(410)
RJ wt	kg	(lb)			<u>2 485</u>	<u>(5 478)</u>
Total propulsion wt	kg	(lb)	36 261	(79 940)	31 922	(70 374)
Total propulsion wt fraction	-	-	0.1142	(0.1142)	0.1005	(-1 005)
Total fuel + tankage wt. fraction	-	-	0.4493	(0.4493)	0.4373	(0.4373)
Sum of propulsion + fuel and tankage fractions	-	-	<u>0.5635</u>	<u>(0.5635)</u>	<u>0.5378</u>	<u>(0.5378)</u>

^① With fixed diverter

^② $\frac{A_2}{A_c} = .444$ or $A_3 = (41.1 \text{ ft}^2)$

2. The use of this variable-geometry inlet increases the inlet air flow (and thrust) in the critical Mach 3.5 to 5 region after turbojet shutdown.

The net result is that the turbojet-scrumjet system is penalized in both fuel consumption and installed weight caused by high subsonic/transonic spillage drag and by low thrust in the Mach 3.5 to 5 region due to a lower mass flow resulting from the fixed geometry scrumjet engine.

Other conclusions reached in the configuration study phase are as follows:

- The gross weight of aircraft to perform the design mission are in the 272 160 to 362 880 kg (600 000 to 806 000 lb) class.
- The lift provided by a flattened fuselage forebody is important in improving hypersonic L/D and in providing the flow field and geometric width necessary for the propulsion installation. This is of particular importance in hydrogen-fueled aircraft with a large potential fuselage to wing planforms area ratio.
- The use of a horizontal tail in the selected configuration was required for trim purposes and "paid its way" by allowing the use of drooped ailerons to obtain more low speed lift with the final payoff being the reduction of wing size and weight. A further benefit is the reduction of the neutral point variation with Mach number.
- The most critical design criterion is to meet the landing field length constraint without increasing the wing aspect ratio or reducing the wing loading, both of which options result in increased gross weights.
- The propulsion system should be integrated with the fuselage to avoid excessive wave and friction drag. It should also be located far enough forward for balance purposes and to allow for takeoff rotation without requiring a long main gear for clearance. Further benefit is of the reduction of propulsion moments when the system is located near the center of gravity, and a reduction in the boundary layer displacement thickness. Adverse effects of the fuselage boundary layer could dictate the use of wing-mounted propulsion nacelles.
- The location and optimum inclination of the gross thrust vector can make a significant reduction in cruise fuel flow by reducing the aerodynamic lift required and subsequently the drag.
- Based on supersonic transport design experience and the high growth sensitivity of the hypersonic transport, the imposition of airport noise constraints would have a very adverse impact on vehicle size although it is possible that this could be mitigated to some extent by a variable cycle accelerator engine in which, as secondary benefit, the subsonic SFC could be improved thereby reducing the reserve fuel consumption.

7. STUDY RECOMMENDATIONS

The primary recommendation, considering the propulsion application to a transport mission, is to pursue the use of a common inlet for the acceleration and cruise engines and to provide a higher thrust level in the Mach 3 to 5 region by variable geometry or other means.

The majority of the remaining recommendations stem from uncertainties in the prediction methods used in the study. Testing and analytical correlation is required in the following areas:

- Demonstrate that either the variable or fixed geometry engines (inlet + combustor + nozzle) could operate efficiently while ingesting the boundary layer from the long fuselage forebody.
- If a diverter is required for either system what is the low speed drag and what lift contribution is caused by the shock field impingement on the fuselage or wing underside?
- Determine by test the spillage lift and drag forces in the transonic region.
- Simulate propulsion flows to determine base drags and moments.
- Further analytical work is required to define the comparative weights and cooling requirements of both propulsion systems.

REFERENCES

1. G.D. Brewer, R.E. Morris, G.W. Davis, E.F. Versaw, G.R. Cunnington, Jr., J.C. Riple, C.F. Baerst, G. Garmon, "Final Report - Study of Fuel Systems for LH₂ - Fueled Subsonic Transport Aircraft," NASA CR-145369, Lockheed-California Company for NASA-Langley Research Center, July 1978.