

N O T I C E

THIS DOCUMENT HAS BEEN REPRODUCED FROM
MICROFICHE. ALTHOUGH IT IS RECOGNIZED THAT
CERTAIN PORTIONS ARE ILLEGIBLE, IT IS BEING RELEASED
IN THE INTEREST OF MAKING AVAILABLE AS MUCH
INFORMATION AS POSSIBLE

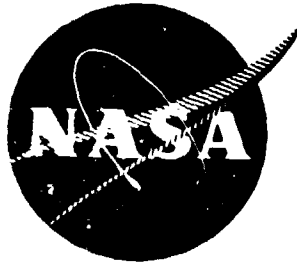

NASA CR-134872

CW-WR-77-024

**QUIET CLEAN SHORT-HAUL EXPERIMENTAL ENGINE
(QCSEE)**

**MAIN REDUCTION GEARS
DETAILED DESIGN FINAL REPORT
March 1975**

**by
Curtiss-Wright Corporation
Under Subcontract to General Electric Co.**

(NASA-CR-134872) QUIET CLEAN SHORT-HAUL
EXPERIMENTAL ENGINE (QCSEE) MAIN REDUCTION
GEARS DETAILED DESIGN REPORT Final Report
(Curtiss-Wright Corp.) 221 p HC A10/MF A01

N80-15106

Unclas
33488

CSCL 21F G3/07

Prepared For

National Aeronautics and Space Administration

NASA Lewis Research Center

Contract NAS 3-18021

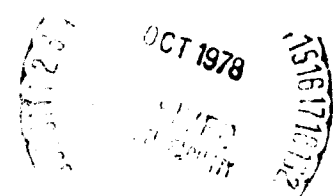

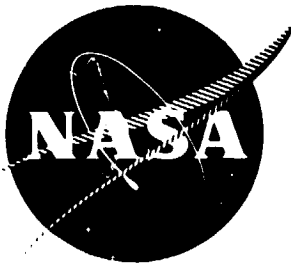

NASA CR-134872

QUIET CLEAN SHORT-HAUL EXPERIMENTAL ENGINE

(QCSEE)

MAIN REDUCTION GEARS

DETAILED DESIGN FINAL REPORT

March 1975

by

Curtiss-Wright Corporation

Under Subcontract to General Electric Co.

Prepared For

National Aeronautics and Space Administration

NASA Lewis Research Center

Contract NAS 3-18021

PRECEDING PAGE BLANK NOT FILMED

1. Report No. NASA CR-134872	2. Government Accession No.	3. Recipient's Catalog No.	
4. Title and Subtitle Quiet Clean Short-Haul Experimental Engine (QCSEE) Main Reduction Gears Detailed Design Final Report		5. Report Date July 1977	
		6. Performing Organization Code	
7. Author(s) A. DeFeo and M. Kulina, Power Systems Design and Analysis		8. Performing Organization Report No. CW-WR-77-024	
9. Performing Organization Name and Address Curtiss-Wright Corporation One Passaic Street Wood-Ridge, N. J. 07075 Under Contract to General Electric Company		10. Work Unit No.	
		11. Contract or Grant No. NAS3-18021	
12. Sponsoring Agency Name and Address National Aeronautics and Space Administration Washington, D.C. 20546		13. Type of Report and Period Covered	
		14. Sponsoring Agency Code	
15. Supplementary Notes Design Report: Project Mgr., C.C. Ciepluch, QCSEE Project Office, Technical Adviser, D. Reemsnyder, NASA Lewis Research Center, Cleveland, Ohio 44135 General Electric Co., Technical Adviser, W. Widlansky, 1 Jimson Rd. Cincinnati, Ohio 45215			
16. Abstract The General Electric Quiet Clean Short-Haul Experimental Engines use lightweight turbine engines with geared slower speed fans. This report covers the design of two similar but different gear ratio, minimum weight, epicyclic star configuration main reduction gears for the Under-The-Wing (UTW) and Over-The-Wing (OTW) engines. The UTW engine reduction gear has a ratio of 2.465:1 and a 100% power design rating of 9885 kW (13,256 hp) at 3143 RPM fan speed. The OTW engine reduction gear has a ratio of 2.062:1 and a 100% power design rating of 12813 kW (17183 hp) at 3861 RPM fan speed. Details of configuration, stresses, deflections and lubrication are presented.			
17. Key Words (Suggested by Author(s)) Aircraft Propulsion and Power Reduction Gear			
19. Security Classif. (of this report) Unclassified	20. Security Classif. (of this page) Unclassified	21. No. of Pages	22. Price*

891-0

TABLE OF CONTENTS

SUMMARY

- 1.0 INTRODUCTION
- 2.0 PRELIMINARY DESIGN
 - 2.1 Design Requirements
 - 2.2 Design Approach
- 3.0 DETAILED DESIGN - CLASS B (UTW) REDUCTION GEAR
 - 3.1 Mechanical Design
 - 3.2 Stress Analysis
 - 3.3 Deflection Analysis
 - 3.4 Natural Frequencies
- 4.0 DETAILED DESIGN - CLASS A (OTW) REDUCTION GEAR
 - 4.1 Mechanical Design
 - 4.2 Stress Analysis
 - 4.3 Deflection Analysis
 - 4.4 Natural Frequencies
- 5.0 CONCLUSIONS OR SUMMARY OF RESULTS

APPENDIX

- A - (UTW) Reduction Gear Bill of Material No. 210
- B - (UTW) Reduction Gear Weight Analysis
- C - (OTW) Reduction Gear Bill of Material No. 211
- D - (OTW) Reduction Gear Weight Analysis
- E - Mises Criterion

LIST OF TABLES

Table No.

2-1	Specification Preliminary Operating Parameters
2-2	Preliminary Design Ratios Analyzed
2-3	Preliminary Design Parameters
2-4	Experimental Engine Operating Requirements
2-5	Preliminary Design Parameters
2-6	Preliminary Design Gear Data - Class A Unit (OTW)
2-7	Preliminary Design Gear Data - Class B Unit (UTW)
2-8	Gear Materials Stress Allowables - AGMA
2-9	Gear Stresses - Experimental Engine Test Cycle
2-10	Total Oil Flows - Preliminary Design
2-11	Heat Rejection - Class A (OTW) Preliminary Design
2-12	Heat Rejection - Class B (UTW) Preliminary Design
2-13	Overall Reduction Gear Efficiency - Class A, 358°K (185°F) Oil
2-14	Overall Reduction Gear Efficiency - Class A, 361°K (190°F) Oil
2-15	Overall Reduction Gear Efficiency - Class A, 364°K (195°F) Oil
2-16	Overall Reduction Gear Efficiency - Class B, 358°K (185°F) Oil
2-17	Overall Reduction Gear Efficiency - Class B, 366°K (200°F) Oil
2-18	Overall Reduction Gear Efficiency - Class B, 372°K (210°F) Oil
2-19	Bearing Data - Preliminary Design
2-20	Scoring Index - AGMA
2-21	Preliminary Design Weight Analysis
3-1	Detail Design Objectives - UTW Reduction Gear
3-2	Detail Design Objectives - Experimental Engine Cycle
3-3	UTW Reduction Gear Data

LIST OF TABLES (Cont'd)

Table No.

3-4	Gear Data - UTW Reduction Gear
3-5	Gear Stress Data - UTW Reduction Gear
3-6	Bearing Data
3-7	Bearing Life Data
3-8	Total Oil Flows
3-9	Oil Supply Data
3-10	Overall Reduction Gear Efficiency
3-11	Heat Rejection
3-12	Scoring Index - Flight Cycle, AGMA
3-13	Scoring Index - Flight Cycle, C-W
3-14	Weight Summary - UTW Reduction Gear
3-15	Flight Unit Weight Reduction
3-16	Sun Gear Backing Stresses - 100% Speed, 100% Torque
3-17	Sun Gear Backing Stresses - 100% Speed, 140% Torque
3-18	Ring Gear Backing Stresses - 100% Speed, 100% Torque
3-19	Ring Gear Backing Stresses - 100% Speed, 140% Torque
3-20	Star Gear Backing Stress
3-21	Sun Gear "Combined" Stress
3-22	Ring Gear "Combined" Stress
3-23	Star Gear "Combined" Stress
3-24	Differential Deflections - Maneuver Loads
3-25	Maneuver Loads
3-26	Gear Backing Stresses - Maneuver Loads
3-27	"Combined" Stress - Flight Maneuvers

LIST OF TABLES (Cont'd)

Table No.

3-28	Star Gear Support Stress - Flight and Maneuver Loads
3-29	Flexible Coupling Stress - UTW Reduction Gear
3-30	Flexible Coupling Stress - Maneuver and Blade Out Loads
3-31	Gear Tooth Deflections
4-1	Detail Design Objectives - OTW Reduction Gear
4-2	Detail Design Objectives - Experimental Engine Cycle
4-3	OTW Reduction Gear Data
4-4	Gear Data - OTW Reduction Gear
4-5	Gear Stress Data - OTW Reduction Gear
4-6	Bearing Data
4-7	Bearing Life Data
4-8	Total Oil Flows
4-9	Oil Supply Data
4-10	Overall Reduction Gear Efficiency
4-11	Heat Rejection
4-12	Scoring Index - Flight Cycle, AGMA
4-13	Scoring Index - Flight Cycle, C-W
4-14	Weight Summary - Class A Reduction Gear
4-15	Flight Unit Weight Reduction
4-16	Sun Gear Backing Stresses - 100% Speed, 100% Torque
4-17	Sun Gear Backing Stresses - 100% Speed, 140% Torque
4-18	Ring Gear Backing Stresses
4-19	Star Gear Backing Stresses
4-20	Gear "Combined" Stresses

LIST OF TABLES (Cont'd)

Table No.

4-21	Differential Deflections - Maneuver Loads
4-22	Maneuver Loads
4-23	Gear Backing Stresses - Maneuver Loads
4-24	Gear "Combined" Stresses - Maneuver Loads
4-25	Star Gear Support Stress
4-26	Flexible Coupling Stress - Maneuver and Blade Out Loads
4-27	Gear Tooth Deflections

LIST OF FIGURES

Figure No.

- 2-1 Class A (OTW) Reduction Gear - Preliminary Design
- 2-2 Class B (UTW) Reduction Gear - Preliminary Design
- 2-3 Gear Tooth Lubrication
- 2-4 Gear Mesh Deflections
- 3-1 Class B (UTW) Reduction Gear - Detailed Design
- 3-2 Class B (UTW) Reduction Gear - Gear Layout
- 3-3 Class B (UTW) Reduction Gear - Spline Layout
- 3-4 Sun Gear Tooth Involute Profile Modification
- 3-5 Star Gear Tooth Involute Profile Modification
- 3-6 Ring Gear Tooth Involute Profile Modification
- 3-7 Star Gear Mesh Deflection
- 3-8 Star Gear Bearing Deflection
- 3-9 Goodman Diagram - Sun and Star Gears, Tooth Bending Stress
- 3-10 Goodman Diagram - Ring Gear, Tooth Bending Stress
- 3-11 Sun Gear High Stress Areas
- 3-12 Gear Load Diagram for "Combined" Stress
- 3-13 Goodman Diagram - Sun Gear Backing Stress
- 3-14 Ring Gear High Stress Areas
- 3-15 Goodman Diagram - Ring Gear Backing Stress
- 3-16 Star Gear High Stress Areas
- 3-17 Goodman Diagram - Star Gear Backing Stress
- 3-18 Goodman Diagram - Sun and Star Gear "Combined" Stress
- 3-19 Goodman Diagram - Ring Gear "Combined" Stress
- 3-20 Goodman Diagram - Sun and Star Gear "Combined" Stress for
Maneuvers
- 3-21 Goodman Diagram - Ring Gear "Combined" Stress for Maneuvers
- 3-22 Star Gear Support Stress Locations
- 3-23 Coupling Model - Stress Locations

LIST OF FIGURES (Cont'd)

Figure No.

3-24	Natural Frequencies Interference Diagrams - Sun and Ring Gears
4-1	Class A (OTW) Reduction Gear - Detailed Design
4-2	Class A (OTW) Reduction Gear - Gear Layout
4-3	Sun Gear Tooth Involute Profile Modification
4-4	Star Gear Tooth Involute Profile Modification
4-5	Ring Gear Tooth Involute Profile Modification
4-6	Star Gear Mesh Deflection
4-7	Star Gear Bearing Deflection
4-8	Goodman Diagram - Sun and Star Gears, Tooth Bending Stress
4-9	Goodman Diagram - Ring Gear, Tooth Bending Stress
4-10	Sun Gear Stress Locations
4-11	Goodman Diagram - Sun Gear Backing Stress
4-12	Ring Gear Stress Locations
4-13	Goodman Diagram - Ring Gear Backing Stress
4-14	Star Gear Stress Locations
4-15	Goodman Diagram - Star Gear Backing Stress
4-16	Goodman Diagram - Sun and Star Gears "Combined" Stress
4-17	Goodman Diagram - Ring Gear "Combined" Stress
4-18	Goodman Diagram - Sun and Star Gears "Combined" Stress for Maneuvers
4-19	Goodman Diagram - Ring Gear "Combined" Stress for Maneuvers
4-20	Natural Frequencies Interference Diagrams - Sun and Ring Gears

SUMMARY

The General Electric Quiet Clean Shorthaul Experimental Engine (QCSEE) being developed for NASA under Prime Contract NAS3-18021 utilizes a lightweight turbine engine with a geared slower-speed fan. Two engine-to-fan speed reducer gears with different ratios are being designed, fabricated and tested by the Power Systems Group, Curtiss-Wright Corporation under a sub-contract to General Electric Company.

This report covers the Analysis and Design Task, WBS Item 2.4, consisting of three major design sub-tasks: Preliminary Design, Detailed Design of two Reduction Gears, plus preparation of detailed drawings. One reduction gear is for an over-the-wing (OTW) engine application and the other is for an under-the-wing (UTW) engine application. General requirements were defined by General Electric Company Specification M 50TF1611-S1 dated January 25, 1974, Gear Assembly, Speed Decreaser.

Reduction gear configuration, engine interface definitions and reduction gear ratios were established and coordinated with General Electric during the preliminary design. Special features incorporated in the reduction gear design include the following.

1. Modular concept to permit installation and removal of the reduction gear and fan output shaft assembly as a unit.
2. Epicyclic gear with star arrangement; power input to sun gear, output from ring gear and stationary star gear support.
3. Interface points between the reduction gear and engine identical for the two different ratio units.
 - a. Input coupling attached to General Electric LP turbine shaft
 - b. Star gear support interface flange
 - c. Ring gear output spline
 - d. Oil supply tube

4. Flexibility in the sun gear and ring gear mountings with controlled gear deflections between the sun gear to star gear mesh and star gear to ring gear mesh.
5. Star gears supported by spherical roller bearings to allow self-alignment with the mating gears.
6. Gear tooth contact ratio of 2.0, hunting and non-factorizing tooth numbers for quiet operation.

An epicyclic star arrangement uses concentric internal and external gears (ring and sun) with a series of idlers (star gears) between them. The power turbine drives the sun gear which drives the ring gear through the set of star gears mounted on spherical roller bearings which in turn are mounted on a fixed carrier or support. The idlers or star gears provide multiple power paths between the input sun and output ring gears which permits both members to utilize many teeth to simultaneously carry the load. This gear arrangement results in a compact, minimum weight gear set.

Gear reduction ratios and input 100% power and speed conditions established by General Electric during the preliminary design and used for the detailed designs are:

Engine Application	UTW	OTW
Reduction Ratio	2.465	2.062
100% Power	9885 kW (13256 hp)	12813 kW (17183 hp)
100% Speed (Input)	811 rad/s (7747 rpm)	834 rad/s (7962 rpm)

The UTW engine reduction gear has six star gears and the OTW engine unit has eight star gears. Gear data are presented within the report.

Calculated oil flows and heat rejection data are the result of integrations with the engine overall heat balance studies conducted by General Electric. Calculated design objective gear efficiency of 99.2% minimum at the 100% speed and 100% power condition is exceeded by the 99.3% for the UTW engine reduction gear. Calculated efficiency for the OTW unit is 99.11%. Scoring index data for the gears were calculated and are acceptable.

Star gear spherical roller bearing tests, NASA CR-134890 report, confirmed the ability of the bearings to meet the operating loads and speeds. Calculated bearing B₁ life of 6110 hours exceeds the design objective of 6000 hours minimum at the flight spectrum operating conditions for the UTW engine star gear bearings. Calculated B₁ life for the OTW unit bearings is 5063 hours.

Calculated stresses in the reduction gear elements under several operational conditions, including the effects of maneuver load deflections, are all well within the current state-of-the-art limits.

Total weight of the reduction gear components included in the Curtiss-Wright design are 92.6 kg (204.2 pounds) and 89.9 kg (198.2 pounds) for the UTW and OTW engine applications, respectively. Weight reductions for a flight unit can be achieved by combining the Curtiss-Wright and General Electric support members, the use of titanium for the support and development effort to optimize the components for specific operational requirements.

1.0 INTRODUCTION

The General Electric Quiet Clean Shorthaul Experimental Engine (QCSEE) being developed for NASA under Prime Contract NAS3-18021 utilizes a lightweight turbine engine with a geared slower speed fan. Two engine-to-fan speed reducer gears with different ratios are being designed, fabricated and tested by the Power Systems Group, Curtiss-Wright Corporation under sub-contract to General Electric Company.

This report covers the Analysis and Design Task, WBS item 2.4, consisting of three major design sub-tasks: Preliminary Design, Detailed Design of two (2) reduction gears, plus preparation of detailed drawings. One reduction gear is for an over-the-wing (OTW) engine application and the other is for an under-the-wing (UTW) engine application. The General Electric/NASA experimental engine test schedule required that the UTW reduction gear detailed design be completed in advance of the OTW unit design.

QCSEE reduction gear design is based on the primary stage of a reduction gear developed by Curtiss-Wright for the Curtiss-Wright YT-49 and TP-51 turbo-prop engines. During the preliminary design phase specific interface concepts, conditions and requirements were coordinated between Curtiss-Wright and General Electric, and definitions for the detailed designs were established. Design concepts include a modular configuration to permit removal of the reduction gear from the engine as a unit and commonality of the reduction gear-to-engine interfaces for the OTW and UTW units.

The compact, light weight reduction gears enable development of quiet high performance turbofan engines utilizing advanced high speed gas turbines driving slower speed fans.

Data in this report are presented in both International System of Units (SI) units and English units. In the narrative the SI units are shown as the primary units and the English equivalents shown in parentheses; i.e., 1.0 kg (2.2 lbs). In tables where the number of items are small, both types of units are presented in adjacent columns. Table 2-1 is an example of this method. Where extensive data appears in a table, separate tables having the same basic

number but with a suffix "a" for the SI units and a suffix "b" for the English units are used. Tables 2-6a and 2-6b are an example of this procedure. Only the basic table number is used in the narrative for referring to the tables; i.e. Table 2-6. Dual scales for SI and English units are used on charts.

2.0 PRELIMINARY DESIGN

The QCSEE Main Reduction Gears design effort included two primary phases: Preliminary Design and Detailed Design and Analysis. The preliminary design phase covered approximately a four month period during which design approaches, General Electric Company engine requirements and design trade-offs were evaluated and coordinated between Curtiss-Wright and General Electric. A design review was conducted at the conclusion of the preliminary period and parameters defined for the detailed design.

2.1 Design Requirements

Basic design requirements for the QCSEE Main Reduction Gears were defined by General Electric Company Specification M50TF1611-S1 dated January 25, 1974, Gear Assembly, Speed Decreaser. This specification covers two classes of speed decelerators:

- a. Class A with a gear reduction ratio of approximately 2.1 for an over-the-wing (OTW) engine installation.
- b. Class B with a gear reduction ratio of approximately 2.5 for an under-the-wing (UTW) engine installation.

Preliminary operating parameters in the specification are shown in Table 2-1.

Operating life requirement with repair was 36,000 hours when operated in accordance with a Table 2-1 flight duty cycle. Specified time between overhauls was 6000 hours and the required B_1 life for the bearings was no less than 6000 hours based on the flight duty cycle. Other preliminary design objectives were light weight, minimum noise, operation with MIL-L-7808 or MIL-L-23699 oils at oil-in temperatures of 378°K (220°F) to 400°K (260°F), and a minimum overall efficiency of 99.2% at 100% speed and 100% power.

TABLE 2-1
 INITIAL SPECIFICATION OPERATING PARAMETERS
 (PRELIMINARY)

Design Data

Capability of 105% Speed Required

CLASS A (OTW)

100% Power	15130 HP	11282 kw
100% Output Speed	3783 rpm	396 rad/s
Gear Ratio	2.1 + 3% - 0%	

CLASS B (UTW)

100% Power	12500 HP	9321 kw
100% Output Speed	3197 rpm	335 rad/s
Gear Ratio	2.5 + 3% - 0%	

Condition	Oil In Temperature		Time %	Power %	Speed %
	°K	°F			
1 Start	-	-	1	-	0-30
2 Idle-Taxi	378	220	12	20	30
3 Take-Off	389	240	2	100	100
4 Climb	394	250	11	90	100
5 Cruise	394	250	28	70	90
6 Descent	400	260	25	30	75
7 Maneuver	400	260	5	60	70
8 Landing	400	260	4	55	95
9 Thrust Reverse	389	240	.3	70	100
10 Idle-Taxi	378	220	12	20	30

2.2 Design Approach

A fixed carrier epicyclic gear set with the power input to the sun gear and the output from the internal tooth ring gear has been selected to obtain the desired reduction ratios. A set of star gears are supported on the carrier through double row spherical roller bearings with the bearing outer race integral with the star gear to obtain maximum bearing capacity.

Gear ratios analyzed during the preliminary design phase together with the respective power turbine input speeds as specified by the GE engine analysis team are listed in Table 2-2. From the analyses, based on the gear pitch line velocity, the DN value for the star gear bearing and the capacity of the bearing limited by star gear size, the lowest ratio recommended for consideration for the Class A (OTW) gear assembly was 2.0617.

General Electric and Curtiss-Wright mutually agreed upon the design parameters shown in Table 2-3 for the continuing preliminary design studies. An additional requirement to be considered for the reduction gears was satisfactory operation in the Experimental Engines under the conditions shown in Table 2-4.

The design philosophy used in the gear assemblies is flexibility in the sun gear and ring gear mounting, controlled gear deflections between the sun gear to star gear mesh and star gear to ring gear mesh, and star gears having provision for self-alignment. This is discussed in greater detail later in this section. Gear tooth geometry selected provides a minimum contact ratio of 2.0 at each mesh point, a minimum of two teeth on each gear in contact at the mesh at all times. The number of teeth selected for each gear provides combinations which are hunting and non-factorizing. A non-factorizing epicyclic gear train is one in which the numbers of teeth on the sun, star and ring gears have no common factor and the number of teeth on neither the sun gear nor ring gear is evenly divisible by the number of star gears. A non-factorizing system is theoretically smoother and quieter than one that factorizes, since tooth actions overlap.

TABLE 2-2

PRELIMINARY DESIGN PHASE

GEAR RATIO INVESTIGATION

GEAR RATIO	INPUT SPEED RPM	NUMBER OF TEETH			NO. OF STARS	STAR RPM	BEARING BORE, MM	BEARING DxN/10 ⁶	PITCH LINE VEL.	
		SUN	STAR	RING GEAR					FT/MIN.	M/S
2.5409	8122	61	47	155	6	10542	70	.74	18882	95.92
2.4640	7878	71	52	175	6	10755	70	.75	19440	98.76
2.1733	8221	75	44	163	7	14014	65	.91	22489	114.24
2.1058	7966	85	47	179	8	14407	60	.86	22967	116.67
2.1010	7948	79	43	166	7	14602	65	.95	23431	119.03
2.0617	8228	81	43	167	8	15500	60	.93	24200	122.94
1.8915	8211	83	37	157	8	18420	55	.99	25680	131.37

TABLE 2-3
REDUCTION GEAR
DESIGN PARAMETERS

(PRELIMINARY DESIGN PHASE)

<u>CLASS A (OTW):</u>		
100% Power (Fan)	11111 kW	14900 hp
100% Output Speed	404 rad/s	3859 rpm
Gear Ratio		2.062
B ₁ Bearing Life (Flight Cycle)		6224 hrs
Bearing DN Value		.90 x 10 ⁶
<u>CLASS B (UTW):</u>		
100% Power (Fan)	9247 kW	12400 hp
100% Output Speed	329 rad/s	3143 rpm
Gear Ratio		2.465
B ₁ Bearing Life (Flight Cycle)		7271 hrs
Bearing DN Value		.74 x 10 ⁶
*B ₁ Life based on Catalog C Values		

TABLE 2-4
EXPERIMENTAL ENGINE OPERATION REQUIREMENT

% POWER	% SPEED	TIME - HRS.
100	105	1
140	100	1
130	100	15
110	100	15
100	100	150
80	90	500
50	75	1000
10	30	<u>1000</u>
TOTAL TIME		2682
100% Power same as shown in Table 2-3 100% Speed same as shown in Table 2-3		

Hunting is a distinct quality and tends to correct small imperfections by increasing the number of different teeth with which a given tooth makes contact. Complete hunting requires that the numbers of teeth of any two meshing gears have no common factors higher than one. Complete hunting was achieved in both gear assemblies.

The meshing requirement for the epicyclic gear train with equally-spaced stars is:

	$\frac{O+S}{n}$	= a whole number
where,	O	= Number of teeth in ring gear
	S	= Number of teeth in the sun gear
	n	= Number of stars

The following data and calculations show how the Class A (OTW) and Class B (UTW) gear sets meet the assembly, hunting and non-factorizing criteria.

		Class A (OTW)	Class B (UTW)
Sun Gear Teeth,	S	81	71
Star Gear Teeth		43	52
Ring Gear Teeth,	O	167	175
Number of Stars,	n	8	6
Assembly Requirements	$\frac{O+S}{n}$	$\frac{167 + 81}{8} = 31.0$	$\frac{175 + 71}{6} = 41.0$
Hunting Check	$\frac{\text{sun}}{\text{star}}$	$\frac{81}{43} = 1 + \frac{38}{43}$	$\frac{71}{52} = 1 + \frac{19}{52}$
	$\frac{\text{ring}}{\text{star}}$	$\frac{167}{43} = 3 + \frac{38}{43}$	$\frac{175}{52} = 3 + \frac{19}{52}$
Non-factorizing Check	$\frac{S}{n}$	$\frac{81}{8} = 10 + \frac{1}{8}$	$\frac{71}{6} = 11 + \frac{5}{6}$
	$\frac{O}{n}$	$\frac{167}{8} = 20 + \frac{7}{8}$	$\frac{175}{6} = 29 + \frac{1}{6}$

The design approach developed early in the preliminary design phase was a modular concept carrier support for installation and removal of the reduction gear as a unit with the output shaft. This arrangement shown in Figures 2-1 and 2-2 achieved commonality for Class A (OTW) and Class (UTW) units to the extent that both gear assemblies utilize a common core engine, fan turbine, sun gear coupling, output shaft assembly and oil supply.

The sun gear assembly consists of a sun gear, a double diaphragm coupling, and a lock ring. Aft end of the double diaphragm coupling is attached to the power turbine shaft. The double diaphragm coupling is identical for both Class A (OTW) and Class B (UTW) gear assemblies. Forward element of the double diaphragm coupling is attached to the aft element with a bolted joint capable of carrying the input torque in friction. The sun gear for Class A (OTW) or Class B (UTW) gear assembly is splined to the forward end of the double diaphragm coupling with a full depth 20° pressure angle involute spline, and is positioned fore and aft with lock ring which is common to both Class A (OTW) and Class B (UTW) gear assemblies. The retaining ring type lock ring shown in preliminary design Figures 2-1 and 2-2 was replaced by a flanged bayonet lock ring bolted to the sun gear for the detailed design.

Star gears are mounted on double row spherical roller bearings with the outer race of the bearing integral with the star gear. Star gear assemblies are self-aligning and permit angular displacements. Symmetrical rollers of large diameter with close conformity between rollers and raceway result in high load ratings, making this configuration especially suitable for heavy duty applications. Sections through the gears and bearings are shown in Figures 2-1 and 2-2.

Star gear assemblies are mounted on a fixed carrier support with an interference fit and clamped with a threaded nut. The fixed carrier is attached to an intermediate cone structure which in turn is attached to the composite structural frame of the engine. The fixed carrier is bolted at the I.D. of the intermediate cone structure and is positioned with an O.D. pilot diameter. The bolting flange and the interference fit pilot diameter are identical for both Class A (OTW) and Class B (UTW) gear assemblies. For production engines it is anticipated that the fixed carrier and intermediate cone structure can

ORIGINAL PAGE IS
OF POOR QUALITY

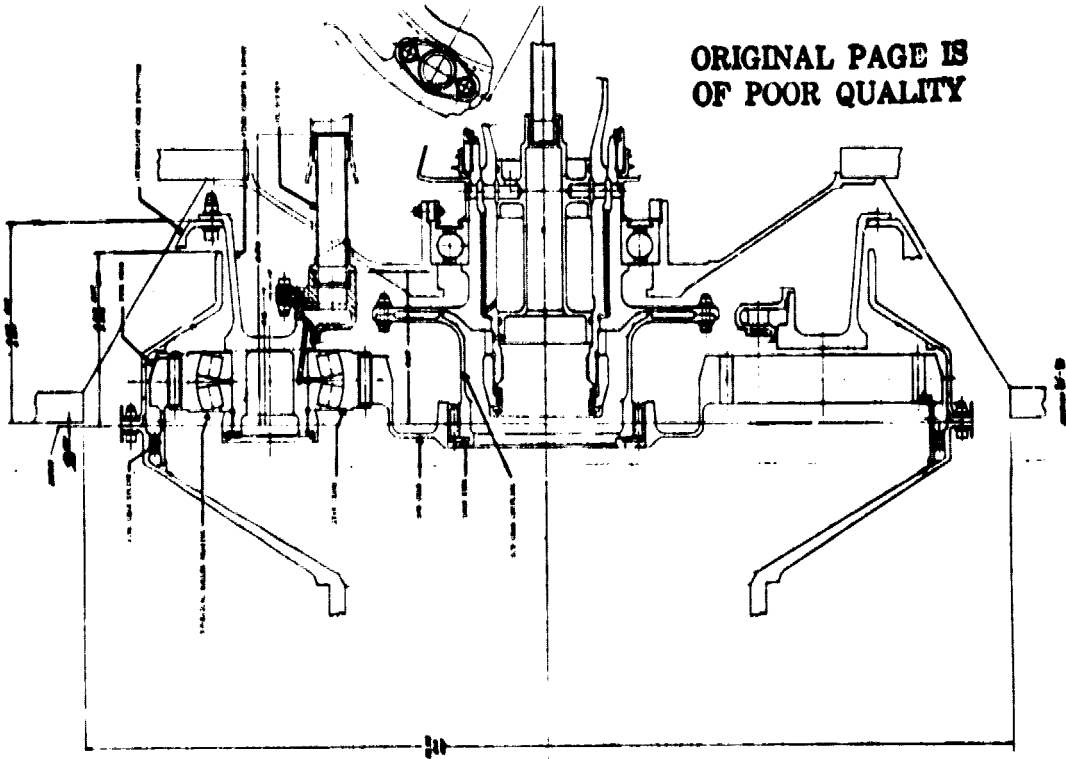

CLASS A (NAVY) REDUCTION GEAR - PRELIMINARY DESIGN

Figure 2-1

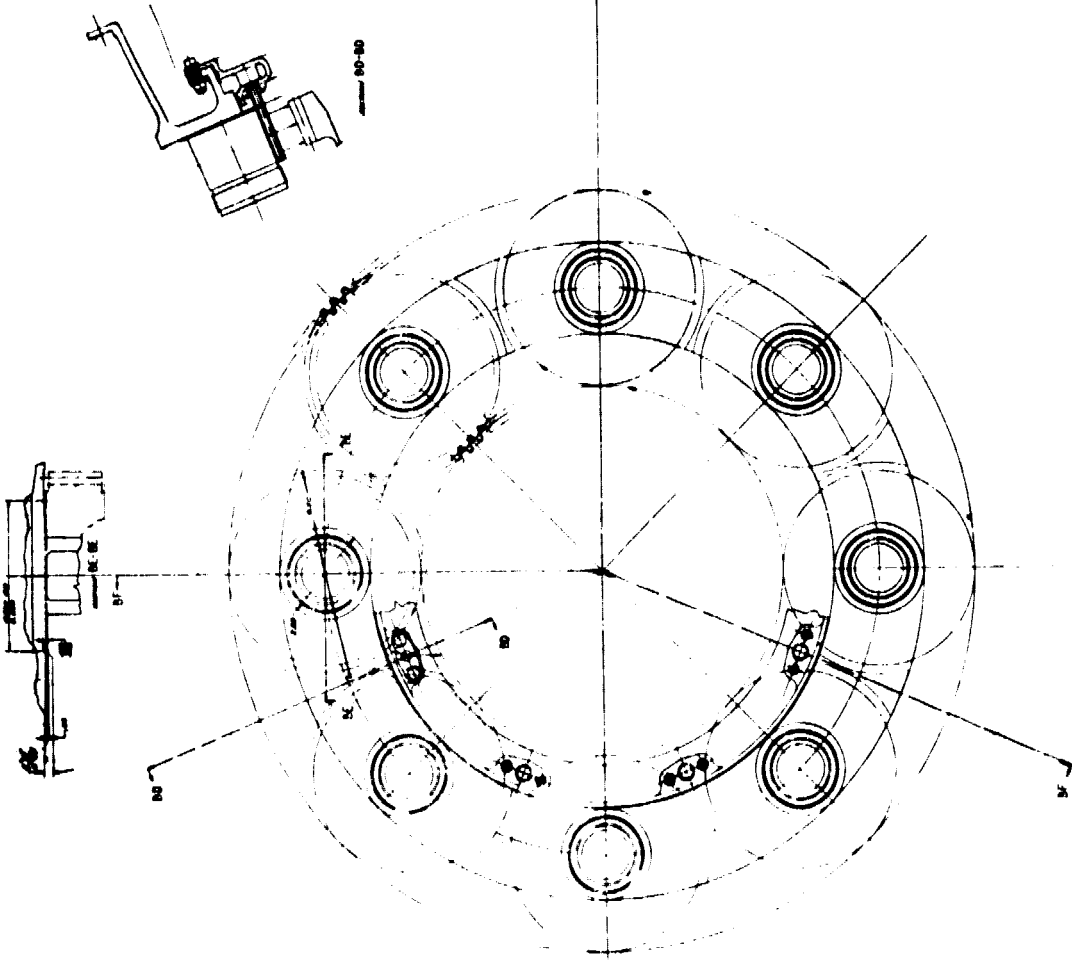

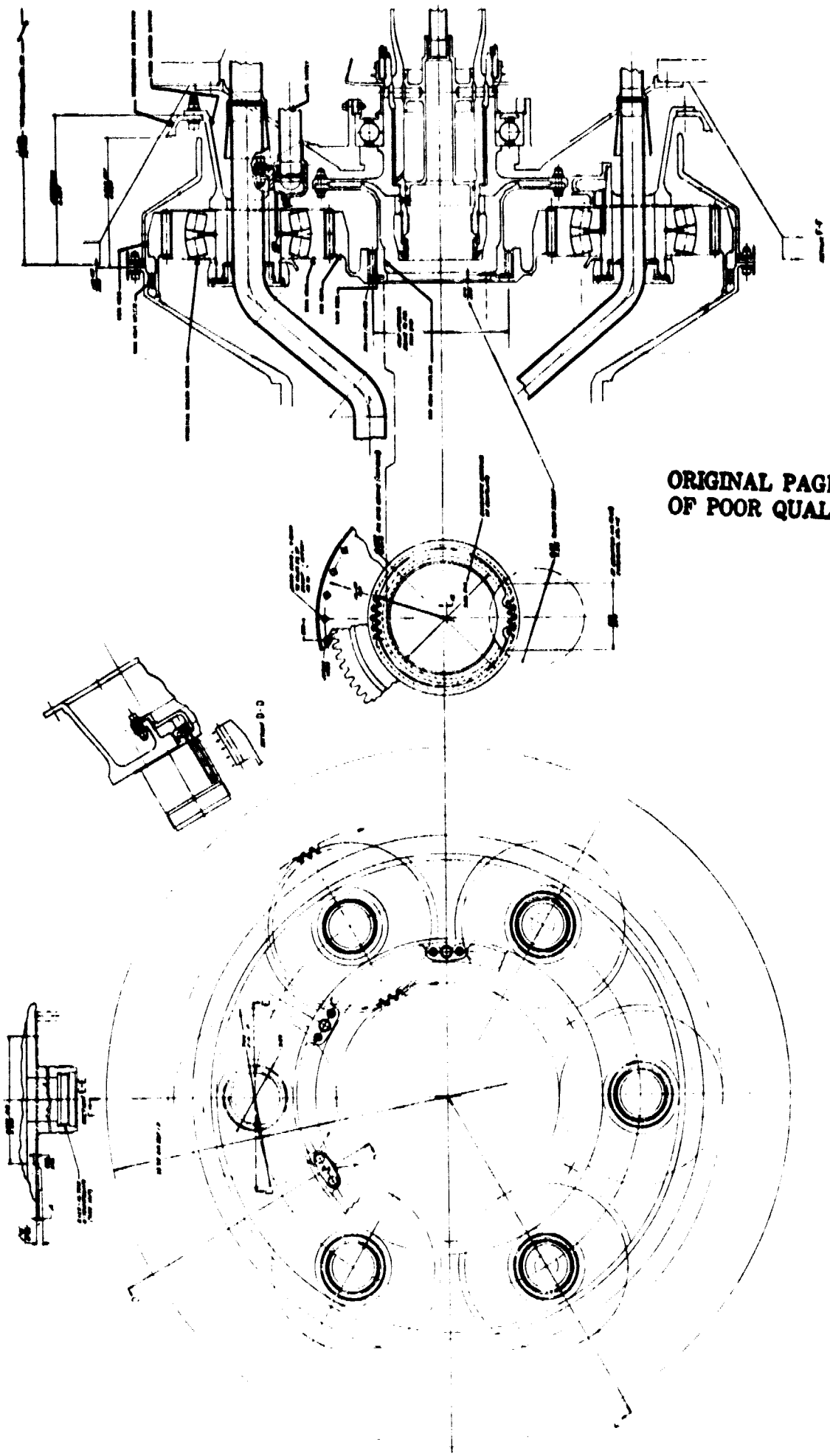

ORIGINAL PAGE IS
OF POOR QUALITY

CLASS 3 INJECTOR GUN ASSEMBLY - PRELIMINARY DESIGN

Figure 2-2

be one piece, thus eliminating the bolting flange and pilot diameter. This integral configuration would result in a weight saving. The output shaft aft roller bearing is mounted in the intermediate cone structure and is supplied oil from the fixed carrier. Oil feed to the output shaft roller bearing is common for both Class A (OTW) and Class B (UTW) gear assemblies. Details of the component arrangement are shown in preliminary design Figures 2-1 and 2-2 and in the detailed design section.

Basic cross-section of the fixed carrier support is a vertical base ring with an O.D. flanged conical section and an I.D. cylindrical section to provide the required section modulus for the trunnions which are cantilevered from the base ring.

Mounted to the I.D. of the fixed carrier is a U-shaped cross-section aluminum manifold which forms the oil supply annulus for the star gear bearings, gear mesh spray bars and the G.E. fan shaft thrust and roller bearings. The oil manifold is bolted to the aft inner flange of the fixed carrier and is sealed on two diameters with Viton 'A' "O" rings. Oil supply line is bolted to the aft face of the oil manifold with a two bolt flange and is sealed with a Viton A "O" ring. The oil supply line is common for both OTW and UTW gear assemblies. Gear mesh spray bars are mounted on the front face of the oil supply manifold with a two bolt flange and sealed with a Viton A "O" ring. Five axial positioned jets, located 21° from a radial line through the center of the sun gear assembly and the center of the gear mesh spray bar, direct oil to the sun gear teeth in the direction of sun gear rotation as shown in Figure 2-3. Five additional axial positioned jets are located 21° from a line through the center of the star gear assembly and the center of the gear mesh spray bar, spraying the star gear teeth in the direction of the star gear rotation.

Aluminum oil retaining sleeves inside the star gear carrier trunnions provide cavities fed from the oil manifold. These sleeves are sealed with two O.D. Viton A "O" rings and are retained axially with self locking Spirolox rings. Oil flow from the cavity to the bearing is metered by a radial hole in the trunnion. An annulus and radial passages in the center of the bearing inner race distributes oil to the bearing. Two of the oil retaining sleeves have

GEAR TOOTH LUBRICATION

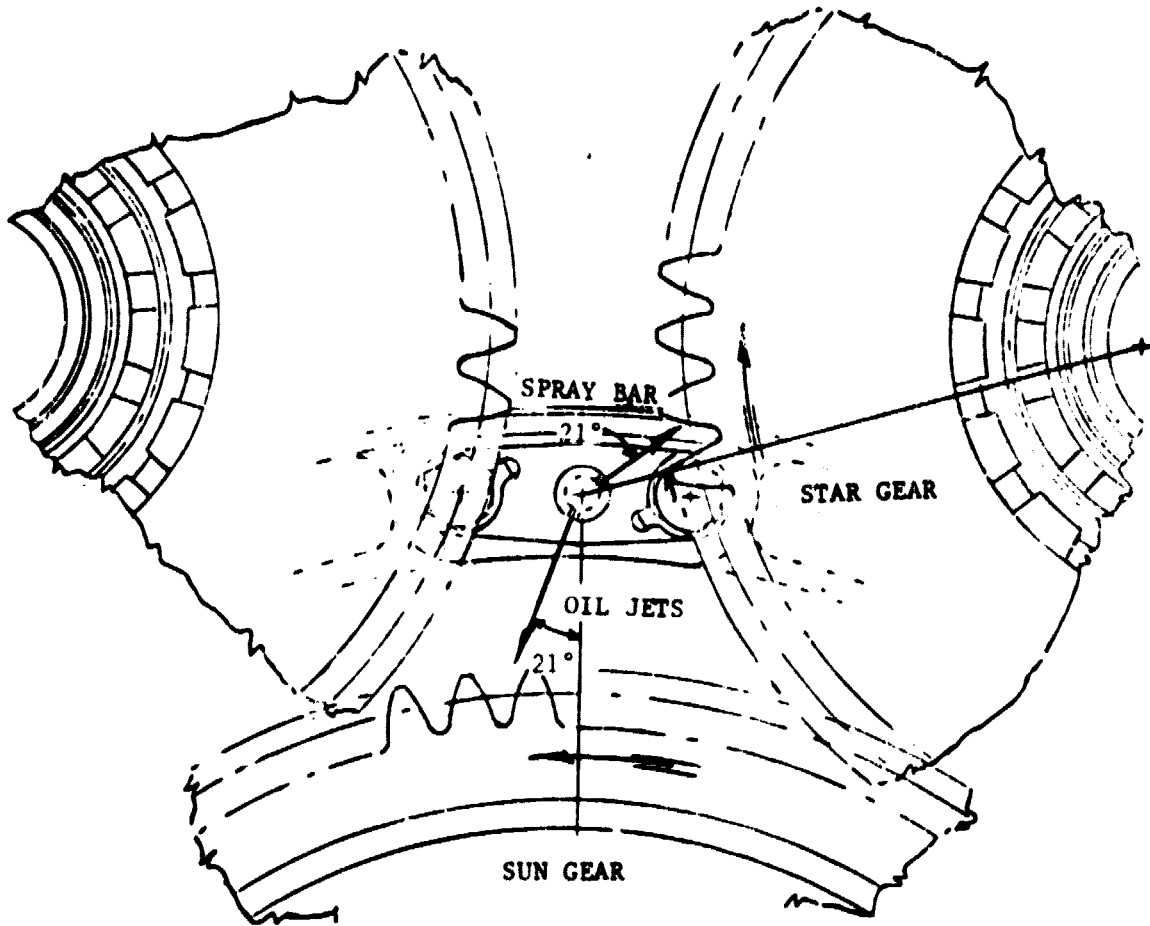

ORIGINAL PAGE IS
OF POOR QUALITY

Figure 2-3

six equally spaced holes and two close-stepped I.D.'s for accepting General Electric engine oil tubes that lubricate the fan thrust bearing, oil seal and sun gear spline. These are shown in Figures 3-1 and 4-1 in the subsequent detailed design sections.

Space is provided on the Class B (UTW) gear assembly trunnions for mounting the General Electric supplied fan variable pitch control mechanism support which interconnects all six trunnions. In the Class A (OTW) gear assembly, axial space and two rectangular grooves located 180° apart on the O.D. of the trunnion are provided for mounting individual supports for the General Electric thrust bearing lubrication tubes.

Output ring gear contains an internal gear and a full depth 20° pressure angle involute external spline connected by a thin cylindrical section. Twenty-four oil drain holes are provided in the thin section. The spline on the forward end of the ring gear mates with an internal spline in the fan shaft. The ring gear is positioned axially by eighteen protrusions inside the forward and aft fan shaft members. The spline and axial length of the ring gears are identical for the Class A (OTW) and Class B (UTW) reduction gear units to provide fan shaft commonality.

Preliminary design phase of the program included general design layouts of the Class A (OTW) gear assembly, Figure 2-1, and the Class B (UTW) gear assembly, Figure 2-2. These configurations satisfy the required commonality for the two units at each interface point between the reduction gear and the engine.

The gear design tooth geometry was optimized to achieve a balanced design between bending stress, Hertz stress and scoring index for the two meshes involved, i.e., sun gear to star gear and star gear to internal gear, for integral contact ratios of at least 2.0. Gear analyses were performed with a computer gear program which calculates AGMA Standard bending stress per AGMA Standard 225.01. Included in the input are the following factors for both meshing gears: numbers of teeth, diametral pitch, pressure angle, circular tooth thickness, operating center distance, maximum normal backlash, torque, face width, modulus of elasticity, reduction of addendum due to tolerance and break edges, addendums, dedendums and maximum normal protuberance of

cutter. The program accommodates both external meshing and internal meshing gears, and accounts for cutter protuberance reducing tooth thickness at the root for the calculation of the bending stress.

Gear layouts for Class A (OTW) and Class B (UTW) units were executed and continually updated as new General Electric inputs as to fan horsepower and fan speed were evaluated to verify the geometry specified by the output of the gear program.

The 100 percent power and 100 percent speed condition design parameters in effect at the presentation of the preliminary design review are shown by Table 2-5. Gear data as optimized during the preliminary design phase is summarized in Table 2-6 and Table 2-7 for the Class A (OTW) and Class B (UTW) reduction gears, respectively.

AGMA allowables for bending stress and contact stress for the two materials used in the gear assemblies are shown by Table 2-8. Also listed are the Curtiss-Wright recommended limits for minimum risk with a minimum development program, and the values of Curtiss-Wright operating experience on production gear sets that have extensive development background. Calculated bending and contact stresses for the Class A (OTW) and Class B (UTW) gear assemblies most severe experimental test engine cycle conditions as shown in Table 2-9 fall below Curtiss-Wright operating experience on gearing.

Scoring index analyses were made to determine the suitability of the gear geometry or the need for tooth geometry change if the values were found excessive.

Curtiss-Wright scoring evaluation is a procedure based on the works of Blok, Kelley, Lemanski, and Curtiss-Wright scoring test development programs. The active involute contact line is divided into one hundred equally spaced increments and the procedure determines all pertinent parameters, especially the coefficient of friction at all points. For these calculations, the gear tooth driving load is assumed to vary parabolically along the line of involute action from a maximum at the pitch point to one sixth of the average value at the first and last points of contact. Load level at these points is taken such that the area under the load curve is the same as the area under the

TABLE 2-5

PRELIMINARY DESIGN PHASE PARAMETERS		
(100% POWER, 100% SPEED)		
APPLICATION	UTW	OTW
Ratio	2.465	2.062
Turbine Power	9843 kW 13200 HP	12813 kW 17183 HP
Turbine Speed	811 rad/s 7747 rpm	834 rad/s 7962 rpm
No. of Stars	6	8
Pitch Line Vel	97.1 m/s 19118 ft/min.	119.3 m/s 23488 ft/min.
Star Speed	1108 rad/s 10577 rpm	1571 rad/s 14998 rpm
Bearing Load	33782 N 7595 lbs	26844 N 6035 lbs
Sun Gear Teeth	71	81
Star Gear Teeth	52	43
Ring Gear Teeth	175	167
Hunting	Yes	Yes
Non Factorizing	Yes	Yes

TABLE 2-6
 GEAR DATA
 CLASS A (OTW) UNIT
 (PRELIMINARY DESIGN PHASE)

SI UNITS

	SUN GEAR	STAR GEAR	RING GEAR
No. of Teeth	81	43	167
Module	3.5335	3.5335	3.5335
Pressure Angle, deg	21	21	21
Pitch Diameter, mm	286.2110	151.9392	590.0895
Center Distance, mm		219.1	219.1
Tooth Thick. (PD), mm	5.476	5.623	5.476
Backlash, mm	.102-.152	.102-.152	.127-.203
Root Rad., mm	1.17	1.50	.53
Contact Ratio (Min.) (Max. Break Edges)	2.111	-	2.114
Contact Ratio (Min.) (No Break Edges)	2.001	-	1.987
Bending Stress, N/cm ²	22,532	22,262	19,212
Contact Stress, N/cm ²	88,139	-	61,383
Material	AMS6265	AMS6265	AMS6470

ENGLISH UNITS

	SUN GEAR	STAR GEAR	RING GEAR
No. of Teeth	81	43	167
Diametral Pitch	7.1884	7.1884	7.1884
Press. Angle, Deg.	21	21	21
Pitch Dia., in.	11.26815	5.98186	23.23187
Center Distance, in.		8.625	8.625
Tooth Thick. (PD), in.	.2156	.2214	.2156
Backlash, in.	.004-.006	.004-.006	.005-.008
Root Rad., in.	.046	.059	.021
Contact Ratio (Min.) (No Break Edges)	2.111	-	2.114
Contact Ratio (Min.) (Max. Break Edges)	2.001	-	1.987
Bending Stress, psi	32,680	32,288	27,864
Contact Stress, psi	127,835	-	89,029
Material	AMS6265	AMS6265	AMS6470

TABLE 2-7

GEAR DATA

CLASS B (UTW) UNIT
(PRELIMINARY DESIGN PHASE)

SI UNITS

	SUN GEAR	STAR GEAR	RING GEAR
No. Teeth	71	52	175
Module	3.3722	3.3722	3.3722
Pressure Angle, deg.	21	21	21
Pitch Dia, mm	239.43	175.36	590.14
Center Distance, mm		207.39	207.39
Tooth Thick. (PD), mm	5.3404	5.2527	5.3424
Backlash, mm	.102-.152	.102-.152	.127-.203
Root Rad., mm	1.09	1.27	.500
Contact Ratio (min.) (No Break Edge)	2.123	-	2.121
Contact Ratio (min.) (Max. Break Edge)	2.006	-	1.986
Bending Stress, N/cm ²	24,636	24,467	20,479
Contact Stress, N/cm ²	88,637	-	56,458
Material	AMS6265	AMS6265	AMS6470

ENGLISH UNITS

	SUN GEAR	STAR GEAR	RING GEAR
No. of Teeth	71	52	175
Diametral Pitch	7.5321	7.5321	7.5321
Press Angle, deg.	21	21	21
Pitch Dia., in.	9.4263	6.9038	23.2339
Center Distance, in.		8.1650	8.1650
Tooth Thick (PD), in.	.21025	.2068	.21033
Backlash, in.	.004-.006	.004-.006	.005-.008
Root Radius, in.	.043	.050	.020
Contact Ratio (Min.) (No Break Edges)	2.123	-	2.121
Contact Ratio (Min.) (Max. Break Edges)	2.006	-	1.986
Bending Stress, psi	35,731	35,386	29,703
Contact Stress, psi	128,557	-	81,885
Material	AMS6265	AMS6265	AMS6470

TABLE 2-8
GEAR MATERIAL STRESSES

SI UNITS

	BENDING	CONTACT STRESS
AGMA ALLOWABLE		
AMS 6265 MATERIAL		
SINGLE TOOTH LOADING, N/cm^2	$S_b = 38,691$	$S_c = 102,566$
LOADING BOTH DIRECTIONS, N/cm^2 (70% OF SINGLE TOOTH LOADING)	$S_b = 26,958$	
AMS 6470 MATERIAL		
SINGLE TOOTH LOADING, N/cm^2	$S_b = 32,887$	
CURTISS-WRIGHT RECOMMENDATION		
MINIMUM RISK, N/cm^2	$S_b = 24,132$	$S_{ac} = 93,079$
CURTISS-WRIGHT OPERATING EXPERIENCE, N/cm^2	$S_b = 41,369$	$S_{ac} = 110,316$

ENGLISH UNITS

	BENDING	CONTACT STRESS
AGMA ALLOWABLE		
AMS 6265 MATERIAL		
SINGLE TOOTH LOADING	$S_b = 56,117 \text{ psi}$	$S_c = 148,760 \text{ psi}$
LOADING BOTH DIRECTIONS (70% OF SINGLE TOOTH LOADING)	$S_b = 39,100 \text{ psi}$	
AMS 6470 MATERIAL		
SINGLE TOOTH LOADING	$S_b = 47,699 \text{ psi}$	
CURTISS-WRIGHT RECOMMENDATION		
MINIMUM RISK	$S_b = 35,000 \text{ psi}$	$S_{ac} = 135,000 \text{ psi}$
CURTISS-WRIGHT OPERATING EXPERIENCE	$S_b = 60,000 \text{ psi}$	$S_{ac} = 160,000 \text{ psi}$

TABLE 2-9a

GEAR STRESSES (SI UNITS)

(EXPERIMENTAL TEST ENGINE CYCLE)

(EXTERNAL MESH)

(PRELIMINARY DESIGN PHASE)

TURBINE-rad/s CLASS A (OTW)	kW	BENDING STRESS N/cm ²		CONTACT STRESS N/cm ²	DURATION- HRS.
		SUN	STAR		
875.5	12,813				1
833.8	17,939	31,548	31,168	104,291	1
833.8	16,657	29,291	28,939	100,492	15
833.8	14,094	24,787	24,489	92,444	15
833.8*	12,813*	22,300	22,489	88,139	150
750.4	10,250				500
625.4	6,407				1000
250.2	1,281				1000
CLASS B (UTW)					
851.8	9,843				1
811.3	13,780	34,489	34,252	104,875	1
811.3	12,796	32,060	31,806	101,060	15
811.3	10,828	27,098	26,912	92,961	15
811.3*	9,843*	24,636	24,467	88,637	150
730.1	7,875				500
608.4	4,922				1000
243.4	984				1000

*100% Power, 100% Speed Condition

TABLE 2-9b

GEAR STRESSES (ENGLISH UNITS)

(EXPERIMENTAL TEST ENGINE CYCLE)

(EXTERNAL MESH)

(PRELIMINARY DESIGN PHASE)

TURBINE rpm	HP	BENDING STRESS psi		CONTACT STRESS psi	DURATION- HRS.
		SUN	STAR		
CLASS A (OTW)					
8360	17183				1
7962	24056	45756	45206	151,262	1
7962	22337	42483	41972	145,751	15
7962	18901	35950	35518	134,078	15
7962*	17183*	32343	32617	127,835	150
7166	13746				500
5972	8592				1000
2389	1718				1000
CLASS B (UTW)					
8134	13200				1
7747	18480	50022	49679	152,108	1
7747	17160	46449	46130	146,575	15
7747	14520	39302	39032	134,828	15
7747*	13200*	35731	35486	128,557	150
6972	10560				500
5810	6600				1000
2324	1320				1000

*100% Power, 100% Speed Condition

average load; thus, energies are equated. The program determines the maximum temperature within the area of contact between gear teeth; this calculated temperature is called the "scoring index". This calculated scoring index is then compared with an allowable "flash index temperature" for the gear material and lubricant. Program outputs are as follows: involute roll angles, pinion approach ratio, lubricant viscosity, mesh loss, scoring indices, and locations.

A scoring index was also calculated by the AGMA procedure to simplify comparison with published data. AGMA 217.01 lists a gear scoring design guide for aerospace spur gears which is divided into three bands: low scoring risk, medium scoring risk, and high scoring risk. Based on Curtiss-Wright experience and the Curtiss-Wright scoring program, a maximum permissible AGMA scoring index of 300°F was established.

To establish the required oil inlet temperatures during projected flight a parametric analysis of gear box total heat rejection at each flight condition was made for the following oil inlet temperatures using MIL-L-23699 oil:

Class A (OTW) 358°K (185°F), 361°K (190°F) and 364°K (195°F)

Class B (UTW) 358°K (185°F), 366°K (200°F) and 372°K (210°F)

The analysis was executed for the flight cycle using the agreed upon values of power and speed for the preliminary design phase (Table 2-3). Calculated oil flows for both Class A (OTW) and Class B (UTW) reduction gears are shown in Table 2-10.

Heat rejection and bulk oil outlet temperatures for the Class A (OTW) unit and the Class B (UTW) unit are shown in Table 2-11 and Table 2-12, respectively. Calculated power losses for bearings, gear mesh, churning and windage, and overall efficiency for the three oil inlet temperatures for the Class A (OTW) unit are shown in Tables 2-13, 2-14 and 2-15. Comparable data for the Class B (UTW) unit are shown in Tables 2-16, 2-17 and 2-18. Varying the oil temperature from 358°K (185°F) to 364°K (195°F) for the Class A (OTW) unit and from 358°F (185°F) to 372°K (210°F) for the Class B (UTW) unit had only minute effects on the overall efficiencies.

TABLE 2-10
TOTAL OIL FLOWS
(PRELIMINARY DESIGN, PHASE)
MIL-L-23699 OIL
SI UNITS

UTW			OIL IN TEMPERATURES	OTW		
cm ³ /s				cm ³ /s		
358°K	366°K	372°K		358°K	361°K	364°K
			CONDITION (1)			
314	332	348	IDLE - TAXI	1027	1053	1090
1045	1105	1161	TAKE OFF	1580	1620	1676
1045	1105	1161	CLIMB	1580	1620	1676
941	995	1045	CRUISE	1540	1579	1634
784	829	871	DESCENT	1454	1490	1543
732	773	876	MANEUVER	1391	1426	1476
993	1050	1103	LANDING	1517	1555	1609
1045	1105	1161	THRUST REVERSE	1517	1620	1676
314	332	348	IDLE - TAXI	1027	1053	1090

ENGLISH UNITS

UTW			OIL IN TEMPERATURES	OTW		
GALS/MIN				GALS/MIN		
185°F	200°F	210°F		185°F	190°F	195°F
			CONDITION (1)			
4.97	5.26	5.51	IDLE - TAXI	16.28	16.69	17.27
16.57	17.52	18.41	TAKE OFF	25.04	25.68	26.57
16.57	17.52	18.41	CLIMB	25.04	25.68	26.57
14.91	15.77	16.56	CRUISE	24.41	25.03	25.90
12.43	13.14	13.80	DESCENT	23.04	23.62	24.45
11.60	12.26	13.88	MANEUVER	22.04	22.60	23.39
15.74	16.64	17.48	LANDING	24.04	24.65	25.51
16.57	17.52	18.41	THRUST REVERSE	25.04	25.68	26.57
4.97	5.26	5.51	IDLE - TAXI	16.28	16.69	17.27

(1) TABLE 2-1 % POWER AND SPEEDS,
TABLE 2-3 100% CONDITIONS

TABLE 2-11a
 HEAT REJECTION (SI UNITS)
 (PRELIMINARY DESIGN PHASE)
 CLASS A (OTW) - MIL-L-23699 OIL

OIL IN TEMPERATURE	358°K			361°K			364°K		
	kW	Δ T°K	BULK TEMP. OUT, °K	kW	Δ T°K	BULK TEMP. OUT, °K	kW	Δ T°K	BULK TEMP. OUT, °K
CONDITION (1)									
IDLE - TAXI	13.90	7.39	365	13.93	7.22	368	14.04	7.06	371
TAKE-OFF	94.50	32.61	391	94.86	32.00	393	95.66	31.22	395
CLIMB	87.21	30.11	388	87.49	29.50	390	88.27	28.83	393
CRUISE	65.39	23.17	381	65.63	22.72	384	66.27	22.17	386
DESCENT	30.75	11.56	370	30.93	11.33	372	31.38	11.11	375
MANEUVER	47.81	18.72	377	48.87	18.72	380	49.31	18.28	382
LANDING	56.55	20.33	378	56.81	19.94	381	57.50	19.56	384
THRUST REVERSE	71.01	24.50	383	71.29	24.06	385	72.06	23.56	388
IDLE - TAXI	13.90	7.39	365	13.93	7.22	368	14.04	7.06	371

(1) TABLE 2-1 7% POWERS AND SPEEDS,
 TABLE 2-3 100% CONDITIONS.

TABLE 2-11b

HEAT REJECTION (ENGLISH UNITS)

(PRELIMINARY DESIGN PHASE)

CLASS A (OTW) - MIL-L-23699 OIL

OIL IN TEMPERATURE CONDITION (1)	185°F			190°F			195°F		
	BTU/MIN	Δ T°F	BULK TEMP. OUT, °F	BTU/MIN	Δ T°F	BULK TEMP. OUT, °F	BTU/MIN	Δ T°F	BULK TEMP. OUT, °F
IDLE - TAXI	791	13.3	198	793	13.0	203	799	12.7	208
TAKE-OFF	5383	58.7	244	5398	57.6	248	5444	56.2	251
CLIMB	4963	54.2	239	4979	53.1	243	5023	51.9	247
CRUISE	3721	41.7	227	3735	40.9	231	3771	39.9	235
DESCENT	1750	20.8	206	1760	20.4	210	1786	20.0	215
MANEUVER	2721	33.7	219	2781	33.7	224	2806	32.9	228
LANDING	3218	36.6	222	3233	35.9	226	3272	35.2	230
THRUST REVERSE	4041	44.1	229	4057	43.3	233	4101	42.4	237
IDLE - TAXI	791	13.3	198	793	13.0	203	799	12.7	208

(1) TABLE 2-1 % POWERS AND SPEEDS,

TABLE 2-3 100% CONDITIONS.

TABLE 2-12a
 HEAT REJECTION (SI UNITS)
 (PRELIMINARY DESIGN PHASE)
 CLASS B (UTW) - MIL-L-23699 OIL

OIL IN TEMPERATURE CONDITION (1)	358 °K			366 °K			372 °K		
	kW	Δ T °F	BULK TEMP. OUT °K	kW	Δ T °K	BULK TEMP. OUT °K	kW	Δ T °K	BULK TEMP. OUT °K
IDLE - TAXI	9.24	16.1	374	9.30	15.4	381	9.74	15.3	387
TAKE-OFF	58.34	30.4	388	58.87	29.3	395	59.45	28.2	400
CLIMB	53.42	27.8	386	53.95	26.8	393	54.51	25.9	398
CRUISE	39.59	22.9	381	40.00	22.1	389	40.47	21.3	413
DESCENT	17.63	12.3	370	17.91	11.9	378	18.22	11.6	384
MANEUVER	18.64	13.9	372	20.12	14.3	380	20.40	12.8	385
LANDING	33.63	18.4	376	34.09	17.8	384	34.58	17.3	380
THRUST REVERSE	42.58	22.2	380	43.09	21.4	387	42.35	20.1	392
IDLE - TAXI	9.24	16.1	374	9.30	15.4	381	9.74	15.3	389

(1) TABLE 2-1 % POWER AND SPEEDS,

TABLE 2-3 100% CONDITIONS.

TABLE 2-12b
 HEAT REJECTION (ENGLISH UNITS)
 (PRELIMINARY DESIGN PHASE)
 CLASS B (UTW) - MIL-L-23699 OIL

OIL IN TEMPERATURE CONDITION (1)	155°F			200°F			210°F		
	BTU/MIN	Δ T°F	BULK TEMP. OUT °F	BTU/MIN	Δ T°F	BULK TEMP. OUT, °F	BTU/MIN	Δ T°F	BULK TEMP OUT °F
IDLE - TAXI	526	28.9	214	529	27.7	228	554	27.5	238
TAKE-OFF	3320	54.8	240	3350	52.7	253	3383	50.8	261
CLIMB	3040	50.1	235	3070	48.3	248	3102	46.6	257
CRUISE	2253	41.3	226	2276	39.8	240	2303	38.4	284
DESCENT	1003	22.1	207	1019	21.4	221	1037	20.8	231
MANEUVER	1061	25.0	210	1145	25.7	226	1161	23.1	233
LANDING	1914	33.2	218	1940	32.1	232	1968	31.1	241
THRUST REVERSE	2423	40.0	225	2452	38.6	239	2410	36.2	246
IDLE - TAXI	526	28.9	214	529	27.7	228	554	27.5	238

(1) TABLE 2-1 % POWER AND SPEEDS,
 TABLE 2-3 100% CONDITIONS.

TABLE 2-13
 OVERALL GEAR BOX EFFICIENCY
 (PRELIMINARY DESIGN PHASE)

CLASS A (OTW) UNIT
 358°K (185°F) OIL IN TEMPERATURE
 MIL-L-23699 OIL
 SI UNITS

POWER kW	CONDITION (1)	kW LOSS BRGS	kW LOSS GEARS	kW LOSS CHURNING & WINDAGE	OVERALL EFFICIENCY %
2222	IDLE - TAXI	3.00	10.44	0.47	99.37
11111	TAKE-OFF	22.48	41.11	31.04	99.14
10000	CLIMB	22.30	37.00	27.94	99.12
7778	CRUISE	18.65	28.78	17.99	99.15
3333	DESCENT	13.22	12.33	5.21	99.07
6667	MANEUVER	12.34	26.00	9.49	99.28
6111	LANDING	19.69	22.00	14.89	99.07
7778	THRUST REVERSE	21.92	27.99	21.13	99.08
2222	IDLE - TAXI	3.00	10.44	0.47	99.37

ENGLISH UNITS

POWER HP	CONDITION (1)	HP LOSS BRGS	HP LOSS GEARS	HP LOSS CHURNING & WINDAGE	OVERALL EFFICIENCY %
2980	IDLE - TAXI	4.02	14.00	0.63	99.37
14900	TAKE-OFF	30.14	55.13	41.62	99.14
13410	CLIMB	29.91	49.62	37.46	99.12
10430	CRUISE	25.01	38.59	24.12	99.15
4470	DESCENT	17.73	16.54	6.99	99.07
8940	MANEUVER	16.55	34.87	12.73	99.28
8195	LANDING	26.40	29.50	19.97	99.07
10430	THRUST REVERSE	29.39	37.54	28.34	99.08
2980	IDLE - TAXI	4.02	14.00	0.63	99.37

(1) TABLE 2-1 % POWERS AND SPEEDS,
 TABLE 2-3 100% CONDITIONS.

TABLE 2-14

OVERALL GEAR BOX EFFICIENCY

(PRELIMINARY DESIGN PHASE)

CLASS A (OTW) UNIT

(190°F) OIL IN TEMPERATURE

MIL-L-23699 OIL

SI UNITS

POWER kW	BEARINGS LOSS kW	GEARS LOSS kW	WINDAGE & CHURNING LOSS kW	OVERALL EFFICIENCY %
2222	3.03	10.44	.47	99.37
11111	22.76	41.11	31.04	99.14
10000	22.59	37.00	27.93	99.12
7778	18.90	28.78	17.99	99.15
3337	13.39	12.33	5.21	99.07
667	12.50	26.67	9.73	99.26
61	19.94	22.00	14.89	99.07
7	22.20	27.99	21.13	99.08
3	3.03	10.44	.47	99.37

ENGLISH UNITS

CONDITION (1)	BEARINGS LOSS HP	GEARS LOSS HP	WINDAGE & CHURNING LOSS HP	OVERALL EFFICIENCY %
IDLE - TAXI	4.07	14.00	0.63	99.37
TAKE-OFF	30.52	55.13	41.62	99.14
CLIMB	30.30	49.62	37.46	99.12
30 CRUISE	25.34	38.59	24.12	99.15
470 DESCENT	17.95	16.54	6.99	99.07
8940 MANEUVER	16.76	35.76	13.05	99.26
8195 LANDING	26.74	29.50	19.97	99.07
10430 THRUST REVERSE	29.77	37.54	28.34	99.08
2980 IDLE - TAXI	4.07	14.00	0.63	99.37

(1) TABLE 2-1 % POWERS AND SPEEDS,
TABLE 2-3 100% CONDITIONS

TABLE 2-15

OVERALL GEAR BOX EFFICIENCY

(PRELIMINARY DESIGN PHASE)

CLASS A (OTW)

364°K (195°F) OIL IN TEMPERATURE

MIL-L-23699 OIL

SI UNITS

POWER kW	CONDITION (1)	BEARINGS LOSS kW	GEARS LOSS kW	WINDAGE & CHURNING LOSS kW	OVERALL EFFICIENCY %
2222	IDLE - TAXI	3.14	10.44	.47	99.36
11111	TAKE-OFF	23.55	41.11	31.04	99.13
10000	CLIMB	23.37	37.00	27.93	99.11
7778	CRUISE	19.53	28.78	17.99	99.14
3333	DESCENT	13.85	12.33	5.21	99.05
6667	MANEUVER	12.93	26.67	9.73	99.26
6111	LANDING	20.63	22.00	14.89	99.05
7778	THRUST REVERSE	22.97	27.99	21.13	99.07
2222	IDLE - TAXI	3.14	10.44	.47	99.36

POWER HP	CONDITION (1)	ENGLISH UNITS		WINDAGE & LOSS CHURNING HP	OVERALL %
		BEARINGS LOSS HP	GEARS LOSS HP		
2980	IDLE - TAXI	4.21	14.00	0.63	99.36
14900	TAKE-OFF	31.58	55.13	41.62	99.13
13410	CLIMB	31.34	49.62	37.46	99.11
10430	CRUISE	26.19	38.59	24.12	99.14
4470	DESCENT	18.57	16.54	6.99	99.05
8940	MANEUVER	17.34	35.76	13.05	99.26
8195	LANDING	27.66	29.50	19.97	99.05
10430	THRUST REVERSE	30.80	37.54	28.34	99.07
2980	IDLE - TAXI	4.21	14.00	0.63	99.36

(1) TABLE 2-1 % POWERS AND SPEEDS,
TABLE 2-3 100% CONDITIONS.

TABLE 2-16

OVERALL GEAR BOX EFFICIENCY

(PRELIMINARY DESIGN PHASE)
 CLASS B (UTW)
 358°K (185°F) OIL IN TEMPERATURE
 MIL-L-23699 OIL
 SI UNITS

POWER kW	CONDITION (1)	BEARINGS LOSS kW	GEARS LOSS kW	WINDAGE & CHURNING LOSS kW	OVERALL EFFICIENCY %
1849	IDLE - TAXI	0.95	8.14	0.16	99.50
9247	TAKE-OFF	9.82	32.36	16.18	99.36
8322	CLIMB	9.75	29.13	14.56	99.35
6473	CRUISE	7.88	22.65	9.06	99.38
2774	DESCENT	5.30	9.71	2.62	99.36
3329	MANEUVER	4.73	11.32	2.60	99.43
5086	LANDING	8.57	17.29	7.79	99.33
6473	THRUST REVERSE	9.58	22.00	11.01	99.34
1849	IDLE - TAXI	0.95	8.14	0.16	99.50

ENGLISH UNITS

POWER HP	CONDITION (1)	BEARINGS LOSS HP	GEARS LOSS HP	WINDAGE & CHURNING LOSS HP	OVERALL EFFICIENCY %
2480	IDLE - TAXI	1.27	10.91	0.22	99.50
12400	TAKE-OFF	13.17	43.40	21.70	99.36
11160	CLIMB	13.08	39.06	19.53	99.35
8680	CRUISE	10.57	30.38	12.15	99.38
3720	DESCENT	7.11	13.02	3.52	99.36
4464	MANEUVER	6.34	15.18	3.49	99.43
6820	LANDING	11.49	23.19	10.44	99.33
8680	THRUST REVERSE	12.85	29.51	14.76	99.34
2480	IDLE - TAXI	1.27	10.91	0.22	99.50

(1) TABLE 2-1 % POWERS AND SPEEDS,
 TABLE 2-3 100% CONDITIONS.

TABLE 2-17

OVERALL GEAR BOX EFFICIENCY

(PRELIMINARY DESIGN PHASE)

CLASS B (UTW)

366°K (200°F) OIL IN TEMPERATURE

MIL-L-23699 OIL

SI UNITS

POWER kW	CONDITION (1)	BEARINGS LOSS kW	GEARS LOSS kW	WINDAGE & CHURNING LOSS kW	OVERALL EFFICIENCY %
1849	IDLE - TAXI	1.00	8.14	0.16	99.49
9247	TAKE-OFF	10.34	32.36	16.18	99.36
8322	CLIMB	10.27	29.13	14.56	99.35
6473	CRUISE	8.30	22.65	9.06	99.38
2774	DESCENT	5.59	9.71	2.62	99.35
3329	MANEUVER	4.98	11.32	2.60	99.39
5086	LANDING	9.02	17.29	7.79	99.32
6473	THRUST REVERSE	10.09	22.00	11.01	99.33
1849	IDLE - TAXI	1.00	8.14	0.16	99.49

ENGLISH UNITS

POWER HP	CONDITION (1)	BEARINGS LOSS HP	GEARS LOSS HP	WINDAGE & CHURNING LOSS HP	OVERALL EFFICIENCY %
2480	IDLE - TAXI	1.34	10.91	0.22	99.49
12400	TAKE-OFF	13.87	43.40	21.70	99.36
11160	CLIMB	13.77	39.06	19.53	99.35
8680	CRUISE	11.13	30.38	12.15	99.38
3720	DESCENT	7.49	13.02	3.52	99.35
4464	MANEUVER	6.68	16.52	3.80	99.39
6820	LANDING	12.10	23.19	10.44	99.32
8680	THRUST REVERSE	13.53	29.51	14.76	99.33
2480	IDLE - TAXI	1.34	10.91	0.22	99.49

(1) TABLE 2-1 % POWER AND SPEEDS,
TABLE 2-3 100% CONDITIONS.

TABLE 2-18

OVERALL GEAR BOX EFFICIENCY

(PRELIMINARY DESIGN PHASE)

CLASS B (UTW)

372°K (210°F) OIL IN TEMPERATURE

MIL-L-23699 OIL

SI UNITS

POWER kW	CONDITION (1)	BEARINGS LOSS kW	GEARS LOSS kW	WINDAGE & CHURNING LOSS kW	OVERALL EFFICIENCY %
1849	IDLE - TAXI	1.05	8.51	0.17	99.47
9247	TAKE-OFF	10.92	32.36	16.18	99.35
8322	CLIMB	10.84	29.13	14.56	99.34
6473	CRUISE	8.76	22.65	9.06	99.37
2774	DESCENT	5.89	9.71	2.62	99.34
3329	MANEUVER	5.26	12.32	2.83	99.38
5086	LANDING	9.52	17.29	7.79	99.31
6473	THRUST REVERSE	10.65	22.65	9.06	99.34
1849	IDLE - TAXI	1.05	8.51	0.17	99.47

ENGLISH UNITS

POWER HP	CONDITION (1)	BEARINGS LOSS HP	GEARS LOSS HP	WINDAGE & LOSS CHURNING HP	OVERALL %
2480	IDLE - TAXI	1.41	11.41	0.23	99.47
12400	TAKE-OFF	14.64	43.40	21.70	99.35
11160	CLIMB	14.54	39.06	19.53	99.34
8680	CRUISE	11.75	30.38	12.15	99.37
3720	DESCENT	7.90	13.02	3.52	99.34
4464	MANEUVER	7.05	16.52	3.80	99.38
6820	LANDING	12.77	23.19	10.44	99.31
8680	THRUST REVERSE	14.28	30.38	12.15	99.34
2480	IDLE - TAXI	1.41	11.41	0.23	99.47

(1) TABLE 2-1 % POWERS AND SPEEDS,
TABLE 2-3 100% CONDITIONS.

Bearing size, cubic mean load, mean speed, rpm, and B_1 life in hours using catalog dynamic capacity "C" values, for both Class A (OTW) and Class B (UTW) flight cycle operation and test engine cycle operation are presented in Table 2-19. Bearing B_1 life is obtained by applying a material factor of 5 and a life conversion factor of 0.23 to the calculated AFBMA B_{10} life. For the submitted preliminary design flight duty cycle the bearings did not satisfy the specification requirements of a B_1 bearing life of no less than 6,000 hours for both Class A (OTW) and Class B (UTW) gear assemblies. Need for refinement of the flight duty cycle definition and the maximum attainable "C" value for the bearings was indicated.

An AGMA gear scoring index for Class A (OTW) and Class B (UTW) experimental engine cycles was calculated and is presented in Table 2-20 for the power and speeds from Table 2-4.

A preliminary weight analysis was made for Class A (OTW) gear assembly based on layout LS 34808 Sheet 2, Figure 2-1, and for Class B (UTW) gear assembly per LS 34808 Sheet 1, Figure 2-2. Results are tabulated in Table 2-21.

As discussed earlier, the stress analysis of the gears included calculation of gear tooth bending and contact stresses by the standard AGMA methods and comparison to allowable AGMA values as well as values based on C-W experience. In addition, rim stresses were calculated for each gear element. The rim is loaded by centrifugal forces, radial forces and bending moments in the plane of the ring. Shear stresses were included where they exist. Simplifying conservative assumptions were made throughout the analysis. Each load was analyzed separately and the results superimposed. In this way, the various loading effects could be investigated separately. Stresses are divided into steady and vibratory stresses and plotted on Goodman diagrams for the respective materials. Although the maximum gear tooth bending stress and the maximum rim stress do not occur at the same location, there is some influence of one on the other. A method of combining these stresses is used to show that the gear elements will perform satisfactorily.

TABLE 2-19

BEARING DATA

(PRELIMINARY DESIGN PHASE)

TYPE: SPHERICAL ROLLER BEARINGS

MATERIALS: OUTER RACE (AMS 6265) (SAE 9310)

ROLLERS AND INNER RACE (M50)

GEAR UNIT	CLASS A (OTW)		CLASS B (UTW)	
Bearing Size	22312		22314	
	<u>SI</u>	<u>ENGLISH</u>	<u>SI</u>	<u>ENGLISH</u>
Capacity, "C"	197,500 N	44,400 LBS	248,600 N	55,900 LBS
<u>FLIGHT CYCLE</u>				
Cubic Mean Load	19,669 N	4,422 LBS	24,753 N	5,565 LBS
Mean Speed	1130 rad/s	10,793 RPM	797 rad/s	7,611 RPM
B1 Life		3,877 HRS		5,506 HRS
<u>TEST ENGINE CYCLE</u>				
Cubic Mean Load	20,563 N	4,623 LBS	25,875 N	5,817 RPM
Mean Speed	492.5 rad/s	9,406 RPM	347 rad/s	6,629 RPM
B1 Life		3,838 HRS		5,444 HRS

TABLE 2-20

SCORING INDEX (AGMA)
 (EXPERIMENTAL ENGINE CYCLE)
 (TABLE 2-4 POWER AND SPEED)

CLASS B (UTW)	TEST CONDITION		CLASS A (OTW)
$\Delta T^{\circ}F$	% FAN SPEED	% FAN HP	$\Delta T^{\circ}F$
97	105	100	118
126	100	140	154
119	100	130	145
105	100	110	128
98	100	100	119
85	90	80	104
63	75	50	76
24	30	10	29

MAX PERMISSIBLE SCORING INDEX $T_f = 300^{\circ}F = (\text{OIL IN TEMPERATURE} + \Delta T)$

TABLE 2-21

PRELIMINARY DESIGN WEIGHT ANALYSIS

	CLASS A (OTW)		CLASS B (UTW)	
	kg	lbs	kg	lbs
STAR GEAR SUPPORT	30.24	66.67	31.76	70.01
STAR GEAR ASSY.	35.56	78.40	37.56	82.80
SUN GEAR ASSY.	9.25	20.40	7.96	17.54
RING GEAR	<u>9.89</u>	<u>21.80</u>	<u>11.76</u>	<u>25.92</u>
TOTAL WEIGHT	84.94	187.27	89.04	196.27

A stress analysis of the star gear carrier support was made for the normal torque loads as well as the loads due to expected maneuver conditions during flight and landing. Abnormal loading caused by fan unbalance due to blade failure was applied in addition to the normal torque loads, and the carrier support was found to be acceptable.

The star gear carrier support and the flexible coupling were stress-analyzed by means of a detailed shell computer program capable of calculating axisymmetric and non-axisymmetric loading conditions. In addition to centrifugal forces and torques the coupling had loads from the sun gear due to vehicle maneuvers during flight and landing. Maneuver and blade out loads were obtained from a complete system dynamic analysis performed by G.E. The analysis furnished deflection values at specific locations in the system that were converted to forces by calculating the associated spring values of the elements involved.

In an epicyclic reduction gear unit, input torque is transmitted along the pitch diameter line of the sun gear and output torque is transmitted along the pitch diameter line of the ring gear. Under load the sun and ring gear will deflect. In order to insure uniform gear tooth loading at each mesh, deflections of the mating teeth must be controlled. The star gear will assume a position such that the forces acting along the line of contact for the sun gear mesh and the ring gear mesh result in a balanced moment system. Final position of the star gear as dictated by the sun and ring gear deflections should "match" the deflection of the carrier support post on which the inner race of the star gear bearing is mounted. A good "match" can be achieved by a proper selection of geometry of the gear tooth rim supports and the location and orientation of the three gear elements, sun, ring and star.

Figure 2-4 shows a simplified isometric sketch of the gear mesh. The loads on the ring gear due to centrifugal forces and mesh separating forces, will cause the ring gear to deflect outward resulting in a slope of the ring gear in that direction. The separating force will cause the unsupported end of the ring gear to deflect further outward. The pressure angle of the gear tooth causes the ring to have in effect a circumferential movement in a clockwise direction. The sketch shows this as a gap between the star and ring tooth.

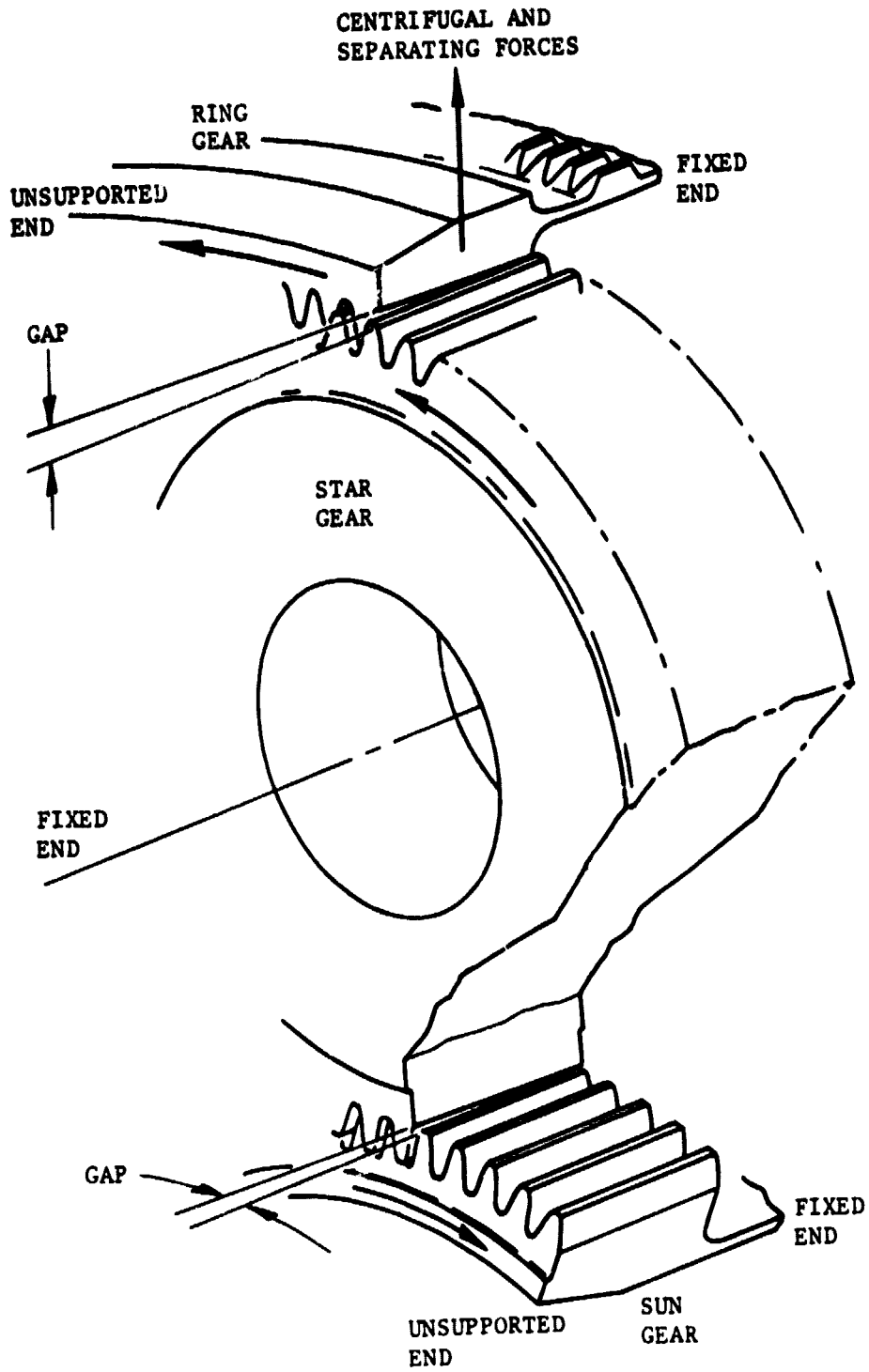

ORIGINAL PAGE IS
OF POOR QUALITY

Figure 2.4 Gear Mesh Deflections

For the sun gear, the separating force has a greater effect than the centrifugal force. The resulting slope of the sun gear at the unsupported end is inward toward the center line. Because of the gear tooth pressure angle this radial movement would leave a clockwise gap at the forward end of the sun gear. The two gaps just discussed would exist if the star gear deflection is assumed zero.

Loading on the star gear results in a tangential load at its center which acts on the carrier support trunnion and a third deflection must then be evaluated. Because the carrier support is fixed and the tangential load is in the direction tangent to the sun gear rotation at the mesh, the deflection of the trunnion will be in the direction to reduce the ring and sun gear gaps shown. The spherical bearing will permit the star to rotate slightly to completely match the deflections of the sun and ring gear.

3.0 DETAILED DESIGN - UTW REDUCTION GEAR

3.1 Mechanical Design

Results of the preliminary design phase were integrated into the General Electric Company overall QCSEE program and after a series of updating and exchanges of results, the flight cycle design objectives shown in Table 3-1 were established for the UTW unit detailed design. Additional design objectives for experimental engine operation are shown in Table 3-2. Final configuration of the UTW gear assembly is defined by Figures 3-1 (assembly), 3-2 (involute gear tooth layout) and 3-3 (involute spline layout). Gear speed and bearing load data at the 100% power, 100% speed take-off conditions are shown in Table 3-3. Basic size at 100% is 9785 kW (13,116 hp) output with an output speed of 3143 rpm and a gear ratio of 2.465:1 (7747 rpm input speed). Bill of Material No. 210 is included as Appendix A. Basic gear data, stresses and materials are shown in Table 3-4. Details of the gear tooth involute profile modifications for the sun gear, star gear and ring gear are shown by Figures 3-4, 3-5 and 3-6, respectively. Gear material stresses presented in Table 2-8 are applicable to the final design. Calculated stresses expected during the experimental engine test operation are shown in Table 3-5.

The maximum bending stress of $34,819 \text{ N/cm}^2$ (50,500 psi) occurs in the sun gear during the 140% turbine power specified for one hour during the experimental engine operation, a total of approximately 2.8×10^6 cycles. This is lower than the AGMA allowable stress of $38,691 \text{ N/cm}^2$ (56,117 psi) for AMS 6265 material under single direction loading, Table 2-8. The maximum bending stress in the star gear of $33,653 \text{ N/cm}^2$ (48,810 psi) occurs during the same operation noted above for the sun gear. Although this stress is greater than the AGMA allowable of $26,958 \text{ N/cm}^2$ (39,100 psi) for loading in both directions, Table 2-8, it occurs for only 6.4×10^5 cycles and is acceptable. The maximum contact stress of $103,456 \text{ N/cm}^2$ (150,050 psi) occurring in the sun to star gear mesh is only slightly greater than the AGMA allowable of $102,566 \text{ N/cm}^2$ (148,760 psi) shown in Table 2-8 and, considering the small number of cycles, is acceptable. The maximum ring gear stresses are well below the AGMA allowables.

TABLE 3-1
 CLASS B (UTW) REDUCTION GEAR
 DETAIL DESIGN OBJECTIVES
 FLIGHT CYCLE

CONDITION	POWER %	SPEED %	TIME %	OIL IN TEMP.	
				*K	*F
START	0	0-30	1.11	---	---
IDLE	10	66.81	6.89	363	194
TAKE-OFF	100	100	2.71	366	200
CLIMB	85.15	102.19	22.22	369	205
CRUISE	68.92	102.99	31.11	383	230
DESCENT	3.27	34.489	22.22	403	266
APPROACH	61.23	97.805	6.67	370	207
REVERSE	62.46	109.672	0.18	364	195
IDLE	10	66.81	6.89	363	194
100% FAN POWER = 9781 kW (13116 hp)					
100% FAN SPEED = 329 rad/s (3143 rpm)					

TABLE 3-2
 CLASS B (UTW) REDUCTION GEAR
 DETAIL DESIGN OBJECTIVES
 EXPERIMENTAL ENGINE CYCLE

HOURS	% TIME	% TURBINE SPEED	% TURBINE POWER
1	0.04	105	100
1	0.04	100	140
15	0.56	100	130
15	0.56	100	110
150	5.59	100	100
500	18.64	90	80
1000	37.28	75	50
1000	37.28	30	10
100% Turbine Power = 9885 kW (13256 hp)			
100% Turbine Power = 811 rad/s (7747 rpm)			

ORIGINAL PAGE IS
OF POOR QUALITY

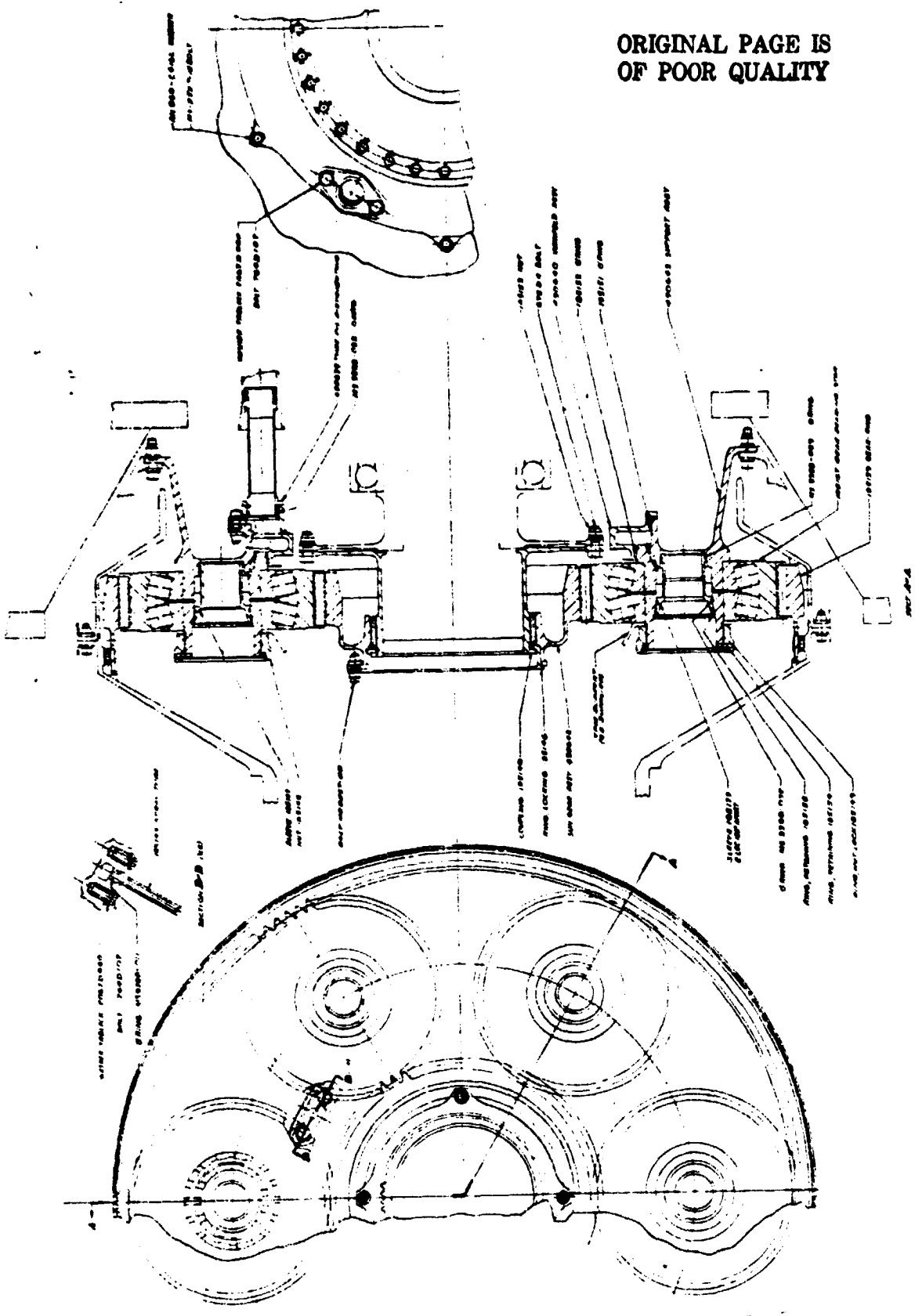
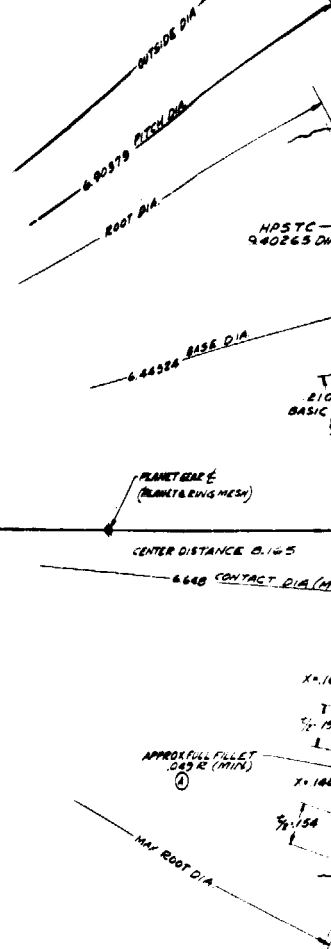
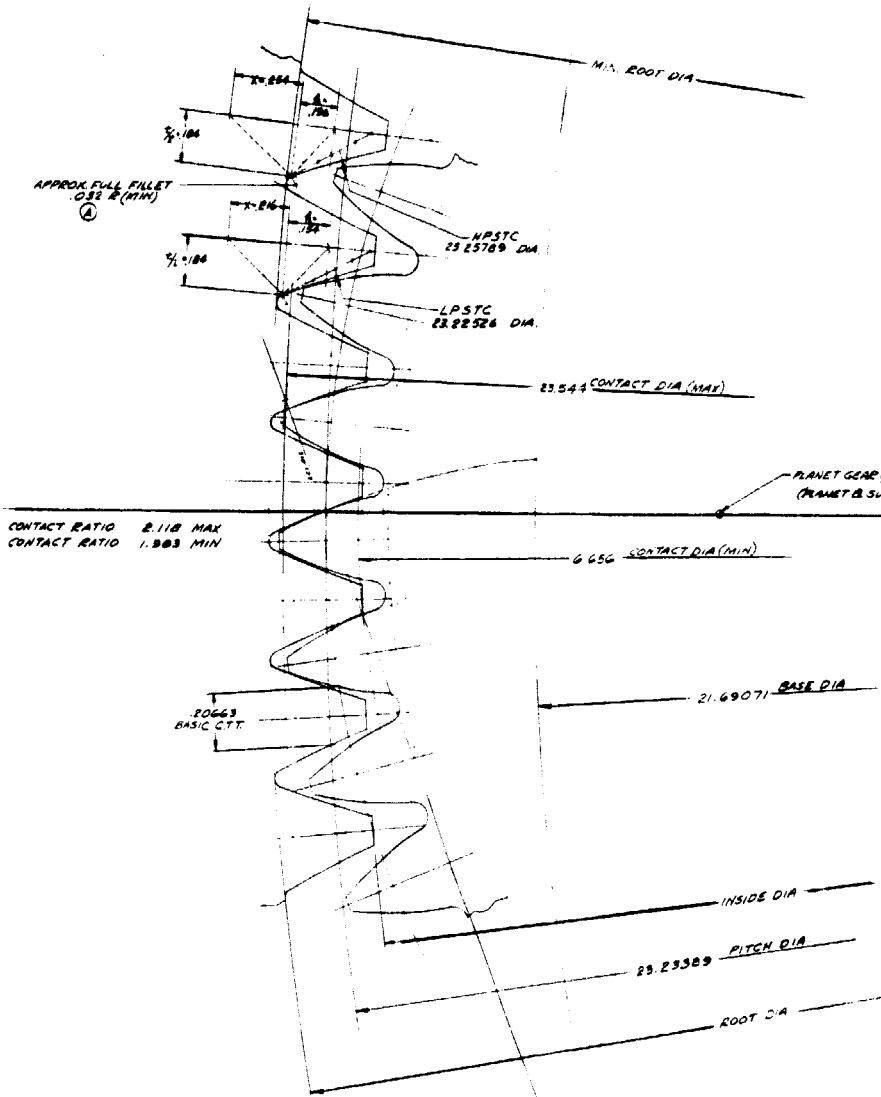

Figure 3-1. QCSEE Main Reduction Gear Under-The-Wing (UTW) Unit.

FOLDOUT DRAWING

ORIGINAL PAGE IS OF POOR QUALITY



ORIGINAL PAGE IS OF POOR QUALITY

ORIGINAL PAGE OF POOR QUALITY

WELDOUT FRAME
J

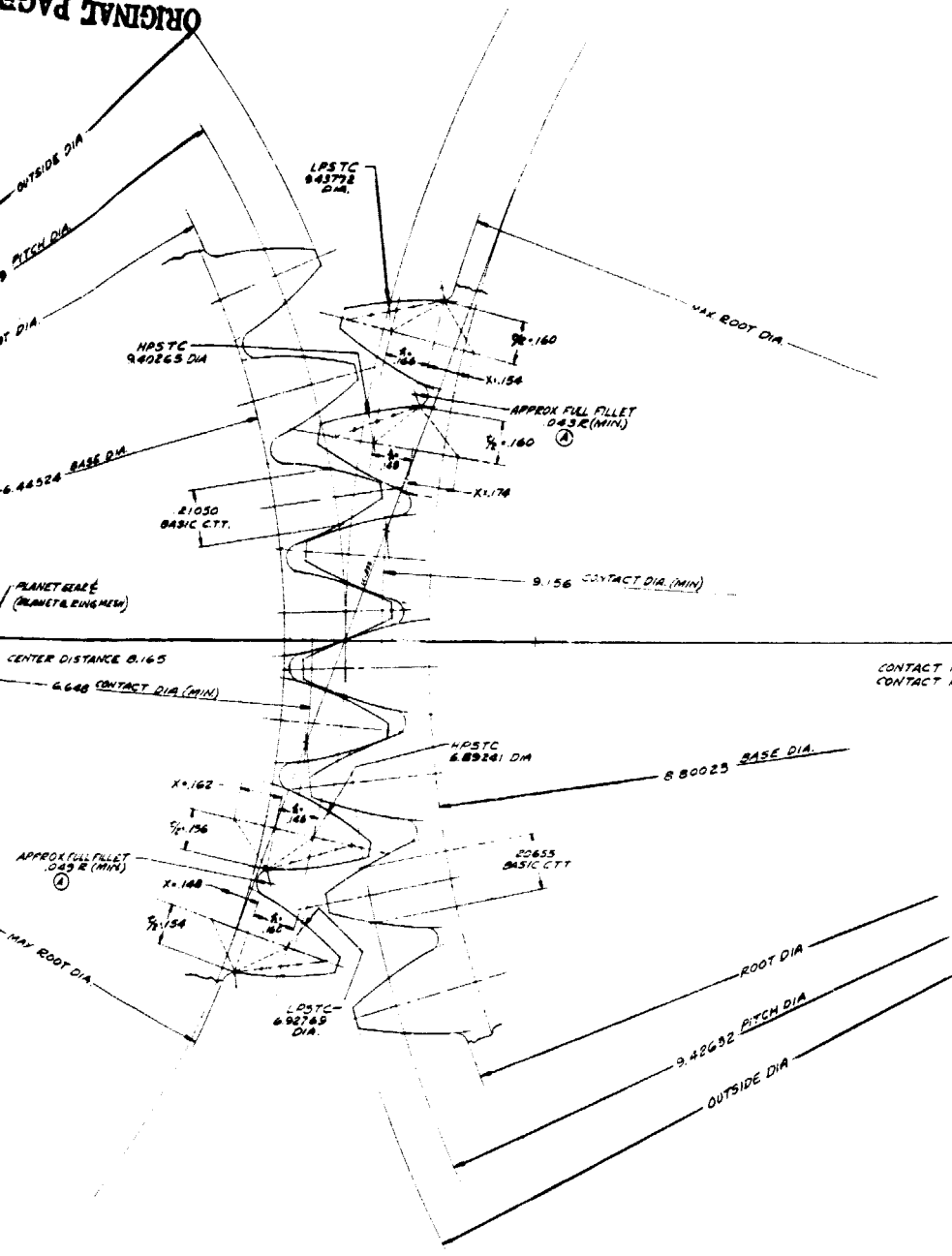

DETAIL GEAR DATA				
	SUN	27E	27S	
N	NUMBER OF TEETH	7	52	75
P	DIAMETRAL PITCH	7.5921	7.5921	7.5921
Φ	PRESSURE ANGLE	21°	21°	21°
CD	PITCH DIAMETER	5.42432	4.90379	29.23589
CO	CENTER DISTANCE	8.165	8.165	8.165
T	TOOTH THICKNESS	.20655	.21050	.20663
T	MACH TOOTH THK	.20255	.20450	.20163
BL	BACK LASH	.004-.006	.004-.006	.005-.008
PO	BASE PITCH	38939	38888	38939
DB	BASE DIA	6.80023	6.44524	21.69071
W	WIRE SIZE	0.2407	0.2407	0.2407
M	OVER WIRE MEAS	9.7733	7.2612	22.8781
		9.7685	7.2565	22.8828
DO	OUTSIDE DIA (1.0 FOR INT GEAR)	9.748	7.249	22.958
		9.741	7.248	22.948
DR	ROOT DIA	8.992	6.480	23.674
		8.937	6.445	23.648
FR	FILLET RADIUS	.043 (MIN)	.039 (MIN)	.032 (MIN)
BR	OD ROLL #	27.27	29.51	19.87
BP	HPSTC ROLL #	21.56	21.71	22.17
BR	PITCH DIA ROLL #	21.99	21.99	21.99
BR	LPSTC ROLL #	22.20	22.50	21.99
BR	CONTACT DIA ROLL #	16.46	14.48	24.19
RG	RUN OUT	.002	.001	.0035
	TOOTH TO TOOTH SPACING	.0002	.002	.0005
	PROFILE TOLERANCE	#	#	#
	LEAD	.003	.003	.008
	BEAR FACE (INCHES)	1.836	2.030	1.806
	TIP BEAR EDGE	.01 (MAX)	.01 (MAX)	.01 (MAX)
	PROTUBERANCE	.001-.008	.001-.008	.005-.008

* SEE INVOLUTE CHART FOR TOL.

ORIGINAL PAGE IS OF POOR QUALITY

CLASS B (UTW) REDUCTION GEAR
Gear Layouts

Figure 3-2

FOLD OVER FRAME

ORIGINAL PAGE IS OF POOR QUALITY

EXTERNAL SPLINE
24.6086 - 24.6334 MEASUREMENT OVER 2 PINS (REF)
.144 PIN DIA

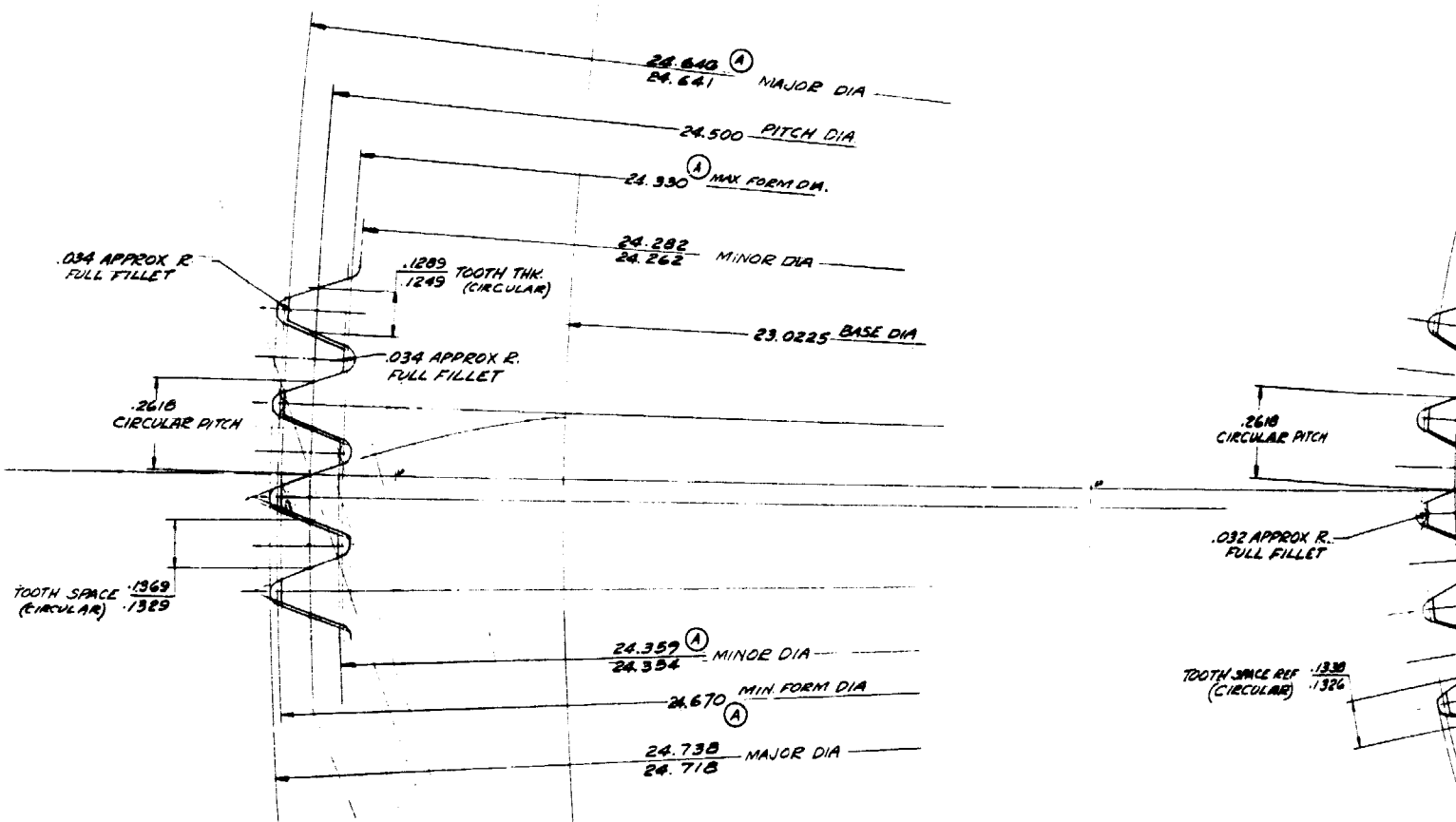

INTERNAL SPLINE
24.3108 - 24.2996 MEASUREMENT OVER PINS (REF)
.144 PIN DIA

RING GEAR
INVOLUTE SPLINE
294 TEETH
12 PITCH (FULL DEPTH)
20° PRESSURE ANGLE
SPEC 9070 & 9080
.004-.012 BACKLASH

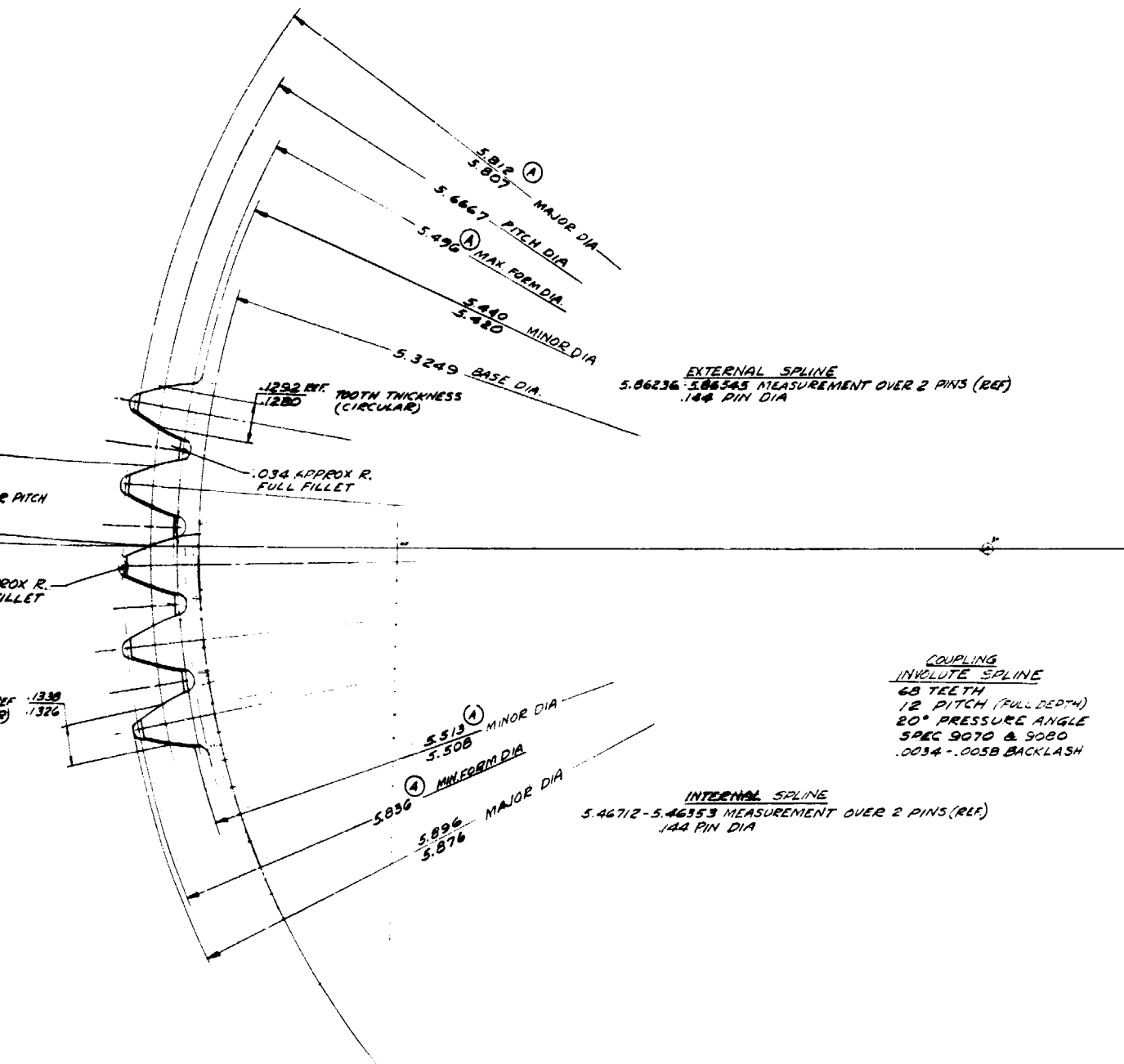

COUPLING
INVOLUTE SPLINE
68 TEETH
12 PITCH (FULL DEPTH)
20° PRESSURE ANGLE
SPEC 9070 & 9080
.0034 - .0058 BACKLASH

Early Domestic Disinformation Legend

Because of its possible commercial value, this data furnished under U.S. Government contract DDAG-10000 is being disseminated within the U.S. in absence of general publication. This data may be disseminated and used by the recipient with the express understanding that the data will not be published nor will it be reproduced outside the recipient's domestic organization without express permission of General Electric Company. The information contained in this legend will be considered void after January 1, 1958. This legend shall be marked on any reproduction of this data in whole or in part.

CLASS B (UTW) REDUCTION GEAR
Spline Layouts
Figure 3-3

TABLE 3-3

CLASS B (UTW) REDUCTION GEAR CHARACTERISTICS
AND 100% POWER, 100% SPEED DATA

	NON-DIMENSIONAL	SI UNITS	ENGLISH UNITS
RATIO	2.465		
TURBINE POWER		9885 kw	13256 hp
TURBINE SPEED		811 rad/s	7747 rpm
GEAR PITCH LINE VELOCITY		97.1 m/s	19117 ft/min
STAR SPEED		1108 rad/s	10577 rpm
BEARING LOAD		33927 N	7627 lbs
NO. OF STARS	6		
SUN GEAR TEETH	71		
STAR GEAR TEETH	52		
RING GEAR TEETH	175		
HUNTING	YES		
NON FACTORIZING	YES		

TABLE 3-4a
 CLASS B (UTW) REDUCTION GEAR
 GEAR DATA (SI UNITS)

	SUN GEAR	STAR GEAR	RING GEAR
NO. OF TEETH	71	52	175
MODULE	3.3722	3.3722	3.3722
PRESSURE ANGLE, DEGREES	21	21	21
PITCH DIAMETER, MM	239.43	175.36	590.14
CENTER DISTANCE, MM	207.39	207.39	
BASE DIA., MM	223.526	163.709	550.944
TOOTH THICK (PD), MM	5.2464	5.3467	5.2484
BACKLASH, MM	.102-.152	.102-.152	.127-.203
ROOT RAD., MM	1.17 (MIN.)	1.35 (MIN.)	.89 (MIN.)
CONTACT RATIO (MIN.) (NO BREAK EDGES)	2.12688	2.11796	
CONTACT RATIO (MIN.) (MAX. BREAKEDGES)	2.01047	1.98347	
GEAR FACE WIDTH, MM	47.1	51.5	45.9
BENDING STRESS, N/cm ² (100% POWER & SPEED)	24,869	24,042	19,595
CONTACT STRESS, N/cm ² (100% POWER & SPEED)	87,329	87,329	56,461
MATERIAL	AMS6265 (SAE9310)	AMS6265 (SAE9310)	AMS6470
PROFILE CORRECTION	Fig. 3-4	Fig. 3-5	Fig. 3-6

TABLE 3-4b

CLASS B (UTW) REDUCTION GEAR

GEAR DATA (ENGLISH UNITS)

	SUN GEAR	STAR GEAR	RING GEAR
NO. OF TEETH	71	52	175
DIAMETRAL PITCH	7.5321	7.5321	7.5321
PRESSURE ANGLE, DEGREES	21	21	21
PITCH DIAMETER, IN.	9.4263	6.9038	23.2339
CENTER DISTANCE, IN.		8.165	8.165
BASE DIA., IN.	8.80023	6.44524	21.69071
TOOTH THICK (PD), IN.	.20655	.21050	.20663
BACKLASH, IN.	.004-.006	.004-.006	.005-.008
ROOT RAD., IN.	.046 (MIN.)	.053 (MIN.)	.035 (MIN.)
CONTACT RATIO (MIN) NO BREAK EDGES		2.12688	2.11796
CONTACT RATIO (MIN) (.010 MAX. BREAK EDGES)		2.01047	1.98347
GEAR FACE WIDTH - IN.	1.856	2.03	1.806
BENDING STRESS, PSI (100% POWER & SPEED)	36,070	34,870	28,420
CONTACT STRESS, PSI (100% POWER & SPEED)	126,660	126,660	81,890
MATERIAL	AMS6265 (SAE9310)	AMS6265 (SAE9310)	AMS6470
PROFILE CORRECTION	Fig. 3-4	Fig. 3-5	Fig. 3-6

ORIGINAL PAGE IS
OF POOR QUALITY

CLASS B (UTW) REDUCTION GEAR
SUN GEAR
INVOLUTE PROFILE MODIFICATION

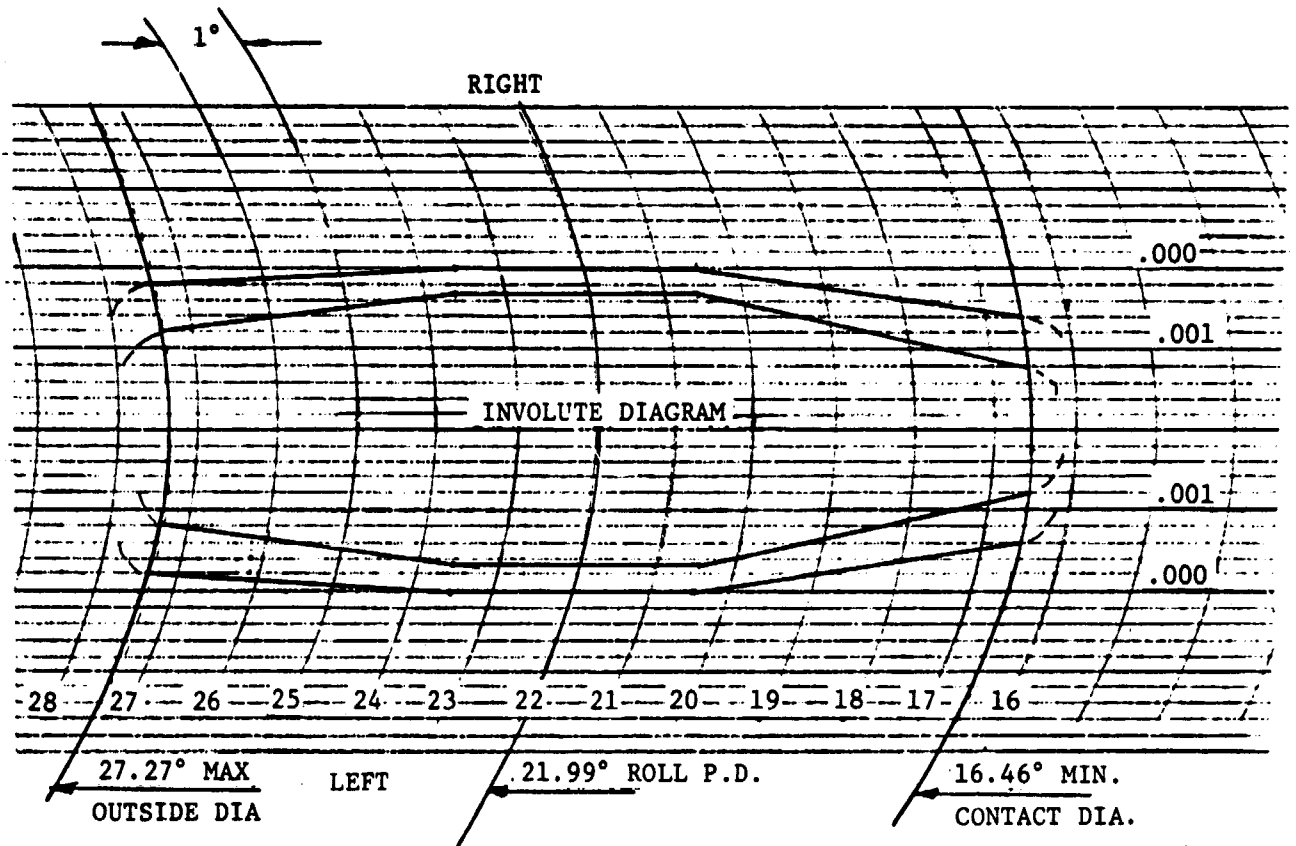

Figure 3-4

ORIGINAL PAGE IS
OF POOR QUALITY

CLASS B (UTW) REDUCTION GEAR
STAR GEAR
INVOLUTE PROFILE MODIFICATION

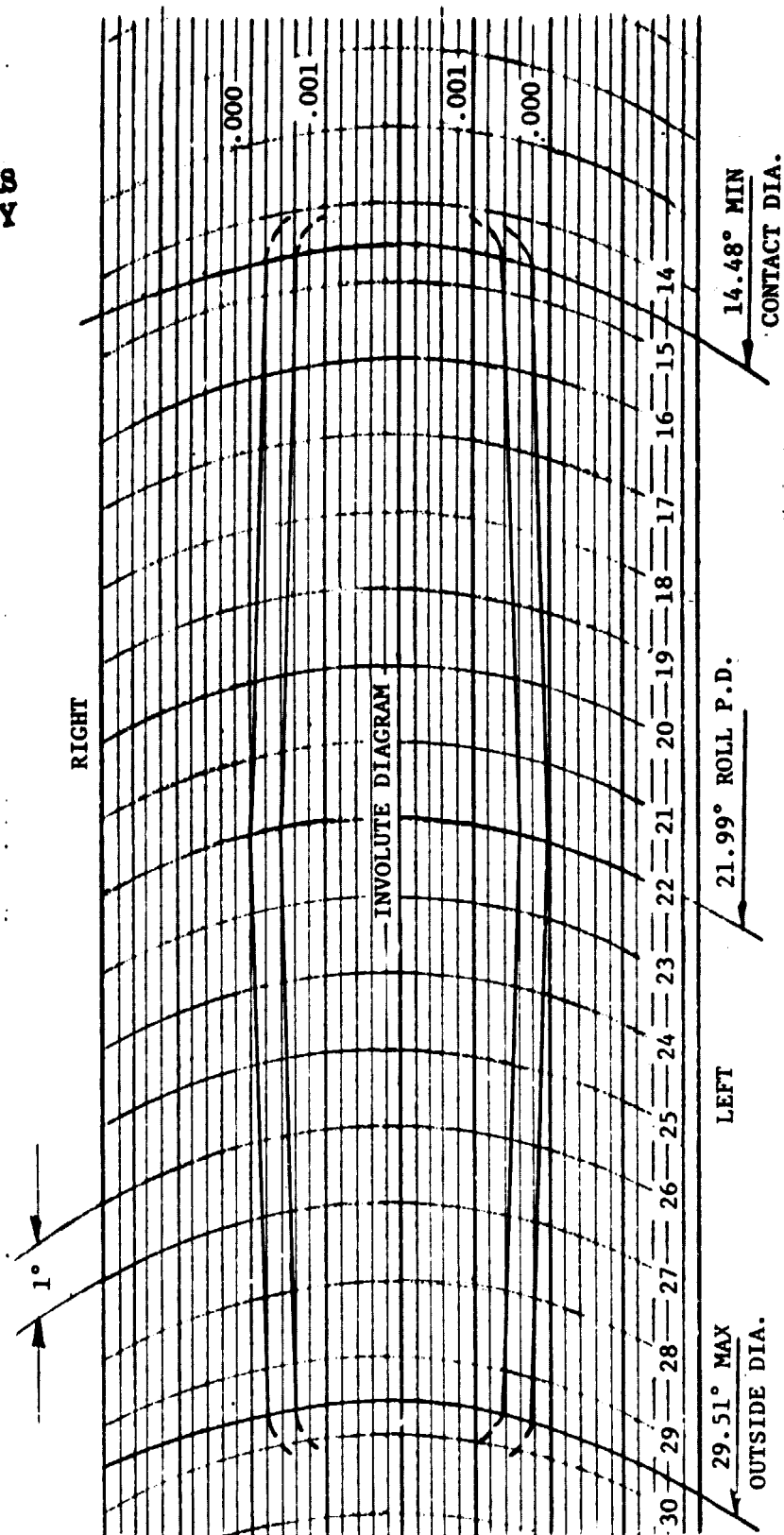

Figure 3-5

ORIGINAL PAGE IS
OF POOR QUALITY

CLASS B (UTW) REDUCTION GEAR
RING GEAR
INVOLUTE PROFILE MODIFICATION

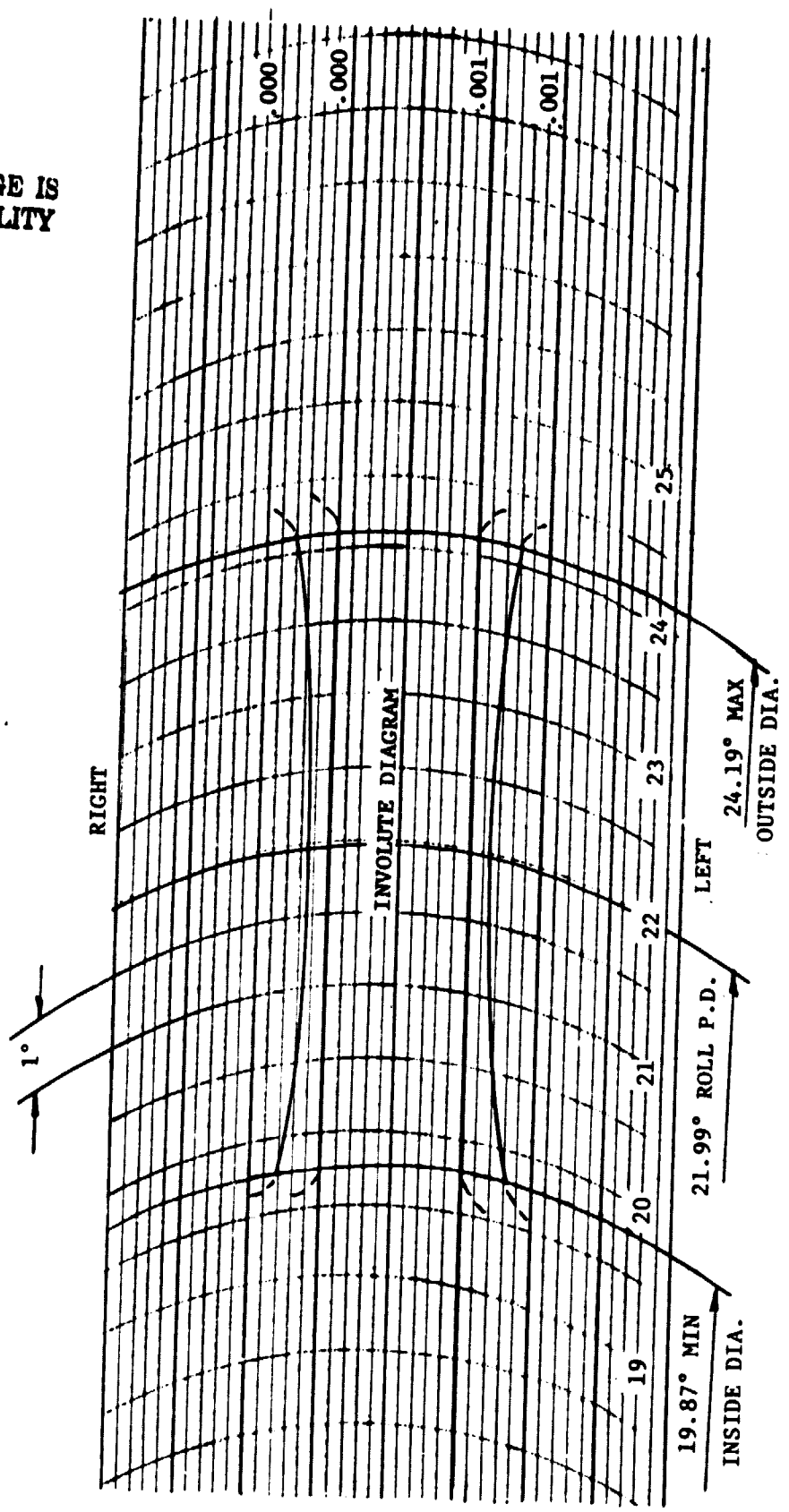

Figure 3-6

TABLE 3-5

CLAS. B (UTW) REDUCTION GEAR

GEAR STRESS DATA

EXPERIMENTAL ENGINE TEST OPERATION

(SI UNITS)

TURBINE SPEED rad/s	TURBINE POWER kW	BENDING STRESS - N/cm ²			CONTACT STRESS - N/cm ²	
		SUN	STAR	RING	SUN/STAR	STAR/RING
851.8	9,885					
811.3	13,780	34,819	33,653	26,731	103,456	65,893
811.3	12,796	32,330	31,247	2,482	99,691	63,121
811.3	10,828	27,358	26,441	21,001	91,700	58,412
811.3	9,885	24,869	24,035	19,595	87,329	56,461
730.1	7,875					
608.4	4,922					
243.4	984					

(ENGLISH UNITS)

TURBINE SPEED RPM	TURBINE POWER HP	BENDING STRESS-PSI			CONTACT STRESS - PSI	
		SUN	STAR	RING	SUN/STAR	STAR/RING
8,134	13,256					
7,747	18,480	50,500	48,810	38,770	150,050	95,570
7,747	17,160	46,890	45,320	3,600	144,590	91,550
7,747	14,520	39,680	38,350	30,460	133,000	84,720
7,747	13,256	36,070	34,860	28,420	126,660	81,890
6,972	10,560					
5,810	6,600					
2,324	1,320					

The star gear bearing is a double row spherical roller type with cage-guided symmetrical rollers. The bearing outer race is integral with the star gear. Lubrication of the bearing is through radial passages in the center of the inner race. Detailed data for the bearing are shown in Table 3-6. The bearing calculated mean load, mean speed and resultant B_1 fatigue life of 6110 hours for the flight spectrum (Table 3-1) and 5780 hours for the experimental engine operation schedule (Table 3-2) are shown in Table 3-7. The life values are based on the standard AFBMA life calculation method for roller bearings with a multiplying factor of 0.23 applied to convert from B_{10} to B_1 life and a factor of 5 applied for material, operating environment and oil jet lubrication. A section through the bearing which also shows the oil passages appears in Figure 3-1.

Oil flows for the reduction gears and bearings for the flight duty cycle are presented in Table 3-8. These flows are based on a variable oil supply pressure which is a function of core engine speed. The estimated effective oil supply pressures, temperatures and available flows at the reduction gear inlet for the several engine operating conditions as supplied by General Electric are shown in Table 3-9. Maximum limit for the bearing outer race temperature has been established at 422°K (300°F). Calculated maximum bearing outer race temperature occurs during the cruise condition in the flight cycle. The required oil flow together with the effective oil pressure at this flight condition establishes the bearing oil flow control orifice size. The controlling flight condition for oil flow to the gears based on gear scoring criteria is take-off. Orifice sizes in the gear spray bars are based on this requirement. Oil inlet temperatures shown in Tables 3-8 and 3-9 are the result of General Electric heat balance iterations for the reduction gear and UTW engine.

Table 3-10 tabulates the overall UTW reduction gear efficiency for the flight duty cycle. Losses considered in calculating the efficiency are the spherical bearing loss, gear mesh loss and windage and churning losses. At the take-off condition, the calculated overall efficiency is 99.3 percent which is greater than the M50TF1611 specification of 99.2 percent for the 100 percent speed and 100 percent power operating condition.

TABLE 3-6
 CLASS B (UTW) REDUCTION GEAR
 BEARING DATA

VENDOR, PART NO.	SKF 22314 VAR
TYPE	DOUBLE ROW SPHERICAL ROLLER (SPECIAL)
NO. OF ROLLERS (PER ROW)	14
SIZE OF ROLLERS	20.5 mm X 19.65 mm
DYNAMIC CAPACITY, "C"	255,800 N (57,500 LBS.)
MATERIALS:	
OUTER RING (INTEGRAL WITH GEAR)	CARBURIZED AMS6265, Rc 60-63
INNER RING	CVM M-50 STEEL, Rc 60 MIN.
ROLLERS	CVM M-50 STEEL, Rc 60 MIN.
CAGE	AMS4616, SILVER PLATED

TABLE 3-7
 CLASS B (UTW) REDUCTION GEAR
 BEARING LIFE DATA

FLIGHT CYCLE		
MEAN LOAD (10/3 EXP.)	23807 N	5352 lbs
MEAN SPEED	898 rad/s	8573 rpm
B-1 LIFE	6110 hrs	
EXPERIMENTAL ENGINE CYCLE		
MEAN LOAD (10/3 EXP.)	26147 N	5878 lbs
MEAN SPEED	694 rad/s	6629 rpm
B-1 LIFE	5780 hrs	

TABLE 3-8
 CLASS B (UTW) REDUCTION GEAR
 TOTAL OIL FLOWS
 FLIGHT CYCLE
 (SI UNITS)

CONDITION	TOTAL STAR BRG. FLOW, cm ³ /s	FLOW TO GEARS (SPRAY BARS), cm ³ /s	TOTAL OIL FLOW cm ³ /s	OIL IN °K	BRG OUTER RACE TEMP. °K
IDLE	379	673	1052	363	385
TO	502	887	1389	366	407
CLIMB	493	896	1389	369	410
CRUISE	490	898	1388	383	422
DESCENT	397	706	1104	403	410
APPROACH	464	858	1322	370	409
REVERSE	481	878	1359	364	410
IDLE	379	673	1052	363	385

(ENGLISH UNITS)

CONDITION	TOTAL STAR BRG. FLOW, GAL/MIN	FLOW TO GEARS (SPRAY BARS), GAL/MIN	TOTAL OIL FLOW, GAL/MIN	OIL IN °F	BRG OUTER RACE TEMP °F
IDLE	6.00	10.66	16.66	194	234
TO	7.95	14.067*	22.02	200	273
CLIMB	7.82	14.199	22.02	205	279
CRUISE	7.77*	14.231	22.00	230	300
DESCENT	6.30	11.196	17.50	266	278
APPROACH	7.35	13.595	20.95	207	276
REVERSE	7.62	13.924	21.54	195	278
IDLE	6.00	10.66	16.66	194	234
*CONTROLLING CONDITION					

TABLE 3-9
 CLASS B (UTW) REDUCTION GEAR
 OIL SUPPLY DATA
 (SI UNITS)

CONDITION	MAX. OIL TEMP. - °K	AVAILABLE OIL FLOW - cm ³ /s	OIL PRESSURE N/cm ²
IDLE	363	1129	15.2
TAKE-OFF	366	1514	27.6
CLIMB	369	1502	26.9
CRUISE	383	1451	25.5
DESCENT	403	1129	15.2
APPROACH	370	1394	23.4
REVERSE	364	1483	26.2

(ENGLISH UNITS)

CONDITION	MAX OIL TEMP. - °F	AVAILABLE OIL FLOW - GPM	OIL PRESSURE PSI
IDLE	194	17.9	22
TAKE-OFF	200	24.0	40
CLIMB	205	23.8	39
CRUISE	230	23.0	37
DESCENT	266	17.9	22
APPROACH	207	22.1	34
REVERSE	195	23.5	38

TABLE 3-10
 CLASS B (UTW) REDUCTION GEAR
 OVERALL REDUCTION GEAR EFFICIENCY
 FLIGHT CYCLE
 (SI UNITS)

CONDITION	POWER LOSS - kW				OVERALL EFFICIENCY %
	SPHERICAL BRG	GEAR MESH	CHURN & WINDAGE	TOTAL	
IDLE	6.22	3.36	0.71	10.29	98.96
TO CLIMB	14.36	36.58	18.38	69.32	99.30*
CRUISE	14.33	30.31	16.06	60.70	99.28
DESCENT	1.90	1.33	0.05	3.27	98.99
APPROACH	12.76	21.79	10.46	45.01	99.26
REVERSE	15.82	20.99	12.91	49.72	99.19
IDLE	6.22	3.36	0.71	10.29	98.96
*SPEC 99.20%					

(ENGLISH UNITS)

CONDITION	POWER LOSS - HP				OVERALL EFFICIENCY %
	SPHERICAL BRG	GEAR MESH	CHURN & WINDAGE	TOTAL	
IDLE	8.34	4.51	0.947	13.80	98.96
TO CLIMB	19.26	49.05	24.65	92.96	99.30*
CRUISE	19.22	40.64	21.54	81.40	99.28
DESCENT	17.85	33.81	18.09	69.75	99.24
APPROACH	2.55	1.78	0.063	4.39	98.99
REVERSE	17.11	29.22	14.03	60.36	99.26
IDLE	21.21	28.15	17.31	66.67	99.19
IDLE	8.34	4.51	0.947	13.80	98.96
*SPEC 99.20%					

Total heat rejection for the flight duty cycle, delta rise in bulk oil temperature, and the temperature of the bulk oil resulting with oil flows and inlet supply temperatures shown in Table 3-9 are presented in Table 3-11.

Table 3-12 tabulates the AGMA scoring index and Table 3-13 tabulates the Curtiss-Wright scoring index for each flight duty cycle operating condition. The two approaches to scoring index calculation and evaluation were discussed in Section 2.2. Based on Curtiss-Wright experience, the maximum scoring index (AGMA 300°F, C-W 322°F) shown for the cruise part of the flight cycle is acceptable.

The Curtiss-Wright approach to the controlled deflection of the gear components under load to insure uniform loading across the face width of all mating gears discussed in Section 2.2 is carried into the UTW reduction gear detailed design. Gear and support section moduli were selected that provide relatively close gear and tooth deflection compatibility at each gear mesh. The calculated deflections are discussed in detail in Section 3.3.

Calculated UTW gear tooth load line operating positions relative to the star gear pitch line for the ring-to-star and sun-to-star meshes are shown in Figure 3-7. The displacements are the summation of deflections resulting from the operating centrifugal forces, gear tooth radial separating forces and tangential gear tooth loads. The difference in displacements over the length of the teeth results in slopes of the load line relative to the axis of the gear of 0.001080 and 0.001066 for the ring and sun gear meshes, respectively. Since the star gear is supported by a spherical bearing it is free to seek a balanced moment load position, a rotation of 0.015 mm (0.00062 inches) relative to the plane of the inner race measured at the star gear pitch line. The star gear carrier support trunnion deflects under load in the direction that improves the alignment between the star gear and the bearing inner race. Taking the trunnion deflection into consideration the star gear operating axis and the fixed carrier support trunnion axis at 100% power and 100% speed coincide within 0.00879 mm (0.000346 inches), the difference between the support deflected position and the gear tooth position shown in Figure 3-8. This very small amount of misalignment between the planes of the star gear and the star gear bearing inner race is readily accommodated by the spherical roller bearing.

TABLE 3-11
 CLASS B (UTW) REDUCTION GEAR
 HEAT REJECTION

FLIGHT CYCLE
 (SI UNITS)

CONDITION	TOTAL LOSS kW	DELTA RISE IN BULK OIL TEMP. °K	OIL IN TEMP. °K	BULK OIL TEMP. °K
IDLE	10.28	4.92	363	368
TO	69.24	25.22	366	391
CLIMB	60.63	22.17	369	391
CRUISE	52.01	19.38	383	403
DESCENT	3.27	1.57	403	405
APPROACH	44.99	17.10	370	387
REVERSE	49.70	18.43	364	382
IDLE	10.28	4.92	363	368

(ENGLISH UNITS)

CONDITION	TOTAL LOSS BTU/MIN	DELTA RISE IN BULK OIL TEMP °F	OIL IN TEMP °F	BULK OIL TEMP °F
IDLE	585	8.85	194	203
TO	3940	45.39	200	245
CLIMB	3450	39.90	205	245
CRUISE	2960	34.89	230	265
DESCENT	186	2.82	266	269
APPROACH	2560	30.78	207	238
REVERSE	2828	33.18	195	228
IDLE	585	8.85	194	203

TABLE 3-12

CLASS B (UTW) REDUCTION GEAR

AGMA SCORING INDEX

FLIGHT CYCLE

CONDITION	OIL IN TEMP °F	AGMA ΔT °F	AGMA SCORING INDEX °F
IDLE	194	18.27	212
TO	200	92.84	293
CLIMB	205	81.86	287
CRUISE	230	69.71	300
DESCENT	266	9.30	275
APPROACH	207	64.63	272
REVERSE	195	63.74	259
IDLE	194	18.27	212

TABLE 3-13

CLASS B (UTW) REDUCTION GEAR

CURTISS-WRIGHT SCORING INDEX

FLIGHT CYCLE

CONDITION	OIL IN TEMP °F	C-W SCORING INDEX - °F	
		RING-STAR MESH	SUN-STAR MESH
IDLE	194	204	217
TO	200	252	322
CLIMB	205	250	312
CRUISE	230	270	322
DESCENT	266	272	280
APPROACH	207	243	290
REVERSE	195	229	274
IDLE	194	204	217

CLASS B (UTW) REDUCTION GEAR
STAR GEAR DEFLECTION

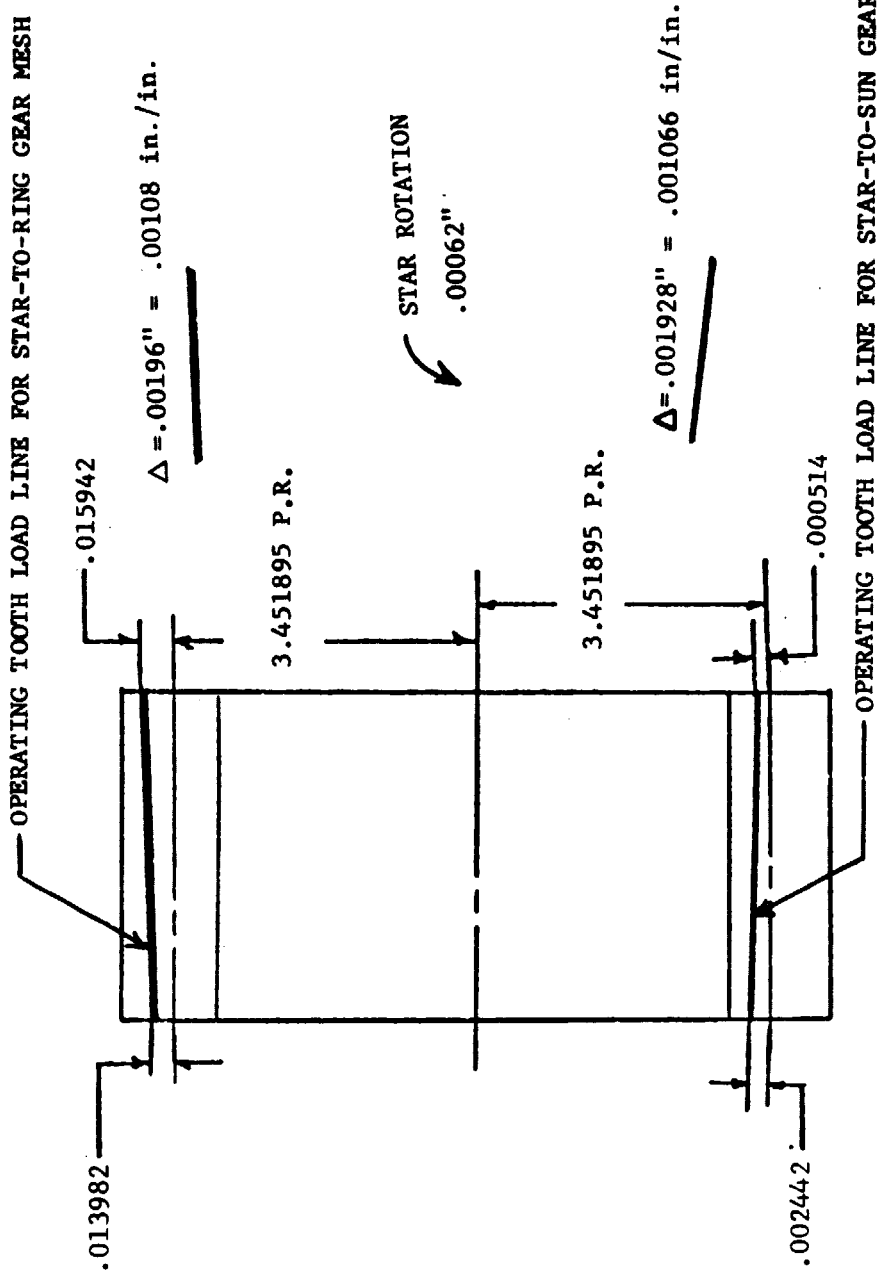
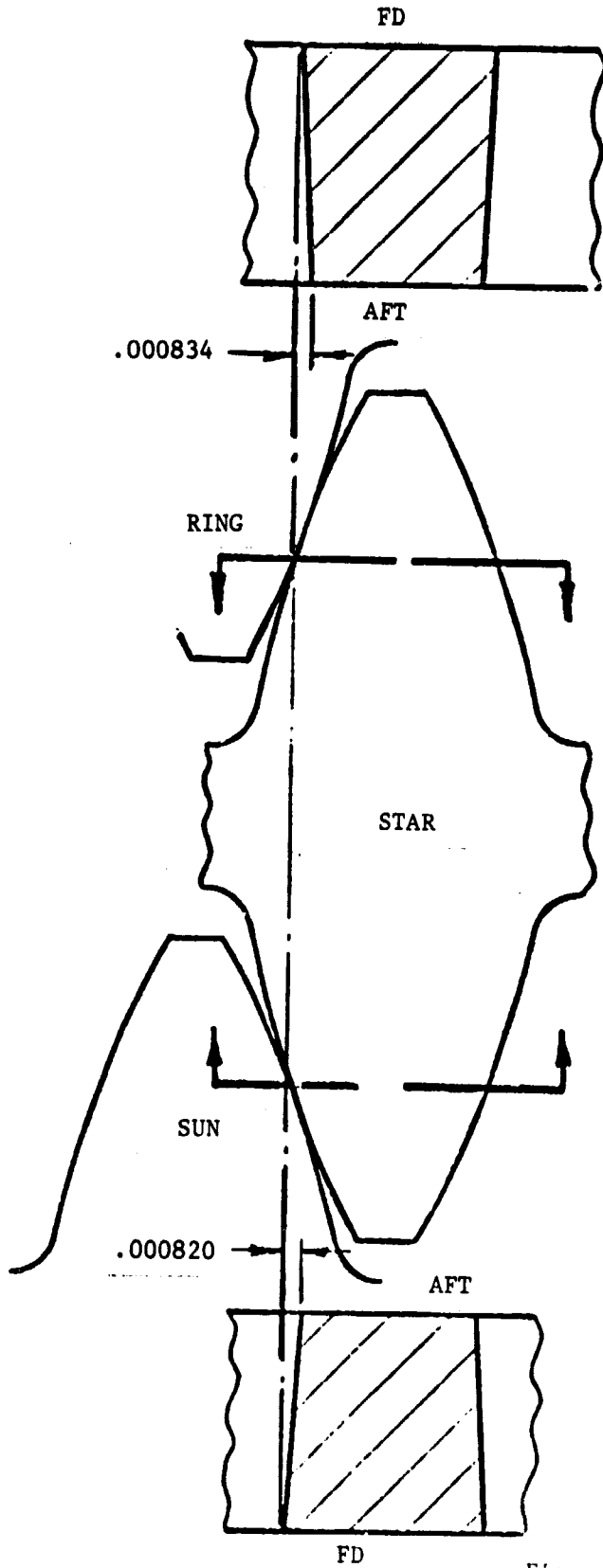

Figure 3-7

ORIGINAL PAGE IS
OF POOR QUALITY



CLASS B (UTW) REDUCTION GEAR
CONTROLLED GEAR DEFLECTIONS

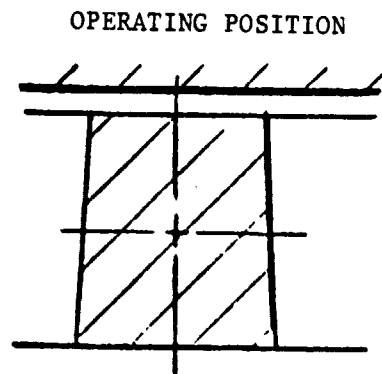
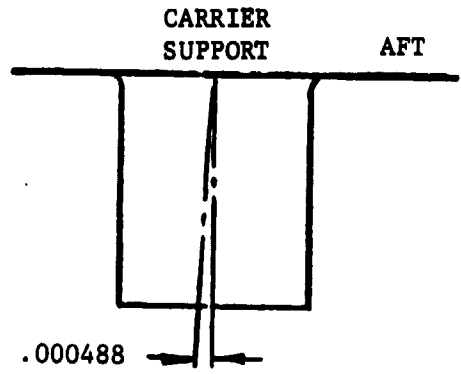

Figure 3-8

Table 3-14 tabulates the summary of the weight analysis. The calculated UTW unit installed weight as supplied by Curtiss-Wright is 92.63 kg (204.23 pounds). The detailed weight breakdown by part is given in Appendix B.

Table 3-15 tabulates weight reduction items to be considered for a production type reduction gear and these features would save a calculated 6.50 kg (14.36 pounds) and result in a future weight of 86.13 kg (189.87 pounds) for the UTW gear assembly. Further reduction in weight is possible with additional development effort directed toward a specific operating requirement.

3.2 Stress Analysis

AGMA gear stresses are presented in the preceding discussion and data. Additional stress analyses and evaluations for the gears, carrier support and flexible coupling were performed and are discussed in detail in this section of the report.

3.2.1 Gear Tooth Bending Stress

Maximum gear tooth stresses for 100 and 140% design torque are plotted on a Goodman diagram in Figure 3-9 for the sun and star gears, and Figure 3-10 for the ring gear. Three allowable curves are shown; the AGMA, Curtiss-Wright Experience, and the Minimum Material Properties. The Curtiss-Wright Experience curve represents the allowable design data that has been used at Curtiss-Wright for over three decades in the design of aircraft planetary reduction gear sets that have experienced years of satisfactory operation.

The design points fall within the AGMA allowables. For the 140% torque condition, which may be run during the experimental engine test stand operation, the star gear stress falls within the C-W experience range and is not expected to present any difficulties. Sun and ring gear stresses fall within the conservative AGMA allowables.

3.2.2 Backing Stresses

Sun Gear - Major loads on the sun gear come from the six star gears and centrifugal forces. The star gear mesh results in discrete radial and tangential forces, as well as torque loads, on the sun gear. Resulting sun gear backing

TABLE 3-14
 CLASS B (UTW) REDUCTION GEAR
 WEIGHT SUMMARY

	BASIC MATERIAL	KILOGRAMS	POUNDS
SUN GEAR ASSEMBLY	STEEL	10.34	22.79
RING GEAR	STEEL	13.56	29.90
STAR NUTS	STEEL	1.74	3.83
CARRIER SUPPORT	STEEL	22.17	48.88
STARS	STEEL	41.39	91.25
STARWASHER	STEEL	.13	.29
MANIFOLD	ALUMINUM	1.54	3.40
SPRAY BARS	STEEL	.21	.47
MISCELLANEOUS HARDWARE	-	1.55	3.42
TOTAL		92.63	204.23

TABLE 3-15
 CLASS B (UTW) REDUCTION GEAR
 FLIGHT UNIT WEIGHT REDUCTION

<p>(1) Integrate star gear carrier support and G.E. reduction gear support from fan frame to eliminate interface flange, bolts and nuts.</p> <p>(2) Make carrier support of titanium.</p> <p>Resulting system weight reduction:</p>		
	kg	lbs
FLANGE	1.27	2.81
BOLTS AND NUTS	.57	1.26
CARRIER SUPPORT MATERIAL	4.66	10.29
TOTAL	6.50	14.36

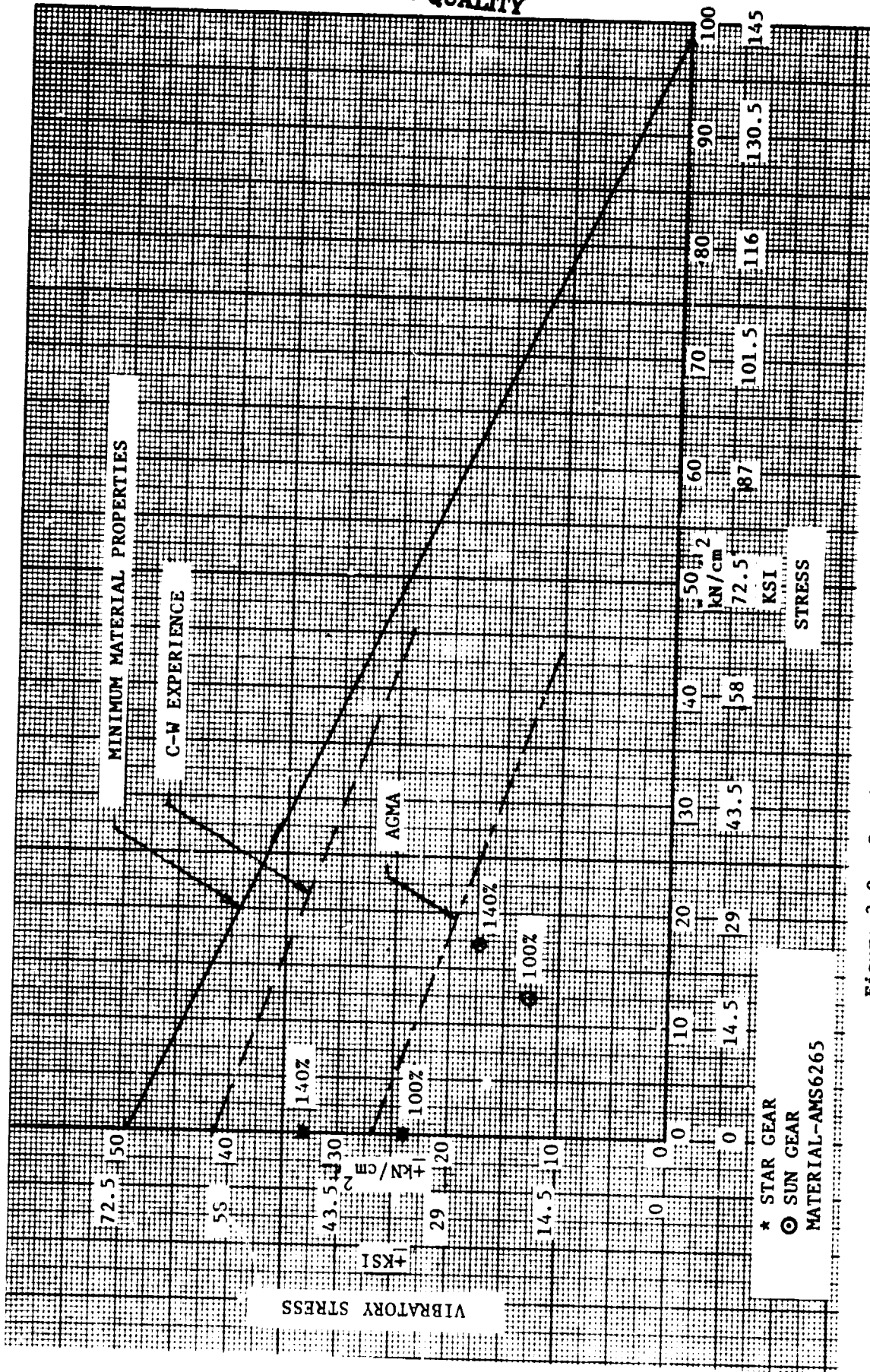

Figure 3-9. Sun And Star Gear Tooth Bending Stress
For 100% And 140% Torque, Class B (UTW)
Reduction Gear

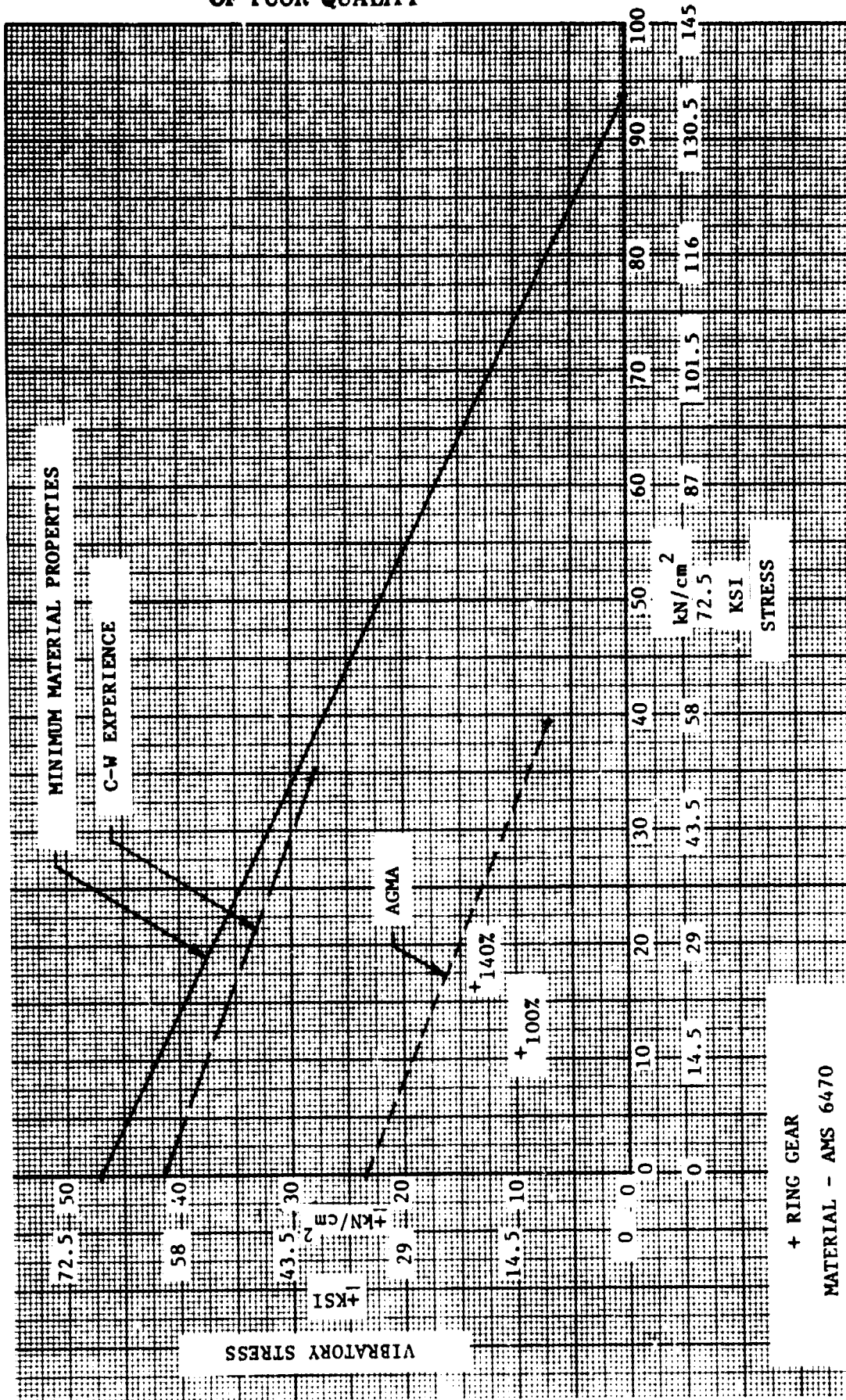

Figure 3-10. Ring Gear Tooth Bending Stress For 100% And 140% Torque
Class B (UTW) Reduction Gear

stresses are shown in Table 3-16. Radial load at each mesh of the gear will cause bending stresses in the ring, compression in the outer surface around the point of load application (greatest in tooth fillets) and tension in an area between loads. Tangential load on the gear tooth will result in a bending moment in the backing ring. The moment will cause tensile stress in the surface at the base of the tooth on the load application side and compressive stress on the opposite side. The moment is calculated by placing the tangential load (divided by the contact ratio) at the tip of the tooth.

Since the sun gear spline is not axially in the plane of the gear teeth, a toroidal moment is set up at each gear mesh. Table 3-16 shows the various stress values for the areas of high stress shown in Figure 3-11. The "front" location in Table 3-16 is identified as "I" in Figure 3-12 and the "back" location is identified as "II". Principal stresses are first calculated including the effect of any shear stresses and then the equivalent stress is calculated.

All parts have been analyzed using the criterion of failure by yielding called "Maximum Energy of Distortion Theory", also called "R. von Mises Criterion" which is discussed in Appendix E. Maximum and minimum values of equivalent stress are used to calculate the steady and vibratory components that are plotted on a Goodman diagram. Figure 3-13 shows the vibratory stresses for the sun gear without any stress concentration factors. Vibratory stresses would have to be multiplied by factors of 6 and larger before the allowable curve would be reached. Since the stress concentration factors for the gear are much lower than 6 the backing stresses in the sun gear are acceptable.

Stresses at points (5) and (6), Figure 3-11, would have a vibratory component equal to 2.2 times the steady torque before the minimum allowable material properties would be reached.

Table 3-17 shows the backing stresses for the sun gear at 100% speed and 140% design torque. Centrifugal stresses are the same as those shown on Table 3-16 but all other stresses are increased by 40%. The stresses are combined and the range of equivalent stress is plotted as steady and vibratory stress on

TABLE 3-16a
 CLASS B (UTW) REDUCTION GEAR
 SUN GEAR BACKING STRESSES (N/cm²) (SI UNITS)
 100% SPEED (811 RAD/S) 100% TORQUE (1234 N-m)

Stress Area (Fig.3-11)	Load Type	Circumferential Stress			Longitudinal	Shear	Equivalent
		At Mesh		Between Meshes			
		Front	Back				
1	Rad	- 5,066	- 5,066	+ 1,067	-	-	+ 6,729 ± 5,361
	Tang	+ 4,589	- 4,589	-	-	-	
	Centri	+ 9,028	+ 9,028	+ 9,028	-	-	
	T.M.	+ 1,995	+ 1,995	+ 1,995	-	-	
	Total	+10,546	+ 1,368	+12,091	-	-	
2	Rad	+ 3,888	+ 3,888	- 3,472	-	-	+13,081 ± 6,163
	Tang	- 5,283	+ 5,283	-	-	+ 1,517	
	Centri	+ 9,028	+ 9,028	+ 9,028	-	-	
	T.M.	+ 843	+ 843	+ 843	-	-	
	Total	+ 8,476	+19,063	+ 6,399	-	+ 1,517	
3	Rad	+ 3,888	+ 3,888	- 3,472	-	-	+19,201 ± 4,279
	Tang	- 5,283	+ 5,283	-	-	+ 7,445	
	Centri	+ 9,028	+ 9,028	+ 9,028	- 3,935	-	
	T.M.	- 843	- 843	- 843	-	-	
	Total	+ 6,789	+17,356	+ 4,710	- 3,935	+ 7,445	
4	Rad	- 3,888	- 3,888	+ 3,472	-	-	+15,073 ± 1,409
	Tang	+ 5,283	- 5,283	-	-	+ 7,445	
	Centri	+ 9,028	+ 9,028	+ 9,028	+ 3,935	-	
	T.M.	- 843	- 843	- 843	-	-	
	Total	+ 9,580	- 987	+11,657	+ 3,935	+ 7,445	
5	Total (Tang)	4,414	4,414	+ 4,414	+ 3,926	10,290	18,308
6	Total (Tang)	+ 2,437	+ 2,437	+ 2,437	- 2,842	10,290	18,401

Abbreviations:
 Radial - Rad Centrifugal - Centri
 Tangential - Tang Toroidal Moment - T.M.

TABLE 3-16b

CLASS B (UTW) REDUCTION GEAR

SUN GEAR BACKING STRESSES (PSI) (ENGLISH UNITS)

100% SPEED (7747 RPM) 100% TORQUE (107,392 IN-LB)

Stress Area (Fig. 3-11) Load		Circumferential Stress			Longitudinal	Shear	Equivalent
		At Mesh		Between Meshes			
		Front	Back				
1	Rad	- 7,348	- 7,348	+ 1,548	-	-	
	Tang	+ 6,656	- 6,656	-	-	-	+ 9,760
	Centri	+13,094	+13,094	+13,094	-	-	<u>+ 7,776</u>
	T.M.	+ 2,894	+ 2,894	+ 2,894	-	-	
	Total	+15,296	+ 1,984	+17,536	-	-	
2	Rad	+ 5,639	+ 5,639	- 5,036	-	-	
	Tang	- 7,663	+ 7,663	-	-	+ 2,200	
	Centri	+13,094	+13,094	+13,094	-	-	+18,972
	T.M.	+ 1,223	+ 1,223	+ 1,223	-	-	<u>+ 8,939</u>
	Total	+12,293	+27,649	+ 9,281	-	+ 2,200	
3	Rad	+ 5,639	+ 5,639	- 5,036	-	-	
	Tang	- 7,663	+ 7,663	-	-	+10,798	+27,849
	Centri	+13,094	+13,094	+13,094	- 5,707	-	<u>+ 6,206</u>
	T.M.	- 1,223	- 1,223	- 1,223	-	-	
	Total	+ 9,847	+25,173	+ 6,832	- 5,707	+10,798	
4	Rad	- 5,639	- 5,639	+ 5,036	-	-	
	Tang	+ 7,663	- 7,663	-	-	+10,798	+21,862
	Centri	+13,094	+13,094	+13,094	+ 5,707	-	<u>+ 2,043</u>
	T.M.	- 1,223	- 1,223	- 1,223	-	-	
	Total	+13,895	- 1,431	+16,907	+ 5,707	+10,798	
5	Total (Tang)	6,402	6,402	+ 6,402	+ 5,694	14,924	26,554
6	Total (Tang)	+ 3,535	+ 3,535	+ 3,535	- 4,122	14,924	26,688

Abbreviations:

Radial - Rad
Tangential - Tang

Centrifugal - Centri
Toroidal Moment - T.M.

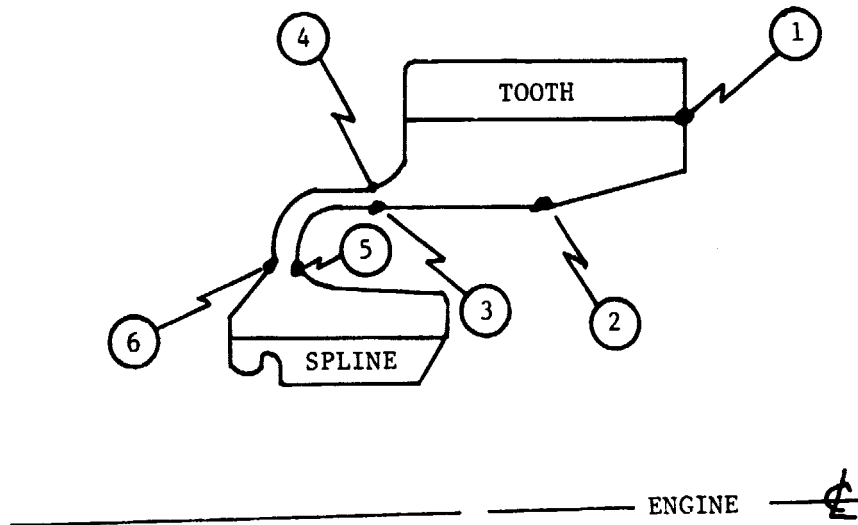

① NUMBERS IDENTIFY STRESS ANALYSIS AREAS, TABLES 3-16 AND 3-17.

REFERENCE 100% SPEED AND LOAD DATA

DATA ITEM	DATA ITEM MAGNITUDE	
	ENGLISH UNITS	SI UNITS
100% SPEED	7,747 RPM	811 RAD/S
100% TORQUE	107,392 IN./LB	12,134 N-M
TANGENTIAL LOAD	3,798 LBS/STAR	16,894 N/STAR
RADIAL LOAD	1,458 LBS/STAR	6,486 N/STAR

Figure 3-11. Sun Gear High Stress Areas (Identification For Tables 3-16 & 3-17) Class B (UTW) Reduction Gear.

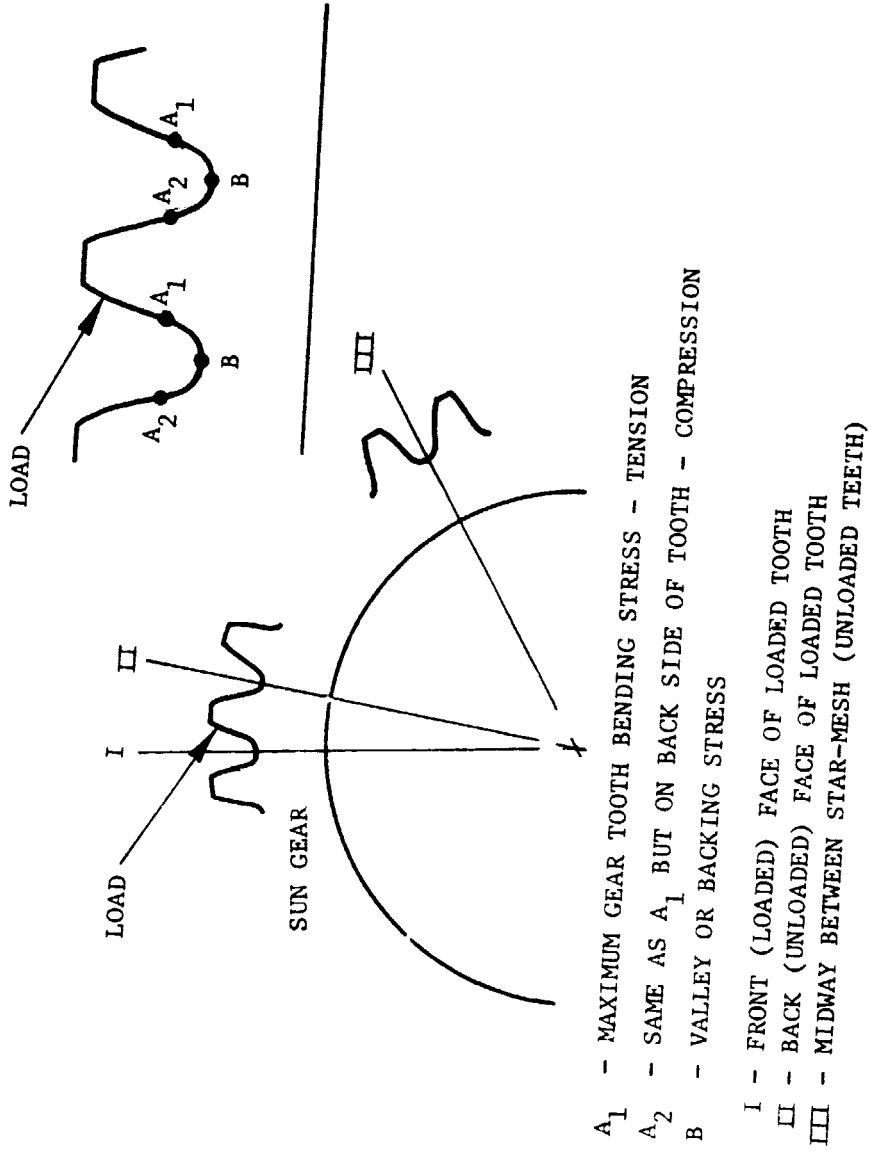
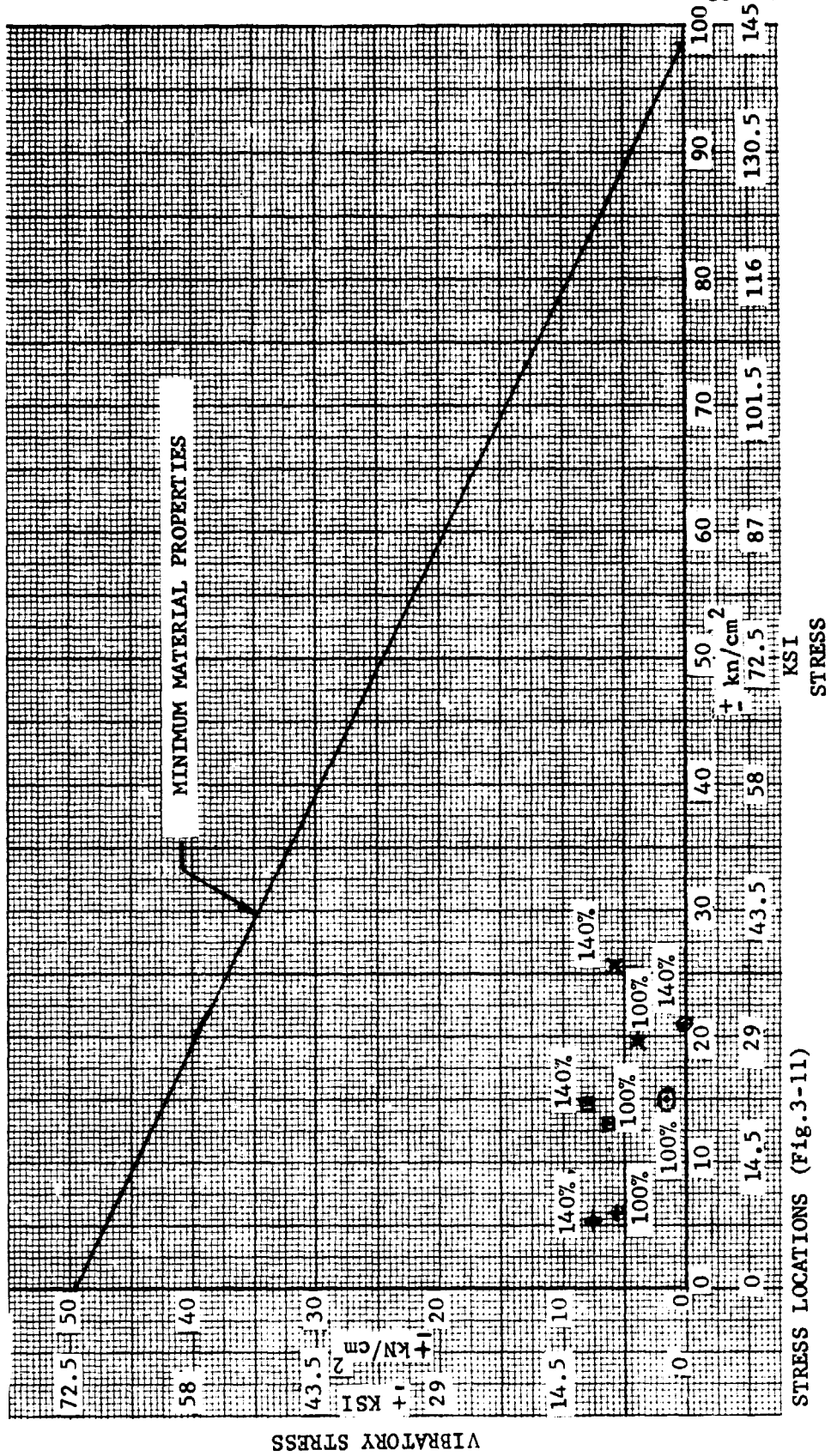

Figure 3.12 Gear Tooth Loading for "Combined" Stress Analysis



- 1 +
- 2 □
- 3 X
- 4 ⊙

MATERIAL - AMS 6265

Figure 3-13. Sun Gear Backing Stress For 100% And 140% Torque
(No Stress Concentration Factors) Class B (UTW) Reduction Gear.

TABLE 3-17a

CLASS B (UTW) REDUCTION GEAR
 SUN GEAR BACKING STRESSES (N/cm²) (SI UNITS)
 100% SPEED (811 RAD/S) 140% TORQUE (16,987 N-m)

Stress Area (Fig.3-11) Load		Circumferential Stress			Longitudinal	Shear	Equivalent
		At Star		Between Stars			
		Front	Back				
1	Rad	- 7,093	- 7,093	+ 1,494			
	Tang	+ 6,425	- 6,425	-			
	Centri	+ 9,028	+ 9,028	+ 9,028			+ 5,812
	T.M.	+ 2,794	+ 2,794	+ 2,794			<u>+ 7,508</u>
	Total	+11,154	- 1,695	+13,320			
2	Rad	+ 5,443	+ 5,443	- 4,861	-	-	
	Tang	- 7,397	+ 7,397	-	-	+ 2,124	
	Centri	+ 9,028	+ 9,028	+ 9,028	-	-	+14,915
	T.M.	+ 1,180	+ 1,180	+ 1,180	-	-	<u>+ 8,425</u>
	Total	+ 8,255	+23,048	+ 5,346		+ 2,124	
3	Rad	+ 6,707	+ 6,708	- 3,400			
	Tang	- 7,397	+ 7,397	-	-	+10,424	
	Centri	+ 9,028	+ 9,028	- 9,028	- 5,509	-	+25,493
	T.M.	- 1,180	- 1,180	- 1,180			<u>+ 5,512</u>
	Total	+ 7,159	+21,952	+ 4,447	- 5,509	+19,424	
4	Rad	- 6,708	- 6,708	+ 3,400	-	-	
	Tang	+ 7,397	- 7,397	-	-	-10,424	+20,626
	Centri	+ 9,028	+ 9,028	+ 9,028	-	-	
	T.M.	- 1,180	- 1,180	- 1,180			
	Total	+ 8,536	- 6,257	+11,248	+ 5,509	+10,424	
5	Tang	+ 6,180	+ 6,180	+ 6,180	+ 5,497	+14,406	25,633
6	Tang	+ 3,412	- 3,412	+ 3,412	- 3,378	+14,406	25,761
Abbreviations: Radial - Rad Centrifugal - Centri Tangential - Tang Toroidal - T.M.							

TABLE 3-17b

CLASS B (UTW) REDUCTION GEAR

SUN GEAR BACKING STRESSES (PSI) (ENGLISH UNITS)

100% SPEED (7747 RPM) 140% TORQUE (150,349 IN-LB)

Stress Area (Fig.3-11) Load		Circumferential Stress			Longitudinal	Shear	Equivalent
		At Star		Between Stars			
		Front	Back				
1	Rad	-10,287	-10,287	+ 2,167			
	Tang	+ 9,318	- 9,318	-			
	Centri	+13,094	+13,094	+13,094			+ 8,430
	T.M.	+ 4,052	+ 4,052	+ 4,052			<u>+10,889</u>
	Total	+16,177	- 2,459	+19,319			
2	Rad	+ 7,895	+ 7,895	- 7,050	-	-	
	Tang	-10,728	+10,728	-	-	+ 3,080	
	Centri	+13,094	+13,094	+13,094	-	-	+21,633
	T.M.	+ 1,712	+ 1,712	+ 1,712	-	-	<u>+12,220</u>
	Total	+11,973	+33,429	+ 7,756		+ 3,080	
3	Rad	+ 9,729	+ 9,729	- 4,932	-	-	
	Tang	-10,728	+10,728	-	-	+15,119	
	Centri	+13,094	+13,094	+13,094	- 7,990	-	+36,974
	T.M.	- 1,712	- 1,712	- 1,712			<u>± 7,944</u>
	Total	+10,383	+31,839	+ 6,450	- 7,990	+15,119	
4	Rad	- 9,729	- 9,729	+ 4,932	-	-	
	Tang	+10,728	-10,728	-	-	+15,119	+29,915
	Centri	+13,094	+13,094	+13,094	+ 7,990	-	<u>± 159</u>
	T.M.	- 1,712	- 1,712	- 1,712		-	
	Total	+12,381	- 9,075	+16,314	+ 7,990	+15,119	
5	Tang	+ 8,963	+ 8,963	+ 8,963	+ 7,972	+20,894	37,177
6	Tang	+ 4,949	+ 4,949	+ 4,949	- 5,770	+20,894	37,363
Abbreviations:							
Radial - Rad				Centrifugal - Centri			
Tangential - Tang				Toroidal Moment - T.M.			

Figure 3-13. Backing stresses in the sun gear will present no problem when the reduction gear is operated at 140% design torque at 100% speed.

Vibratory margin, that is, the allowable vibratory stress divided by the calculated vibratory stress, is over 5.0 and is much larger than any stress concentration factor that might exist. For point (5) the vibratory torque would have to be over twice the design torque to reach the allowable limit.

Ring Gear - Major loads on the ring gear are the radial loads, the tangential loads and the centrifugal forces. Stresses were calculated at specific locations as noted in Figure 3-14 for each of the major loads. The bending stresses in the ring gear due to the radial loads were believed to be conservatively calculated by assuming no restraint from the adjacent shell and spline of the General Electric furnished fan drive components. Stresses were calculated for the ring gear under the influence of centrifugal forces and radial loads (by use of a well-proven shell computer program) and found to be small, less than 4136 N/cm^2 (6000 psi) in the meridial direction. Tables 3-18 and 3-19 show the breakdown of individual stresses for 100% design speed and 100% and 140% design torque, respectively. The stresses are converted to equivalent stresses and the resulting steady and vibratory components are plotted on the Goodman diagram shown on Figure 3-15. Backing stresses are higher on the ring gear than the sun gear primarily due to the stresses caused by the radial loads. At points (1) and (3) where stress concentration factors would exist, the vibratory margin is over 3.3 for the design condition and 2.4 for the 140% torque operating point. Since the basic analysis is believed to be conservative, these margins are considered satisfactory.

Calculated shear stress in the cylindrical section between the ring gear and spline is 2710 N/cm^2 (3932 psi). Application of any reasonable stress concentration factor for the 9.53 mm (.375 inch) diameter radial holes (polished edges) in this section still results in a relatively low stress value in this area.

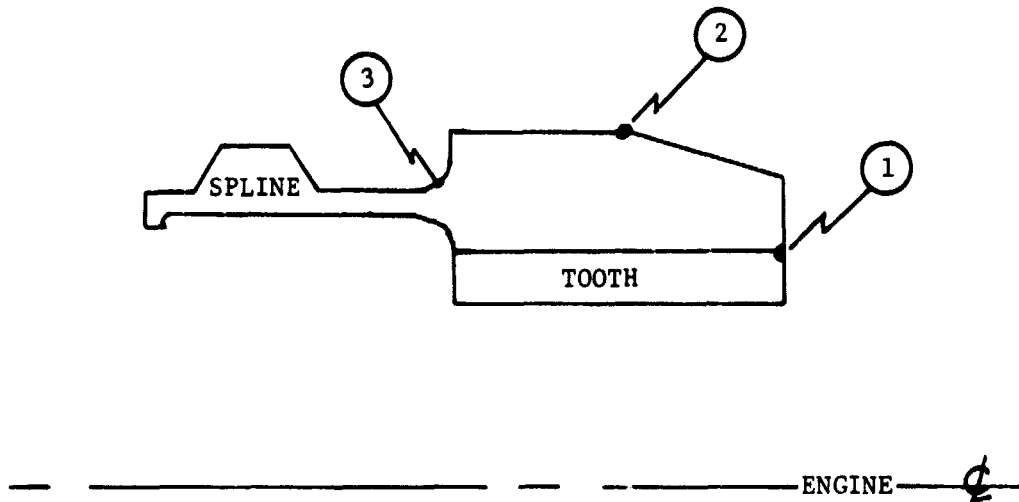

① NUMBERS IDENTIFY STRESS ANALYSIS AREAS, TABLES 3-18 AND 3-19

REFERENCE 100% SPEED AND LOAD DATA

DATA ITEM	DATA ITEM MAGNITUDE	
	ENGLISH UNITS	SI UNITS
100% SPEED	3,143 RPM	329 RAD/S
100% TORQUE	264,704 IN./LB	29,908 N-M
TANGENTIAL LOAD	3,798 LBS/STAR	16,894 N/STAR
RADIAL LOAD	1,458 LBS/STAR	6,486 N/STAR

Figure 3-14. Ring Gear High Stress Areas (Identification For Tables 3-18 & 3-19) Class B (UTW) Reduction Gear.

TABLE 3-18a
 CLASS B (UTW) REDUCTION GEAR
 RING GEAR BACKING STRESSES (N/cm²) (SI UNITS)
 100% SPEED (329 RAD/S); 100% TORQUE (29908 N-M)

Point	Load	Circumferential Stress			Longitudinal	Shear	Equivalent N/cm ²
		At Star		Between Stars N/cm ²			
		Front N/cm ²	Back N/cm ²				
1	Rad	-12,857	-12,857	+ 8,144			
	Tang	+ 4,941	- 4,941	-			
	Centri	+19,670	+10,670	+10,670			
	T.M.	+ 2,355	+ 2,355	+ 2,355			
	Total	+ 5,108	- 4,773	+21,169			+ 8,198 <u>+12,971</u>
2	Rad	+17,010	+17,010	- 6,988			
	Tang	- 5,725	+ 5,725				
	Centri	+10,670	+10,670	+10,670			
	T.M.	+ 598	+ 598	+ 598			
	Total	+22,553	+34,004	+ 4,270			+19,137 <u>+14,867</u>
3	Rad	+ 6,769	+ 6,769	- 5,057	+ 276	-	
	Tang	- 1,995	+ 1,995	-	-	+2,503	
	Centri	+10,670	+10,670	+10,670		-	
	T.M.	- 2,282	- 2,282	- 2,282		-	
	Total	+13,162	+17,152	+ 3,330	+ 276	+2,503	+10,761 <u>+ 6,389</u>
Abbreviations:							
Radial - Rad				Centrifugal - Centri			
Tangential - Tang				Toroidal Moment - T.M.			

TABLE 3-18b
 CLASS B (UTW) REDUCTION GEAR
 RING GEAR BACKING STRESSES (PSI)(ENGLISH UNITS)
 100% SPEED (3143 RPM); 100% TORQUE (264,704 IN-LB)

Stress Area (Fig.3-14) Point	Load	Circumferential Stress			Longitudinal	Shear	Equivalent
		At Star		Between Stars			
		Front	Back				
1	Rad	-18,648	-18,648	+11,812			
	Tang	+ 7,166	- 7,166	-			
	Centri	+15,475	+15,475	+15,475			
	T.M.	+ 3,416	+ 3,416	\$ 3,416			
	Total	+ 7,409	- 6,923	+30,703			+11,890 <u>+18,813</u>
2	Rad	+24,671	+24,671	-10,150			
	Tang	- 8,304	+ 8,304				
	Centri	+15,475	+15,475	+15,475			
	T.M.	+ 868	+ 868	+ 868			
	Total	+32,710	+49,318	+ 6,193			+27,756 <u>+21,563</u>
3	Rad	+ 9,818	+ 9,818	- 7,335	+ 401	-	
	Tang	- 2,893	+ 2,893	-	-	+3,631	
	Centri	+15,475	+15,475	+15,475	-	-	
	T.M.	- 3,310	- 3,310	- 3,310	-	-	
	Total	+19,090	+24,876	+ 4,830	+ 401	+3,631	+15,608 <u>+ 9,267</u>
Abbreviations:							
Radial - Rad				Centrifugal - Centri			
Tangential - Tang				Toroidal Moment - T.M.			

TABLE 3-19a

CLASS B (UTW) REDUCTION GEAR

RING GEAR BACKING STRESSES (N/cm²)(SI UNITS)
 100% SPEED (329 RAD/S); 140% TORQUE(41,871 N-MO)

Stress Area (Fig.3-14)	Load	Circumferential Stress			Longitudinal	Shear	Equivalent
		At Star		Between Stars			
		Front	Back				
1	Rad	-18,000	-18,000	+11,402			
	Tang	+ 6,917	- 6,917	-			
	Centri	+10,670	+10,670	+10,670			7,206
	T.M.	+ 3,297	+ 3,297	+ 3,297			-18,156
	Total	+ 2,883	-10,950	+25,362			
2	Rad	+23,814	+23,814	- 9,797			
	Tang	- 8,015	- 8,015	-			+22,520
	Centri	+10,670	+10,670	+10,670			
	T.M.	+ 838	+ 838	838			<u>+20,810</u>
	Total	+27,306	+43,329	+ 1,710			
3	Rad	+13,212	+13,212	+ 7,080	+ 387	-	
	Tang	- 2,792	+ 2,792	-	-	+ 3,449	
	Centri	+10,670	+10,670	+10,670	-	-	
	T.M.	- 3,195	- 3,195	- 3,195	-	-	+13,912
	Total	+17,895	+23,480	+ 394	+ 387	+ 3,449	<u>+10,072</u>
Abbreviations:							
Radial - Rad				Centrifugal - Centri			
Tangential - Tang				Toroidal Moment - T.M.			

TABLE 3-19b
CLASS B (UTW) REDUCTION GEAR

RING GEAR BACKING STRESSES (PSI)(ENGLISH UNITS)
100% SPEED (3143 RPM) 140% TORQUE (370,586 IN-LB)

Stress Area (Fig.3-14)	Load	Circumferential Stress			Longitudinal	Shear	Equivalent
		At Star		Between Stars			
		Front	Back				
1	Rad	-26,107	-26,107	+16,537			10,451 <u>+26,333</u>
	Tang	+10,032	-10,032	-			
	Centri	+15,475	+15,475	+15,475			
	T.M.	+ 4,782	+ 4,782	+ 4,782			
	Total	+ 4,182	-15,882	+36,784			
2	Rad	+34,539	+34,539	-14,210			+32,662 <u>+30,182</u>
	Tang	-11,625	+11,625	-			
	Centri	+15,475	+15,475	+15,475			
	T.M.	+ 1,215	+ 1,215	+ 1,215			
	Total	+39,604	+62,844	+ 2,480			
3	Rad	+19,163	+19,163	-10,269	+ 561	-	+20,177 <u>+14,608</u>
	Tang	- 4,050	+ 4,050	-	-	+ 5,003	
	Centri	+15,475	+15,475	+15,475	-	-	
	T.M.	- 4,634	- 4,634	- 4,634	-	-	
	Total	+25,954	+34,054	+ 572	+ 561	+ 5,003	
Abbreviations:							
Radial - Rad				Centrifugal - Centri			
Tangential - Tang				Toroidal Moment - T.M.			

ORIGINAL PAGE IS
OF POOR QUALITY

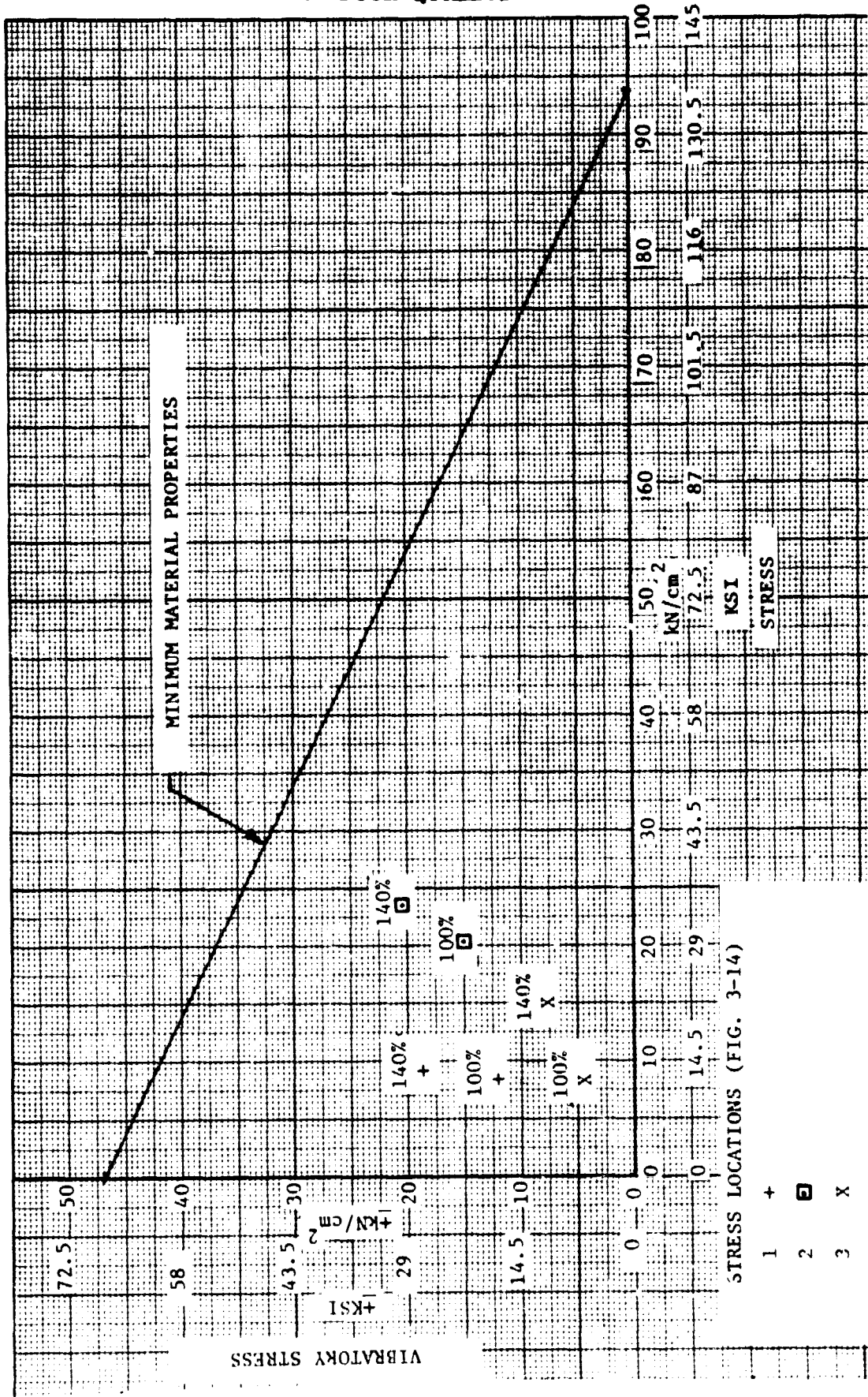

Figure 3-15. Ring Gear Backing Stress For 100% And 140% Torque Class B (UTW) Reduction Gear

MATERIAL - AMS 6740

Star Gear - Analysis of the backing stresses in the star gear was identical to that performed on the sun and ring gears with the exception that there is no toroidal moment applied. In calculating the effect of radial loads, forces are applied at two locations 180° apart. The bearing radial clearance is taken into consideration since it limits the amount of radial deflection caused by the gear tooth separating forces.

Table 3-20 shows the detailed star gear backing stresses for both the 100% and 140% design torque operation for the specific locations as noted in Figure 16. The Goodman diagram for the gear material, AMS 6265, is shown on Figure 3-17 for the two points at which the stresses are calculated. The lowest vibratory margins are over 7.0 for both the design torque condition and the 140% torque, a stress situation which is satisfactory.

3.2.3 "Combined" Stress

Curtiss-Wright practice has been to analyze the gear tooth bending stress according to AGMA methods and compare it to C-W allowables. The gear backing stresses are calculated in the manner described above and plotted on Goodman diagrams for minimum material properties. If both stress values show satisfactory margins when compared to their respective allowables, the gear component is considered satisfactory.

In response to a request from General Electric to "combine" the effect of the gear tooth bending and gear backing stresses, several methods were reviewed. The method selected is a conservative technique since it actually adds the two effects even though the locations of maximum stresses are not coincident. It should be noted that the following discussion of combined stress is not a rigorous calculation of the actual stresses that exist but is a conservative estimate of them.

Sun Gear - In order to combine the tooth bending stress and the backing stress a more detailed view of stresses in the gear must be taken. Figure 3-12 shows the gear load acting on a particular tooth of the sun gear. Locations identified as "A" are points of maximum tooth bending stress. The subscript 1 implies tensile stresses and the subscript 2 (on the opposite side of the

C-2

TABLE 3-20a
 CLASS B (UTW) REDUCTION GEAR
 STAR GEAR BACKING STRESSES (N/cm²) (SI UNITS)
 100% SPEED 1,108 RAD/S

100% Torque 1,481 N-m					
Stress Area (Fig.3-16)	Load	At Mesh		Between Meshes	Equivalent
		Front	Back		
1	Rad.	- 3,697	- 3,697	2,110	4,888 <u>± 4,564</u>
	Tang.	+ 3,320	3,320	-	
	Centri	+ 7,341	+ 7,341	+ 7,341	
	Total	+69,637	325	9,451	
2	Rad	+ 3,564	3,564	- 2,034	9,706 <u>± 4,400</u>
	Tang	- 3,201	3,201	-	
	Centri	+ 7,341	+ 7,341	+ 7,341	
	Total	+ 7,704	+14,167	+ 5,307	
140% Torque 2,074 N-m					
1	Rad.	- 5,176	- 5,176	2,954	3,906 6,389
	Tang.	- 4,648	- 4,648	-	
	Centri.	+ 7,341	+ 7,341	+ 7,341	
	Total	+ 6,813	- 2,483	+10,295	
2	Rad.	+ 4,990	+ 4,990	- 2,848	+10,652 <u>± 6,159</u>
	Tang.	- 4,481	+ 4,480	-	
	Centri.	+ 7,341	+ 7,341	+ 7,341	
	Total	+ 7,850	+16,811	- 4,493	
Abbreviations: Radial - Rad Tangential - Tang Centrifugal - Centri					

TABLE 3-20b
 CLASS B (UTW) REDUCTION GEAR
 STAR GEAR BACKING STRESSES (PSI)(ENGLISH UNITS)
 100% SPEED (10,577 RPM)

100% Torque 13,110 In.-Lb.					
Stress Area (Fig. 3-16) Load		At Mesh		Between Meshes	Equivalent
		Front	Back		
1	Rad.	-5,362	-5,362	+3,060	+7,089 <u>+6,619</u>
	Tang.	+4,815	-4,815	-	
	Centri	+10,647	+10,647	+10,647	
	Total	+10,100	+470	+13,707	
2	Rad.	+5,169	+5,169	-2,950	+14,078 <u>+6,381</u>
	Tang	-4,642	+4,642	-	
	Centr.	+10,647	+10,647	+10,647	
	Total	+11,174	+20,458	+7,697	
140% Torque 18,354 In.-Lb.					
1	Rad.	-7,507	-7,507	+4,284	+5,665 <u>+9,266</u>
	Tang.	+6,741	-6,741	-	
	Centri.	+10,647	+10,647	+10,647	
	Total	+9,881	-3,601	+14,931	
2	Rad.	+7,237	+7,237	-4,130	+15,450 <u>+8,933</u>
	Tang.	-6,499	+6,498	-	
	Centri.	+10,647	+10,647	+10,647	
	Total	+11,385	+24,382	+6,517	
Abbreviations: Radial - Rad Tangential - Tang Centrifugal - Centri					

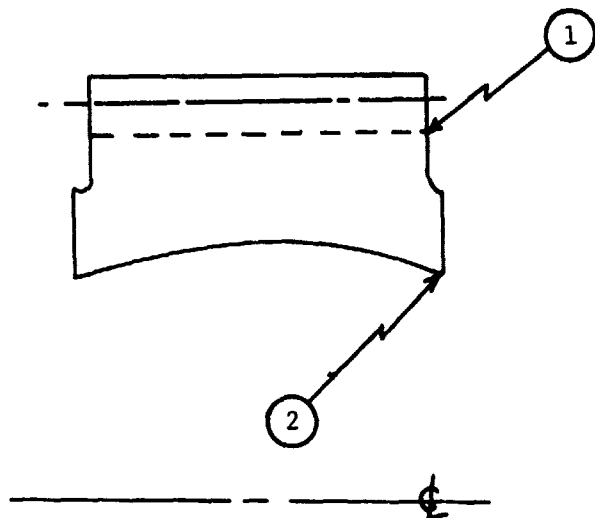

① NUMBERS IDENTIFY STRESS ANALYSIS AREAS, TABLE 3-20

REFERENCE 100% SPEED AND LOAD DATA

DATA ITEM	DATA ITEM MAGNITUDE	
	ENGLISH UNITS	SI UNITS
100% RPM	10,577 RPM	1,108 RAD/S
100% TORQUE	13,110 IN./LBS	1,481 N-M
TANGENTIAL LOAD	3,798 LBS	16,894 N
RADIAL LOAD	1,458 LBS	6,486 N

Figure 3-16. Star Gear High Stress Areas (Identification For Table 3-20)
Class B (UTW) Reduction Gear.

ORIGINAL PAGE IS
OF POOR QUALITY

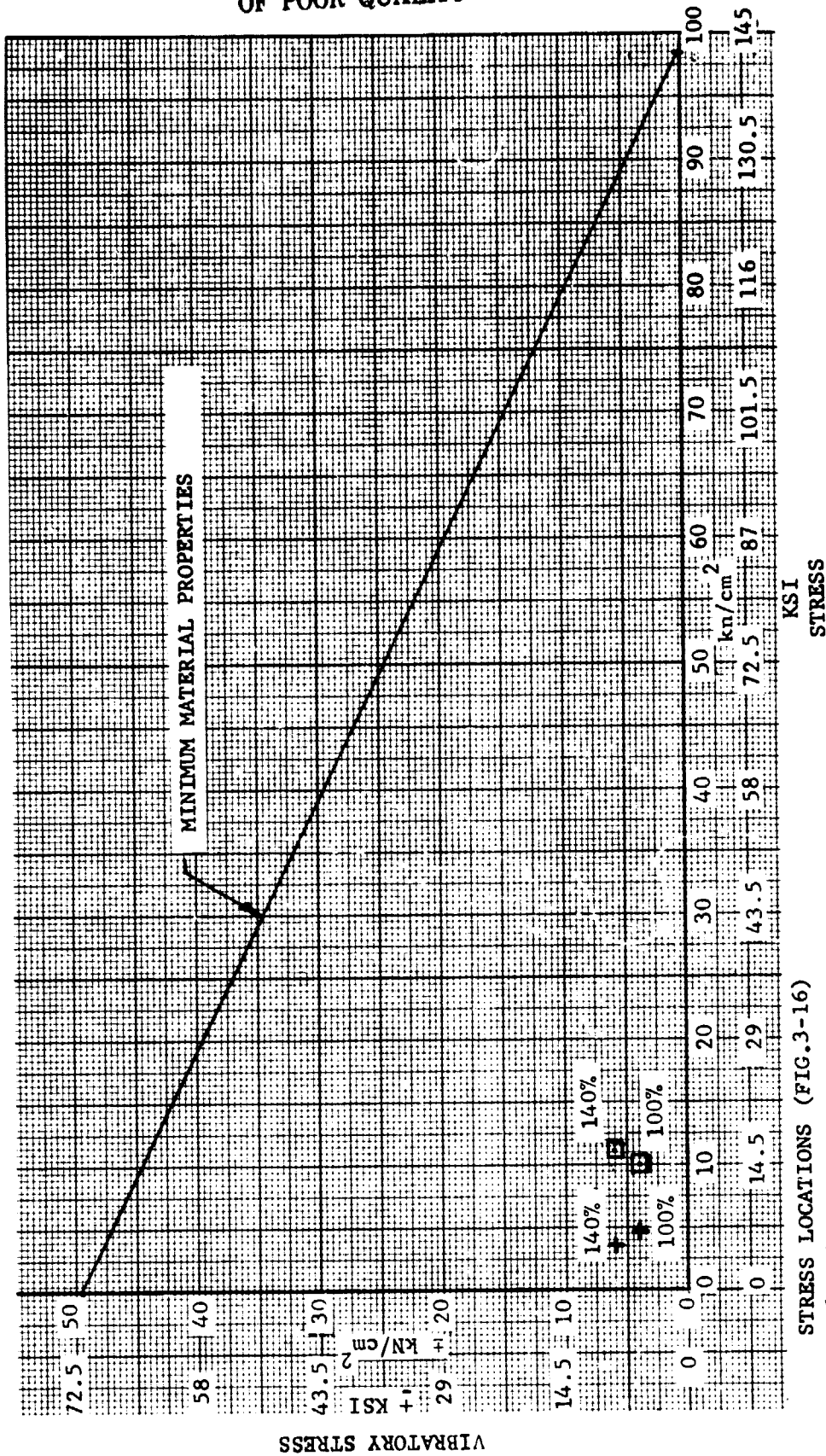

STRESS LOCATIONS (FIG.3-16)

- 1 +
- 2 □

MATERIAL - AMS 6265

Figure 3-17. Star Gear Backing Stress For 100% Speed, 100% And 140% Torque Class B (UTW) Reduction Gear.

loaded tooth) implies compressive stress. The "B" locations are backing or "valley" stresses. At a given instant of time, the notation "I" identifies the stresses in the valley (also identified as circumferential stress at mesh, front, on Table 3-16), and loaded side of the loaded tooth. The notation "II" identifies the back side of the loaded tooth and its associated valley stresses. The stresses away from the loaded tooth are identified as "III". Stress value locations shown in Table 3-21 correspond to the notations described. The gear tooth bending stress for the sun gear is $24,869 \text{ N/cm}^2$ (36,070 psi) which includes a stress concentration factor (1.91 in this case). This value is entered as a tensile stress at "I" and a compressive stress at "II". At point "II" the value of A_1 is zero because there is no gear load on that tooth at that instant of time. That is also the reason that A_2 is zero at point "I". At point "III", there is no load on any adjacent teeth and both A_1 and A_2 are zero. Valley stresses are from Table 3-16 with a stress concentration factor of 1.5 applied. The values for "B" at points "I", "II" and "III" are from the first, second and third columns of Table 3-16. It should be noted that the tangential stress is tension on the loaded side and compression on the unloaded side.

For point "I" the stress from the first column is totaled including a tensile stress contribution from the gear tangential load. The tangential load on the gear causes a compressive stress at point "II" which is added algebraically to the stresses resulting from the radial load, centrifugal force and toroidal moment. The stresses at A_1 , A_2 and B are added together for the three points of interest, I, II and III in Table 3-21. From these values a stress range is determined and finally a mean and vibratory stress is calculated and plotted on a Goodman diagram for AMS 6265 material, Figure 3-18. The "combined" stress data for the sun gear is plotted on this figure for both 100% and 140% design torque operation. With the conservative approach used to estimate the stresses, the resulting vibratory margin of 1.41 for 100% torque is very satisfactory. The margin for the 140% torque point is 1.03. The Goodman diagram was drawn for the base material and the endurance strength can be increased by 15% due to the shot peening that will be applied to the valley area. Therefore, the 140% torque operation is considered satisfactory.

TABLE 3-21a
CLASS B (UTW) REDUCTION GEAR
SUN GEAR "COMBINED" STRESS (N/cm²) (SI UNITS)
100% SPEED (811 RAD/S)
INCLUDES STRESS CONCENTRATION FACTORS

100 % TORQUE

Location (Fig.3-12)	I	II	III	Equivalent
A1	+24,869	0	0	
A2	0	-24,869	0	
B	+15,819	+ 2,052	+18,136	+ 8,936
Total	+40,689	-22,816	+18,136	+31,753

140 % TORQUE

Location (Fig.3-12)	I	II	III	Equivalent
A1	+34,817	0	0	
A2	0	-34,817	0	+ 7,094
B	+16,731	- 2,543	19,980	+44,455
Total	+51,548	-37,361	+19,980	

TABLE 3-21b
CLASS B (UTW) REDUCTION GEAR

SUN GEAR "COMBINED" STRESS (PSI) (ENGLISH UNITS)

100% SPEED (7747 RPM)

INCLUDES STRESS CONCENTRATION FACTORS

100% TORQUE

Location (Fig.3-12)	I	II	III	Equivalent
A1	+36,070	0	0	
A2	0	-36,070	0	
B	+22,944	+ 2,976	+26,304	+12,960
Total	+59,014	-33,094	+26,304	+46,054

140% TORQUE

Location (Fig.3-12)	I	II	III	Equivalent
A1	+50,498	0	0	
A2	0	-50,498	0	+10,289
B	+24,266	- 3,689	28,979	+64,476
Total	+74,764	-54,187	+28,979	

ORIGINAL PAGE IS
OF POOR QUALITY

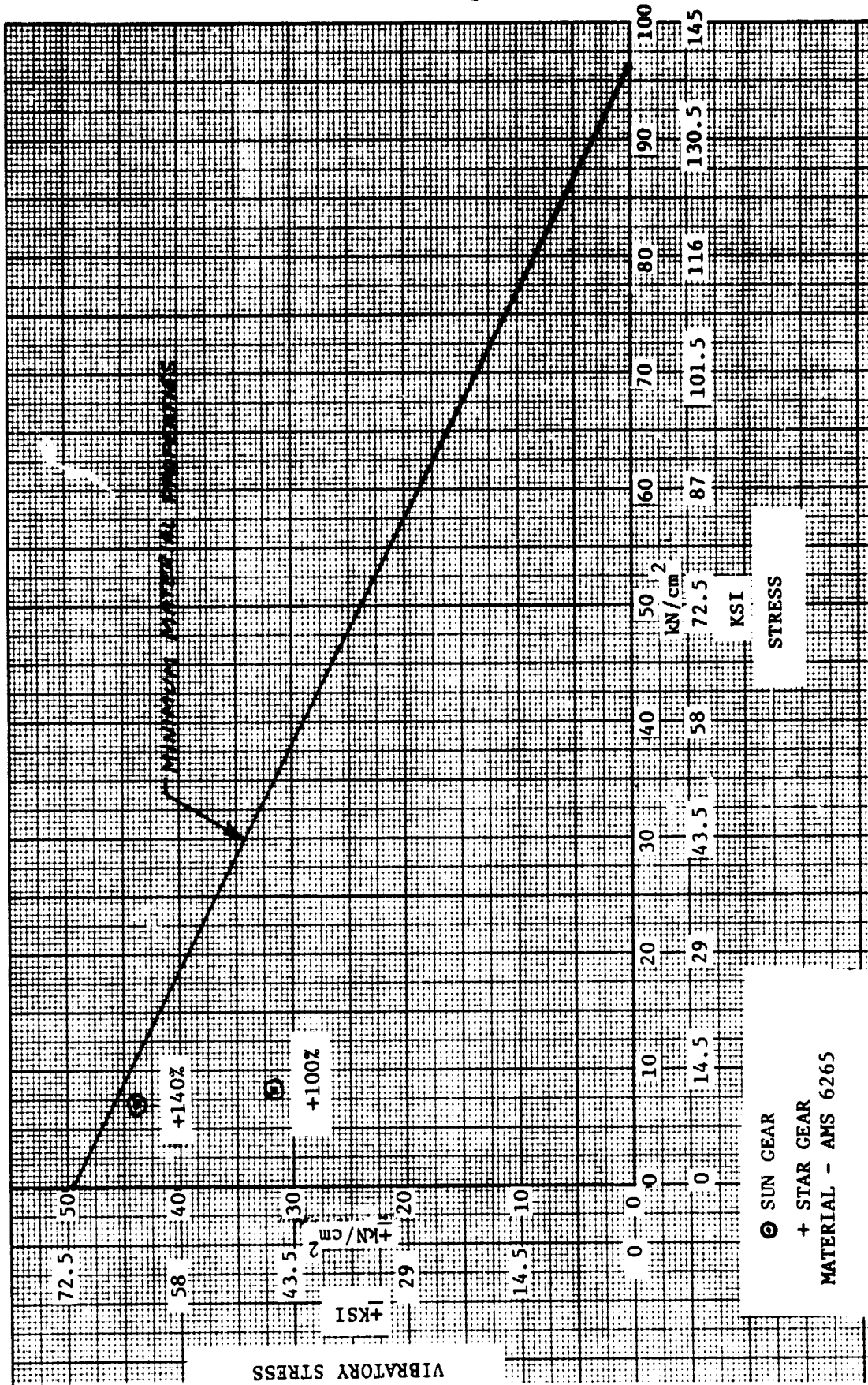

Figure 3-18. Sun And Gear "Combined" Stresses For 100% And 140% Torque
Class B (UTW) Reduction Gear

Ring Gear - Combined stresses for the ring gear are calculated in the same manner as those for the sun gear. Table 3-22 shows the tooth bending and valley stresses at the three points of maximum stress around the ring. The stresses when added together result in a stress range and an equivalent mean and vibratory stress. The stress data for both 100% and 140% torque are shown on Table 3-22 and plotted on a Goodman diagram, Figure 3-19. Vibratory margins for the ring gear are similar to, but slightly greater than, those for the sun gear.

Star Gear - Combined stress for the star gear involves a slightly different concept in valley stresses. This is due to the fact that the tooth is loaded on one side by the sun gear and the opposite side by the ring gear. As a conservative assumption the valley stresses are added to the bending stresses for either side, that is, A_1 and A_2 are added to B individually. Two stress cycles will occur for each revolution of the star gear.

Table 3-23 shows the valley and tooth bending stresses for the star gear as well as the combined stress values. Mean and vibratory stress data are plotted on the Goodman diagram shown on Figure 3-18. The vibratory margin is 1.60 for the 100% torque and 1.17 for the 140% torque point.

Again, considering the relatively conservative assumptions made in arriving at the "combined" stress, the margins are considered satisfactory.

3.2.4 Stresses Due to Flight

The effect of maneuver loads called out in Specification MIL-E-5007, with exception of catapult operation and a pitch velocity during flight of 1 rad/s, and an emergency condition of 2.5 fan blades out was investigated. Input data used for the analysis was supplied by General Electric from their dynamic analysis of the complete rotating system. In their analysis, the following assumptions were made.

1. No torque in the main reduction gears
2. No radial force between the gears
3. Ring gear rigidly attached to fan shaft
4. Sun gear rigidly attached to flex coupling

TABLE 3-22a

CLASS B (UTW) REDUCTION GEAR

RING GEAR "COMBINED" STRESS (N/cm²) (SI UNITS)

100% SPEED (329 RAD/S)

INCLUDES STRESS CONCENTRATION FACTORS

100% TORQUE

Location (Fig.3-12)	I	II	III	Equivalent
A1	+19,595	0	0	
A2	0	-19,595	0	+ 2,499
B	+ 7,662	- 7,160	+31,754	<u>+29,254</u>
Total	+27,258	-26,755	+31,754	

140% TORQUE

Location (Fig.3-12)	I	II	III	Equivalent
A1	+27,433	0	0	
A2	0	-27,433	0	- 2,908
B	+ 4,325	-16,425	+38,043	<u>+40,951</u>
Total	+31,758	-43,858	+38,043	

TABLE 3-22b
CLASS B (UTW) REDUCTION GEAR

RING GEAR "COMBINED" STRESS (PSI) (ENGLISH UNITS)

100% SPEED (3143 RPM)

INCLUDES STRESS CONCENTRATION FACTORS

100% TORQUE

Location (Fig.3-12)	I	II	III	Equivalent
A1	+28,420	0	0	
A2	0	-28,420	0	+ 3,625
B	+11,114	-10,385	+46,055	<u>+42,430</u>
Total	+39,534	-38,805	+46,055	

140% TORQUE

Location (Fig.3-12)	I	II	III	Equivalent
A1	+39,788	0	0	
A2	0	-39,788	0	- 4,218
B	+ 6,273	-23,823	+55,176	<u>+59,394</u>
Total	+46,061	-63,611	+55,176	

ORIGINAL PAGE IS
OF POOR QUALITY

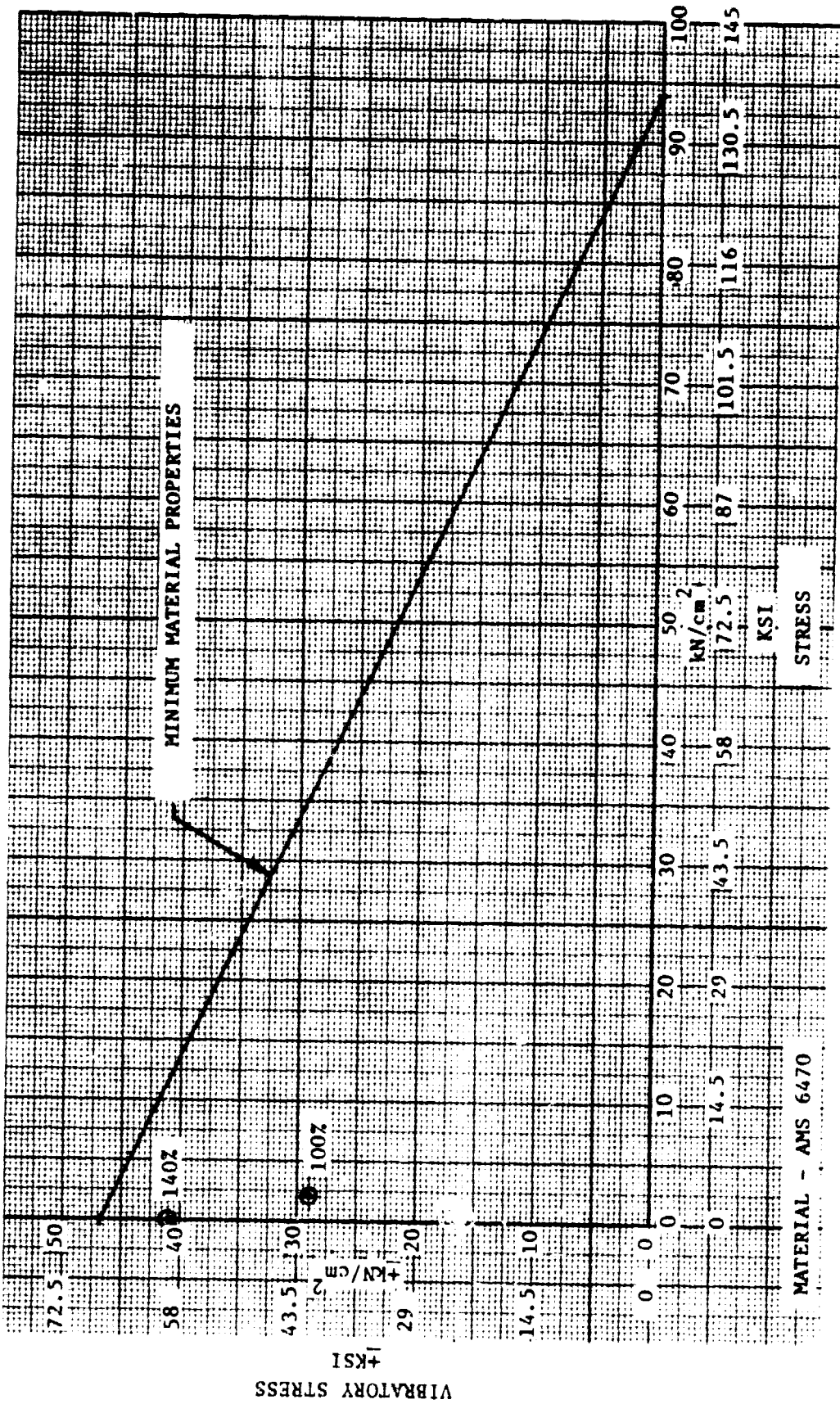

Figure 3-19. Ring Gear "Combined" Stress For 100% And 140% Torque Class B (UTW) Reduction Gear

TABLE 3-23a
CLASS B (UTW) REDUCTION GEAR

STAR GEAR "COMBINED" STRESS (N/cm²)(SI UNITS)

100% SPEED (1,107 RAD/S)

INCLUDES STRESS CONCENTRATION FACTOR

100% TORQUE

Location (Fig.3-12)	I	II	III	Equivalent
A1	+24,042	0	0	
A2	0	-24,042	0	+ 5,466
B	+10,446	+ 486	+14,176	<u>+29,022</u>
Total	+34,488	-23,556	+14,176	

140% TORQUE

Location (Fig.3-12)	I	II	III	Equivalent
A1	+33,659	0	0	
A2	0	-33,659	0	+ 3,247
B	+10,219	- 3,476	+15,441	+40,631
Total	+43,878	-37,383	+15,441	

TABLE 3-23b
CLASS B (UTW) REDUCTION GEAR

STAR GEAR "COMBINED" STRESS (PSI) (ENGLISH UNITS)

100% SPEED - (10,577 RPM)

INCLUDES STRESS CONCENTRATION FACTORS

100% TORQUE

Location (Fig.3-12)	I	II	III	Equivalent
A1	+34,870	0	0	
A2	0	-34,870	0	+ 7,928
B	+15,150	+ 705	+20,561	<u>+42,093</u>
Total	+50,020	-34,165	+20,561	

140% TORQUE

Location (Fig.3-12)	I	II	III	Equivalent
A1	+48,818	0	0	
A2	0	-48,818	0	+ 4,710
B	+14,822	- 5,402	+22,396	+58,930
Total	+63,640	-54,220	+22,396	

5. Star gear rotation not taken into account. The gears are assumed lumped weights.

GE data were supplied in the form of relative radial motion of the sun gear, star gear, and ring gear for 1 "G", 1 rad/s², 1 rad/s, and 1 blade out. The relative motion was converted to differential deflections at the ring-to-star mesh and the sun-to-star mesh. Table 3-24 shows the differential deflections for each particular load and also shows how the particular maneuvers combine for the maximum loading during flight and landing. In order to relate these deflections into forces, radial spring rates of the three components must be evaluated. The following table shows the radial deflections of the individual components under a 4448 N (1000 pound) load.

Component	Deflection	
	mm	mils
Sun	.1651	6.50
Star	.0191	0.75
Ring	.0305	1.20

Table 3-25 shows the summary of differential deflections and separating loads on the gears for the flight and landing conditions. In order to calculate the increase in load on the star gears, a load of 11863 N (2667 pounds) was applied by the ring gear to the carrier support and a load of 5583 N (1255 pounds) from the sun gear to the carrier. Since the relationship between the star gears and the sun and ring gear is not fixed, this load was applied to the carrier support at different angles from directly in line with a star to halfway between two stars. The maximum increase in separating load on an individual star is just under 13% of the design load. Converting this separating load into torque results in an increase in torque as follows:

Sun	5.9%
Ring	21.7%
Star	12.8%

Since the basic gearing was analyzed and found satisfactory for 100% and 140% torque, there should be no problems for these increases in torque at design

TABLE 3-24
 CLASS B (UTW) REDUCTION GEAR
 MANEUVER LOADS
 DIFFERENTIAL DEFLECTIONS
 (BASED ON G.E. DYNAMIC ANALYSIS)

SI UNITS

Maneuver	Ring to Star mm	Sun to Star mm
10G	.05334	.1524
14 Rad/Sec ²	.05842	.04572
1 Rad/Sec	.09398	.12192
2.5 Blades Out	.2159	.1397

ENGLISH UNITS

Maneuver	Ring to Star mils	Sun to Star mils
10G	2.1	6.0
14 Rad/Sec ²	2.3	1.8
1 Rad/Sec	3.7	4.8
2.5 Blades Out	8.5	5.5

CRITICAL LOAD CONDITIONS

Condition	Flight	Landing
Power	Maximum	100%
'G' Down	6	10
'G' Side	4	2
'G' Forward	4	10
Pitch Velocity	<u>±</u> 1 Rad/Sec	0
Pitch Acceleration	0	<u>±</u> 14 Rad/Sec ²
Yaw Acceleration	0	<u>±</u> 6 Rad/Sec ²

TABLE 3-25a
 CLASS B (UTW) REDUCTION GEAR
 MANEUVER LOADS
 (SI UNITS)

Load	Differential Deflection - mm	
	Ring to Star	Sun to Star
<u>Flight</u>		
7.21 'G'	.038	.109
1 Rad/Sec	.094	.122
Total	.132	.231
Separating Load	11,863 N	5,583 N
<u>Landing</u>		
10.2 'G'	.053	.155
15.2 Rad/Sec ²	.064	.051
Total	.116	.206
Separating Load	10,587 N	4,964 N
<u>Blade Out</u>		
Total	.216	.139
Separating Load	10,110 N	3,376 N

TABLE 3-25b
CLASS B (UTW) REDUCTION GEAR (ENGLISH UNITS)
MANEUVER LOADS

Load	Differential Deflection - Mils	
	Ring to Star	Sun to Star
<u>Flight</u>		
7.21 'G'	1.5	4.3
1 Rad/Sec	3.7	4.8
Total	5.2	9.1
Separating Load-Pounds	2667	1255
<u>Landing</u>		
10.2 'G'	2.1	6.1
15.2 Rad/Sec ²	2.5	2.0
Total	4.6	8.1
Separating Load-Pounds	2380	1116
<u>Blade Out</u>		
Total Rad/Sec ²	8.5	5.5
Separating Load-Pounds	4398	759

conditions. The instantaneous increase in torque on some stars will be offset by a decrease in others. Backing stresses for the design plus flight maneuver loads are shown on Table 3-26.

Table 3-27 shows the "combined" stresses for design plus flight maneuver loads. The Goodman diagram for the star and sun gear material is shown on Figure 3-20 and the data for the design point and design plus flight maneuver point are plotted. The vibratory margins indicate a satisfactory condition for this type of operation. The ring gear shows satisfactory margins of safety, as shown in Figure 3-21.

The loads resulting from 2.5 fan blades out (equivalent to 5 blades losing just their airfoil sections) are equal to an increase in torque as follows:

Sun Gear	7.8%
Ring Gear	28.5%
Star Gear	16.8%

This increase in torque will result in lower stresses than those reported for the 140% torque condition contemplated to be run during the demonstration tests and should cause no problems to the gearing.

3.2.5 Star Gear Carrier Support Stress

In the deformation and stress analysis of the fixed carrier support several assumptions were made. Radial and tangential gear loads were uniformly distributed along the width of the mating teeth. The resulting tangential loads applied by the sun and ring gear to the stars were uniformly distributed on the carrier support posts. Loads were analyzed separately and the results superimposed. A computer program (K SHELL 1) "Analysis of a Axisymmetric Shells under Symmetrical and Unsymmetrical Loading" was used in this analysis. The program is based on work by Arturs Kalnins, published in the Journal of Applied Mechanics, Vol. 31, September 1964.

Figure 3-22 is a sketch of the carrier support as it was analyzed. The outer flange (Item 11) was fixed and three types of load were applied, tangential load from the star gear, unbalance forces due to loss of fan blades, and a vertical "G" loading.

TABLE 3-26a
 CLASS B (UTW) REDUCTION GEAR
 BACKING STRESS (N/cm²)(SI UNITS)
 HOOP STRESS AT POINT NO. 1 FOR ALL COMPONENTS
 FLIGHT MANEUVERS PLUS 100% SPEED AND TORQUE

Gear	Load	At Mesh		Between Meshes	Equivalent
		Front	Back		
Sun	Rad.	- 5,341 N/cm ²	- 5,341 N/cm ²	+ 1,131 N/cm ²	+ 6,607 N/cm ² ± 5,668 N/cm ²
	Tang.	+ 4,864 N/cm ²	- 4,864 N/cm ²	-	
	Centri.	+ 9,028 N/cm ²	+ 9,028 N/cm ²	+ 9,028 N/cm ²	
	T.M.	+ 2,115 N/cm ²	+ 2,115 N/cm ²	+ 2,115 N/cm ²	
	Total	+10,667 N/cm ²	+ 938 N/cm ²	+12,275 N/cm ²	
Ring	Rad.	-21,956 N/cm ²	-21,956 N/cm ²	+13,908 N/cm ²	+ 6,449 N/cm ² +22,150 N/cm ²
	Tang.	+ 8,436 N/cm ²	- 8,436 N/cm ²	-	
	Centri	+10,670 N/cm ²	+10,670 N/cm ²	+10,670 N/cm ²	
	T.M.	+ 4,022 N/cm ²	+ 4,022 N/cm ²	+ 4,091 N/cm ²	
	Total	+ 1,172 N/cm ²	-15,701 N/cm ²	+28,599 N/cm ²	
Star	Rad	- 4,172 N/cm ²	- 4,172 N/cm ²	+ 2,381 N/cm ²	+ 4,572 N/cm ² ± 5,149 N/cm ²
	Tang.	+ 3,746 N/cm ²	- 3,746 N/cm ²	-	
	Centri	+ 7,341 N/cm ²	+ 7,341 N/cm ²	+ 7,341 N/cm ²	
	Total	+ 6,915 N/cm ²	- 577 N/cm ²	+ 9,722 N/cm ²	
Abbreviations: Radial - Rad Tangential - Tang Centrifugal - Centri Toroidal Moment - T.M.					

TABLE 3-26b

CLASS B (UTW) REDUCTION GEAR

BACKING STRESS (PSI) (ENGLISH UNITS)

HOOP STRESS AT POINT NO. 1 FOR ALL COMPONENTS

FLIGHT MANEUVERS PLUS 100% SPEED AND TORQUE

Gear	Load	At Mesh		Between Meshes	Equivalent
		Front	Back		
Sun	Rad.	-7,746	-7,746	+1,641	
	Tang.	+7,055	-7,055	-	
	Centri.	+13,094	+13,094	+13,094	+9,582
	T.M.	+3,068	+3,068	+3,068	<u>+8,221</u>
	Total	+15,471	+1,361	+17,803	
Ring	Rad.	-31,844	-31,844	+20,172	
	Tang.	+12,236	-12,236	-	
	Centri	+15,475	+15,475	+15,475	+9,354
	T.M.	+5,833	+ 5,833	+ 5,933	<u>+32,126</u>
	Total	+1,700	-22,772	+41,480	
Star	Rad	-6,051	-6,051	+3,453	
	Tang.	+5,433	-5,433	-	+6,631
	Centri	+10,647	+10,647	+10,647	<u>+7,468</u>
	Total	+10,029	-837	+14,100	
Abbreviations:					
Radial - Rad		Centrifugal - Centri			
Tangential - Tang		Toroidal Moment - T.M.			

TABLE 3-27
 CLASS B (UTW) REDUCTION GEAR
 GEAR "COMBINED" STRESSES
 100% DESIGN PLUS MANEUVER LOADS
 INCLUDES STRESS CONCENTRATION FACTORS

SI UNITS

Gear	Location (Fig.3-12)	Stress - N/cm ²			
		I	II	III	Equivalent
Sun	A1	+29,630	0	0	8,705
	A2	0	-29,630	0	+36,926
	B	+16,001	- 1,408	+18,412	
	Total	+45,630	-28,222	+18,412	
Ring	A1	+23,371	0	0	
	A2	0	-23,371	0	- 2,011
	B	+ 1,758	-23,551	+42,899	+44,911
	Total	+25,129	-46,922	+42,899	
Star	A1	+28,644	0	0	
	A2	0	-28,644	0	+ 4,753
	B	+10,372	- 866	+14,582	+34,263
	Total	+39,017	-29,510	+14,582	

ENGLISH UNITS

Stress - PSI					
Sun	A1	+42,974	0	0	12,625
	A2	0	-42,974	0	+53,557
	B	+23,207	- 2,042	+26,705	
	Total	+66,181	-40,932	+26,705	
Ring	A1	+33,897	0	0	
	A2	0	-33,897	0	- 2,917
	B	+ 2,550	-34,158	+62,220	+65,138
	Total	+36,447	-68,055	+62,220	
Star	A1	+41,545	0	0	
	A2	0	-41,545	0	+ 6,894
	B	+15,044	- 1,256	+21,150	+49,695
	Total	+56,589	-42,801	+21,150	

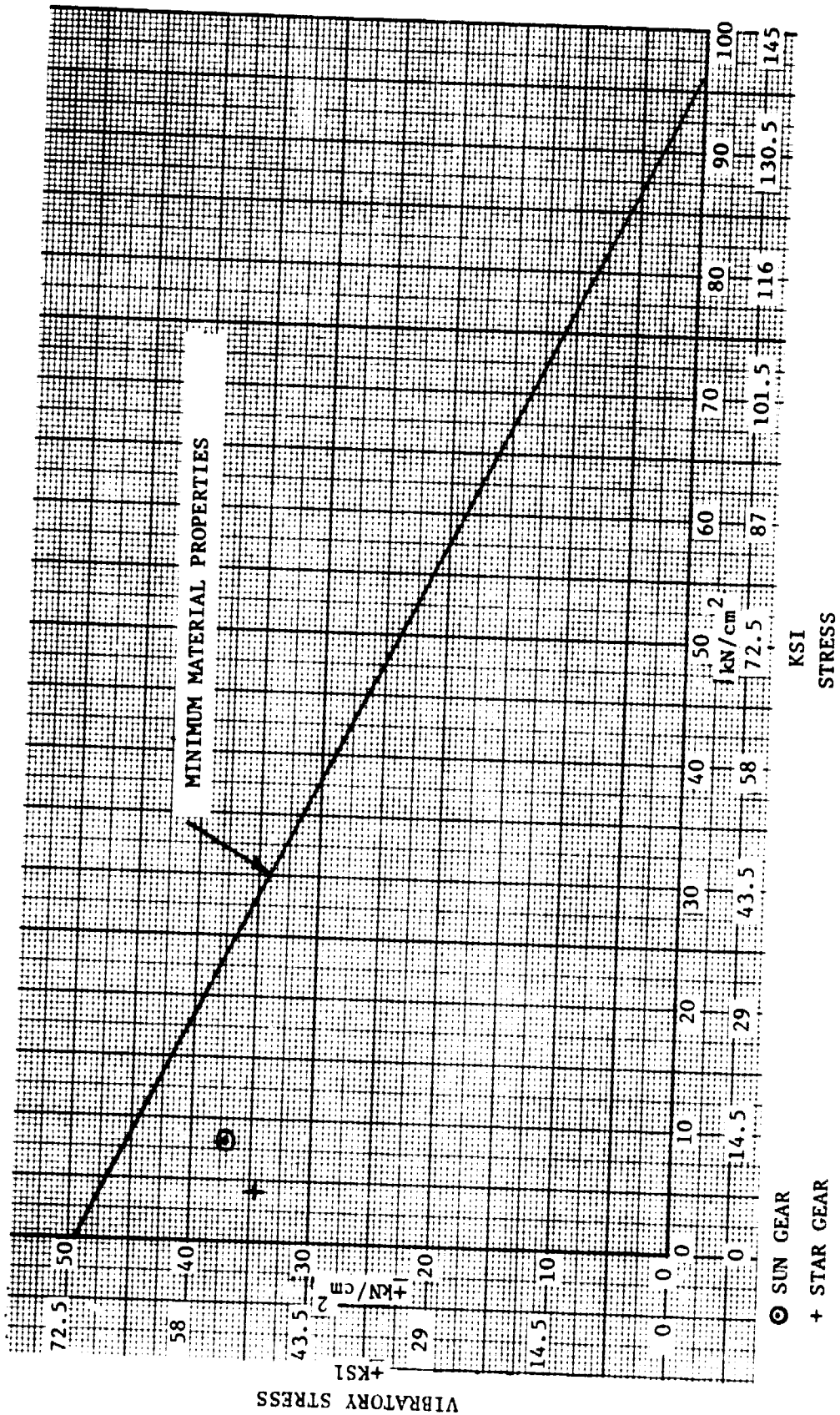

MATERIAL - AMS 6265

Figure 3-20. Sun And Star Gear "Combined" Stresses With Design Plus Maneuver Loads Class B (UTW) Reduction Gear

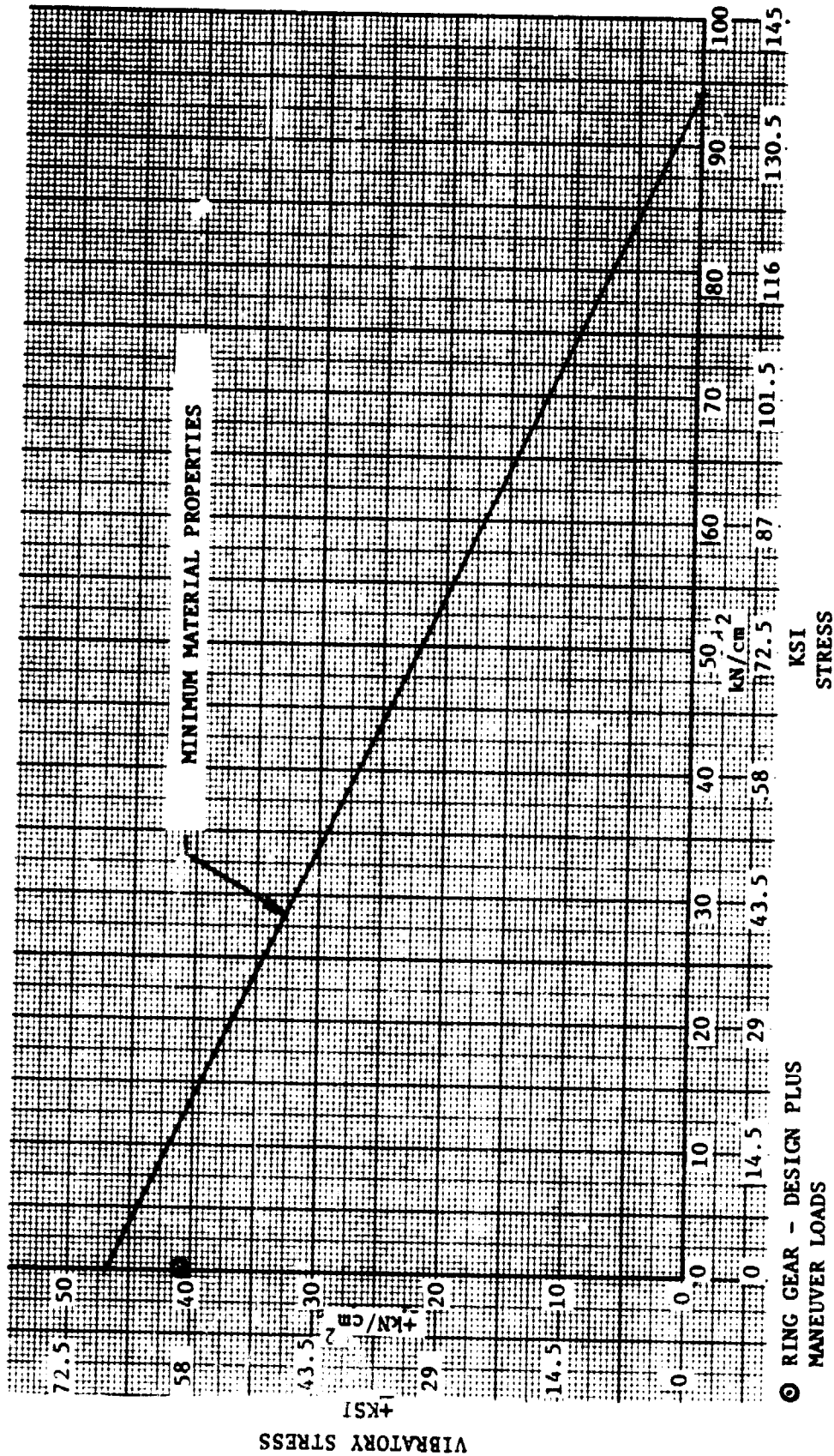
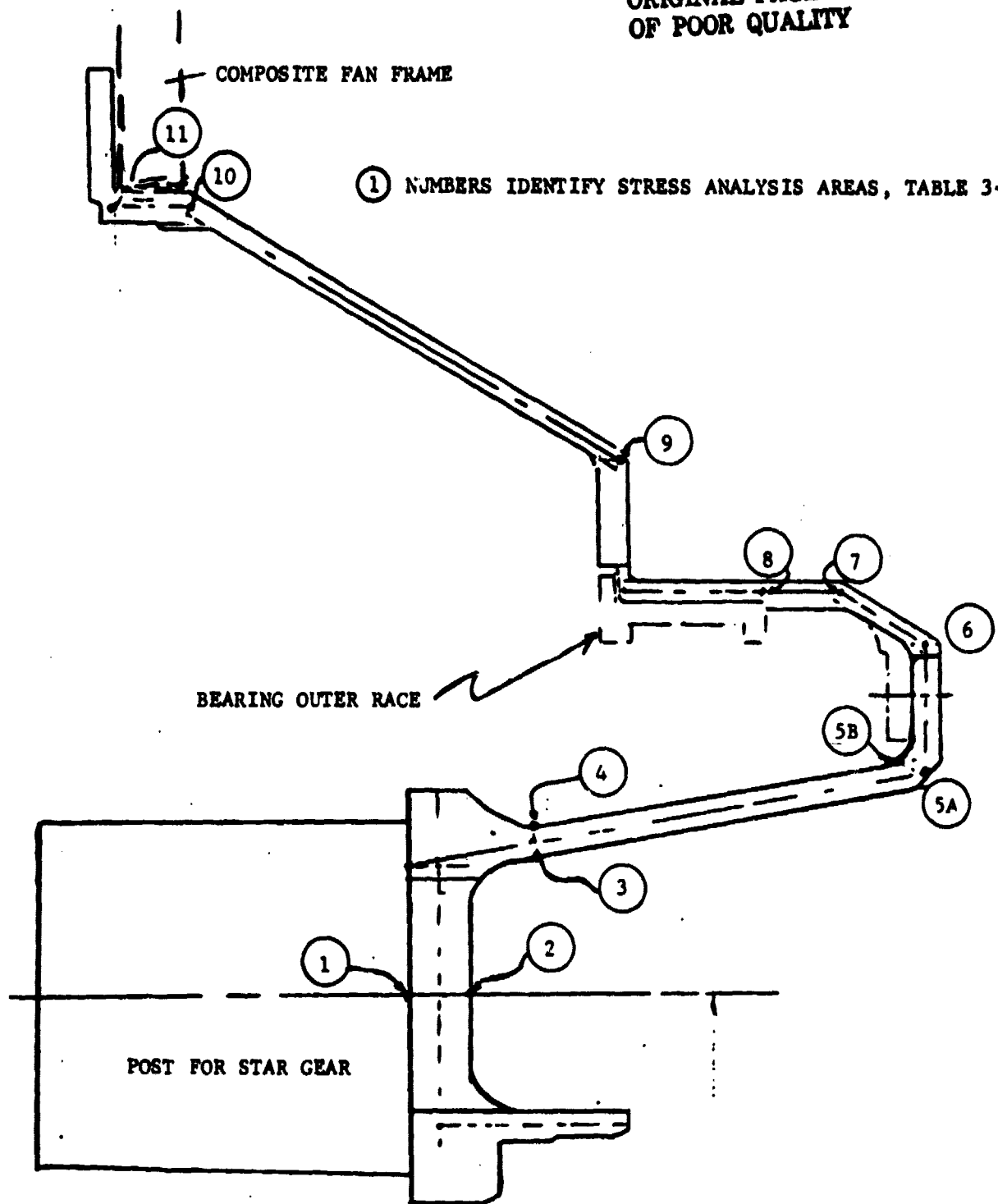

Figure 3-21. Ring Gear "Combined" Stress With Design Plus Maneuver Loads
Class B (UTW) Reduction Gear

ORIGINAL PAGE IS
OF POOR QUALITY



① NUMBERS IDENTIFY STRESS ANALYSIS AREAS, TABLE 3-28.

Figure 3-22, Class B (UTW) Reduction Gear
Star Gear Carrier Support Structure

Results of analysis are shown in Table 3-28. For the normal torque loading the maximum equivalent stress occurs in the post at its base with a value of 4559 N/cm^2 (8551 psi) due to the out of plane bending load. These stresses are essentially steady and minimal vibratory stresses are expected. The stresses are low enough to not cause any concern with respect to stress concentration factors and overload conditions. The minimum material property for the carrier, AMS 6415 RC 32 is 91010 N/cm^2 (132,000 psi) yield strength.

For a 10 "G" vertical load which is equivalent to a load of 4448 N (1000 pounds) applied at the middle of each of the six posts, the maximum equivalent stress is 7950 N/cm^2 (11,531 psi), well within minimum material allowables when stress concentration factors and overload situations are taken into consideration. Data furnished by General Electric indicated that a bearing load of 200,170 N (45,000 pounds) represents the effect of operating with 2.5 fan blades out. The highest stress in the carrier will occur at point 5B where the effective stress is 6287 N/cm^2 (9118 psi). Because the blade out force rotates, the stress at point 5 will be vibratory. With a minimum endurance strength of $\pm 51,710 \text{ N/cm}^2$ ($\pm 75,000$ psi) the blade out operation should not damage the carrier.

3.2.6 Flex Coupling

The sun gear is attached to the power turbine drive shaft by means of a diaphragm type flexible coupling. A common flexible coupling is used for both the UTW and OTW reduction gears. The shell computer program used to analyze the carrier support was also used to analyze the coupling. Figure 3-23 shows a model of the coupling as it was set up for analysis. Various sections of the coupling were modeled as cones and cylinders with constant or variable thickness. Three loads were applied to the coupling at the sun gear spline area; tangential and radial loads due to the torque and a vertical load of 4448 N (1000 pounds). Loads were applied separately at speed. Vertical load was used to relate vertical motion of the spline to stresses throughout the coupling. Motions or deflections of the splines as a function of blade out and maneuvers were obtained from General Electric.

TABLE 3-28
 CLASS B (UTW) REDUCTION GEAR
 STAR GEAR CARRIER SUPPORT STRESS
 100% DESIGN PLUS MANEUVER LOADS

SI UNITS

Load	Location (Fig. 3-22)	Hoop	Stress - N/cm ²		Equivalent
			Longitudinal	Shear	
100% Torque	Post	-	3,374	+1,771	4,560
	1	-2,959	-3,420	+ 432	3,300
	2	+2,225	+2,892	- 429	2,726
	3	+1,022	+ 932	+3,354	5,896
	4	- 422	-2,415	+2,752	5,265
	5A & 5B	-	-	+1,083	1,876
2.5 Blade Out	5A	- 265	-6,350	+ 518	6,287
	5B	+3,664	+6,411	+ 86	5,573
10 'G' Down	3	+ 476	+ 771	+ 676	1,351
	4	+ 103	- 426	+ 475	956
	5A	-4,771	-7,099	+ 47	6,269
	5B	- 171	+7,717	+ 877	7,950

ENGLISH UNITS

Load	Location (Fig. 3-22)	Hoop	Stress - PSI		Equivalent
			Longitudinal	Shear	
100% Torque	Post	-	4,894	+2,568	6,613
	1	-4,291	-4,960	+ 627	4,786
	2	+3,228	+4,194	- 622	3,954
	3	+1,482	+1,352	+4,864	8,551
	4	- 612	-3,502	+3,992	7,636
	5A & 5B	-	-	+1,571	2,721
2.5 Blade Out	5A	- 384	-9,210	+ 752	9,118
	5B	+5,314	+9,298	+ 125	8,083
10 'G' Down	3	+ 690	+1,118	+ 980	1,959
	4	+ 150	- 618	+ 689	1,386
	5A	-6,920	-10,296	+ 68	9,092
	5B	- 248	+11,193	+1,272	11,531

ORIGINAL PAGE IS
OF POOR QUALITY

① NUMBERS IDENTIFY STRESS ANALYSIS AREAS, TABLES 3-29 AND 3-30.

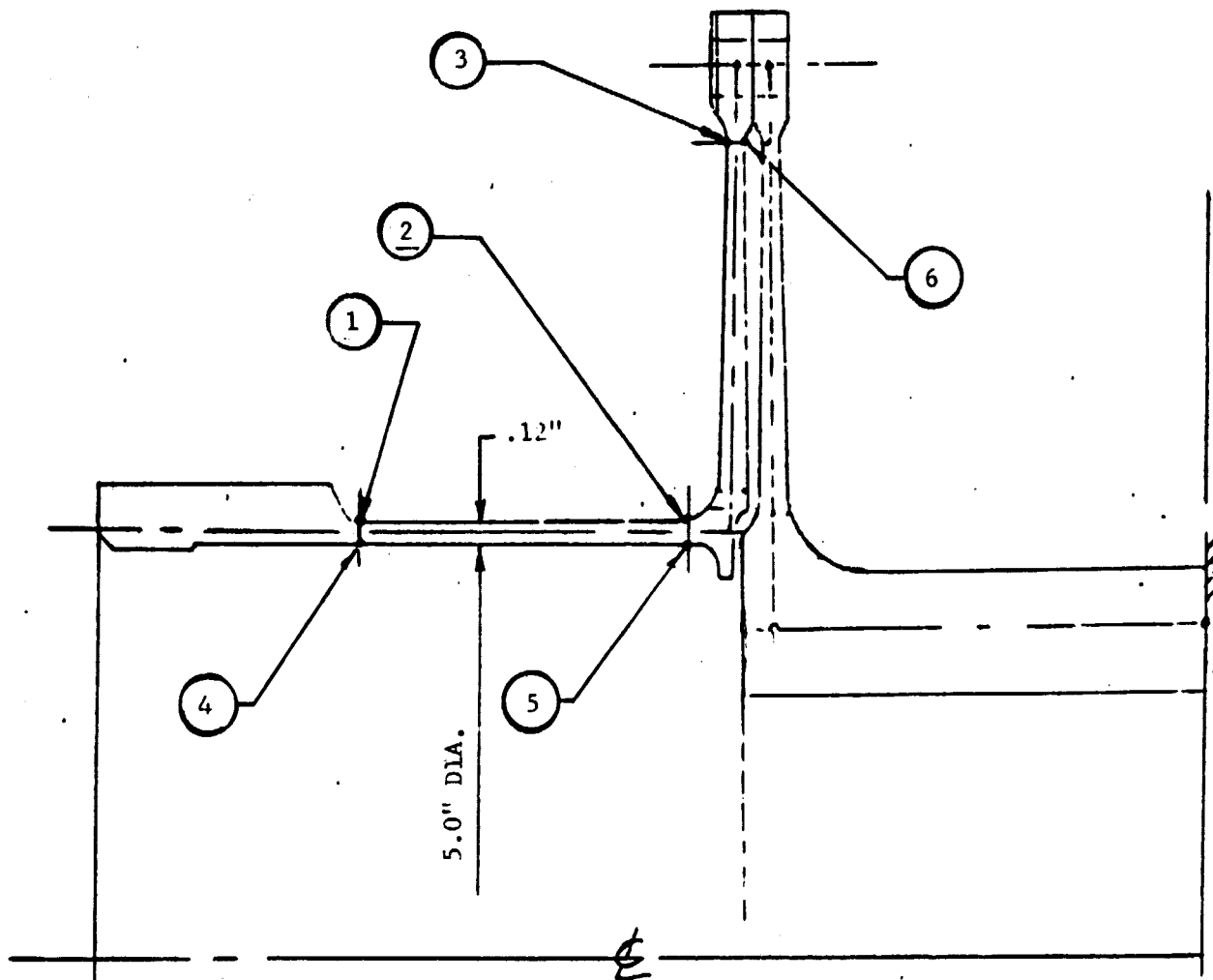

Figure 3-23 Class A (OTW) And Class B (UTW) Flexible Coupling.
Stress Analysis Areas

Data from General Electric were received in the form of relative deflections between the sun and star gears (see Table 3-24). Knowing the individual spring rates of the sun and star gear, the combined spring rate was calculated for a 4448 N (1000 pound) load. The total deflection is 0.355 mm (0.014 inches). Therefore, the stresses in the coupling for 4448 N (1000 pound) load are directly related to the sun-to-star differential deflection of 0.355 mm (0.014 inches).

Table 3-29 shows the coupling stresses for normal operation and 140% torque. Since the same identical coupling is used for both the UTW and OTW designs, the data presented here are for the higher of the two, the OTW. The OTW unit speed is about 3% higher and torque is 26% higher than the UTW unit values. The maximum stress intensity is 22738 N/cm^2 (32,979 psi), occurs at point No. 2, outer surface of the cylindrical section at intersection with the diaphragm fillet, and is satisfactory based on minimum material properties (AMS 6265) of $83,800 \text{ N/cm}^2$ (121,550 psi) yield strength.

Flexible coupling stress values for maneuver and blade out loads are shown on Table 3-30. The highest stress intensity or equivalent stress occurs at point 5, inner surface of the cylindrical section at intersection with the diaphragm fillet, and is 6931 N/cm^2 (10,053 psi) for maneuvers alone and 5195 N/cm^2 (7534 psi) for 2.5 fan blades out. Combining the normal design load and the flight maneuver load as a vibratory would result in a mean stress of $17,691 \text{ N/cm}^2$ (25,659 psi) and a vibratory of $\pm 1523 \text{ N/cm}^2$ (± 2209 psi) (without stress concentration factor) at point 5; point 2 would be $18,366 \text{ N/cm}^2$ (26,638 psi), $\pm 608 \text{ N/cm}^2$ (± 882 psi). If this data were plotted on the Goodman diagram shown on Figure 3-13, the vibratory margin would be over 20. The 2.5 fan blades out would result in a stress condition similar to design plus maneuver load condition and would not result in any stress problems for the flexible coupling.

3.3 Deflection Analysis

As discussed in Section 3.1, a key feature of epicyclic gearing systems designed by Curtiss-Wright is a controlled deflection of the gear components

TABLE 3-29a
 CLASS B (UTW) REDUCTION GEAR
 FLEXIBLE COUPLING STRESS (SI UNITS)
 CLASS A (OTW) LOADING
 100% SPEED (834 RAD/SEC)

Point (Fig.3-23)	Stress - N/cm ²			
	Hoop	Longitudinal	Shear	Equivalent
1	419	-1,600		
2	+6,652	-2,197		
3	+4,321	+2,036		
4	+1,379	+1,600		
5	+6,550	+2,197		
6	+3,036	- 565		
<u>100% Torque (15,368 N-m)</u>				
1			+ 8,830	15,405
2			+ 8,830	17,251
3			+ 2,552	5,794
4			+ 8,830	15,368
5			+ 8,830	16,348
6			+ 2,552	5,550
<u>140% Torque (21,515 N-m)</u>				
1			+12,293	21,371
2			+12,293	22,738
3			+ 3,574	7,234
4			+12,293	21,344
5			+12,293	22,060
6			+ 3,574	7,040

TABLE 3-29b
 CLASS B (UTW) REDUCTION GEAR
 FLEXIBLE COUPLING STRESS (ENGLISH UNITS)
 CLASS A (OTW) LOADING
 100% SPEED (7962 RPM)

Point (Fig. 3-23)	Stress - PSI			
	Hoop	Longitudinal	Shear	Equivalent
1	+608	-2,320		
2	+9,648	-3,186		
3	+6,267	+2,953		
4	+2,000	+2,320		
5	+9,500	+3,186		
6	+4,404	-820		
100% Torque (136,016 in.-lb.)				
1			+12,807	22,343
2			+12,807	25,021
3			+3,702	8,403
4			+12,807	22,289
5			+12,807	23,711
6			+3,702	8,049
140% Torque (190,422 in.-lb.)				
1			+17,829	30,996
2			+17,829	32,979
3			+5,183	10,492
4			+17,829	30,957
5			+17,829	31,996
6			+5,183	10,211

TABLE 3-30
 CLASS B (UTW) REDUCTION GEAR
 FLEXIBLE COUPLING STRESS
 MANEUVER AND BLADE OUT LOADS
 SI UNITS

Point (Fig.3-23)	Hoop	Longitudinal	Stress (N/cm ²) Shear	Equivalent
Maneuver Load				
1	-1,458	-1,738	- 165	1,642
2	+4,394	+7,393	- 194	6,449
3	-1,911	-4,024	- 39	3,487
4	- 498	+1,320	+1,384	2,957
5	+ 38	-6,795	+ 733	6,931
6	+1,050	+4,306	+ 67	3,890
2.5 Blade Out				
1	- 878	-1,047	- 99	988
2	+4,370	+5,568	- 335	5,109
3	-1,149	-2,421	- 32	2,099
4	- 299	+ 793	+ 856	1,776
5	0	-5,103	+ 561	5,195
6	+ 631	+2,590	+ 53	2,341

ENGLISH UNITS

Point (Fig.3-23)	Hoop	Longitudinal	Stress - PSI Shear	Equivalent
Maneuver Load				
1	-2,115	-2,521	- 239	2,381
2	+6,373	+10,722	- 281	9,353
3	-2,772	-5,837	- 57	5,058
4	- 723	+1,915	+2,007	4,289
5	+ 55	-9,855	+1,063	10,053
6	+1,523	+6,245	+ 97	5,642
2.5 Blade Out				
1	-1,273	-1,518	- 143	1,433
2	+6,338	+8,076	- 486	7,410
3	-1,666	-3,512	- 46	3,044
4	- 434	+1,150	+1,242	2,576
5	0	-7,401	+ 813	7,534
6	+ 915	+3,757	+ 77	3,396

under load to insure uniform loading across the face width of all mating gears. Sun and ring gear designs were analyzed for controlled deflections. Two separate analyses were made; the first calculated the toroidal twist resulting from the gear mesh separating force, and the second calculated the effect of centrifugal forces.

A time-sharing computer program is used to calculate the deflection (or rotation) of a ring under the influence of discretely positioned toroidal moments. Toroidal moments lie in the plane of the cross-section of the ring causing a rotation of the plane. The equations used for the analysis are taken from Biezero and Grammel "Engineering Dynamics", Vol. II. Centrifugal effects are taken from a shell computer program. The shell program analyzes axisymmetric shells (combinations of rings, plates, cones and cylinders connected in series) which are subject to symmetrical radial forces.

Results of the analyses are shown on Table 3-31. Data are shown for the two major contributors of deflection and given in the form of a radial slope in the axial direction as well as the effective tangential slope on the direction of rotation. For both gears the centrifugal forces cause a twist opposite to that due to the gear separating forces. For the ring gear the centrifugal effect is less than 2% of the final twist while for the sun gear the effect is almost 25%.

Deformation analysis of the star gear journal under load was done in the following manner. First the journal or post was analyzed as a cantilever beam with the radial and tangential loads from the sun and ring gears applied as uniformly distributed loads. This results in an average slope of the carrier support post of 236×10^{-6} in./in. in a tangential or torque direction. The contribution of the carrier backup structure was calculated by applying a tangential load in the plane of the carrier ring and a couple at each of the six posts. The analysis was done using the K SHELL 1 computer program which can apply discrete loads on axisymmetric shells. Results of this analysis showed the post would have an additional slope due to the backup ring of 27×10^{-6} in./in., an increase of about 10%. Table 3-31 shows that for the design condition deflections of the three gear components will result in

TABLE 3-31
 CLASS B (UTW) REDUCTION GEAR
 GEAR TOOTH DEFLECTION

Gear	Load	SLOPE 10^{-6} IN./IN	
		Axial	Tangential
Sun	Radial	- 461.6	
	Centrifugal	+ 90.1	
	Total	- 371.5	- 124.0
Ring	Radial	+1748.6	
	Centrifugal	- 22.5	
	Total	+1726.1	+ 575.0
Carrier Support	Post		+ 236.0
	Backing Ring		+ 27.0
	Total		+ 263.0

the following tangential slopes of the gear tooth contact lines:

Ring	575×10^{-6}	in./in.
Carrier - Star	263×10^{-6}	in./in.
Sun	124×10^{-6}	in./in.

The star gear design has a spherical bearing between the carrier post and star gear. This will accommodate any mismatch between the deflections of the three gear elements without excessive skew. As a result, uniform tooth loading patterns should be experienced and the service life of the unit will be satisfactory.

3.4 Natural Frequencies

Excitation of ring and sun gear bending natural frequencies can be a source of excessive vibration and dynamic stress in planetary gear sets. The prime mode of vibration for the two ring type gears will be the six diameter mode (12 nodes). The estimated natural frequency values for the initial design are:

Ring Gear	960 hertz
Sun Gear	8,300 hertz

Figure 3-24 shows the interference diagram for the gears with the two major excitation sources; the six star gear passing frequency and the gear meshing frequency. At the bottom of the figure is the expected speed range of the unit. The star passage excitation (six times the speed of the gear) will not excite either gear. The gear tooth meshing frequency will excite the ring gear at 10% speed, well below the operating speed range. The sun gear natural frequency point within the operating speed range (93% speed) raised some concern about the possibility of an undesirable noise or wear condition. Since the natural frequency is a function of the gear rim thickness, a decision was made to increase the thickness by a minimum of 2.54 mm (0.1 inch), approximately 18%, to raise the natural frequency to 10,870 hz. An experimental frequency check on the sun gear prior to final machining of the rim indicated an actual natural frequency somewhat lower than calculated. To compensate for the variation between the actual and calculated natural frequencies an additional 1.5 mm (0.06 inch) was left inside the gear rim. This raises the six diameter mode frequency of the sun gear to approximately the 10,870 hz desired and results in an interference with the tooth meshing frequency at 19% above rated 100% speed and 11% above maximum operating speed which is considered acceptable.

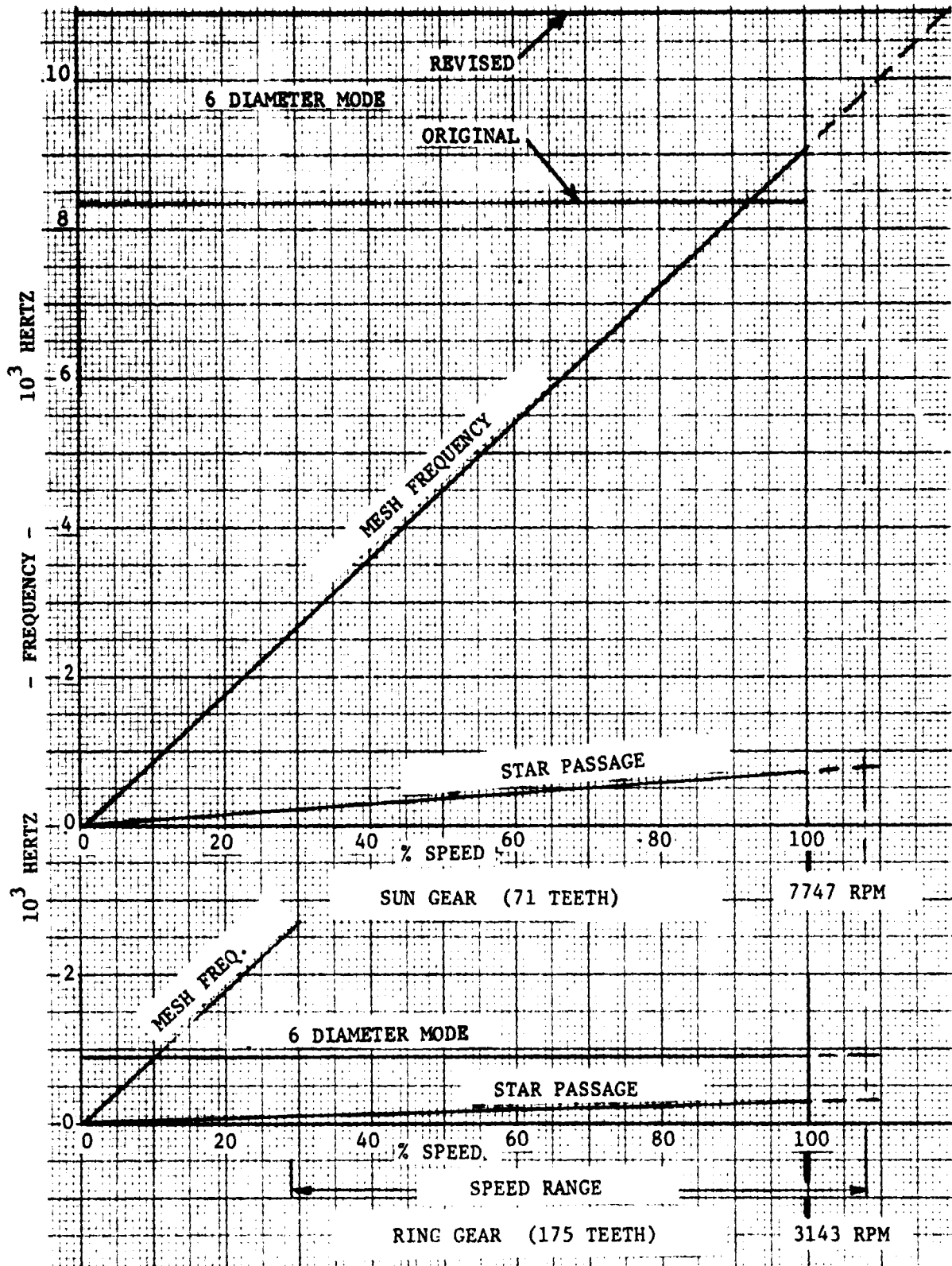

Figure 3-24. Interference Diagram Class B (UTW) Reduction Gear

ORIGINAL PAGE IS
OF POOR QUALITY

4.0 DETAILED DESIGN - OTW REDUCTION GEAR

4.1 Mechanical Design

Results of the preliminary design phase were integrated into the General Electric Company overall QCSEE program and after a series of updatings and exchanges of results, the design objectives shown in Table 4-1 were established for the OTW reduction gear detailed design. Additional performance requirements for the experimental engine operation are shown in Table 4-2. Final configuration of the OTW gear assembly is defined by Figures 4-1 (assembly) and 4-2 (involute gear tooth layout). The splines are the same as for the UTW unit, Figure 3-3 (involute spline layout). Interface points between the reduction gear and engine, i.e., input coupling, ring gear spline, star gear support flange and the oil supply pipe, are identical to those of the UTW unit. Also, the sun gear coupling and spline lock ring are common to both the OTW and UTW reduction gears. Gear speed and bearing load data at the 100% power, 100% speed take-off condition are shown in Table 4-3. Basic size at 100% is 12,703 kW (17,035 hp) output with an output speed of 3862 rpm and a gear ratio of 2.062:1 (7963 rpm input speed). Bill of Material No. 211 is included as Appendix C. Basic gear data, stresses and materials are listed in Table 4-4. Details of the gear tooth involute profile modifications for the sun gear, star gear and ring gear are shown by Figures 4-3, 4-4 and 4-5, respectively. Gear material stresses presented in Table 2-8 are applicable to the final design. Calculated gear stresses occurring during the experimental engine test operation are shown in Table 4-5. Stresses shown here differ only slightly from those for the preliminary design phase shown in Table 2-9.

The maximum bending stress of $33,345 \text{ N/cm}^2$ (48,363 psi) occurs in the sun gear during the 140% turbine power specified for one hour during the experimental engine operation, a total of 3.8×10^6 cycles. This is lower than the AGMA allowable stress of $38,691 \text{ N/cm}^2$ (56,117 psi) for AMS 6265 material under single direction loading, Table 2-8. The maximum bending stress in the star gear of $30,112 \text{ N/cm}^2$ (43,674 psi) occurs during the same operation noted above for the sun gear. Although this stress is greater than the AGMA allowable of $26,958 \text{ N/cm}^2$ (39,100 psi) for loading in both directions, Table 2-8, it occurs for only 9.0×10^5 cycles and is acceptable. The maximum contact stress of 104,287

TABLE 4-1

CLASS A (OTW) REDUCTION GEAR

DETAIL DESIGN OBJECTIVES

FLIGHT CYCLE

CONDITION	POWER %	SPEED %	TIME %	OIL IN TEMP	
				°R	°F
START	0	0-30	1.11	-	-
IDLE	10	67.	6.89	339	150
TAKE-OFF	100.	100.	2.71	355	180
CLIMB	79.00	95.	22.22	355	180
CRUISE	57.00	94.	31.11	375	216
DESCENT	3.34	35	22.22	396	254
APPROACH	54.	82.	6.67	385	180
REVERSE	100.	100.	0.18	355	180
IDLE	10	67.	6.89	339	150
100% FAN POWER = 12,703 kW (17,035 hp)					
100% FAN SPEED = 404.4 rad/s 3862 rpm					

TABLE 4-2

CLASS A (OTW) REDUCTION GEAR

DETAIL DESIGN OBJECTIVES

EXPERIMENTAL ENGINE CYCLE

HOURS	% TIME	% TURBINE SPEED	% TURBINE POWER
1	0.04	105	100
1	0.05	100	140
15	0.56	100	130
15	0.56	100	110
150	5.59	100	100
500	18.64	90	80
1000	37.28	75	50
1000	37.28	30	10
100% Turbine Power = 12,813 kW (17,183 hp)			
100% Turbine Speed = 833.8 rad/s (7962 rpm)			

ORIGINAL PAGE IS
OF POOR QUALITY

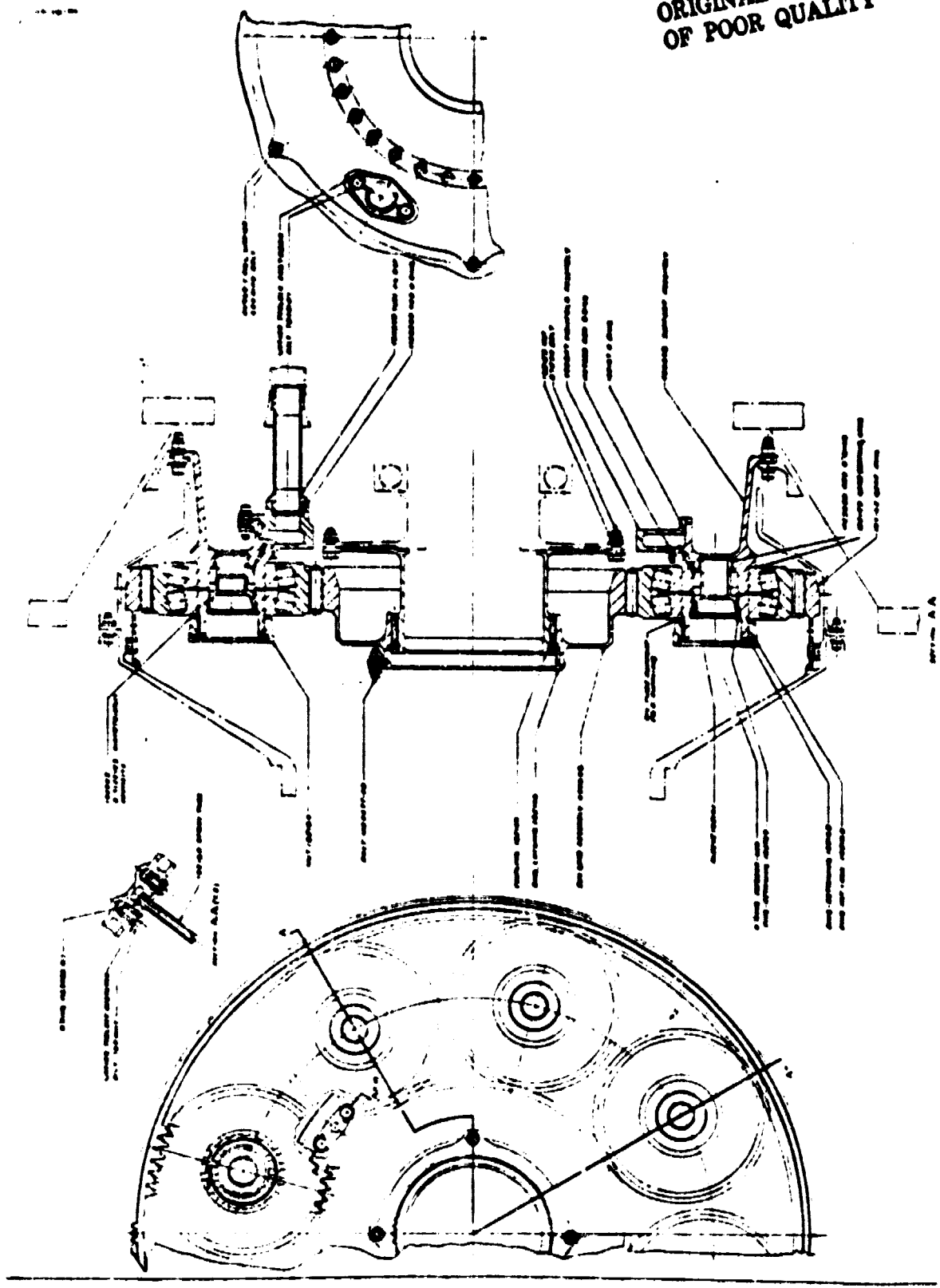
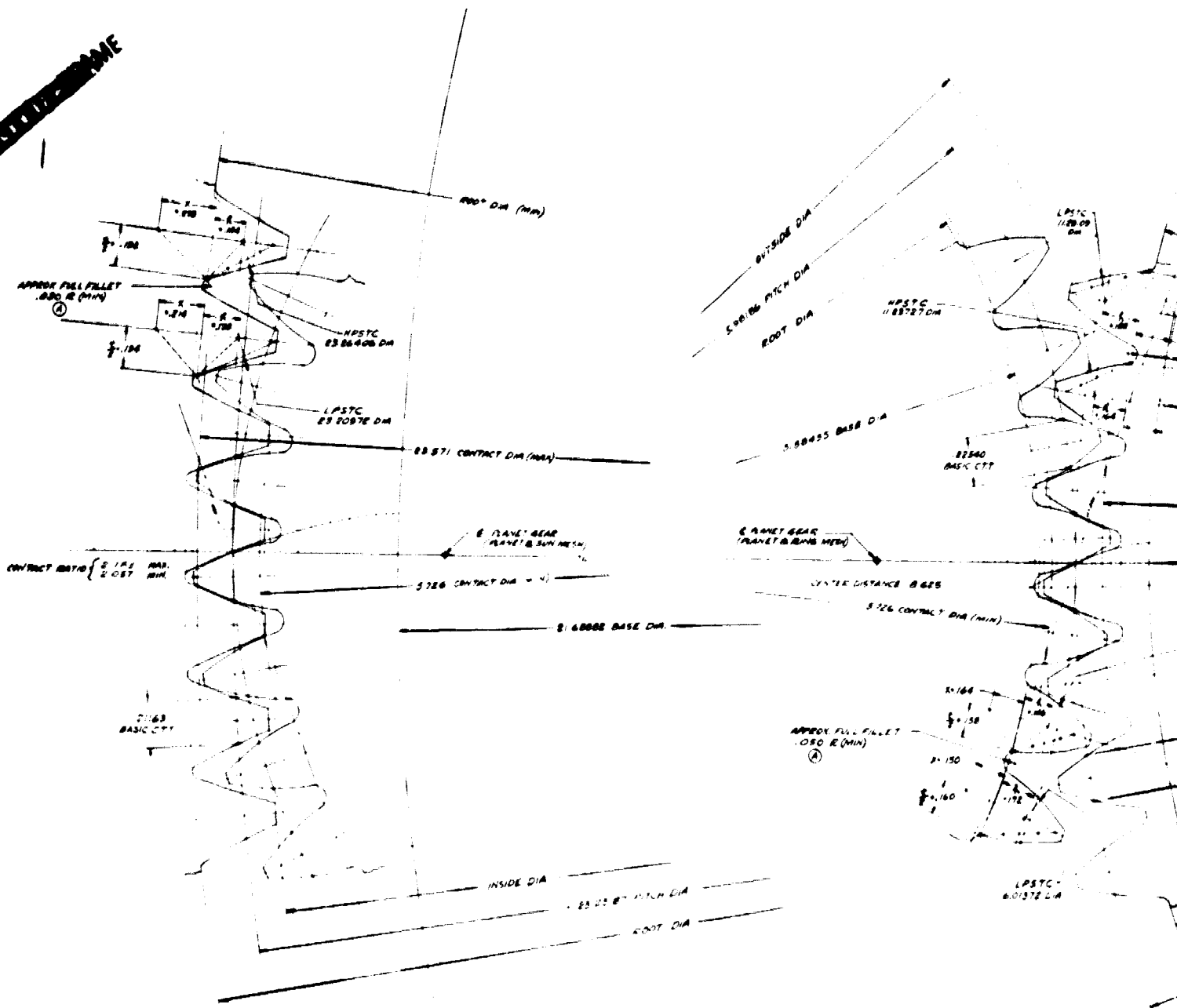

Figure 4-1. QCSEE Main Reduction Gear Over-The-Wing (OTW) Unit.

ORIGINAL PAGE IS OF POOR QUALITY



ORIGINAL PAGE IS OF POOR QUALITY

FOLDOUT FRAME
J

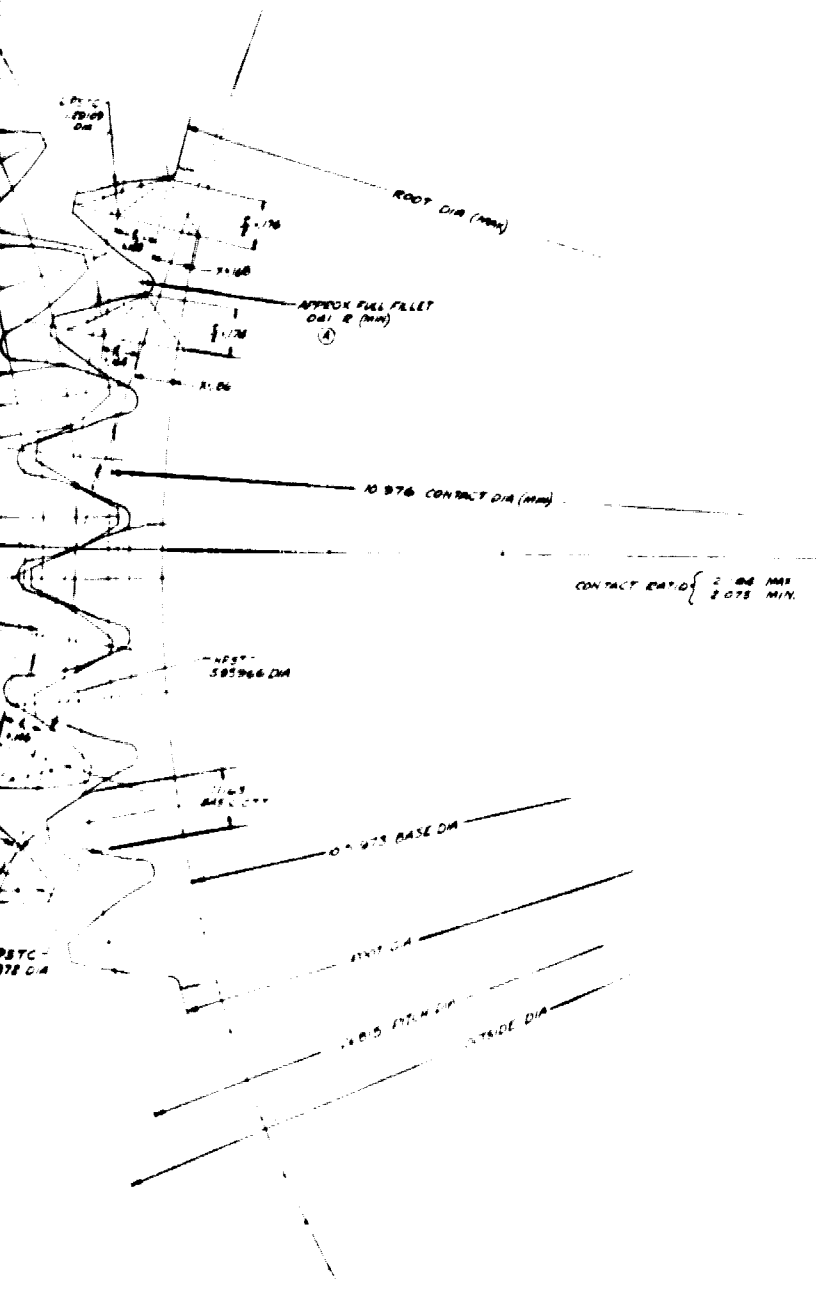

DETAIL DATA				
	UNIT	VAL	MIN	MAX
N	NUMBER OF TEETH	48		
P	CAMICAL PITCH	1.000	0.999	1.001
Q	PRESSURE ANGLE	20		
Ca	PITCH DIAMETER	100.00	99.996	100.004
Cl	ENTER DIA	80.00	80.00	80.00
T	TOOTH THICKNESS	2.00	1.990	2.010
*	WALN THICKNESS	0.125	0.125	0.125
R	BACK LASH	0.000	0.000	0.000
My	BASE FILM	0.000	0.000	0.000
Ca	BASE DIA	100.00	100.00	100.00
W	WIRE SIZE	0.00	0.00	0.00
V	WIRE HEAD	0.00	0.00	0.00
U	ULTRA DIA	0.00	0.00	0.00
U	ULTRA HEAD	0.00	0.00	0.00
F	FILLET DIA	0.00	0.00	0.00
F	FILLET HEAD	0.00	0.00	0.00
Q	OD BALL DIA	20.00	20.00	20.00
Q	NRTC BALL DIA	8.00	8.00	8.00
Q	PITCH DIA BALL DIA	20.00	20.00	20.00
Q	LP3C BALL DIA	22.00	22.00	22.00
Q	CONTACT DIA BALL DIA	20.00	20.00	20.00
EO	RUN OUT	0.00	0.00	0.00
EO	TOOTH THICKNESS	0.00	0.00	0.00
EO	CONTACT DIA BALL DIA	0.00	0.00	0.00
EO	LEAD	0.00	0.00	0.00
EO	BEAR BALL DIA	20.00	20.00	20.00
EO	BEAR BALL DIA	20.00	20.00	20.00
EO	BEAR BALL DIA	20.00	20.00	20.00
EO	BEAR BALL DIA	20.00	20.00	20.00

**ORIGINAL PAGE IS
POOR QUALITY**

SEE DIMENSIONAL CHART FOR MORE

**CLASS A (OTW) REDUCTION GEAR
Gear Layout**

Figure 4-2

TABLE 4-3

CLASS A (OTW) REDUCTION GEAR CHARACTERISTICS
AND 100% POWER, 100% SPEED DATA

	NON-DIMENSIONAL	SI UNITS	ENGLISH UNITS
RATIO	2.062		
TURBINE POWER		12813 kw	17183 hp
TURBINE SPEED		833.8 rad/s	7962 rpm
NO. OF STARS			8
GEAR PITCH LINE VELOCITY		119.3 m/s	23488 ft/min
STAR SPEED		1570.6 rad/s	14998 rpm
BEARING LOAD		26845 N	6035 lbs
NO. OF STARS	8		
SUN GEAR TEETH	81		
STAR GEAR TEETH	43		
RING GEAR TEETH	167		
HUNTING	YES		
NON-FACTORIZING	YES		

TABLE 4-4a

CLASS A (OTW) REDUCTION GEAR

GEAR DATA (SI UNITS)

	SUN GEAR	STAR GEAR	RING GEAR
NO. OF TEETH	81	43	167
MODULE	3.5335	3.5335	3.5335
PRESSURE ANGLE, DEGREES	21	21	21
PITCH DIAMETER, mm	286.2110	151.9392	590.0895
CENTER DISTANCE, mm		219.1	219.1
BASE DIA., mm	267.2011	141.8476	550.8960
TOOTH THICK (PD), mm	5.375	5.725	5.375
BACKLASH, mm	.102-.152	.102-.152	.127-.203
ROOT RAD., mm	1.12 (MIN)	1.37 (MIN)	.864 (MIN)
CONTACT RATIO (MIN) (NO BREAK EDGES)		2.18445	2.18327
CONTACT RATIO (MIN) (MAX. BREAK EDGES)		2.07490	2.05664
GEAR FACE WIDTH - mm	37.6	42.7	37.6
BENDING STRESS, N/cm ²	23,818	21,509	
		21,726	18,537
CONTACT STRESS, N/cm ²	88,139	88,139	
		61,383	61,383
MATERIAL	AMS6265 (SAE9310)	AMS6265 (SAE9310)	AMS6470
PROFILE CORRECTION	Fig. 4-3	Fig. 4-4	Fig. 4-5

TABLE 4-4b

CLASS A (OTW) REDUCTION GEAR

GEAR DATA (ENGLISH UNITS)

	SUN GEAR	STAR GEAR	RING GEAR
NO. OF TEETH	81	43	167
DIAMETRAL PITCH	7.1884	7.1884	7.1884
PRESSURE ANGLE, DEGREES	21	21	21
PITCH DIAMETER, IN.	11.26815	5.98186	23.23187
CENTER DISTANCE, IN		8.625	8.625
BASE DIA., IN.	10.51973	5.58455	21.68882
TOOTH THICK (PD), IN.	.21163	.22540	.21164
BACKLASH, IN.	.004-.006	.004-.006	.005-.008
ROOT RAD., IN.	.044 (MIN)	.054 (MIN)	.034 (MIN)
CONTACT RATIO (MIN) NO BREAK EDGES		2.18445	2.18327
CONTACT RATIO (MIN) (.010 MAX. BREAK EDGES)		2.07490	2.05664
GEAR FACE WIDTH - IN.	1.48	1.68	1.48
BENDING STRESS, PSI	34,545	31,196	
		31,511	26,886
CONTACT STRESS, PSI	127,835	127,835	
		89,029	89,029
MATERIAL	AMS6265 (SAE9310)	AMS6265 (SAE9310)	AMS6470
PROFILE CORRECTION	Fig. 4-3	Fig. 4-4	Fig. 4-5

ORIGINAL PAGE IS
OF POOR QUALITY

CLASS A (OTW) REDUCTION GEAR
SUN GEAR
INVOLUTE PROFILE MODIFICATION

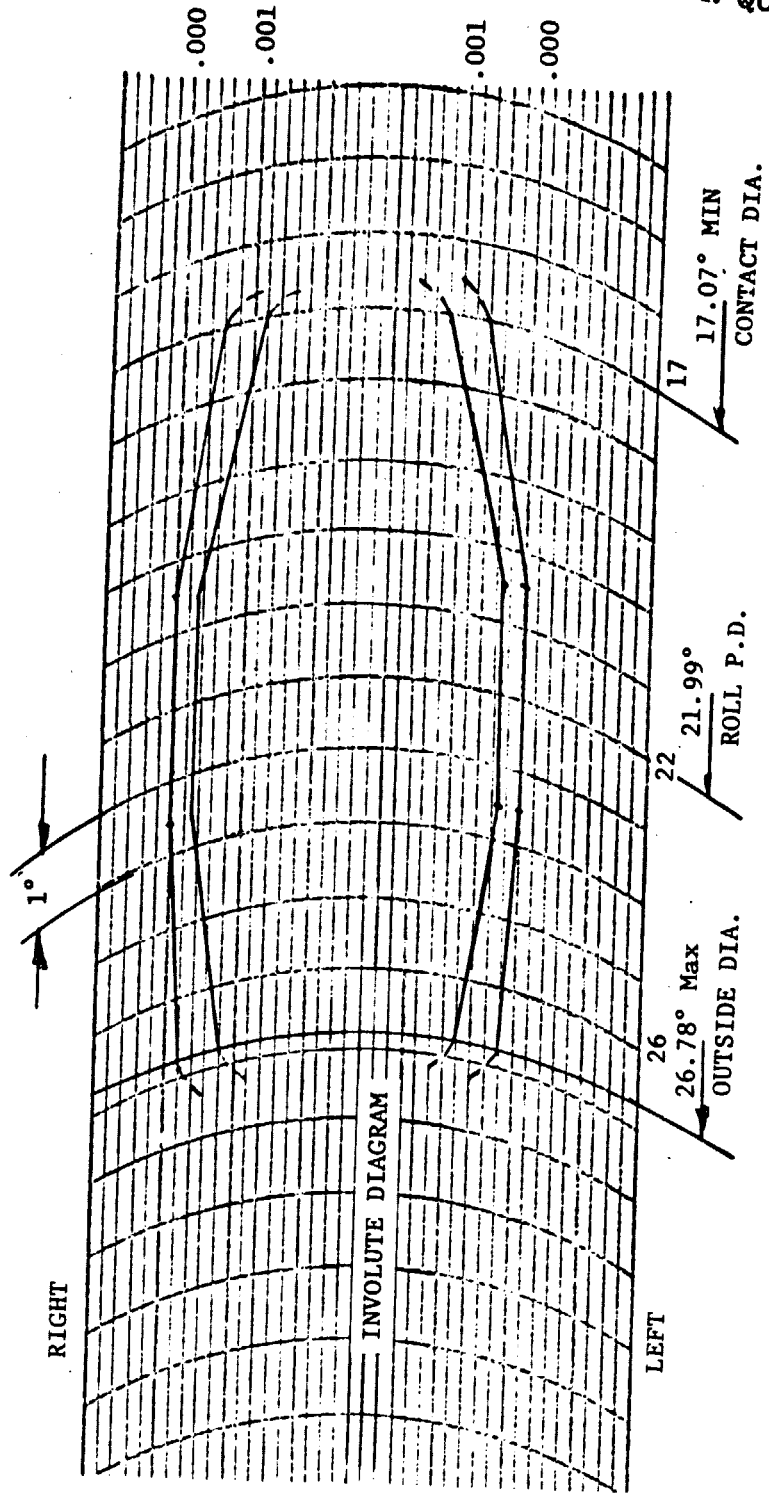

Figure 4-3

CLASS A (OTW) REDUCTION GEAR
STAR GEAR
INVOLUTE PROFILE MODIFICATION

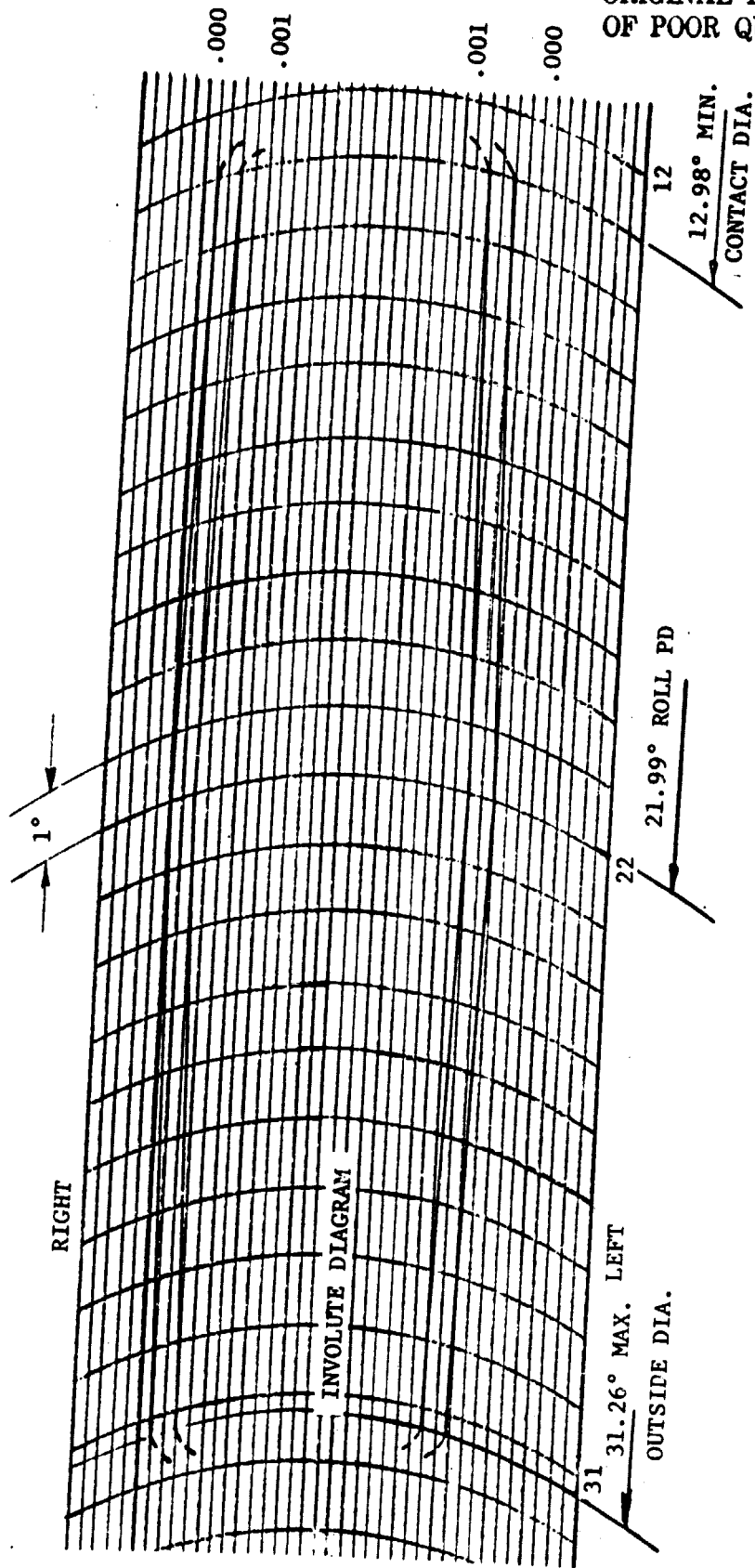

Figure 4-4

CLASS A (OTW) REDUCTION GEAR
RING GEAR
INVOLUTE PROFILE MODIFICATION

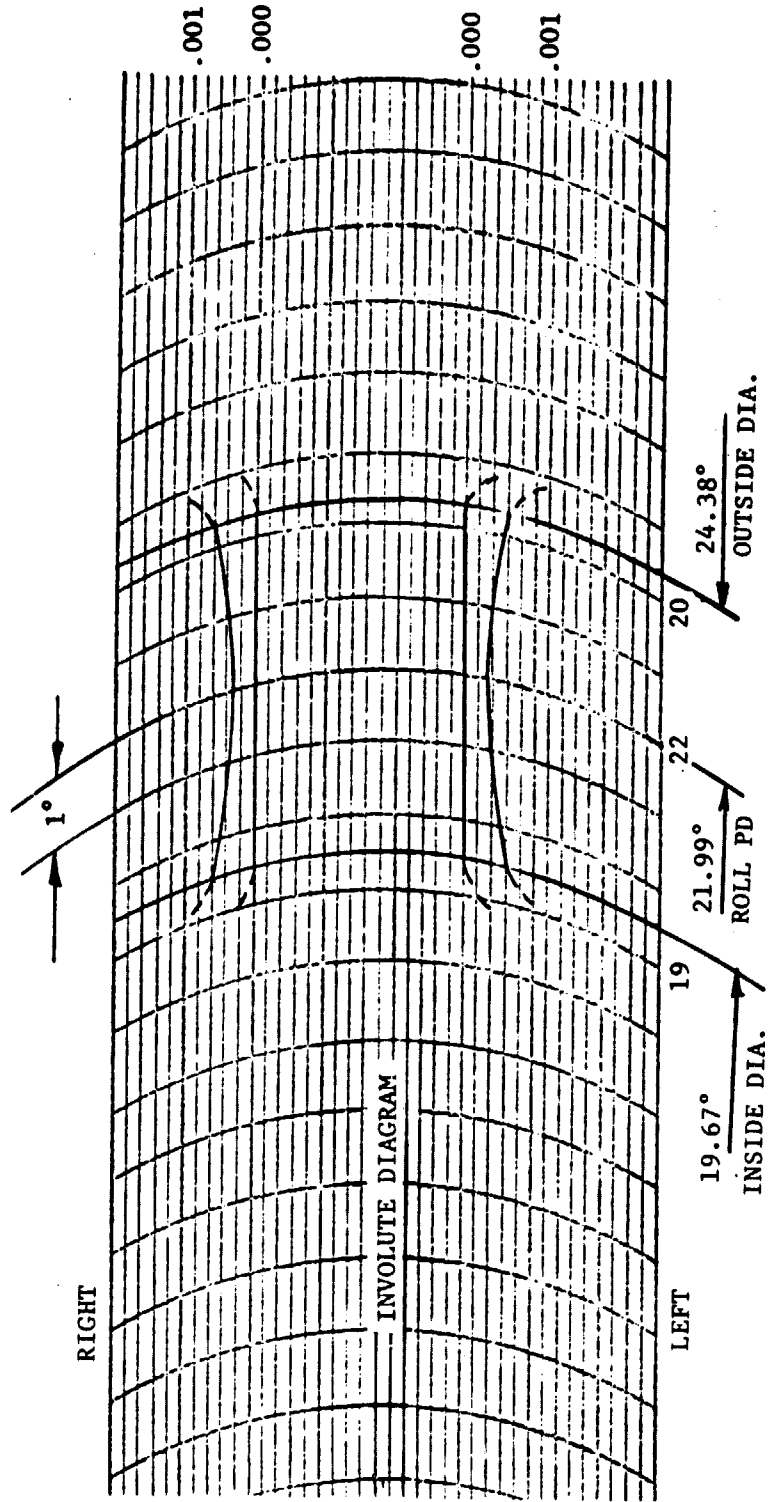

Figure 4-5

TABLE 4-5

CLASS A (OTW) REDUCTION GEAR

GEAR STRESS DATA

EXPERIMENTAL ENGINE TEST OPERATION

(SI UNITS)

TURBINE SPEED rad/s	TURBINE POWER kW	BENDING STRESS-N/cm ²			CONTACT STRESS-N/cm ²	
		SUN	STAR	RING	SUN/STAR	STAR/RING
875.5	12,813					
833.8	17,939	33,345	30,112	25,952	104,287	72,630
833.8	16,657	30,962	27,960	24,097	100,371	69,987
833.8	14,094	26,199	23,659	20,390	92,439	64,378
833.8	12,813	23,818	21,726	18,537	88,139	61,383
750.4	10,250					
625.4	6,407					
250.2	1,281					

(ENGLISH UNITS)

TURBINE SPEED RPM	TURBINE POWER HP	BENDING STRESS - PSI			CONTACT STRESS - PSI	
		SUN	STAR	RING	SUN/STAR	STAR/RING
8,360	17,183					
7,962	24,056	48,363	43,674	37,640	151,256	105,341
7,962	22,337	44,907	40,553	34,950	145,576	101,507
7,962	18,901	37,998	34,314	29,573	134,071	93,372
7,962	17,183	34,545	31,511	26,886	127,835	89,029
7,166	13,746					
5,972	8,592					
2,389	1,718					

N/cm^2 (151,256 psi) occurring in the sun to star gear mesh is only slightly greater than the allowable of $102,566 N/cm^2$ (148,760 psi) shown in Table 2-8 and, considering the small number of cycles is acceptable. The maximum ring gear stresses are well below the AGMA allowables.

The star gear bearing is a double row spherical roller type with cage guided symmetrical rollers. The bearing outer race is integral with the star gear. Lubrication of the bearing is through radial passages in the center of the inner race. Detailed data for the bearing are shown in Table 4-6. The bearing calculated mean load, mean speed and resultant B_1 fatigue life of 5063 hours for the flight spectrum (Table 4-1) and 4020 hours for the experimental engine operation schedule (Table 4-2) are shown in Table 4-7. The life values are based on the standard AFBMA life calculation method for roller bearings with a multiplying factor of 0.23 applied to convert from B_{10} to B_1 life and a factor of 5 applied for material, operating environment and oil jet lubrication. A section through the bearing which also shows the oil passages appears in Figure 4-1.

Oil flows for the reduction gears and bearings for the flight duty cycle are presented in Table 4-8. These flows are based on a variable oil pressure which is a function of core engine speed. The estimated effective oil supply pressures, temperatures and available flows at the reduction gear inlet for several engine operating conditions as supplied by General Electric are shown in Table 4-9. Maximum limit for the bearing outer race temperature has been established at $422^\circ K$ ($300^\circ F$). Calculated bearing outer race maximum temperature occurs during the cruise condition in the flight cycle. Required oil flow together with the effective oil pressure at this flight condition governs the bearing oil flow control orifice size. The controlling flight condition for oil flow to the gears based on gear scoring criteria is take-off. The orifice sizes in the gear spray bars are based on this requirement. Oil inlet temperatures shown in Table 4-8 and 4-9 are the result of General Electric heat balance iterations for the reduction gear and the engine.

Table 4-10 tabulates the overall OTW reduction gear efficiency for the flight duty cycle. Losses considered in calculating the efficiency are the spherical bearing loss, gear mesh loss and windage and churning losses. At

TABLE 4-6

CLASS A (OTW) REDUCTION GEAR
BEARING DATA

VENDOR, PART NO.	SKF 22312 VAM
TYPE	DOUBLE ROW SPHERICAL ROLLER (SPECIAL)
NO. OF ROLLERS (PER ROW)	14
SIZE OF ROLLERS	18 mm X 17.64 mm
DYNAMIC CAPACITY, "C"	202,400 N (45,500 LBS)
MATERIALS:	
OUTER RING (INTEGRAL WITH GEAR)	CARBURIZED ASM6265, Rc 60-63
INNER RING	CVM M-50 STEEL, Rc 60 MIN.
ROLLERS	CVM M-50 STEEL, Rc 60 MIN.
CAGE	AMS 4616, SILVER PLATED

TABLE 4-7

CLASS A (OTW) REDUCTION GEAR
BEARING LIFE DATA

<u>FLIGHT CYCLE</u>		
MEAN LOAD (10/3 EXP.)	18326 N	(4,120 lbs)
MEAN SPEED	1189.3 rad/s	(11,357 rpm)
B-1 LIFE	5063 hrs	
<u>EXPERIMENTAL ENGINE CYCLE</u>		
MEAN LOAD (10/3 EXP)	20781 N	(4,672 lbs)
MEAN SPEED	985 rad/s	(9,406 rpm)
B-1 LIFE	4020 hrs	

TABLE 4-8

CLASS A (OTW) REDUCTION GEAR

TOTAL OIL FLOWS

FLIGHT CYCLE

(SI UNITS)

CONDITION	TOTAL STAR BRG. FLOW, cm ³ /s	FLOW TO GEARS (SPRAY BARS), cm ³ /s	TOTAL OIL FLOW, cm ³ /s	OIL IN °K	BRG OUTER RACE TEMP °K
IDLE	381	630	1011	339	377
TO	639	1208	1847	353	413
CLIMB	626	1172	1798	353	408
CRUISE	622	1154	1776	375	422
DESCENT	512	955	1467	396	406
APPROACH	586	1119	1705	353	398
REVERSE	639	1208	1847	353	413
IDLE	381	630	1011	339	219

(ENGLISH UNITS)

CONDITION	TOTAL STAR BRG. FLOW, GAL/MIN	FLOW TO GEARS (SPRAY BARS), GAL/MIN	TOTAL OIL FLOW, GAL/MIN	OIL IN °F	BRG OUTER RACE TEMP °F
IDLE	6.04	9.99	16.03	150	219
TO	10.13	19.14*	29.27	180	283
CLIMB	9.92	18.58	28.50	180	275
CRUISE	9.87*	18.29	28.16	216	300
DESCENT	8.12	15.14	23.26	254	271
APPROACH	9.29	17.73	27.02	180	257
REVERSE	10.13	19.14	29.27	180	283
IDLE	6.04	9.99	16.03	150	219

* CONTROLLING CONDITION

TABLE 4-9
CLASS A (OTW) REDUCTION GEAR

OIL SUPPLY DATA
(SI UNITS)

CONDITION	MAX. OIL TEMP. - °K	AVAILABLE OIL FLOW - cm ³ /s	OIL PRESSURE N/cm ²
IDLE	339	1243	9.0
TAKE-OFF	353	2208	27.6
CLIMB	353	2145	26.2
CRUISE	375	2044	23.4
DESCENT	396	1640	15.2
APPROACH	353	2019	22.8
REVERSE	353	2208	27.6

(ENGLISH UNITS)

CONDITION	MAX. OIL TEMP - °F	AVAILABLE OIL FLOW - GPM	OIL PRESSURE PSI
IDLE	150	19.7	13
TAKEOFF	180	35.0	40
CLIMB	180	34.0	38
CRUISE	216	32.4	34
DESCENT	254	26.0	22
APPROACH	180	32.0	33
REVERSE	180	35.0	40

TABLE 4-10

CLASS A (OTW) REDUCTION GEAR
OVERALL REDUCTION GEAR EFFICIENCY
FLIGHT CYCLE
(SI UNITS)

CONDITION	POWER LOSS - kW				OVERALL EFFICIENCY %
	SPHERICAL BRG	GEAR MESH	CHURN & WINDAGE	TOTAL	
IDLE	11.46	4.62	1.52	17.60	98.63
TO	26.32	49.97	37.72	114.01	99.11*
CLIMB	23.85	39.48	27.34	90.67	99.10
CRUISE	20.60	28.49	18.94	68.03	99.07
DESCENT	3.46	1.84	0.13	5.43	98.73
APPROACH	18.31	26.99	13.77	59.07	99.15
REVERSE	26.32	49.97	37.72	114.01	99.11
IDLE	11.46	4.62	1.52	17.60	98.63
* SPEC 99.20%					

(ENGLISH UNITS)

CONDITION	POWER LOSS - HP				OVERALL EFFICIENCY %
	SPHERICAL BRG	GEAR MESH	CHURN & WINDAGE	TOTAL	
IDLE	15.37	6.19	2.04	23.60	98.63
TO	35.30	67.01	50.59	152.90	99.11*
CLIMP	31.98	52.94	36.66	121.58	99.10
CRUISE	27.62	38.20	25.40	91.22	99.07
DESCENT	4.64	2.47	0.17	7.28	98.73
APPROACH	24.55	36.19	18.46	79.20	99.15
REVERSE	35.30	67.01	50.59	152.90	99.11
IDLE	15.37	6.19	2.04	23.60	98.63
* SPEC 99.20%					

take-off conditions the calculated overall efficiency is 99.11 percent. This is slightly below the M50TF1611 specification objective of 99.20 percent for the 100 percent speed and 100 percent power operating condition.

Total heat rejection for the flight duty cycle, delta rise in bulk oil temperature, and the temperature of the bulk oil resulting with the oil inlet supply temperatures (shown in Table 4-9) are presented in Table 4-11. Table 4-12 tabulates the AGMA scoring index and Table 4-13 tabulates the Curtiss-Wright scoring index for each flight duty cycle operating condition. The two approaches to scoring index calculation and evaluation were discussed in Section 2.2. Based on Curtiss-Wright experience, the maximum scoring index (AGMA 295°F C-W 306°F) shown for the cruise part of the flight cycle is acceptable.

The Curtiss-Wright approach to the controlled deflection of the gear components under load to insure uniform loading across the face width of all mating gears discussed in Section 2.2 is carried into the OTW reduction gear detailed design. Gear and support section moduli were selected that provide relatively close gear and tooth deflection compatibility at each gear mesh. The calculated deflections are discussed in detail in Section 4.3.

Calculated OTW gear tooth load line operating positions relative to the star gear pitch line for the ring-to-star and sun-to-star meshes are shown in Figure 4-6. The displacements are the summation of deflections resulting from the operating centrifugal forces, gear tooth radial separating forces and tangential gear tooth loads. The difference in displacements over the length of the teeth results in the slopes of the load line relative to the axis of the gear of 0.000831 and 0.000848 for the ring and sun gear meshes, respectively. Since the star gear is supported by a spherical bearing, it is free to seek a balanced moment load position, a rotation of 0.012 mm (0.00048 inches) relative to the plane of the inner race, measured at the star gear pitch line. The star gear carrier support trunnion or post deflects under load in the direction that favors the alignment between the star gear and the bearing inner race. Taking the trunnion deflection into consideration the star gear operating axis and the fixed carrier support trunnion axis at 100% power and 100% speed coincide within 0.0012 mm (0.00005 inches), the difference between the support deflected position and the gear tooth position shown

TABLE 4-11

CLASS A (OTW) REDUCTION GEAR

HEAT REJECTION

FLIGHT CYCLE
(SI UNITS)

CONDITION	TOTAL LOSS kW	DELTA RISE IN BULK OIL TEMP °K	OIL IN TEMP °K	BULK OIL TEMP °K
IDLE	17.60	8.63	339	348
TO	114.00	31.20	355	386
CLIMB	90.62	25.47	355	381
CRUISE	68.01	19.85	375	395
DESCENT	5.43	1.97	397	399
APPROACH	59.04	17.51	355	373
REVERSE	114.00	31.20	355	386
IDLE	17.60	8.63	339	348

(ENGLISH UNITS)

CONDITION	TOTAL LOSS BTU/MIN	DELTA RISE IN BULK OIL TEMP °F	OIL IN TEMP °F	BULK OIL TEMP °F
IDLE	1001	15.53	150	166
TO	6486	56.15	180	236
CLIMB	5157	45.85	180	226
CRUISE	3870	35.73	216	252
DESCENT	309	3.54	254	258
APPROACH	3360	31.51	180	212
REVERSE	6486	56.15	180	236
IDLE	1001	15.53	150	166

TABLE 4-12

CLASS A (OTW) REDUCTION GEAR

AGMA SCORING INDEX

FLIGHT CYCLE

CONDITION	OIL IN TEMP °F	AGMA ΔT °F	AGMA SCORING INDEX °F
IDLE	150	23.17	173
TO	180	117.88	298
CLIMB	180	100.03	280
CRUISE	216	78.53	295
DESCENT	254	11.97	266
APPROACH	180	78.02	258
REVERSE	180	117.88	298
IDLE	150	23.17	173

TABLE 4-13

CLASS A (OTW) REDUCTION GEAR

CURTISS-WRIGHT SCORING INDEX

FLIGHT CYCLE

CONDITION	OIL IN TEMP °F	C-W SCORING INDEX - °F	
		RING-STAR MESH	SUN-STAR MESH
IDLE	150	163	174
TO	180	251	314
CLIMB	180	240	293
CRUISE	216	263	306
DESCENT	254	262	269
APPROACH	180	227	270
REVERSE	180	251	314
IDLE	150	163	174

CLASS A (OTW) REDUCTION GEAR
STAR GEAR DEFLECTION

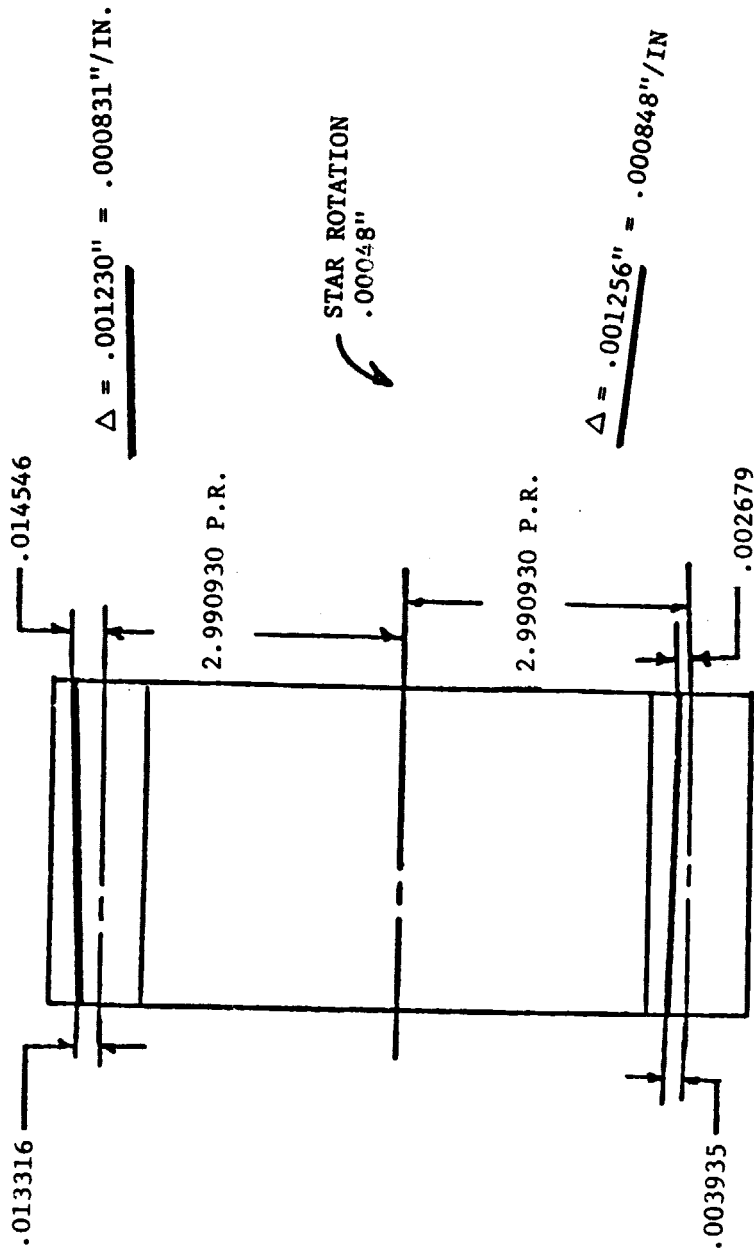

SUPPORTS OF SUN GEAR & RING GEAR ARE ON THE LEFT HAND
(FORWARD) SIDES, OPPOSITE THAT OF STAR GEAR TRUNNION.

Figure 4-6

in Figure 4-7. This very small amount of misalignment between the planes of the star gear and the star gear bearing inner race is readily accommodated by the spherical roller bearing.

Table 4-14 tabulates the summary of the weight analysis. The calculated OTW unit installed weight as supplied by Curtiss-Wright is 89.89 kg (198.18 pounds). The detailed weight breakdown by parts is given in Appendix D.

Table 4-15 tabulates weight reduction items to be considered for a production type reduction gear and these features would save a calculated 6.58 kg (14.52 pounds) and result in a future weight of 83.31 kg (183.66 pounds) for the OTW gear assembly. Further reduction in weight is possible with additional development effort directed toward a specific operating requirement.

4.2 Stress Analysis

AGMA gear stresses are presented in the preceding discussion and data. Additional stress analyses and evaluations for the gears and carrier support are discussed in detail in this section of the report. Stress analysis of the coupling is discussed in Section 3.2.6 of this report since the part is common to both the OTW and UTW units.

4.2.1 Gear Tooth Bending Stress

Maximum gear tooth bending stress for the OTW reduction gearing is less than that for the UTW design. Figures 4-8 and 4-9 show the Goodman diagrams for the gear tooth bending stresses along with AGMA allowable curves and the Curtiss-Wright experience curve. Although the star gear at the 140% torque condition exceeds the AGMA allowable by 13%, it is well below the C-W experience allowable.

4.2.2 Backing Stresses

Sun Gear - The backing stresses on the sun gear are tabulated on Table 4-16 for design conditions and Table 4-17 for the 140% torque condition. Figure 4-10 shows a cross-section of the sun gear and identifies the points of maximum stress. In general, the stresses are slightly higher for the OTW unit but the Goodman diagram shown in Figure 4-11 shows vibratory margins well over 5.0.

CLASS A (OTW) REDUCTION GEAR
CONTROLLED GEAR DEFLECTIONS

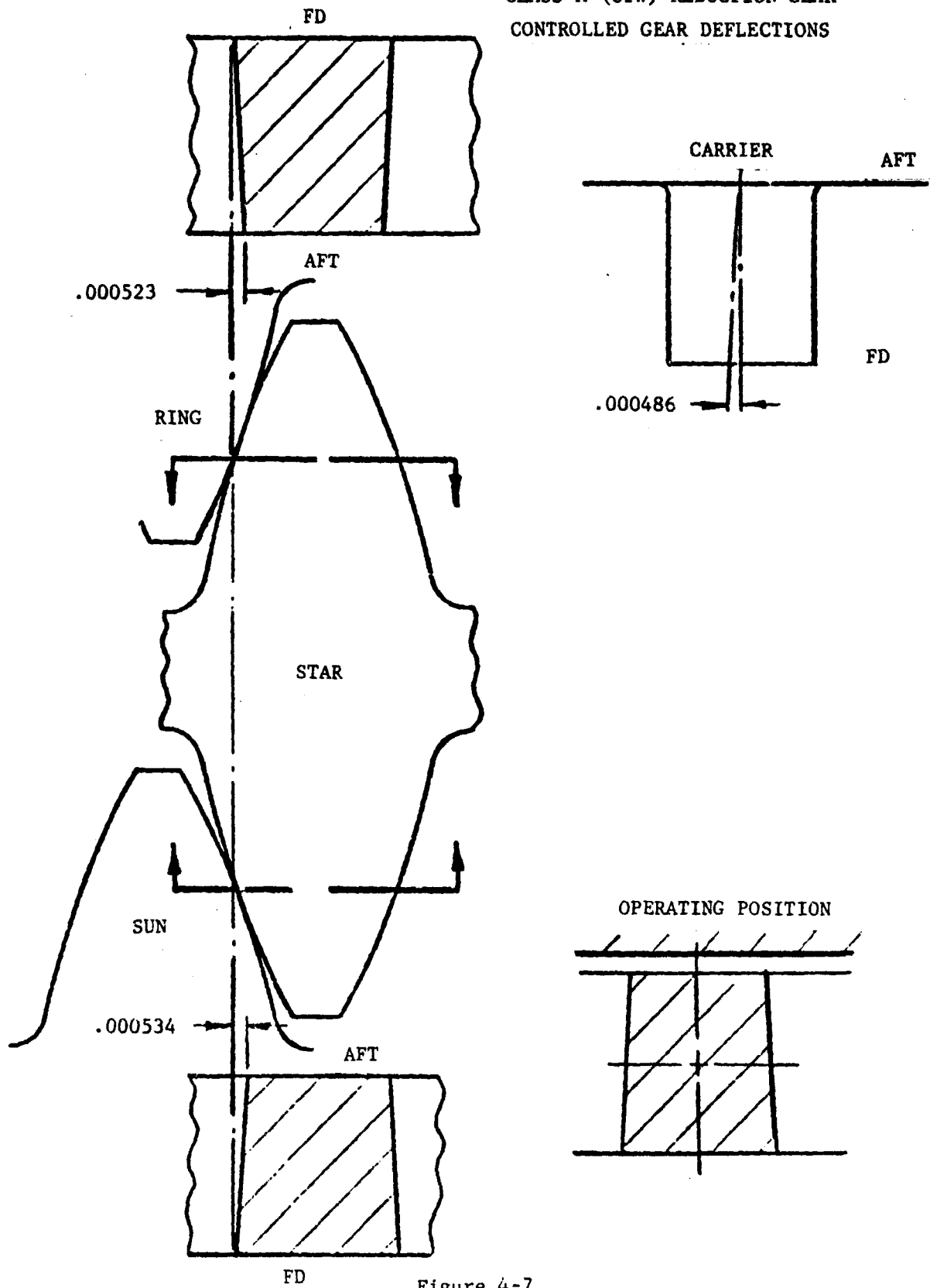

Figure 4-7

TABLE 4-14

CLASS A (OTW) REDUCTION GEAR

WEIGHT SUMMARY

	BASIC MATERIAL	KILOGRAMS	POUNDS
SUN GEAR ASSEMBLY	STEEL	11.29	24.89
RING GEAR	STEEL	12.42	27.38
STAR NUTS	STEEL	2.08	4.58
CARRIER SUPPORT	STEEL	23.02	50.75
STARS	STEEL	37.26	82.14
STARWASHER	STEEL	.14	.31
MANIFOLD	ALUMINUM	1.80	3.97
SPRAY BARS	STEEL	.28	.61
MISCELLANEOUS HARDWARE		1.61	3.55
TOTAL		89.89	198.18

TABLE 4-15

CLASS A (OTW) REDUCTION GEAR

FLIGHT UNIT WEIGHT REDUCTION

(1) Integrate star gear carrier support and G.E. reduction gear support from fan frame to eliminate interface flange, bolts and nuts.		
(2) Make carrier support of titanium.		
Resulting system weight reduction:		
	kg	lbs
FLANGE	1.27	2.81
BOLTS AND NUTS	.57	1.26
SUPPORT MATERIAL	4.74	10.45
TOTAL	6.58	14.52

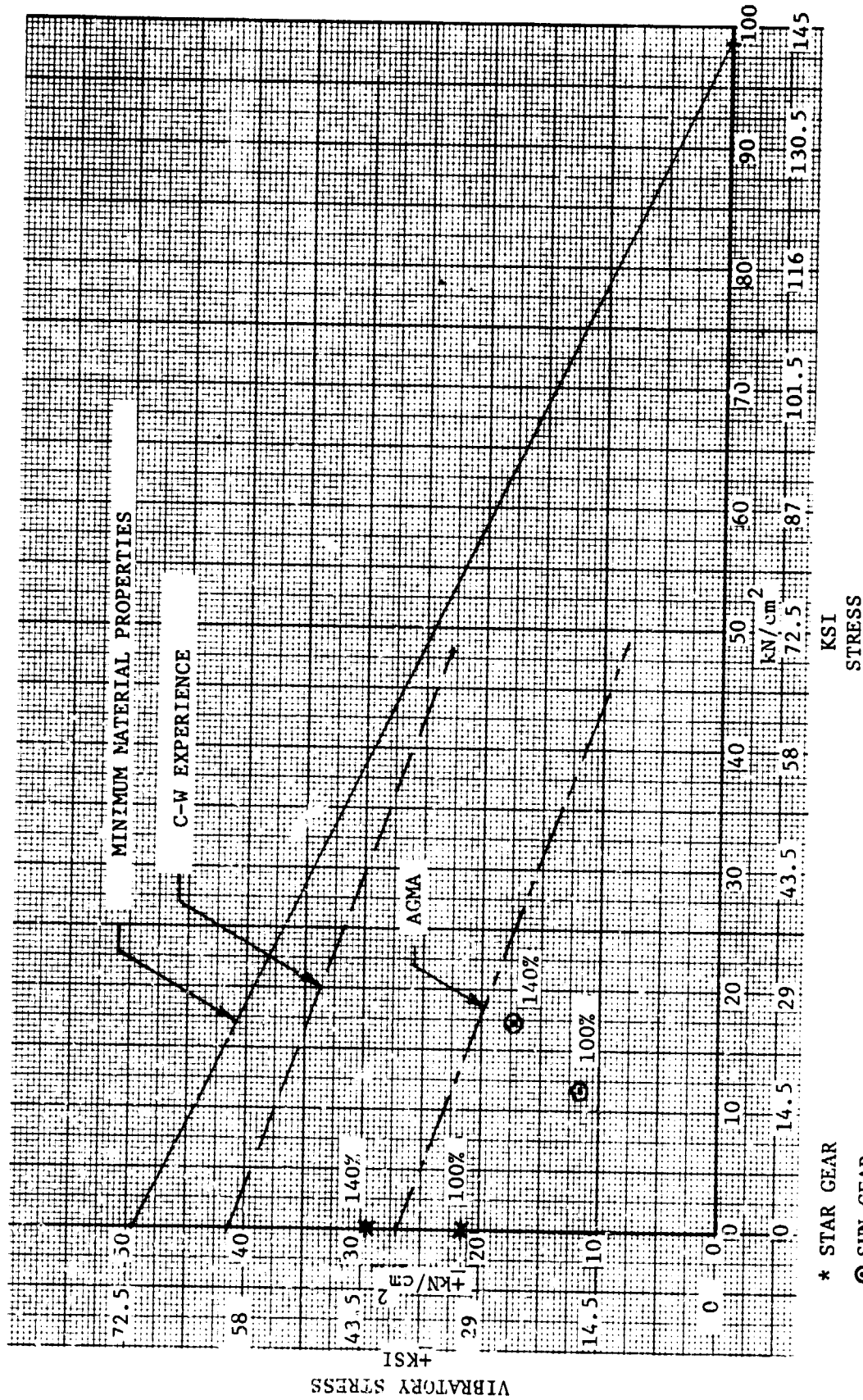

* STAR GEAR

⊙ SUN GEAR

MATERIAL - AMS 6265

Figure 4-8. Sun and Star Gear Tooth Bending Stress For 100% And 140% Torque Class A (OTW) Reduction Gear

ORIGINAL PAGE IS
OF POOR QUALITY

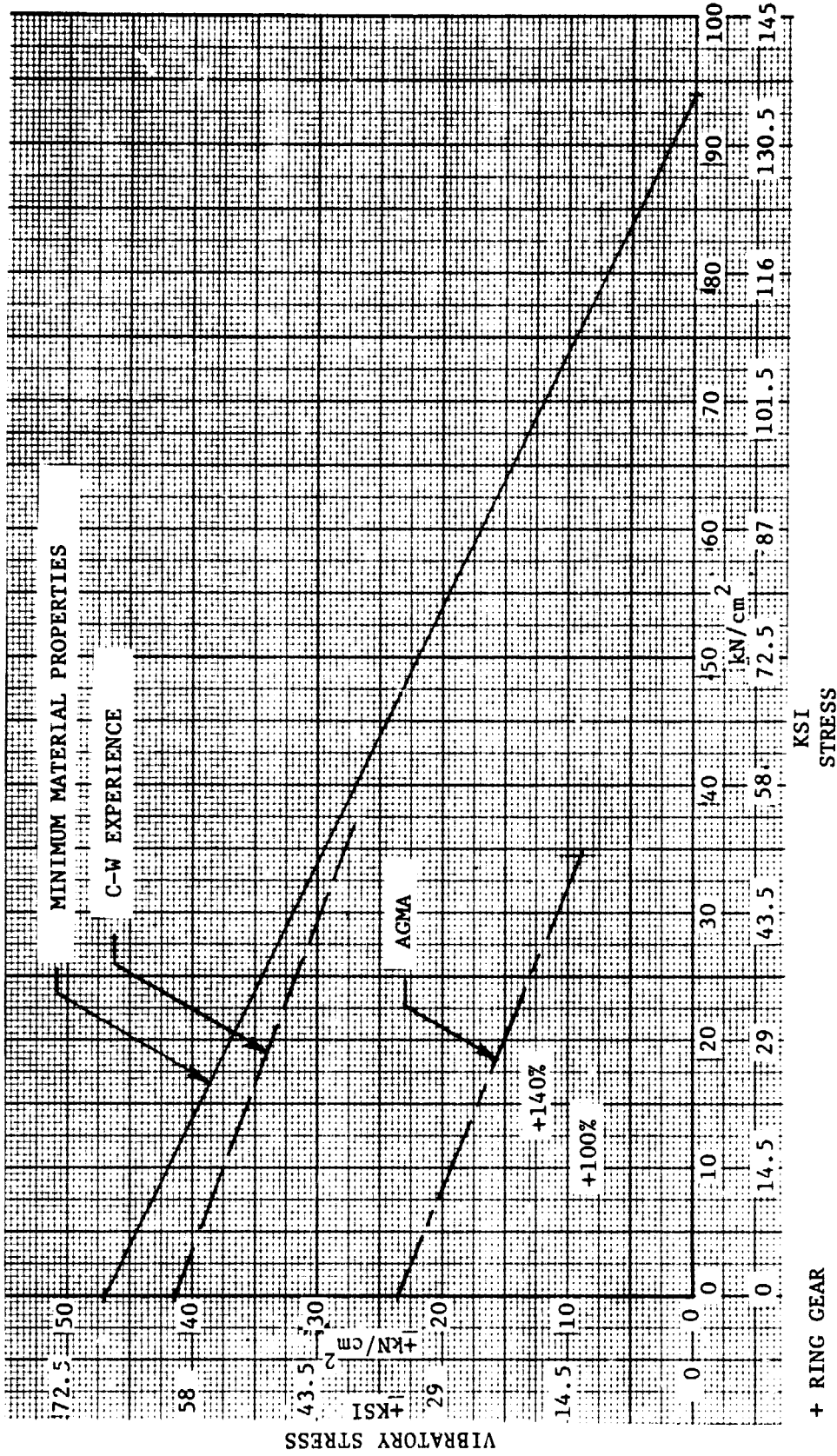

+ RING GEAR
MATERIAL - AMS 6470

Figure 4-9. Ring Gear Tooth Bending Stress For 100% And 140% Torque
Class A (OTW) Reduction Gear.

TABLE 4-16a
 CLASS A (OTW) REDUCTION GEAR
 SUN GEAR BACKING STRESSES (N/cm²) (SI UNITS)
 100% SPEED (834 RAD/S); 100% TORQUE (15,369 N-M)

Stress Area Fig. 4-10	Load	Circumferential Stress			Longitudinal	Shear	Equivalent
		At Star Gear		Between Star Gears			
		Front	Back				
1	Rad	- 4,905	- 4,905	+ 532			
	Tang	+ 4,694	- 4,694	-			
	Centri	+13,344	+13,344	+13,344			+10,078
	T.M.	+ 1,267	+ 1,267	+ 1,267			± 5,066
	Total	+14,387	+ 5,012	+15,143			
2	Rad	+ 2,952	+ 2,952	- 3,426	-	-	
	Tang	- 5,321	+ 5,321	-	-	+ 1,068	
	Centri	+13,344	+13,344	+13,344	-	-	+16,565
	T.M.	+ 678	+ 678	+ 678	-	-	± 5,807
	Total	+11,653	+22,295	+10,597		+ 1,068	
3	Rad	+ 2,952	+ 2,952	- 3,426			
	Tang	- 5,321	+ 5,321	-		+ 5,242	
	Centri	+13,344	+13,344	+13,344	- 5,641		+21,803
	T.M.	+ 407	+ 407	+ 407			± 5,097
	Total	+11,382	+22,025	+10,326	- 5,641	+ 5,242	
5	Tang	+ 5,303	+ 5,303	+ 5,303	+ 4,495	+10,766	+19,293
6	Tang	+ 6,415	+ 6,415	+ 6,415	- 1,959	+10,766	+20,132

Abbreviations:

Radial - Rad	Centrifugal - Centri
Tangential - Tang	Toroidal Moment - T.M.

TABLE 4-16b

CLASS A (OTW) REDUCTION GEAR

SUN GEAR BACKING STRESSES (PSI) (ENGLISH UNITS)

100% SPEED (7962 RPM); 100% TORQUE (136,029 IN-LB)

Stress Area Fig. 4-10	Load	Circumferential Stress			Longitudinal	Shear	Equivalent
		At Star Gear		Between Star Gears			
		Front	Back				
1	Rad	- 7,114	- 7,114	+ 772			
	Tang	+ 6,808	- 6,808	-			
	Centri	+19,354	+19,354	+19,354			+14,617
	T.M.	+ 1,838	+ 1,838	+ 1,838			+ 7,347
	Total	+20,866	+ 7,270	+21,964			
2	Rad	+ 4,281	+ 4,281	- 4,969	-	-	
	Tang	- 7,718	+ 7,718	-	-	+ 1,549	
	Centri	+19,354	+19,354	+19,354	-	-	+24,025
	T.M.	+ 984	+ 984	+ 984	-	-	+ 8,423
	Total	+16,901	+32,337	+15,369		+ 1,549	
3	Rad	+ 4,281	+ 4,281	- 4,969			
	Tang	- 7,718	+ 7,718	-		+ 7,603	
	Centri	+19,354	+19,354	+19,354	- 8,182		+31,623
	T.M.	+ 591	+ 591	+ 591			+ 7,392
	Total	+16,508	+31,944	+14,976	- 8,182	+ 7,603	
5	Tang	+ 7,692	+ 7,692	+ 7,692	+ 6,520	+15,615	+27,982
6	Tang	+ 9,304	+ 9,304	+ 9,304	- 2,841	+15,615	+29,199
Abbreviations: Radial - Rad Centrifugal - Centri Tangential - Tang Toroidal Moment - T.M.							

TABLE 4-17a

CLASS A (OTW) REDUCTION GEAR

SUN GEAR BACKING STRESSES (N/cm²) (SI UNITS)

100% SPEED (834 RAD/S); 140% TORQUE (21,517 N-M)

Stress Area Fig. 4-10	Load	Circumferential Stress			Longitudinal	Shear	Equivalent
		At Star Gear		Between Star Gears			
		Front	Back				
1	Rad	- 6,867	- 6,867	+ 745			
	Tang	+ 6,571	- 6,571	-			
	Centri	+13,344	+13,344	+13,344			+ 8,771
	T.M.	+ 1,744	+ 1,774	+ 1,774			+ 7,093
	Total	+14,822	+ 1,678	+15,863			
2	Rad	+ 4,132	+ 4,132	- 4,797	-	-	
	Tang	- 7,450	+ 7,450	-	-	+ 1,495	
	Centri	+13,344	+13,344	+13,344	-	-	+17,935
	T.M.	+ 950	+ 950	+ 950	-	-	+ 8,091
	Total	+10,976	+25,876	+ 9,498		+ 1,495	
3	Rad	+ 4,132	+ 4,132	- 4,797		-	
	Tang	- 7,450	+ 7,450	-		+ 7,339	
	Centri	+13,344	+13,344	+13,344	- 5,641	-	+24,765
	T.M.	+ 570	+ 570	+ 570		-	+ 6,667
	Total	+10,597	+25,496	+ 9,118	- 5,641	+ 7,339	
5	Tang	+ 7,425	+ 7,425	+ 7,425	+ 6,294	+15,073	27,010
6	Tang	+ 8,981	8,981	+ 8,981	- 2,742	+15,073	28,184
<p>Abbreviations:</p> <p>Radial - Rad Centrifugal - Centri</p> <p>Tangential - Tang Toroidal Moment - T.M.</p>							

TABLE 4-17b

CLASS A (OTW) REDUCTION GEAR

SUN GEAR BACKING STRESSES (PSI) (ENGLISH UNITS)

100% SPEED (7962 RPM); 140% TORQUE (190,441 IN-LB)

Stress Area Fig. 4-10	Load	Circumferential Stress			Longitudinal	Shear	Equivalent
		At Star Gear		Between Star Gears			
		Front	Back				
1	Rad	- 9,960	- 9,960	+ 1,080			
	Tang	+ 9,531	- 9,531	-			
	Centri	+19,354	+19,354	+19,354			+12,721
	T.M.	+ 2,573	+ 2,573	+ 2,573			+10,287
	Total	+21,498	+ 2,434	+23,007			
2	Rad	+ 5,993	+ 5,993	- 6,957	-	-	
	Tang	-10,805	+10,805	-	-	+ 2,168	
	Centri	+19,354	+19,354	+19,354	-	-	+26,012
	T.M.	+ 1,378	+ 1,378	+ 1,378	-	-	+11,735
	Total	+17,920	+37,530	+13,775		+ 2,168	
3	Rad	+ 5,993	+ 5,993	- 6,957		-	
	Tang	-10,805	+10,805	-		+10,644	
	Centri	+19,354	+19,354	+19,354	- 8,182	-	+35,919
	T.M.	+ 827	+ 827	+ 827		-	+ 9,663
	Total	+15,369	+36,979	+13,224	- 8,182	+10,644	
5	Tang	+10,769	+10,769	+10,769	+ 9,128	+21,861	39,175
6	Tang	+13,026	13,026	+13,026	- 3,977	+21,861	40,878

Abbreviations:
 Radial - Rad Centrifugal - Centri
 Tangential - Tang Toroidal Moment - T.M.

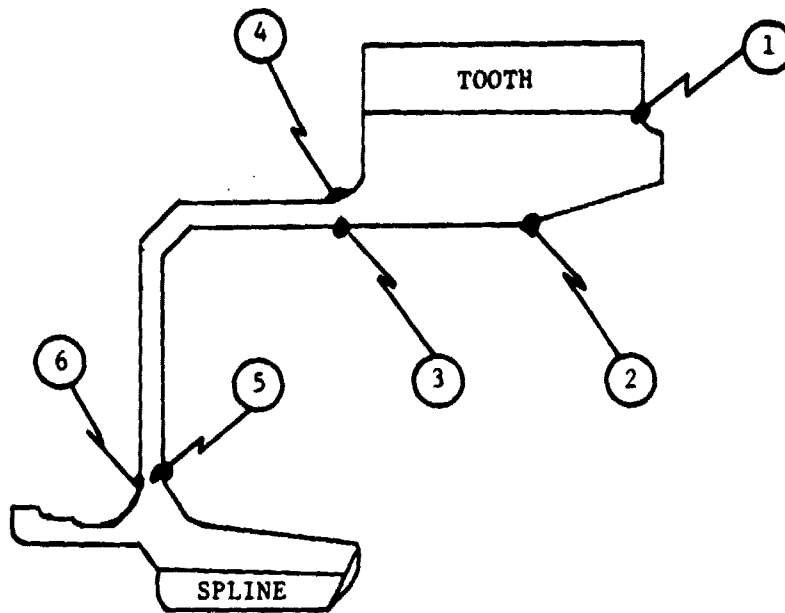

ENGINE

4

① NUMBERS IDENTIFY STRESS ANALYSIS AREAS, TABLES 4-16 AND 4-17

REFERENCE 100% SPEED AND LOAD DATA

DATA ITEM	DATA ITEM MAGNITUDE	
	ENGLISH UNITS	SI UNITS
100% SPEED	7,962 RPM	834 RAD/S
100% TORQUE	136,029 IN./LBS	15,369 N-M
TANGENTIAL LOAD	3,018 LBS/STAR	13,425 N/STAR
RADIAL LOAD	1,158 LBS/STAR	

Figure 4-10. Sun Gear High Stress Areas (Identification) For Tables 4-16 & 4-17) Class A (OTW) Reduction Gear.

ORIGINAL PAGE IS
OF POOR QUALITY

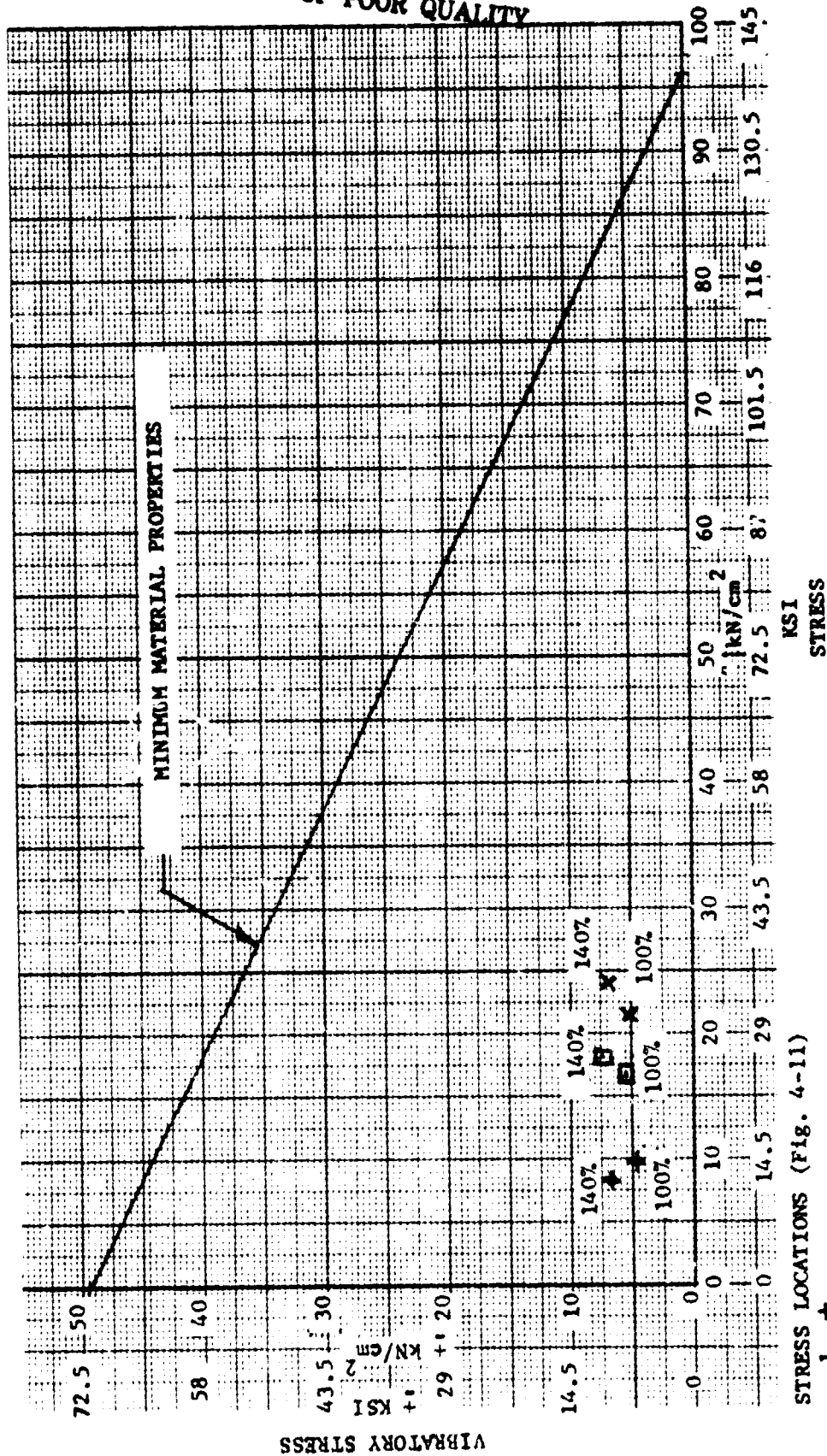

STRESS LOCATIONS (Fig. 4-11)

- 1 +
- 2 □
- 3 x

MATERIAL - ANS 6265

Figure 4-11. Sun Gear Backing Stress For 100% And 140% Torque
(No Stress Concentration Factors) Class A (OTW) Reduction Gear.

Ring Gear - Design speed of the ring gear is 23% higher for the OTW unit design than for the UTW unit and results in 57% higher centrifugal stresses. Table 4-18 shows the stress distribution in the ring gear. The stresses due to the radial forces are somewhat lower, resulting in higher mean stress but lower vibratory stresses. Figure 4-12 is a cross-section view of the ring gear with the points of high stress identified. The vibratory margins for the points where stress concentration factors would exist will be over 3.5 for the 100% torque and 2.9 for the 140% torque. Point 2, the outer surface of the rim, has a vibratory margin of 1.71 for the 140% torque operation which is considered satisfactory since there is no stress concentration factor at that point. The stress levels at 100% and 140% torque are shown on a Goodman Diagram, Figure 4-13, for the three points identified on Figure 4-12.

Star Gear - The star gear points of high stress are identified on Figure 4-14 and the detailed stress values are shown in Table 4-19. Since the speed of the star gear is 42% higher for the OTW design, the centrifugal stresses are also much higher. Torque is also higher, so that the radial and tangential loads cause higher stresses. The Goodman diagram for the star gear is shown on Figure 4-15. At point 2, the minimum diameter of the gear rim, for the 140% torque condition a 3.77 vibratory margin is obtained and is considered satisfactory.

4.2.3 "Combined" Stress

Sun Gear - Stress data used in calculating the "combined" stresses is described in the UTW unit discussion, Section 3.2.3. Table 4-20 shows the detailed stress values and Figure 4-16 shows the Goodman diagram for the AMS 6265 material. Vibratory margins are slightly smaller than those for the UTW design, being 1.36 for 100% design torque and 0.995 for 140% torque. Since the allowable curve for the material does not include the effect of shot peening, an additional 15% margin will exist. Considering the conservative technique used to estimate the "combined" stress, the sun gear is considered acceptable.

TABLE 4-18a
 CLASS A (OTW) REDUCTION GEAR
 RING GEAR BACKING STRESSES (N/cm²)(SI UNITS)
 100% SPEED (404 RAD/S)

Stress Area (Fig.4-12)	Load	Circumferential Stress			Longitudinal	Shear	Equivalent
		At Star Gear		Between Star Gears			
		Front	Back				
100% TORQUE (31,687 N-M)							
1,2,3 1	Centri	+16,750	+16,750	+16,750	-	-	
	Rad	- 9,454	- 9,454	+ 6,952			
	Tang	+ 5,404	- 5,404	-			+15,746
	T.M.	+ 2,635	+ 2,635	+ 2,635			+10,906
	Total	+15,335	+ 4,527	+26,007			
2	Rad	+13,947	+13,947	- 4,481			
	Tang	- 6,263	+ 6,269	-			
	T.M.	+ 1,173	+ 1,173	+ 1,173			+25,608
	Total	+25,601	+38,133	+13,083			+12,525
3	Rad	+ 3,406	+ 3,406	464	+ 276	-	
	Tang	- 1,011	+ 1,011	-		+ 2,765	
	T.M.	+ 2,346	+ 2,346	+ 2,346		-	+22,067
	Total	+21,491	+23,514	+19,560	+ 276	+ 2,765	+ 1,929

140% TORQUE - 44,362 N-M

1	Rad	-13,235	-13,235	+ 9,733			
	Tang	+ 7,566	- 7,566	-			+14,906
	T.M.	+ 3,689	+ 3,689	+ 3,689			+15,267
	Total	+14,770	- 361	+30,172			
2	Rad	+19,525	+19,525	- 6,727			
	Tang	- 8,777	+ 8,777	-			+29,843
	T.M.	+ 1,643	+1,643	+ 1,643			+16,853
	Total	+29,141	+46,695	+11,611			
3	Rad	+ 4,768	+ 4,768	+ 650	+ 276	-	
	Tang	- 1,416	+ 1,416	-		+ 3,871	
	T.M.	+ 3,285	+ 3,285				+26,033
	Total	+29,572	+26,214	+20,684	+ 276	+ 3,871	+ 4,289

Abbreviations:

Radial - Rad
 Tangential - Tang

Centrifugal - Centri
 Toroidal Moment - T.M.

TABLE 4-18b
 CLASS A (OTW) REDUCTION GEAR
 RING GEAR BACKING STRESSES (PSI)(ENGLISH UNITS)
 100% SPEED (3862 RPM)

Stress Area (Fig.4-12)	Load	Circumferential Stress			Longitudinal	Shear	Equivalent
		At Star Gear		Between Star Gears			
		Front	Back				
100% TORQUE (280,455 IN.-LB.)							
1,2,3	Centri	+24,294	+24,294	+24,294		-	
	Rad	-13,712	-13,712	+10,083			
	Tang	+ 7,838	- 7,838	-			+22,838
1	T.M.	+ 3,822	+ 3,822	+ 3,822			+15,817
	Total	+22,242	+ 6,566	+38,199			
2	Rad	+20,228	+20,228	- 7,021			
	Tang	- 9,083	+ 9,093	-			
	T.M.	+ 1,702	+ 1,702	+ 1,702			+37,141
2	Total	+37,131	+55,307	+18,975			+18,166
	Rad	+ 4,940	+ 4,940	673	+ 401	-	
3	Tang	- 1,467	+ 1,467	-	-	+ 4,010	
	T.M.	+ 3,403	+ 3,403	+ 3,403	-	-	+32,006
	Total	+31,170	\$34,104	+28,370	+ 401	+ 4,010	+ 2,798

140% TORQUE (392,637 IN.-LB.)

1	Rad	-19,196	-19,196	+14,116			
	Tang	+10,973	-10,973	-			+21,619
	T.M.	+ 5,351	+ 5,351	+ 5,351			+22,143
1	Total	+21,422	- 524	+43,761			
	Rad	+28,319	+28,319	- 9,829			
2	Tang	-12,730	+12,730	-			+43,283
	T.M.	+ 2,383	+ 2,383	+ 2,383			+24,443
	Total	+42,266	+67,726	+16,840			
2	Rad	+ 6,916	+ 6,916	+ 942	+ 401	-	
	Tang	- 2,054	+ 2,054	-		+ 5,614	
3	T.M.	+ 4,764	+ 4,764	+ 4,764			+37,757
	Total	+42,890	+38,020	+30,000	+ 401	+ 5,614	+ 6,221

Abbreviations:

Radial - Rad
 Tangential - Tang

Centrifugal - Centri
 Toroidal Moment - T.M.

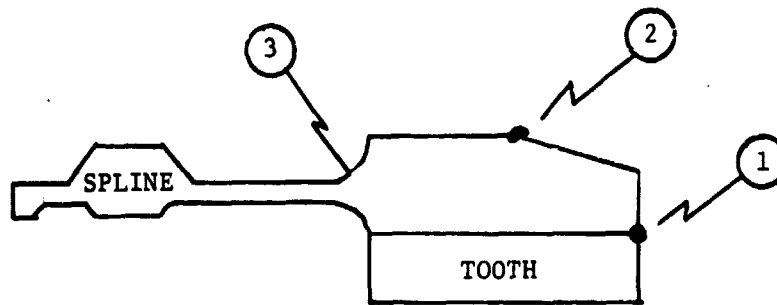

① NUMBERS IDENTIFY STRESS ANALYSIS AREAS, TABLE 4-18

REFERENCE 100% SPEED AND LOAD DATA

DATA ITEM	DATA ITEM MAGNITUDE	
	ENGLISH UNITS	SI UNITS
100% SPEED	3,862 RPM	404 RAD/S
100% TORQUE	280,455 IN./LBS	31,687 N-M
TANGENTIAL LOAD	3,018 LBS/STAR	13,425 N/STAR
RADIAL LOAD	1,158 LBS/STAR	5,151 N/STAR

Figure 4-12. Ring Gear High Stress Areas (Identification For Table 4-18)
Class A (OTW) Reduction Gear.

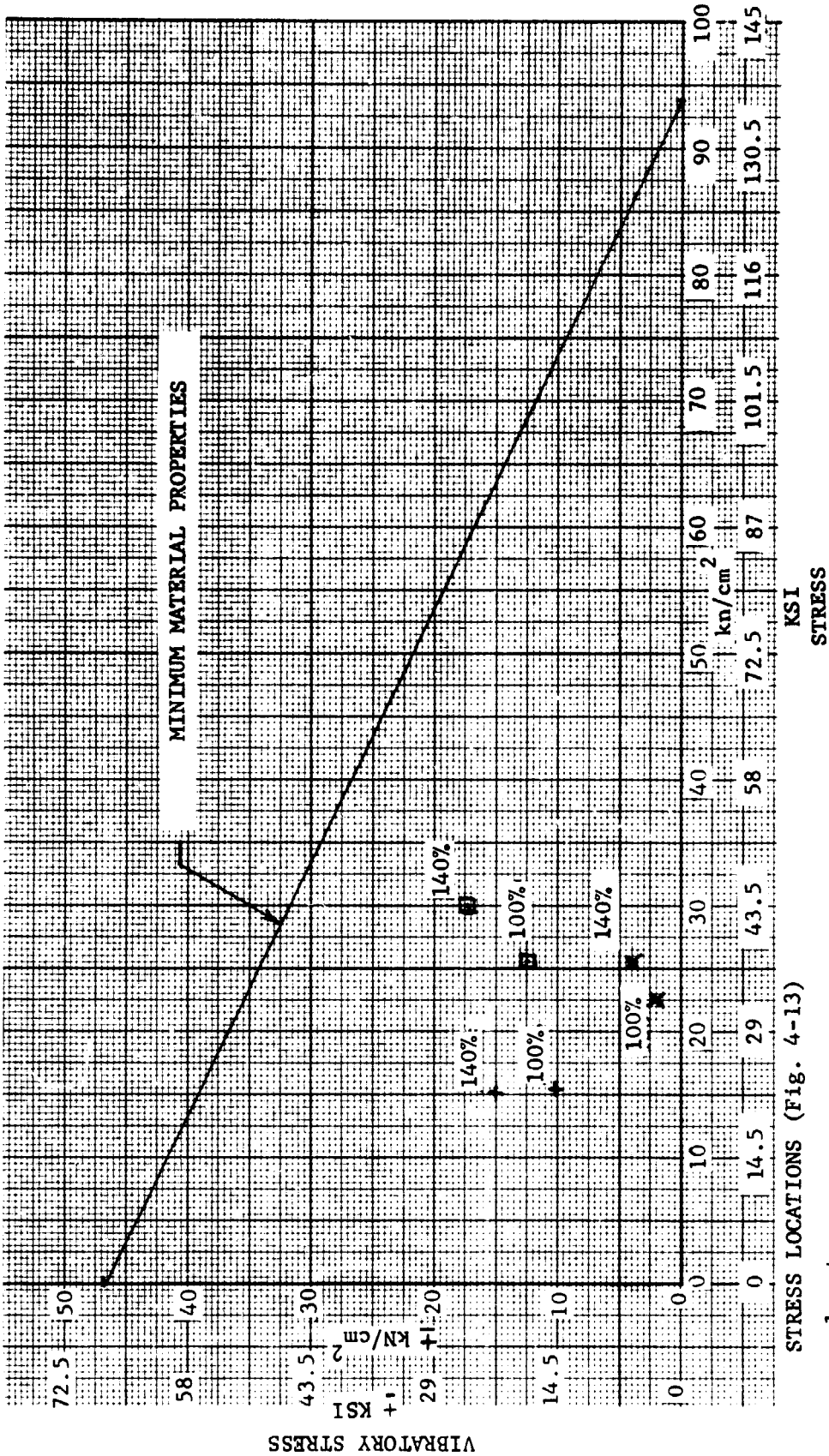

STRESS LOCATIONS (Fig. 4-13)

- 1 +
- 2 □
- 3 x

MATERIAL - AMS 6470

Figure 4-13. Ring Gear Backing Stress For 100% & 140% Torque Class A (OTW) Reduction Gear.

ORIGINAL PAGE IS OF POOR QUALITY

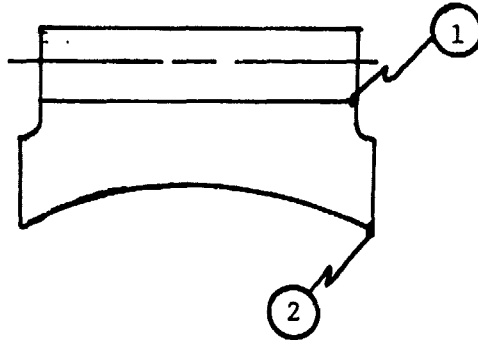

① NUMBERS IDENTIFY STRESS ANALYSIS AREAS, TABLE 4-19

REFERENCE 100% SPEED AND LOAD DATA

DATA ITEM	DATA ITEM MAGNITUDE	
	ENGLISH UNITS	SI UNITS
100% SPEED	14,998 RPM	1,591 RAD/S
100% TORQUE	9,027 IN./LB	1,020 N-M
TANGENTIAL LOAD	3,018	13,425 N/STAR
RADIAL LOAD	1,158	5,151 N/STAR

Figure 4-14. Star Gear High Stress Areas (Identification For Table 4-19)
Class A (OTW) Reduction Gear.

TABLE 4-19a

CLASS A (OTW) REDUCTION GEAR
 STAR GEAR BACKING STRESS (N/cm²) (SI UNITS)
 100% SPEED - (1,591 rad/sec)

Stress Area Fig. 4-14	Load	Circumferential Stress			
		At Mesh		Between Meshes	Equivalent
		Front	Back		
100% TORQUE (1,020 N-M)					
1	Rad	- 4,901	- 4,901	+ 2,269	
	Tang	+ 7,647	- 7,647	-	
	Centri	+13,134	+13,134	+13,134	+ 8,233
	Total	+15,880	+ 586	+16,092	<u>+ 7,647</u>
2	Rad	+ 4,725	+ 4,725	- 3,226	
	Tang	- 7,373	+ 7,373		+17,570
	Centri	+13,134	+13,134	+13,134	<u>+ 7,772</u>
	Total	+10,486	+25,231	+ 9,908	
140% TORQUE - (2,372 N-M)					
1	Rad	- 6,861	- 6,861	3,176	
	Tang	+10,705	-10,705	-	+ 6,273
	Centri	+13,134	+13,134	+13,134	<u>+10,706</u>
	Total	+16,978	- 4,433	+16,310	
2	Rad	+ 6,615	+ 6,615	- 4,517	
	Tang	-10,321	+10,321	-	+19,344
	Centri	+13,134	+13,134	+13,134	<u>+10,727</u>
	Total	+ 9,427	+30,070	+ 8,617	
Abbreviations: Radial - Rad Centrifugal - Centri Tangential - Tang Toroidal Moment - T.M.					

TABLE 4-19b
 CLASS A (OTW) REDUCTION GEAR
 STAR GEAR BACKING STRESS (PSI) (ENGLISH UNITS)
 100% SPEED - 14998 RPM

Stress Area Fig. 4-14	Load	Circumferential Stress				Equivalent
		At Mesh		Between Meshes		
		Front	Back			
100% TORQUE (9,027 IN-LB)						
1	Rad	- 7,108	- 7,108	+ 3,291		
	Tang	+11,091	- 11,091	-		
	Centri	+19,049	+19,049	+19,049	+11,941	
	Total	+23,032	+ 850	+23,340	+11,091	
2	Rad	+ 6,853	+ 6,853	- 4,679		
	Tang	-10,693	+10,693	-	+25,483	
	Centri	+19,049	+19,049	+19,049	+11,273	
	Total	+15,209	+36,595	+14,370		
140% TORQUE - (20,997 IN.-LB.)						
1	Rad	- 9,951	- 9,951	- 4,607		
	Tang	+15,527	-15,527	-	+ 9,098	
	Centri	+19,049	+19,049	+19,049	+15,527	
	Total	+24,625	- 6,429	23,656		
2	Rad	+ 9,594	+ 9,594	- 6,551		
	Tang	-14,970	+14,970	-	+28,056	
	Centri	+19,049	+19,049	+19,049	+15,558	
	Total	+13,673	+43,613	+12,498		
Abbreviations: Radial Tangential - Tang Centrifugal - Centri Toroidal Moment - T.M.						

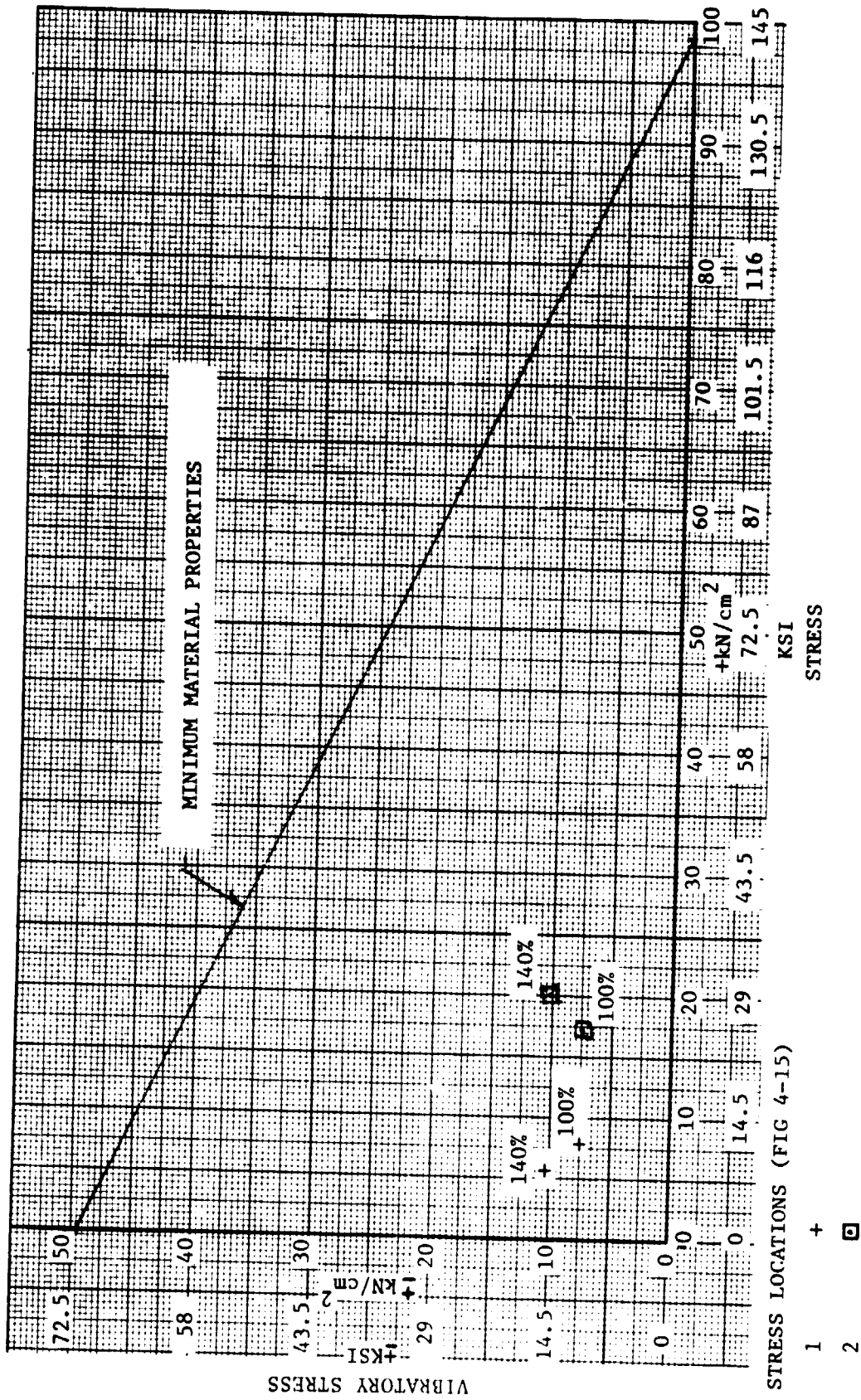

Figure 4-15. Star Gear Backing Stress For 100% Speed, 100% And 140% Torque Class A (OTW) Reduction Gear.

ORIGINAL PAGE IS
OF POOR QUALITY

TABLE 4-20a
 CLASS A (OTW) REDUCTION GEAR
 "COMBINED" STRESS (N/cm²) (SI UNITS)
 100% SPEED

INCLUDES STRESS CONCENTRATION FACTORS

Torque	Gear	Location (Fig. 3-12)	I	II	III	Equivalent
100%	Sun	A1	+23,818	0	0	+14,560
		A2	-	-23,818	0	
		B	+21,601	+ 7,519	+22,715	
		Total	+45,419	-16,299	+22,715	
100%	Ring	A1	+18,523	0	0	+15,354
		A2	0	-18,523	0	
		B	+23,003	+ 6,791	+39,506	
		Total	+41,526	-11,747	+39,506	
100%	Star	A1	+21,618	0	0	+12,350
		A2	0	-21,618	0	
		B	+23,820	+ 879	+23,104	
		Total	+45,438	-20,739	+23,104	
140%	Sun	A1	+33,345	0	0	+12,375
		A2	0	-33,345	0	
		B	+22,234	+ 2,517	+23,794	
		Total	+55,579	-30,828	+23,794	
140%	Ring	A1	+25,933	0	0	+10,810
		A2	0	-25,933	0	
		B	+22,155	- 542	+45,259	
		Total	+48,087	-26,469	+45,259	
140%	Star	A1	+30,265	0	0	+ 9,409
		A2	0	-30,265	0	
		B	+25,468	- 6,649	+24,465	
		Total	+55,733	-36,915	+24,465	

TABLE 4-20b
 CLASS A (OTW) REDUCTION GEAR
 "COMBINED" STRESS (PSI) (ENGLISH UNITS)
 100% SPEED

INCLUDES STRESS CONCENTRATION FACTORS

Torque	Gear	Location (Fig. 3-12)	I	II	III	Equivalent
100%	Sun	A1	+34,545	0	0	+21,117
		A2	0	-34,545	0	
		B	+31,329	+10,905	+32,946	
		Total	+65,874	-23,640	+32,946	
100%	Ring	A1	+26,866	0	0	+22,269
		A2	0	-26,886	0	
		B	+33,363	+ 9,849	+57,299	
		Total	+60,229	-17,037	+57,299	
100%	Star	A1	+31,354	0	0	+17,912
		A2	0	-31,354	0	
		B	+34,548	+ 1,275	+33,510	
		Total	+65,902	-30,079	+33,510	
140%	Sun	A1	+48,363	0	0	+17,949
		A2	0	-48,363	0	
		B	+32,247	+ 3,651	+34,511	
		Total	+80,610	-44,712	+34,511	
140%	Ring	A1	+37,612	0	0	+15,678
		A2	0	-37,612	0	
		B	+32,133	- 786	+65,642	
		Total	+69,745	-38,390	+65,642	
140%	Star	A1	+43,896	0	0	+13,647
		A2	0	-43,896	0	
		B	+36,938	- 9,644	+35,484	
		Total	+80,834	-53,540	+35,484	

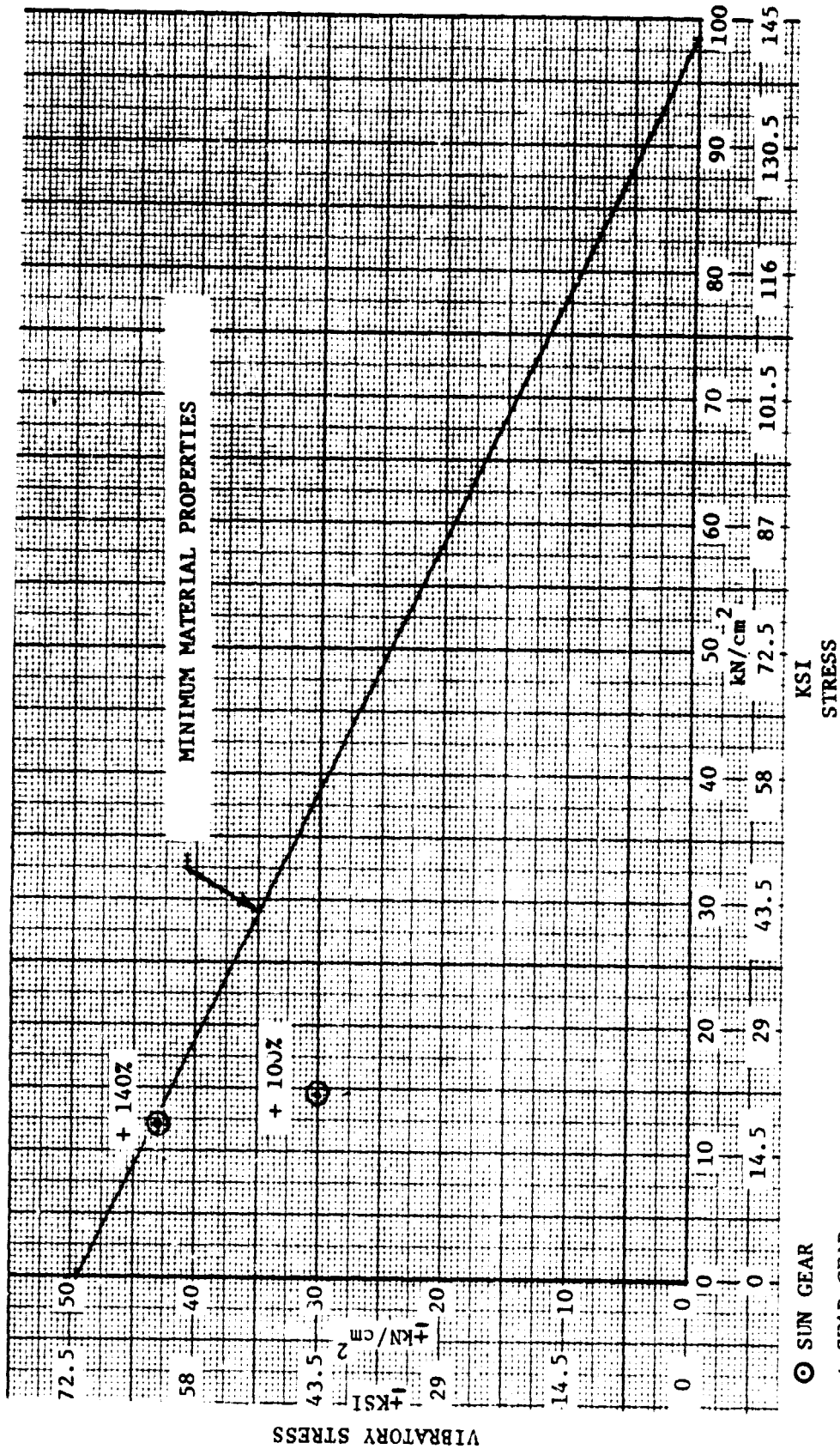

MATERIAL - AMS 6265

Figure 4-16. Sun And Gear "Combined" Stresses For 100% And 140% Torque Class A (OTW) Reduction Gear.

ORIGINAL PAGE IS OF POOR QUALITY

Ring Gear - The detailed stress values used to estimate the "combined" stress for the ring gear are shown on Table 4-20. The mean and vibration stresses for the 100% and 140% torque operation are plotted on the Goodman diagram shown in Figure 4-17. The vibratory margins are 1.49 and 1.12 for the 100% and 140% torque points, respectively.

Star Gear - The "combined" stress data for the star gear are shown in Table 4-20 and the Goodman diagram is shown in Figure 4-16. The vibratory margins are 1.31 for 100% and 0.963 for the 140% torque. Taking into consideration, the effect of shot peening and the conservative analysis procedures, the star gear should be satisfactory for the 140% torque operation.

4.2.4 Stresses Due to Flight

Maneuver loads for the OTW application were established in the same manner as for the UTW. General Electric supplied the results of their dynamic analysis of the entire rotating system which were converted to differential deflections at the ring-to-star mech and the sun-to-star mesh. Table 4-21 shows the deflections for the four types of loading analyzed. The blade out load condition reflects the expected damage in the fan when a severe failure occurs. The fan has metal blades compared to the composite blades for the UTW unit. The critical load conditions from the MIL-E-5007C specification are also shown on the Table 4-21. Several of the possible combinations of loads are included and were used in the analysis.

In relating the deflections to the separating forces involved, the radial spring rates of the three components were evaluated. The radial deflections for the gear under a 4448 N (1000 pound) load are:

Gear	Deflection	
	mm	mils
Sun	0.1715	6.75
Star	0.0183	0.72
Ring	0.0178	0.70

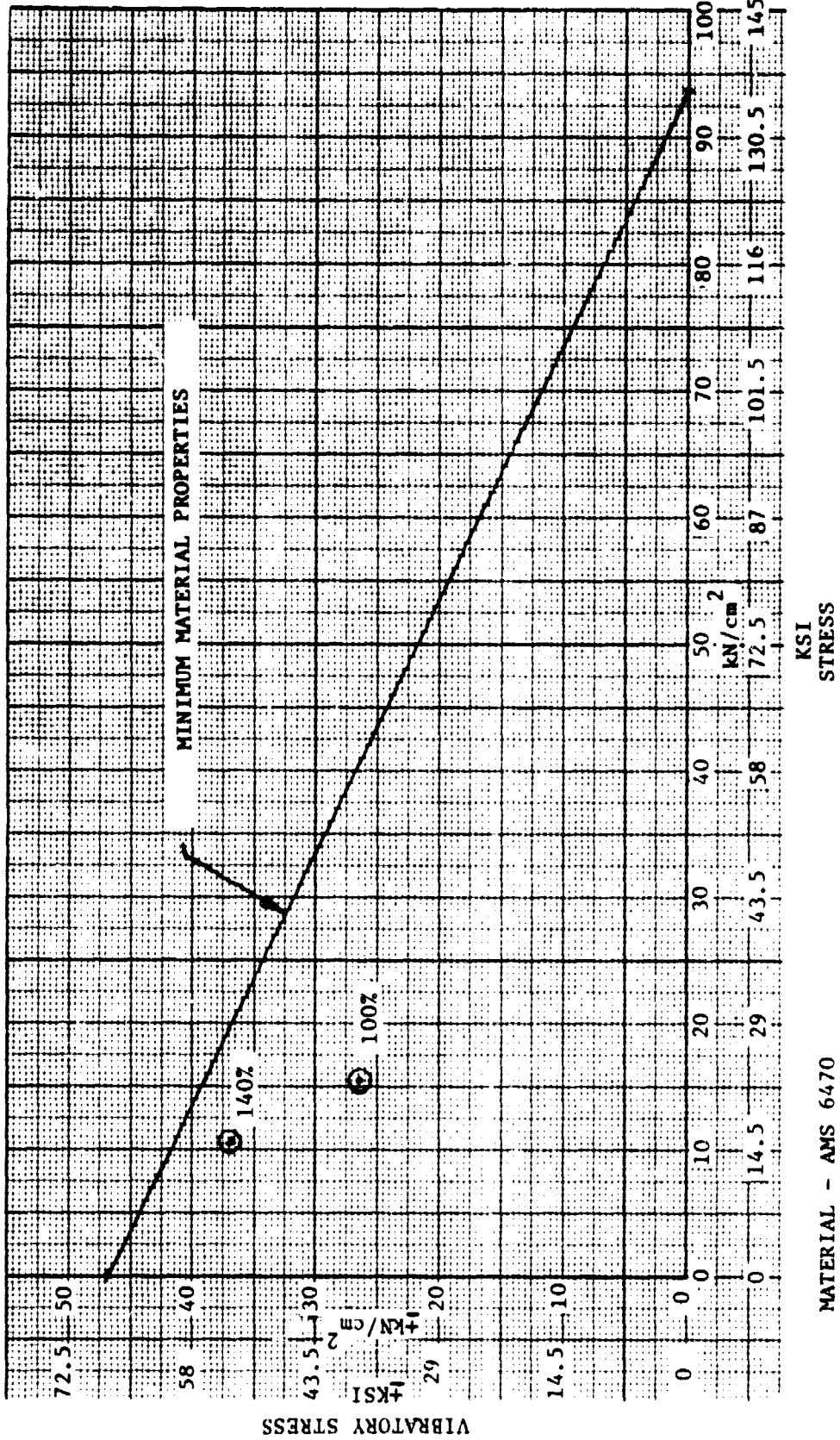

MATERIAL - AMS 6470

Figure 4-17. Ring Gear "Combined" Stress For 100% And 140% Torque Class A (OTW) Reduction Gear.

TABLE 4-21
 CLASS A (OTW) REDUCTION GEAR
 MANEUVER LOADS

Differential Deflection
 (Based on G.E. Dynamic Analysis)

Maneuver	Ring to Star		Sun to Star	
	mm	Mils	mm	Mils
10 G	.0356	1.40	.2316	9.12
14 Rad/Sec ²	.0090	0.35	.0239	0.94
1 Rad/Sec	.0396	1.56	.0719	2.83
0.77 Blades Out	.1770	6.97	.0274	1.08

Critical Load Conditions
 (Specification MIL-E-5007C)

<u>Condition</u>	<u>Flight</u>			<u>Landing</u>
Power	Maximum			100%
"G" Down	10	6	10	10
"G" Side	-	4	1.5	2
"G" Forward	2	3	2	10
Pitch Velocity Rad/Sec	0	1	0	0
Pitch Accel. Rad/Sec ²	+ 6	0	0	<u>+14</u>
Yaw Accel. Rad/Sec ²	0	0	0	<u>+ 6</u>

Table 4-22 shows the summary of the combined loads for flight and landing and indicates that the more severe case is for flight. The increase in load on the carrier support resulting from the additional radial loads from the ring gear and sun gear causes the following equivalent increase in torque:

Gear	Increase - %
Sun	10.3
Ring	14.5
Star	12.4

The increase in torque is for a particular star mesh and is accompanied by an equivalent decrease in torque at another star mesh. The backing stresses for this increase in torque are shown in Table 4-23 and titled "Flight Maneuvers Plus 100% Speed and Torque". For the so called "combined" stresses, Table 4-24 shows the values. The Goodman diagram for the "combined" stress is Figure 4-18 for the sun and star gears. The vibratory margins of 1.25 for the sun and 1.15 for the star are considered satisfactory. Figure 4-19 shows the Goodman diagram for the ring gear material AMS 6470. The 1.34 vibratory margin for the ring gear is satisfactory.

The fan blade out load (assumed by G.E. to be equivalent to 0.77 times the weight of one complete fan blade) is equal to the following increases in torque:

Gear	Increase - %
Sun	16.3
Ring	22.9
Star	19.6

Resulting gear stresses will be less than those for the 140% torque operation which will be run during the experimental engine tests and should not cause any difficulties. It should also be noted that operation after a fan blade failure will be an emergency condition that will not be continued for an extended period of time.

TABLE 4-22a
CLASS A (OTW) REDUCTION GEAR
MANEUVER LOADS (SI UNITS)

Flight		
Load	Differential Deflection - mm	
	Ring to Star	Sun to Star
7.81 "G"	.0277	.1808
1 Rad/Sec	.0396	.0719
Total	.0673	.2527
Separative Load	8313 N	5921 N
Landing		
10.2 "G"	.0378	.2461
15.23 Rad/Sec ²	.0097	.0025
Total	.0475	.2487
Separative Load	5849 N	5827 N
Blade Out		
Total	.1770	.0274
Separative Load	21823 N	641 N

TABLE 4-22b
 CLASS A (OTW) REDUCTION GEAR
 MANEUVER LOADS (ENGLISH UNITS)

<u>Flight</u>		
Load	Differential Deflection - Mils	
	Ring to Star	Sun to Star
7.81 "G"	1.09	7.12
1 Rad/Sec	1.56	2.83
Total	2.65	9.95
Separative Load	1869 lbs	1331 lbs
<u>Landing</u>		
10.2 "G"	1.49	9.69
15.23 Rad/Sec ²	0.38	0.10
Total	1.87	9.79
Separative Load	1315 lbs	1310 lbs
<u>Blade Out</u>		
Total	6.97	1.08
Separative Load	4906 lbs	144 lbs

TABLE 4-23a

CLASS A (OTW) REDUCTION GEAR

BACKING STRESS (N/cm²) (SI UNITS)

HOOP STRESS AT POINT NO. 1 FOR ALL COMPONENTS

FLIGHT MANEUVERS PLUS 100% SPEED AND TORQUE

Gear	Load	At Mesh		Between Meshes	Equivalent
		Front	Back		
Sun	Rad.	- 5,410	- 5,410	+ 587	
	Tang.	+ 5,177	+ 5,177	-	
	Centr.	+13,344	+13,344	+13,344	+ 9,742
	T.M.	+ 1,398	+ 1,398	+ 1,398	+ 5,588
	Total	+14,509	+ 4,155	+15,329	
Ring	Rad.	-10,820	-10,820	+ 7,957	
	Tang.	+ 5,841	- 5,841	-	
	Centr.	+16,750	+16,750	+16,750	+15,414
	T.M.	+ 3,016	+ 3,016	+ 3,016	+12,309
	Total	+14,786	+ 3,105	+27,722	
Star	Rad.	- 5,839	- 5,839	+ 2,703.	
	Tang.	+ 9,111	- 9,111	-	+ 7,005
	Centr.	+13,134	+13,134	+13,134	+ 8,285
	Total	+16,405	- 1,816	+15,837	
Abbreviations:					
Radial - Rad		Centrifugal - Centri			
Tangential - Tang		Toroidal Moment - T.M.			

TABLE 4-23b

CLASS A (OTW) REDUCTION GEAR

BACKING STRESS (PSI) (ENGLISH UNITS)

HOOP STRESS AT POINT NO. 1 FOR ALL COMPONENTS

FLIGHT MANEUVERS PLUS 100% SPEED AND TORQUE

Gear	Load	At Mesh		Between Meshes	Equivalent
		Front	Back		
Sun	Rad.	- 7,846	- 7,846	+ 852	
	Tang.	+ 7,509	+ 7,509	-	
	Centr.	+19,354	+19,354	+19,354	+14,130
	T.M.	+ 2,027	+ 2,027	+ 2,027	+ 8,104
	Total	+21,044	+ 6,026	+22,233	
Ring	Rad.	-15,693	-15,693	+11,540	
	Tang.	+ 8,471	- 8,471	-	
	Centr.	+24,294	+24,294	+24,294	+22,356
	T.M.	+ 4,374	+ 4,374	+ 4,374	+17,852
	Total	+21,446	+ 4,504	+40,208	
Star	Rad.	- 8,469	- 8,469	+ 3,921	
	Tang.	+13,214	-13,214	-	+10,160
	Centr.	+19,049	+19,049	+19,049	+12,002
	Total	+23,794	- 2,634	+22,970	
Abbreviations:					
Radial - Rad		Centrifugal - Centri			
Tangential - Tang		Toroidal Moment - T.M.			

TABLE 4-24a
CLASS A (OTW) REDUCTION GEAR
"COMBINED" STRESS (N/cm²) (SI UNITS)
INCLUDES STRESS CONCENTRATION FACTORS
FLIGHT MANEUVERS PLUS 100% SPEED AND TORQUE

Gear	Location (Fig. 3-12)	I	II	III	Equivalent
Sun	A ₁	+26,271	0	0	
	A ₂	0	-26,271	0	
	B	+21,764	+ 6,232	+22,994	+13,964
	Total	+47,966	-20,039	+22,994	-34,003
Ring	A ₁	+21,200	0	0	
	A ₂	0	-21,200	0	+13,419
	B	+22,180	+ 4,658	+41,584	-29,961
	Total	+43,380	-16,542	+41,584	
Star	A ₁	+24,294	0	0	
	A ₂	0	-24,294	0	+10,942
	B	+24,608	- 2,724	+23,756	+37,961
	Total	+48,902	-27,019	+23,756	

TABLE 4-24b
 CLASS A (OTW) REDUCTION GEAR

"COMBINED" STRESS (PSI) (ENGLISH UNITS)
 INCLUDES STRESS CONCENTRATION FACTORS
 FLIGHT MANEUVERS PLUS 100% SPEED AND TORQUE

<u>Gear</u>	<u>Location</u> (Fig. 3-12)	<u>I</u>	<u>II</u>	<u>III</u>	<u>Equivalent</u>
Sun	A ₁	+38,103	0	0	
	A ₂	0	-38,103	0	
	B	+31,566	+ 9,039	+33,350	+20,253
	Total	+69,569	-29,064	+33,350	+49,317
Ring	A ₁	+30,748	0	0	
	A ₂	0	-30,748	0	+19,463
	B	+32,169	+ 6,756	+60,312	+43,455
	Total	+62,917	-23,992	+60,312	
Star	A ₁	+35,236	0	0	
	A ₂	0	-35,236	0	+15,870
	B	+35,691	- 3,951	+34,455	+55,058
	Total	+70,927	-39,188	+34,455	

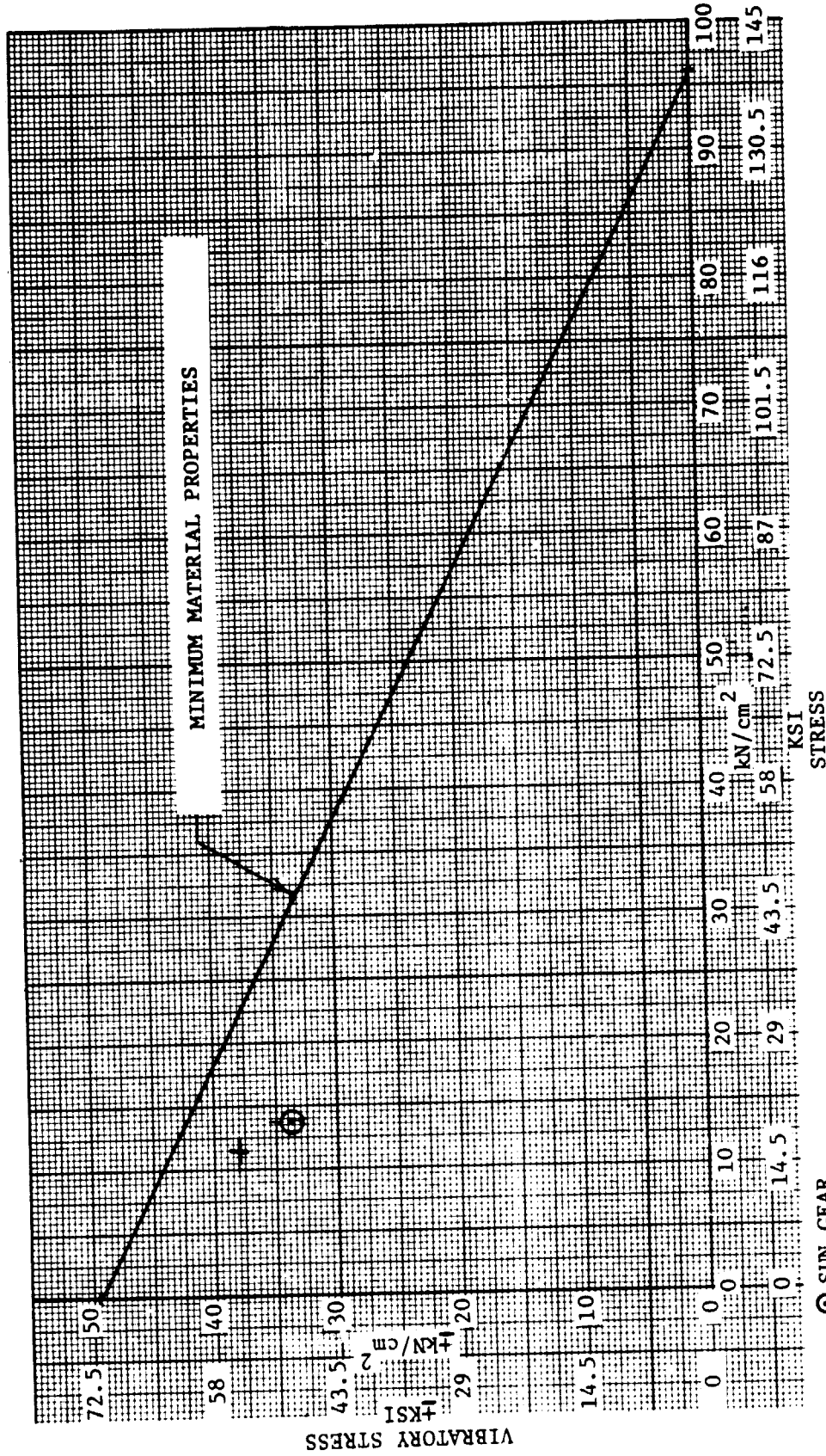
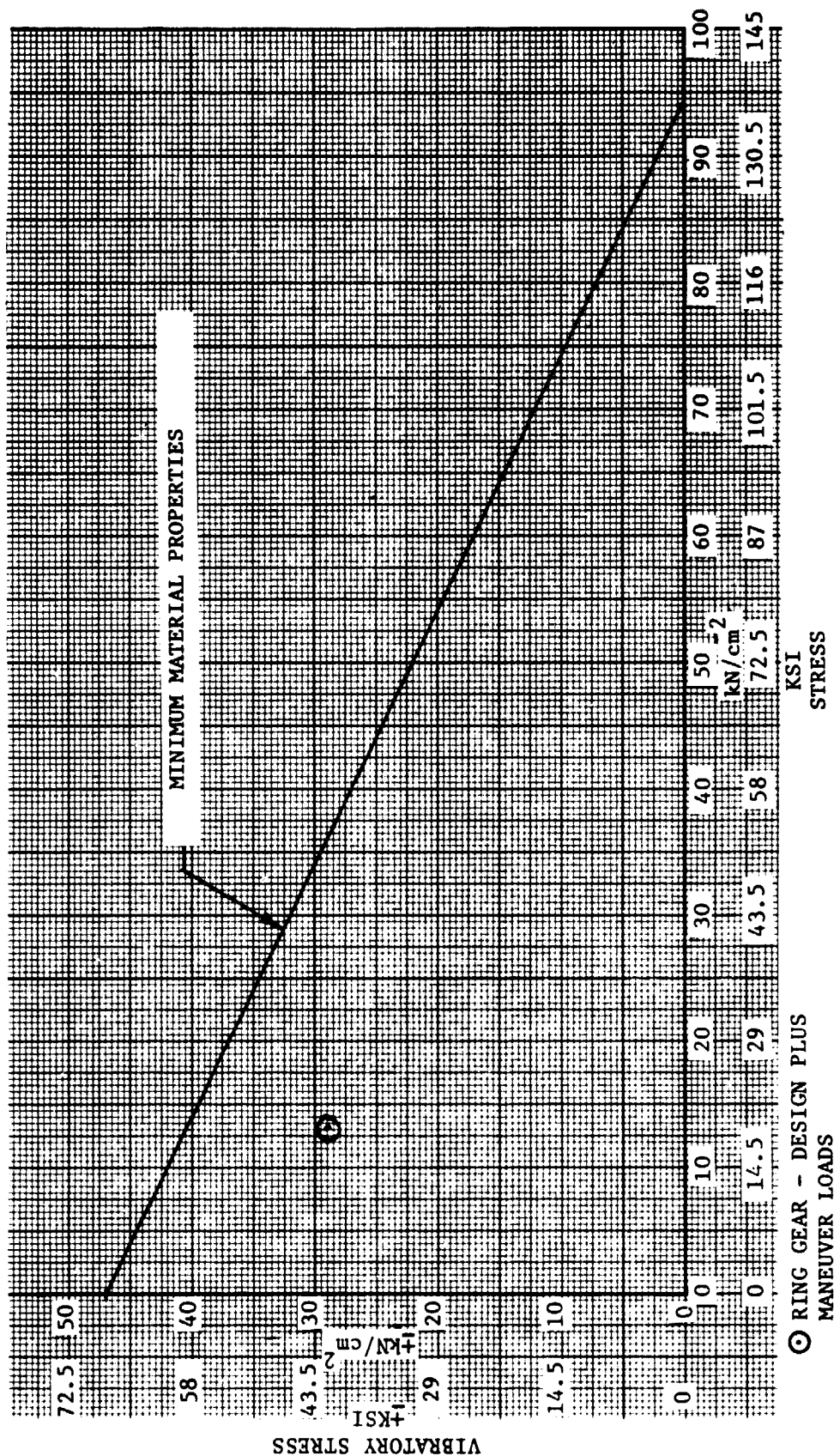

Figure 4-18. Sun And Star Gear "Combined" Stresses With Design Plus Maneuver Loads Class A (OTW) Reduction Gear.



⊙ RING GEAR - DESIGN PLUS MANEUVER LOADS
 MATERIAL - AMS 6470
 Figure 4-19. Ring Gear "Combined" Stress With Design Plus Maneuver Loads Class A (OTW) Reduction Gear.

4.2.5 Star Gear Carrier Support Stress

The OTW star gear support was stress analyzed in the same way the UTW unit support was analyzed. The loads and dimensions were changed as necessary for the eight stars in the OTW unit design. Figure 3-22 shows the location of the critical areas where the stresses were calculated. Table 4-25 shows the carrier stresses for various load conditions. At the base of the post the maximum equivalent stress due to normal operation is 5345 N/cm^2 (7,825 psi). Only the stresses at points 3 and 4, intersection of the conical inner and outer surfaces, respectively, with the ring supporting the posts, are shown on this Table since they are the largest. The stress of point 3 is 5227 N/cm^2 (7,581 psi). These stresses are due to torque and therefore little vibratory effect is expected. Taking into consideration stress concentration factors and the overload torque condition, the vibratory margins, for a minimum endurance strength of $\pm 51,700 \text{ N/cm}^2$ ($\pm 75,000$ psi), are very satisfactory.

A total load of 4448N (1,000 pounds) was applied to the carrier through the posts to simulate a 10 'G' vertical load (conservatively estimated as 10 times the weight of the ring gear, eight stars and sun gear). An equivalent stress of $14,658 \text{ N/cm}^2$ (21,259 psi) occurs at point 5A, about one-sixth of the minimum yield strength of this material, AMS 6415.

The bearing load for the fan blade out condition was obtained from the results of the system dynamic analysis performed by General Electric. The highest equivalent stress in the carrier due to the blade out load will be 7918 N/cm^2 (11,484 psi) at point 5B and will be vibratory. If a conservative stress concentration factor of 3.0 is applied, a vibratory margin of over 2.0 will exist. Blade out operation will not damage the carrier.

4.2.6 Flex Coupling

The diaphragm type flexible coupling that connects the sun gear to the turbine drive shaft is identical for the OTW and UTW reduction gear designs. The method of analysis is detailed in the UTW unit discussion, Section 3.2.6. Since the normal speed and torque loads for the OTW unit are higher, the stresses calculated for them were presented in Table 3-29. The highest

TABLE 4-25

CLASS A (OTW) REDUCTION GEAR
 STAR GEAR CARRIER SUPPORT STRESS
 100% DESIGN PLUS MANEUVER LOADS

SI UNITS

Load	Location	STRESS - N/cm^2			
		Hoop	Longitudinal	Shear	Equivalent
100% Torque	Post	-	+ 3,748	+2,241	5,395
	3	+ 907	+ 827	+3,976	5,227
	4	+ 374	- 2,142	+2,442	4,671
0.77 Blade Out	5A	-4,309	- 7,415	- 104	6,452
	5B	+ 345	+ 7,952	+ 832	7,918
	1	-	+ 1,014	+1,781	3,247
	3	+ 806	+ 1,250	+ 917	1,098
	4	+ 154	+ 830	+ 705	1,527
	5A	+6,149	-10,579	+ 150	14,658
	5B	+ 492	+11,347	+1,187	11,298

ENGLISH UNITS

Load	Location	STRESS - PSI			
		Hoop	Longitudinal	Shear	Equivalent
100% Torque	Post	-	+ 5,436	+3,250	7,825
	3	+1,315	+ 1,200	+4,316	7,581
	4	- 543	- 3,107	+3,542	6,775
10 "G" Down	5A	-6,250	-10,754	+ 151	9,358
	5B	+ 500	+11,534	+1,207	11,484
	1	-	+ 1,470	+2,583	4,709
	3	+1,169	+ 1,813	+1,330	1,592
	4	+ 224	- 1,204	+1,022	2,214
	5A	+8,918	-15,344	+ 217	21,259
	5B	+ 714	+16,457	+1,722	16,386

equivalent stress occurs at point 2 (Figure 3-22), outer surface of the cylindrical section at intersection with the diaphragm fillet, where the equivalent stress is $22,738 \text{ N/cm}^2$ (32,979 psi). This stress is less than one-third the minimum yield strength of $83,806 \text{ N/cm}^2$ (121,550 psi).

Table 4-26 shows the coupling stress for the maneuver and blade out loads. The maneuver loads cause a maximum equivalent stress of 7540 N/cm^2 (10,936 psi) at point 5, inner surface of the cylindrical section at intersection with the diaphragm fillet, just about the same as for the UTW unit. The blade out stress is only one-fifth of that for the OTW unit design. This is a direct result of the reduction in the differential deflection between the sun and star gears shown on Table 4-22 for blade out. The maximum equivalent stress is less than 1379 N/cm^2 (2,000 psi).

4.3 Deflection Analysis

A detailed discussion of the method of deflection analysis for each of the three gear elements is given for the UTW unit design, Section 3.3. Table 4-27 shows the results of the analysis for the OTW unit design. Data are shown for the two major contributors of deflection and given in the form of a radial slope in the axial direction as well as the effective tangential slope in the direction of rotation. For both the sun and ring gears the centrifugal forces cause a twist opposite to that due to the gear separating forces. For the ring gear the centrifugal effect is approximately 4% of the final twist while for the sun gear the effect is approximately 34%.

The OTW sun gear tooth contact line total axial slope of $200 \times 10^{-6} \text{ in./in.}$ is only slightly over 50% of that for the UTW unit. The centrifugal force restoring effect is approximately one-third the gear tooth separating force effect. The ring gear axial slope of $1545 \times 10^{-6} \text{ in./in.}$ due to radial gear tooth separating force is slightly less than the comparable UTW unit slope, implying a stiffer ring. Although the OTW unit centrifugal force effect is greater than the UTW unit, the total or resulting slope is only 14% less than the comparable UTW unit slope.

TABLE 4-26

CLASS A (OTW) REDUCTION GEAR

FLEXIBLE COUPLING STRESS

MANEUVER AND BLADE OUT LOADS

SI UNITS

Point Fig. 3-23	STRESS - N/cm ²			
	Hoop	Longitudinal	Shear	Equivalent
<u>Maneuver Loads</u>				
1	-1,586	-1,891	- 179	1,786
2	+4,780	+8,043	- 211	7,016
3	-2,079	-4,378	- 43	1,900
4	- 543	+1,436	-1,551	3,217
5	+ 41	-7,392	+ 797	7,540
6	+1,142	+4,684	- 43	4,231
<u>Blade Out Loads</u>				
1	- 172	- 204	- 19	193
2	+ 855	+1,089	66	1,000
3	- 225	- 474	- 6	410
4	- 59	+ 155	+ 168	347
5	0	- 998	+ 110	1,016
6	+ 123	+ 507	+ 10	458

ENGLISH UNITS

Point Fig. 3-23	STRESS - PSI			
	Hoop	Longitudinal	Shear	Equivalent
<u>Maneuver Loads</u>				
1	-2,301	- 2,743	- 260	2,590
2	+6,933	+11,665	- 306	10,176
3	-3,016	- 6,350	- 62	2,756
4	- 787	+ 2,083	+2,249	4,666
5	+ 60	-10,721	+1,156	10,936
6	+1,657	+ 6,794	- 62	6,137
<u>Blade Out Loads</u>				
1	- 249	- 297	- 28	280
2	+1,240	+ 1,580	- 95	1,450
3	- 326	- 687	- 9	595
4	- 85	+ 225	+ 243	504
5	0	- 1,448	+ 159	1,474
6	+ 179	+ 735	+ 15	664

TABLE 4-27
CLASS A (OTW) REDUCTION GEAR

GEAR TOOTH DEFLECTION

Gear	Load	Slope - 10^{-6} In./In.	
		Axial	Tangential
Sun	Radial	- 267	
	Centrifugal	+ 67	
	Total	- 200	- 77
Ring	Radial	+1,545	
	Centrifugal	- 63	
	Total	+1,482	+569
Carrier	Post		302
	Backing Ring		27
	Total		+329

C-3

Deformation analysis of the star gear journal under load showed an average slope of 302×10^{-6} in./in. in a tangential or torque direction. The contribution of the carrier backup structure was calculated by applying a tangential load in the plane of the carrier ring and a couple at each of the eight posts. The analysis, using the K Shell 1 computer program, showed the post would have an additional slope due to the backing ring of 27×10^{-6} in./in., the same as for the UTW unit. The total tangential slope of the OTW is 329×10^{-6} , 25% greater than the UTW unit post slope.

In summary, for the design speed and torque, the tangential slopes of the gear tooth contact lines will be:

Gear	Slope
Ring	569×10^{-6} in./in.
Carrier - Star	329×10^{-6} in./in.
Sun	77×10^{-6} in./in.

The star gear spherical bearings, between the carrier post and the star gear, will accommodate any mismatch between the deflection slopes of the three gear elements without serious skew. Uniform tooth loading patterns are expected during the service life of the unit.

4.4 Natural Frequencies

The interference diagram for the ring gear and sun gear is shown in Figure 4-20. The prime mode of vibration for the gears will be the eight diameter mode (16 nodes) and an estimate of the natural frequency values for the initial design are:

Ring Gear	-	1,630 Hertz
Sun Gear	-	10,200 Hertz

The anticipated speed range of the unit is shown on the bottom of the figure, 15 to 102%. There will be no major resonances in the speed range due to star passing excitation. Two minor resonances, due to gear tooth meshing excitations, could occur; the ring gear near 15% speed and the sun gear at 96% speed.

The ring gear resonance is not considered serious because of the low speed at which it occurs. Raising the sun gear resonance point above the operating speed range can be accomplished by increasing the gear rim thickness and a decision was made to do this to avoid the possibility of an undesirable noise or wear condition.

Experimental tests conducted on a partially machined sun gear indicated that the actual natural frequency was somewhat lower than the calculated value. The sun gear specification was revised prior to final machining to increase the rim thickness and raise the natural frequency above 11,900 hz, placing the gear tooth meshing excitation resonance with the sun gear above 112% rated speed which is 10% above the maximum operating speed, an acceptable operating margin.

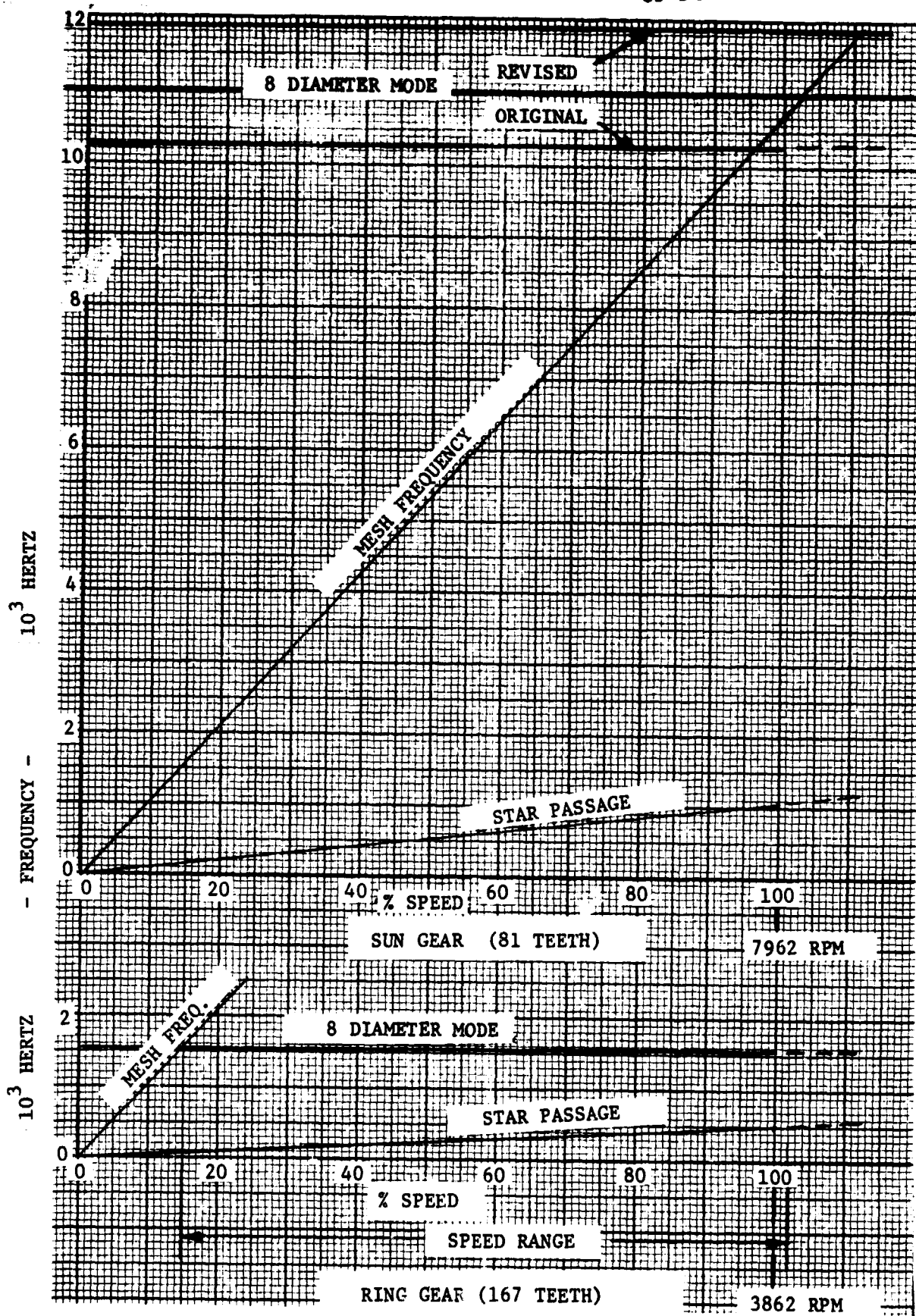

Figure 4-20. Interference Diagram Class A (OTW) Reduction Gear.

5.0 CONCLUSIONS ON SUMMARY OF RESULTS

The design and analysis effort reported herein demonstrates the practicality of lightweight engine-to-fan gear speed reducers, thus enabling the development of high performance turbofan engines utilizing high speed gas turbines driving slower speed fans.

Two epicyclic, star configuration, speed reducer gears for the General Electric/NASA Quiet Clean Short-haul Experimental Engine (QCSEE) under-the-wing (UTW) and over-the-wing (OTW) configuration programs were designed and analyzed. Gear reduction ratios and input 100% power and speed design conditions are as follows:

Engine Application	UTW	OTW
Reduction Ratio	2.465	2.062
100% Power	9885 kW (13256 hp)	12813 kW (17183 hp)
100% Speed (Input)	811 rad/s (7747 rpm)	834 rad/s (7962 rpm)

Significant features incorporated in the QCSEE main reduction gear designs include the following:

1. Modular concept to permit installation and removal of the reduction gear and fan output shaft assembly as a unit.
2. Epicyclic gear with star arrangement; power input to sun gear, output from ring gear and stationary star gear support.
3. Identical interface points between the reduction gear and engine for the two different ratio units:
 - a. Input coupling attachment to General Electric LP turbine shaft
 - b. Star gear support interface flange
 - c. Ring gear output spline
 - d. Oil supply tube
4. Flexibility in the sun gear and ring gear mountings with controlled gear deflections between the sun gear to star gear mesh and star gear to ring gear mesh.

5. Star gears supported by spherical roller bearings to allow self-alignment with the mating gears.

6. Gear tooth contact ratio of 2.0, hunting and non-factorizing tooth numbers for quiet operation.

The gear systems, input coupling interface to ring gear output interface including the star gear stationary support, weigh 96.2 kg (204 pounds) and 89.9 kg (198 pounds) for the UTW and OTW units, respectively.

The star gear spherical roller bearings have calculated B_1 lives of 6110 hours and 5063 hours for the UTW and OTW units, respectively, based on a typical flight spectrum operation.

Calculated gear tooth maximum stresses at 100% power and speed conditions are as follows:

	sun gear	star gear	ring gear
UTW Unit:			
Bending stress -			
N/cm^2	24,869	24,042/23,366	19,595
(psi)	(36,070)	(34,870/33,890)	28,420
Contact stress -			
N/cm^2	87,329	87,329/56,461	56,461
(psi)	(126,660)	(126,660/81,890)	(81,890)
OTW Unit:			
Bending stress -			
N/cm^2	23,818	21,509/21,726	18,537
(psi)	(34,545)	(31,196/31,511)	(26,886)
Contact stress -			
N/cm^2	88,139	88,139/61,383	61,383
(psi)	(127,835)	(127,835/89,029)	(89,029)

The gear materials are AMS 6265 carburized and hardened to R_c 60-63 for the sun and star gears and AMS 6470 nitrided for the ring gears and based on Curtiss-Wright experience the above stress levels provide an adequate safety margin.

Estimated efficiencies at 100% power and speed conditions based on calculated spherical bearing, gear mesh, windage and oil churning losses are 99.3% and 99.1% for the UTW and OTW units, respectively.

Spray tube oil jet lubrication to the gears limits the calculated AGMA scoring index to 300°F maximum, an acceptable value.

The analyses predict successful operation of the reduction gears at overspeed and overload conditions of up to 105% speed at 100% power and 140% power at 100% speed as well as over the complete flight spectrum range for both back-to-back component testing and experimental engine operation.

APPENDIX - A
UTW REDUCTION GEAR BILL of MATERIAL No. 210

APPENDIX - A

UTW Reduction Gear Bill of Material No. 210



BILL OF MATERIAL NO.

210

MODEL

QCSEE (UTW)

Main Reduction Gear

CURTISS-WRIGHT CORPORATION
WOOD-RIDGE, NEW JERSEY 07075

ORIGINAL PAGE IS
OF POOR QUALITY

CURTISS-WRIGHT CORPORATION

Wood-Ridge, New Jersey

Engrg. Order Rel. 36868M

Model QCSEE (UTM) Customer(s)	Contract Number 490645	Specification Basic Drawing
Complete Assembly Drawing	Factory Order (s) 490644	Date Plate Marking Installation Drawing
Test Instruction	Index Chart for Table of Limits 490644	Original Issue Date 11-20-74
	Table of Limits Torque Values	Latest Issue Date

ORIGINAL PAGE IS
OF POOR QUALITY

SPECIAL NOTES PARTS LISTED ON WHITE PAGES OF THIS BILL OF MATERIAL ARE LATEST PARTS PROVIDED FOR USE. WHERE THE PART IS NOT YET BEING
 SET, A BLUE MARK (OTHER THAN THE NUMBER) A SIMILAR CODE MARK APPEARS ON THE PINK SHEETS. THIS CODE MARK INDICATES THE SUPPLEMENTED PART NUMBER CURRENTLY IN
 USE AND THE SERIAL NUMBERS REFERRED TO BY BLUE WITH THE CANCELLED PART.
 PARTS LISTED ON BLUE PAGES ARE FOR SPECIAL APPLICATIONS SUCH AS INSTRUMENTATION. THESE PAGES SHOW PARTS TO BE USED, MOST OMITTED
 PARTS LISTED ON BLUE PAGES ARE FOR SPECIAL APPLICATIONS.

DATE 11 20 74

BILL OF MATERIAL NO 210

BILL OF MATERIAL

MURTISS-WRIGHT CORPORATION
WOOD-RIDGE, NEW JERSEY 07075

FORM 4010 (4-64)

LINE NO.	PART NUMBER	PART OR ASSEMBLY NAME	UNIT PER ASSEMBLY	ENG. ORDER RELEASE	E.O. DATE	MATERIAL
675D4		Bolt, Hex. Head - .3125-24 UNJF-3A X .88 (SFCL) Turbine Output Shaft Coupling to Turbine Output Shaft	32			
764D107		Bolt, Hex. Head - .250-28 UNJF-3A X .75 Oil Distributing Manifold Supply Tube to Manifold	14			
2067D960		Washer, .250 Dia. Bolt Tablock (Special) Oil Distributing Manifold Supply Tube to Manifold Bolt	14			
AN960C416L		Washer - .500 X .265 X .032 Oil Distributing Manifold to Star Gear Support Bolt	6			
MS9388-011		Packing, Preformed - .301 I.D. X .070 Sun Gear Oil Spray Tube	6			
MS9388-022		Packing, Preformed - .989 I.D. X .070 Oil Distributing Manifold Supply Tube	3			
MS9388-029		Packing, Preformed - 1.489 I.D. X .070 Star Gear Oil Retaining Sleeve - Rear	6			

BILL OF MATERIAL NUMBER 210

MODEL QCSEE Main Reduction Gear (U.T.W.)

Chg A

BILL OF MATERIAL

CURTISS-WRIGHT CORPORATION
WOOD-RIDGE, NEW JERSEY 07073

FORM 6810 (4-64)

LINE NO.	PART NUMBER	PART OR ASSEMBLY NAME	UNIT PER ASBY	ENCL. ORDER RELEASE	E.O. DATE	MATERIAL
	MS9388-032	Packing, Performed - 1.864 I.D. X .070 Star Gear Oil Retaining Sleeve - Front	6			
	MS9557-09	Bolt, Double Hex Head - .250-28 UNJF-3A X .688 Sun Gear and Coupling Lock Ring to Sun Gear	4	36848K	3-75	
	MS9557-12	Bolt, Double Hex. Head - .250-28 UNJF-3A X .875 Oil Distributing Manifold to Star Gear Support	6	36848K	3-75	
	185139	Gear, Ring - Planetary Reduction	1			
	185140	Coupling, Turbine Output Shaft	1			
	185144	Tube, Sun Gear Oil Spray	6			
	185146	Ring, Sun Gear and Coupling Lock	1			
	185147	Sleeve, Star Gear Oil Retaining	4	36848F	2-75	
	185148	Nut, Star Gear Retaining	6			
	185149	Ring, Star Gear Retaining Nut Lock	6			
	185151	Ring, Large - Oil Distributing Manifold Seal	1			
	185152	Ring, Small - Oil Distributing Manifold Seal	1			

ORIGINAL PAGE IS
 OF POOR QUALITY

BILL OF MATERIAL NO. 210 Model - QCSE Main Reduction Gear (U.T.W.) Chg B

BILL OF MATERIAL

**CURTIS-WRIGHT CORPORATION
WOOD-RIDGE, NEW JERSEY 07079**

FORM 0110 10-64

LINE NO.	PART NUMBER	PART OR ASSEMBLY NAME	UNIT PER ASSY	ENG. ORDER RELEASE	E.O. DATE	MATERIAL
185153		Nut, Turbine Output Shaft Coupling Bolt	32			
185154		Ring, Star Gear Retaining Nut Lock Ring Retaining	6			
185155		Ring, Star Gear Oil Retaining Sleeve Retaining	6			
185157		Gear Bearing, Star	6			
185179		Sleeve, Star Gear Oil Retaining	2	36848P	2-75	
490639		Tube, Oil Distributing Manifold Supply - Assembly of	1			
490640		Manifold Assembly, Oil Distributing	1			
103902		Bushing - Open Screw	18			
185145 MD		Manifold, Oil Distributing	1			
490642		Gear Assembly, Sun	1			
185138 MD		Gear, Sun	1			
185156		Locknut, .250-28 UNJP-3B (Special)	4			
490643		Support Assembly, Star Gear	1			
185142 MD		Support, Star Gear	1			
185156		Locknut, .250-28 UNJP-3B (Special)	6			

ORIGINAL PAGE IS
OF P

BILL OF MATERIAL NUMBER ← 210 sheet ← QCSEE Main Reduction Gear (U.T.W.)

Chg A

PAGE 3 OF 3
DATE 3-10-75

ORIGINAL PAGE IS
OF POOR QUALITY

APPENDIX - B
UTW REDUCTION GEAR WEIGHT ANALYSIS

APPENDIX - B

UTW REDUCTION GEAR WEIGHT ANALYSIS

SHEET 1 Of 1

PART NO.	NAME	QUAN.	TOTAL WEIGHT	
			kg	lb
675D4	Bolt	32	0.450	0.992
764D107	Bolt	14	0.101	0.223
2067D960	Washer	14	0.017	0.038
AN960C416L	Washer	6	0.004	0.008
MS9388-011	Packing	6	0.001	0.002
MS9388-022	Packing	3	0.001	0.003
MS9388-029	Packing	6	0.004	0.008
MS9388-032	Packing	6	0.005	0.010
MS9557-09	Bolt	4	0.114	0.252
MS9557-12	Bolt	6	0.046	0.102
185139	Gear, Ring	1	13.56	29.90
185140	Coupling	1	2.75	6.07
185144	Spray Tube	6	0.212	0.468
185146	Ring	1	0.337	0.742
185147	Sleeve	4	0.270	0.596
185148	Nut	6	1.739	3.834
185149	Ring	6	0.131	0.288
185151	Ring, Seal	1	0.020	0.044
185152	Ring, Seal	1	0.021	0.047
185153	Nut	32	0.125	0.275
185154	Ring, Retaining	6	0.076	0.168
185155	Ring, Retaining	6	0.035	0.078
185157	Gear and Bearing	6	41.39	91.25
185179	Sleeve	2	0.118	0.260
490639	Tube, Oil	1	0.144	0.317
490640	Manifold Assembly	1	-	-
1039D2	Bushing	18	0.090	0.198
185145	Manifold	1	1.54	3.40
490642	Gear Assembly	1	-	-

PART NO.	NAME	QUAN.	TOTAL WEIGHT	
			kg	lb
185138	Gear, Sun	1	7.12	15.70
185156	Locknut	4	0.013	0.028
490643	Support Assembly	1	-	-
185142	Support	1	22.17	48.88
185156	Locknut	6	<u>0.021</u>	<u>0.046</u>
	TOTAL		92.63	204.23

APPENDIX - C
OTW REDUCTION GEAR BILL of MATERIAL No. 211

APPENDIX - C

OTW Reduction Gear Bill of Material No. 211

ORIGINAL PAGE IS
OF POOR QUALITY



BILL OF MATERIAL NO.

211

MODEL

QCSEE (O.T.W.)

MAIN REDUCTION GEAR

CURTISS-WRIGHT CORPORATION
WOOD RIDGE, NEW JERSEY 07075

CURTISS-WRIGHT CORPORATION

Wood-Ridge, New Jersey

Engrg. Order No. 36848 M

Model	Contract Number	Specification	Basic Drawing
QCSEE (O.T.W.) Customer(s)	Factory Order (s)	Date Plate Marking	490650 Installation Drawing
Complete Assembly Drawing	Index Chart for Table of Limits 490649	Table of Limits TL245	Original Issue Date 3-12-75
Test Instruction	Table of Limits Torque Values		Latest Issue Date

ORIGINAL PAGE IS
OF POOR QUALITY

SPECIAL NOTES PARTS LISTED ON WHITE PAGES OF THIS BILL OF MATERIAL ARE LATEST PARTS PROVIDED FOR USE. WHERE THE PART IS NOT YET BEING
 USED, A PINK MARK FOLLOWS THE NUMBER. A SIMILAR CODE MARK APPEARS ON THE PINK SHEETS. THIS CODE MARK INDICATES THE SUGGESTED PART NUMBER CURRENTLY IN
 USE AND THE SERIAL NUMBERS SCHEDULED TO BE BUILT WITH THE CANCELLED PART.
 PARTS LISTED ON BLUE PAGES ARE FOR SPECIAL APPLICATIONS SUCH AS INSTRUMENTATION. THESE PAGES SHOW PARTS TO BE USED, THOSE OMITTED
 QUANTITIES AND SERIAL NUMBERS FOR SPECIAL APPLICATION.

QCSEE (O.T.W.)

3111 OF MATERIAL 40 211

3-12-75

BILL OF MATERIAL

CURTISS-WRIGHT CORPORATION
WOOD-RIDGE, NEW JERSEY 07075

FORM 4816 (8-69)

LINE NO.	PART NUMBER	PART OR ASSEMBLY NAME	UNIT PER ASBY	ENG. ORDER RELEASE	E.O. DATE	MATERIAL
675D4		Bolt, Hex Hd. - .3125-24 UNJF-3A x .88 (Spcl) Turbine Output Shaft Coupling to Turbine Output Shaft	32			
764D107		Bolt, Hex Hd. - .250-28 UNJF-3A x .75 Oil Distributing Manifold Supply Tube to Manifold	18			
2067D960		Washer, Tablock - .250 Dia. Bolt (Special) Oil Distributing Manifold Supply Tube to Manifold Bolt	18			
AN960C416L		Washer - .500 x .265 x .032 Oil Distributing Manifold to Star Gear Support Bolt	6			
MS9388-011		Packing, Preformed - .301 I.D. x .070 Sun Gear Oil Spray Tube	8			
MS9388-022		Packing, Preformed - .989 I.D. x .070 Oil Distributing Manifold Supply Tube	3			
MS9388-023		Packing, Preformed - 1.051 I.D. x .070 Star Gear Oil Retaining Sleeve - Rear	8			
MS9388-029		Packing, Preformed - 1.489 I.D. x .070 Star Gear Oil Retaining Sleeve - Front	8			
MS9388-280		Packing, Preformed - 13.984 I.D. x .139 Oil Distributing Manifold Seal - Small	1			
MS9557-09		Bolt, Double Hex Hd. - .250-28 UNJF-3A x .688 Sun Gear and Coupling Lock Ring to Sun Gear	4			

BILL OF MATERIAL NUMBER 211

MODEL ← QCSEE MAIN RED. GEAR (O.T.W.)

BILL OF MATERIAL

CURTISS-WRIGHT CORPORATION
WOOD-RIDGE, NEW JERSEY 07075

FORM 40-10-59

LINE NO.	PART NUMBER	PART OR ASSEMBLY NAME	UNIT PER ASSY	ENG. ORDER RELEASE	E.O. DATE	MATERIAL
	MS9557-12	Bolt, Double Hex Hd. - .250-28 UNJF-3A x .875 Oil Distributing Manifold to Star Gear Support	6			
	185140	Coupling, Turbine Output Shaft	1			
	185146	Ring, Sun Gear and Coupling Lock	1			
	185153	Nut, Turbine Output Shaft Coupling Bolt	32			
	185159	Gear Bearing, Star	8			
	185160	Tube, Sun Gear Oil Spray	8			
	185161	Sleeve, Star Gear Oil Retaining	6	36848L	4-74	
	185163	Ring, Star Gear Retaining Nut Lock	8			
	185164	Nut, Star Gear Retaining	8			
	185165	Gear, Ring - Planetary Reduction	1			
	185167	Ring, Large - Oil Distributing Manifold Seal	1			
	185168	Ring, Star Gear Retaining Nut Lock Ring Retaining	8			
	185169	Ring, Star Gear Oil Retaining Sleeve Retaining	8			
	185225	Sleeve, Star Gear Oil Retaining	2	36858L	4-75	
	490639	Tube, Oil Distr. Manifold Supply - Assy of	1			
	490646	Gear Assy, Sun	1			
	185143 N.D.	Gear, Sun	1			
	185156	Locknut, .250-28 UNJF-3B (Special)	4			

**ORIGINAL PAGE 18
 OF POOR QUALITY**

BILL OF MATERIAL

FORM 4315 (6-69)

LINE NO.	PART NUMBER	PART OR ASSEMBLY NAME	UNIT PER ASBY	ENG. ORDER RELEASE	E.O. DATE	MATERIAL
	490647	Manifold Assy., Oil Distributing	1			
	1039D2	Bushing, Open Screw	22			
	185166 N.D.	Manifold, Oil Distributing	1			
	490648	Support Assy., Star Gear	1			
	185156	Locknut, .250-28 UNJF-3B (Special)	6			
	185170 N.D.	Support, Star Gear	1			

APPENDIX - D
OTW REDUCTION GEAR WEIGHT ANALYSIS

APPENDIX - D
 OTW REDUCTION GEAR WEIGHT ANALYSIS

1 Of 2

PART NO.	NAME	QUAN.	TOTAL WEIGHT	
			kg	lb
675D4	Bolt	32	0.450	0.992
764D107	Bolt	18	0.130	0.286
2067D960	Washer	18	0.022	0.049
AN960C416L	Washer	6	0.004	0.008
MS9388-011	Packing	8	0.001	0.002
MS9388-022	Packing	3	0.001	0.003
MS9388-023	Packing	8	0.004	0.008
MS9388-029	Packing	8	0.005	0.011
MS9388-280	Packing	1	0.022	0.048
MS9557-09	Bolt	4	0.114	0.252
MS9557-12	Bolt	6	0.046	0.102
185140	Coupling	1	2.75	6.07
185146	Ring	1	0.337	0.742
185153	Nut	32	0.125	0.275
185159	Gear and Bearing	8	37.26	82.14
185160	Spray Tube	8	0.28	0.61
185161	Sleeve	6	0.330	0.728
185163	Ring	8	0.139	0.306
185164	Nut	8	2.08	4.58
185165	Gear, Ring	1	12.42	27.38
185167	Ring	1	0.023	0.051
185168	Ring, Retaining	8	0.065	0.143
185169	Ring, Retaining	8	0.028	0.062
185225	Sleeve	2	0.104	0.229
490639	Tube, Oil	1	0.144	0.317
490646	Gear Assembly	1	-	-
185143	Gear, Sun	1	8.07	17.80
185156	Locknut	4	0.013	0.028
490647	Manifold Assembly	1	-	-

APPENDIX - D
 OTW REDUCTION GEAR WEIGHT ANALYSIS (Continued)

PART NO.	NAME	QUAN.	TOTAL WEIGHT	
			kg	lb
1039D2	Bushing	22	0.110	0.242
185166	Manifold	1	1.80	3.97
490648	Support Assembly	1	-	-
185156	Locknut	6	0.021	0.046
185170	Support	1	<u>23.00</u>	<u>50.70</u>
	TOTAL		89.89	198.18

ORIGINAL PAGE IS
 OF POOR QUALITY

APPENDIX E
MISES CRITERION

Mises Criterion

The following mathematical expression was proposed by R. van Mises as representing a criterion of failure by yielding.

$$\sigma_y = \sqrt{\frac{(\sigma_1 - \sigma_2)^2 + (\sigma_2 - \sigma_3)^2 + (\sigma_1 - \sigma_3)^2}{2}}$$

Where σ_1 , σ_2 and σ_3 = Principal Stresses

σ_y = Minimum Yield Value of Material at Temperature
(Uniaxially loaded bar)

If $\sigma_3 = 0$

$$\sigma_y = \sqrt{\sigma_1^2 - \sigma_1 \sigma_2 + \sigma_2^2}$$

This relationship is shown by the dashed ellipse below where $OB = \sigma_y$ in this case.

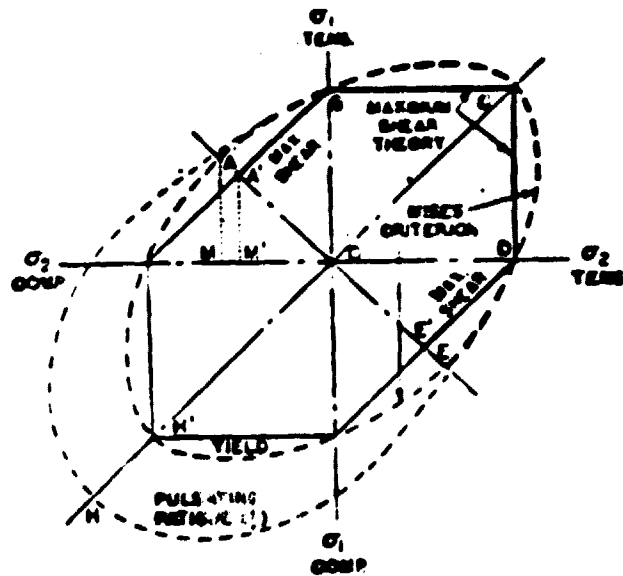

BI-AXIAL CONDITIONS FOR STRENGTH THEORIES
FOR DUCTILE MATERIALS.

Yield tests of ductile materials have shown that the Mises criterion interprets well the results of a variety of biaxial conditions. There is evidence that for ductile materials the Mises criterion also give a reasonably good interpretation of fatigue results in the upper right half of A B C D E of the ellipse for completely alternating or pulsating tension cycling.

The criterion states that yielding occurs when

$$\sigma_{EFF} = \sqrt{\sigma_1^2 - \sigma_1 \sigma_2 + \sigma_2^2} \geq \sigma_y$$

where σ_{EFF} = Effective Stress

The stress analysis approach used by Cortiss-Wright consists of the following four steps.

Step 1) Find Stresses σ_x , σ_y , τ_{xy}

Step 2) Find principal stresses using Mohr circle of the following expressions

$$\left. \begin{array}{l} \sigma_1 \\ \sigma_2 \end{array} \right\} = \frac{\sigma_x + \sigma_y}{2} \pm \frac{1}{2} \sqrt{(\sigma_x - \sigma_y)^2 + 4\tau_{xy}^2}$$

Step 3) Find the Effective Stress

Step 4) Compare it with the allowable

Ref.: "Stress Concentration Design Factors" by R. E. Peterson 5th Printing
Page 6.

Also: "Advanced Mechanics of Materials" by B. Seely and O. Smith 2nd Edition
Page 81.