



NASA Technical Memorandum 80197

NASA-TM-80197 19800007614

A STUDY OF PARTIAL COHERENCE FOR IDENTIFYING
INTERIOR NOISE SOURCES AND PATHS ON GENERAL
AVIATION AIRCRAFT

JAMES T. HOWLETT

FOR REFERENCE

NOT TO BE TAKEN FROM THIS ROOM

DECEMBER 1979

[Faint, illegible stamp or handwritten text]



National Aeronautics and
Space Administration

Langley Research Center
Hampton, Virginia 23665

A STUDY OF PARTIAL COHERENCE FOR IDENTIFYING INTERIOR NOISE SOURCES
AND PATHS ON GENERAL AVIATION AIRCRAFT

James T. Howlett
NASA Langley Research Center
Hampton, Virginia

SUMMARY

This paper describes the initial results of an effort to develop partial coherence techniques for interior noise source/path determination in the highly coherent environment of propeller-driven general aviation aircraft. Examples illustrate the effects of measurement interference and the use of a two-channel, real-time analyzer for the analysis. The paper includes a summary of the computational techniques and illustrates their application to a two input, single output system with coherence between the inputs. Errors introduced into the calculations by the method used for data analysis are discussed. The results illustrate the importance of using a simultaneous time base for the data reduction and indicate the type of errors that can be encountered by failure to observe this requirement.

N80-15874*

INTRODUCTION

Effective procedures for controlling interior noise require identification of the noise sources and the noise transmission paths. Current methods for accomplishing this are cumbersome and time consuming. The difficulties encountered are particularly evident in the highly coherent environment of a propeller-driven general aviation aircraft. A new technique for efficient, reliable determination of noise sources and paths along with the capability to rank order their importance is needed.

Recent developments in computational procedures have led to increased interest in partial coherence analyses for source/path determination. The theoretical aspects of this method as developed by Dodds and Robson (ref. 1) and further improved by Bendat (refs. 2, 3, 4) are particularly appropriate for this investigation. Applications of these methods to diesel engines (refs. 5, 6), a punch press (ref. 7), and a light aircraft (ref. 8) have been reported in the literature. However, these previous authors reported only partial success in identifying sources. Improvements of the approach are felt to be needed before the method can be successfully applied to interior noise problems encountered in propeller-driven general aviation aircraft.

The purpose of this paper is to describe the latest results of an ongoing effort to develop partial coherence techniques for interior noise source/path determination in the highly coherent environment of propeller-driven general aviation aircraft. The paper includes a summary of the theoretical method as developed by Bendat (ref. 2) and illustrates the application to a two input, single output system with coherence between the inputs. The augmentation of the calculations on a digital computer interfaced with a two-channel real-time analyzer is discussed. The results presented indicate possible sources of error in the computations and suggest procedures for avoiding these errors.

DESCRIPTION OF ANALYSIS

A schematic indicating the analytical model of a physical system used in partial coherence analyses is shown in figure 1. The physical inputs consists of a number of time histories which have been directly measured on the physical system under consideration and are assumed to represent the various sources of interior noise. There may be various degrees of coherence between these input records as well as between each of them and the output record which has been directly measured also and is assumed to represent the interior noise environment (receiver). It is assumed that none of these coherences are identically one. If this occurs, the records contain redundant (or unnecessary) information and some of the records should be eliminated from the analysis (ref. 2). After the redundant records are eliminated, the remaining input records are ordered. Although the selection of the order of these records is largely arbitrary, one procedure is to choose the record with the highest coherence between the input and output as the first ordered input; the record with the next highest coherence is chosen as the second ordered input, and so forth.

Once the ordered inputs have been obtained, the rest of the analysis is usually carried out in the frequency domain. Conceptually, however, the process is equivalent to obtaining conditioned inputs in the time domain. The first conditioned input is identical to the first ordered input. The second conditioned input, $x_{2,1}(t)$, is the second ordered input with the effects of $x_1(t)$ removed. The third conditioned input, $x_{3,12}(t)$, is the third ordered input with the effects of $x_1(t)$ and $x_2(t)$ removed, and so on. The conditioned inputs are then mutually uncoherent. Each conditioned input record is assumed to be the input signal to an ordered transfer function which relates that particular conditioned input record to the output. The ordered transfer functions are not unique, but depend upon the particular order used for the ordered inputs. Equations relating the physical transfer functions to the ordered transfer functions may be found in reference 3. The relative effect of each ordered input on the output is given by an equation of the form $S_{yy} = |H|^2 S_{xx}$ (ref. 4).

As previously stated, the analysis is usually carried out in the frequency domain. The first step is the calculation of the auto-spectra and cross-spectra for all possible combinations of the ordered inputs and the output. After these spectral functions have been calculated, the effects of the inputs are removed from the spectra. The formulas for removing the effect of input k from the auto-spectra and cross-spectra are shown in figure 2. As indicated in the figure, the equation for $S_{ij \cdot k}$ (auto-spectrum of ordered input i with the effect of input k removed) has two forms. The form of this equation which explicitly involves the coherence function, γ_{ik}^2 , clearly demonstrates that $S_{ij \cdot k} \geq 0$ since $\gamma_{ik}^2 \leq 1$. However, the other form of this equation involves multiplications, divisions, and subtractions of three different spectra and it is entirely possible that small, statistically insignificant differences in the estimates of these spectra could result in the computation of negative numbers. The formula for $S_{ij \cdot k}$ (cross-spectrum between ordered inputs i and j with the effect of input k removed) involves four different spectra and is also subject to the kinds of errors just mentioned. The formulas for removing the effects of more than one input are similar and may be found in the literature, e.g., reference 2.

Also shown in figure 2 is the partial coherence function $\gamma_{iy \cdot k}^2$ (partial coherence between ordered input i and the output with the effect of input k removed). Note that partial coherence is simply ordinary coherence computed using conditioned spectra and may be used to rank order the importance of the inputs. That is, it follows from the formula for the output due to ordered input i with the effect of input k removed (fig. 2) that $\gamma_{iy \cdot k}^2 < \gamma_{jy \cdot k}^2$ implies ordered input j produces a greater part of the output signal than ordered input i (with input k removed).

RESULTS AND DISCUSSION

Source Measurement Interference

The problem of source measurement interference provides a typical application for partial coherence techniques. The analytical model for this problem is shown in figure 3. The two sources of noise are assumed to be uncoherent. Two microphones, M_1 and M_2 , are used to measure the noise sources but because of measurement interference, the quantities actually measured are $M_1: S_{11} + k_1 S_{22}$ and $M_2: S_{22} + k_2 S_{11}$, where the parameters k_1, k_2 determine the coherence between the input measurements. For the numerical example presented herein, the coherence between the input measurements is $\gamma_{12}^2 = 0.7$. An analytical transfer function is specified between each of the source inputs and the output. The auto-spectra shown in figure 3, along with the various cross-spectra, were used in the computational algorithms to compute the partial coherence functions between M_1, M_2 , and the output, and estimate the previously specified transfer functions. Figure 4 shows plots of two of the coherence functions for this test case. The ordinary coherence function between input 1 and the output is nearly equal to 1 for frequencies up to 500 Hz and drops to a value of about 0.8 for frequencies between 700 Hz and 1000 Hz. The partial coherence function between input 1 and the output with the effect of input 2 removed is identically 1. This value is correct since, after the effects of input 2 are removed, the model consists of a single input, single output, linear system.

Figure 5 shows a comparison of the exact and estimated transfer functions for the test case. The first resonant peak of H_{1y} at 400 Hz is determined reasonably well by the estimated transfer function. The frequency of the second resonant peak of H_{1y} at 700 Hz is also determined accurately but the amplitude of the transfer function is somewhat overestimated at this frequency. For H_{2y} , the resonant peak at 400 Hz is also determined quite well by the estimated transfer function. However, at 700 Hz the estimated function indicates a low amplitude resonant peak which is not present in the exact expression for H_{2y} . The presence of this peak in the estimated transfer function is due partly to the coherence which exists between the inputs, M_1 and M_2 , and partly to the difference between ordered transfer functions and physical transfer functions. This result indicates that care must be exercised in inferring the existence of resonant responses from a partial coherence analysis using experimental data for which measurement interference may exist, and for which the actual resonances are unknown. Although the amplitudes of the estimated transfer functions are somewhat in error, these transfer functions do correctly indicate the relative importance of the two inputs in this example.

Experiment Using Computer-Analyzer Interface

In this test case, the use of a hard-wired, two-channel analyzer was investigated. A set of experimental data was obtained by simultaneously recording the output of a white noise generator on three channels of a tape recorder. These data were considered as a two input, single output system with transfer functions of unity between each of the input signals and the output. The data were analyzed on a desk top computer which was interfaced with a two-channel analyzer using the IEEE bus. This interface was straightforward and presented no particular problems. However, the use of a two-channel analyzer does have implications on the subsequent data analysis. This system dictated that only three spectra could be obtained simultaneously: two auto-spectra and the cross-spectrum. Thus, several passes of the data were required to obtain the necessary spectra. Since it was impossible with the equipment available to start the data analysis at precisely the same spot on the analog tape every time, the actual spectra used in the analysis were obtained from slightly different time segments. This was found to adversely affect the accuracy of the results specifically in that values of coherence much greater than 1 were computed. As a measure of this accuracy loss, the ordinary coherence functions have been recomputed using the spectra stored in the computer and compared with the coherence functions from the two-channel analyzer which were obtained as the data were processed. It is felt that any additional results obtained by further processing of this data will be no more accurate than these recomputed coherence functions.

Figure 6 shows several examples of these recomputed ordinary coherence functions. As indicated in figure 6(a), γ_{12}^2 which was recomputed using three spectra obtained simultaneously, displays the characteristics expected for these coherence functions. Its value is very nearly 1 over most of the frequency range. All of the coherence functions for this case should appear virtually identical to the coherence function γ_{12}^2 shown in this figure, if the computations are accurate.

The coherence function γ_{1y}^2 shown in figure 6(a), which was recomputed with only two spectra obtained simultaneously, indicates errors of about ± 10 percent (compared with γ_{12}^2). Some of the values are greater than 1 and could lead to the computation of negative values for the conditioned auto-spectrum. (See figure 2.) The coherence function γ_{2y}^2 recomputed with none of the spectra from simultaneous time segments, shows large deviations (± 30 percent) from the true value. Errors of this magnitude obviate the usefulness of coherence analyses.

Figures 6(b) and 6(c) show the effects of increasing the number of averages (figure 6(b)) and increasing the bandwidth of the analysis (figure 6(c)) for a recomputed coherence function with two spectra obtained simultaneously. As these figures indicate, increasing either the number of averages or the bandwidth of the analysis does have a smoothing effect on the recomputed coherence functions. However, the amount of data available for analysis or

the frequency resolution required to separate different sources may easily make either of these approaches unfeasible.

An error analysis was conducted to determine the source of the loss of accuracy. Standard error formulas were used to obtain 95 percent confidence intervals for the individual spectra (ref. 4). The worst combinations of the numbers so obtained were then used in the equation for calculating coherence functions to obtain the actual errors. The results of this analysis are shown in figure 7. The solid curve in figure 7 shows the percentage of the error (which may be plus or minus) versus the number of averages for data with two spectra obtained simultaneously. The dashed curve shows the error for data with none of the spectra obtained simultaneously. Also shown on figure 7 are experimental results for two spectra obtained simultaneously (circles) and none of the spectra obtained simultaneously (squares). As the figure shows, the experimental results are in good agreement with this error analysis.

Although the data analysis can be accomplished using a two-channel analyzer with no fewer than two spectra obtained simultaneously, such an approach would require reanalyzing the same data several times. This fact, together with the large number of averages required to maintain reasonably small errors (say 10 percent), suggests that alternative methods of analysis, such as simultaneous digitizing of all data, would be preferred. In addition, the results of this study indicate that the calculations which must be performed in a partial coherence analysis are quite sensitive to such parameters as the number of averages and the bandwidth of the analysis.

CONCLUDING REMARKS

This paper has described the initial results of an effort to develop partial coherence techniques for interior noise source/path determination in the highly coherent environment of propeller-driven general aviation aircraft. Examples are shown to illustrate the effects of measurement interference and the use of a two-channel, real-time analyzer to obtain the initial spectra required for the analysis. Use of the two-channel analyzer system illustrates the importance of obtaining all of the necessary spectra from simultaneous time segments. Failure to observe this requirement introduces errors of up to ± 30 percent into the computations. Such errors may result in computed coherences much larger than 1. Results were presented showing that these errors could be reduced by using a large number of averages, up to 2000, in obtaining the spectral estimates. Because such a large number of averages is difficult or impossible to obtain in practical experimental situations, alternative methods of analysis, such as the simultaneous digitizing of all data, are preferred.

An analytical example of the measurement interference problem has also been presented. The results indicate that the estimated transfer functions can be used to determine the relative importance of the noise source inputs.

REFERENCES

1. Dodds, C. J.; and Robson, J. D.: Partial Coherence in Multivariate Random Processes, *J. Sound and Vibration*, 42(2), pp. 243-249, September 1975.
2. Bendat, J. S.: Solutions for the Multiple Input/Output Problem. *J. Sound and Vibration*, 44(3), pp. 311-324, February 1976.
3. Bendat, J. S.: System Identification from Multiple Input/Output Data. *J. Sound and Vibration*, 49(3), pp. 293-308, December 1976.
4. Bendat, J. S.: Statistical Errors in Measurement of Coherence Functions and Input/Output Quantities. *J. Sound and Vibration*, 59(3), pp. 405-421, August 1978.
5. Chung, J. Y.; Crocker, M. J.; and Hamilton, J. F.: Measurement of Frequency Responses and the Multiple Coherence Function of the Noise-Generation System of a Diesel Engine. *J. Acoustical Society of America*, Vol. 58, No. 3, pp. 635-642, September 1975.
6. Alfredson, R. J.: The Partial Coherence Technique for Source Identification on a Diesel Engine. *J. Sound and Vibration*, 55(4), pp. 487-494, December 1977.
7. Koss, L. L.; and Alfredson, R. J.: Identification of Transient Sound Sources on a Punch Press. *J. Sound and Vibration*, 34(1), pp. 11-13, May 1974.
8. Keefe, Laurence: Interior Noise Path Identification in Light Aircraft Using Multivariate Spectral Analysis. AIAA Paper No. 79-0644, 5th Aeroacoustics Conference, Seattle, Washington, March 1979.

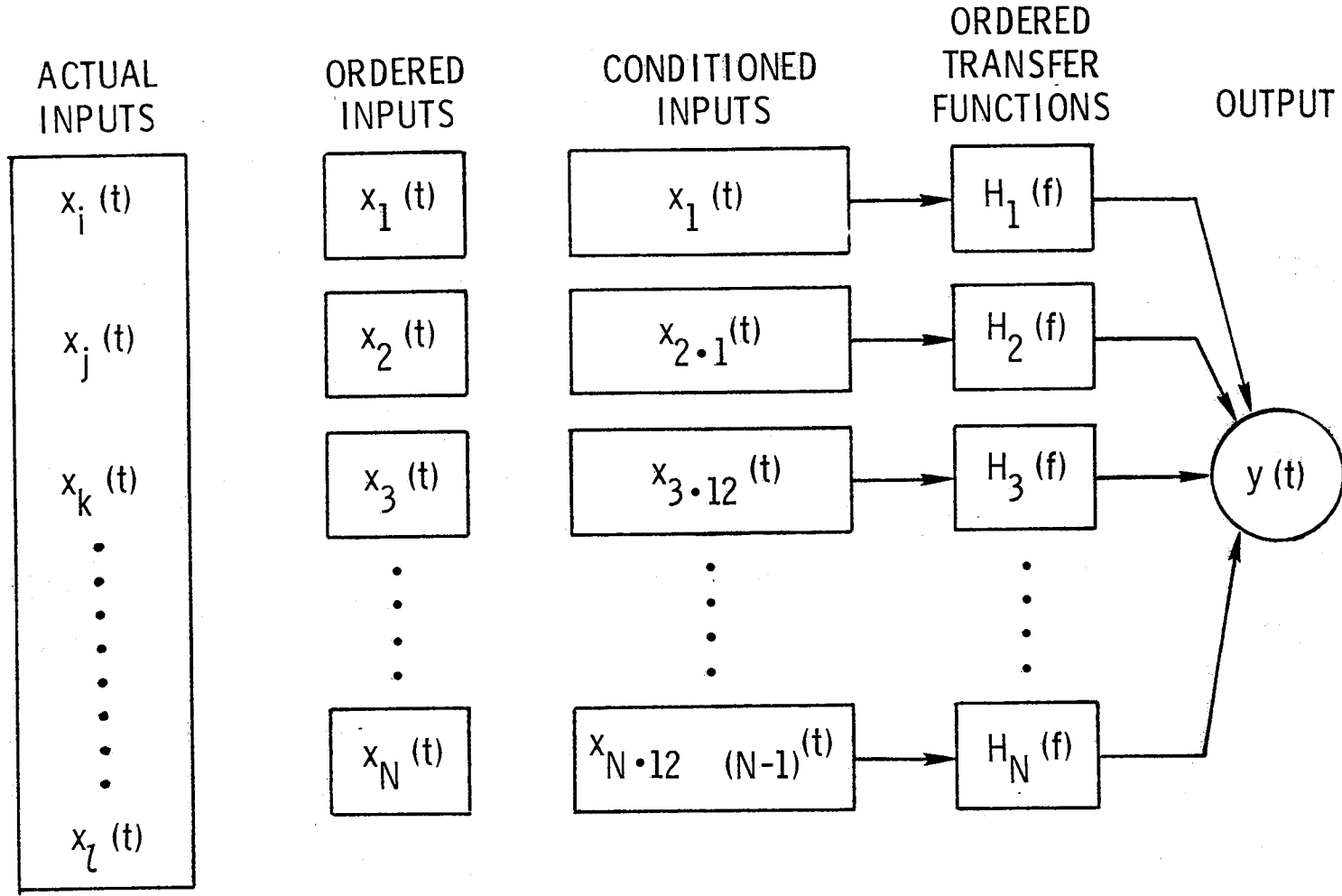

Figure 1.- Schematic of partial coherence analytical model for multiple input system.

$S_{ij \cdot k}$ = CROSS-SPECTRUM FOR ORDERED INPUTS i AND j WITH EFFECT OF INPUT k REMOVED

$$S_{ii \cdot k} = S_{ii} - \frac{S_{ik} S_{ki}}{S_{kk}} = (1 - \gamma_{ik}^2) S_{ii}$$

$$S_{ij \cdot k} = S_{ij} - \frac{S_{ik} S_{kj}}{S_{kk}}$$

$\gamma_{iy \cdot k}^2$ = PARTIAL COHERENCE FUNCTION BETWEEN ORDERED INPUT i AND OUTPUT WITH EFFECT OF INPUT k REMOVED

$$\gamma_{iy \cdot k}^2 = \frac{|S_{iy \cdot k}|^2}{S_{ii \cdot k} S_{yy \cdot k}}$$

$\gamma_{iy \cdot k}^2 S_{yy \cdot k}$ = OUTPUT DUE TO ORDERED INPUT i WITH INPUT k REMOVED

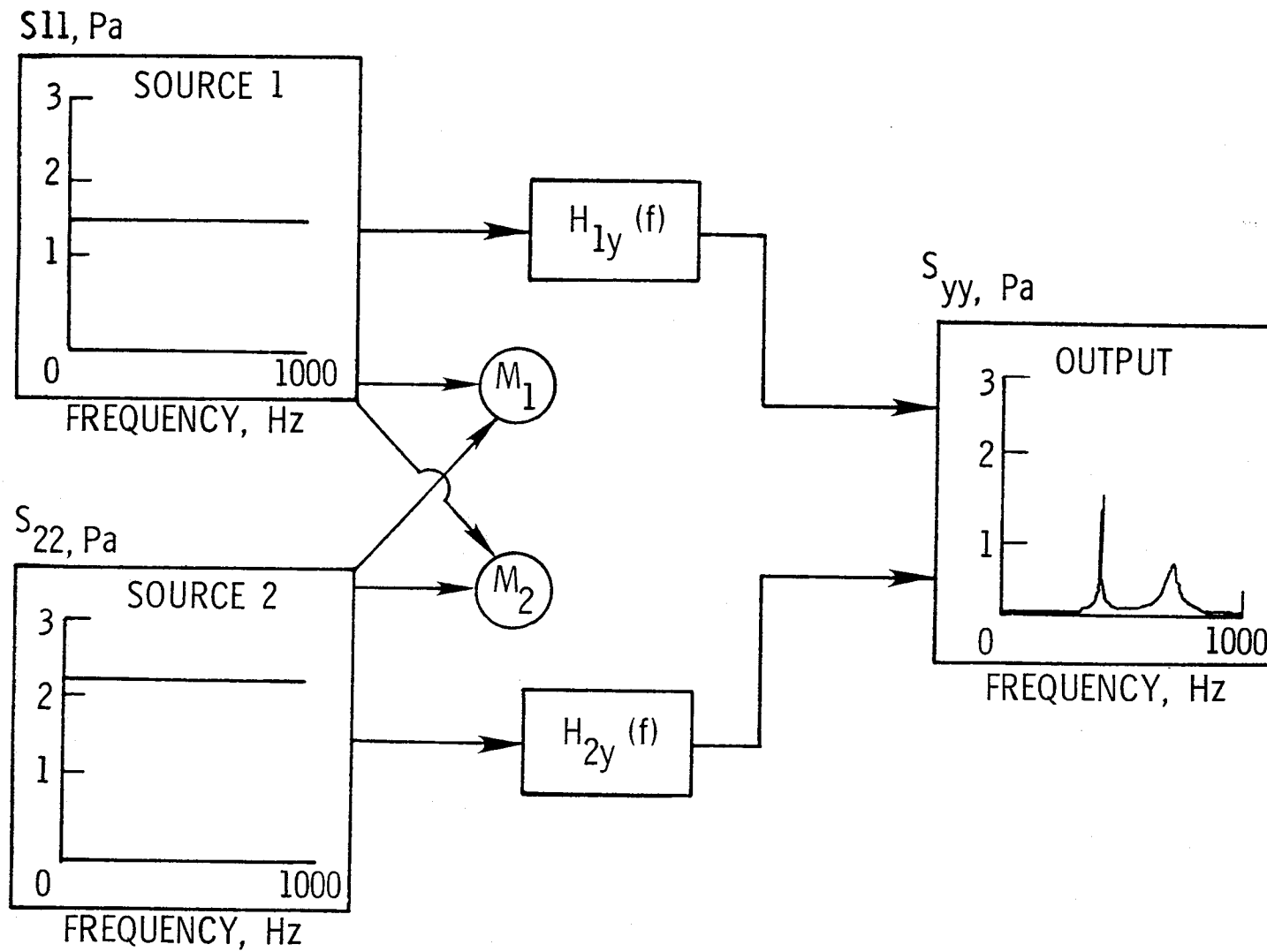

Figure 3.- Analytical model for source measurement interference.

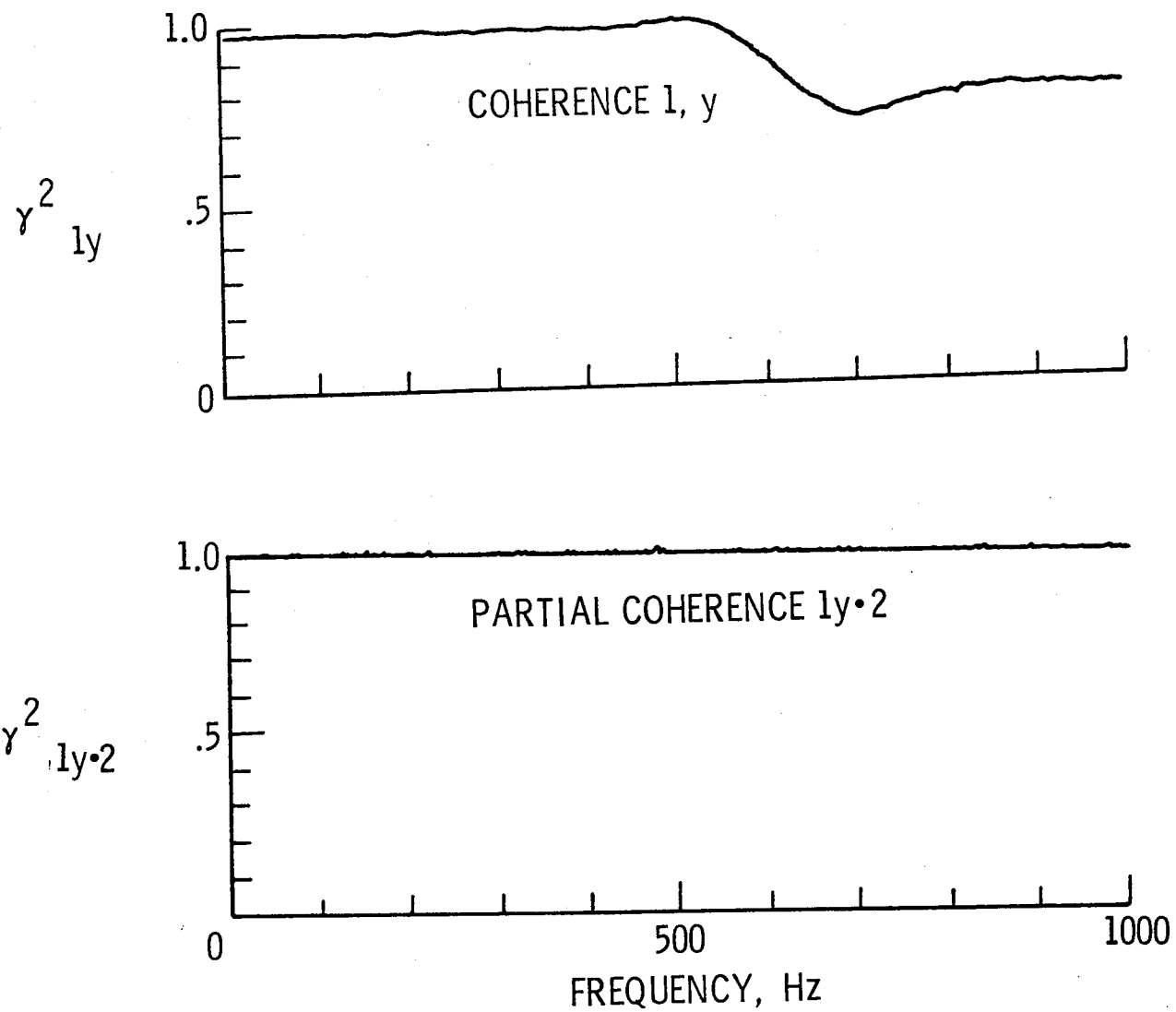

Figure 4.- Coherence functions for source measurement interference problem.

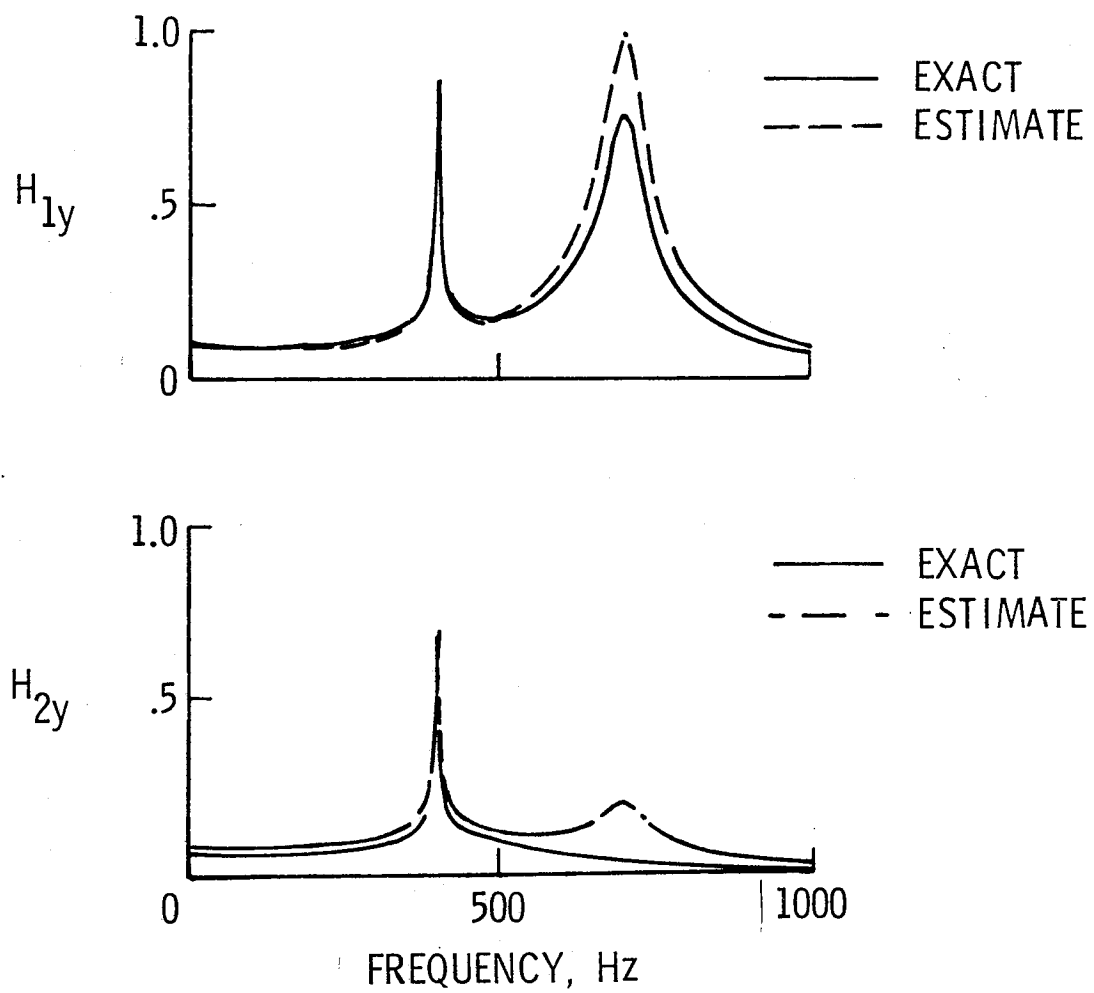
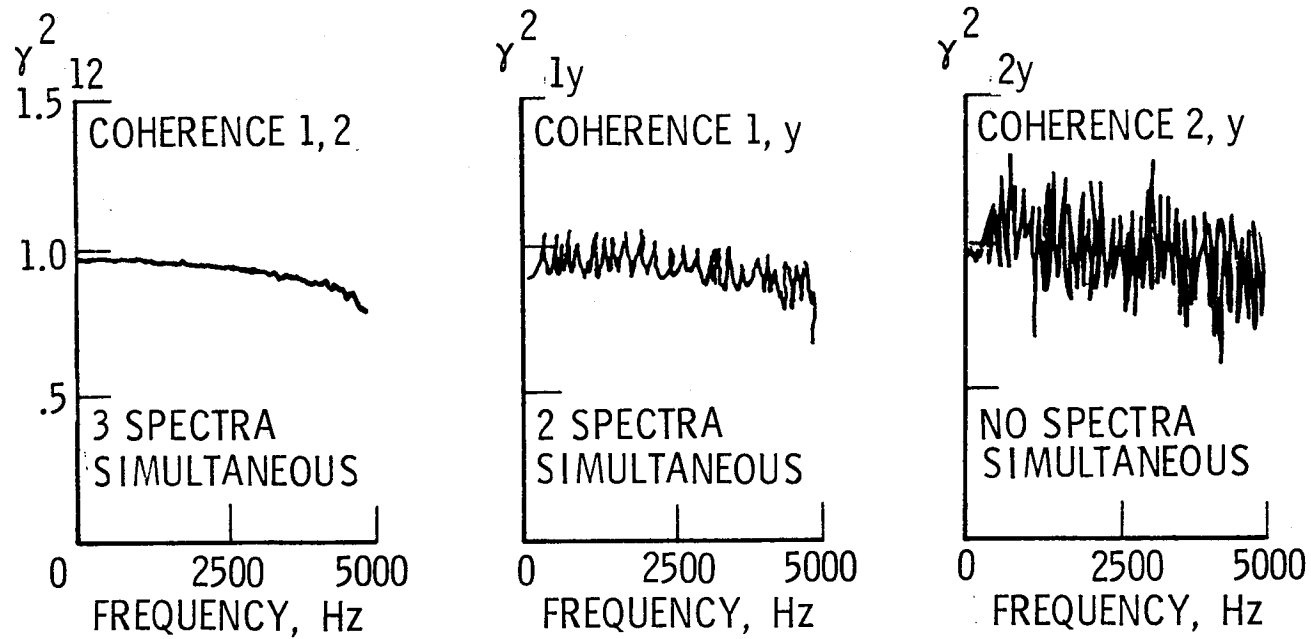
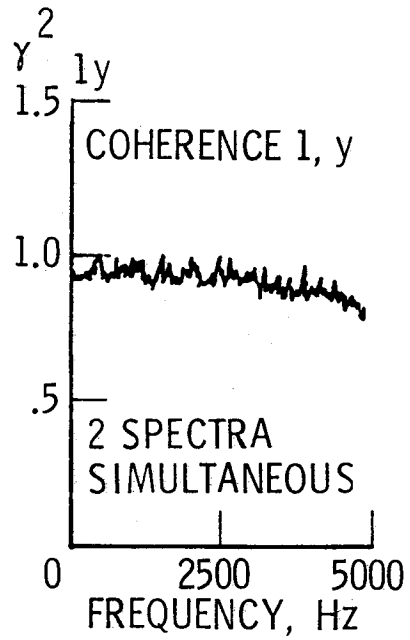

Figure 5.- Transfer functions for source measurement interference problem.



(a) 500 AVERAGES, 2.5 Hz BANDWIDTH



(b) 2000 AVERAGES, 12.5 Hz BANDWIDTH

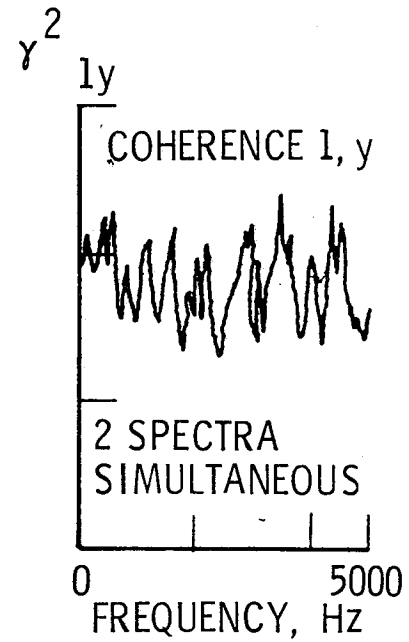

(c) 100 AVERAGES, 50 Hz BANDWIDTH

Figure 6.- Concluded.

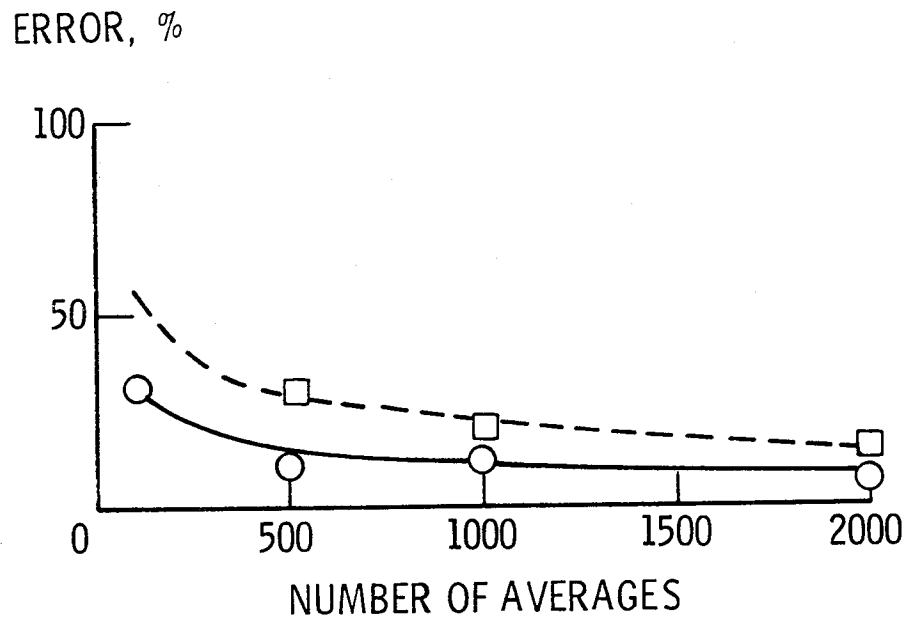

ANAL.	EXP.	
---	□	NONE SIMUL.
—	○	2 SIMUL.

Figure 7.- Error due to nonsimultaneous spectra.

1. Report No. NASA TM-80197		2. Government Accession No.		3. Recipient's Catalog No.	
4. Title and Subtitle A STUDY OF PARTIAL COHERENCE FOR IDENTIFYING INTERIOR NOISE SOURCES AND PATHS ON GENERAL AVIATION AIRCRAFT				5. Report Date December 1979	
				6. Performing Organization Code	
7. Author(s) James T. Howlett				8. Performing Organization Report No.	
9. Performing Organization Name and Address NASA Langley Research Center Hampton, Virginia 23665				10. Work Unit No. 505-33-53-03	
				11. Contract or Grant No.	
12. Sponsoring Agency Name and Address National Aeronautics and Space Administration Washington, DC 20546				13. Type of Report and Period Covered Technical Memorandum	
				14. Army Project No.	
15. Supplementary Notes Paper presented at the 98th Acoustical Society of America Meeting, Salt Lake City, Utah, November 26-30, 1979.					
16. Abstract Effective interior noise control procedures require identification of the noise sources and the noise transmission paths. Recent developments in computational procedures have led to increased interest in partial coherence analyses for source/path determination. However, the practical application of partial coherence techniques is not straightforward and an improved understanding of the approach is needed. This paper describes the latest results of an ongoing effort to use partial coherence for interior noise source/path determination. The paper includes a summary of the computational techniques as developed by Bendat (J. Sound & Vib., 49(3), 1976, pp. 293-308) and illustrates their practical application. A numerical example is included to illustrate one difficulty in applying partial coherence and a suggestion for circumventing this difficulty is offered. The augmentation of the calculations on a digital computer interfaced with a two-channel real-time analyzer is also discussed.					
17. Key Words (Suggested by Author(s)) Interior noise control procedures, Noise sources, Noise transmission paths, Partial coherence analyses			18. Distribution Statement Unclassified - Unlimited Subject Category 71		
19. Security Classif. (of this report) Unclassified		20. Security Classif. (of this page) Unclassified		21. No. of Pages 15	22. Price* \$4.00

