



3 1176 00138 6581

DOE/NASA/1060-79/3
NASA TM-79322

NASA-TM-79322 19800008230

POTENTIAL PERFORMANCE IMPROVEMENT USING A REACTING GAS (NITROGEN TETROXIDE) AS THE WORKING FLUID IN A CLOSED BRAYTON CYCLE

Robert J. Stochl
National Aeronautics and Space Administration
Lewis Research Center

December 1979

Prepared for
U.S. DEPARTMENT OF ENERGY
Energy Technology
Central Solar Technology Division



NF00535

NOTICE

This report was prepared to document work sponsored by the United States Government. Neither the United States nor its agent, the United States Department of Energy, nor any Federal employees, nor any of their contractors, subcontractors or their employees, makes any warranty, express or implied, or assumes any legal liability or responsibility for the accuracy, completeness, or usefulness of any information, apparatus, product or process disclosed, or represents that its use would not infringe privately owned rights

1 Report No NASA TM-79322	2 Government Accession No	3 Recipient's Catalog No	
4 Title and Subtitle POTENTIAL PERFORMANCE IMPROVEMENT BY USING A REACTING GAS (NITROGEN TETROXIDE) AS THE WORKING FLUID IN A CLOSED BRAYTON CYCLE		5 Report Date December 1979	6 Performing Organization Code
		8 Performing Organization Report No E-278	10 Work Unit No
7 Author(s) Robert J Stochl		11 Contract or Grant No	13 Type of Report and Period Covered Technical Memorandum
9 Performing Organization Name and Address National Aeronautics and Space Administration Lewis Research Center Cleveland, Ohio 44135		14 Sponsoring Agency Code Report No. DOE/NASA/1060-79/3	
		12 Sponsoring Agency Name and Address U S Department of Energy Central Solar Technology Division Washington, D.C 20545	
15 Supplementary Notes Final report. Prepared under Interagency Agreement EX-76-A-29-1060			
16 Abstract <p>The results of an analysis to estimate the performance that could be obtained by using a chemically reacting gas (nitrogen tetroxide) as the working fluid in a closed Brayton cycle are presented. Compared with data for helium as the working fluid, these results indicate efficiency improvements from 4 to 90 percent, depending on turbine inlet temperature, pressures, and gas residence time in heat-transfer equipment.</p>			
17 Key Words (Suggested by Author(s)) Brayton cycle Gas turbine Dissociating gas		18 Distribution Statement Unclassified - unlimited STAR Category 44 DOE Category UC-62B	
19 Security Classif (of this report) Unclassified	20 Security Classif (of this page) Unclassified	21 No of Pages	22 Price*

DOE/NASA/1060-79/3
NASA TM-79322

POTENTIAL PERFORMANCE
IMPROVEMENT USING A REACTING
GAS (NITROGEN TETROXIDE) AS
THE WORKING FLUID IN A
CLOSED BRAYTON CYCLE

Robert J. Stochl
National Aeronautics and Space Administration
Lewis Research Center
Cleveland, Ohio 44135

December 1979

Work performed for
U. S. DEPARTMENT OF ENERGY
Energy Technology
Central Solar Technology Division
Washington, D. C. 20545
Under Interagency Agreement EX-76-A-29-1060

NSA-16490 #

POTENTIAL PERFORMANCE IMPROVEMENT BY USING A REACTING GAS (NITROGEN
TETROXIDE) AS THE WORKING FLUID IN A CLOSED BRAYTON CYCLE

by Robert J. Stochl

SUMMARY

The results of an analysis to estimate the performance that could be obtained by using a chemically reacting gas (nitrogen tetroxide) as the working fluid in a closed Brayton cycle are presented. Compared with data for helium as the working fluid, these results indicate efficiency improvements from 4 to 90 percent, depending on turbine inlet temperature, pressures, and gas residence time in heat-transfer equipment.

E-278

INTRODUCTION

A concept for improving the efficiency of a closed Brayton cycle is based on the use of a particular working fluid that dissociates upon being heated to the turbine inlet temperature and returns to its initial recombined state upon being cooled to the compressor inlet temperature. If the dissociation and recombination rates are sufficiently high in the appropriate temperature and pressure range, the gas constant for the turbine would be larger than that for the compressor. This variation in the gas constant could result in an increase in net work output and, therefore, in increased efficiency over those for a cycle having constant gas properties. Such a concept could be attractive for solar thermal power applications, where high thermal efficiency is desirable because of the high cost of the collector-receiver system. A Brayton cycle using a reacting gas might yield higher efficiency, without increasing the turbine inlet and receiver temperatures and thus without incurring the associated higher cost.

The performance gains of such a cycle over a conventional closed Brayton cycle depend heavily on the kinetics of the reactions involved. If the appropriate reactions (dissociation and recombination) were not proceeding at a sufficient rate, the difference in the gas constant between the turbine and the compressor would not be great enough to achieve significant efficiency gain. This kinetic consideration presents a formidable problem in the analysis and design of such a cycle. The design of reacting-gas cycles also involves other considerations such as material compatibility and toxicity problems.

The purpose of this report is to quantify the potential performance improvement of a recuperated closed gas turbine cycle using nitrogen tetroxide (N_2O_4) as the reactive working fluid. This fluid was selected because it fulfills the requirements previously stated, because it is available, and because its thermodynamic properties are well documented. The performance is presented for turbine inlet temperatures of 1000° , 1200° , and 1500° F and compressor pressure ratios of 2.0, 3.0, 5.0, 7.0, and 10.0. The results are compared with those obtained by using helium as the working fluid over the same parametric range. Also discussed in this report

are the kinetics of the N_2O_4 reaction and their effect on the system performance.

Reacting-gas cycles have been considered previously. Known analytical and experimental work on reacting-gas cycles is briefly summarized in the next section.

LITERATURE REVIEW

Some time in the early 1960's, the Russians indicated strong interest in reacting gases. Between 1963 and 1968, extensive research was done on the thermodynamic and transport properties of reacting (dissociating) gases as well as on the application of those fluids as heat-transfer media and working fluids in power systems. A series of papers on the results of these investigations was presented at the all-Union Conference in January 1969. In one of these papers (ref. 1), V. B. Nesterenko discusses the advantages of using N_2O_4 in both Brayton and Rankine cycles. For the Brayton cycle, he compares the performance of helium and N_2O_4 for similar cycle conditions (turbine inlet temperatures between 1000° and 1560° F) and indicates cycle efficiencies as high as 40 to 48 percent for N_2O_4 , which is 8 to 12 percentage points higher than that of the inert-gas cycle. A special feature of the dissociating-gas cycle is the participation of the heat of chemical reaction, which results in more complete heat recuperation than in the inert-gas cycles. Nesterenko also indicates that the thermodynamic characteristics of N_2O_4 are superior to those of steam in a Rankine cycle. He calculates N_2O_4 Rankine cycle efficiencies 3 to 5 percentage points higher than those for steam (at maximum cycle temperatures of 500° to 1000° C and pressures of 130 to 240 atm). Another characteristic of N_2O_4 compared with steam is higher density at the turbine outlet, which allows the weight of the turbine to be reduced by a factor of 3 to 5. In the Nesterenko paper, there is no mention of any problems associated with the kinetics of the reactions.

The advantage of more complete heat recuperation obtained by using dissociating gas is also discussed in papers by Nesterenko (ref. 2) and Devonio (ref. 3). Their experimental results indicate that (1) heat-transfer rates achievable during the first stage of the N_2O_4 reaction ($N_2O_4 \rightleftharpoons 2NO_2$) are three to nine times higher than that of an inert gas, and (2) during the second stage ($2NO_2 \rightleftharpoons 2NO + O_2$), the heat transfer is considerably reduced, the extent depending on the residence time in the heat exchanger, but is still 1.5 to 2 times higher than that of inert gases. They also conclude that there is insufficient information available on the dissociation-recombination heat-transfer characteristics of N_2O_4 during the second-stage reaction at high temperatures and pressures. A paper by Gokhshtein et al. (ref. 4) reports studies conducted to ascertain the possibility of combining power generation with desalting of ocean water by using power installations with N_2O_4 as the working fluid. They conclude that the heating surface of the waste-heat exchanger for N_2O_4 is about 20 times less than that for nitrogen (N_2) since the coefficient of heat transfer is 10 to 15 times higher than that for either nitrogen or the products of combustion and there is an increase (about 1.7 times) in the mean temperature difference in the waste-heat exchanger.

The effect of kinetics of the chemical reaction $N_2O_4 \rightleftharpoons 2NO_2 \rightleftharpoons 2NO + O_2$ on the flow parameters during heating and cooling in channels is analyzed in a paper by Nesterenko et al. (ref. 2). They first assume that the first-stage reaction ($N_2O_4 \rightleftharpoons 2NO_2$) is in chemical equilibrium during all operational regimes. They then present results for the second-stage reaction which indicate considerable deviation from equilibrium conditions, depending on the residence time of the gas in the channel. Residence times of 4 seconds or greater (at a pressure of 1 atm) are required before equilibrium conditions are approached. They also indicate that more favorable reaction rates are obtained at higher pressures.

Corrosion stability of various construction materials in N_2O_4 under equilibrium conditions is the topic of two papers (refs. 5 and 6). The stability of carbon steels, stainless steels, aluminum alloys, and titanium alloys was determined at temperatures from 200° to 930° F and pressures from 20 to 50 atmospheres. The corrosion rate results quoted range from 0.73 g/m² hr for the low-carbon steels to 1×10^4 g/m² hr ($< 2.0 \times 10^{-4}$ mm/yr) for some of the stainless steels.

Turbines using N_2O_4 have been designed for power levels of 300 to 1000 megawatts by the Russians. From the comparisons given by Lomashev in his paper (ref. 7), it is apparent the N_2O_4 turbines are considerably smaller and lighter than steam turbines of the same power.

The only known significant United States works on dissociating gases as power cycle working fluids are (1) a paper by T. A. Jacob and J. R. Lloyd in June 1963 (ref. 8), (2) a paper by H. Cheung from the Lawrence Radiation Laboratories in March 1968 (ref. 9), and (3) a U.S. patent filed in October 1965 entitled "Thermal Dissociative Gas Power Conversion Cycle" (ref. 10).

Jacobs and Lloyd (ref. 8) considered, in general terms, the influence of a dissociating diatomic gas on Brayton cycle performance. They predicted a 40- to 160-percent increase in maximum thermal efficiency (depending on the cycle temperature ratio) compared with that for a cycle in which the specific heat is constant.

The results of reference 9 analytically showed that using phosphorus as a dissociating working fluid in a space Brayton cycle would require only one-third to one-fourth the radiator area required for an inert-gas working fluid.

The invention that was patented by K. P. Johnson (ref. 10) was the general idea of using a dissociating gas as a working fluid in a closed-cycle (Brayton, Stirling, or Rankine) power system. The objectives of this invention were to increase the cycle efficiency, reduce the complexity of a Rankine cycle powerplant, and provide a novel method of internally regenerating a closed-cycle powerplant. In his patent, Johnson indicated an increase in thermodynamic efficiency of 35 percent when N_2O_4 is used as the working fluid in a Brayton cycle compared with the efficiency when N_2 is used at a turbine inlet temperature of 1200° F.

DESCRIPTION OF CYCLE

The basic cycle configuration considered in this report is a recuperated closed gas turbine cycle using the reactive gas N_2O_4 as the working fluid. The basic reversible chemical reaction in this cycle is

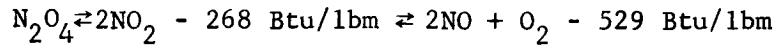

The first stage of the dissociation ($\text{N}_2\text{O}_4 \rightleftharpoons 2\text{NO}_2$) occurs mainly over the temperature range 70° to 340° F. The second stage ($2\text{NO}_2 \rightleftharpoons 2\text{NO} + \text{O}_2$) is significant in the temperature range 280° to 1600° F.

Figure 1 is a schematic of a typical configuration showing the temperature, pressure, and equilibrium composition at the cycle state points for a turbine inlet temperature of 1500° F and a compressor pressure ratio of 5.0. The gas with initially high molecular weight (lowest gas constant) is pressurized in the compressor and then heated first in a recuperator and second in a heat input heat exchanger to the maximum cycle temperature. During this process, the gas dissociates (absorbs the heat of chemical reaction), and the result is a decrease in molecular weight (increases in the number of moles and the gas constant to the maximum values in the cycle). As can be seen for the equilibrium conditions presented in figure 1, the first stage of the chemical dissociation ($\text{N}_2\text{O}_4 \rightleftharpoons 2\text{NO}_2$) is essentially completed in the recuperator. By the time the mixture reaches the turbine, the second stage of dissociation ($2\text{NO}_2 \rightleftharpoons 2\text{NO} + \text{O}_2$) is nearly complete. The gas is then expanded through the turbine and cooled in the recuperator and precooler. During the cooling process, the gas recombines (liberates heat), and the number of moles and the gas constant are decreased to the minimum values. The gas then enters the compressor, where the cycle is repeated.

EQUILIBRIUM RESULTS

The performance results presented first are based on the thermodynamic properties of the gas mixture in equilibrium undergoing the reactions $\text{N}_2\text{O}_4 \rightleftharpoons 2\text{NO}_2 \rightleftharpoons 2\text{NO} + \text{O}_2$. These properties at the various cycle state points were calculated by using the computer program developed in reference 11. The kinetic rates of these reactions are high enough so that the reactions are likely to closely approach equilibrium in the residence times normally encountered in power systems. Much slower reactions, such as the dissociation of the oxides of nitrogen into elemental nitrogen, were neglected. The analytical procedure used to calculate the various state points and resulting efficiencies is given in the appendix.

Also included is a discussion of the kinetics of the chemical reactions and the approach to the equilibrium conditions, together with an estimate of the effect on cycle performance.

The parametric variations and assumptions used in generating the performance results are shown in table I.

Figure 2 presents the gross thermodynamic efficiency of the reacting-gas cycle for three turbine inlet temperatures over a range of pressure ratios. Also shown for comparison purposes are the results for helium as the working fluid. The optimum efficiency for N_2O_4 is closely approached with a pressure ratio 5.0 for each of the three turbine inlet temperatures. The optimum efficiency for helium is obtained at a pressure ratio of approximately 2.0.

A comparison of the gross efficiency of the two working fluids at the pressure ratio that results in optimum efficiency is shown in figure 3.

Using the reacting gas results in a 90-percent increase in efficiency at a turbine inlet temperature of 1000° F and a 20-percent increase at 1500° F.

A major factor in this increased performance is the work parameter, the ratio of the net cycle work to the gross turbine work produced. Figure 4 shows a comparison of the work parameter for helium and N₂O₄ as a function of turbine inlet temperature. Only 18 to 38 percent of the gross turbine work is obtained in the form of useful work when helium is used as the working fluid compared with 67 to 77 percent when N₂O₄ is used. As mentioned previously, this large increase in net specific work is the result of an increased gas constant through the turbine compared with that in the compressor.

A comparison of the energy flow paths for helium and N₂O₄ in a 1500° F turbine, both at optimum pressure ratio, is shown schematically in figure 5. Both of these energy flow diagrams have been normalized with the energy input. This figure clearly illustrates the large reduction in that portion of the gross turbine output that is required to recompress the working fluid when N₂O₄ is used. For this particular comparison, only 22.4 percent of the turbine output is required for compression with N₂O₄, while 61.5 percent is required with helium as the working fluid. This difference again reflects the contribution of the varying gas constant.

There is also a benefit to be gained in recovering waste heat. In the N₂O₄ system, 74 percent of the energy leaving the turbine is returned to the cycle through recuperation compared with 69 percent in the helium system for the same minimum temperature difference in the recuperator. The greater amount of recuperation with the reacting gas is the result of two factors: (1) because of the lower specific heat ratio of N₂O₄, the expansion process is more isothermal, so that temperatures at the recuperator inlet are higher and, therefore, driving temperatures are higher; and (2) the release of the heat of chemical reaction during the recombination process contributes to more complete heat recuperation.

KINETIC RESULTS

As mentioned previously, the results presented thus far are based on properties obtained from equilibrium concentrations for the dissociation of N₂O₄ to NO at each particular cycle state point, that is, the properties are functions of temperature and pressure only, not time. How well these results would apply to real systems depends entirely on the kinetics of the N₂O₄ ⇌ 2NO₂ ⇌ 2NO + O₂ reaction.

The kinetics of this reaction, which are illustrated in figures 6 and 7, were obtained by using the computer code of reference 12. These results are based on the assumption that the gas initially at the equilibrium concentrations corresponding to the temperature and pressure at the compressor inlet is instantaneously heated to the turbine inlet temperature (1000° or 1500° F). This is a optimistic assumption, inasmuch as this situation would never be realized, but it indicates the minimum time requirements. The kinetics computer program calculates the mass and mole fractions of the initial and formed species as a function of time.

Figure 6 shows the calculated values of the relative concentrations at 1000° F as a function of time for initial concentrations (mole fractions) of 0.608 for N₂O₄ and 0.392 for NO₂. These initial concentrations correspond to equilibrium values at 98° F and 20.3 pounds per square inch absolute. The first stage of the dissociation (N₂O₄ ⇌ 2NO₂) is almost instantaneous compared with the times of interest. The second stage (2NO₂ ⇌ 2NO + O₂), for all practical purposes, does not begin until after a residence time of 2.0 seconds at 1000° F. It is apparent that, at 1000° F, the assumption of equilibrium for this reaction is questionable in a practical power cycle and that, while the N₂O₄ cycle would probably still be somewhat superior to the helium cycle, the thermodynamic performance improvement would not be as large as indicated in the previous discussion of figures 2 to 5.

Figure 7 shows the relative concentrations at 1500° F as a function of time for two pressures (5 and 20 atm). The first stage of the reaction is nearly instantaneous (<10⁻⁸ sec) for both pressures. At 5 atmospheres, the second stage of the reaction is approximately 50 percent complete at the end of 2.0 seconds, while, at 20 atmospheres, the second stage is approximately 90 percent complete at the end of 2.0 seconds. The mole fractions obtained in 2.0 seconds at 5 atmospheres could be achieved in 0.5 second at 20 atmospheres. From these results, it is evident that the validity of the performance values based on the equilibrium assumption is strongly dependent not only on temperature but also on pressure.

To include these effects in the performance analysis would be a formidable task beyond the scope of this effort. It not only would involve including chemical kinetics in the analysis but also would require physical sizing of all the components to determine residence times. However, an estimate of these effects on the performance of the cycle can be made by assuming that the first stage of the reaction (N₂O₄ ⇌ 2NO₂) is in equilibrium and that no dissociation occurs in the second stage. Figures 6 and 7 show that the first stage of the reaction is very rapid even at 1000° F and low pressures and, therefore, should indicate a possible minimum improvement in cycle performance for this reactive gas.

Figure 8 shows the cycle performance obtained by assuming that the working fluid is limited to the equilibrium conditions of the first-stage reaction. The performance values were calculated for turbine inlet temperatures of 1000° and 1500° F at a pressure ratio of 5.0. The results obtained by using N₂O₄ with the complete reaction and helium as the working fluids are the same as shown previously in figure 3. There is a 5- to 6-percentage-point penalty in performance (14- to 18-percent reduction in efficiency) depending on temperature when only first-stage dissociation is assumed rather than the equilibrium composition of both stages of the reaction. However, the first-stage reaction still results in a 54-percent increase at a turbine inlet temperature of 1000° F and a 4-percent increase at 1500° F compared with performance obtained by using helium. The performance obtained by considering the reaction kinetics would fall between the two curves shown in figure 8. As indicated in figures 6 and 7, the results obtained at 1000° F would be closer to the lower curve, and those obtained at 1500° F would be closer to the top curve. The closeness of the approach to the top curve depends on the residence time and on the degree of mixing achieved in the heat-transfer components of the power system.

The performance results just discussed assume that the initial equilibrium concentrations at the compressor inlet are maintained. If the compressor inlet conditions were allowed to vary, so too would the relative difference in gas constant between the turbine and the compressor. Constant compressor inlet conditions could be maintained by incorporating a relatively large holding tank into the system between the waste-heat exchanger and the compressor inlet. This tank could allow enough residence time for the mixture to recombine to its original condition.

The conclusion that can be drawn from the preceding comparison is that there are performance benefits to be gained by using reacting-gas cycles even for minimum residence times. An apparent means of increasing the reaction rate and thereby increasing cycle efficiency would be to raise the system pressure level and/or pressure ratio. Raising the pressure ratio from 5.0 to 10.0, while not appreciably affecting equilibrium system performance (see fig. 2), would somewhat improve the kinetics so that the system would approach the equilibrium conditions more rapidly.

The system pressure level and pressure ratio selected depend on the minimum cycle temperature at the compressor inlet. At a compressor inlet temperature of 86° F and pressure of 1 atmosphere, the pressure ratio should not exceed 5.0. Further pressure rise under these conditions would lead to operation of the last stages of the compressor in the two-phase region. If the minimum temperature were raised to 100° F, the pressure ratio could be increased to 100 before the two-phase region would be encountered in the compressor. The amount the compressor inlet temperature could be increased would be determined by a tradeoff between the performance gain due to more favorable reaction rates at the higher pressures and the possible lower performance due to the increased compressor work at the higher inlet temperature. In a solar application, the higher compressor inlet temperature might even be beneficial in that it could also reduce air-cooled waste-heat-exchanger requirements and, therefore, cost.

CONCLUDING REMARKS

With the assumption of equilibrium conditions in the dissociation of N_2O_4 to NO , the use of N_2O_4 as the working fluid in a closed gas turbine cycle results in a 20- to 90-percent performance improvement, for turbine inlet temperatures of 1000° to 1500° F, compared with using helium as the working fluid. These results agree with the ranges quoted in the literature; however, there is little detailed information available in the literature as to the assumptions or analytical approaches. These performance improvements are strongly dependent cycle temperature and pressures, which in turn affect reaction rates and system approach to equilibrium conditions. For example, at a turbine inlet temperature of 1000° F, the equilibrium assumption for the reaction $2NO_2 \rightleftharpoons 2NO + O_2$ is not valid for reasonable gas residence times in heat-exchange components. At 1000° F, only the first stage of the reaction can be considered to approach equilibrium at pressures up to 20 atmospheres. Even though the second stage of the dissociation reaction does not approach equilibrium conditions, there is still considerable improvement in performance (~50 percent) just from the dissociation of the first stage of the reaction. The kinetics

of the reaction improve with increasing temperature and pressure. At 1500° F and 20 atmospheres, the second stage of the dissociation reaction ($2\text{NO}_2 \rightleftharpoons 2\text{NO} + \text{O}_2$) reaches 90 percent of its equilibrium value in 2.0 seconds. It is expected that conditions near equilibrium could be established in less than 1.0 second at pressures exceeding 50 atmospheres. This cycle could be operated at these higher pressures if the compressor inlet temperature were 100° F or higher. This inlet temperature would allow use of higher pressure ratios without causing the two-phase region in the compressor. The effect of the higher compressor inlet temperature on system performance would be relatively small because of the high work ratios for reacting-gas cycles.

Another possible advantage of using a reacting gas is reduced heat-exchanger size. In reacting-gas systems, heat transfer occurs not only by molecular conduction but also by molecular diffusion in the form of chemical enthalpy. It is expected that the surface area of a recuperator for N_2O_4 would be considerably less than that for an inert gas because of its higher heat-transfer coefficient and because of the higher average driving temperature difference through the recuperator for the same minimum temperature difference.

Another area of concern is material compatibility. Reacting gases, such as N_2O_4 , are generally toxic and corrosive. Although this problem was not investigated in this study, the information given in reference 13 indicates that a large number of steels and alloys are corrosion resistant to N_2O_4 within the temperature range 80° to 1300° F and the pressure range 1 to 150 atmospheres.

As pointed out in the section LITERATURE REVIEW, the reacting gas N_2O_4 is also an attractive working fluid in a condensing cycle. It has a saturation line such that condensing temperatures between 70° and 90° F correspond to pressures between 1.0 and 1.6 atmospheres. Thus, compared with steam turbines, N_2O_4 turbines could be greatly reduced in size because of the high molecular weight and high system pressures (turbine exhaust above atmospheric compared with below atmospheric for steam). Reference 7, which supports this reduced turbine size (and cost), describes the design for a complete 1000-megawatt single-shaft turbine that would be less than one-fifth as heavy as a comparable steam turbine. Also, if a condensing cycle system were used, pressures which optimize the reaction rates for a particular size power system could be selected.

APPENDIX - ANALYTICAL PROCEDURE

A temperature-entropy diagram for a typical reacting-gas (N_2O_4) turbine cycle is shown in figure 9. The performance values presented in this report were obtained by using standard thermodynamic relations. Thermodynamic efficiency is defined here as

$$\eta = \frac{W_{net}}{Q_{in}} = \frac{W_t - W_c}{Q_{in}} \quad (A1)$$

where turbine specific work is

$$W_t = h_4 - h_5 = \eta_{ta} (h_4 - h_{5s}) \quad (A2)$$

the compressor specific work is

$$W_c = h_2 - h_1 = \frac{1}{\eta_{ca}} (h_{2s} - h_1) \quad (A3)$$

and the specific energy input is

$$Q_{in} = h_4 - h_3 \quad (A4)$$

in which η_{ta} is the turbine adiabatic efficiency, η_{ca} is the compressor adiabatic efficiency, and h_1 is the enthalpy corresponding to cycle state points shown in figure 9.

Therefore

$$\eta = \frac{\eta_{ta} (h_4 - h_{5s}) - \frac{1}{\eta_{ca}} (h_{2s} - h_1)}{h_4 - h_2} \quad (A5)$$

Enthalpy as a function of temperature and pressure is calculated by using the computer code of reference 11. State point enthalpies around the cycle are determined as a function of specific cycle pressure ratio, compressor inlet conditions, and turbine inlet temperature by using equations (A2) and (A3) and a heat balance on the recuperator. Frequently in cycle analysis the recuperator is characterized by assuming an effectiveness. However, for reacting-gas cycles, the relation of recuperator inlet and exit conditions to the effectiveness is complicated because of the dependence of specific heat on both temperature and pressure (fig. 10). This dependence does not allow the use of effectiveness to determine recuperator inlet and exit conditions. Therefore, in this analysis, the recuperator is characterized by specifying the minimum temperature difference (ΔT_{min}) between the high and low-pressure sides of the recuperator at any location.

The point where ΔT_{min} occurs is located by the following procedure: The mass flows through the high and low-pressure sides of the recuperator are assumed to be equal, and pressure losses through the recuperator are neglected. Figure 11 shows a diagram of a counterflow heat exchanger and the distribution of temperature as a function of heat flow. Let $T_{L,1}$ be the temperature at any point along the low-pressure side of the

recuperator and $T_{H,1}$ be the temperature at the same location on the high-pressure side. Then

$$T_{H,1} = T_{L,1} - \Delta T_1$$

where ΔT_1 is the temperature difference at the 1th location. A heat balance from the cold inlet end to the 1th cross section is

$$H(P_L, T_{L,1}) - H(P_L, T_6) = H(P_H, T_{H,1}) - H(P_H, T_2) \quad (A6)$$

Differentiating with respect to $T_{L,1}$ gives

$$\frac{\partial H(P_L, T_{L,1})}{\partial T_{L,1}} = \frac{\partial H(P_H, T_{H,1})}{\partial T_{L,1}}$$

Since

$$\frac{\partial H(P_L, T_6)}{\partial T_{L,1}} = \frac{\partial H(P_H, T_2)}{\partial T_{L,1}} = 0$$

By definition

$$c_p \equiv \left(\frac{\partial H}{\partial T} \right)_p$$

so that

$$\frac{\partial H(P_L, T_{L,1})}{\partial T_{L,1}} = c_p(P_L, T_{L,1})$$

Also

$$\frac{\partial H(P_H, T_{H,1})}{\partial T_{L,1}} = \frac{\partial H(P_H, T_{H,1})}{\partial T_{H,1}} \frac{\partial T_{H,1}}{\partial T_{L,1}} = c_p(P_H, T_{H,1}) \frac{\partial T_{H,1}}{\partial T_{L,1}}$$

but

$$\frac{\partial T_{H,1}}{\partial T_{L,1}} = 1 - \frac{\partial(\Delta T_1)}{\partial T_{L,1}}$$

Therefore

$$c_p(P_L, T_{L,1}) = c_p(P_H, T_{H,1}) \left(1 - \frac{\partial(\Delta T_1)}{\partial T_{L,1}} \right)$$

or

$$c_p(P_L, T_{L,1}) = c_p(P_H, T_{L,1} - \Delta T_1) \left(1 - \frac{(\Delta T_1)}{\partial T_{L,1}} \right)$$

$$\frac{\partial(\Delta T_1)}{\partial T_{L,1}} = 1 - \frac{c_p(P_L, T_{L,1})}{c_p(P_H, T_{L,1} - \Delta T_1)}$$

Setting this derivative equal to zero gives a value of $T_{L,1}$ which maximizes or minimizes ΔT_1 :

$$1 - \frac{c_p(P_L, T_{L,1})}{c_p(P_H, T_{L,1} - \Delta T_1)} = 0$$

$$c_p(P_L, T_{L,1}) = c_p(P_H, T_{L,1} - \Delta T_1) \quad (A7)$$

Equation (A7) can also be used to determine the value of $T_{L,1}$ when a value of $\Delta T_1 = T_{min}$ is given, $T_{L,1}$ can then be used in equation (A6) to determine the properties at point 6 (i.e., $H(P_L, T_6)$ and T_6). Once the properties at point 6 are known, the conditions at point 3 can be determined by performing a heat balance on the entire recuperator (the states at points 2 and 5 having previously been determined by eqs. (A2) and (A3)).

Equation (A7) is solved for $T_{L,1}$ graphically, as illustrated in figure 10, where specific heat is plotted as a function of temperature and pressure. Along a low-pressure curve (i.e., $c_p = f(P_L, T)$), there is a position such that between the low- and high-pressure curves ($c_p = f(P_H, T)$) the distance along the temperature axis is equal to the given value of ΔT_{min} . The temperature on the low-pressure curve corresponding to this position is a value of $T_{L,1}$ which satisfies equation (A7). As can be seen from figure 10, there are three such possible roots of equation (A7), depending on the temperature range of the recuperator. In such cases, all possible roots must be checked to determine which value is associated with ΔT_{min} .

Once the enthalpy h_3 at the exit of the high-pressure side of the recuperator is known, the efficiency can be determined by equation (A5).

REFERENCES

1. Nesterenko, V. B.: Thermodynamic Schemes and Cycles of APS Using the Dissociating Gases. Dissociating Gases as Heat-Transfer Media and Working Fluids in Power Installations. AEC-tr-7295, Energy Research and Development Admin., 1975, pp. 9-23.
2. Nesterenko, V. B.; Tverkovkin, B. E.; Shinkevich, O. S., and Pleshchenko, G. A.: Calculation of the Parameters of Chemically Reacting Flow through a Heated Channel. Dissociating Gases as Heat Transfer Media and Working Fluids in Power Installations. AEC-tr-7295, Energy Research and Development Admin., 1975, pp. 233-248.
3. Devoino, A. N.: Experimental Study of Convective Heat Transfer in the Dissociating Gases. Dissociating Gases as Heat-Transfer Media and Working Fluids in Power Installations. AEC-tr-7295, Energy Research and Development Admin., 1975, pp. 199-209.
4. Gokhshtein, D. P., et al.: Estimation of the Thermodynamic Effectiveness of Cycles Working on Thermally Dissociating Fluids. Dissociating Gases as Heat-Transfer Media and Working Fluids in Power Installations. AEC-tr-7295, Energy Research and Development Admin., 1975, pp. 49-56.
5. Sukhotin, A. M., et al.: Corrosion Kinetics of Stainless Steels and Aluminum in N_2O_4 . Dissociating Gases as Heat-Transfer Media and Working Fluids in Power Installations. AEC-tr-7295, Energy Research and Development Admin., 1975, pp. 109-115.
6. Sukhotin, A. M., et al.: Stability of Construction Materials in N_2O_4 at Heat-Transfer Media and Working Fluids in Power Installations. AEC-tr-7295, Energy Research and Development Admin., 1975, pp. 116-123.
7. Lomashev, B. I. and Nesterenko, V. B.: Gas Turbines with Dissociating Working Fluids. Dissociating Gases as Heat-Transfer Media and Working Fluids in Power Installations. AEC-tr-7295, Energy Research and Development Admin., 1975, pp. 74-80.
8. Jacobs, T. A. and Lloyd, J. R. The Influence of the Equilibrium Dissociation of a Diatomic Gas on Brayton-Cycle Performance. J. Appl. Mech., vol. 30, no. 2, June 1963, pp. 288-290.
9. Cheung, H.: Dissociating Gas as a Working Fluid for Space Plant. Energy Convers., vol. 8, no. 3, 1968, pp. 125-128.
10. Johnson, K. P.: Thermally Dissociative-Gas Power-Conversion Cycle. U.S. Patent 3,370,420, February 27, 1968.
11. Gordon, S. and McBride, B. J.: Computer Program for Calculation of Complex Chemical Equilibrium Compositions, Rocket Performance, Incident and Reflected Shocks, and Chapman-Jouguet Detonations. NASA SP-273, rev., 1976.

12. Bittker, D. A. and Scullin, V. J.: General Chemical Kinetics Computer Program for Static and Flow Reactions, with Application to Combustion and Shock-Tube Kinetics. NASA TN D-6586, 1972.
13. Nesterenko, V. B.: Dissociating Nitrogen Tetroxide as a Prospective Heat-Transfer Agent and Working Substance of Atomic Energy Plants with Gas-Cooled Fast Nuclear Reactors. Teploenergetika, no. 1, 1972, pp. 72-78.

TABLE I. - PARAMETRIC VARIATIONS FOR REACTING-GAS CYCLE ANALYSIS

Working fluid	nitrogen tetroxide (N ₂ O ₄)
Turbine inlet temperature, °F	1000, 1200, 1500
Compressor pressure ratio	2.0, 3.0, 5.0, 7.0, 10.0
Loss pressure ratio	0.913
Recuperator $\Delta P/P$	
High-pressure side.	0.033
Low-pressure side	0.038
Heat input heat exchanger $\Delta P/P$	0.006
Precooler $\Delta P/P$	0.012
Turbine efficiency (polytropic)	0.858
Compressor efficiency (polytropic).	0.820
Compressor inlet temperature, °F.	98.0
Recuperator minimum ΔT , °F	25
Compressor inlet pressure, atm.	1.36

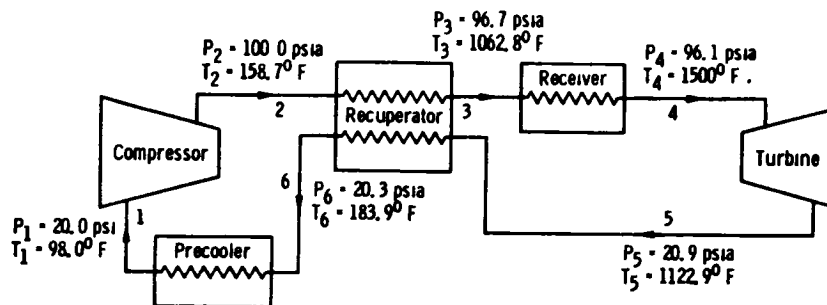

State point	Gas	Mole fraction	State point	Gas	Mole fraction
1	NO ₂	0.396	4	NO	0.628
	N ₂ O ₄	.603		NO ₂	.058
2	NO ₂	.391		O ₂	.314
	N ₂ O ₄	.608	5	NO	.590
3	NO	.493		NO ₂	.115
	NO ₂	.261		O ₂	.295
	O ₂	.246	6	NO ₂	.849
		N ₂ O ₄		.150	

Figure 1 - Closed Brayton cycle using a dissociating gas (N₂O₄) Pressure ratio, 5.0; N₂O₄ = 2NO₂ - 268 Btu/lbm = 2NO + O₂ - 529 Btu/lbm, average number of moles through component, \bar{N}_c , 1.86; \bar{N}_t , 4.31; \bar{N}_t/\bar{N}_c , 2.31.

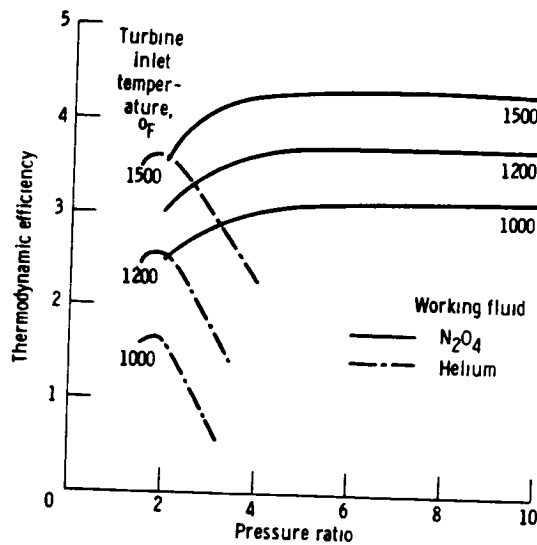

Figure 2 - Comparison of thermodynamic efficiencies for closed Brayton cycle using N₂O₄ and helium as working fluid

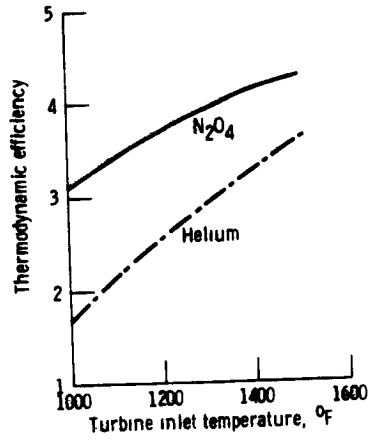

Figure 3 - Comparison of thermodynamic efficiency over range of turbine inlet temperature at optimum pressure ratio

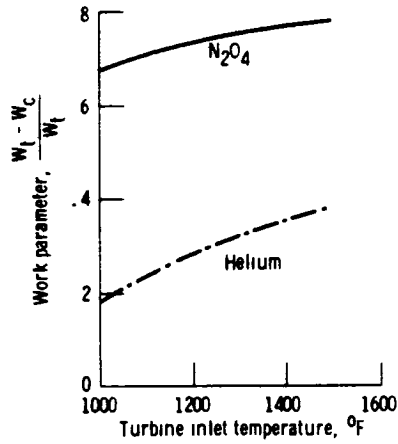
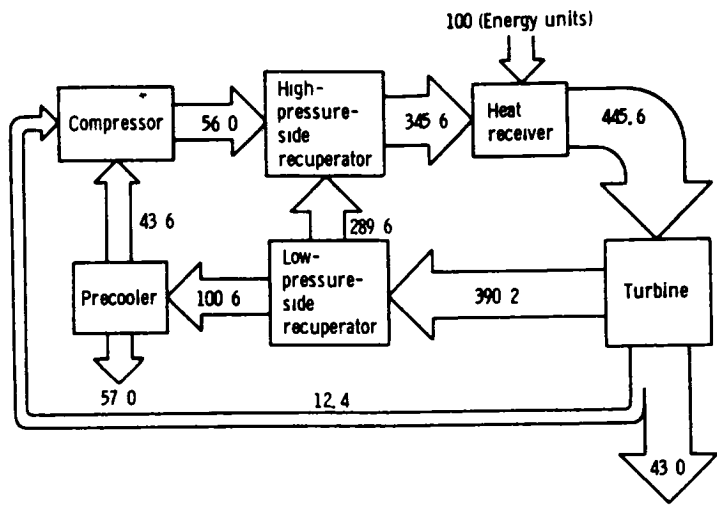
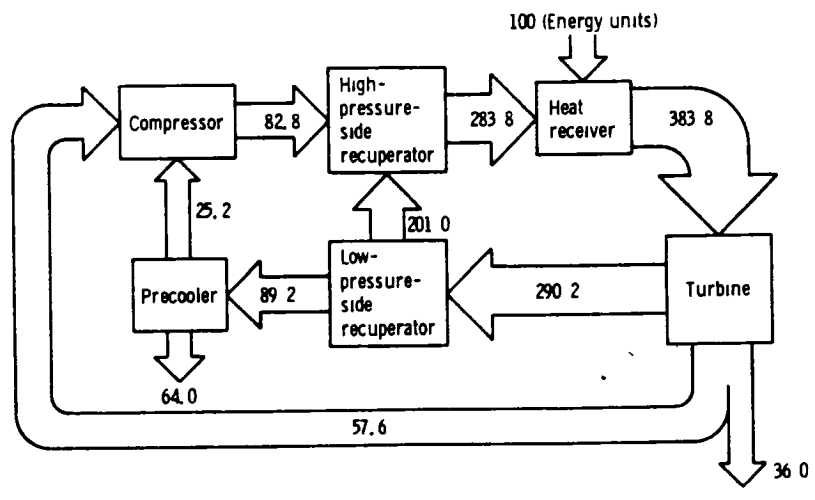

Figure 4 - Comparison of work parameter over range of turbine inlet temperatures at optimum pressure ratio



(a) N_2O_4 pressure ratio, 5.0



(b) Helium, pressure ratio, 2.0

Figure 5 - Comparison of energy flow paths for N_2O_4 and helium. Compressor temperature, $98^\circ F$, turbine inlet temperature, $1500^\circ F$, optimum pressure ratio

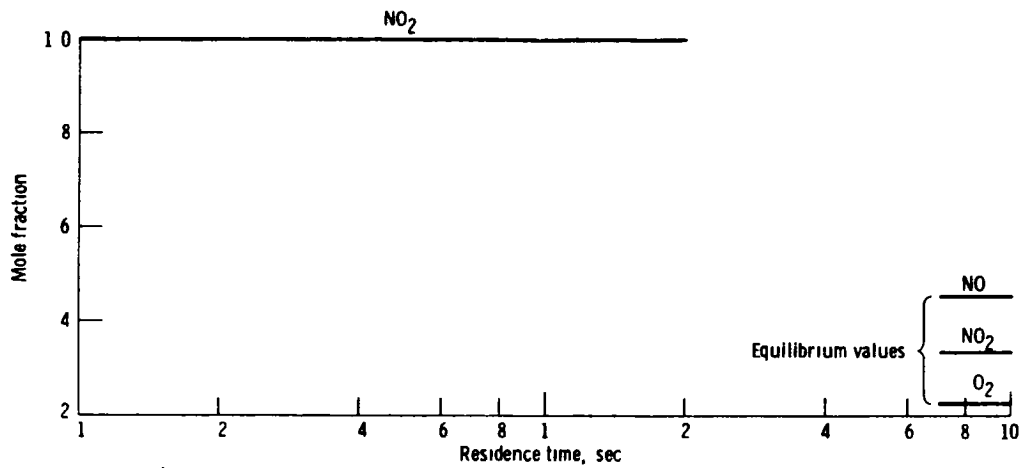

Figure 6 - Variation in relative concentration (mole fraction) with time for reaction $\text{N}_2\text{O}_4 \rightleftharpoons 2\text{NO}_2 \rightleftharpoons 2\text{NO} + \text{O}_2$ at 1000°F . Mole fraction of NO and $\text{O}_2 < 10^{-4}$ for residence times ≤ 2.0 seconds, initial concentrations N_2O_4 0.608, NO_2 0.392, pressure, 3.0 atmospheres

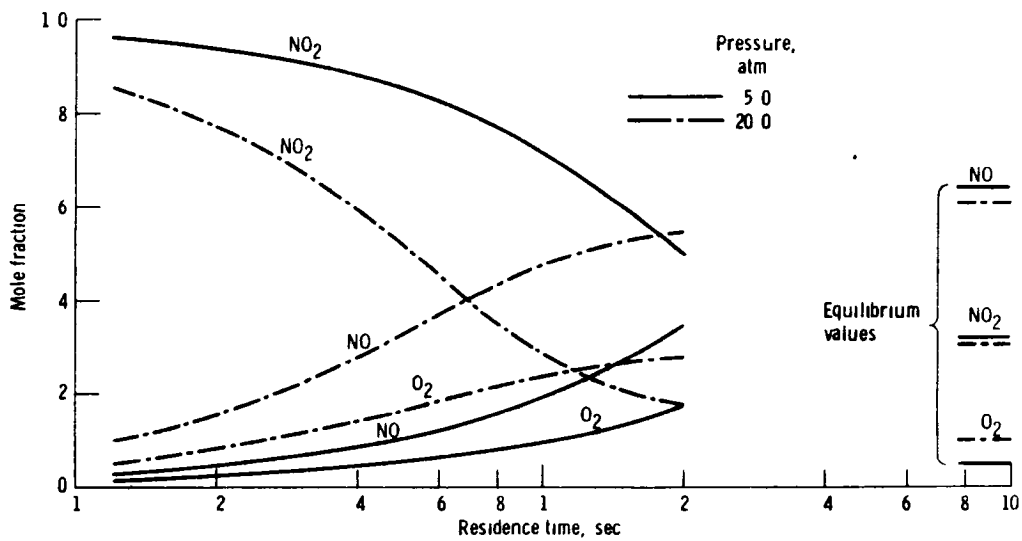

Figure 7 - Variation in relative concentration (mole fraction) with time for reaction $\text{N}_2\text{O}_4 \rightleftharpoons 2\text{NO}_2 \rightleftharpoons 2\text{NO} + \text{O}_2$ at 1500°F . Initial concentrations N_2O_4 0.608, NO_2 0.392

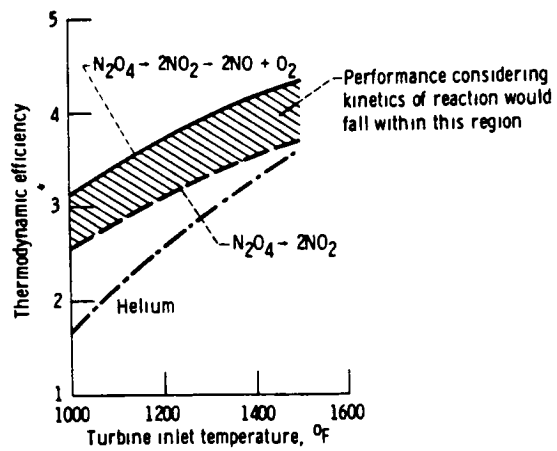

Figure 8. - Comparison of performance for three working fluids equilibrium mixture of N_2O_4 , NO_2 , NO , and O_2 ; equilibrium mixture of N_2O_4 and N_2O , and inert gas (helium)

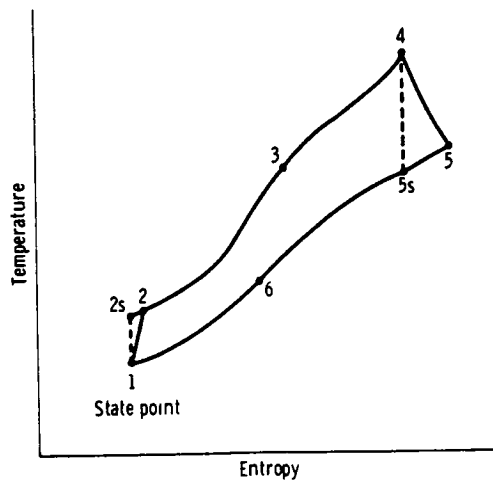

Figure 9 - Temperature-entropy diagram for reacting-gas Brayton cycle

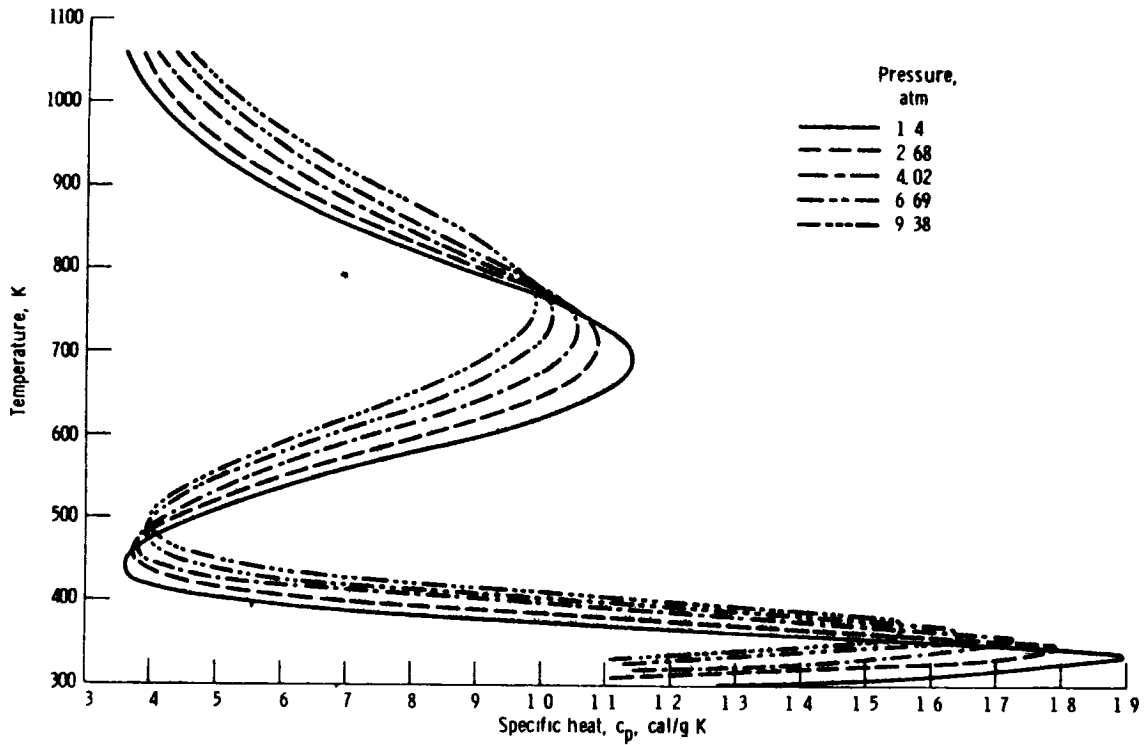

Figure 10 - Specific heat as function of temperature for N_2O_4 at five pressures

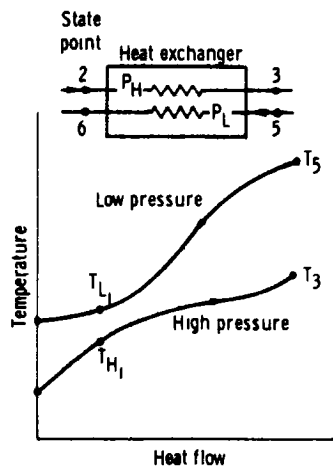

Figure 11 - Temperature distribution as function of heat flow in counter-flow heat exchanger

End of Document