

*NASA CR-161,371*

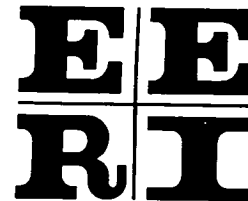

3 1176 00139 2209

**Earthquake Engineering  
Research Institute**



NASA-CR-161371

*19800008390*

**POTENTIAL UTILIZATION OF THE  
NASA/GEORGE C. MARSHALL SPACE FLIGHT CENTER  
IN EARTHQUAKE ENGINEERING RESEARCH**

A Technical Evaluation  
Conducted During a Site Visit and Workshop  
Sponsored by  
The National Science Foundation  
and  
The National Aeronautics and Space Administration

December 1979



NF01815

**POTENTIAL UTILIZATION OF THE  
NASA/GEORGE C. MARSHALL SPACE FLIGHT CENTER  
IN EARTHQUAKE ENGINEERING RESEARCH**

**A Technical Evaluation  
Conducted During a Site Visit and Workshop  
Sponsored by  
The National Science Foundation  
and  
The National Aeronautics and Space Administration**

**Prepared for  
The George C Marshall Space Flight Center  
Marshall Space Flight Center, Alabama 35812**

**by  
The Earthquake Engineering Research Institute  
2620 Telegraph Avenue  
Berkeley, California 94204**

**Edited by  
Roger E Scholl**

**December 1979**

*N80-16650 #*

**This Page Intentionally Left Blank**

## Abstract

A technical evaluation was made of earthquake engineering research capabilities of the National Aeronautics and Space Administration (NASA) facilities at George C. Marshall Space Flight Center (MSFC), Alabama, during a site visit and workshop, held at MSFC, on February 22, 23, and 24, 1979. Workshop participants included twenty-six earthquake engineering specialists from the academic community, industry, and government. The workshop was sponsored by the National Science Foundation and NASA, and it was hosted by MSFC. The chairmanship and overall direction of the workshop was assumed by the Earthquake Engineering Research Institute.

The results of the workshop indicate that the NASA/MSFC facilities and supporting capabilities offer unique opportunities for conducting earthquake engineering research. Specific features that are particularly attractive for large-scale static and dynamic testing of natural and man-made structures include the following: large physical dimensions of buildings and test bays; high loading capacity; wide range and large number of test equipment and instrumentation devices; multichannel data acquisition and processing systems; technical expertise for conducting large-scale static and dynamic testing; sophisticated techniques for systems dynamics analysis, simulation, and control; and capability for managing large-size and technologically complex programs.

On the basis of the site visit and discussions, potential uses of the facilities for near- and long-term test programs to supplement current earthquake research activities were suggested. They included static-cyclic and dynamic testing of prototype multistory buildings and other structures, structural components, and equipment; medium- to large-scale model tests to study the dynamic behavior of soil masses and earth structures under earthquake excitation; and dynamic soil-structure interaction tests utilizing the MSFC grounds as a test site.



It was concluded that the capabilities of Spacelab offer unique opportunities for conducting basic soils research in the near-zero-gravity environment and vacuum of space. Insights gained from in-space research should have broad geotechnical engineering applications, including the prediction of soil behavior during earthquakes. In particular, direct information on the constitutive relations of soils under very low effective confining stresses could be obtained for the first time from soil mechanics experiments conducted in space. Such information is vital to a quantitative analysis of liquefaction and material softening induced by seismic loading.

In summary, the consensus of the workshop participants was that the unique NASA facilities and technical capabilities could augment other existing United States facilities and thus expedite realization of the goals of the *Earthquake Hazards Reduction Act of 1977* (United States Public Law 95-124, October 7, 1977). Since cost data were not available to the workshop participants, cost analyses based on specific test requirements relative to any such research efforts must be made prior to implementation of those efforts.

## Foreword

The past decade has provided significant advances in, and demonstrated the advantages of, earthquake engineering technology. The potential hazard of earthquakes in the United States is much more clearly understood today. Consciousness of the earthquake hazard has been raised significantly among design professionals, and mitigation of this hazard to man is being vigorously sought through improved design and construction.

Experimental testing is an important means for determining where design improvements for a structure can and should be made. The potential for full-scale testing of structures at the NASA/Marshall Space Flight Center, combined with the potential for basic and applied research on the intrinsic mechanical properties of earth masses and their dynamic interaction with engineering structures, as discussed in this report, has been heretofore unattainable. Yet, this research potential could provide the most conclusive means of ensuring reliable and seismic-resistant design and construction.

With this background in mind, the EERI Board of Directors has reviewed this report, and it is issued with their approval.

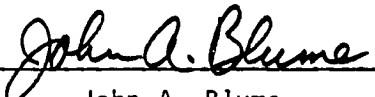
  
John A. Blume  
President

  
Robert V. Whitman  
Vice President

  
Christopher Rojahn  
Secretary

-----

## Preface

This report documents the results of a three-month study conducted by the Earthquake Engineering Research Institute (EERI) under Contract NAS8-33220 with the NASA/George C. Marshall Space Flight Center (MSFC), Alabama. The study was sponsored by the Office of Space and Terrestrial Applications (OSTA) of NASA Headquarters, Washington, D.C., and was conducted under the technical cognizance of Dr. Nicholas C. Costes, Space Sciences Laboratory, MSFC.

The report is based on the findings of a three-day site visit and workshop, sponsored by the National Science Foundation (NSF) and hosted by MSFC, that was held at MSFC on February 21 to 23, 1979, for the purpose of assessing potential utilization of unique NASA/MSFC facilities and technical capabilities in earthquake engineering research.

Special credit is due the many workshop participants listed in Appendix A of this report. The time and effort they contributed under the direction of Dr. John A. Blume, President of the EERI, has made this evaluation possible.

In addition, credit is given to Dr. John B. Scalzi and Dr. William W. Hakala of the NSF for their efforts in organizing and sponsoring the workshop, to Dr. George F. McDonough, Mr. Robert S. Garrett, and Dr. Nicholas C. Costes of NASA/MSFC for their efforts as coordinators of the workshop, and to Mr. Thomas L. Fischetti of OSTA for his continued interest and support. Thanks are extended to Mrs. Naomi Honea and Mrs. Evelyn Terry of NASA/MSFC for their efforts in the onerous task of typing and retyping the workshop subcommittee draft reports at night between the daytime scheduled meetings.

Numerous technical personnel of NASA/MSFC should be given credit for their invaluable assistance and cooperation during the preparation of this report. Dr. T. Allan Moore and Ms. Barbara A. Lee of URS/John A. Blume & Associates, Engineers, also deserve credit for their assistance in drafting and editing this report.

Roger E. Scholl, Editor  
URS/John A. Blume & Associates, Engineers

**This Page Intentionally Left Blank**

# Contents

	<u>Page</u>
ABSTRACT .....	iii
FOREWORD .....	v
PREFACE .....	vii
EXECUTIVE SUMMARY .....	xi
1. INTRODUCTION .....	1
2. PERSPECTIVE FOR EVALUATING THE NASA/MSFC FACILITIES .....	5
Research Needs in Earthquake Engineering .....	5
Large-Scale Earthquake Engineering Test Facilities .....	8
Static-Cyclic (Pseudodynamic) Testing .....	8
Shaking Table Testing .....	10
Vibration Generator Testing .....	11
Underground Explosion Testing .....	12
Soil Dynamics Testing .....	13
U.S.-Japan Large-Scale Research Program .....	17
3. NASA/MSFC TEST FACILITIES .....	21
MSFC Ground-Based Test Facilities .....	21
MSFC Test Equipment .....	22
MSFC Test Support Capabilities .....	26
MSFC Structural Test and Data Acquisition System (STDAS) .....	26
Spacelab .....	27
4. REPORT OF THE STRUCTURAL COMMITTEE .....	33
Static-Cyclic Load Testing of Full-Scale Buildings .....	34
Response of Fluid-Filled Tanks .....	37
Shaking Table Tests .....	38
Elastic Response of Large Piping and Other Line Systems .....	39
System Identification Studies (Damage Assessment) .....	39
Explosion-Generated Earthquake-Like Ground Motion Studies .....	40
5. REPORT OF THE GEOTECHNICAL COMMITTEE .....	43
Dynamic Behavior of Soils and Earth Structures .....	44
Laboratory Model Soil Testing .....	44
Field Testing of Dynamic Soil Behavior .....	47

## CONTENTS (Continued)

	<u>Page</u>
Dynamic Soil-Structure Interaction .....	48
Field Testing .....	48
Laboratory Testing .....	53
Field Services for Dynamic Studies of Soils and Soil- Structure Interaction .....	53
In-Space Research on Soil Behavior .....	54
6. MANAGEMENT, OPERATION, AND FUNDING OF NASA/MSFC FOR EARTHQUAKE ENGINEERING RESEARCH .....	57
7. CONCLUSIONS AND RECOMMENDATIONS .....	59
Conclusions .....	59
Recommendations .....	60
REFERENCES .....	63

### APPENDICES

- A Roster of Workshop Participants
- B Workshop Agenda
- C Research Needs in Earthquake Engineering
- D Large-Scale Earthquake Engineering Test Facilities in the United States  
and Abroad
- E Test Equipment and Facilities at NASA/MSFC
- F Structural Test and Data Acquisition System at NASA/MSFC
- G Spacelab Configuration: Functional and Operational Capabilities

### FIGURES

1 Aerial View of MSFC .....	25
2 Mock-up of Spacelab Module .....	31
3 Comparison of Static-Cyclic Test Facilities: Tsukuba New Town and MSFC .....	35
4 Rocket Fuel Tank Section Being Readied for Structural Testing .....	45
5 Geology Underlying MSFC .....	49

## Executive Summary

The *Earthquake Hazards Reduction Act of 1977* (United States Public Law 95-124, October 7, 1977) directs the President "to establish and maintain an effective earthquake hazards reduction program." A well-recognized and important objective of earthquake hazards reduction is the testing of man-made works to make them resistant to the hazards imposed by earthquakes.

On February 22, 23, and 24, 1979, a site visit and workshop, sponsored by the National Science Foundation (NSF) and hosted by the National Aeronautics and Space Administration (NASA), was held at the NASA/George C. Marshall Space Flight Center (NASA/MSFC) in Huntsville, Alabama, to assess the potential use of NASA/MSFC as a large-scale test facility for earthquake engineering research. Participating in the assessment were twenty-six specialists in earthquake engineering research from industry, the academic community, and government. The workshop was organized and directed by the Earthquake Engineering Research Institute.

The workshop involved a technical evaluation of the NASA/MSFC facilities in the following areas, as related to earthquake engineering research:

- Structural Engineering
- Geotechnical Engineering
  - Dynamic soil behavior and earth structures
  - Dynamic soil-structure interaction
  - In-space research on soil behavior

The workshop participants were divided into two committees -- one for structural engineering and one for geotechnical engineering -- in accordance with their interest and expertise. The Geotechnical Committee was further divided into subcommittees consistent with the three subject areas listed above. Committee meetings were interspersed with plenary sessions to facilitate a thorough evaluation of the facilities and to ensure continuity. Several NASA/MSFC experts in the operation and use of the facilities participated, particularly in the committee meetings, to provide detailed information re-



garding capabilities and limitations of the MSFC test facilities. At the conclusion of the workshop, each committee provided a written report of its findings.

The committees found that the NASA/MSFC facilities provide the opportunity to conduct larger scale earthquake engineering testing than has ever been feasible in the United States. The most important attributes of the NASA/MSFC facilities as they relate to large-scale earthquake engineering testing are size, capacity, and versatility: the buildings and test bays can accommodate full-scale test articles, including multistory buildings or other structures and structural components; several high-capacity hydraulic and electrodynamic loading devices provide a wide spectrum of capabilities for large-scale static and dynamic testing; a large number of smaller capacity dynamic shakers and actuators, as well as a variety of instrumentation devices of different ranges and sensitivities, can be utilized for multifacet structural and geotechnical earthquake engineering research. In addition, the Structural Test and Data Acquisition System, one of the data acquisition and processing systems at MSFC, has a maximum capacity of 6,000 channels and a capability of real-time monitoring of up to 48 channels during a test. Accordingly, the STDAS, in conjunction with the MSFC Automatic Load Control System, is fully capable of automated test control and of recording the many data channels necessary to perform large-scale testing in a productive and efficient manner. Moreover, the technical expertise of the NASA/MSFC personnel for dynamic analysis, simulation, control, and large-scale testing is substantiated by the more than 25 years of in-house experience and the multitude of space flight successes to which NASA/MSFC has contributed. These unique capabilities, in conjunction with the extensive experience of NASA/MSFC with multidisciplinary large-scale programs and coordination of complex scientific and engineering experiments and other research activities with individual Principal Investigators and/or multinational research teams, could be effectively utilized for conducting large-scale earthquake engineering testing.

The MSFC facilities are well suited for large-scale testing, and they should be considered mainly for that purpose. Adequate facilities for smaller scale testing currently exist at various universities and other laboratories throughout the United States.

The need for conducting large-scale testing is clearly demonstrated by the Japanese experience. Earthquakes of moderate size occur frequently in Japan, and hazardous construction practices are revealed more quickly there than in the United States. Japanese engineers long ago recognized the need for and benefits of large-scale testing. Their dedication to earthquake research is underscored by a recent indication that Japan's new 15-m x 15-m shaking table will not be available for non-Japanese testing for at least 10 years. If the facilities at NASA/MSFC should become available, a significant large-scale earthquake engineering test capability could be realized in the United States, which could complement and enhance earthquake engineering research performed in this country and abroad.

During the course of the workshop, several important testing programs were identified that could be performed using the existing MSFC facilities with little or no modification. The specific testing programs identified include:

- Static-cyclic testing of a small full-scale masonry and/or steel building
- Dynamic tests of soil behavior using large test bins
- Field soil-structure interaction tests of footings
- Soil-structure interaction tests employing existing buildings at MSFC
- Centrifuge testing of model soil structures

Other earthquake engineering test programs that would require varying degrees of modification were also identified. It is expected that more detailed task committee evaluations of the NASA/MSFC facilities would reveal additional earthquake engineering testing applications.

In addition to evaluating the ground-based test facilities at MSFC and their applicability to large-scale earthquake engineering research, the workshop also considered geotechnical research areas that would benefit from the use of the orbiting laboratory, Spacelab. Spacelab offers geotechnical engineers the unique opportunity to perform tests under high-vacuum and zero-gravity conditions during sustained periods (several days to several weeks).

Several geotechnical research areas that might benefit from experiments conducted in the ultrahigh vacuum of space were identified. However, the immediate use of Spacelab relates to the sustained zero-gravity environment. Zero gravity assumes special importance in soils because of the strong gravity dependence of all aspects of their mechanical behavior, which is governed predominantly by interparticle friction. This is in contrast to other engineering materials, the properties of which are controlled by cohesive forces of atomic and molecular interaction and are, therefore, essentially gravity independent. Typical phenomena and properties considered for experimentation under zero-gravity conditions include:

- Stress-strain and strength under low confinement
- True cohesion in fine-grained soils
- Tensile strength of fine-grained soils
- Colloidal phenomena in fine-grained soils
- Capillary phenomena

Insight derived from such experiments should have broad geotechnical engineering applications, including the prediction of soil behavior during earthquakes. For example, understanding the behavior of granular materials under low effective confining stresses is crucial to a quantitative explanation of liquefaction and material softening induced by earthquake loading.

An evaluation of the cost that would be involved in conducting large-scale earthquake engineering testing at NASA/MSFC was beyond the scope of the workshop. The workshop participants discussed various management, operation, and funding possibilities for such a potential large-scale test program, but no recommendations were made. Because of various considerations, it appears that management and operation of the facility for earthquake research could best be done by NASA. A practicable funding plan could involve interagency cooperation, with NASA providing the test facilities and manpower for facility management and operation and with the using agency meeting the costs of scientific project planning and implementation, test specimens, and special test fixtures. Under this plan, NASA/MSFC would manage and operate the test facilities, but earthquake engineering researchers and their staffs would be responsible for planning, coordinating, and overseeing specific test programs.

The results of the workshop indicate that the availability of the NASA/MSFC facilities for large-scale testing has a high potential for introducing a new dimension in earthquake engineering research that heretofore has been unfeasible. However, because the objectives of the workshop were limited to only a technical evaluation of the NASA/MSFC facilities, final recommendations for the implementation of an earthquake engineering research program utilizing these facilities should await the results of comprehensive cost analyses. These analyses should be based on specific test requirements developed for such a program. Thus, a follow-up activity to the workshop should be the development of various classes of short- and long-range test programs, with sufficient detail as to test requirements, so that realistic cost analyses can be performed.

# 1. Introduction

It is the stated purpose of the *Earthquake Hazards Reduction Act of 1977* (United States Public Law 95-124, October 7, 1977) "to reduce the risks to life and property from future earthquakes in the United States through the establishment and maintenance of an effective earthquake hazards reduction program." The Act specifies several federal agencies that shall participate in achieving the objectives of the program.

Two of the federal agencies named in the Act, the National Science Foundation (NSF) and the U.S. Geological Survey (USGS), have been assigned to leading roles in the program. The NSF has the primary responsibility for basic and applied earthquake engineering research, and the USGS has the primary responsibility for developing and implementing earthquake predictive methods. Both agencies are responsible for fundamental earthquake research.

The other federal agencies named in the Act have been assigned to supportive roles in the earthquake hazards reduction program. These agencies are assisting the NSF and the USGS to achieve program objectives. Among the supportive agencies is the National Aeronautics and Space Administration (NASA).

One of the program objectives toward which NASA is already working is earthquake prediction. It is well recognized that a basic understanding of plate tectonics will be required before the practical objective of earthquake prediction is likely to be achieved. NASA has therefore developed a broad-based geodynamics program, the goal of which is to assist in establishing an understanding of crustal movement in seismically active areas.<sup>1</sup> However, in recognition of its responsible role in the earthquake hazards reduction program, NASA has been investigating the possibility of contributing to other program objectives as well.

A very important objective of the earthquake hazards reduction program is the development of seismic-resistant structures. To develop such structures, it is necessary to have facilities available that can accommodate large-scale testing of buildings and soil foundations. Unfortunately, very few facilities of this kind exist in the United States.

Realizing that a domestic large-scale earthquake engineering test facility would contribute greatly to the earthquake hazards reduction program, NASA has suggested that one of its facilities, the George C. Marshall Space Flight Center (MSFC) in Huntsville, Alabama, might be used for conducting research to improve the seismic-resistant design and construction of structures and soil foundations.

Virtually all of the full-scale space vehicle structural testing for NASA has been conducted at MSFC. Specifically, MSFC has had principal responsibility for developing the large-scale vehicles for the Saturn/Apollo and the Skylab programs and, in recent years, for developing the Space Shuttle main engine, the external tank, and the solid rocket boosters of the Space Transportation System (STS). Spacelab, which is currently being developed for performing in-space scientific research, will be launched using the STS and will be carried to and from orbit by the Space Shuttle. Proof testing to ensure that these structures could endure such severe loadings as engine-ignition, wind, stage-separation, and splash-down has been an important element in the success of NASA programs. Significantly, the loadings produce a vibratory response in structures similar to that produced by earthquakes.

Currently the structural test work on the STS is nearing completion -- the vehicle is scheduled to fly in 1980 or 1981. Accordingly, there is a possibility that several NASA/MSFC test facilities could become available for conducting earthquake engineering tests as early as 1981.

In view of these considerations, a three-day site visit and workshop, sponsored by the NSF, was held at NASA/MSFC on February 22, 23, and 24, 1979, to evaluate the potential use of MSFC as a national test facility for earthquake research. The site visit and workshop had two specific objectives:

- To acquaint the earthquake engineering community and other government agencies with the test facilities that exist at MSFC and to provide them with information on the functional and operational characteristics of the Space Shuttle-Spacelab and its capabilities for in-space research on soil behavior.
- To assess the extent to which these facilities can be utilized, either in their present configuration or with additions or modifications, to enhance current earthquake engineering research efforts.

Approximately twenty-five persons knowledgeable in earthquake engineering research from both the academic and consulting engineering communities were invited to the workshop. In addition, representatives from some fifteen governmental organizations were asked to attend and participate. Of those invited, twenty-six were able to attend. A roster of the workshop participants, as well as a list of the NASA/MSFC personnel who assisted in demonstrating the test facilities and in providing information on functional capabilities, is given in Appendix A.

The workshop involved a technical evaluation of the MSFC facilities in the following areas, as related to earthquake engineering research:

- Structural Engineering
- Geotechnical Engineering
  - Dynamic soil behavior and earth structures
  - Dynamic soil-structure interaction
  - In-space research on soil behavior

The workshop participants were divided into two committees -- one for structural engineering and one for geotechnical engineering -- in accordance with their interest and expertise. The Geotechnical Committee was further divided into subcommittees consistent with the three subject areas listed above. The workshop was begun with general introductory and background presentations, which were followed by a tour of the MSFC facilities. Thereafter, committee meetings were interspersed with plenary sessions to facilitate a thorough evaluation of the facilities and to ensure continuity. The complete agenda for the workshop is given in Appendix B.

At the conclusion of the workshop, each committee produced a written report of its findings.

The reports produced by the committees establish the potential usefulness of the NASA/MSFC facilities for earthquake engineering research. The committee reports were edited and are included herein as Chapters 4 and 5. The other chapters provide the background information that was discussed during workshop plenary sessions and that aided the committees in assessing the potential value of MSFC. These chapters were prepared by a URS/John A. Blume &

Associates, Engineers, editorial staff under contract to and subject to review by the Earthquake Engineering Research Institute.

The main purpose of this report is to document the workshop proceedings. In addition, it is intended to serve as a forum for a broader evaluation of MSFC as a large-scale earthquake engineering test facility.



## 2. Perspective for Evaluating the NASA/MSFC Facilities

The potential value of the NASA/MSFC test facilities for earthquake engineering research cannot be accurately assessed without knowledge of research needs, other existing large-scale test facilities, and research programs. Such knowledge provides a perspective for evaluating the usefulness of the MSFC facilities.

It is necessary to identify earthquake engineering research needs because the usefulness of the MSFC facilities depends on their ability to fulfill these needs. In addition, it is helpful to examine the capabilities of existing large-scale testing facilities to determine whether the capabilities of the MSFC facilities are augmentative. It is also helpful to examine the U.S.-Japan cooperative testing program to ascertain whether MSFC facilities will be an enhancement to this very important program.

### RESEARCH NEEDS IN EARTHQUAKE ENGINEERING

Severe earthquakes are a worldwide problem. Although severe earthquakes are not as commonplace in the United States as they are in some other countries, several million U.S. citizens have lived through the sobering experience of a destructive earthquake. The United States has been fortunate, however, in that the destructiveness of past earthquakes has been mitigated by the time of day they have occurred, their magnitude, and their distance from population centers. Both the large-magnitude (M 8.3 to 8.6) Alaska earthquake and the great 1811-1812 Missouri earthquake took place in sparsely populated areas of the nation. Although several moderate-magnitude earthquakes in Southern California caused significant damage, compared with recognized possibilities, the damage was almost insignificant.

The dense population centers that are developing will almost certainly multiply the detrimental effects of earthquakes in the United States. The San Francisco earthquake of 1906 was a catastrophe, but today, because of the increased population in the San Francisco Bay region, the destructiveness of a similar earthquake would be several times what it was then.

In recognition of the national interest in mitigating the destructiveness of future earthquakes, Congress passed the *Earthquake Hazards Reduction Act of 1977*. The Act directs the President "to establish and maintain an effective earthquake hazards reduction program." Furthermore, in the Research Element of the Act, the President is directed to foster the "development of methods for planning, design, construction, rehabilitation, and utilization of man-made works so as to effectively resist the hazards imposed by earthquakes."

The scope of the Act is broad. To conduct an efficient and well-organized research program, it is necessary to identify specific earthquake engineering research needs and priorities. Identification of research needs is a major effort because of the many types of structures and construction materials in use.

The NSF has convened several workshops in recent years to assess the state of the practice in earthquake engineering and to identify research needs. These workshops have produced substantive lists of research subjects, have aided in organizing research needs, and have substantially increased communication between researchers.

A survey of the earthquake engineering research needs identified in the published findings of seven NSF-sponsored workshops is given in Appendix C. According to these published findings, it is important to develop the following laboratory and field testing facilities for the purpose of (1) applying simulated earthquake loading to realistic models of soil and structural systems vulnerable to earthquake-induced damage and (2) monitoring the response of these models.

- Static-cyclic testing towers capable of applying a programmed horizontal load history in two directions with maximum forces sufficiently large to test full-scale buildings up to at least ten stories in height to destruction.<sup>2,3,4,5</sup>
- Medium- or large-size shaking tables with three or more directions of motion and maximum strokes of  $\pm 600$  mm that can be used to analyze the destructive effects of contained liquids on dams, reservoirs, tanks, etc.<sup>5</sup>

- Large-size shaking tables with two horizontal components of motion suitable for performing destructive tests of structures and components.<sup>2,3</sup>
- Large centrifuges with lightweight shaking tables capable of testing 1/100-scale models of earth structures such as dams, embankments, and building sites in a simulated earthquake environment.<sup>6</sup>
- Sites where high-explosives or nuclear devices could be detonated underground to produce a wave propagation environment with earthquake-like ground motion; such sites could be used for full-scale testing of structures, soil-structure interaction, the dynamic characteristics of soils, and the effectiveness of recently developed geophysical instruments to measure these characteristics.<sup>6,7</sup>
- Improved instruments for determining the dynamic properties of soils, both in-situ and in laboratories.<sup>5,6</sup>
- Improved instrumentation of ground motion and response of existing structures, particularly those that are critical to life support or that contain hazardous materials, during future earthquakes.<sup>5,6,7</sup>
- New testing environments, such as those provided by centrifuges, shaking tables, and Spacelab,<sup>6</sup> for the study of basic soil properties.

It is important to develop methods of simulating the phasing of input motions in connection with very long structures such as bridges and pipelines with input from shaking tables or vibration exciters.<sup>3</sup> In addition, methods of assessing the hazard vulnerability of existing structures, including lime-mortar brick buildings,<sup>2,4,5,7</sup> are needed.

Important to the subject of this report is that, on numerous occasions, the need for conducting full-scale tests has been expressed.<sup>2,3,6,7</sup> Current seismic-resistant structural design practice relies heavily on concepts of structural performance that have evolved from post-earthquake damage inspections and small-scale shaking table tests. As beneficial as these concepts are, there are many factors that cannot be evaluated by damage inspection or small-scale tests. Therefore, tests of full-scale buildings, or at least subsystems, are needed to evaluate the interaction of various building system components. Unfortunately, little capability currently exists in the United States for performing large-scale testing.

## LARGE-SCALE EARTHQUAKE ENGINEERING TEST FACILITIES

In determining the requirements for new earthquake engineering research facilities, it is helpful to review the capabilities of existing test facilities to avoid duplication. The current capabilities of several facilities used in connection with five different methods for performing large-scale testing in structural and geotechnical research in the United States and abroad are summarized below. These testing methods are:

- Static-cyclic (pseudodynamic) testing
- Shaking table testing
- Vibration generator testing
- Underground explosion testing
- Soil dynamics testing

A more complete description of the capabilities of the various facilities used in performing these types of earthquake engineering tests is given in Appendix D.

### Static-Cyclic (Pseudodynamic) Testing

In static-cyclic testing, a structural element, or a structure itself, is subjected to prescribed oscillatory displacements at a relatively slow rate of loading. The test can therefore be stopped at any time to observe the damage sequence or to reestablish data observations.

Cyclic loading equipment has been used at numerous research institutions for destructive testing of masonry walls and large joint specimens of steel frames, reinforced concrete frames, and shear walls.

The testing facility at the University of California, Berkeley, has been used for studying the in-plane seismic behavior of wall and frame subassemblages. It has a capacity to test structures 12 m in height with an applied lateral force of 500 to 1,000 tons. A series of tests has been conducted on 1/3-scale models of wall subassemblages of a 10-story, reinforced concrete frame-wall structural system and of reinforced concrete frames infilled with reinforced masonry and braced-steel-frame planar subassemblages.<sup>8</sup>

The Portland Cement Association structures laboratory in Skokie, Illinois,<sup>9</sup> has a structural reactor system capable of accommodating specimens up to 5.5 m in height. By assembling groups of hydraulic rams, lateral forces of the order of 1,000 tons may be applied. Individual rams range in capacity and stroke up to 100 tons at 0.9-m stroke. An experimental program has been implemented to investigate the behavior of 1/3-scale models of a series of reinforced concrete wall subassemblages.

The only testing of large structures has been performed at the Building Research Institute in Tokyo. Researchers there have been performing destructive static-cyclic tests of full-size apartment buildings up to five stories in height since 1967.<sup>10</sup> The load is applied incrementally, and in most of the tests the dynamic characteristics of the structures are evaluated with forced-vibration tests after each step to study the influence of damage on these characteristics.

A new facility, recently constructed in Tsukuba New Town, Japan, consists of two large testing floors with a large reaction wall between them. The reaction wall can be used for applying static or static-cyclic lateral forces to structures anchored to either of the two test floors.<sup>11</sup> The reaction wall has a height of 25 m and a width of 20 m and is 6.6 m thick. The cyclic loading actuators have a capacity of 100 tons,  $\pm 500$ -mm stroke, and a maximum ram speed of 0.2 cm/sec. The loading, deformation, and strain measurements may be input directly to a computer; subsequent loading increments can be programmed to correspond to the level of structural response measured from the previous increment.

Also, a facility that will permit three-dimensional controlled loading of large-scale models of subassemblages or 2-story full-scale three-dimensional structural systems is being constructed at the Civil Engineering Research Laboratory, Balcones Research Center, University of Texas, Austin. This structural floor-buttressed wall system will be used to conduct a comprehensive investigation of the behavior of reinforced concrete frame elements under biaxial loads.<sup>8</sup>

## Shaking Table Testing

There are more than 20 medium-size (10-m<sup>2</sup> to 40-m<sup>2</sup>) shaking tables in the world today. Only three of the shaking tables in existence are capable of producing more than one direction of motion. The most capable of these is limited to a maximum stroke of 200 mm, which may not be sufficient to test the structural elements of many full-size structures to failure.

The two largest shaking tables in the United States are both medium-size. One is operated by the University of California, Berkeley, and the other by the U.S. Army's Civil Engineering Research Laboratory (CERL) at Champaign, Illinois.<sup>8</sup> The Berkeley table has dimensions of 6.1 m x 6.1 m and is capable of vibrating a payload of 54.5 tons with a frequency range of 0 to 25 Hz, a maximum horizontal acceleration of 0.33g, and a vertical acceleration of 0.5g; it can produce motion in the two directions simultaneously. The stroke limit is  $\pm 127$  mm horizontal and  $\pm 50$  mm vertical. This facility has been used to test a series of large-scale (7/10-scale) reinforced concrete 2-story frames. The CERL shaking table has an area of 3.7 m x 3.7 m and a payload capacity of 5.4 tons. It is also capable of two directions of motion. The frequency range of the table is 0 to 200 Hz, the maximum stroke is  $\pm 100$  mm in both directions, and the maximum acceleration is 20g horizontal and 40g vertical. The application of the CERL table has been restricted to testing of systems designed for national defense use.

The only existing large (15-m x 15-m) shaking table, located in Japan, has a payload capacity of 500 tons in the horizontal plane and 200 tons vertically.<sup>12</sup> The table has a maximum stroke of only 30 mm, however, which has restricted its application to the study of the linear dynamic response of systems.

Another large (15-m x 15-m) shaking table is being constructed in Japan by the Center for Nuclear Safety Engineering Research.<sup>12</sup> The table is designed to carry a payload of 1,000 tons, with a frequency range of 0 to 30 Hz, a maximum horizontal acceleration of 1.8g, and a vertical acceleration of 0.9g. It will be able to produce motion in the two directions simultaneously. The stroke limit will be  $\pm 200$  mm horizontal and  $\pm 100$  mm vertical. It is proposed

to use this shaking table to measure the dynamic response of prototype nuclear power plant components and models, including pressure vessels.<sup>12</sup>

The application of shaking table testing to large-scale soil and soil-structure systems would require a large (15-m x 15-m) table with a payload capacity of about 2,000 tons, which is beyond the scope of existing and planned shaking tables. The alternative of small-scale simulation of body forces in shaking table tests is difficult and requires the use of a centrifuge system.

### Vibration Generator Testing

Sinusoidal-vibration rotating-mass and reciprocating-mass generators have been used to measure the elastic dynamic characteristics of numerous large structures.<sup>13,14</sup> The Central Electric Research Institute of Japan has constructed an unbalanced-mass vibration generator that is used for field measurement of the vibration characteristics of existing nuclear power plants.<sup>12</sup> The system is capable of inducing an inertial force of 500 tons at a frequency of 10 Hz.

In recent tests, full-scale multistory buildings have been forced into severe inelastic response by means of unidirectional horizontal moving-mass vibration generators. A 4-story reinforced concrete test frame at the U.S. Department of Energy's Nevada Test Site<sup>15</sup> and an 11-story reinforced concrete frame building of the Pruitt-Igoe housing complex of St. Louis<sup>16</sup> were instrumented to measure changes in mode shapes, frequencies, and damping values as the force level of excitation increased.

The hydraulic reciprocating-mass vibration generator used at the Nevada Test Site weighs 5.9 tons and operates over a frequency range of 0 to 40 Hz. The maximum piston force capacity is 5.5 tons. The large-amplitude shaker used at the Pruitt-Igoe housing complex has a maximum force capacity of 13.6 tons over a frequency range of 0.5 to 10 Hz and a maximum piston displacement of  $\pm 280$  mm. The shaker was driven by two electric motors weighing 4.5 tons each.

## Underground Explosion Testing

Conventional high explosives or nuclear devices can be detonated underground to produce a wave propagation environment with earthquake-like ground motion. Control of this motion is possible through enhancement techniques such as sequential firing, geographical distribution of blasting arrays, and construction of such barriers as relief trenches to obtain advantageous reflections of propagating waves.<sup>17,18</sup>

The Soviet Union has been evaluating the response of dams and full-scale buildings with sequentially fired detonations for at least the past decade.<sup>19</sup> The U.S. Geological Survey is currently coordinating United States and Soviet studies of the effect of sequentially fired explosions on a prototype multi-story building.<sup>6</sup>

At the U.S. Department of Energy's Nevada Test Site during the period 1965 to 1975, two 4-story reinforced concrete structures and many low-rise structures were subjected to ground motions resulting from nuclear explosions. No attempt was made to produce specific characteristics of earthquake ground motion. The dynamic responses of the structures were measured to evaluate current elastic and inelastic dynamic modeling techniques and to study the effects of nonstructural partitions and soil-structure interaction.

Several arrays of sequential, small-scale dynamite blasts were detonated at the University of California, Los Angeles, field station during 1971.<sup>20</sup> The parameters affecting the simulated earthquake ground response were investigated and the response of a 3-story structure located 30 m from the blast center was studied.

During 1972-1973, Applied Nucleonics Company, Inc., of Los Angeles detonated buried charges of high explosives to simulate only a portion of a strong-motion earthquake with a specified maximum amplitude. This was done for a seismic qualification test of a type of circuit breaker used in nuclear power plants.<sup>21</sup>

The use of underground explosions to simulate earthquakes is particularly suitable for studies of soil and soil-structure systems because these sys-



tems are composed of or surrounded by the medium through which the seismic waves propagate and therefore cannot be evaluated independently of the free-field medium.

During 1977, the University of New Mexico's McCormick Ranch Test Site was the location of an experimental program, sponsored by the Electric Power Research Institute, to evaluate the effectiveness of sequential explosions in producing earthquake-like ground motion effects on small-scale embedded cylindrical structures.<sup>18</sup>

The Corral Hollow Experimental Site of the Stanford Research Institute at Palo Alto is currently being used to develop a technique to simulate earthquakes for large-scale testing of structures and systems.<sup>22</sup> This NSF-sponsored program involves the simultaneous detonation of a line of constant-elevation downhole explosives to generate a plane wave. Subsequent sequential detonations of explosives down the same holes are controlled and timed to produce the required earthquake characteristics in the resultant superposition of plane waves.

### Soil Dynamics Testing

Information about the following major soil properties is needed in earthquake engineering:

- Dynamic moduli - Young's modulus, shear modulus, bulk modulus, and constrained modulus
- Poisson's ratio
- Damping and attenuation
- Liquefaction parameters - cyclic-shearing stress ratio, cyclic deformation, and pore-pressure response
- Shearing strength in terms of strain-rate effects

Some of these soil properties are best measured or studied in the field, others in the laboratory, and some can be measured in both the laboratory and the field.

Laboratory Testing. Some laboratory tests are designed to measure specific basic soil properties like shearing strength or shear modulus, while others

are designed to determine soil behavior in a simulated earthquake environment.

Resonant-column and forced- and free-vibration tests are widely used to determine shear moduli and damping of soil samples.<sup>23,24,25</sup> Ultrasonic pulse tests, in which the wave velocities generated by piezoelectric crystals embedded in soils are measured, can be used to compute dynamic moduli.<sup>25</sup> Cyclic triaxial, simple shear, and torsional shear tests are used in numerous laboratories in both Japan and the United States to evaluate settlement and liquefaction potential.<sup>26</sup>

Centrifugal testing appears to show promise in the study of some aspects of soil behavior during earthquakes, but only a few dynamic tests have been reported.<sup>27</sup> The lack of such tests is due to problems associated with simulating dynamic excitation in the small-scale centrifuge environment, where a shaking table or shaker may be required to perform with a peak acceleration of 50g and frequencies of up to 1,000 Hz in a typical 1/100-scale study, and to the difficulties of measuring response in this environment.

A centrifuge that will have a larger capacity (2,000 g-ton payload capacity) than any existing centrifuge is being developed at NASA/Ames at Moffett Field, California. This centrifuge will be managed by the University of California, Davis, Geotechnical Centrifuge Laboratory, where a much smaller Schaevitz centrifuge has been designed to model the dynamic response of earth embankments, dams, and nuclear reactor sites during simulated earthquakes.<sup>28,29</sup> The smaller centrifuge is being used for testing the performance of a lightweight piezoelectric shaker in order to develop an earthquake simulator suitable for incorporation in the NASA/Ames centrifuge.

The characteristics of ten other centrifuges (of which four have dynamic testing capabilities) are summarized in Appendix D.

Field Testing. Field testing techniques depend on either the measurements of velocities of waves propagating through the soil or the response of soil-structure systems to dynamic excitation.

The seismic refraction survey is a technique suited for general site investigations needed by earthquake engineers. This technique often involves detonating an explosive to generate body waves and measuring the velocity of the generated waves.<sup>25</sup>

An electric sensing probe that can be driven into soil to a fixed depth so that the probe elements contact a sample of the soil to be evaluated has been designed at the University of California, Davis.<sup>30</sup> The probe is equipped with a minicomputer that can be used to measure the properties of soil by passing an electrical current through the soil sample. Various soil parameters, such as stress ratio required to cause liquefaction, friction angle, permeability, and dynamic settlement, are deduced from the electric signal values.

The standard penetration test (SPT) is an accepted means of assessing liquefaction potential in fine to medium sands. The SPT is being used in China and the United States for this purpose.<sup>25</sup>

Crosshole seismic testing is now generally recognized as one of the few reliable methods for obtaining information about seismic velocities, and hence dynamic moduli, of in-situ soils. The method involves generating seismic waves at a particular depth in one boring (energy hole) and recording the arrivals of seismic waves at the same depth in one or more other borings (receiving holes).<sup>24</sup> The mechanisms used to generate seismic waves in crosshole testing programs are discussed in Appendix D. Such a testing technique has been used by Fugro Inc., of Long Beach, California, who carried out five crosshole-type seismic surveys, each employing two commonly used seismic wave generation sources (explosive and mechanical), to evaluate the reliability of each source technique to produce comparable seismic velocities. Each site was the proposed location of a nuclear power station, but soil profiles differed considerably. Comparison of the resulting velocities (compressional and shear) produced by the two different sources indicated that quite similar results can be obtained when proper field and interpretation procedures are used.<sup>24</sup>

Another type of field testing technique has been used by URS/John A. Blume & Associates, Engineers, San Francisco,<sup>31</sup> who obtained a set of attenuation

measurements of shear waves generated at the surface in sandstones and shales on the site of an existing West Coast nuclear power plant. The approach was to observe the decay of amplitude with depth for selected frequency components of shear waves generated at the surface. The downhole pulse, which was generated by a hammer blow, was of the order of 100 Hz. In addition, continuous borehole velocity logs were obtained from a sonde that generated a pulse of about 35 kHz.

Other field techniques used include the resonant-footing technique for evaluating shear modulus of a soil through the use of a torsional resonant footing; the cylindrical in-situ test, which consists of instrumenting a field with accelerometers and detonating explosives in a central hole to measure soil properties and constitutive relations; and the water cannon technique, in which the soil response to an impulse load applied by a water cannon is measured<sup>25</sup> and the impulse created by blasting the water out of the tube with an explosive charge is compared with the vertical response of the system in order to determine the dynamic stiffness of the supporting medium.

Excitation of model footings to produce motions comparable with permissible motions of prototype footings has also been used as a field testing technique. Such a program has been carried out by the U.S. Army Engineer Waterways Experiment Station at Vicksburg, Mississippi, and at Eglin Field, Florida.<sup>32</sup> The results of these tests have been analyzed by Richart and Whitman.<sup>33</sup>

The Central Research Institute of the Electric Power Industry, Japan, has developed a vibration generator for use in measuring the in-situ moduli and damping values of soil. The vibrator is designed to operate over a frequency range of 0.01 to 10 Hz and to generate a maximum inertial force of 50 tons at 10 Hz when embedded in soil.<sup>12</sup>

The 9-story reinforced concrete Millikan Library building at the California Institute of Technology has been the subject of a series of forced-vibration tests to study soil-structure interaction. The amplitudes of motion in the far-field region were recorded along 11 lines radiating from the building and extending to 6.4 km.<sup>34</sup>

The series of vibration tests on the two 4-story test structures at the Nevada Test Site included measurement of the free-field motion in the immediate vicinity of the structures.<sup>35</sup>

The staff of the U.S. Army Engineer Waterways Experiment Station at Vicksburg, Mississippi, has applied forced vibrations to excite embankments and buildings in both horizontal and vertical modes. Transfer functions were evaluated in order to define soil-structure interaction.<sup>36</sup>

#### U.S.-JAPAN LARGE-SCALE RESEARCH PROGRAM

The unexpected heavy damage inflicted by the 1968 Tokachi-oki (Japan) earthquake on numerous reinforced concrete school buildings of modern design underscored the need for a reevaluation of modern building design and construction practices.

In response to this need, a joint seminar under the sponsorship of the U.S.-Japan Cooperative Science Program was held in Sendai, Japan, from September 21 to September 26, 1970, for the purpose of reviewing, in depth, the causes of damage sustained by modern school buildings during the Tokachi-oki earthquake, examining design and construction methods, and identifying and defining needed programs of research that could be conducted more effectively on a cooperative basis. Because of the mutually acknowledged benefits derived from this first seminar, additional joint U.S.-Japan earthquake engineering seminars have been held during the past several years. Through these meetings it became increasingly clear that large-scale testing was needed to establish the merits and limitations of small-scale and component testing and to verify analytical earthquake design prediction procedures. Therefore, at the tenth joint seminar, which was held in Washington, D.C., on May 23 to May 26, 1978, the U.S.-Japan Panel on Wind and Seismic Effects reiterated earlier support for a large-scale testing program and adopted the following resolution<sup>37</sup>:

The Panel on Wind and Seismic Effects recognizes the importance of the U.S.-Japan Cooperative Program on Large-Scale Testing, and it urges early implementation of the program under the auspices of this panel.

A special task committee, with representatives from both the United States and Japan, has been formed to identify practicable goals and objectives for the U.S.-Japan Cooperative Research Program Utilizing Large-Scale Testing Facilities. To date, this planning committee, working under the auspices of the U.S.-Japan Panel on Wind and Seismic Effects and sponsored by the NSF, has held three planning group meetings aimed at identifying specific testing needs and priorities and at establishing definitive test facility operating requirements. The Third Planning Group Meeting, held in Tokyo on December 18 to December 23, 1978, adopted the following resolutions<sup>37</sup>:

1. The goal of the joint program is to improve seismic safety practices through studies to determine the relationship among full-scale tests, small-scale and component tests, and analytical studies.
2. The joint program shall be designed and conducted to:
  - a. achieve clearly stated scientific objectives;
  - b. represent total building systems as realistically as possible;
  - c. balance the simplicity and economy of test specimens with the need to test structures representing real situations;
  - d. maintain a balance among small-scale, component, and full-scale tests;
  - e. utilize previously performed experiments and studies to the extent practical;
  - f. represent the best design and construction practice in use in both countries;
  - g. check the validity of newly developed earthquake-resistant design procedures;
  - h. maintain flexibility to accommodate new knowledge and conditions as successive experiments are completed; and
  - i. assure the practicality of program results.
3. This program should be initiated in 1979 jointly and cooperatively in both the United States and Japan.
4. To implement this program, the establishment of the following committees and working subpanels is recommended for inclusion in the governmental MEMORANDUM OF UNDERSTANDING:
  - a. Joint Executive Committee for the purpose of providing scientific advice to participating institutions in this program and to appoint subpanels other than stated below to perform tasks as agreed necessary;

- b. subpanel for execution of the full-scale and supporting tests for each structural type; and
  - c. subpanel for assessing the feasibility and validity for use in this program of pseudodynamic loading techniques.
5. To implement this joint program, quick and positive response by both governments as to funding and staff arrangements is requested. Strong emphasis is placed on funding the loading systems needed to assure adequacy of the facilities to perform the planned experiments.
  6. The planned order of testing is first the reinforced concrete structure and second the steel structure. Precast-prestressed concrete structures and mixed steel-reinforced concrete structures are the next priorities. Masonry and timber structures should be studied further for inclusion in this program.
  7. Additional tests and analyses found to be required beyond the planned program should be conducted to assure that research results can be applied in the practical design of buildings.
  8. All activities of the joint program (full-scale tests, support tests, analytical studies, etc.) should be conducted cooperatively with balanced participation from both countries to the extent possible.
  9. The 4th Planning Group Meeting, U.S.-Japan Cooperative Research Program Utilizing Large-Scale Testing Facilities, should be held in the United States during the period July 9 to July 14, 1979.

**This Page Intentionally Left Blank**



### 3. NASA/MSFC Test Facilities

The facilities evaluated as part of the three-day site visit and workshop can be conveniently divided into two categories: the MSFC ground-based facilities and Spacelab. Spacelab is not a NASA/MSFC facility per se; however, MSFC is the lead NASA Center for the development of the Spacelab and currently has been assigned mission management responsibilities for the first three Spacelab missions. In view of these considerations, and because Spacelab has been identified both in a previous NSF-sponsored workshop<sup>6</sup> and in a subsequent NASA-sponsored overview study<sup>38</sup> (see Appendix C) as a potential laboratory facility that would provide a new and unique testing environment for conducting basic research on soil behavior relevant to geotechnical earthquake engineering, it was included as part of this evaluation.

#### MSFC GROUND-BASED TEST FACILITIES

MSFC was designed to provide an autonomous environment for testing of large spacecraft and subassemblies subjected to static, dynamic, static-fire, and impact loading. The large size of spacecraft, such as the Saturn V first-stage booster, tested at MSFC has necessitated the development of extensive large-scale testing facilities with computerized load control systems, sophisticated instrumentation and data processing facilities, and a skilled staff of technicians and engineers.

To determine whether the MSFC facilities, which have been used to fulfill the testing needs of spacecraft hardware development, can satisfy the testing needs of earthquake engineering research, it is important to compare the needs of the two experimental research disciplines. For static testing, the needs are essentially the same; that is, both disciplines require that the tests provide information on the amount of load or deformation that a given structural configuration can resist before failing. There are similarities as well as differences in dynamic testing needs, however. Although modal surveys to determine eigenvalues and eigenvectors are important to both disciplines, the physical configuration of modal survey testing differs substantially. For space vehicles, overall mode shapes and frequencies must be

determined for the free-free vehicle configuration. For earthquake engineering, however, virtually all modal survey testing is appropriately performed for a building with a fixed-base or semifixed-base condition. Dynamic testing for the two disciplines differs also in that very little failure testing is done dynamically for space vehicles or components, whereas substantial dynamic failure testing is desirable for earthquake engineering purposes.

#### MSFC Test Equipment

In this review of the NASA/MSFC facilities, the testing apparatus are considered to be suitable for earthquake engineering purposes if (1) they are capable of stroke displacement in excess of 200 mm (with large applied horizontal forces), which is necessary for destructive testing, or (2) they operate efficiently at a frequency range of 0 to 15 Hz, which is desirable for modal excitation of structural or soil systems.

Attention is focused on those MSFC facilities that are unique and that therefore would augment existing facilities used for earthquake engineering research. Descriptions of these unique MSFC facilities are presented below.

A large 43-m-tall structural test tower (strong back) is located in the annex of Building 4619. It has the capacity to apply a load of 1,090 tons horizontally to test structures that range in height from 12.2 m to 35 m and that have a maximum plan dimension of 24.4 m by 15.2 m (assembled under the tower). The structure test stand is composed of a movable vertical load reaction head between four tower legs. The head is situated over a thick steel-reinforced concrete floor with floor tiedowns on 457-mm centers. Five horizontal box plate girders spanning two of the tower legs at 6.1-m intervals up to a height of 30.5 m provide lateral load reaction and walkway access. Biaxial shear loads can be applied to the test specimen using these girders, in conjunction with special-purpose, lateral-reaction test fixtures. The S-1C static test stand (Building 4670) has a similar capability (see Appendix E).

There are many large buildings with open spaces at MSFC. These would be useful for housing model tests of line structures such as bridges and pipelines that occupy large areas. These buildings may also be utilized as test

specimens for full-scale dynamic loading studies. Building 4550 is especially suitable for such studies. The Structural Test Facility for Hazardous Tests (Building 4572) has similar capabilities.

MSFC has a large inventory of hydraulic actuators, which can generate forces ranging from 23 to 1,000 tons. The computerized Automatic Load Control System is capable of controlling up to 56 different load points simultaneously.

The modal special test equipment (modal STE), located in Building 4619, is designed to facilitate performing modal vibration tests, with three-dimensional excitation, of large test specimens. A system of air bags is available to support the base of the test specimen, thus allowing a free-free boundary condition of the specimen to be simulated.

Approximately 28 electrodynamic shakers and 11 hydraulic shakers ranging in payload from 0.02 to 45 tons are available at MSFC for modal testing. The modal control system is a specially designed HP 5451B. It has the unique capability of performing either multipoint sinusoidal or single-point random-type tests. Testing with these shakers is limited to the elastic range because of their small stroke capacities, which are about 225 mm on four of the electrodynamically driven shakers, about 150 mm on fourteen of the others, and about 25 mm on the remainder.

With some modifications, cylindrical rocket fuel tanks, 5 to 9 m in diameter, which are currently being used as structural test articles at MSFC, could, if available, be used as soil test bins. These bins could be used for conducting a variety of soil dynamics tests, including soil-structure interaction tests. The bins could be mounted on the modal STE and excited in a variety of directions (vertical, translational, or torsional) using available shakers.

The neutral buoyancy space simulator, located in Building 4706, consists of a large water tank 22.9 m in diameter and 12.2 m deep. The tank is serviced with special systems for underwater audio and visual links, data acquisition and recording, and environment control. This facility may be used to study the dynamics of soil-fluid-structure or fluid-structure interaction and may be especially useful for studying the dynamic behavior of piles that support offshore structures.

A six-degree-of-freedom motion simulator is located in Building 4663. This unique shaking table has an area of 5.2 m x 4 m and a payload capacity of 10.5 tons. The table motion frequency range is 0 to 10 Hz, with a maximum vertical acceleration of 1.0g and a maximum horizontal acceleration of 0.6g. The horizontal stroke limit is  $\pm 1.2$  m.

The MSFC centrifuge, located in Building 4487, has two modes of operation: (1) vibration and acceleration and (2) acceleration only. The first mode is capable of vibrating a 0.05-ton specimen with an acceleration of up to 28g sine at a frequency range of 5 to 2,000 Hz and 20g random at a frequency range of 20 Hz to 2,000 Hz, while subjecting it to a constant centrifugal force of 20g per unit mass of specimen. These characteristics limit the application of this mode to 1/20-scale for soil-structure models. In the second mode of operation, the centrifuge is capable of producing centrifugal forces of 100g per unit mass on a 0.23-ton specimen without vibrating it simultaneously.

The MSFC grounds have been used to test space vehicles subjected to static-firing and pyrotechnic explosive conditions. The desirability of this site for explosion-generated earthquake-like ground motion studies is enhanced by the fact that the MSFC staff is experienced in the techniques of controlled detonation of explosives. The Redstone Arsenal could be used as a site for studying structural response and soil-structure interaction during simulated earthquake ground motion and for testing geophysical instruments designed to measure dynamic soil properties.

The Geotechnical Research Laboratory, located in Building 4481, consists of a group of experimental systems that, in conjunction with other MSFC dynamic testing equipment, provide unique capabilities for basic and applied research on the mechanical behavior of granular and fine-grained, cohesive materials and for coordination of potential geotechnical earthquake engineering research activities at MSFC.

Figure 1 provides an aerial view of the MSFC ground-based test facilities. A comprehensive description of all the various ground-based test facilities at MSFC is given in Appendix C.



FIGURE 1 AERIAL VIEW OF MSFC

### MSFC Test Support Capabilities

In support of the test facilities, MSFC also has a unique manufacturing capability: it can process materials from raw stock into finished assemblies and systems. This includes machining and processing all types of metals, sheet metal fabrication, welding, and fabrication of wood, plastic, and composite-material articles. In addition, MSFC has the capability of fabricating electrical, electronic, and electromechanical subassemblies, components, and larger articles.

### MSFC Structural Test and Data Acquisition System (STDAS)

Data acquisition and processing is integral to any test facility. The STDAS, located in Building 4619, is large, versatile, and portable and easily serves the many test facilities at MSFC. In addition, it is capable of both dynamic and static test data recording. Although the STDAS is not the only test control and data acquisition system at MSFC, it is highlighted here to illustrate the type of software test support systems available at MSFC.

The STDAS was designed specifically to meet the needs of the structural testing program for Shuttle spacecraft hardware; however, the system can be used for a multitude of similar data acquisition applications as well. Because the Shuttle testing program had not been fully defined at the time the STDAS requirements were specified, maximum flexibility and expandability had to be key factors in the design. This meant that the STDAS had to provide for a wide range of test configurations, transducer types, and data displays.

The system has a total capacity of 6,000 data channels and will accommodate preparation and testing activity for two separate, simultaneous tests. The number of data channels assigned to a given test is determined only by the test requirement, as long as the overall requirement does not exceed 6,000 channels (the system is capable of expansion to 8,000 channels). Up to 48 channels can be monitored in real time during testing, depending on the particular transducers used. The dual-bay input units (250 channels per unit), which are to be positioned at the test sites, are easily transportable and can be moved from site to site as the test requirements dictate. The central processor in Building 4619 will connect to three 2,000-channel remote data acquisition units, located within the building or at remote test sites. The

MSFC communications cable system provides the data link for distances up to 4.8 km from Building 4619.

To support a wide variety of test applications, each data channel can accommodate many types of passive transducers, such as strain gages, pressure sensors, load cells, and displacement, velocity, or acceleration sensors. Active transducers, such as thermocouples, current shunts, and other voltage output devices, can also be accommodated.

Accumulated data can be reduced and displayed while the test is in progress, enabling test operators and stress engineers to have maximum visibility with respect to the condition of the test article and progress of the test. A variety of display techniques is employed to provide this continuous monitoring capability during the test as well as review of recorded data after the test is complete. Predicted and theoretical values for selected measurements can be presented and compared with accumulated data on the same display.

A more complete description of the STDAS is given in Appendix F.

#### SPACELAB

In late 1980, the Space Shuttle will have completed its half-dozen developmental flights and will be ready for routine operations. But routine space transportation in the 1980s will require more than the Shuttle: it will need trained and proficient personnel, as well as facilities and support equipment. The combination of these is called the Space Transportation System (STS).

Spacelab is an orbital facility that provides a pressurized, "shirt-sleeve" laboratory (the module) and an unpressurized platform (the pallet), together with certain standard services (see Appendix G). It is a reusable system that is transported to and from orbit in the cargo bay of the Space Shuttle Orbiter, where it remains throughout the flight. Spacelab extends the Shuttle capability, and the Orbiter/Spacelab combination can be regarded as a short-stay space station that can remain in orbit for up to 30 days (the nominal mission duration is 7 days). In orbit, the experiments carried by Spacelab are operated by a team of up to four payload specialists (men or

women), who normally work in the laboratory, but spend their off-duty time in the Orbiter cabin.

NASA is responsible for overall program planning and management for implementation, and the European Space Agency (ESA) is responsible for design and development of the module and pallets and their associated support equipment. As the lead NASA Center for Spacelab, MSFC is responsible for two major areas of activity: (1) Program Management and Direct Program Tasks consisting of all functions related to the management of U.S. activities; and (2) technical and programmatic monitoring of and assistance to the ESA design and development activities.

The purpose of Spacelab is to provide a ready access to space for a broad spectrum of experimenters in many fields and from many nations. Low-cost techniques are envisaged for experiment development, integration, and operation.

Spacelab offers all the general support that is usually provided for ground laboratories; data processing equipment, utilities, work benches, and floor-mounted racks, all with standard but flexible interfaces, allow easy integration for a multitude of experiments. Other available support includes view ports, extra-vehicular activity, controls and displays, an air lock, film storage, thermal control, manipulators, a computer, and a high-quality window.

In addition to accommodating the needs of individual users, the Spacelab design offers the capability of flying multidisciplinary missions and missions dedicated to a particular discipline, such as materials processing or life sciences. A summarization of the principal resources and capabilities available to payloads using Spacelab is presented below.

- Crew size - 1 to 4 payload specialists
- Payload weight (experiments + 50% mission-dependent equipment) - 5,500 to 9,100 kg
- Total pressurized volume - 5 to 22 m<sup>3</sup>



- Average power (payload + mission-dependent equipment) - 3.0 to 5.0 kW
- Energy - 200 to 580 kWh
- Data transmission
  - down link - 50 mBPS digital, 4.5 MHz analog/video
  - up link - 2 kBPS commands
- Data recording - 30 mBPS digital
- Environment control - 4 to 5.6 kW heat rejection

Another way of flying Spacelab payloads is to employ a facility approach, using a Spacelab double rack configuration (see Appendix G). A dedicated facility approach may be employed for single-discipline payloads, with one user or experiment developer providing the hardware and many users sharing the facility to perform scientific investigations.

The facility approach to Spacelab payloads has a number of distinct advantages. With the development of facility payloads, NASA and ESA can open the door to a much wider body of scientists, who will be able to take advantage of the space environment to conduct their studies without having to develop extensive and expensive instrumentation. Another advantage of the facility approach is that it provides the ability to react quickly to scientific information gained in a given flight and to plan the next flight to conduct the follow-on experiments.

The modular design of Spacelab allows the pallet to be utilized as a facility to accommodate either single- or multiple-discipline payloads. Pallet segments can be flown in conjunction with either the short or long module, as individual pallets flying as part of a mixed cargo on a given Shuttle flight, or combined with other pallets as part of a Spacelab pallet-only mission.

On the basis of work done to date<sup>6,38</sup> and the Geotechnical Committee report (Chapter 5) it appears that, initially, basic research on soil behavior conducted in space will utilize small test facilities, will require payload specialist support, and will require low gravity. Future flights may involve

larger automated facilities, some of which will utilize the very low vacuum of space.

Descriptions of the Spacelab elements that can accommodate the facilities needed for in-space research are included in Appendix G and in Reference 39. Maximum utilization should be made of the Spacelab hardware in order to reduce the cost of orbital activities. Additional data describing Spacelab capabilities is available in the Spacelab Payload Accommodation Handbook (SPAHL), copies of which can be obtained from MSFC.

The earliest flight opportunity for conducting tests in a low-gravity environment is the Spacelab 3 mission. This mission is presently planned for flight in April or May of 1982. Geotechnical research facilities can be accommodated in the racks or pallets on this mission. However, flight hardware must be available for integration into the Spacelab by September 1, 1981. Mission planning indicates that flight opportunities of this type will occur at least once per year. Other flights may also be able to satisfy the requirements for geotechnical research, even though they are not dedicated to low gravity.

As definition of the earthquake-related or other basic geotechnical research facilities and orbital activities progresses, it will be necessary to reserve flight opportunities on Spacelab missions. Geotechnical research payloads can then be considered in mission planning and definition activities. Flight opportunities will be identified in the desired time period to satisfy flight requirements.

A more detailed description of the functional and operational capabilities of Spacelab is given in Appendix G. Figure 2 shows a mock-up of the Spacelab module.

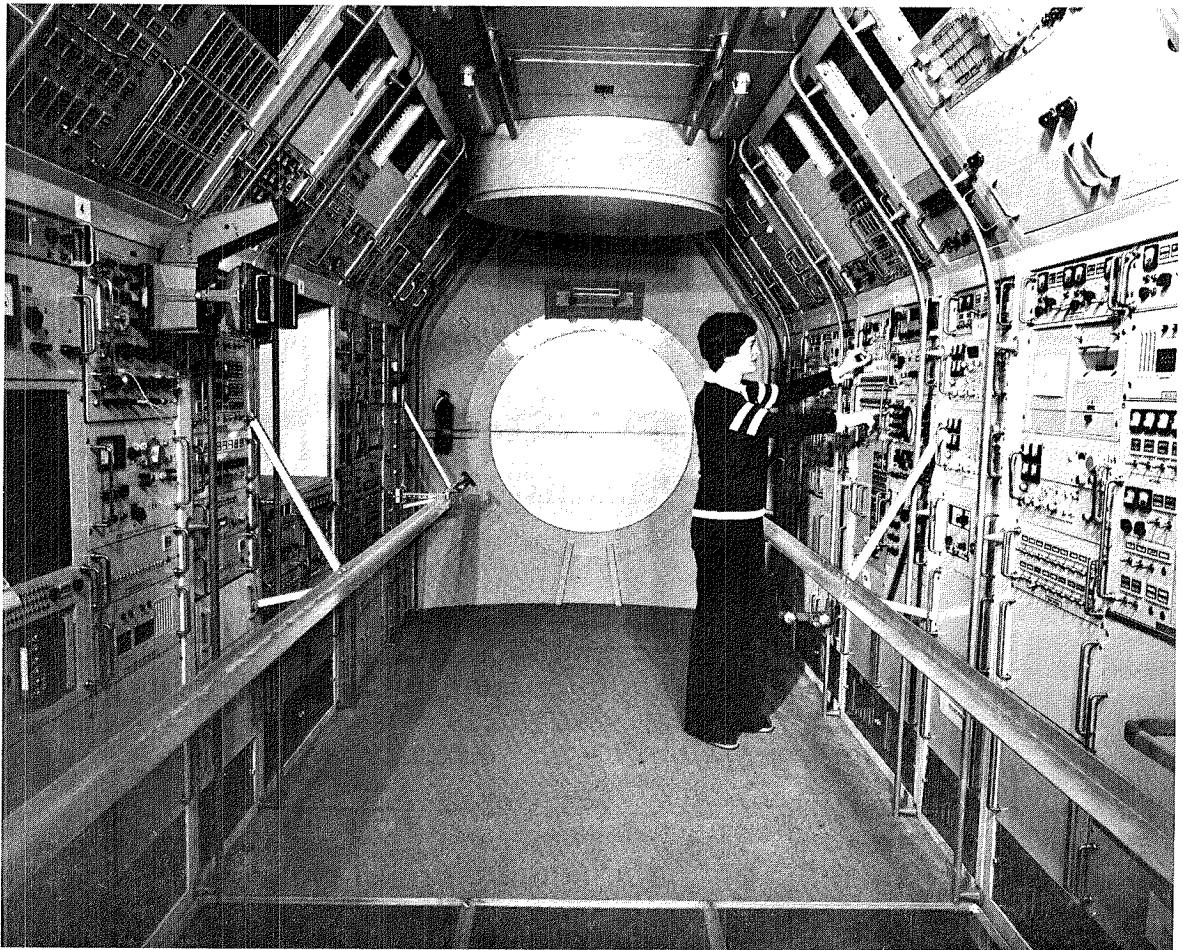

FIGURE 2 MOCK-UP OF SPACELAB MODULE

**This Page Intentionally Left Blank**

## 4. Report of the Structural Committee

The Structural Committee\* report is confined to the potential utilization of those MSFC facilities that are unique and that would augment existing facilities used for earthquake engineering research. The following MSFC facilities are considered to be unique:

- The large 43-m-tall structural test tower
- The automatic load control and data acquisition systems
- The six-degree-of-freedom shaking table
- The modal special test equipment (modal STE)
- The inventory of electrodynamic and hydraulic shakers
- The inventory of hydraulic actuators
- The MSFC/Redstone Arsenal

These unique MSFC facilities have a potential for application to large-scale testing programs involving either full-scale testing of buildings or reduced-scale testing of massive structures. Full-scale tests are favored over reduced-scale tests because at reduced scales it is difficult to simulate the performance of structural details, including the tensile strength of concrete and the characteristics of the bond between reinforcing steel and concrete. For massive structures, however, reduced-scale testing is desirable because of the difficulty of conducting full-scale destructive tests of such large structures.

Several earthquake engineering research programs that could benefit from the availability of the MSFC facilities are presented below in order of priority. These suggested research programs should supplement current earthquake hazard mitigation research activities and not replace them. If appropriate additional funding for such programs becomes available, the research program that has been assigned the highest priority, full-scale building tests, should be of great

---

\*Committee members: W. Iwan, Chairman; R. Hanson, Assistant Chairman; W. Corley, Secretary; M. Agabian; R. Clough; J. Fitzgerald; J. Harris; I. Pendergast; M. Sozen; A. Gerich; and V. Bertero.

interest to several government agencies and, therefore, should be strongly considered for implementation.

#### STATIC-CYCLIC LOAD TESTING OF FULL-SCALE BUILDINGS

Full-scale destructive static-cyclic tests need to be performed on various building types to verify and improve their seismic performance. Testing facilities in Buildings 4619, 4572, and 4670 were evaluated for this purpose. The tall structural test tower located in the annex of Building 4619 has a biaxial lateral load capacity of 1,090 tons and is considered the most attractive facility for such testing. The MSFC structural test tower is a unique static-cyclic loading facility.

The test tower has the capability for performing static-cyclic loading tests on full-scale building systems similar to the tests proposed for the U.S.-Japan cooperative test program. The MSFC tests, however, could utilize the biaxial lateral loading capability of the test tower, whereas the Japan test will be restricted to uniaxial lateral loading. The MSFC and Japan (Tsukuba New Town) test capabilities are compared in Figure 3.

Other desirable facilities are also available in the annex of Building 4619, including the large test-bay area and the test-pad floor with tiedowns at 457-mm centers; the two 27.3-ton-capacity overhead cranes; the inventory of shakers; the modal STE backup; the automatic load control and data acquisition systems, a computer system suitable for feedback-controlled load application; and electrical, electronic, and mechanical shop support with manufacturing, fabrication, installation, and some design capabilities.

A large inventory of actuators already exists at MSFC. However, the purchase of at least four new actuators, each having about a 1.2-m-stroke maximum and a 90-ton capacity, would be required in order to use the Building 4619 annex effectively for full-scale building studies.\*

---

\*According to information obtained by MSFC from three prospective vendors since the workshop, hydraulic actuators meeting these specifications are readily available for a cost of less than \$8,000 each, including verification testing by the vendor. Servo-valve control equipment and the hydraulic source necessary to provide required cyclic capability currently exist at MSFC.

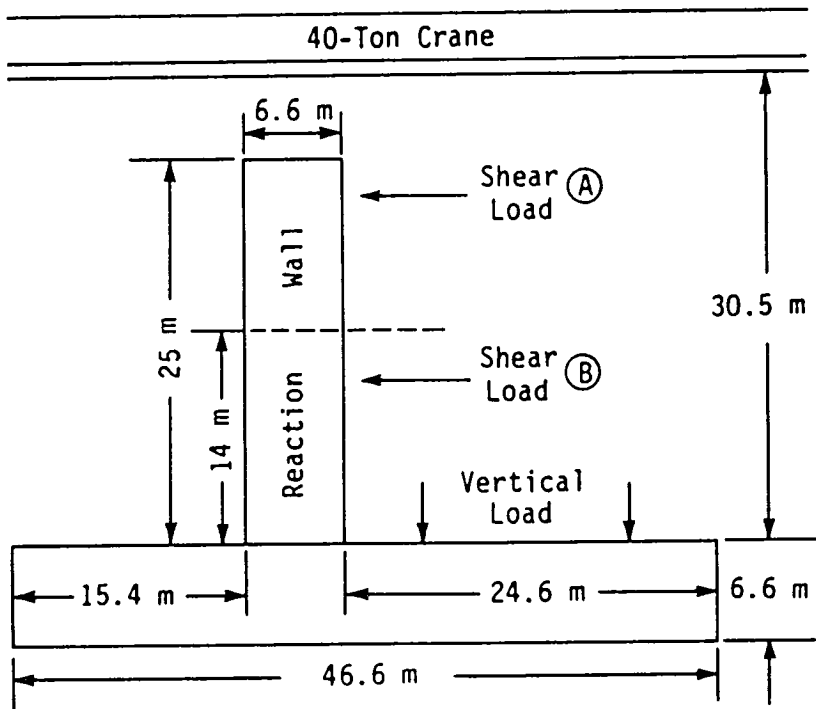

Tsukuba New Town Large-Scale Test Facility

Shear Load (uniaxial) -

- (A) 1,600 tons
- or
- (B) 4,000 tons

Vertical Load -  
4,000 tons

Data System -

Static Strain: 500 channels  
Dynamic Strain: 30 channels  
(see Appendix D, page D-5)

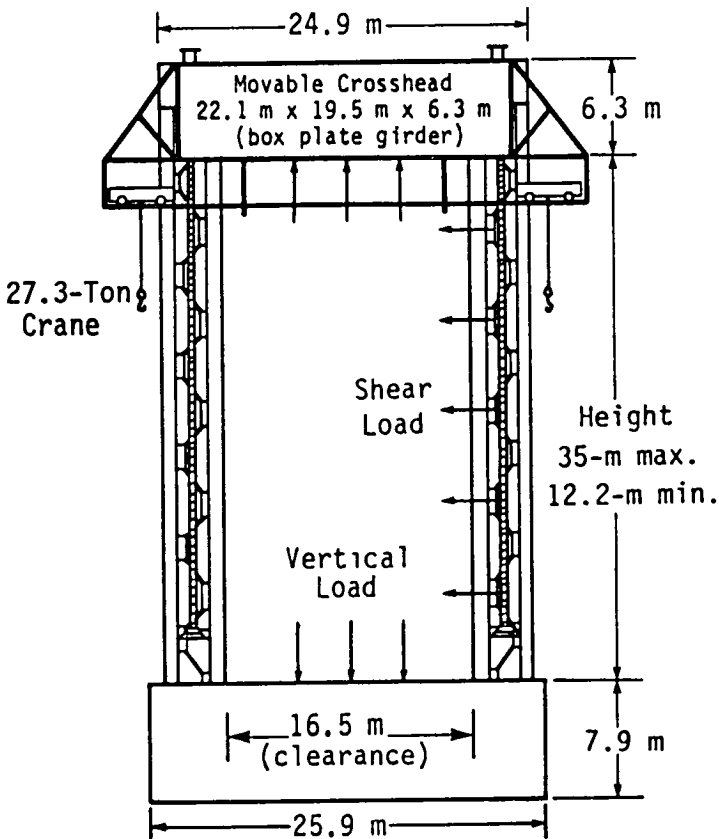

MSFC Static Structural Test Tower (Building 4619)

Shear Load (biaxial) -  
1,090 tons

Vertical Load (compression) -  
13,608 tons (30,000 kips)

Data System -

6,000 channels (see Appendix F)

Maximum Plan Dimension of  
Test Structure -

24.4 m x 15.2 m

(see Appendix E, page E-10)

FIGURE 3 COMPARISON OF STATIC-CYCLIC TEST FACILITIES:  
TSUKUBA NEW TOWN AND MSFC

In most static-cyclic loading tests, repeated reversed lateral forces are applied incrementally in a preselected fixed pattern. An advantage of using this method is that, after each cycle, the building can be subjected to either free or forced vibration by means of shakers, thereby making it possible to measure, at each time step, the relationship of period and damping to the amount of damage induced in the building. The most obvious drawback of using this method is that time-dependent effects are not simulated and that therefore a rather subjective decision must be made with regard to the loading (or deformation) history to be applied to the test structure.

A recently proposed alternative<sup>40</sup> method of performing static-cyclic loading tests is to employ a feedback system between a computer and the actuators. The computer receives the electronically measured characteristics of the test structure, computes the incremental response of the specimen to a predetermined ground motion, and feeds the response increment back to the electronically controlled actuators. In this manner the loading history will follow closely that which is expected when the test specimen is subjected to the assigned earthquake. This feedback system appears to be quite feasible; however, it may become rather complex for three-dimensional structural assemblies with several translational degrees of freedom because it may require a series of actuators and extensive instrumentation.

To gain the information needed for improving structural design, much thought will have to be given to the loading histories for two- and three-dimensional load application because it is very difficult to draw general conclusions from tests with specific loading histories.

Different types of buildings representative of good current design and construction practice should be subjected to destructive static-cyclic loading tests. The following six structural types are suggested:

- reinforced concrete
- structural steel
- precast-prestressed concrete
- mixed steel-reinforced concrete
- masonry
- timber



The test structures could include nonstructural elements such as curtain walls, partition walls, and piping and should be loaded in such a way as to develop and define realistic seismic behavior. After initial testing, the building could be repaired and retested to assess the effectiveness of repair procedures.

Long-range plans could include the possibility of testing large-scale structures other than buildings.

### RESPONSE OF FLUID-FILLED TANKS

During the June 1978 Miyagi-ken-oki earthquake in Japan, three large tanks at the Sendai Oil Refinery failed, spilling approximately 18 million gallons of oil.<sup>41</sup> On a number of other occasions, cylindrical steel oil-storage tanks at pumping plants and refineries have been damaged by earthquake ground motion. Tank shells have deflected vertically, as well as horizontally, as much as 25 mm as a result of earthquake-induced fluid-structure interaction.<sup>42</sup> Such events emphasize the need for an improved understanding of the seismic response of fluid-filled tanks.

To design a fluid storage system that will maintain its integrity during earthquakes, test loading of such structures must simulate at least the three translational components of ground motion associated with earthquakes. Rotational excitation components may also be found to be important.

The existing six-degree-of-freedom motion system located in the high-bay area on the first floor of Building 4663 is a unique facility for performing destructive dynamic tests of fluid-structure interaction systems. The test table has a considerable amount of travel in translation ( $\pm 1.2$  m horizontal) and rotation ( $20^\circ$  to  $30^\circ$ ) and a horizontal acceleration capability of  $\pm 0.6g$  ( $\pm 1.0g$  vertical). This sophisticated shaking table would be useful for testing a variety of tank systems, including cryogenic tanks that simulate liquid natural gas (LNG) containers.

Additional features that make this testing practicable are the automatic load control, monitoring, computer interface, and data acquisition systems located in the motion system control room adjacent to the high-bay area;

surplus fuel tanks suitable for containing liquids or gases during some types of testing; an overhead crane; and staff experienced in hazardous test procedures.

The extensive inventory of electrodynamic and hydraulic shakers in combination with the modal STE located in Building 4619 may also be used for dynamic tests of fluid-structure interaction. Although the shakers will be restricted to modal testing because of the limited horizontal displacement range of the modal STE ( $\pm 37$  mm), the use of modal testing in conjunction with destructive testing is desirable (see the previous section on static-cyclic load testing).

The information determined from fluid-structure interaction testing can be subsequently employed to establish or verify analytical shell-buckling procedures. The influence of initial geometric imperfections and the interaction of flexural and in-plane stresses on the ultimate capacity could also be determined.

#### SHAKING TABLE TESTS

Because shaking tables are capable of accurately reproducing earthquake ground motion recorded from past earthquakes or from artificially generated earthquakes, they are uniquely useful facilities for earthquake hazard mitigation research. However, all the shaking tables in use today have mechanical limitations that restrict their application to only one horizontal component and the vertical component of motion and to prefailure testing (see Appendix D).

MSFC has adequate power supplies, actuators, and foundation structures, and adequate data acquisition systems, for a small (5-m x 5-m) unidirectional shaking table. Additional actuators are required for a similar table with two simultaneous horizontal components and the vertical component of motion and a frequency range of 0 to 300 Hz.

A large (15-m x 15-m) shaking table with two horizontal components of motion, a frequency range of 0 to 25 Hz, and about a 300-mm stroke could be designed and constructed in Building 4619 or Building 4550 for large-scale destructive testing of buildings.

Although the MSFC data acquisition system is adequate for a shaking table of this size and capability, the actuators and power supplies are not. Therefore additional equipment purchases are necessary.

#### ELASTIC RESPONSE OF LARGE PIPING AND OTHER LINE SYSTEMS

A testing program could be initiated to measure the elastic response of large piping systems and other line systems such as bridges to phased multipoint excitation. Building 4550 is readily adaptable to this type of study and is particularly suitable because it has the necessary space and support services to accommodate these large systems. The existing control and data acquisition system is suitable for controlling the loading and recording the data for these tests. In addition, the number and capacity of vibration generators at MSFC and the flexibility of their deployment combine to make this project feasible.

Large piping systems are currently being designed to resist floor acceleration response spectra derived by enveloping all the floor spectra appropriate to the numerous individual support locations. A continuous piping system may have supports located at different story heights or in adjacent buildings of significantly different flexibility. Because the floor acceleration response spectra for the various supports may differ considerably in both spectral content and amplitude, it is important to evaluate the effect of enveloping these spectra. Phased multipoint excitation of the supports of such line systems could be performed, and the response could be compared with that computed from analytical methods that assume uniform excitation.

#### SYSTEM IDENTIFICATION STUDIES (DAMAGE ASSESSMENT)

A research program is needed to determine the dynamic effect of removing or modifying elements of highly redundant systems, such as offshore structures, for which earthquake damage inspection is likely to be difficult due to access constraints. This testing concept is also useful for evaluating redundancy in the earthquake-resistant design of buildings. In the opinion of some investigators, redundancy appears to be a practicable means to achieve fail-safe earthquake-resistant construction.

An experimental research program would involve the application of single-point excitation to the structural systems. The loading level would be restricted to the elastic range. The dynamic characteristics of the structure, such as natural periods, mode shapes, and damping coefficients, would be measured, and then the system would be reconfigured by the removal or modification of some elements. The loading would be then reapplied and the change in dynamic characteristics measured. This process could be repeated until the structural integrity is lost.

The purpose of this research program would be twofold: (1) to trace the collapse mechanism, thus making it possible to identify those members that might be damaged during an earthquake; and (2) to establish the dependence of the dynamic characteristics of the structure on the properties of particular elements. It is anticipated that such a research program would be useful in determining the extent of damage to critical elements in the event of severe earthquake loading of offshore structures, foundation beams, and other such structures for which inspection is difficult.

The availability of numerous shakers, actuators, and transducers at MSFC, together with the capacity of the load control and data acquisition systems, makes such a program practicable. Building 4550 could provide the large space and support services necessary to test complex systems.

#### EXPLOSION-GENERATED EARTHQUAKE-LIKE GROUND MOTION STUDIES

Conventional high explosives or nuclear explosives can be detonated underground to produce a wave propagation environment with earthquake-like ground motion amplitudes and frequencies. Control of this environment -- that is, control of amplitude, frequency, and duration -- is possible through enhancement techniques<sup>17,18</sup> such as sequential firing, geographic distribution of blasting arrays, and construction of such barriers as relief trenches to obtain advantageous reflections of propagating waves.

The MSFC/Redstone Arsenal is a potential site for testing full-scale structures subjected to explosion-generated earthquake-like ground motion. Space is available for construction of test structures or even a test "city" made up of a variety of test structures and facilities. Furthermore, the staff

employed at the arsenal is experienced with the technical and safety aspects of controlled explosion detonation. The central data acquisition system would have sufficient capacity to record and process the test data, which may be conveniently transmitted through the field-traversing instrumentation cable.

Previous underground explosion structural studies have been generally confined to elastic testing of three- and four-story full-scale reinforced concrete buildings,<sup>20,43</sup> and therefore the scope for further studies is extensive. Because other sites for such studies exist, further feasibility studies are required to evaluate the merits of the potential application of the MSFC/Redstone Arsenal site to earthquake hazard mitigation research.

**This Page Intentionally Left Blank**

## 5. Report of the Geotechnical Committee

The Geotechnical Committee\* report is confined to the utilization of those test facilities at MSFC that have a unique potential for medium- to large-scale model testing as well as a unique ability to monitor and process substantial quantities of laboratory or field data. High-capacity load and vibration devices, isolation equipment, and recording devices are available in abundance. Also, a number of buildings with large, open spaces especially designed for model testing can be used. These facilities cannot be duplicated at any existing institute or university without enormous expense. In addition, the MSFC/Redstone Arsenal site is a unique field laboratory. Finally, MSFC has an existing geotechnical laboratory (see Appendix E); therefore local competence is available for coordination of research activities.

Researchers developing methods to investigate soil response to seismic loading and to evaluate ground properties prior to and following seismic shaking would find the capabilities of MSFC attractive. The management of the research and the interpretation of the results would be done by, or under the direction of, the independent principal investigator. MSFC would provide facilities and capabilities as needed by the researchers.

The results of the Geotechnical Committee's evaluation of the MSFC facilities are summarized in the following subcommittee reports. The findings are described under two broad categories: experiments useful in the study of the dynamic behavior of soils and earth structures and experiments involving the dynamic interaction of soils and structures. In addition, the possible development of field services to aid both efforts is discussed.

A completely distinct facility is Spacelab, which will make it possible to conduct unique investigations of soil properties and behavior in a zero-gravity environment and under sustained high-vacuum conditions. The use of

---

\*Committee members: G. Castro, J. Christian, W. Clough, J. Costello, R. Dobry, J. Mitchell, F. Richart, J. Roesset, D. Sangrey, M. Silver, and R. Woods.

this new capability is discussed in the in-space soil behavior subcommittee report.

## DYNAMIC BEHAVIOR OF SOILS AND EARTH STRUCTURES\*

### Laboratory Model Soil Testing

MSFC has unique facilities available for conducting various soil behavior and earth-structure experiments valuable to earthquake engineering. The types of testing that can be performed with these facilities are:

- Soil bin testing
- Shaking table testing
- Centrifuge testing

Soil Bin Testing. Rocket fuel tanks currently being used at MSFC as structural test articles could be used, if available, as test bins for conducting soil tests. Several small bins (approximately 5 m in diameter and 9 m deep) and one large bin (approximately 9 m in diameter and 5 m deep) could be built using these fuel tanks. A photograph of a rocket fuel tank section that could be used as a large bin for soil testing is presented in Figure 4.

The bins could be used to perform relatively large-scale testing for the following research projects:

- Studying the settlement of dry sands under three-dimensional shaking
- Studying the liquefaction of saturated soil masses under three-dimensional shaking (the sand could be homogeneous or stratified)
- Studying soil behavior under repeated excitation (simulating consecutive series of earthquakes)
- Evaluating different methods for reducing liquefaction potential (e.g., densification by vibraflo-tation, terraprobe, etc.)
- Evaluating in-situ soil-testing devices<sup>44</sup>

---

\*Subcommittee Chairman - M. Silver; Secretary - W. Clough.



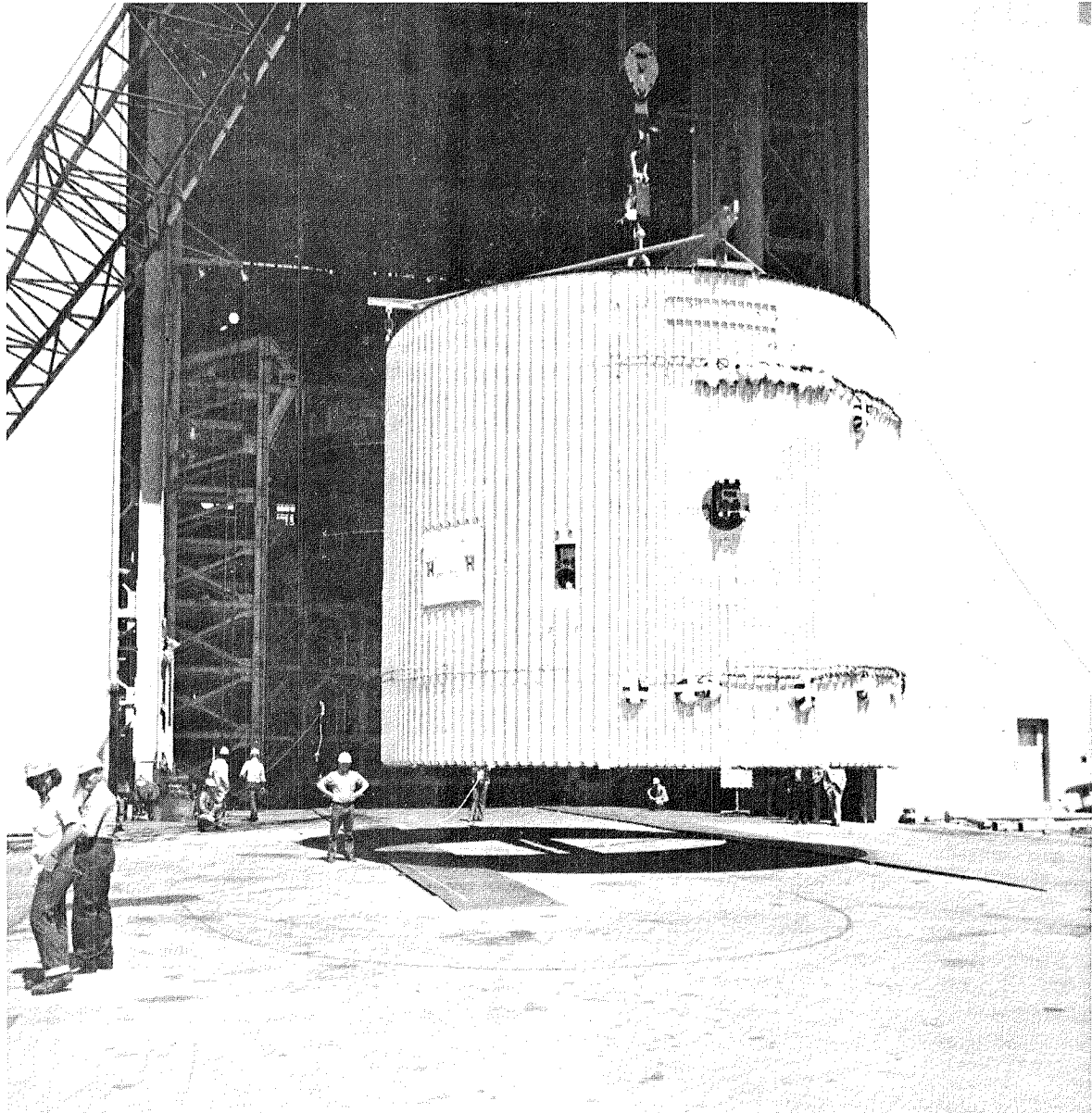

FIGURE 4 ROCKET FUEL TANK SECTION BEING READIED FOR STRUCTURAL TESTING

- Developing methods to measure in-situ soil characteristics such as dynamic moduli and change of pore water pressure during seismic excitation of in-situ soil structures
- Investigating soil-structure interaction through the use of model tests

Desired features of the bins include three-dimensional shaking capabilities, ability to handle dry and saturated soil, and a capacity for externally induced vertical hydraulic gradients (with or without simultaneous shaking). In addition, torsional shaking as an alternative to translational shaking in the horizontal directions could be a very useful mode of excitation.

Building 4619 would be a good location for the soil-test bins. The modal STE could be used to support the bins, various available shakers could be used to excite the bins, the Automatic Load Control System could be used for test control, and the STDAS could be used for data acquisition and analysis.

Some special reinforcement of the bins may be needed, but this should not be a significant expense. In addition, although hoists for heavy lifting are available, special devices for placing the sand in a uniform density would have to be built or leased.

Shaking Table Testing. The existing six-degree-of-freedom motion simulator (shaking table) has a payload capacity of 10.5 tons, an area of 5.2 m x 4 m, and a motion frequency range of 0 to 10 Hz. Application would be limited to modal studies or to medium-scale (1/2- to 1/10-scale) destructive testing of systems for which the assumption of lumped-mass modeling of body forces due to gravity is not critical (e.g., rock-fill dams). Use of this shaking table would enable the ultimate capacities of these systems under earthquake conditions to be investigated.

The construction of a large (12-m x 12-m) multidirectional shaking table with a payload capacity of 500 tons is recommended. Model tests of dams, slopes, cofferdams, and reinforced earth structures could be conducted on such a facility. Building 4619 is a suitable location for this shaking table because of its spaciousness and the service facilities available there. It is believed, however, that dynamic actuators at MSFC do not have the capac-

ity to excite a table of this size. Thus, new actuators would have to be acquired.

The large shaking table would be useful in vibrating a large soil mass, the behavior of which could be monitored under three-dimensional shaking applied at the base of the table. In terms of soil behavior, the following could be addressed:

- Settlement of dry sands under three-dimensional shaking.
- Liquefaction of saturated soil masses under three-dimensional shaking (the sand could be homogeneous or stratified).
- Model tests of dams, slopes, cofferdams, and reinforced earth structures subjected to earthquakes.

Centrifuge Testing. The centrifuge existing at MSFC has two modes of operation: (1) vibration and acceleration and (2) acceleration only (see Chapter 3 and Appendix E). The present characteristics of the centrifuge limit the application of the first mode to 1/20-scale models. The second mode of operation is capable of producing centrifugal forces of 100g per unit mass on a 0.23-ton specimen. It is desirable to develop a lightweight shaking table capable of simulating 1/100-time-scale earthquake conditions within the centrifuge. This modified system would be useful for destructive testing of small-scale (1/100-scale) systems for which the correct modeling of stress distributions due to large gravitational body forces and external tractions is important (e.g., embankments).

#### Field Testing of Dynamic Soil Behavior

Site characterization experiments could be performed at MSFC to test tools designed to characterize in-situ subsurface conditions. Loading devices or geophysical instruments<sup>44</sup> for measuring dynamic soil properties could be tested. This could be done in conjunction with the field tests being proposed to study soil-structure interaction (see the following section). The site characterization study could be performed at the same site as the field tests to provide correlation information.

Information about the geological characteristics and engineering properties of the MSFC subsurface conditions would be required before the site characterization experiments and many of the soil-structure interaction studies can be undertaken. Much of this information has already been obtained through various construction projects at MSFC and the Redstone Arsenal; see Reference 45, for example.

#### DYNAMIC SOIL-STRUCTURE INTERACTION\*

##### Field Testing

Important research in soil-structure interaction involves field testing. Such testing is needed to validate analytical solutions for the response of surface and embedded foundations subjected to excitation applied directly to the foundation or transmitted through the soil.

The grounds of MSFC would be uniquely suited for field tests involving soil-structure interaction for a number of reasons. The availability of large-amplitude vibration exciters, numerous vibration pickups, and many channels of data acquisition and computer evaluation make comprehensive field tests possible. In addition, heavy equipment is available for transporting testing equipment on the site.

The site itself has residual soil overlying rock. The soil is of varying thickness, but preliminary information indicates that depths up to 15 m are available. The soil characteristics must be carefully evaluated, but the actual values are of secondary importance because analytical solutions can be adapted to model the actual conditions. Reference 45 indicates that the soil compression wave velocities at a Redstone Arsenal site adjacent to MSFC are approximately 300 to 425 m/sec for the first 5 m of depth, 900 to 1,100 m/sec for a depth of 5 to 12 m, and 2,300 to 5,000 m/sec below a depth of 12 m. In-situ tests on undisturbed soil at the same site indicate a primary natural frequency of 53 Hz and a damping ratio in the horizontal plane of 0.043. Figure 5 shows that the depth of the surficial material varies considerably throughout MSFC; thus, an appropriate site for conducting soil-structure interaction tests would have to be determined from exploration.

---

\*Subcommittee Chairman - F. Richart; Secretary - J. Roesset.

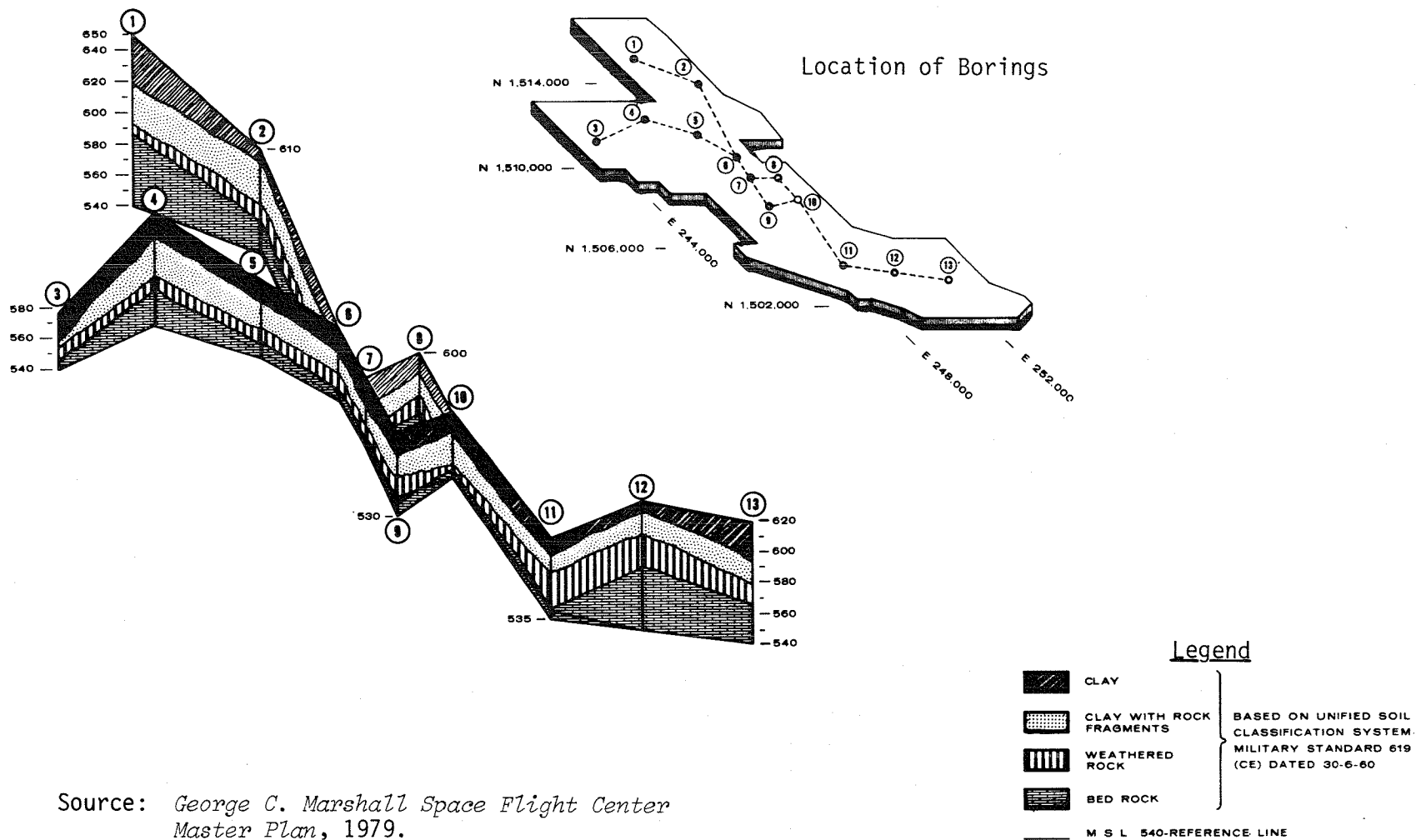

FIGURE 5 GEOLOGY UNDERLYING MSFC

Three specific types of soil-structure interaction research projects that involve field testing could be performed at MSFC. These research projects would utilize vibration generators available at MSFC to excite structures of interest, and the STDAS could be used to monitor the structure and the near-field soil response. Arrays of underground explosions could also be detonated at the Redstone Arsenal to generate earthquake-like ground motion required for input to soil-structure interaction studies. The proposed research projects, which are discussed in detail below, are:

- Effect of embedment on mat foundations
- Interaction between adjacent structures
- Dynamic response of pile foundations

Effect of Embedment on Mat Foundations. It is proposed that tests be performed to determine the effect of embedment on the dynamic response of rectangular or circular mat foundations, accounting for various conditions of backfill.

A variety of sophisticated and simplified procedures have been developed in the past several years to estimate the motions of an embedded foundation caused by a specified train of seismic waves (often referred to as the kinematic interaction problem) and to determine the foundation stiffnesses (needed for the solution of the inertial interaction problem). A basic limitation of these solutions is that either they assume generally linear soil behavior or they approximate nonlinear effects through equivalent linearization techniques. It can be shown, however, that the engineering properties of stiffness and damping are very sensitive to the actual conditions of the backfill. An experimental verification of the analytical predictions is badly needed, but it requires operating on a large field site in order to avoid introducing box effects (reflection effects) that would mask the radiation damping.

Interaction between Adjacent Structures. It is proposed that studies be undertaken to determine the interference or interaction between two adjacent mat foundations, either surface or embedded, as a function of the wavelength of generated Rayleigh waves relative to the distance between the foundations.

A limited number of analytical studies have been conducted to date in order to assess the effect of adjacent structures. Many of these solutions are limited by the assumption of linear elastic behavior. It is clear, however, that under large excitations the interference phenomena between two close foundations are largely affected by the local soil behavior, which will be anisotropic and inhomogeneous. Therefore, a realistic evaluation of structure-soil-structure interaction effects requires experimental verification by field tests.

Dynamic Response of Pile Foundations. It is proposed that research be conducted to determine the dynamic response of pile foundations (a pile group versus a single pile).

Research on the dynamic response of piles is much less abundant than research on the dynamic response of mat foundations. Several analytical solutions (based mostly on linear elastic soil behavior) are now available for isolated piles, but results for pile groups or complete pile foundations are just beginning to appear in the literature. The interference or group effect between piles is very hard to assess analytically, and it is especially difficult to analyze the effects of nonlinear soil behavior.

A number of dynamic and static loading tests on full-scale single piles have been and continue to be conducted. However, few of these tests include complete identification of dynamic soil properties. Dynamic field tests of complete pile foundations are rare because of the large forces required and the lack of an adequate loading capability.

Field Testing Procedures. For each of the above-mentioned testing projects, it would be desirable to begin with small levels of excitation where the soil behavior might still be linear. The excitations could gradually be increased until levels of strain in the soil are comparable to those that occur during earthquakes. This is particularly important in assessing the real behavior of embedded foundations (backfill effects) and the interaction between adjacent structures under seismic loading.

It would also be desirable (1) to apply an excitation directly to the top of the foundation (or foundations) and (2) to propagate a train of waves

through the soil. In the latter case, a variety of waves could be generated. Rayleigh waves would be of interest because the effect of the bedrock can be minimized by confining the waves to a soil layer with a depth of approximately 15 m.

Two types of loading are recommended for the proposed research projects: the excitation should be either harmonic (e.g., vibration generator) or it should follow an arbitrary time history, or spectrum, that reproduces a simulated earthquake record (e.g., controlled array of underground explosions).

In addition to the information gained by testing specially built foundations at the field test site, valuable knowledge can be obtained by applying forced vibrations to some of the existing MSFC structures (e.g., some of the towers) and instrumenting the structures, their foundations, and the surrounding soil. The magnitude and nature of soil-structure interaction effects for these structures can then be evaluated and compared with analytical predictions.

Further studies on soil-structure interaction could also be conducted in combination with structural research if full-scale masonry or prefabricated panel buildings (massive and stiff construction) were to be built and tested on the Redstone Arsenal site, instead of erecting and testing them inside one of the buildings. This effort is related to the recommendation of the Structural Committee for dynamic tests of buildings under explosion-generated ground motions. However, to assess interaction effects, a controlled wave source, harmonic or according to a specified earthquake-like frequency content, is desirable. Further development work may be necessary before such a wave source can be reliably generated from underground explosions.

Timing and Organization for Soil-Structure Interaction Field Testing. If a field site for soil-structure interaction testing were created at MSFC (Redstone Arsenal), a testing program spanning a period of five years should be established. Determination of the soil profile, evaluation of the static and dynamic characteristics of the soil, and selection of a specific test site would require a year of preliminary studies.

Because of the magnitude of the testing program contemplated, it would appear that an analytical effort of the same nature should be conducted in parallel:



this implies analytical predictions, interpretation of the test results, refinement of analytical models, and derivation of recommendations for analysis and design procedures. This kind of effort necessitates obtaining the cooperation of several researchers at various universities.

Supervision of the experimental program will also require some careful coordination. A competent soils engineer would have to be in residence at MSFC to control the day-to-day operations related to excavation, placing and compacting of the backfills, and construction of the foundations. Local competence is available through the Geotechnical Research Laboratory (see Appendix E). Graduate research assistants from the universities participating in the project could contribute additional supervision through stays of several months at the site, and the principal investigators would have to schedule periodic visits of several days' duration.

#### Laboratory Testing

Studies on soil-structure interaction effects could be conducted using a model embedded in a large soil bin that can be shaken in both vertical and torsional modes. The general characteristics of this large bin are described in the soil behavior and earth structures section above. While this method of performing soil-structure interaction testing appears promising because of the large bins available at MSFC, further feasibility studies are needed. The specific MSFC facilities that make this method of testing feasible are the test bins, the modal STE, the STDAS, and the dynamic exciters.

#### FIELD SERVICES FOR DYNAMIC STUDIES OF SOILS AND SOIL-STRUCTURE INTERACTION

Most problems in soil dynamics are studied at particular sites with specific types of soils and geologic environments. The field site at MSFC is necessarily limited to a single set of conditions created by the geologic history of the region. Although significant field research could be done locally at the MSFC site, the restriction of field activity to one site clearly limits the range of problems that can be addressed.

It is necessary to go into the field to measure the behavior of such structures as existing dams and offshore oil platforms and to investigate the

effect of locally complex geologic conditions. A unique asset of MSFC is the quality and quantity of instrumentation, data acquisition, and loading capability. If some of this capability could be transported to remote sites to perform field services, it would contribute substantially to the task of evaluating the vulnerability of existing structures to earthquake damage. This scheme does not require the use of remote data processing.

Many of the significant advances in earthquake engineering will be derived from evaluated field experience both during actual earthquakes and in planned field experiments. An MSFC field service could become an essential part of such research.

The anticipated mode of operation would emphasize the effort of a principal investigator not affiliated with NASA and would use MSFC field services during the period of actual experimental activity only. It is important to define a management plan that would allow access to a broad group of principal investigators and would make the field services available at a reasonable cost.

#### IN-SPACE RESEARCH ON SOIL BEHAVIOR\*

The unique ability to conduct long-duration experimentation in a manned laboratory facility in space offers potentially significant opportunities for geotechnical research. The greatest potential for Spacelab experiments resides in the explanation of the fundamental phenomena of soil behavior, knowledge of which should benefit all areas of geotechnical engineering, including earthquake engineering. The unique features of Spacelab are the availability for sustained periods (several days) of high-vacuum and zero-gravity conditions.

The space vacuum should make possible the rapid removal of gases from large samples and the study of the mechanical behavior of soils in the absence of pore pressures. If ultrahigh-vacuum test capability is developed for Spacelab, studies of surface adsorption phenomena and their influences on interparticle friction, swelling, time-dependent deformation phenomena, adsorbed

---

\*Subcommittee Chairman - J. Mitchell; Secretary - G. Castro

water structure, ion-exchange behavior, fluid flow, and diffusion could be conceived.

The immediate use of Spacelab for geotechnical research, however, relates to the sustained zero-gravity environment. Heretofore, the only zero-gravity testing opportunities were in the MSFC and other NASA drop-tower facilities and in parabolic flight trajectories of aircraft and rockets, neither of which offers adequate time for sample preparation and testing.

Zero-gravity studies assume special importance in soils as opposed to other engineering materials because of the strong gravity dependence of all aspects of their mechanical behavior. This dependence is due to the fact that the mechanical properties of soils are determined mainly by interparticle friction, whereas the properties of other engineering materials are almost purely cohesive and are therefore essentially gravity independent.

Typical phenomena and properties, the understanding of which will benefit from experimentation under zero-gravity conditions, are:

- Stress-strain and strength under low confinement
- True cohesion in fine-grained soils
- Tensile strength of fine-grained soils
- Colloidal phenomena in fine-grained soils (e.g., flocculation-deflocculation, soil-structure formation, and osmotic and diffusion flow)
- Capillary phenomena

In addition, most mathematical models for deformation and failure of soil masses, such as bearing capacity, lateral pressure, slope stability, and stress distribution, contain gravity-dependent terms. Tests in Spacelab can be designed to verify these dependencies.

Furthermore, the zero-gravity environment will enable preparation of homogeneous, isotropic specimens and the application of uniform stress fields completely free of gravitational body forces.

Spacelab experiments on the above topics should initially be as simple as possible in terms of geometry, apparatus, and procedure. Insights derived from these experiments should have broad geotechnical applications, including the prediction of soil behavior during earthquakes. For example, the understanding of the behavior of granular materials under low effective confining stresses is crucial to a quantitative explanation of liquefaction and softening induced by earthquake loading.

Subsequent experiments of greater complexity may be warranted for the study of specific earthquake engineering problems.

## 6. Management, Operation, and Funding of NASA/MSFC for Earthquake Engineering Research

Various possible schemes for managing, operating, and funding earthquake research at MSFC were discussed at length during the workshop. Several important considerations surfaced during these discussions.

Many of the facilities reviewed during the site visit and workshop are now being used for full-scale static and dynamic testing of the Space Shuttle vehicle. If it is decided that upon completion of these test programs MSFC is to be used for earthquake engineering research, it is only logical that the experienced NASA/MSFC personnel currently operating the various test facilities should be fully utilized in the management and implementation of such research. For this reason, the consensus of the workshop participants was that both management and operation of the MSFC test facilities for earthquake engineering research should be a NASA function.

Funding is a more complex matter. Currently the NSF and the USGS have the responsibility for administering the funds specifically designated for the national earthquake hazards reduction program. Other governmental agencies, such as the Department of Housing and Urban Development, NASA, the National Bureau of Standards, the Nuclear Regulatory Commission, the Department of Defense, and the Veterans Administration, each have earthquake hazard mitigation needs and therefore are likely to be users of a large-scale test facility. At present, however, the level of funding provided for the national earthquake hazards reduction program is hardly sufficient to perform the necessary theoretical and small-scale testing work needed to effectively fulfill the research needs implicit in the *Earthquake Hazards Reduction Act of 1977*. Some of the funding for the current program could be diverted to cover the costs required for developing specific test requirements and conducting cost-evaluation studies of large-scale testing, but it would not be sufficient to cover the cost of operating the MSFC facilities.

Because some of the NASA/MSFC test facilities considered in this workshop have been designated as NASA-dedicated test facilities, it is conceivable

that the cost of building maintenance and operation of such facilities would not be charged to earthquake engineering research programs. Similarly, it is conceivable that some of the special test equipment for earthquake engineering research could be used by other ongoing NASA programs and the cost of such equipment could be prorated, on a cost-sharing basis, with those NASA programs.

A funding plan option that could be practicable involves establishment of interagency cooperative testing programs. Under this plan, NASA or the NSF would fund the management, operation, and any necessary modification of the MSFC large-scale test facilities. Thus, the cost of scientific project activities, including research by the principal investigator and necessary earthquake engineering support, test specimen, and special test fixtures would be funded by the using agency.

In summary, NASA/MSFC would manage and operate the test facilities, but earthquake engineering researchers would be responsible for test program planning, the conduct of research, and the interpretation of results. A funding plan cannot be recommended until costs for conducting large-scale testing at MSFC have been established.

## 7. Conclusions and Recommendations

### CONCLUSIONS

From the results of the workshop, the following conclusions may be drawn:

- The NASA/MSFC test facilities and supporting capabilities can be productively utilized in earthquake engineering research
  - A wide spectrum of both structural and geotechnical research programs could be implemented utilizing the unique large-scale ground-based test facilities at MSFC.
  - Spacelab offers unique opportunities for conducting basic research on soil behavior that would have a broad range of geotechnical engineering applications, including geotechnical earthquake engineering.
- The ground-based test facilities at NASA/MSFC should be considered mainly for large-scale testing because adequate test facilities for performing smaller scale tests currently exist in the United States.
- The unique NASA/MSFC test facilities and supporting capabilities could be used by individual Principal Investigators or by investigator teams from academic institutions and other organizations for conducting earthquake engineering research that cannot be performed elsewhere in the United States, thereby enhancing significantly the objectives of the *Earthquake Hazards Reduction Act of 1977*.
- Important earthquake engineering research could be conducted at NASA/MSFC without any modifications or with only minimal modifications or additions to existing facilities or equipment. More extensive facility or equipment modifications could introduce an entirely new dimension in earthquake engineering research that, to date, has been unfeasible and cost-prohibitive.
- Although no cost analyses were performed during the workshop, it appears that it would be cost-prohibitive to duplicate elsewhere the current NASA/MSFC capabilities and their potential for earthquake engineering research, even if extensive modifica-

tions were to be made to the existing facilities and/or equipment at NASA/MSFC to accommodate a long-range, complex, large-scale test program. This assessment is based on the following considerations: the large size, capacity, and versatility of the existing MSFC facilities, the testing equipment, and the automatic load control and data acquisition systems; the long-standing and proven technical expertise of MSFC personnel for operating large-scale dynamic test facilities; the extensive MSFC experience and current capabilities for executing complex and multidisciplinary research programs in close coordination with individual Principal Investigators or multinational research teams.

- Final conclusions regarding a long-range earthquake engineering research program using the NASA/MSFC facilities and supporting capabilities should await the results of comprehensive cost analyses that are based on specific test requirements developed in sufficient detail for such a potential program.

#### RECOMMENDATIONS

On the basis of the technical evaluation reported herein, the following recommendations are made relative to follow-up activities.

- A structural engineering task committee and a geotechnical engineering task committee should be established to accomplish the following tasks:
  - Develop short- and long-range objectives and technical rationale for a large-scale test program in earthquake engineering research that would utilize the NASA/MSFC facilities and supporting capabilities and involve Principal Investigators from the academic community, industry, and other research organizations from the private sector.
  - Develop minimum test requirements for individual research programs identified in the workshop that could be performed at NASA/MSFC with little or no modifications or additions to the existing facilities and equipment. The test requirements should be in sufficient detail to allow realistic cost analyses to be made for each program.
  - Develop test requirements for research programs identified in the workshop that would require more extensive modifications to the existing facilities. These test requirements should also



be in sufficient detail to allow realistic cost analyses to be made for these research programs.

- On the basis of earthquake engineering research needs alone, establish priorities and sequence of research programs or tasks that could not be implemented without the utilization of the NASA/MSFC facilities and supporting capabilities. Such sequence could conceivably include a combination of projects requiring little or no modifications to the existing facilities and projects requiring moderate or extensive facility modifications.

In performing these tasks, consideration should be given to testing needs for evaluating current construction techniques for all types of man-made works; to geotechnical testing needs for natural and man-made soil deposits and earth structures, as well as for soil-structure interaction; and to testing needs for repair and strengthening of existing structures typical of United States construction.

- Detailed cost analyses should be performed on the programs and test sequences identified by the structural and geotechnical engineering task committees. Such analyses should be performed by independent, expert, professional organizations.
- If the results of the cost analyses indicate that a large-scale test program utilizing the NASA/MSFC facilities is technically and operationally feasible and can be cost-effective, as well as fiscally viable, and funded without compromising other necessary research programs, such a program should be implemented at the earliest possible time.
- Although Spacelab was identified as a unique test facility for performing basic geotechnical research, the complete spectrum of its capabilities for such potential research has not as yet been fully assessed. Accordingly:
  - A forum should be established through which the potential utilization of Spacelab in basic geotechnical research, as well as the impact of such research on earthquake engineering problems, could be fully assessed. Individual geotechnical researchers should be made aware of these new experimental research possibilities.
  - Flight opportunities for Spacelab experiments on soil behavior should become available to geotechnical researchers, following similar evaluation procedures established for experiments associated with other scientific disciplines.



## References

1. *Application of Space Technology to Crustal Dynamics and Earthquake Research*, draft report, Office of Space and Terrestrial Applications, National Aeronautics and Space Administration, Washington, D.C., August 1978.
2. *Proceedings of a Workshop on Earthquake-Resistant Reinforced Concrete Building Construction*, University of California, Berkeley, July 1977.
3. *Earthquake Environment Simulation - Final Report and Proceedings of a Workshop on Simulation of Earthquake Effects on Structures*, San Francisco, September 1973, Academy of Engineering, Washington, D.C., 1974.
4. *Earthquake-Resistant Masonry Construction: National Workshop*, edited by R. A. Crist and L. E. Cattaneo, Center for Building Technology, Institute for Applied Technology, National Bureau of Standards, Washington, D.C., September 1976.
5. *Earthquake Prediction and Hazard Mitigation Options for USGS and NSF Programs*, National Science Foundation and U.S. Department of the Interior, Washington, D.C., September 1976.
6. *Research Needs and Priorities for Geotechnical Earthquake Engineering Applications*, edited by K. L. Lee, W. F. Marcuson III, K. H. Stokoe, Jr., and F. Y. Yokel, University of Texas, Austin, June 1978.
7. Hanson, R. D., *Repair, Strengthening and Rehabilitation of Buildings - Recommendations for Needed Research*, No. UMEE-77R4, Department of Civil Engineering, University of Michigan, Ann Arbor, October 1977.

8. Bertero, V. V., R. W. Clough, and M. Oliva, "Use of Earthquake Simulators and Large-Scale Loading Facilities in ERCBC," *Proceedings of a Workshop on Earthquake-Resistant Reinforced Concrete Building Construction*, University of California, Berkeley, July 1977.
9. Oesterle, R. G., et al., *Earthquake Resistant Structural Walls - Tests of Isolated Walls*, PCA R/D Ser. 1571, Research and Development Construction Technology Laboratories, Portland Cement Association, Skokie, Illinois, November 1976.
10. Bertero, V. V., *Identification of Research Needs for Improving Aseismic Design of Building Structures*, Report No. EERC 75-27, Earthquake Engineering Research Center, University of California, Berkeley, 1975.
11. URS/John A. Blume & Associates, Engineers, Job File No. 7904, personal communication, from R. D. Hanson, Civil Engineering Division, University of Michigan, Ann Arbor, to R. E. Scholl, URS/John A. Blume & Associates, Engineers, San Francisco, March 1979.
12. Silver, M. L., *Review of Cyclic Triaxial Testing Procedures and Shaking Table Test Facilities in Japan*, Department of Materials Engineering, University of Illinois, Chicago, December 1975.
13. Hudson, H. E., "Dynamic Tests of Full-Scale Structures," *Earthquake Engineering*, edited by R. L. Wiegel, Prentice-Hall, New Jersey, 1970.
14. Shepherd, R., and P. C. Jennings, "Experimental Investigation: Correlation with Analysis," *Proceedings of a Workshop on Earthquake-Resistant Reinforced Concrete Building Construction*, University of California, Berkeley, July 1977.
15. Chen, C. K., R. M. Czarnecki, and R. E. Scholl, "Destructive Vibration Test of a 4-Story Concrete Structure," Paper No. SP-55-24, *Douglas McHenry International Symposium on Concrete and Concrete Structures*, Publication No. SP-55, American Concrete Institute, Detroit, 1978.

16. Galambos, T. V., and R. L. Mayes, *Dynamic Tests of a Reinforced Concrete Building*, Research Report No. 51, School of Engineering and Applied Science, Department of Civil Engineering, Structural Division, Washington University, St. Louis, June 1978.
17. Kuznetsov, G. V., and V. P. Ulybin, *Change in the Magnitude of the Seismic Effect of Quarry Blasts as a Function of Various Factors*, translated from the Russian, No. FTD-HC-23-1569-74, Foreign Technology Division, 1974.
18. Higgins, C. J., and G. E. Triandafilidis, "The Simulation of Earthquake Ground Motions with High Explosives," *Proceedings, Sixth World Conference on Earthquake Engineering*, New Delhi, January 1977.
19. Rojahn, C., and S. H. Negmatollaev, "Forced Vibration Tests of a Three-Story Reinforced Concrete Frame and Shear-Wall Building in Tadzhiz S.S.R.," *Proceedings of the American Society of Civil Engineers Engineering Mechanics Division Specialty Conference on Dynamic Response of Structures*, University of California, Los Angeles, 1976.
20. Mills, P. H., "Blast Dynamics of a Model Structure," Master's thesis, School of Engineering and Applied Science, University of California, Los Angeles, 1972.
21. Applied Nucleonics Company, Inc., *Seismic Proof Tests Using Strong Ground Motion Produced by Explosions*, Report No. 1060-5, Los Angeles, August 1973.
22. "Simulation of Strong Earthquake Motion with Contained Explosion Line Source Arrays," Stanford Research Institute, Palo Alto, interim report, March 1979 (to be published).
23. Anderson, D. G., "Dynamic Modulus of Cohesive Soils," Ph.D. dissertation, No. UMEE-74RZ, Department of Civil Engineering, University of Michigan, Ann Arbor, June 1974.

24. McLamore, V. R., D. G. Anderson, and C. Espana, "Crosshole Testing Using Explosives and Mechanical Energy Sources," *Dynamic Geotechnical Testing*, special publication STP654, American Society for Testing and Materials, Baltimore, 1978.
25. Woods, R. D., "Measurement of Dynamic Soil Properties," *Proceedings of the American Society of Civil Engineers Geotechnical Engineering Division Specialty Conference on Earthquake Engineering and Soil Dynamics*, Pasadena, June 1978.
26. Silver, M. L., *Laboratory Triaxial Testing Procedure to Determine the Cyclic Strength of Soil*, Report No. NUREG 0031, Division of Reactor Safety Research, Office of Nuclear Regulatory Research, U.S. Nuclear Regulatory Commission, Washington, D.C., June 1977.
27. Pokrovsky, G., and I. Fyodorov, *Centrifugal Testing in the Construction Industry*, draft translation, U.K. Building Research Establishment, Vol. I and II, 1975.
28. Arulanandan, K., "Need for Research and Development of Large-Capacity Shakers for Dynamic Centrifuge Modeling," Department of Civil Engineering, University of California, Davis (in preparation).
29. *U.C. Davis-ARC-NSF Geotechnical Centrifuge: Centrifuge Facility for Research in Geotechnical Engineering*, Department of Civil Engineering, University of California, Davis, January 1979.
30. "Invention Can Help Engineers Determine Reaction of Some Soils During Quakes," *University Bulletin* (publication for faculty and staff), Vol. 26, No. 12, University of California, Berkeley, January 9, 1978.
31. URS/John A. Blume & Associates, Engineers, *Research Proposal for Development of Field Techniques to Measure Damping Values for Near-Surface Rocks and Soils*, program solicitation NSF 78-22, Earthquake Hazards Mitigation, San Francisco, September 1978.

32. Fry, Z. B., *Report 1: Development and Evaluation of Soil Bearing Capacity; Foundations of Structures, Field Vibratory Test Data*, Technical Report No. 3-632, U.S. Army Engineer Waterways Experiment Station, Vicksburg, Mississippi, 1963.
33. Richart, F. E., and R. V. Whitman, "Comparison of Footing Vibration Tests with Theory," *Journal of the Soil Mechanics and Foundations Division*, American Society of Civil Engineers, Vol. 93, No. SM6, 1967.
34. Wong, H. L., J. E. Luco, and M. D. Trifunac, "Contact Stresses and Ground Motion Generated by Soil-Structure Interaction," *Michigan International Journal of Earthquake Engineering and Structural Dynamics*, Vol. 5, Ann Arbor, 1977.
35. URS/John A. Blume & Associates, Engineers, "Applications in Soil-Structure Interaction," San Francisco (in preparation).
36. URS/John A. Blume & Associates, Engineers, Job File No. 7904, personal communication, from P. Hadala, Head, Earthquake Engineering Division, Geotechnical Laboratories, U.S. Army Engineer Waterways Experiment Station, Vicksburg, Mississippi, to T. A. Moore, URS/John A. Blume & Associates, Engineers, San Francisco, April 4, 1977.
37. "A Proposal for U.S. Participation in U.S.-Japan Cooperative Research Program Utilizing Large-Scale Testing Facilities," Earthquake Engineering Research Center, University of California, Berkeley (in preparation).
38. Silver, M. L., M. M. Baligh, G. Castro, W. F. Marcuson III, J. K. Mitchell, and S. Sture, *The Potential for In-Space Research on Soil Behavior -- An Overview Study*, final report, Contract No. NAS8-32993, University of Illinois, Chicago, 1979.
39. DeSanctis, C. E., *Space Transportation System/Spacelab Accommodations*, No. 78-179, American Institute of Aeronautics and Astronautics, 16th Aerospace Sciences Meeting, Huntsville, Alabama, January 16-18, 1978.

40. Okada, T., and M. Seki, "A Simulation of Earthquake Response of Reinforced Concrete Buildings," *Proceedings, Sixth World Conference on Earthquake Engineering*, Vol. 9, New Delhi, January 1977.
41. Arnold, C., J. A. Blume, A. G. Brady, J. D. Cooper, B. R. Ellingwood, H. H. Fowler, D. K. Keeker, C. M. Wentworth, and P. I. Yanev, contributing authors, *Reconnaissance Report: Miyagi-ken-oki Earthquake, Japan, June 12, 1978*, edited by P. I. Yanev, Earthquake Engineering Research Institute, Berkeley, December 1978.
42. Steinbrugge, K. V., "Earthquake Damage and Structural Performance in the United States," *Earthquake Engineering*, edited by R. L. Wiegel, Prentice-Hall, New Jersey, 1970.
43. URS/John A. Blume & Associates, Engineers, *Influence of Nonstructural Partitions on the Dynamic Response Characteristics of Structures*, Report No. JAB-99-94, San Francisco, July 1972.
44. *Dynamic Geotechnical Testing*, symposium sponsored by American Society for Testing and Materials, Committee D-18 on Soil and Rock for Engineering Purposes, Denver, June 28, 1977, special publication STP 654, American Society for Testing and Materials, Baltimore, 1978.
45. Casagrande, D. R., *Dynamic Soils Investigation for Ground Radius Effects Study - Redstone Arsenal, Alabama*, miscellaneous paper No. 4-910, U.S. Army Engineer Waterways Experiment Station, Vicksburg, Mississippi, July 1967.



## **APPENDIX A**

### **Roster of Workshop Participants**

## **Roster of Workshop Participants**

Persons involved in the evaluation of the NASA/MSFC facilities are listed in the following pages; they have been grouped into two categories: (1) Workshop Participants and (2) Government Agency Representative Workshop Participants. In addition, several NASA/MSFC persons were available throughout the duration of the workshop to describe and respond to questions regarding the MSFC facilities; these persons are listed as NASA/MSFC Representatives at Workshop.

## WORKSHOP PARTICIPANTS

Dr. John A. Blume, Workshop Chairman  
URS/John A. Blume & Associates,  
Engineers  
130 Jessie Street  
San Francisco, CA 94105  
415/397-2525

Dr. Roger E. Scholl, Workshop  
Secretary  
URS/John A. Blume & Associates,  
Engineers  
130 Jessie Street  
San Francisco, CA 94105  
415/397-2525

\* \* \* \* \*

Dr. Mihran S. Agbabian, President  
Agbabian Associates  
250 North Nash Street  
El Segundo, CA 90245  
213/640-0576

Dr. William G. Corley, Director  
Engineering Development Department  
Portland Cement Association  
5420 Old Orchard Road  
Skokie, IL 60076  
312/966-6200

Professor Vitelmo V. Bertero  
Department of Civil Engineering  
783 Davis Hall  
University of California  
Berkeley, CA 94720  
415/642-3655

Professor Ricardo Dobry  
Civil Engineering Department  
Rensselaer Polytechnic Institute  
Troy, NY 12181  
518/270-6360

Dr. Gonzalo Castro, Principal  
Geotechnical Engineers, Inc.  
1017 Main Street  
Winchester, MA 01890  
617/729-1625

Professor J. E. Fitzgerald, Chairman  
Civil Engineering Department  
Georgia Institute of Technology  
Atlanta, GA 30332  
404/894-2201

Dr. John T. Christian  
Consulting Engineer  
Stone & Webster Engineering Corp.  
245 Summer Street  
Boston, MA 02107  
617/973-2060

Professor Robert D. Hanson, Chairman  
Department of Civil Engineering  
University of Michigan  
Ann Arbor, MI 48109  
313/764-8494

Professor Ray W. Clough  
Department of Civil Engineering  
775 Davis Hall  
University of California  
Berkeley, CA 94720  
415/642-2618

Professor Wilfred D. Iwan  
Department of Applied Mechanics  
California Institute of Technology  
Pasadena, CA 91109  
213/795-6811 X1144

Professor Wayne Clough  
Department of Geotechnical  
Engineering  
Stanford University  
Stanford, CA 94305  
415/497-4164

Professor James K. Mitchell, Chairman  
Department of Civil Engineering  
439 Davis Hall  
University of California  
Berkeley, CA 94720  
415/642-1262

WORKSHOP PARTICIPANTS, Continued

Professor F. E. Richart, Jr.  
Civil Engineering Department  
2320 G.G. Brown Lab.  
University of Michigan  
Ann Arbor, MI 48109  
313/763-2146

Professor Jose M. Roesset  
Department of Civil Engineering  
University of Texas  
Austin, TX 78712  
512/256-8196

Professor Dwight A. Sangrey  
Department of Civil & Environmental  
Engineering  
Cornell University  
Ithaca, NY 14853  
607/256-3506

Professor Marshall L. Silver  
Department of Materials Engineering  
University of Illinois  
Chicago Circle Campus  
Chicago, IL 60680  
312/996-5165

Professor Mete A. Sozen  
Department of Civil Engineering  
Room 3112, Civil Engineering Bldg.  
University of Illinois  
Urbana, IL 61801  
217/333-3929

Professor Richard D. Woods  
Civil Engineering Department  
2322 G.G. Brown Lab.  
University of Michigan  
Ann Arbor, MI 48109  
313/769-4352

GOVERNMENT AGENCY REPRESENTATIVE WORKSHOP PARTICIPANTS

Dr. John B. Scalzi  
National Science Foundation,  
Workshop Sponsoring Agency  
1800 G Street, N.W., Room 1130  
Washington, D.C. 20550  
202/632-0648

Mr. Thomas L. Fischetti, Chief  
Geodynamics Branch  
NASA/Office of Space and Terrestrial  
Applications  
600 Independence Avenue, S.W.  
Washington, D.C. 20546  
202/755-3848

Dr. James F. Costello  
Structural Engineer  
U.S. Nuclear Regulatory Commission  
Washington, D.C. 20555  
301/427-4445

Mr. Andrei Gerich  
Structural Engineer  
U.S. Department of Housing  
and Urban Development  
451 7th Street, S.W., Room 6172  
Washington, D.C. 20411  
202/755-5924

Mr. James R. Harris  
Research Structural Engineer  
Center for Building Technology  
National Bureau of Standards  
Washington, D.C. 20234  
301/921-2170

Mr. James D. Pendergast  
U.S. Army Corps of Engineers  
Construction Engineering  
Research Laboratory  
P.O. Box 4005  
Champaign, IL 61820  
217/352-6511

NASA/MSFC REPRESENTATIVES AT WORKSHOP

NASA/MSFC Coordinating Committee:

Dr. George F. McDonough  
Deputy Associate Director for  
Engineering  
MSFC/EE01  
Marshall Space Flight Center,  
Alabama 35812  
205/453-4214

Dr. Nicholas C. Costes  
Senior Staff Scientist  
Space Sciences Laboratory  
MSFC/ES81  
Marshall Space Flight Center,  
Alabama 35812  
205/453-0946

Mr. Robert S. Garrett  
Office of Associate Director for  
Engineering  
MSFC/EE01  
Marshall Space Flight Center,  
Alabama 35812  
205/453-4215

Other NASA/MSFC Representatives at Workshop:

Dr. Ilmars Dalins  
MSFC/ES71  
205/453-3092

Mr. Richard L. Klan  
MSFC/PP03  
205/453-1034

Dr. Mathias P. Siebel  
MSFC/ES01  
205/453-3031

Mr. Carmine E. De Sanctis  
MSFC/NA01  
205/453-4610

Mr. Joseph T. Lundy  
MSFC/ET13  
205/453-4381

Mr. James M. Sisson  
MSFC/ES01  
205/453-3032

Mr. George J. Detko  
MSFC/ED21  
205/453-2476

Mr. Jack S. Moore  
MSFC/EP42  
205/453-3964

Mr. James B. Sterett  
MSFC/ET01  
205/453-3502

Mr. Erich E. Engler  
MSFC/EP13  
205/453-3958

Mr. Saverio F. Morea  
MSFC/EP01  
205/453-3908

Mr. Rodney D. Stewart  
MSFC/EL02  
205/453-3106

Mr. Paul W. Frederick  
MSFC/EP42  
205/453-4472

Mr. Milton A. Page  
MSFC/PS06  
205/453-3424

Mr. Richard E. Valentine  
MSFC/JA61  
205/453-3423

Mr. Billy J. Hawkins  
MSFC/EL02  
205/453-3109

Mr. George E. Shofner, Jr.  
MSFC/AB44  
205/453-2763

Mr. Gerald B. Waggoner  
MSFC/ET14  
205/453-4381

Mr. Garland D. Johnston  
MSFC/ET19  
205-453-1320

Mr. Charles E. Watson  
MSFC/ET02  
205/453-1627

## **APPENDIX B**

### **Workshop Agenda**

# Workshop Agenda

THURSDAY, FEBRUARY 22

<u>MORNING:</u>	General Session (MSFC Building 4200 - 10th Floor Conference Room P110)	
8:30-9:00	Registration and Badging	
9:00-9:05	Welcome	MSFC
9:05-9:10	Workshop Objectives - Introduction of Workshop Chairman	NSF (Dr. Scalzi)
9:10-9:15	Review of Workshop Agenda by Workshop Chairman	EERI (Dr. Blume)
9:15-9:40	Overview of MSFC Test Facilities and Spacelab Capabilities	MSFC
9:40-12:30	Tour of MSFC Test Facilities (including Space Shuttle) and Spacelab Mock-up	MSFC
<u>LUNCH:</u>	MSFC Building 4200 - Cafeteria	
<u>AFTERNOON:</u>	General Session (MSFC Building 4200 - Room P110)	EERI (Dr. Blume)
1:30-1:45	Scope of U.S. - Japan Agreement on Joint Earthquake Research	EERI (Dr. Hanson)
1:45-3:30	10-Minute Prepared Presentations by Other Government Agencies on Possible Use of MSFC Facilities or Use of Data Derived from Tests on Facilities	Govt. Agency Representatives
3:30-4:00	Facility Management and Resources Assumptions - Requirements for Joint-Agency Project Planning	MSFC
4:00-5:30	Assignment of Participants to Workshop Panels; Assignment of Workshop Panel Chairmen and Secretaries	EERI (Dr. Blume)
	Outline of Topics and Specific Questions to be Considered by Experts During Panel Discussions	EERI (Dr. Blume)
	Outline of Report by EERI on Workshop Proceedings	EERI (Dr. Scholl)
	General Discussion, Chaired by EERI (Dr. Blume)	Participants
5:30	Visit to Alabama Space and Rocket Center; Social Hour; Refreshments and Barbecue Dinner	MSFC



FRIDAY, FEBRUARY 23

MORNING:

8:30-12:00 Workshop Panel Meetings in Separate Rooms Panel Chairmen

LUNCH: MSFC Building 4200 - Cafeteria

AFTERNOON:

1:00-4:00 Workshop Panels Continue to Meet and Prepare Preliminary Reports in Written Form, Suitable for Typing Panel Chairmen

4:00-5:30 General Session (MSFC Building 4200 - Room P110) EERI

- 15-Minute Presentations by Panel Chairmen on Individual Panel Findings Panel Chairmen

- General Discussion EERI

SATURDAY, FEBRUARY 24

MORNING:

8:30-10:30 Workshop Panels Meet Individually to Review and Finalize Their Portion of Their Report, Suitable for Typing Panel Chairmen

10:30-12:30 General Session (MSFC Building 4200 - Room P110) EERI

- Presentations by Panel Chairmen on Individual Panel Findings - Emphasis Given to Additions or Modifications on Panel Minutes Since Earlier Discussions During Plenary Session of Previous Day

- Specific Recommendations for Joint-Agency Project Planning

- Recommendations for Follow-On Activities

- Workshop is Adjourned

LUNCH: MSFC Will Provide Transportation to and from Restaurant

2:00-4:00 Executive Session MSFC/NSF/EERI and Other Visitors If Available

## **APPENDIX C**

### **Research Needs in Earthquake Engineering**

## Research Needs in Earthquake Engineering

The objective of most research in earthquake engineering is to develop methods of design and economic construction that produce functional seismic-resistant structures.

Current seismic-resistant structural design practice relies heavily on concepts of structural performance that have evolved from post-earthquake damage inspections and small-scale shaking table tests. As beneficial as these concepts are, there are many factors that cannot be evaluated by damage inspection or small-scale tests.

Following the 1968 Tokachi-oki earthquake in Japan and the 1971 San Fernando earthquake in California, during which numerous reinforced concrete buildings of modern design suffered severe damage, it became evident that greater effort should be made to test full-scale structures to determine parameters that cannot be evaluated otherwise. These tests should simulate earthquake loading conditions and should be used to determine behavior characteristics of the structural system when loaded to ultimate capacity.

Earthquake engineering research needs that have been subsequently identified are examined in the following three sections. The first section surveys research needs in the field of earthquake engineering by summarizing recommendations reported in the proceedings of seven recent workshops convened to discuss research needs. The second section analyzes and assigns priority to these research needs. The third section draws conclusions on the action necessary to fulfill the research needs.

### SURVEY OF RESEARCH NEEDS: PUBLISHED RECOMMENDATIONS FOR RESEARCH

Over the past several years, a number of workshops have been convened to discuss research needs in earthquake engineering. This section itemizes the recommendations for research reported in the proceedings of seven workshops held during the period 1973 to 1978. These recommendations are important

because they represent the consensus of expert and experienced professionals in the field of earthquake engineering.

The published recommendations of each workshop are presented below. They are grouped according to their applicability to research involving either (1) structural systems or (2) geotechnical systems. Research having geotechnical applications includes studies of soil behavior and earth structures, soil-structure interaction, and in-space soil behavior.

Workshop: *Earthquake-Resistant Reinforced Concrete Building Construction*<sup>1</sup>

This workshop, held from July 11 to July 15, 1977, was organized by Professor V. V. Bertero of the University of California, Berkeley, and was sponsored by the National Science Foundation (Grant No. NSF/ENV76-01923). The following recommendations for earthquake engineering research were made.

Structural Systems:

- Engage in integrated analytical and experimental research on the three-dimensional linear elastic and hysteretic behavior of real buildings and their sub-assemblages under seismic loading conditions. Emphasis should be placed on comprehensive studies of:
    - the stress-strain relationship of different types of reinforced concrete materials, considering variation in combined multiaxial and shear stresses
    - bond-slip relationships
    - behavior of different types of foundations under seismic excitation and its effect on building response to determine guidelines for selecting and designing foundation systems
    - influence of different floor systems (including diaphragm deformability)
    - effect of joint flexibility, considering possible bond deterioration
    - column behavior under biaxial lateral forces and axial loads varying from tension to compression
    - effect of nonstructural components.
- Generic studies of connections, components, and sub-assemblages forming part of the primary seismic load-carrying system in prefabricated concrete buildings should be performed. Similar studies should be con-

ducted on prestressed concrete components and assemblies.

To carry out all of these studies, it will be necessary to develop several large-scale loading facilities (structural floor-wall reaction systems); make greater use of the few available small- and medium-size simulators; determine the need and feasibility of a large earthquake simulator capable of testing full-scale structures; and develop efficient computer-simulation techniques to model realistic structures and perform design-oriented parametric studies.

- Encourage researchers and professionals to:
  - evaluate current building code detailing requirements; establish criteria to indicate the appropriate method of design according to the expected nature of structural action
  - evaluate the cost-effectiveness of the added expense of providing earthquake resistance beyond that required for safety as compared with the cost of repairing infrequent damages
  - develop guidelines for seismic analysis and design that can be used by the design profession.

All these should be done considering different types of buildings in different seismic regions.

- Develop procedures to determine the seismic resistance and acceptable damage levels of existing buildings. Evaluation is needed of the materials and techniques presently used in repairing and retrofitting. Guides for their use should be prepared and new methods explored. Forced-vibration tests up to collapse are suggested for buildings scheduled to be demolished.

Geotechnical Systems: None.

A total of 114 recommendations dealing with a wide range of research and development needs were formulated during this workshop. Priorities were assigned to these recommendations by the working group that developed them.

After reviewing the final recommendations, the organizer, organizing secretary, and steering committee identified the above items as needs of the highest overall priority, or of common concern to several working groups.

Workshop: *Research Needs and Priorities for Geotechnical Earthquake Engineering Applications*<sup>2</sup>

This workshop was held on June 2 and 3, 1977, and was sponsored by the National Science Foundation and the National Bureau of Standards. The following recommendations for earthquake engineering research were made.

Structural Systems: None.

Geotechnical Systems:

- Evaluate, minimize, and understand the influence of sample disturbance on laboratory test results.
- Provide a better understanding of basic soil response. This is especially important because of the need to provide input and verification of improved constitutive relationships.
- Develop field techniques for evaluating liquefaction potential.
- Develop reliable in-situ stress-strain relationships.
- Measure directly or indirectly the in-situ static state of stress by improved techniques.
- Develop field methods to determine and predict settlement caused by dynamic loads.
- Develop multidimensional, nonlinear mathematical models of large deformation and failure of soil. Verification of these models should be accomplished through comparison with:
  - field observations and/or prototype experiments
  - bench-mark problems
  - experimental results.
- Increase efforts to collect instrumental data on damaging ground motion close to the causative fault, particularly for earthquakes of magnitude 7 or larger. The current lack of such data compromises the confidence of earthquake-resistant design and increases the construction costs of critical facilities.
- Provide a better understanding of the seismicity of the United States east of the Rocky Mountains where severe data limitations presently exist.
- Provide a better understanding of the physical phenomena and processes responsible for damaging ground motion and surface faulting.

- Devise new data acquisition and processing techniques and reevaluate existing data to assess and improve the reliability of ground motion predictions.
- Introduce new understanding of the nature of seismic loads to the design profession and incorporate it into improved design methods and design decision processes.
- Investigate and evaluate sites that have experienced strong shaking during earthquakes.
- Develop new methods of stability analysis, especially those that operate in the effective stress domain.
- Develop methods to evaluate the seismic stability of offshore soils.
- Develop fundamental models and methods to predict realistic stress-strain relationships.
- Perform instrumentation installation and subsurface investigations in areas believed to have great earthquake potential.
- Investigate and evaluate more case histories.
- Use explosives to develop transient loadings on prototypes or field models.
- Develop centrifuge facilities for testing models.
- Measure instrumented prototypes or field models that are excited by mechanical oscillators.
- Perform shake table tests.
- Make field observations of the spatial distribution of seismic motions.
- Perform analytical studies to predict the wave content of the free-field motions.
- Represent earthquake input as a random process.
- Consider probabilistic approaches to include the effect of uncertainties in the characteristics of the seismic motions and in the soil properties.
- Determine foundation stiffness for embedded three-dimensional foundations.
- Study the effect of the conditions of the backfill on the motion, stiffness, and dynamic earth pressures for embedded structures.
- Determine the effect of various types of waves on the motion at the foundation level, including both horizontal and rotational components.
- Evaluate the importance of the mat flexibility when dealing with surface waves or with large mats supporting several structures.

- Study the interaction between adjacent structures, considering various types of waves and the resulting earth pressures and including three-dimensional situations.
- Investigate the dynamic characteristics of a single pile as predicted by various models, including various types of waves and accounting for nonlinear soil behavior.
- Study the dynamic behavior of pile groups with the same considerations made above for a single pile.
- Determine the dynamic behavior of spread footings, starting first with simplified two-dimensional models that account for the distribution of vertical stress, continuing with three-dimensional models for a homogeneous soil, and considering finally a fully three-dimensional situation with nonhomogeneous soil properties.
- Study the actual distribution of earth pressures in the neighborhood of the foundation under the seismic excitation, considering nonlinear soil behavior with special emphasis on the case of adjacent structures.
- Develop fully three-dimensional solutions for buried structures, considering the effects of various assumptions on the spatial distribution of the seismic motions.
- Further refine the equivalent linear procedure (iterative solution) for two- or three-dimensional situations.
- Evaluate the approximate linear procedure and the equivalent linearization technique by comparing results with those from a true nonlinear analysis using an appropriate nonlinear soil model. Determine the range of validity of each method and derivation of practical, simplified rules to obtain effective soil properties for a simple linear analysis.
- Study other nonlinear problems such as separation of the mat or the sidewalls from the soil, considering nonlinear soil behavior and deriving simplified procedures to estimate the importance of these effects in typical cases.
- Conduct parametric studies with existing methods and typical structures to assess the effect of various assumptions on the structural response, to obtain a better understanding of the importance of various approximations, and to derive simplified procedures suitable for code-type design specifications.
- Improve distribution of strong-motion recording instruments in buildings and the adjacent free field in active seismic areas to determine six components



of motion at selected floor levels and measurements of motions and pressures in the soil.

- Perform low-amplitude forced-vibration tests of some existing buildings to verify present theories in the linear elastic range.
- Perform field tests of prototype systems.
- Study basic soil properties in new testing environments (e.g., weightlessness and ultrahigh vacuum of space), which will become available under laboratory-controlled conditions in the manned orbiting laboratory, Spacelab, currently planned for the 1980s.

Overview Study: *The Potential for In-Space Research on Soil Behavior*<sup>3</sup>

On the basis of the last recommendation, made at the *Research Needs and Priorities for Geotechnical Earthquake Engineering Applications*<sup>2</sup> workshop, a preliminary study,<sup>3</sup> sponsored by the National Aeronautics and Space Administration, Office of Aeronautics and Space Technology (OSTA), and conducted by a team of geotechnical engineering specialists, was recently undertaken to identify geotechnical research areas that could benefit from an in-space research program on soil behavior. Although the study has not yet been completed, recommendations for possible research include the following:

- Study the role of material homogeneity and isotropy (fabric, structure) in controlling soil behavior.
- Test large-size specimens in the absence of stress gradients induced by gravitational body forces acting in both the solid and the fluid phases of soil mass, and determine the role of stress and stress-path homogeneity in controlling soil behavior.
- Investigate:
  - solid-fluid and fluid-fluid interactions in the absence of a gravitational potential
  - state of stress in interstitial fluids at rest:
    - contributions from matrix or capillary potential, osmotic or solute potential, and potential due to external gas pressure (in a pressure membrane apparatus)
    - the role played by buoyancy-driven convection and particle sedimentation in a terrestrial environment.
- Examine the behavior of soils with very loose and metastable structures as related to liquefaction or "air lubrication" phenomena.

- Investigate the behavior of dry, moist, partially saturated, and saturated soils at very low effective confining pressures under quasi-static and dynamic loading conditions; include studies of:
  - constitutive relations
  - strength-failure envelope at or near the effective stress origin
    - "true" cohesion
    - apparent cohesion
    - particle interlocking
    - tensile strength
  - stress wave propagation.
- Investigate the behavior of dry, moist, partially saturated, and saturated soils under cyclic loading; include studies of:
  - volume change characteristics
  - build-up and dissipation of excess pore fluid pressures.
- Examine:
  - fluid flow through soils in the absence of a gravitational potential
  - direct- and coupled-flow phenomena
  - multiple-fluid (miscible, immiscible) flow phenomena:
    - frontal instabilities
    - hydrodynamic dispersion
    - role played by buoyancy-driven convection and particle sedimentation in a terrestrial environment.
- Study the behavior of dry clay suspensions and clay-water-electrolyte systems in the absence of particle sedimentation.
- Examine the variation of clay properties with time and the effect of physicochemical forces of interaction, decoupled from effect of gravitational body forces.
- Evaluate the effect of particle surface impurities on the adhesive-frictional characteristics of soils. Degassing problems encountered in soil tests performed in ordinary vacuum chambers of laboratories on earth could, in principle, be eliminated by exposing soil particle suspensions (in the near-zero-gravity environment) to the ultrahigh vacuum of space prior to specimen preparation and testing.

- Evaluate plasticity theories with respect to the behavior of "weightless" granular soils and investigate stability problems.
- Study the effect of gravitational force field strength (<1g, 1g, >1g) on soil behavior (use of centrifuge testing in a near-zero-gravity environment).

Some of these research areas include aspects of soil behavior that are not directly related to seismic loading. However, the behavior of a soil deposit during and following an earthquake event partly depends on the previous history of the soil mass. The history of the soil deposit may, in turn, include events other than seismic excitation that nevertheless are closely related to areas identified for in-space research. Accordingly, these other aspects of soil behavior could be considered to be, in a broad sense, within the realm of geotechnical earthquake engineering.

Workshop: *Repair, Strengthening, and Rehabilitation of Buildings - Recommendations for Needed Research*<sup>4</sup>

This workshop, held on July 9 and 10, 1977, at the Rodeway Inn, San Francisco, was directed by Professor R. D. Hanson of the University of Michigan, Ann Arbor, and was sponsored by the National Science Foundation. The following recommendations for earthquake engineering research were made.

Structural Systems:

- Evaluate the seismic resistance of existing lime-mortar brick buildings.
- Develop a guideline of practice for the evaluation of existing buildings. This guideline should present the current state of practice for the evaluation of building hazards, a recommended procedure for establishing the desired level of building performance, and evaluation of various rehabilitation materials and techniques appropriate for the desired performance.
- Develop a manual of practice for the use of various repair materials and techniques. This manual should provide the information necessary to specify and quantify that the rehabilitation will accomplish the planned objectives. This manual must be updated as experience and research data become available.

## Geotechnical Systems:

- Institute an expanded program of strong-motion instrumentation. Because observations of ground motion, foundation response, and earth pressures during future earthquakes are absolutely vital, this will make a significant contribution to the solution of problems in the geotechnical area. In addition to better instrumentation for ground motion determination in all areas of the country, such instrumentation must include:
  - "downhole" instrumentation to study site effects
  - arrays of instruments to record foundation motion simultaneously with that of the surrounding soils, including the free field
  - strain meters or other instrumentation to study the initiation of motion at the sourceand might include piezometers in connection with studies of liquefaction.
- Monitor the foundation performance of various types of buildings and the phenomena of soil-structure interaction and overturning during underground explosion tests.

## Workshop: North American Masonry Conference<sup>5</sup>

This workshop was held in August of 1978 at the University of Colorado, Boulder, and was partially sponsored by the National Science Foundation. The following recommendations for earthquake engineering research were made.

## Structural Systems:

- Establish whether:
  - member ductility demand can be calculated by elastic analysis techniques plus a judgment factor measuring the amount of ductility required
  - the inelastic theories that are available are sufficient for design use.
- Establish the failure modes of unreinforced and reinforced masonry construction.
- Conduct further tests to determine grout-block bond strength. Grout-block separation and face shell spallation are frequently observed in laboratory tests and in earthquake-damaged structures.

Geotechnical Systems: None.

Workshop: *Earthquake Environment Simulation*<sup>6</sup>

This workshop was held from September 7 to September 9, 1973, in San Francisco and was sponsored by the National Science Foundation. The following recommendations for earthquake engineering research were made.

Structural Systems:

- Conduct experimental studies, including static-cyclic motion and transient motion tests of subcomponents as well as of model and full-scale structures.  
It is believed a major portion of the knowledge required can be obtained from analysis and simple tests of elements, components, or fastening schemes. The entire building-equipment system must be evaluated in terms of strength, response, and failure modes.
- Measure gross material properties when subjected to various states of stress, strain, confinement, environment, aging, or joining. The goal is to obtain information concerning strength, ductility, hysteretic properties, prefailure and postfailure strength states, etc.
- Establish standards for proof loading of structural components.
- Determine methods of developing postfailure analyses for a particular design with the aim of devising lifesaving techniques.
- Develop repair and modification techniques to enhance strength and ductility of damaged buildings.
- Encourage research on innovative approaches to design and analysis.
- Develop effective educational programs to expedite changes in practice that accommodate improved design procedures to resist wind and seismic forces. The need is for education pertaining to primary and secondary structural-mechanical systems.
- Explore various types of loading devices and loading techniques for testing structural components and structures. These might include:
  - high-explosive charges
  - nuclear detonations

- programmed static-cyclic rams
- inertial shakers
- impact devices
- jacking tests in existing buildings or new construction.
- Consider phasing of input motions in connection with very long structures (e.g., bridges, pipelines, etc.), and develop methods of supplying such phasing of motions on simulators or shake tables.
- Perform shake table and/or nondestructive tests to verify the adequacy of analytical procedures and to measure physical parameters.
- Develop industrial standards for "labeling" or certifying the earthquake response capability of certain classes of industrial equipment (e.g., elevator equipment, hospital emergency-power generators, etc.). The following classes of equipment impose different testing requirements.
  - vital nuclear reactor equipment
  - critical hospital equipment
  - general plant equipment.
- Measure functional operation of equipment during earthquake testing. Higher ranges in frequency and higher acceleration levels may be required for testing equipment.

#### Geotechnical Systems:

- Conduct studies of:
  - site effects upon ground shaking
  - settlement (subsidence) and loss of bearing capacity
  - slope failures
  - design of direct and pile foundations (overturning)
  - earth pressures and retaining structures
  - soil and rock properties
  - foundation interaction.

Workshop: *Earthquake-Resistant Masonry Construction: National Workshop*<sup>7</sup>

This workshop was held on September 13 to 16, 1976, at the National Bureau of Standards, Boulder, Colorado, and was sponsored by the National Science

Foundation. The following recommendations for earthquake engineering research were made.

Structural Systems:

- Study the effect of cyclic loading and loading rate on strength and stiffness of masonry systems.
- Develop means for strength and stiffness evaluation of existing masonry structures.
- Examine the interaction of masonry in-fill panels with building frames when loaded by earthquake-induced forces.
- Evaluate bond between mortar grout and masonry units.
- Evaluate the nature of bond between reinforcement and anchorage to mortar and grout.
- Develop a three-dimensional mathematical model incorporating nonlinear (hysteretic) behavior of masonry structures using a deterministic approach.
- Develop a mathematical model for design optimization using a probabilistic approach based on experimental data.

Geotechnical Systems: None.

Workshop: *Earthquake Conference*<sup>8</sup>

This workshop was held on April 13 and 14, 1977, at the Berkeley Marina, in Berkeley, California, and was sponsored by the American Iron and Steel Institute. The following recommendations for earthquake engineering research were made.

Structural Systems:

- Study systems with eccentric bracing, giving consideration to development of the base anchorage.
- Develop a working document summarizing all types of bracing systems.
- Investigate dual systems, considering shear walls of concrete, precast concrete, and steel.
- Continue study of rigid frames, with emphasis on composite action.
- Study the ultimate capacity of tube systems.

- Investigate ultimate load of various types of energy-absorbing joints.
- Develop earthquake descriptors for use in design.

Geotechnical Systems: None.

## ANALYSIS OF RESEARCH NEEDS

The development of improved and economically feasible design and construction methods for building earthquake-resistant structures is dependent upon knowledge gained through experimental and analytical research. This section analyzes and gives priority to experimental and analytical research needs surveyed in the previous section.

### Experimental Research Needs

Of all the research needs described in the first section, the highest priority is given to the need for field measurements of ground motion and full-scale structural response during large earthquakes.<sup>1,2,4,6</sup> However, because large earthquakes occur infrequently, data collection is slow. To expedite the collection of data, the simulation of large seismic events is necessary.

There are four types of loading mentioned in the first section that can be used to simulate large earthquakes for testing purposes; these are underground explosions, shaking tables, vibration generators, and static-cyclic loading. A discussion of the applicability of each type of loading is presented below.

1. Underground Explosions - The creation of a national test site for the use of high explosives or nuclear detonations with specially constructed and properly instrumented facilities has been advocated by a number of earthquake engineers<sup>4</sup> as an effective way to produce a wave propagation environment with earthquake-like ground motion amplitudes and frequencies. However, it will be necessary to perform further studies of the techniques<sup>2</sup> for controlling the wave propagation environment prior to the initiation of a comprehensive research program.<sup>2,6</sup>

The explosive simulation technique is most applicable to experimental problems in which soil and soil-structure systems are important because these sys-



tems cannot be evaluated independently of the free-field medium.

2. Shaking Tables - Testing on medium-size or large-size shaking tables provides accurate reproduction of past earthquakes as many times as desired. For many of the problems of interest, these experiments are considered to be almost as informative as the observation of actual earthquakes.<sup>1,6</sup> A significant exception is the area of soils, rocks, and foundations, where shaking tables contribute little to the solution of some of the more important problems. Shaking tables are inadequate in this area; the different wave-phase relationships at the boundaries cannot be simulated because the often massive nature of these systems requires very small-scale modeling due to limits on shaking table size. When being used to perform tests of these systems, the shaking table must be rotated in a centrifuge to maintain the correct similitude relationship for the gravity-induced body forces.

Therefore, the most effective application of shaking tables is to obtain data on the nonlinear behavior and collapse mechanisms of full-scale structures subjected to simulated earthquakes.

3. Vibration Generators - The generation of dynamic structural response using a vibration generator with variable frequency harmonic excitation is useful for determining the dynamic response and acceptable damage levels of existing structures. Forced-vibration tests up to collapse have been suggested for structures scheduled to be demolished.<sup>1,4,7</sup> Such tests could also be used to determine the effect of soil-structure interaction on the large-amplitude vibration of buildings.<sup>2</sup>
4. Static-Cyclic Loading - Static-cyclic destructive loading tests of full-scale structures or subsystems can provide valuable information. Many of the most pressing questions related to material properties and certain aspects of structural behavior can be answered in this way.<sup>1,5,6</sup> The advantage of this procedure is that the test can be stopped at any time to observe damage sequence or to reestablish data observations.

Traditional methods of applying simulated earthquake loading to buildings and subsystems are not always useful for investigating some of the problems associated with soil systems. Conventional laboratory tests such as cyclic triaxial, simple shear tests, and resonant-column tests are often used to measure dynamic soil properties. However, the information from these tests

is not sufficient to provide a complete understanding of in-situ dynamic soil behavior. Therefore, it is essential that new methods of testing and measuring the dynamic behavior of soils, particularly at large strains, be developed.<sup>2,4,9</sup>

### Analytical Research Needs

It is necessary to develop analytical models to estimate the special characteristics of ground motion and the acceleration, velocity, and displacement time-histories of this motion for use as input motion in structural analysis and design. Such models must include the effects of the earthquake source, the transmission path, the amplification caused by local site conditions, and the influence of the presence of a structure on this motion (soil-structure interaction).

The development of analytical methods to characterize the earthquake response of structures and structural components, with an emphasis on their three-dimensional, nonlinear, and inelastic behavior when loaded to ultimate capacity, is also needed. These analytical procedures should be adapted for application to computer-aided structural design.

### Categorization of Experimental Research Needs

The published experimental research needs presented in the first section are categorized in Tables 1 and 2. Table 1 categorizes experimental research needs that involve structural systems and Table 2 categorizes experimental research needs that involve geotechnical systems. The categorization of research needs identifies the structural systems for which improved design and construction methods are sought and the type of load testing that is likely to provide the data necessary to make these improvements.

Both tables demonstrate that the highest priority is the need for destructive in-situ testing of total systems (rather than subsystems) by actual earthquakes, by underground explosions, or, to a lesser extent, by vibration generators. The need for destructive shaking table laboratory tests and static-cyclic loading tests of buildings, special structures, and subsystems is given high priority as well. In Table 2, the need for developing new methods of testing the dynamic properties of soils is illustrated. It

**TABLE 1**  
**EXPERIMENTAL RESEARCH NEEDS: STRUCTURAL SYSTEMS**

Research Subject	Priority	Type of Test*			Extent of System Modeled	
		In-Situ	Laboratory Model		Subsystem	Total
			Large	Small		
Very Massive Structures	High	1, 2, 4		3	no	yes
Very Massive Earth-Coupled Structures	High	1, 2, 4		3	no	yes
Very Long Structures (including bridges)	High	1, 2, 4	3, 4	3	no	yes
Complete Assemblies and Systems (may be in operational mode)	Medium	1, 2, 4			no	yes
Towers, Stacks, and Antennas	Medium	1, 2, 4	3, 5	3	no	yes
Bridges on Tall Piers	High	1, 2, 4		3	yes	yes
Retaining Walls, Quay Walls, etc.	High	1, 2, 4			no	yes
Offshore - Fixed	High	1, 2, 4	3, 5	3	yes	yes
Offshore - Floating (anchored)	Medium	1, 2, 4		3	no	yes
Offshore - Floating (free)	Medium	2, 4		3	no	yes
Underground and/or Buried Structures	High	1			yes	yes
Highly Variable, Nonengineered Structures	Medium		3		no	yes
Small Items (may be in operational mode)	Medium	2, 4	3		no	yes
Buildings	High	1, 2, 4	3, 5	3	yes	yes
Special Structures (e.g., nuclear containment vessels)	High	1, 2, 4	3, 5	3, 5	yes	yes

\*Numbers in these columns indicate the type of loading to be used:

- |                          |                        |
|--------------------------|------------------------|
| 1 future earthquakes     | 4 vibration generators |
| 2 underground explosions | 5 static-cyclic        |
| 3 shaking table          |                        |

TABLE 2

## EXPERIMENTAL RESEARCH NEEDS: GEOTECHNICAL SYSTEMS

Research Subject	Priority	Type of Test*			Extent of System Modeled	
		In-Situ	Laboratory Model		Subsystem	Total
			Large	Small		
Dynamic Properties of Soils	High	4, 5, †	3, 5, †, s	s	no	yes
Evaluation of Liquefaction Potential	High	1, 4, †	3, †, s	s	no	yes
Stress-Strain Relationships	High	1, 2, 5, †	3, 5, †, s	s	no	yes
Slope Failure	High	1, 2		6, s	no	yes
Site Effects	High	1, 2			no	yes
Subsidence, Settlement, Loss of Bearing Capacity	High	1, 2, †		3, 5, s	yes	yes
Foundation Overturning Effects for Design	High	1, 2		3, 6	no	yes
Dams and Reinforced Earth Structures	High	1, 2		3, 6	yes	yes
Effect of Embedment on Mat Foundations	High	1, 2, 4			no	yes
Interaction Between Adjacent Structures	High	1, 2, 4			yes	yes
Pile Foundations	High	1, 2, 4		3, 6	yes	yes
Spread Footings	High	1, 2, 4			no	yes
Buried Structures	Medium	1, 2			no	yes
Soil Behavior in Zero-Gravity Conditions	Medium			5, 6	yes	no

\*Numbers in these columns indicate the type of loading to be used:

- |                          |                        |
|--------------------------|------------------------|
| 1 future earthquakes     | 4 vibration generators |
| 2 underground explosions | 5 static-cyclic        |
| 3 shaking table          | 6 centrifuge           |

†Indicates that new testing methods are required.

§Indicates potential for in-space research.

is also evident from Table 2 that soil-structure interaction investigations will be field-test oriented.

Tables 3 and 4 identify critical parameters that govern system behavior during earthquake loading of structural systems and geotechnical systems, respectively, and that therefore require detailed study.

It is evident that sophisticated instrumentation and testing facilities are required to measure the variation of combined multiaxial and shear or flexural stress within structural systems during simulated earthquake loading. A further, and urgent, requirement is for improved methods of measuring in-situ dynamic soil properties such as settlement, stress-strain characteristics, shear wave velocity, and pore pressure at large strains.

#### ACTIONS NECESSARY TO FULFILL RESEARCH NEEDS

It is important to develop the following laboratory and field facilities for the purpose of (1) applying simulated earthquake loading to realistic models of soil and structural systems vulnerable to earthquake-induced damage and (2) monitoring the response of these models.

- A static-cyclic testing tower capable of applying a programmed horizontal load history in two directions with maximum forces sufficiently large to test full-scale buildings up to at least 10 stories in height to destruction.<sup>1,6,7,9</sup>
- A medium- or large-size shaking table with three or more directions of motion and a maximum stroke of  $\pm 600$  mm that can be used to analyze the destructive effects of contained liquids on dams, reservoirs, tanks, etc.<sup>9</sup>
- A large-size shaking table with two horizontal components of motion suitable for performing destructive tests of structures and components.<sup>1,6</sup>
- A large centrifuge with a lightweight shake table capable of testing 1/100-scale models of earth structures such as dams, embankments, and building sites in a simulated earthquake environment.<sup>2</sup>
- A site where high-explosives or nuclear devices could be detonated underground to produce a wave propagation environment with earthquake-like ground motion; could be used for full-scale testing of structures,

TABLE 3  
CRITICAL MODES OF LOAD TRANSFER: STRUCTURAL SYSTEMS

System	Component	Mode*
Reinforced and prestressed concrete structures	Columns	biaxial lateral forces with axial compression or tension
	Floors	diaphragm action
	Member joints	bond-slip, and combined multiaxial and shear stresses
	Prefabricated members	connections
	Shear walls	shear with axial compression or tension
	Beams	bending and shear
Timber structures	Nonstructural	base shear
	Beams, columns, diaphragms	connectors
Steel structures	Columns	biaxial lateral forces with axial compression
	Floors	diaphragm action
	Shear walls (dual systems with concrete)	shears with axial compression
	Systems with eccentric bracing	development of base anchorage
	Member joints	combined multiaxial and shear stresses
Masonry structures	Nonstructural	base shear
	Shear walls	diagonal tension-distribution of reinforcement required
		vertical shrinkage crack formation
		connection to roof and floor diaphragms
Spandrel beams	structural damping base anchorage coupling	

\*Investigate service load, strength, deformation, and ductility.

TABLE 4  
CRITICAL PARAMETERS: GEOTECHNICAL SYSTEMS

System	Item	Critical Parameters
Soils - wave propagating media	Nonload-bearing soils - unencumbered	ground motion near fault spatial distribution of ground motion amplification of ground motion caused by local site conditions pore pressure wave velocity
Earth structures	Load-bearing foundation soils, dams, and reinforced earth structures, embankments	pore pressure-liquefaction potential dynamic settlement volumetric strain (cohesionless soils) in-situ shear modulus Poisson ratio damping in-situ stress strain characteristics bearing capacity slope failure
Embedded structures	Pile foundation	distribution of vertical stress bearing capacity group effects (interference) lateral stiffness
	Mat and pile foundations, spread footings, buried structures, etc.	dynamic response as effected by embedment for various conditions of backfill earth pressure
Soil-structure interaction	Single ground-based structures	earth pressures modification of free-field ground motion
	Adjacent ground-based structures	earth pressures modification of free-field ground motion

soil-structure interaction, the dynamic characteristics of soils, and the effectiveness of recently developed geophysical instruments to measure these characteristics.<sup>2,4</sup>

- Improved instruments for determining the dynamic properties of soils, both in-situ and in laboratories.<sup>2,9</sup>
- Improved instrumentation of ground motion and response of existing structures, particularly those that are critical to life support or that contain hazardous materials, during future earthquakes.<sup>2,4,9</sup>
- Geotechnical research apparatus or facilities for Spacelab experiments to study the fundamental aspects of soil behavior in the unique and new testing environments of the weightlessness and high vacuum of space.<sup>2,3</sup>

It is also important to develop methods of simulating phasing of input motions in connection with very long structures such as bridges and pipelines with input from shaking tables or vibration exciters.<sup>6</sup> In addition, methods of assessing the hazard vulnerability of existing structures, including lime-mortar brick buildings, <sup>1,4,7,9</sup> are needed.



## APPENDIX C - REFERENCES

1. *Proceedings of a Workshop on Earthquake-Resistant Reinforced Concrete Building Construction*, University of California, Berkeley, July 1977.
2. *Research Needs and Priorities for Geotechnical Earthquake Engineering Applications*, edited by K. L. Lee, W. F. Marcuson III, K. H. Stokoe, Jr., and F. Y. Yokel, University of Texas, Austin, June 1977.
3. Silver, M. L., M. M. Baligh, G. Castro, W. F. Marcuson III, J. K. Mitchell, and S. Sture, *The Potential for In-Space Research on Soil Behavior -- An Overview Study*, final report, Contract No. NAS8-32993, University of Illinois, Chicago, 1979.
4. Hanson, R. D., *Repair, Strengthening and Rehabilitation of Buildings - Recommendations for Needed Research*, No. UMEE-77R4, Department of Civil Engineering, University of Michigan, Ann Arbor, October 1977.
5. *Proceedings of the North American Masonry Conference*, edited by J. L. Noland and J. E. Amrhein, University of Colorado, Boulder, August 1978.
6. *Earthquake Environment Simulation - Final Report and Proceedings on Simulation of Earthquake Effects on Structures*, San Francisco, September 1973, published by National Academy of Engineering, Washington, D.C., 1974.
7. *Earthquake-Resistant Masonry Construction: National Workshop*, edited by R. A. Crist and L. E. Cattaneo, Center for Building Technology, Institute for Applied Technology, National Bureau of Standards, Washington, D.C., September 1976.
8. *Earthquake Conference - Proceedings*, Berkeley Marina, Berkeley, April 1977.
9. *Earthquake Prediction and Hazard Mitigation Options for USGS and NSF Programs*, National Science Foundation and Department of the Interior, Washington, D.C., September 1976.

## **APPENDIX D**

### **Large-Scale Earthquake Engineering Test Facilities in the United States and Abroad**

## Large-Scale Earthquake Engineering Test Facilities in the United States and Abroad

This appendix describes the current capabilities of the various facilities used for performing large-scale testing in structural and geotechnical research in the United States and abroad. Five methods of testing are discussed:

- Static-cyclic (pseudodynamic) testing
- Shaking table testing
- Vibration generator testing
- Underground explosion testing
- Soil dynamics testing

### STATIC-CYCLIC (PSEUDODYNAMIC) TESTING

In static-cyclic testing, a structural element, or the structure itself, is subjected to prescribed oscillatory displacements at a relatively slow rate of loading. The advantage of this procedure is that the test can be stopped at any time to observe the damage sequence or to reestablish data observations. In this way, a better understanding of the mechanisms that produce stiffness and strength deterioration and those that cause failure of the structure can be determined. When static-cyclic testing methods are applied to reinforced concrete structures, however, the strain rate may have a significant effect on bond deterioration and on the behavior of anchorage and splicing of the main reinforcement.<sup>1</sup>

Cyclic loading facilities have been used for destructive testing of masonry walls and large specimens of steel frames, reinforced concrete frames, and shear walls at many research institutions, notably those in Japan, the United States, and New Zealand. However, apart from a few exceptions, until now it has been infeasible to test large structural systems -- those above 30 m in height and 1,000 tons in weight -- because a sufficiently large reaction system has not been available for earthquake engineering research.

Japanese researchers at the Building Research Institute, Tokyo, have been carrying out destructive static-cyclic tests on full-size apartment buildings up to five stories in height since 1967.<sup>2</sup> In most of the tests, repeated reversed lateral forces of a selected fixed pattern were used, and the magnitude of the forces was increased incrementally. The advantage of using this method is that after each increment the building can be subjected to both free and forced vibration by means of shakers, thereby making it possible, at each time step, to observe how period and damping vary with the amount of damage induced in the building. The results of these tests have clarified the probable seismic behavior of highly complex structures fabricated from cast-in-place reinforced concrete, precast reinforced concrete, and precast concrete with prestressed construction systems.

The testing facility used at the University of California, Berkeley, for studying the in-plane seismic behavior of wall and frame subassemblages has a capacity to test structures 12 m in height with an applied lateral force of 500 to 1,000 tons. A series of tests has been conducted on 1/3-scale models of wall subassemblages of a 10-story, reinforced concrete frame-wall structural system and of reinforced concrete frames infilled with reinforced masonry and braced-steel-frame planar subassemblages.<sup>1</sup>

The Portland Cement Association structures laboratory in Skokie, Illinois,<sup>3</sup> has a structural reactor system capable of accommodating specimens up to 5.5 m in height. By assembling groups of hydraulic rams, lateral forces of the order of 1,000 tons may be applied. Individual rams range in capacity and stroke up to 100 tons at 0.9-m stroke. An experimental program has been implemented to investigate the behavior of 1/3-scale models of reinforced concrete wall subassemblages.

The United States and Japan are now in the planning stages of a cooperative research program that will use a large-scale test facility recently constructed by the Japanese Government at their new Building Research Institute in Tsukuba New Town.<sup>4</sup> The physical test facility consists basically of two large testing floors with a large reaction wall between them. The reaction wall can be used for applying static or static-cyclic (pseudodynamic) lateral forces to structures anchored to either of the two test floors. Figure 1

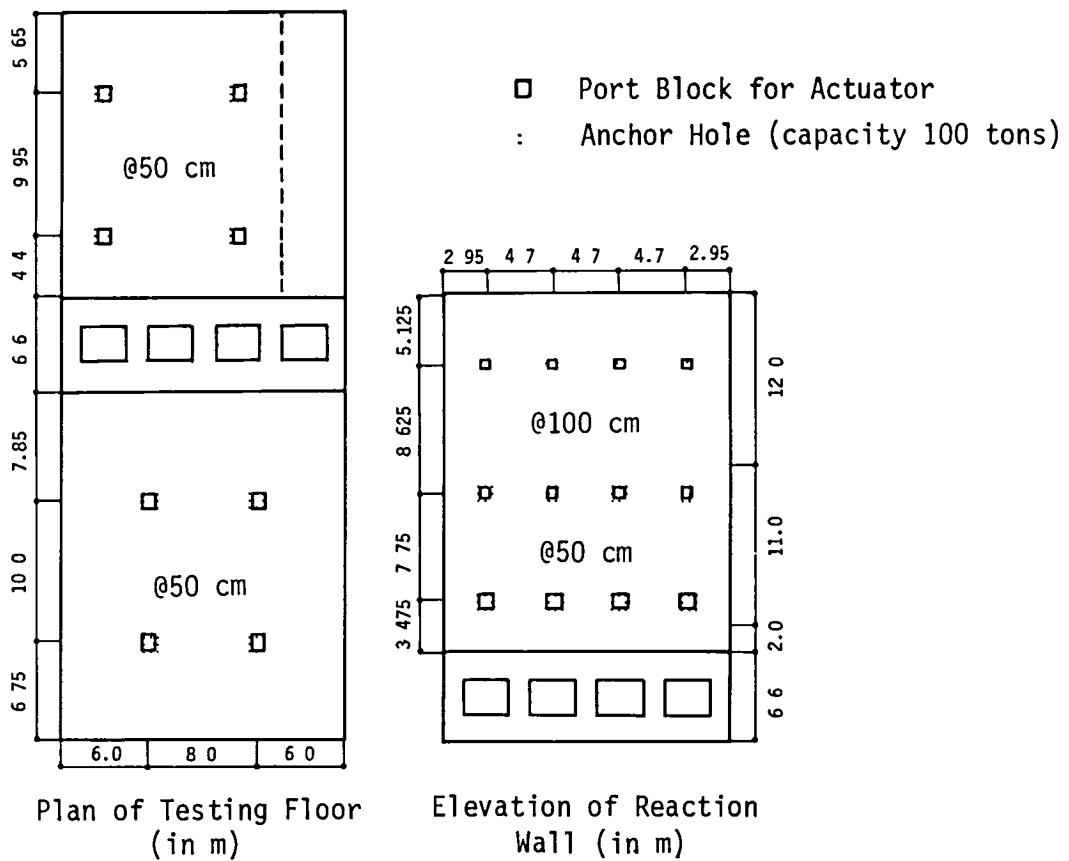

(A) Testing Floor and Reaction Wall

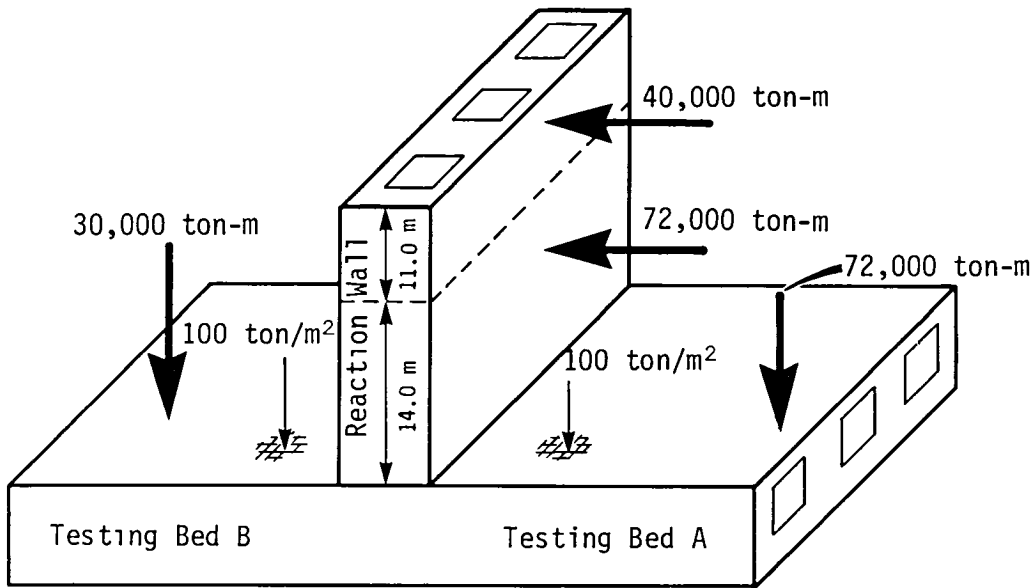

(B) Schematic View of Capacities of Testing Facility

FIGURE 1 STATIC-CYCLIC STRUCTURAL TESTING FACILITY: TSUKUBA NEW TOWN, JAPAN

shows a plan view of the testing floor and an elevation of the reaction wall, as well as a schematic view of the system's capacities.

One testing floor has a width of 20 m, a length of 24.6 m, and a depth of the tie-down floor of 6.6 m. The maximum shear force that can be carried by the floor is 4,000 tons, the maximum flexural moment is 72,000 ton-m, and the maximum vertical unit load on the test floor is 100 ton/m<sup>2</sup>. The other testing floor, which is on the opposite side of the reaction wall, has a width of 15.4 m, a length of 20 m, a depth of 6.6 m, a maximum shear force capacity of 1,500 tons, a maximum flexural moment of 30,000 ton-m, and a maximum vertical load of 100 ton/m<sup>2</sup>. The reaction wall has a height of 25 m, a width of 20 m, and a thickness of 6.6 m. The maximum shear force that the wall can carry is 4,000 tons, the maximum flexural moment above 14 m in height is 40,000 ton-m, and the maximum flexural moment 14 m in height is 72,000 ton-m.

A time schedule, covering the period 1978 to 1980, for the preparation of loading facilities and operating equipment for this new large-scale test facility is given in Table 1.

A facility that will permit three-dimensional controlled loading experiments to be conducted on large-scale models of subassemblages or buildings is being constructed at the Civil Engineering Research Laboratory, Balcones Research Center, University of Texas, Austin.<sup>1</sup> The facility consists of a structural floor-buttressed wall system that will be served by a computer-controlled data acquisition system and a closed-loop hydraulic loading system. This test facility was developed to conduct a comprehensive investigation of the behavior of reinforced concrete frame elements under biaxial loads. The use of floor-buttressed wall systems, together with specially constructed loading frames, will enable studies of multidirectional loading histories to be conducted on large three-dimensional subassemblages or 1- and 2-story full-scale three-dimensional structural systems. It would be highly desirable, particularly for studies of tall panelized buildings, to develop a similar facility with greater height capacity.

**TABLE 1**  
**TIME SCHEDULE FOR PREPARATION OF LOADING FACILITIES AND OTHER TESTING APPARATUS**  
**AT THE BUILDING RESEARCH INSTITUTE, TSUKUBA NEW TOWN, JAPAN**

Fiscal Year	Static Oil Jack			Actuator				Displacement Transducer			Data Processing System			Computer	Program
	Load Capacity (ton)	Stroke Limit (cm)	No Jacks	Load Capacity (ton)	Stroke Limit (cm)	Max Ram Speed (cm/sec)	No Actuators	Stroke Limit (cm)	Type	No Transducers	Data Recorded	No Channels	Reading Speed per Channel		
1978	100	±100	10	50	±30	35	1	±50	Inductance	20	Static strain	500	0.1 sec	24-kiloword (KW) core	Development of multi-computer system
	100	±30	10					±10	WSG	20					
	25	±30	2					±5	WSG	30	Dynamic strain	30	50 µsec		
	70	±30	12												
	70	±10	12*												
1979				100	±50	0 2	5				Feedback				Program for pseudodynamic test using two actuators
											Displacement of actuator	5			
											Displacement of test frame	5			
To May 1980				100	±100	0 2	2	±100	Digital (high sensitivity)	8	Feedback			Linkage to host computer (124 KW)?	Program for pseudodynamic test using more than eight actuators
											Displacement of actuator	2			
											Displacement of test frame	2			
											Load	2			

\*Center hole

NOTE The information presented in this table was provided by Professor Robert D Hanson, Civil Engineering Department, University of Michigan, Ann Arbor

## SHAKING TABLE TESTING

Shaking tables are capable of accurately reproducing ground or floor motions recorded either for historical earthquakes or during artificially generated earthquakes. Therefore, the most effective application of shaking tables is to obtain data on the nonlinear behavior and collapse mechanisms of full-scale structures and soil-structure systems subjected to simulated earthquake loading.<sup>1</sup>

Table 2 summarizes the characteristics of shaking tables used at research institutions in the United States, Japan, Canada, and Mexico. These tables have several limitations that restrict their application:

- Most shaking tables are capable of producing motion in only one direction at a time. Earthquake motions, however, are not unidirectional: six components are required to accurately reproduce earthquake motion. Some existing shaking tables are capable of simultaneous translation in one horizontal direction and the vertical direction, but cannot accommodate studies of biaxial effects.
- Existing shaking tables are inadequate for destructive testing of full-scale structures. A shaking table must have a stroke limit (maximum displacement) of at least 300 mm if it is to simulate the maximum dynamic ground displacements associated with many large earthquakes. It has been suggested that a shaking table will not be able to bring a full-scale test structure into collapse (or severe damage) if its stroke limit is less than 500 mm.<sup>5</sup> The displacement required to cause collapse is, of course, dependent upon the specific structure being tested. Furthermore, to perform tests of full-scale structures, a table motion frequency range of 0.1 to 20 Hz (0 to 40 Hz for 1/2-scale structures) is required, with peak velocities of at least 65 cm/sec.<sup>1</sup> At present, there are no shaking tables that meet these requirements.
- Although the largest shaking table currently available is capable of testing model structures that weigh up to 500 tons, the majority can test only those that weigh less than 50 tons. These models are small in comparison with many large structures.

The National Research Center for Disaster Prevention, Science and Technology Agency, Japan, has the world's only large (15-m x 15-m) shaking table.<sup>6</sup> This



TABLE 2  
SUMMARY OF CHARACTERISTICS OF SHAKING TABLES

Research Institution	Table Size (m)	Table Weight (ton)	Speciman Weight (ton)	Frequency Range (Hz)	Maximum Acceleration (fully loaded)	Displacement ± (mm)
United States						
University of California, Berkeley	6.1 x 6.1	50.0	54.5	DC - 20	0.67g (H) 0.33g (H) *	±127 (H) ±50 (V)
CERL (U.S. Army)	3.7 x 3.7	5.4	5.4	DC - 200	20g (H) 40g (V)	±100 (H, V)
University of Illinois	3.7 x 3.7	2.5	4.5	0.1 - 20	7g	±100
Wylie Laboratories, Huntsville	5.2 x 1.5		4.25	DC - 500	20g (H <sub>1</sub> , H <sub>2</sub> , V)	±140
Wylie Laboratories, Huntsville	4.25 x 2.1		2.9	DC - 400	3.5g (H&V)*	±200 (H&V)
Japan						
The National Research Center for Disaster Prevention	15 x 15	160	500 (H) 200 (V)	DC - 50	0.6g (H <sub>1</sub> ) 1.0g (V)	±30 (H, V)
Central Research Institute of Electric Power Industry	6.5 x 6.0	25	120	0.1 - 20	0.4g	±50
Japan Telephone and Telegraph Public Corporation	3.0 x 3.0	5	10	0.1 - 50	1.0g (H) 1.0g (V)	±100 (H) ±120 (V)
Kajima	4 x 4	8.5	20		1.2g (H) 2.0g (V)	±150 (H) ±75 (V)
Railway Technical Research Institute	10 x 2 x 3.2	22	78	0.1 - 20	0.4g	30
Mitsubishi	6 x 6	21	100	0.1 - 50	1.0g (H&V)*	50 (H&V)
Tokyo University	10 x 2 x 2	35	135	1.0 - 5.0		100
Ohbayashi Corporation	4 x 3	5	20	DC - 50	1.0g	100
Kyoto University	3 x 3		12	0.1 - 30	0.5g	50
Kyoto University	2.5 x 2.5		8	1.0 - 200	0.5g	50
Port and Harbor Research Institute	5.5 x 2 x 1.5	8	16	0.2 - 50	0.5g	50
Shimizu	4 x 5		20			
Canada						
Concordia University, Montreal	5.8 x 4.0	4.5	6.7	DC - 50	1.2g	±75
University of British Columbia	3.1 x 3.1	0.45	2.3	DC - 80	6.5g	±65
Mexico						
National University of Mexico	4.5 x 2.4	7.6	15.2	2.0 - 100	1.0g	±25

\*moves two directions simultaneously

table has a payload capacity of 500 tons in the horizontal plane and 200 tons vertically, and a frequency range of 0 to 50 Hz. However, because its maximum stroke is only 300 mm, the application of the table has been restricted to the study of the linear dynamic response of structures and systems.

Another large (15-m x 15-m) shaking table is being constructed in Japan by the Center for Nuclear Safety Engineering Research<sup>6</sup> and will be suitable for destructive testing of full-scale structures. The table is designed to carry a payload of 1,000 tons, with a frequency range of 0 to 30 Hz, a maximum horizontal acceleration of 1.8g, and a vertical acceleration of 0.9g. It will be able to produce motion in both directions simultaneously. The stroke will have a  $\pm 200$ -mm horizontal limit and  $\pm 100$ -mm vertical limit, with a maximum horizontal velocity of 75 cm/sec and a maximum vertical velocity of 37.5 cm/sec.<sup>1</sup> It is proposed to use this shaking table to measure the dynamic response of prototype nuclear power plant components and models, including pressure vessels.<sup>6</sup>

It would be desirable to develop a shaking table that would permit testing of structures weighing up to 2,000 tons and would be capable of producing a velocity in the horizontal direction of about 150 cm/sec. A simulator of this type would facilitate investigations of soil-structure interaction because it would permit many layers of soil to be built up on the table. For example, such a shaking table, in addition to accommodating soil layers that are 12.2 m x 12.2 m in plan, 4.6 m in depth, and 1.3 tons in weight, could still have a reserve capacity of 0.7 tons for the structure model. Tests could therefore be performed on full-scale models of single-bay structures up to ten stories in height.

There are more than 20 medium-size ( $10\text{-m}^2$  to  $40\text{-m}^2$ ) shaking tables in the world today. However, only three can produce motion in two directions simultaneously, and the most capable of these has a maximum stroke of 200 mm, which may not be sufficient to test the components of some full-size structures to failure or even to test severe damage in many cases. Furthermore, none of the medium-size tables can be used to carry out studies of the behavior of actual soil-structure systems.<sup>1</sup>

The two largest shaking tables in the United States are both medium-size. One is operated by the University of California, Berkeley, and the other by the U.S. Army's Civil Engineering Research Laboratory (CERL) at Champaign, Illinois.<sup>1</sup> The Berkeley table has an area of 6.1 m x 6.1 m and is capable of vibrating a payload of 54.5 tons with a frequency range of 0 to 25 Hz, a maximum horizontal acceleration of 0.33g, and a vertical acceleration of 0.5g; it produces motion in both directions simultaneously. The stroke limit is  $\pm 127$  mm horizontal and  $\pm 50$  mm vertical. This shaking table has been used extensively, mostly for scale model testing of civil structures and soils, but some full-scale testing of small structures has been conducted. The CERL shaking table has an area of 3.7 m x 3.7 m and a payload capacity of 5.4 tons. It is also capable of two directions of motion. The frequency range of the table is 0 to 200 Hz, the maximum stroke is  $\pm 100$  mm in both directions, and the maximum acceleration is 20g horizontal and 40g vertical. The application of the CERL table has been largely restricted to testing of systems designed for national defense use.

The Port and Harbor Research Institute of Japan has constructed small-scale models of quay walls in test bins placed on shaking tables and has used vertical actuators to consolidate clay specimens from a slurry behind the quay wall.<sup>6</sup> However, small-scale simulation of body force and capillarity parameters is extremely difficult in shaking table tests of soils.

#### VIBRATION GENERATOR TESTING

Sinusoidal-vibration rotating-mass and reciprocating-mass generators have been used to measure the elastic dynamic characteristics of many structures: medium- and high-rise steel-reinforced concrete buildings; earth-filled dams; a concrete-arch dam; intake towers for dams; bridge structures; and nuclear reactor structures. Many of these investigations have been described and referenced by Hudson<sup>7</sup> and by Shepherd and Jennings.<sup>8</sup>

The Central Research Institute of the Electric Power Industry, Japan, has constructed an unbalanced-mass vibration generator that is used for field measurement of nuclear power plants to determine their vibration characteristics.<sup>6</sup> The system is capable of inducing an inertial force of 500 tons at a frequency of 10 Hz.

In recent tests, full-scale multistory buildings have been deliberately forced into severe inelastic response by means of unidirectional horizontal moving-mass vibration generators.

Destructive testing of a 4-story reinforced concrete bare-frame structure at the U.S. Department of Energy's Nevada Test Site resulted in a permanent change in the damping and stiffness characteristics of the structure, which has been correlated with observable damage.<sup>9</sup> A hydraulic reciprocating-mass vibration generator weighing 5.9 tons, with an operating frequency range of 0 to 40 Hz and a maximum piston force capacity of 5.5 tons at 3 Hz, was used to load the structure to the inelastic range. A counterrotating-mass vibration generator with a smaller capacity was also used for modal analysis. Four structural modes of vibration were excited separately, and the dynamic characteristics of each mode were determined.

An 11-story reinforced concrete frame building of the Pruitt-Igoe housing complex of St. Louis, Missouri, was subjected to many cycles of large-amplitude shaking by an exciter capable of generating an inertial loading of 13.6 tons over a frequency range of 0.5 to 10 Hz and a maximum piston displacement of  $\pm 280$  mm. The shaker was driven by two electric motors weighing 4.5 tons each. The induced vibration resulted in severe damage to many beam-column joints and maximum top-story displacement of approximately  $\pm 400$  mm.<sup>10</sup>

#### UNDERGROUND EXPLOSION TESTING

Conventional high explosives or nuclear devices can be detonated underground to produce a wave-propagation environment with ground motion amplitudes and frequencies similar to those from earthquakes. Control of this environment -- that is, control of amplitude, frequency, and duration -- is possible through enhancement techniques such as sequential firing, geographic distribution of blast arrays, and placement of relief trenches.<sup>11,12</sup>

Although explosives have been used and studied by the defense and blasting industries for at least 30 years, their application to earthquake engineering research is more recent and has been carried out at only a few test sites in the Soviet Union<sup>13</sup> and the United States.<sup>14</sup>

The Soviet Union has been using sequentially fired detonations to evaluate the structural response of dams and full-scale buildings for at least the past decade.<sup>13</sup> The U.S. Geological Survey is currently coordinating U.S. and Soviet studies of the effect of sequentially fired explosions on a prototype multistory building.<sup>15</sup>

The dynamic response of two 4-story reinforced concrete test structures and many 1- and 2-story test structures to underground nuclear explosions at the U.S. Department of Energy's Nevada Test Site has been investigated by URS/John A. Blume & Associates, Engineers,<sup>16</sup> of San Francisco over the period 1965-1975. Results have contributed to improved dynamic modeling techniques and a better understanding of the effects of nonstructural partitions and soil-structure interaction.<sup>16</sup> However, in these tests no attempt was made to produce specific characteristics of earthquake ground motion.

During 1971, at the University of California, Los Angeles, field station in Oak Spring Canyon, several arrays of sequential, small-scale dynamite blasts were used to simulate earthquake conditions for testing a 3-story structure located 30 m from the blast center.<sup>17</sup> Three variables were studied: the effects of a charge's size, detonation rate, and bulk strength on the frequency content of the ground motion; the effect of distance on the attenuation of the ground motion; and the effect of blast duration using time-delayed dynamite caps on the duration of ground motion at the test site. Variations in charge size caused small differences in the response of the base structure and produced significant changes in overall structural response. It was demonstrated that matching the bulk strengths of different types of dynamite is a valid method for obtaining uniformity of response. Time delays were found to extend the duration of motion; the effect was amplified when explosives with faster detonation rates were used.<sup>17,18</sup>

Charges of high explosives buried near the foundation slab of a circuit breaker of the type used in nuclear power plants were detonated for the purpose of performing a seismic qualification test program.<sup>19</sup> The tests were carried out by Applied Nucleonics Company, Inc., of Los Angeles, in 1972-1973. The explosive blasts were used to simulate particular aspects of a strong-motion earthquake with a specified maximum amplitude.

The use of underground explosions to simulate earthquakes is particularly suitable for experimental problems concerning soil and soil-structure systems. These systems are composed of, or are surrounded by, the medium through which the seismic waves propagate and therefore cannot be evaluated independently of the free-field medium.

The University of New Mexico's McCormick Ranch Test Site, located south of Albuquerque, New Mexico, was used as the site for an experimental program (sponsored by the Electric Power Research Institute) to simulate earthquake ground motion for the investigation of dynamic soil-structure interaction.<sup>12</sup> A small-scale experiment was conducted in 1977 to evaluate the effectiveness of using sequential explosions to simulate earthquake ground motion for investigation of its effects on embedded cylindrical structures. These tests, designed to assess the feasibility of a large-scale experimental program, led to the conclusion that reasonable simulation of earthquake motion for soil and soil-structure systems is possible with the use of explosive arrays, alone or in combination with enhancement techniques.<sup>12</sup>

The Corral Hollow Experimental Site of the Stanford Research Institute at Palo Alto, California, is currently being used to develop a technique to simulate earthquakes for large-scale testing of structures and systems.<sup>20</sup> This program, sponsored by the National Science Foundation, involves the simultaneous detonation of a line of constant-elevation downhole explosives to generate a plane wave. Subsequent sequential detonations of explosives down the same holes are controlled and timed to produce the required earthquake characteristics in the resultant superposition of plane waves.

#### SOIL DYNAMICS TESTING

Information about the following major soil properties is needed in earthquake engineering:

- Dynamic moduli - Young's modulus, shear modulus, bulk modulus, and constrained modulus
- Poisson's ratio
- Damping and attenuation

- Liquefaction parameters - cyclic-shearing stress ratio, cyclic deformation, and pore-pressure response
- Shearing strength in terms of strain-rate effects

Some of these soil properties are best studied in the field, others in the laboratory, and some can be measured in both the laboratory and the field.

### Laboratory Testing

Some laboratory tests are designed to measure specific basic soil properties like shearing strength or shear modulus, while others are designed to determine soil behavior in a simulated earthquake environment.

The resonant-column test for determining moduli and damping characteristics of soils is based on the theory of wave propagation in prismatic rods. Either compression waves or shear waves can be propagated through the soil specimen, from which either Young's modulus or the shear modulus can be determined.<sup>21,22,23</sup> In a resonant-column apparatus the exciting frequency is adjusted until the specimen experiences resonance. The modulus is computed from the resonant frequency, the geometric properties of the specimen, and the driving apparatus. Damping is determined by turning off the driving power at resonance and recording the decaying vibrations.

Several versions of the resonant-column test are possible using different end conditions to constrain the specimen, but all devices measure relatively consistent properties.<sup>23</sup>

The ultrasonic pulse test uses piezoelectric crystals to generate and receive ultrasonic waves in soils. The crystals can generate either compression or shear waves. By timing the travel of these waves over a fixed distance, the wave velocities and hence the soil moduli can be computed. Currently, this technique is not widely used in soil dynamics, but it is routinely used to measure the dynamic properties of rock.<sup>24</sup>

Cyclic triaxial, simple shear, and torsional shear tests are used in many laboratories in both Japan and the United States to evaluate settlement and liquefaction potential of soils due to vertically propagating shear

waves.<sup>6,21,22,23,25</sup> These tests also permit evaluation of moduli and material damping.

The liquefaction characteristics of sands have also been evaluated in a large-scale simple shear test using a shaking table for excitation.<sup>6,25</sup>

In addition, the dynamic behavior of cohesive soils has been determined by evaluating the behavior of blocks of material during either forced or free vibration.<sup>21</sup> During forced vibration, the top of a 300-mm x 300-mm x 150-mm block of soil was loaded axially and deformed in a cyclic manner while the base of the block was restrained. The free-vibration test was performed by either deforming the top of a block laterally or exciting the block on a shaking table.

These laboratory techniques are tabulated in Table 3, where the specific properties or characteristics measured by each are indicated.

Dynamic laboratory techniques may be classified according to whether they are low-frequency or high-frequency tests. The cyclic testing and forced- or free-vibration methods generally operate at the frequency range of 0 to 30 Hz. Typically 1 to 300 cycles of loading are applied during these soil sample tests. Ultrasonic and the various resonant-column tests operate at much higher frequencies and at low strain amplitudes. A comparison of these dynamic test methods, showing the soil properties measured and the stress conditions during the test, as well as the nature of dynamic loading and strain amplitude applied, are shown in Table 4.

Centrifugal testing shows promise in the study of some aspects of soil behavior during earthquakes, but only a few dynamic tests have been reported.<sup>26</sup> This is a relatively new test technique, and it has not been widely used. It is difficult to simulate dynamic excitation in the small-scale centrifuge environment: to produce at corresponding points in a small-scale model the unit stresses, velocities, moduli, and strains that exist in the full-scale structure, the weight of the model must be increased (by use of centrifugal force) in the same ratio (N) as that used to decrease the scale of the model with respect to the full-scale (prototype) structure. The soil used in the model is the same as that in the prototype.



TABLE 3  
LABORATORY TECHNIQUES FOR MEASURING DYNAMIC SOIL PROPERTIES

Laboratory Technique	Shear Modulus	Young's Modulus	Material Damping	Cyclic Stress Behavior	Attenuation
Resonant Column with adaptation	X	X	X		X
Ultrasonic Pulse	X	X			X
Cyclic Triaxial		X	X	X	
Cyclic Simple Shear	X		X	X	
Cyclic Torsional Shear	X		X	X	
Shaking Table	X			X	
Forced and Free Vibration		X	X		

**TABLE 4**  
**COMPARISON OF DYNAMIC TEST METHODS**

Type of Test	Soil Property Measured†	Stress Conditions During Test	Type of Cyclic Load	Initial Stress on Sample	Typical Test Frequency (Hz)	Typical Strain Amplitude (%)	Typical Number of Cycles
<b>Low-Frequency Dynamic Tests:</b>							
Cyclic Triaxial	E and D	Pulsating Axial or Confining Pressure	Constant Stress	Triaxially Consolidated	1 - 5	$10^{-2}$ - 10.0	1 - 300
Cyclic Shear	G and D	Simple Shear	Constant Stress or Strain	Axially Loaded	1 - 3	$10^{-2}$ - 0.5	1 - 300
Cyclic Torsion	G and D	Simple Shear	Constant Stress or Strain Free Vibration	Triaxially Consolidated	0 - 30	$10^{-2}$ - 1.0	1 - 300
Forced and Free Vibration	G and D	Simple Shear	Constant Stress or Strain Free Vibration	Axially Loaded	1 - 10	$10^{-2}$ - 3.0	1 - 300
<b>High-Frequency Dynamic Tests:</b>							
Ultrasonic Tests	$V_p$ and E	Dilational Wave	Constant Stress	Triaxially Consolidated	>10,000	$10^{-4}$	Single Transient Pulse
Resonant Column Wilson Device*	$V_s, V_p, E, G$	Distortional or Dilational Wave	Constant Strain	Isotropically Consolidated	50 - 500	$10^{-4}$ - $10^{-3}$	>1,000
Longitudinal Hall Device*	$V_s, G, D$	Distortional Wave	Constant Strain	Isotropically Consolidated	80 - 500	$10^{-4}$ - $10^{-3}$	1,000
Torsional Hardin Device*	$V_s, G, D$	Distortional Wave	Constant Strain	Triaxially Consolidated	200 - 500	$10^{-4}$ - $10^{-3}$	3,000
High-Amplitude Torsional Device	$V_s, G, D$	Distortional Wave	Constant Strain	Isotropically Consolidated	25 - 100	$10^{-3}$ - $10^{-1}$	300 - 100,000

\*These apparatus have different boundary conditions and different strain amplitude capabilities (see Reference 21).

†The different types of soil properties measured are defined as follows:

D = Damping	$V_p$ = Dilational Wave Velocity
E = Young's Modulus	$V_s$ = Distortional Wave Velocity
G = Shear Velocity	

The mechanical limitations of centrifuge apparatus usually restrict the weight of the model to less than 0.5 tons. Therefore, it is generally necessary to carry out tests at scales of about 1/100, which requires that the model be subjected to 100g centrifugal force. At this scale, the frequencies of the simulated ground motion that must be applied in a dynamic test are 100 times those of the prototype. The duration of model earthquakes is 100 times shorter than the duration of actual earthquakes, and acceleration is 100 times greater. Thus, for example, at this scale, the model of an earthquake with a 10-sec duration, a peak acceleration of 0.5g, and earthquake frequencies up to 15 Hz would have vibration of 0.1-sec duration, a peak acceleration of 50g, and frequencies of up to 1,500 Hz. Therefore, in order to simulate a real-world earthquake, a vibration generator with these vibration characteristics must be attached to the test specimen inside the rotating centrifuge.

The Soviet Union has been using centrifuges to provide an artificial gravity environment for small-scale models for 45 years. In Great Britain and Europe, centrifuge model testing began with Roscoe and Schofield in the late 1960s. Recently, the United States and Japan have also responded to the growing interest in the technique.<sup>6,27</sup>

Table 5 summarizes the characteristics of centrifuges surveyed for this appendix.

A centrifuge that will have a larger capacity than any current centrifuge is being developed at the National Aeronautics and Space Administration's Research Center (NASA/Ames), Moffett Field, California. This centrifuge will be coordinated with the Geotechnical Centrifuge Laboratory of the University of California, Davis, where a (smaller) Schaevitz centrifuge, designed to model the dynamic response of earth embankments, dams, and nuclear reactor sites to simulated earthquakes,<sup>27,28</sup> is being used to test the performance of a lightweight piezoelectric shaker. The shaker is being considered in the development of an earthquake simulator suitable for incorporation into the NASA/Ames centrifuge.

TABLE 5  
SUMMARY OF CHARACTERISTICS OF CENTRIFUGES

Research Institution	Radius of One Swing (m)	Payload Capacity (g-ton)	Typical Net Payload (ton)	Maximum Centrifugal Acceleration (g)
NASA/Ames, Moffett Field* (Mode 2 - to be developed)	6 - 7.6 10.8	900 2,000	3 20	300 100
Cambridge University, England*	5.0	83	0.66	125
University of California, Davis (Schaevitz)*	1.0	5	0.05	100
Boeing, Seattle*	1.4	60	0.25	600
Sandia Corporation, Albuquerque	10.8 7.6	225 800	5 8	45 100
University of Florida	1.0	3	0.03	100
University of Colorado, Boulder	1.4	10	0.1	250
Goddard Space Flight Center*	18.3	75	2.5	30
California Institute of Technology	1.0	5	0.05	175
University of Manchester, England	6.0	400	2	180
Draper Company Laboratory, Massachusetts (installed 1955)	10.0	100	1	100

\*A dynamic exciter incorporated to enable dynamic modeling (all restricted to sinusoidal input).

## Field Testing

Field testing techniques deal with either the measurement of wave velocities propagating through the soil or the response of soil-structure systems to dynamic excitation.

The *seismic crosshole survey* (SCS) is now generally recognized as one of the few reliable field methods for obtaining information about seismic velocities, and hence dynamic moduli, of in-situ soils. The method involves generating seismic waves at a particular depth in one boring (energy hole) and recording the arrivals of seismic waves at the same depth in one or more other borings (receiving holes). Velocity transducers (geophones) are well suited as seismic receivers in the SCS.

The different mechanisms used to generate the seismic waves can be grouped into two general categories: (1) explosive sources, which include blasting agents, air guns, gas guns, sparkers, and similar devices; and (2) mechanical sources, which include a hammer striking a pipe that extends from the surface to the bottom of a boring, downhole devices involving mechanical hammers or vibrators, and falling weights that drop onto the bottom of borings. The Central Research Institute of the Electric Power Industry, Japan, has developed a vibration generator for use in measuring the in-situ moduli and damping values of soil. The vibrator is designed to generate a maximum inertial force of 50 tons over the frequency range of 0.01 to 10 Hz when embedded in soil.<sup>6</sup>

Within the engineering profession, there are some controversies regarding the reliability of each type of source to produce meaningful results.<sup>22</sup> It is generally agreed that explosive sources produce well-defined compressional *P*-wave arrivals, but the arrivals of the slower traveling shear *S*-waves are less obvious. Hence, there is some question as to the ability of the explosive method to produce accurate *S*-wave velocities. Although mechanical sources produce clearly definable *S*-wave arrivals with more consistency than the explosive source, *P*-wave arrivals are not as distinct and can be subject to question. There is also some concern that the frequency content from the two sources may be significantly different, thereby influencing velocity determinations because of emergent arrivals of low-frequency energy or dispersion within the materials.

Fugro Inc., of Long Beach, California, has carried out five crosshole-type seismic surveys,<sup>22</sup> each employing two commonly used seismic-wave-generation sources (explosive and mechanical) to evaluate the reliability of each source technique to produce comparable seismic velocities. Each site was the proposed location of a nuclear power station, but soil profiles differed considerably. Comparison of the resulting velocities (compressional and shear) produced by the two different sources indicated that quite similar results can be obtained when proper field and interpretation procedures are used.<sup>22</sup>

*Seismic downhole survey* techniques require only one borehole. Single or multiple receivers are lowered into the borehole and clamped at preselected depths with predetermined orientations. An impulse is generated at the surface of the ground near the top of the borehole, and travel times of the body waves between the surface and downhole receivers are measured. Low-velocity layers can be detected even if trapped between higher-velocity layers, provided that geophone spacing is close enough. Reversing the position of the source and receivers changes the configuration to a seismic uphole survey.

The major disadvantages of seismic downhole surveys are that it is difficult to generate waves of the desired type and that the *P*-wave to *S*-wave amplitude ratio is heavily weighted toward the *P*-wave.

*Horizontally polarized shear waves (SH-waves)* are the most useful wave sources and should be reversible for optimum results. Hand-powered sources are satisfactory for near-surface exploration, while larger mechanical sources are necessary for deeper investigations.

URS/John A. Blume & Associates, Engineers, of San Francisco<sup>29</sup> has performed a set of attenuation measurements of *S*-waves generated at the surface in sandstones and shales on the site of an existing West Coast nuclear power plant. The approach was to observe the decay of amplitude with depth for selected frequency components of *S*-waves generated at the surface. The downhole pulse, which was generated by a hammer blow, was of the order of 100 Hz. In addition, continuous borehole velocity logs were obtained from a sonde that generated a pulse of about 35 kHz.

The *seismic refraction survey* (SRS) is well suited for general site investigations for earthquake engineering purposes: a wave source is activated, and the velocities of the generated waves are measured with geophones located on the ground surface at a measured distance from the source. The SRS method enables the determination of elastic wave velocities in each soil layer and the thickness and dip angles of each layer, as long as the wave velocities increase in each succeeding soil layer. Low-velocity layers trapped between higher velocity layers may be missed if the velocity contrasts are large.<sup>30</sup>

One well-known technique used to generate desirable shear waves is to spike a plank to the ground, weigh down the plank, and strike the end of the plank with a hammer. The advantage of the SRS method is that it can be performed from the ground surface and can be used to investigate large areas quite rapidly.

An *electrical sensing probe* that can be driven into soil to a fixed depth so that the probe elements contact a sample of the soil to be evaluated has been designed at the University of California, Davis.<sup>31</sup> The probe is equipped with a minicomputer that can be used to measure the properties of soil by passing an electrical current through the soil sample. Methods for deduction of soil parameters such as the stress ratio required to cause liquefaction, the friction angle, permeability, and dynamic settlement from the measured electrical properties have been proposed.

The *standard penetration test* (SPT) is an accepted means of assessing liquefaction potential in fine to medium sands and is being used in China and the United States for this purpose.<sup>23</sup>

Other field techniques used for measuring dynamic soil properties include the *resonant-footing technique* for evaluating shear modulus of a soil using a torsional resonant footing; the *cylindrical in-situ test* (CIST), which consists of instrumenting a field with accelerometers and detonating explosives in a central hole to measure soil properties and constitutive relations; the *water cannon technique*, by which the soil response to an impulse load applied by a water cannon is measured<sup>23</sup> and the impulse created by blasting the water out of the tube with an explosive charge is compared with

the vertical response of the system in order to determine the dynamic stiffness of the supporting medium.

The principal features of these field techniques for measuring dynamic soil properties are presented in Table 6.

In comparison to the many field tests performed to measure dynamic soil properties, relatively few field tests have been performed to study the response of soil-structure systems to dynamic excitation.

*Excitation of model footings* to produce motions comparable with permissible motions of prototype footings has been used as a field testing technique for studying soil-structure response. Such a program has been carried out by the U.S. Army Engineer Waterways Experiment Station at Vicksburg, Mississippi, and at Eglin Field, Florida.<sup>32</sup> For these tests, circular concrete footings, 1.5 m to 4.9 m in diameter, were set into steady-state vibration by a rotating-mass mechanical vibrator. The modes of vibration consisted of vertical translation, torsional oscillation, and rocking about a horizontal axis. The results of the tests have been analyzed by Richart and Whitman.<sup>33</sup>

The 9-story reinforced concrete Millikan Library building on the campus of the California Institute of Technology has been the subject of a series of forced-vibration tests. The amplitudes of motion in the far-field region were recorded along 11 lines that radiated from the building, extending to 6.4 km.<sup>34</sup> The series of vibration tests on the two 4-story test structures at the U.S. Department of Energy's Nevada Test Site included measurements of free-field motion in the immediate vicinity of the structures.<sup>35</sup> The U.S. Army Engineer Waterways Experiment Station at Vicksburg, Mississippi, has used a 22-ton vibration generator<sup>36</sup> to excite embankments and buildings in both horizontal and vertical modes in order to evaluate transfer functions and to define soil-structure interaction.<sup>37</sup>

Reliable techniques are now available for both laboratory and field evaluation of dynamic soil properties and behavior. However, combining results from both laboratory and field has often been disappointing or impossible because of the large differences between them.



TABLE 6

FIELD TECHNIQUES FOR MEASURING DYNAMIC SOIL PROPERTIES

Field Technique	P-wave Velocity	S-wave Velocity	Other Measurements	Advantages	Disadvantages
Refraction	X	X	Depths and slopes of layers	Reversible polarity with SH-SRS. Works from surface. Preliminary studies.	Misses low velocity zones and low strain amplitudes. Properties measured are for thin zones near boundaries.
Crosshole (In-situ Impulse Test)	X	X	Velocity as function of strain amplitude	Known wave path. Reversible polarity. Works in limited space. Finds low velocity.	Requires 2 or more holes. Holes must be surveyed for verticality. Requires short-time-interval resolution.
Downhole or Uphole	X	X			
Surface		X	Attenuation of Raleigh waves	Works from surface.	Uncertain about effective depth. Requires large vibrator.
SPT			Empirical correlation with liquefaction	Widely available. Widely used in past.	Requires "Standardization."
Resonant Footing			Modulus of near-surface soils	Works from surface.	Limited depth of influence.
Water Cannon			Dynamic stiffness of support	Works from surface.	Apparatus and analysis very elaborate.
CIST	X	X	Constitutive equation	Wide amplitude range.	Very elaborate.

To narrow the gap between field and laboratory data it is necessary to eliminate the effects of disturbance in field sampling and develop uniformity in laboratory specimen preparation and testing.

## APPENDIX D - REFERENCES

1. Bertero, V. V., R. W. Clough, and M. Oliva, "Use of Earthquake Simulators and Large-Scale Loading Facilities in ERCBC," *Proceedings of a Workshop on Earthquake-Resistant Reinforced Concrete Building Construction*, University of California, Berkeley, July 1977.
2. Bertero, V. V., *Identification of Research Needs for Improving Aseismic Design of Building Structures*, Report No. EERC 75-27, Earthquake Engineering Research Center, University of California, Berkeley, 1975.
3. Oesterle, R. G., et al., *Earthquake Resistant Structural Walls - Tests of Isolated Walls*, PCA R/D Ser. 1571, Research and Development Construction Technology Laboratories, Portland Cement Association, Skokie, Illinois, November 1976.
4. URS/John A. Blume & Associates, Engineers, Job File No. 7904, personal communication, from R. D. Hanson, Civil Engineering Division, University of Michigan, Ann Arbor, to R. E. Scholl, URS/John A. Blume & Associates, Engineers, San Francisco, March 1979.
5. Watabe, M., "Comments on the Shaking Table at Tsukuba, Japan," *Earthquake Environment Simulation - Final Report and Proceedings of Earthquake Effects on Structures*, San Francisco, September 1973, published by National Academy of Engineering, Washington, D.C., 1974.
6. Silver, M. L., *Review of Cyclic Triaxial Testing Procedures and Shaking Table Test Facilities in Japan*, Department of Materials Engineering, University of Illinois, Chicago, December 1975.
7. Hudson, H. E., "Dynamic Tests of Full-Scale Structures," *Earthquake Engineering*, edited by R. L. Wiegel, Prentice-Hall, New Jersey, 1970.
8. Shepherd, R., and P. C. Jennings, "Experimental Investigation: Correlation with Analysis," *Proceedings of a Workshop on Earthquake-Resistant Reinforced Concrete Building Construction*, University of California, Berkeley, July 1977.

9. Chen, C. K., R. M. Czarnecki, and R. E. Scholl, "Destructive Vibration Test of a 4-Story Concrete Structure," Paper No. SP-55-24, *Douglas McHenry International Symposium on Concrete and Concrete Structures*, Publication No. SP-55, American Concrete Institute, Detroit, 1978.
10. Galambos, T. V., and R. L. Mayes, *Dynamic Tests of a Reinforced Concrete Building*, Research Report No. 51, School of Engineering and Applied Science, Department of Civil Engineering, Structural Division, Washington University, St. Louis, June 1978.
11. Kuznetsov, G. V., and V. P. Ulybin, *Change in the Magnitude of the Seismic Effect of Quarry Blasts as a Function of Various Factors*, translated from the Russian, No. FTD-HC-23-1569-74, Foreign Technology Division, 1974.
12. Higgins, C. J., and G. E. Triandafilidis, "The Simulation of Earthquake Ground Motions with High Explosives," *Proceedings*, Sixth World Conference on Earthquake Engineering, New Delhi, January 1977.
13. Rojahn, C., and S. H. Negmatollaev, "Forced Vibration Tests of a Three-Story Reinforced Concrete Frame and Shear-Wall Building in Tadzhiz S.S.R.," *Proceedings of the American Society of Civil Engineers Engineering Mechanics Division Specialty Conference on Dynamic Response of Structures*, University of California, Los Angeles, 1976.
14. *Evaluation of In-Situ Testing Methods for High-Amplitude Dynamic Property Determination*, Report No. NT-920, Research Project 769-2, Electric Power Research Institute, Palo Alto, November 1978.
15. *Research Needs and Priorities for Geotechnical Earthquake Engineering Applications*, edited by K. L. Lee, W. F. Marcuson III, K. H. Stokoe, Jr., and F. Y. Yokel, University of Texas, Austin, June 1978.
16. URS/John A. Blume & Associates, Engineers, *Influence of Nonstructural Partitions on the Dynamic Response Characteristics of Structures*, Report No. JAB-99-94, San Francisco, July 1972.

17. Mills, P. H., "Blast Dynamics of a Model Structure," Master's thesis, School of Engineering and Applied Science, University of California, Los Angeles, 1972.
18. Chrostowski, J., et al., *Simulating Strong Motion Earthquake Effects on Nuclear Power Plants Using Explosive Blasts*, Report No. UCLA-ENG-7119, Nuclear Energy Laboratory, Earthquake Engineering and Structures Laboratory, School of Engineering and Applied Science, University of California, Los Angeles, February 1972.
19. Applied Nucleonics Company, Inc., *Seismic Proof Tests Using Strong Ground Motion Produced by Explosions*, Report No. 1060-5, Los Angeles, August 1973.
20. "Simulation of Strong Earthquake Motion with Contained Explosion Line Source Arrays," Stanford Research Institute, Palo Alto, interim report, March 1979 (to be published).
21. Anderson, D. G., "Dynamic Modulus of Cohesive Soils," Ph.D. dissertation, No. UMEE-74RZ, Department of Civil Engineering, University of Michigan, Ann Arbor, June 1974.
22. McLamore, V. R., D. G. Anderson, and C. Espana, "Crosshole Testing Using Explosives and Mechanical Energy Sources," *Dynamic Geotechnical Testing*, special publication STP654, American Society for Testing and Materials, Baltimore, 1978.
23. Woods, R. D., "Measurement of Dynamic Soil Properties," *Earthquake Engineering and Soil Dynamics: Proceedings of the ASCE Geotechnical Engineering Division Specialty Conference*, Vol. 1, Pasadena, California, June 1978.
24. Obert, L., and W. I. Duvall, *Mechanics and the Design of Structures in Rock*, Wiley & Sons, Inc., New York, 1967.

25. Silver, M. L., *Laboratory Triaxial Testing Procedures to Determine the Cyclic Strength of Soils*, Report No. NUREG 0031, Division of Reactor Safety Research, Office of Nuclear Regulatory Research, U.S. Nuclear Regulatory Commission, Washington, D.C., June 1977.
26. Pokrovsky, G., and I. Fyodorov, *Centrifugal Testing in the Construction Industry*, draft translation, U.K. Building Research Establishment, Vol. I and II, 1975.
27. U.C. Davis - ARC-NSF Geotechnical Centrifuge: *Centrifuge Facility for Research in Geotechnical Engineering*, Department of Civil Engineering, University of California, Davis, January 1979.
28. Arulanandan, K., "Need for Research and Development of Large-Capacity Shakers for Dynamic Centrifuge Modeling," Department of Civil Engineering, University of California, Davis (in preparation).
29. URS/John A. Blume & Associates, Engineers, *Research Proposal for Development of Field Techniques to Measure Damping Values for Near-Surface Rocks and Soils*, program solicitation NSF 78-22, Earthquake Hazards Mitigation, San Francisco, September 1978.
30. Redpath, B. B., *Seismic Refraction Exploration for Engineering Site Investigation*, Technical Report TR E-73-4, U.S. Army Engineer Waterways Experiment Station, Explosive Excavation Research Laboratory, Livermore, California, NTIS AD-768710, May 1973.
31. "Invention Can Help Engineers Determine Reaction of Some Soils During Quakes," *University Bulletin* (publication for faculty and staff), Vol. 26, No. 12, University of California, Berkeley, January 9, 1978.
32. Fry, Z. B., *Report 1: Development and Evaluation of Soil Bearing Capacity; Foundations of Structures, Field Vibratory Test Data*, Technical Report No. 3-632, U.S. Army Engineer Waterways Experiment Station, Vicksburg, Mississippi, 1963.

33. Richart, F. E., and R. V. Whitman, "Comparison of Footing Vibration Tests with Theory," *Journal of the Soil Mechanics and Foundations Division*, American Society of Civil Engineers, Vol. 93, No. SM6, 1967.
34. Wong, H. L., J. E. Luco, and M. D. Trifunac, "Contact Stresses and Ground Motion Generated by Soil-Structure Interaction," *Michigan International Journal of Earthquake Engineering and Structural Dynamics*, Vol. 5, Ann Arbor, 1977.
35. URS/John A. Blume & Associates, Engineers, "Applications in Soil-Structure Interaction," San Francisco (in preparation).
36. *Summary of Capabilities*, U.S. Army Engineer Waterways Experiment Station, special publication, Vicksburg, Mississippi, 1978.
37. URS/John A. Blume & Associates, Engineers, Job File No. 7904, personal communication, from P. Hadala, Head, Earthquake Engineering Division, Geotechnical Laboratories, U.S. Army Engineer Waterways Experiment Station, Vicksburg, Mississippi, to T. A. Moore, URS/John A. Blume & Associates, Engineers, San Francisco, April 4, 1977.

## **APPENDIX E**

### **Test Equipment and Facilities at NASA/MSFC**



## Test Equipment and Facilities at NASA/MSFC

The test facilities at NASA/MSFC were designed to satisfy aerospace vehicle development needs. Since the beginning of the space program, the testing organization at MSFC has been developing and evolving sophisticated test techniques, principles, equipment, and apparatus.

With over 25 years of experience in designing, building, and operating test facilities and test programs, NASA/MSFC has many capabilities not available elsewhere. Structural testing of large or small flight structures can be accomplished for a variety of dynamic environments and load ranges. Development, qualification, and flight acceptance testing of parts, components, and subsystems in a wide range of aerospace environments can also be accommodated.

In support of the test facilities, NASA/MSFC has a unique manufacturing capability: it can process materials from raw stock into finished assemblies and systems. This includes machining and processing all types of metals, as well as fabrication of wood, plastic, and composite-material articles. MSFC has the capability of fabricating electrical, electronic, and electromechanical systems, subassemblies, and components.

The total capabilities of the MSFC facilities thus provide a near autonomous environment for static and dynamic testing of articles ranging in size from small parts and subsystems to complete spacecraft and launch vehicles.

A vicinity map of MSFC, showing the location of the Redstone Arsenal, and a location map of the MSFC buildings are presented in Figures 1 and 2, respectively.

The locations, specific attributes, and capabilities of test equipment, research laboratories, and test facilities available at MSFC are described in the following sections.

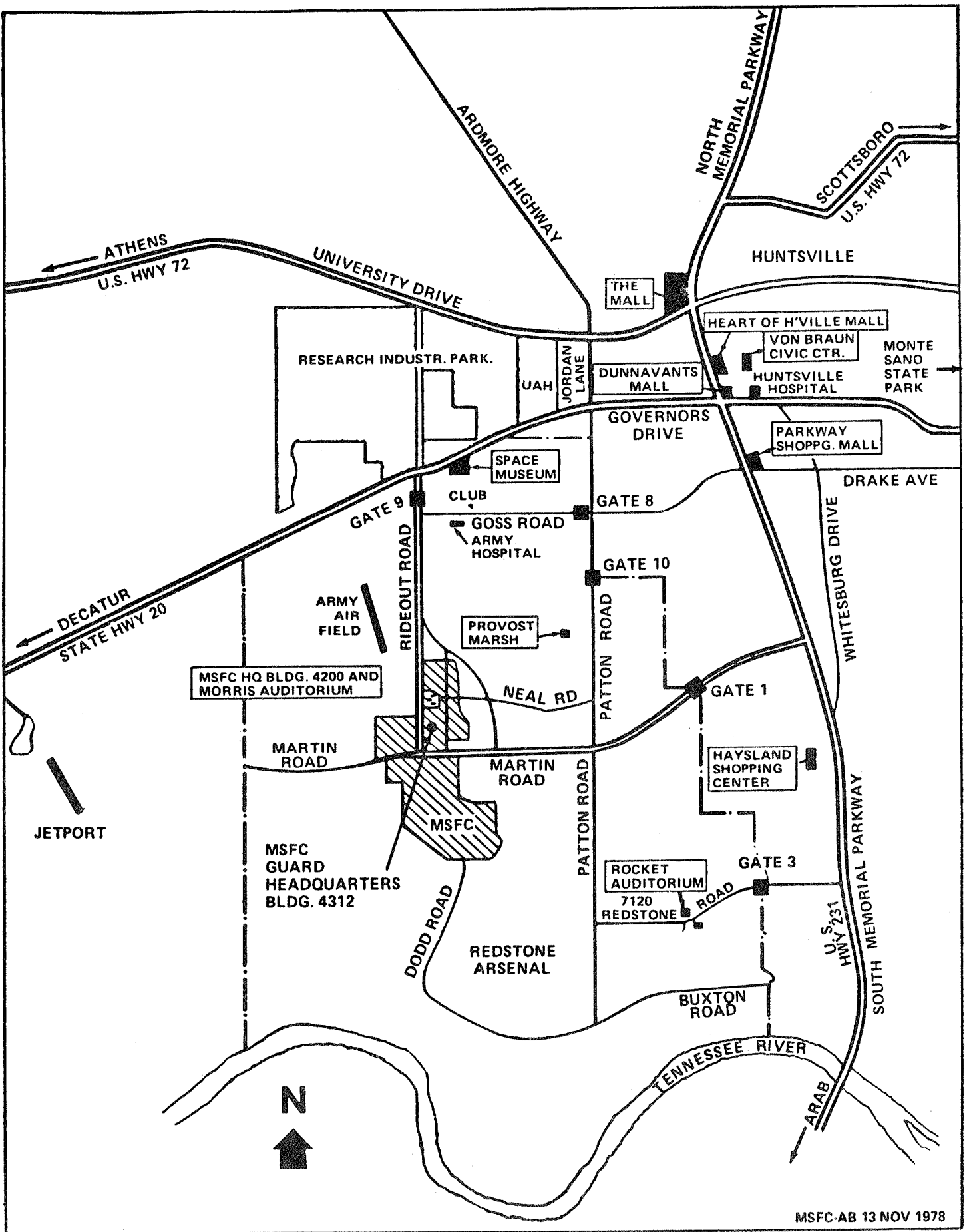

MSFC-AB 13 NOV 1978

FIGURE 1 VICINITY MAP OF MSFC, SHOWING LOCATION OF REDSTONE ARSENAL

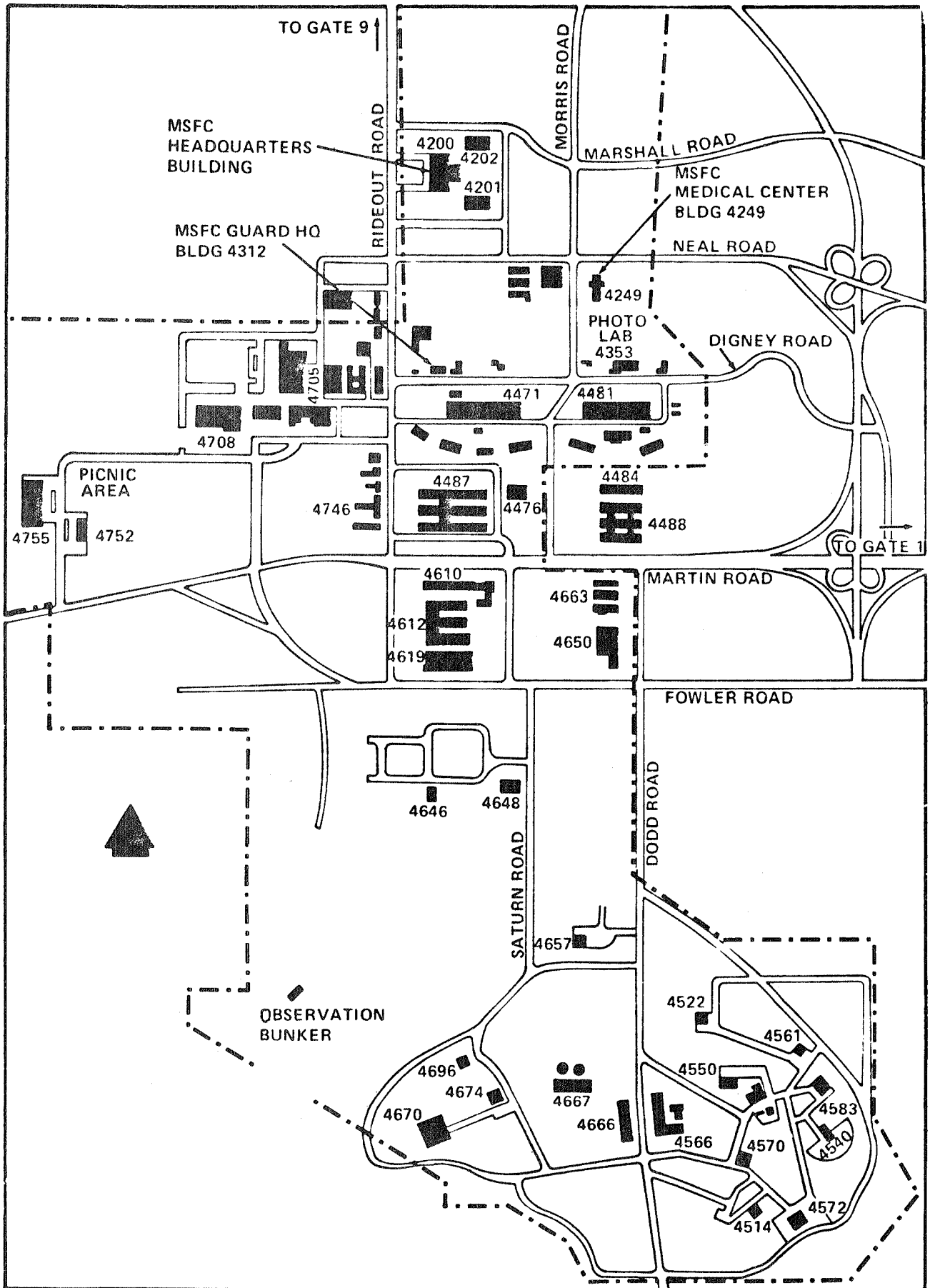

AB13 NOV 1978

FIGURE 2 LOCATION MAP OF MSFC BUILDINGS

## VIBRATION TEST EQUIPMENT

A large inventory of shakers is available at MSFC. Most of the shakers are located in Buildings 4619 and 4476. Included in the inventory are approximately 28 electrodynamic shakers and 11 hydraulic shakers, ranging in payload from 0.02 to 45 tons, that are suitable for modal testing of structural systems. However, testing with these shakers is confined to the elastic range because of their small stroke capacities, which are limited to 225 mm on four of the electrodynamically driven shakers, 150 mm on fourteen of the others, and 25 mm on the remainder.

A summary of the characteristics of the vibration equipment, including operating frequency ranges, is presented in Table 1. The following control equipment and features may be incorporated into the shaker tests:

- Three digital computers with Fourier analyzer and multipoint control.
- One computer with Fourier analyzer and capability of controlling eight shakers simultaneously.
- All systems can perform random and sine testing with automatic cutoff at preset tolerances.
- All systems can perform shock tests.

The shakers may be used to excite the following suspension systems available at NASA/MSFC:

- 18 hydraulic tables that will support 4.5 tons each
- 3 hydraulic tables that will support 15.9 tons each
- 33 air bags that will support 25.9 tons each

## HYDRAULIC ACTUATORS

Eighty-one hydraulic actuators, which can generate cyclic forces ranging from 23 to 1,000 tons, are currently located in Buildings 4618 and 4670. The stroke limits of these actuators range from  $\pm 75$  mm to  $\pm 140$  mm. The support pumps are skid mounted and are therefore easily movable, allowing flexibility of deployment of the actuators.

TABLE 1  
VIBRATION EQUIPMENT CHARACTERISTICS

Type of Shaker	Number Available	Force (tons)	Maximum Stroke (mm)	Operating Frequency Range (Hz)
Electrodynamic*	4	13.6	25	5 - 2,000
Electrodynamic*	4	9.1	225	5 - 800
Electrodynamic*	2	6.8	25	5 - 2,000
Electrodynamic*	4	3.2	25	5 - 2,000
Electrodynamic*	14	0.5	150	0 - 2,500
Hydraulic	8	22.7	25	0 - 350
Hydraulic	3	45.5	25	0 - 350

\*Shock capacity - 2,000g; spectrum - 4 - 10 kHz.

An inventory of the actuators, including a summary of their characteristics, is presented in Table 2.

#### STRUCTURES AND MECHANICS LABORATORY: BUILDING 4619

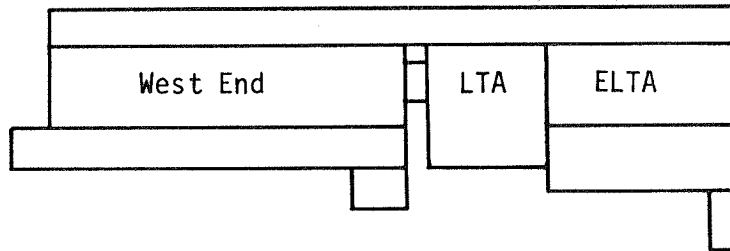

Building 4619, which houses the Structures and Mechanics Laboratory, is divided into three major portions: the west end is the original construction and was completed in 1959; the load test annex (LTA) was completed in 1963; and the extension to the load test annex (ELTA) was completed in 1965. The building portions are of permanent steel and concrete construction and provide a total area of 16,000 m<sup>2</sup>. The west end and the ELTA are basically high-bay structures with office and laboratory space located on each side. The center portion, LTA, is also a high-bay structure but has laboratory and office space on only one side. On the outside of the building, there are two large test pads (12.8 m x 12.8 m and 15.9 m x 15.9 m).

Each of the portions contains equipment and special facilities. These large areas and their supporting low-bay areas have been used for structural static and vibration load testing of both large and small components of space vehicles and payloads.

In addition, Building 4619 houses the central processor of the Structural Test and Data Acquisition System (STDAS). There are two main data acquisition areas within the building: Room 143 in the west end and Room 172 in the LTA. These systems may be linked to remote test sites by local cable systems or by the MSFC communication cable system.

The items listed below indicate the technical specifications of the three high-bay portions of Building 4619.

TABLE 2  
INVENTORY OF HYDRAULIC ACTUATORS

Number Available	Diameter (mm)	Force* (tons)	Stroke <sup>†</sup> (mm)
4	840	1,000	150
7	760	800	150
4	460	270	275
4	360	180	200
8	250	90	225
4	200	60	225
50	various	23	150 - 200

\*based on 23 MPa hydraulic pressure

<sup>†</sup>double amplitude

NOTE: Support pumps - 2 units, 910 l/min of 5606 hydraulic fluid; each system consists of four 227 l/min and can be operated as singles or any combination; currently located in Buildings 4618 and 4670.

The technical specifications of the west end include:

- Area: 22.2 m x 87.5 m
- Cranes:
  - bridge; two hooks - one 9.1-ton and one 2.7-ton; 12.8-m hook height; travel - 21.3 m x 85.4 m; Shepard-Niles
  - bridge; two hooks - one 18.2-ton and one 4.5-ton; 24.4-m hook height; travel - 21.3 m x 18.3 m; Shepard-Niles
- Access doors:
  - east end: two, 5.8 m x 6.1 m; one, 6.1 m x 6.1 m
  - west end: two, 5.8 m x 6.1 m; one, 7.3 m x 7.3 m
- Pressure test cell: 5.5 m x 17 m x 3.7 m
- Test bed:
  - 15.2 m x 22.3 m x 1.5 m; 32 anchor points
  - 15.2 m x 18.3 m x 0.6 m; 12 anchor points

The technical specifications of the LTA include:

- Test-bay area: 51.5 m x 49 m x 47.3 m high
- Crane: bridge; two trolleys; two hooks - 13.6 tons each; hook height variable to 32.3 m
- Static load test machine: 13,600-ton test capacity; specimen size - up to 35 m x 19.8 m
- Numerous tie points to crosshead and concrete test pad below
- Access door: 18.3 m x 22.9 m

The technical specifications of the ELTA include:

- Test-bay area: 29 m x 61.9 m x 29.6 m high
- Crane: bridge; two hooks - one 18.2-ton and one 4.5-ton; 24.4-m hook height
- Test bed: 48.8 m x 21.3 m x 3.4 m; 106 load plates 3 m on center, each plate load capacity
- Access door: 12.2 m x 12.2 m
- Trench and conduit system provided for control and instrumentation



The test floor of the ELTA is a high-force floor having tiedown pads located on 50-mm tiedowns on 450-mm centers. Each tiedown pad has a 225-ton vertical capacity and 225-ton shear capacity. Located on the northwest corner of the test floor is a 1,360-ton universal testing machine (tension or compression) capable of applying a cyclic load of  $\pm 450$  tons. It has both load rate and strain rate controls and will accommodate specimens up to 3 m in diameter and 7.6 m high. Adjacent to the high bay are rooms used for instrumentation and test control.

The tensile test room, Room 102A of the ELTA, contains three universal testing machines: a 22.5-ton BLH, a 90-ton Tinius Olsen, and a 180-ton Riehle. These machines are capable of applying uniaxial loading only. The technical specifications for these three machines are as follows:

- 22.5-ton BLH:
  - 0.53-m-wide opening
  - 0.5-m x 0.5-m lower load table
  - 0.89-m tension space
  - 0.84-m compression space
  - 200-mm stroke
  - loading speed range - 0.20- to 244-mm/min auto-matic cyclic capability
  - four load ranges (0.45, 1.14, 4.5, and 22.5 tons)
  - screw gear mechanical drive
- 90-ton Tinius Olsen:
  - 0.76-m-wide opening
  - 1.88-m tension space
  - 1.88-m compression
  - 300-mm stroke
  - three load ranges (9, 45, and 90 tons)
  - hydraulically actuated
- 180-ton Riehle:
  - 0.9-m-wide opening
  - 2.7-m tension space
  - 2.7-m compression space
  - 300-mm stroke
  - six load ranges (1.8, 9, 18, 36, 90, and 180 tons)
  - hydraulically actuated

## STRUCTURAL TEST TOWER: BUILDING 4619

A 43-m-tall structural test tower (strong back) is located in the LTA of Building 4619. The test tower has the capacity to apply a load of 1,090 tons horizontally to test structures that range in height from 12.2 m to 35 m and have a maximum plan dimension of 24.4 m x 15.2 m (assembled under the tower). The structure test stand is composed of a movable vertical load reaction head between four tower legs, all made of ASTM A-36 steel (Figure 3). The head is situated over a thick steel-reinforced concrete floor (Figure 4) with floor tiedowns on 457-mm centers, as shown in Figure 3. Five horizontal box plate girders spanning two of the tower legs at 6.1-m intervals up to a height of 30.5 m provide load reaction for bilateral horizontal loads applied to the test specimen in conjunction with specially designed lateral-reaction test fixtures. The tower legs are embedded in concrete down to bedrock, at a depth of over 7.9 m below the finished floor. The tower foundations are tied together with 2.3-m x 7.9-m-deep reinforced concrete beams to eliminate up-lift anchors for the test stand. Figures 5a and 5b illustrate the horizontal and vertical loading configurations of the test tower, respectively.

The vertical load reaction head position is adjusted by using four "roll ramps" that travel on four stationary, 350-mm-diameter double acme threaded stems. These stems run almost the full height of the towers and support in tension the total suspended weight of the crosshead during moving operations. After positioning the crosshead at the desired level, it is bolted to the columns of the tower legs to serve as a strong back for the vertical loads.

The structural test tower was designed to provide the load reaction required for the structural testing of components, subassemblies, and assemblies of large space structures. This application is illustrated in Figure 6. Biaxial lateral loads have been applied to large space structures via loading beams that were attached to special-purpose steel-frame test fixtures enclosing the test specimen and that were anchored at the floor and the crosshead. The loading beams may be jacked in two perpendicular horizontal directions simultaneously.

The structural test tower load capacity provides a unique facility for destructive static-cyclic testing of full-scale structures up to ten stories in height.

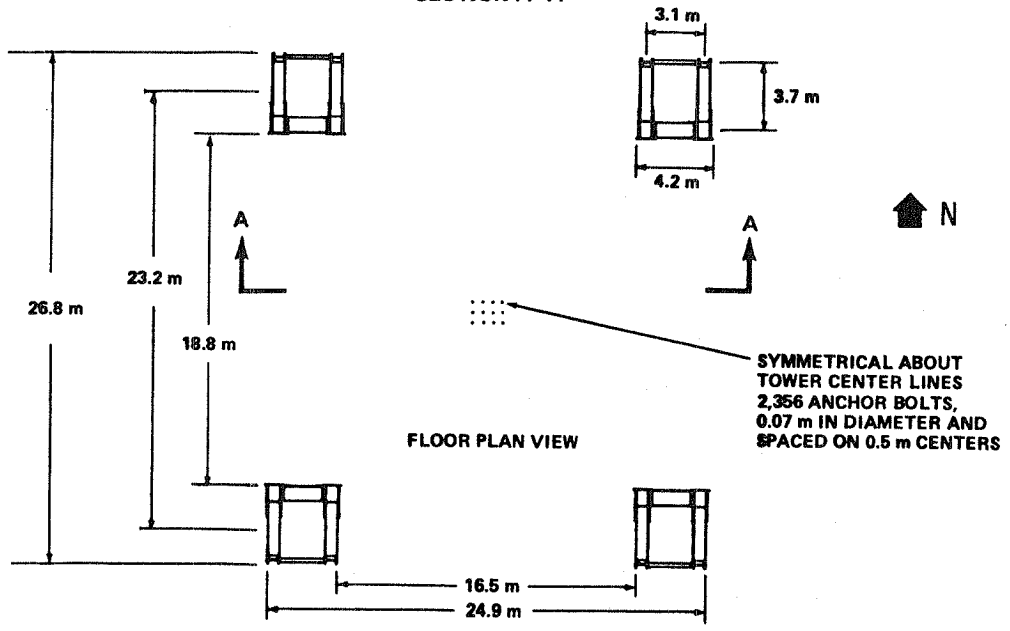
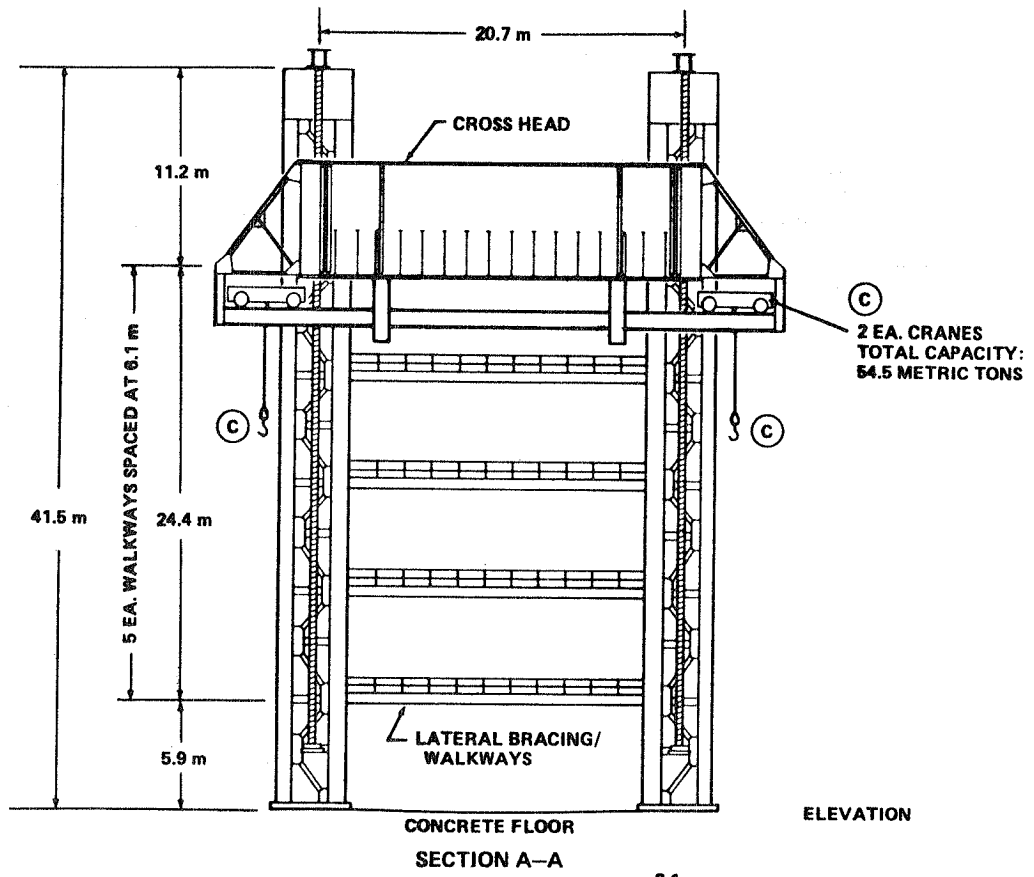

FIGURE 3 STRUCTURAL TEST TOWER

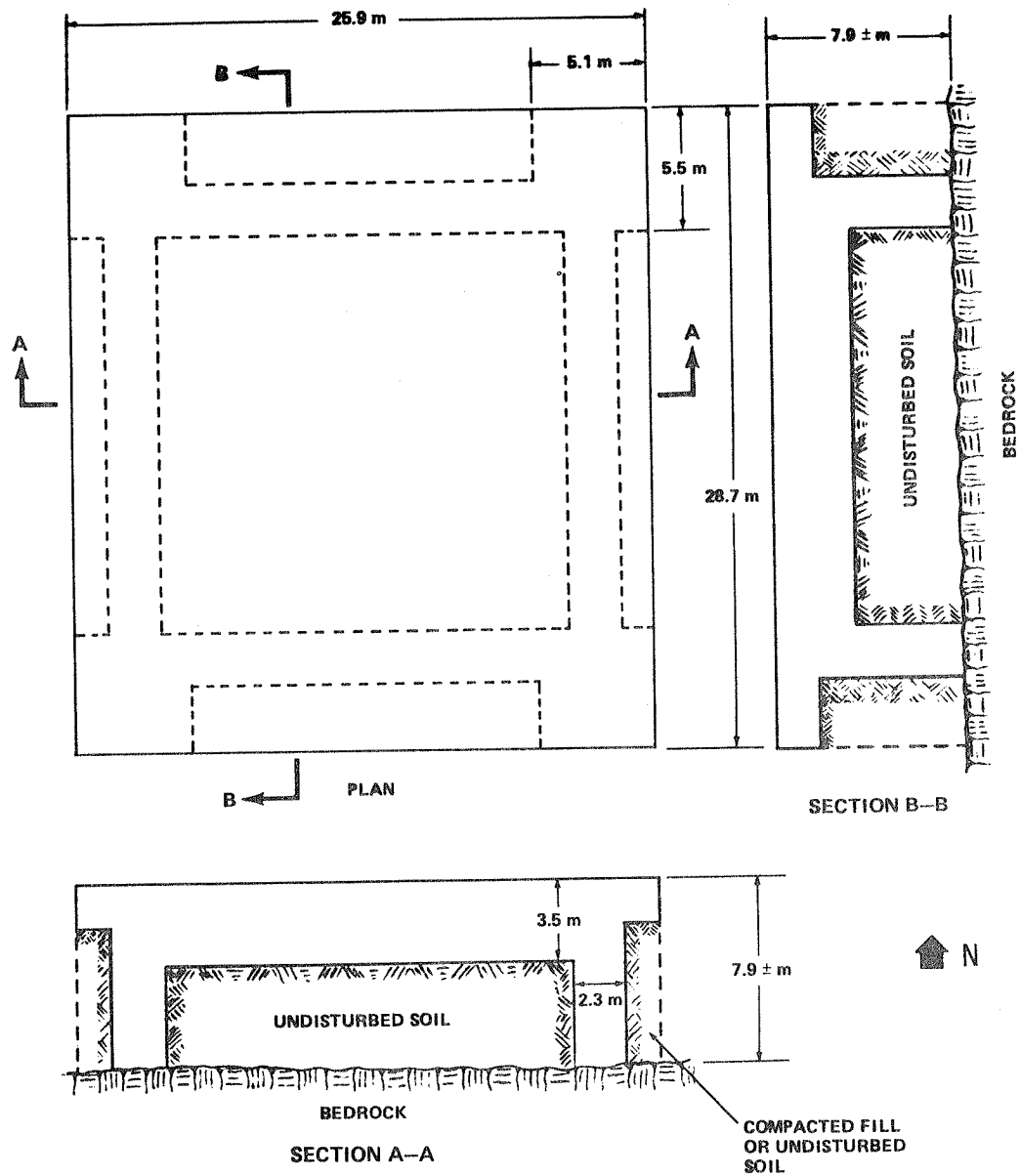
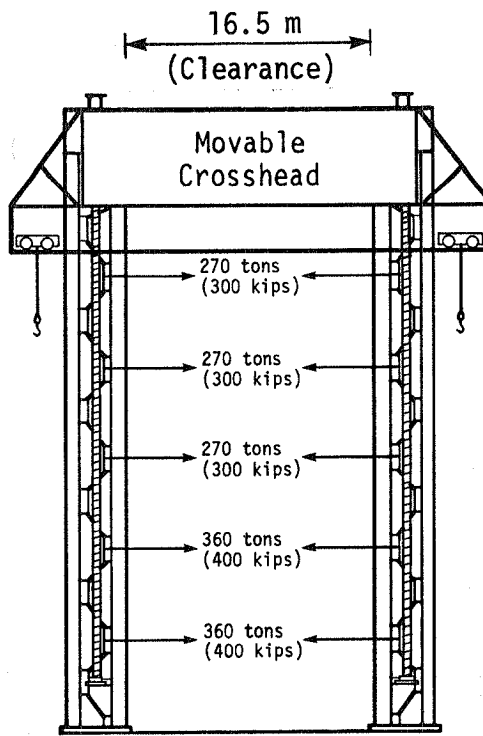
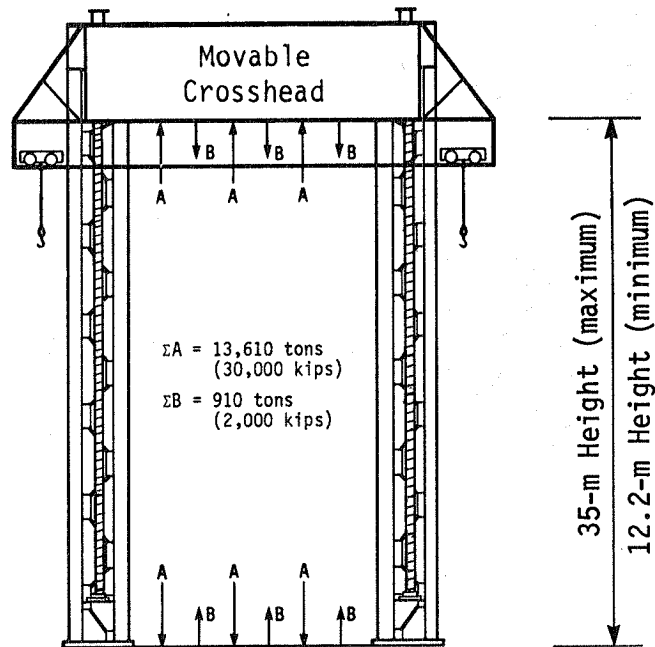

FIGURE 4 STRUCTURAL TEST TOWER FOUNDATION



a. Horizontal Load Diagram



b. Vertical Load Diagram

FIGURE 5 STRUCTURAL TEST TOWER LOAD CAPACITY

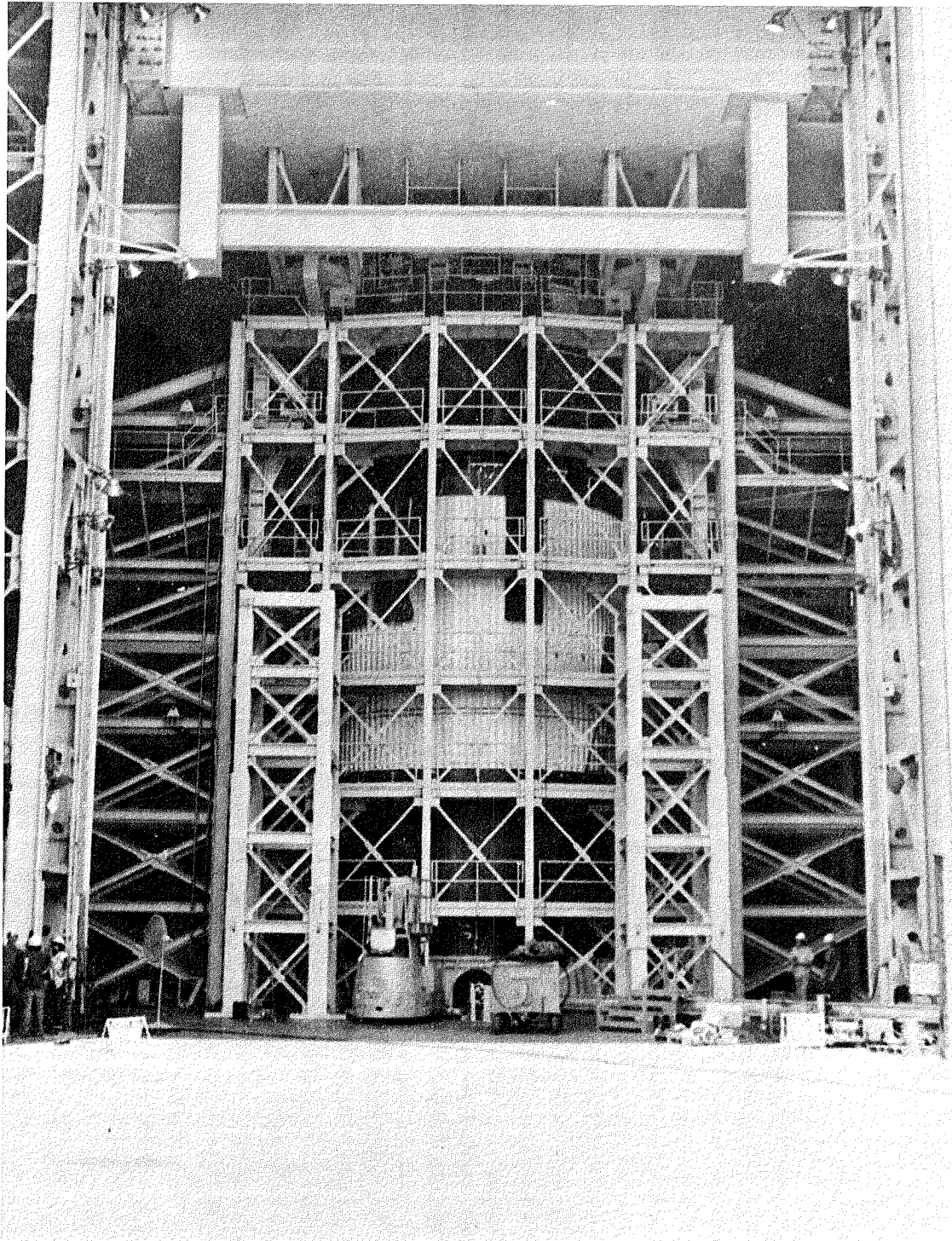

FIGURE 6 STRUCTURAL TEST TOWER WITH TEST SPECIMEN  
AND LOAD REACTION TEST FIXTURE

## MODAL SPECIAL TEST EQUIPMENT: BUILDING 4619

The modal special test equipment (modal STE) is located in the ELTA of Building 4619. It was designed to perform modal vibration tests, with three-dimensional excitation, on the liquid oxygen tank of the Space Shuttle. Figure 7 shows an overall view of the modal STE.

For these tests, 14 shakers were attached to the liquid oxygen tank. The shakers were operated from a central system able to accurately control phase differences between the motion of 8 of the shakers simultaneously. An enclosure cage provided support to the shakers via air bags (which act as dynamic insulators).

The enclosure cage for servicing the test specimen has a height of 24 m and encloses a cylindrical area 15.9 m in diameter. It has a cant capability of up to 13°, allowing simulation of the Space Shuttle takeoff configuration (see Figure 8).

The system of air bags (see Figure 9), which was designed to support the base of the test specimen, allows a free-free boundary condition of the specimen to be simulated. The air bag support system has a vertical suspension frequency range of 0.7 to 5 Hz and a horizontal suspension frequency range of 0.2 to 1 Hz. The horizontal and vertical displacement range is  $\pm 37$  mm. The displacement range may be increased to  $\pm 125$  mm by using a different type of air bag.

The technical specifications of the modal STE are as follows:

- Enclosure case (access structure):
  - provides complete 360° access to structural test assembly with base diameter of 8.5 m
  - overall height of 24 m
  - 15.9 m x 15.9 m at midheight
  - cant capability of 13° or intermediate angles
- Air bag support system:
  - 33 Model 321 Firestone air bags
  - maximum load at 0.93 MPa of 864 tons

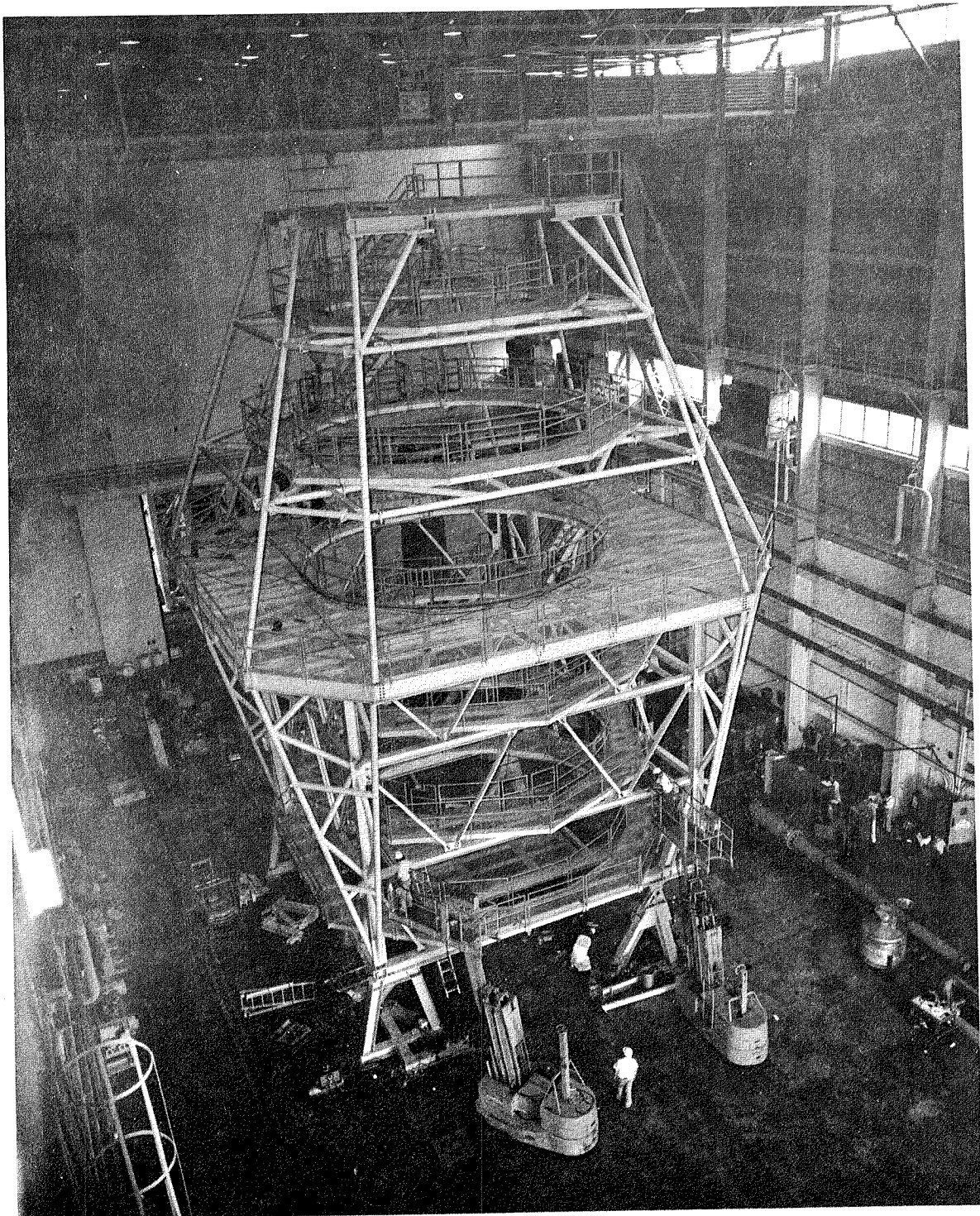

FIGURE 7 OVERALL VIEW OF MODAL STE



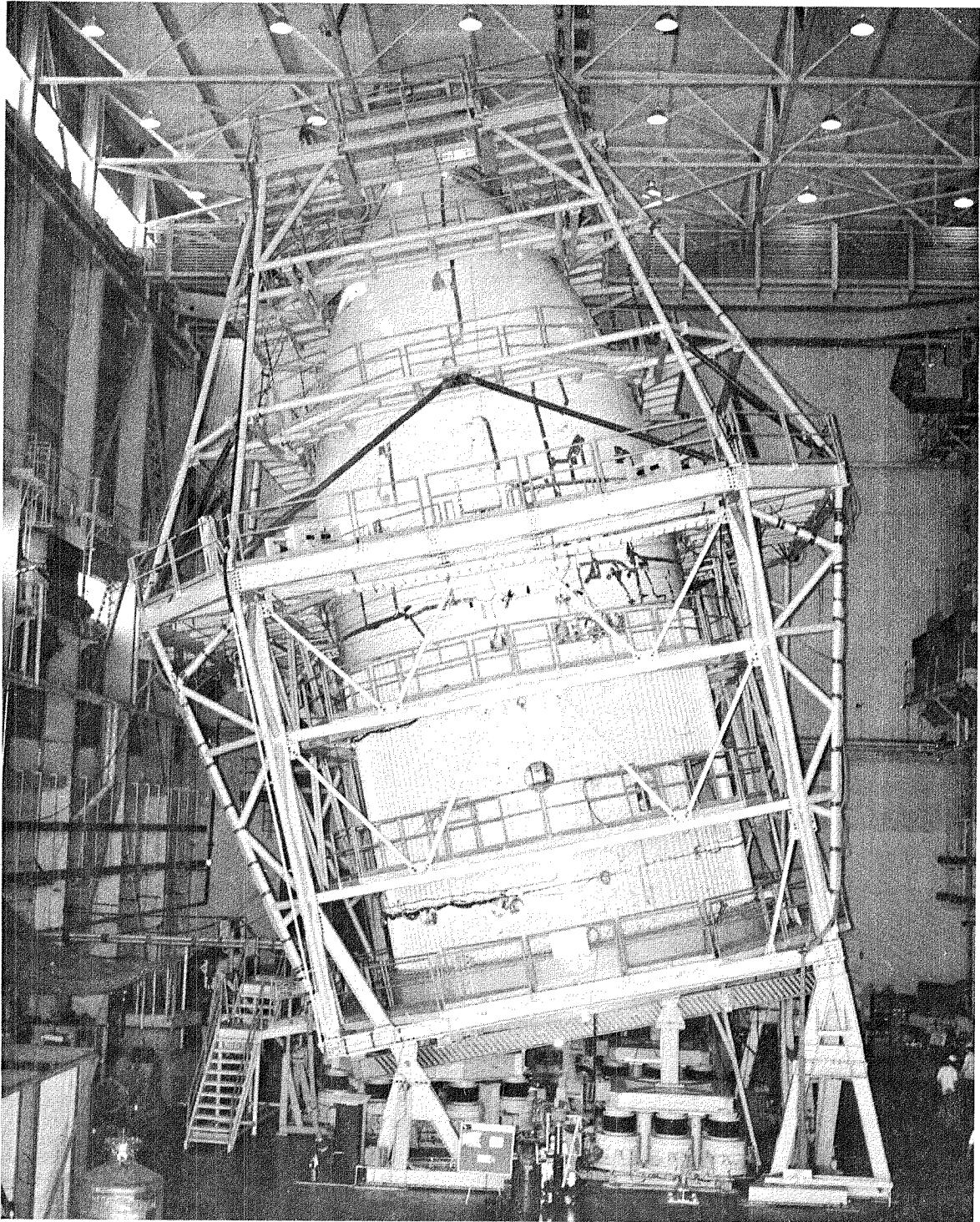

FIGURE 8 MODAL STE WITH TEST SPECIMEN

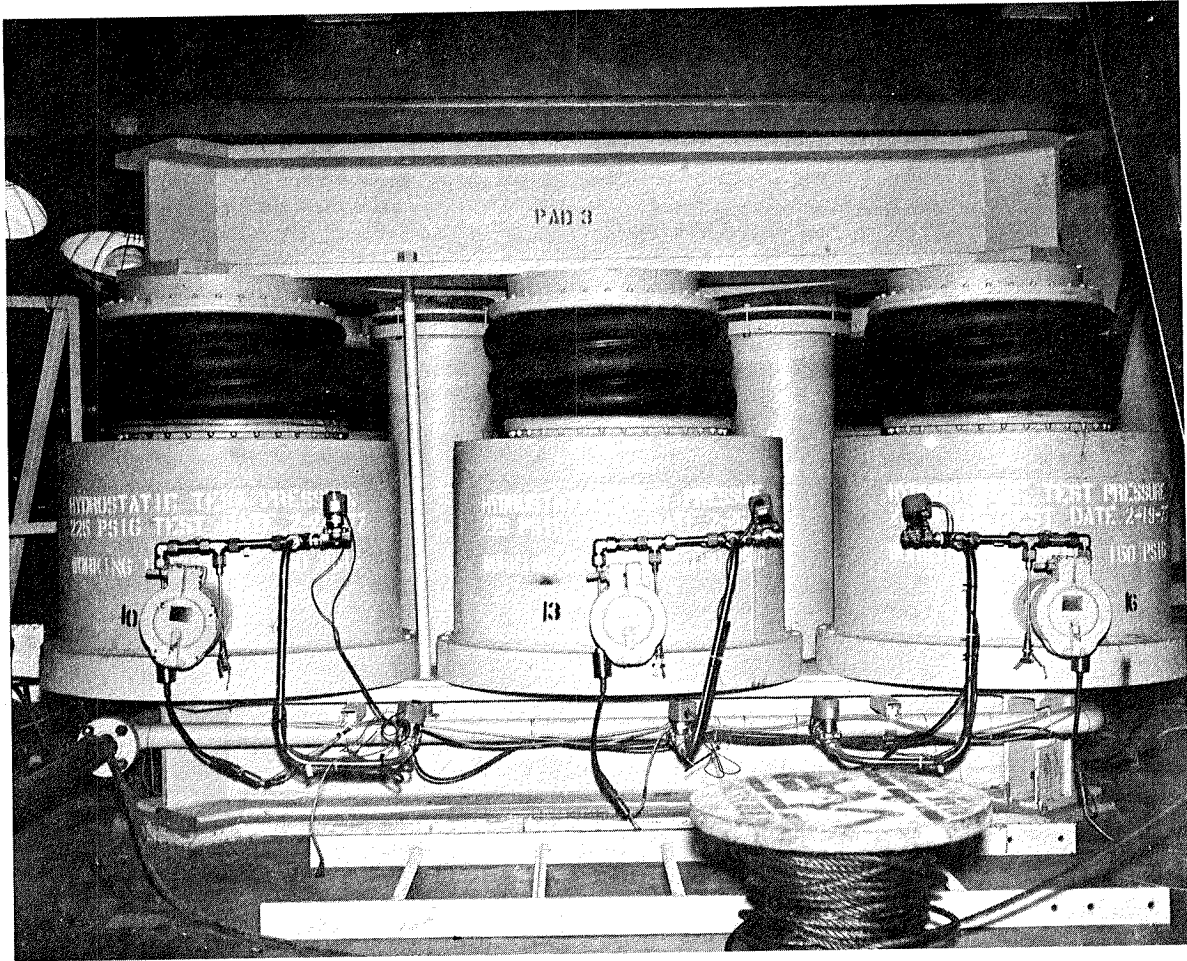

FIGURE 9 AIR BAG SUPPORT SYSTEM FOR MODAL STE

- vertical suspension frequency range 0.7 to 5 Hz
- horizontal suspension frequency range 0.2 to 1 Hz
- test range displacement  $\pm 37$  mm
- horizontal test range displacement  $\pm 13$  mm without lateral stabilizers,  $\pm 37$  mm with lateral stabilizers
- three-dimensional excitation feasible
- Air supply system: maximum flowrate of  $42.5 \text{ m}^3/\text{min}$
- Pressure, purge, and vent system:
  - maximum flowrate of  $19 \text{ m}^3/\text{min}$
  - 0 to 21 MPa capability
- Fluid fill and drain system:
  - 780,000-l storage
  - 1,500-l/min pump rate
  - homogenous fluids to 2.2 specific gravity

#### S-1C STATIC TEST STAND: BUILDING 4670

The S-1C static test stand is designed for vertical load testing; it stands 124 m tall, including the derrick boom. The superstructure is 81.4 m high. External views of the facility are shown in Figures 10 and 11.

The test stand was used during the Saturn-Apollo Program to anchor the Stage I of the Saturn V Rocket while its jets were fired experimentally during thrust-load tests of the spacecraft. The test stand essentially consists of four concrete piers, each measuring  $14.6 \text{ m}^2$  at the base and tapered to  $3 \text{ m}^2$  at an elevation of 61 m. At this elevation, the concrete piers are tied together with 6-m-deep structural-steel load platforms.

The face-to-face spacing of the piers is 18.6 m. Figure 11 shows a close-up view of the test stand.

The foundation is keyed into bedrock approximately 14 m below grade. With modifications, the stand can accommodate a test specimen 52 m long and 12 m in diameter and load it with a vertical thrust force of up to 5,450 tons. During the Saturn V testing, a horizontal force equal to 5% of the vertical thrust was applied to the test stand due to inclination of the line of thrust. The facility is therefore capable of reacting substantial horizontal loads.

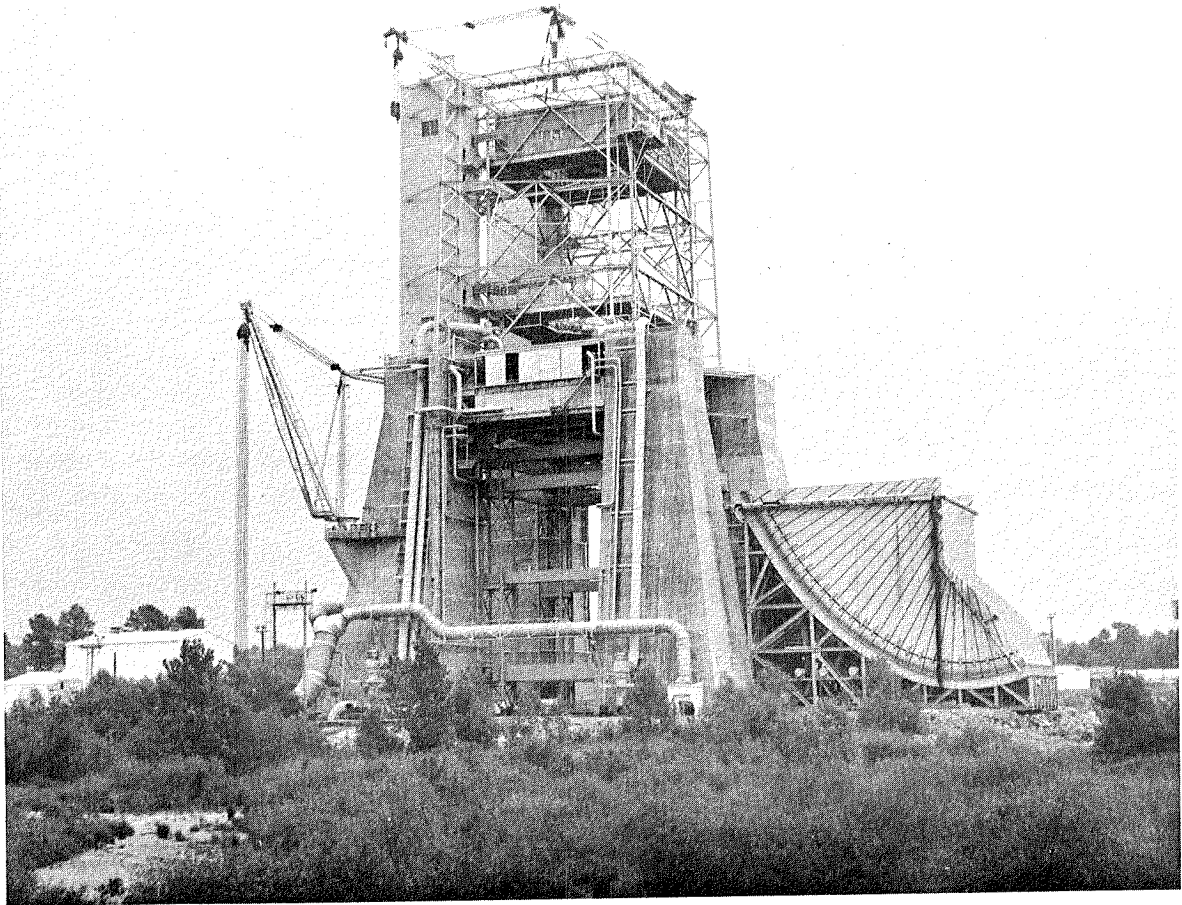

FIGURE 10 OVERALL VIEW OF THE S-1C STATIC TEST STAND

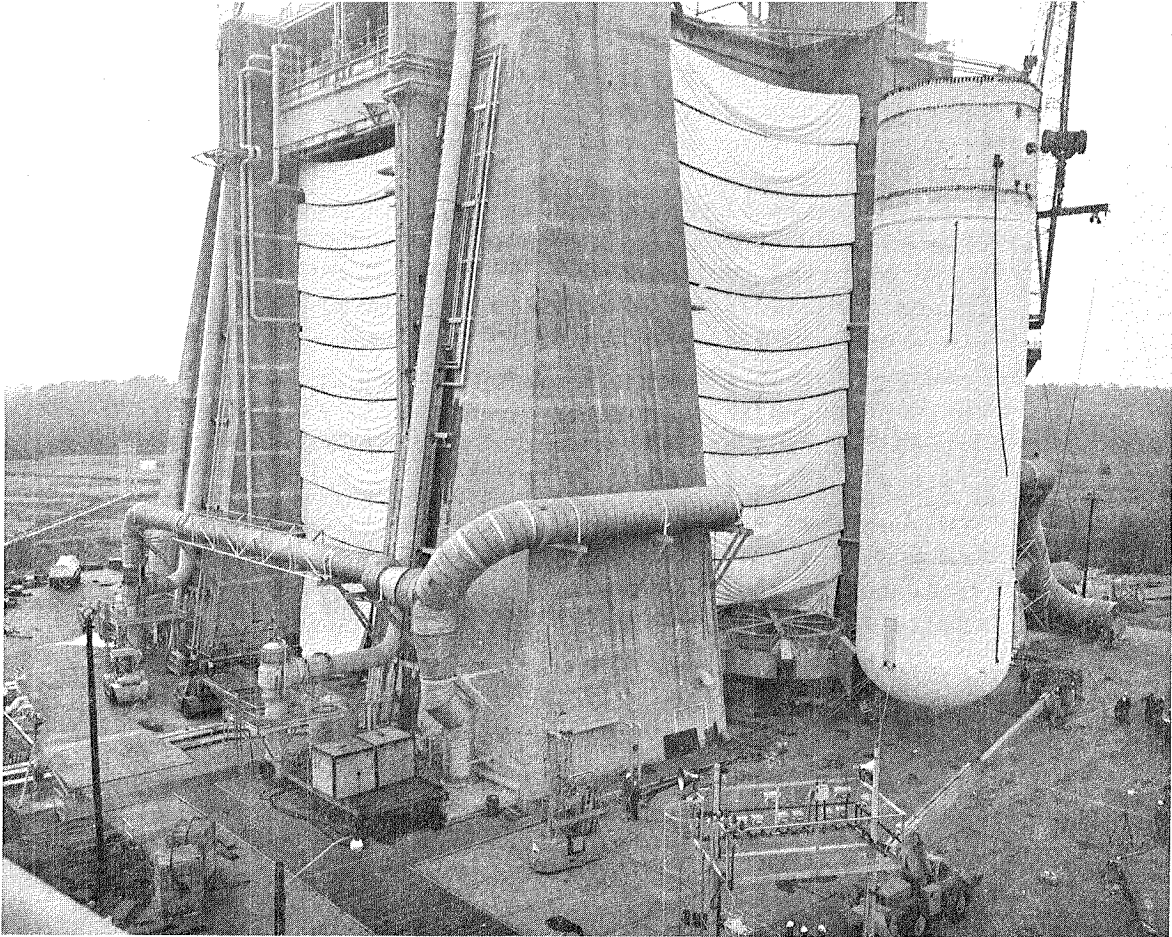

FIGURE 11 CLOSE-UP VIEW OF THE S-1C STATIC TEST STAND



All control and instrumentation requirements are provided by the West Area Blockhouse. Analog tape units, digital systems, oscillograph recorders, and strip charts are available. The facility has communication and data processing links with the STDAS in Building 4619.

The technical specifications for the S-1C static test stand are as follows:

- Superstructure height: 81.4 m
- Handling equipment: 182-ton overhead derrick;  
150-ton lower derrick
- Industrial water: 26,600,000-l storage capacity  
(two 13,300,000-l reservoirs)
- LH<sub>2</sub> storage: 2,850,000 l
- GHe system: 110-m<sup>3</sup> (H<sub>2</sub>O volume) storage battery at  
base of stand that supplies 35 MPa He pressure to  
stand through 75-mm line; storage battery connects  
to area high-pressure GHe system
- Air supply: 2-m<sup>3</sup> (H<sub>2</sub>O volume) storage battery at  
base of stand that supplies 25 MPa air pressure to  
stand; storage battery connects to area high-pres-  
sure air system
- GH<sub>2</sub> system: 350-m<sup>3</sup> (H<sub>2</sub>O volume) storage battery  
that will supply 21 MPa GH<sub>2</sub> pressure to the LH<sub>2</sub>  
storage and test stand areas; storage battery con-  
nects to area high-pressure GH<sub>2</sub> system
- Hydraulic system: 1,400 l/min at 21 MPa
- Total instrumentation: channels - 6,000; served by  
West Area Blockhouse and Building 4619 data acquisi-  
tion center

#### VERTICAL GROUND VIBRATION TEST FACILITY: BUILDING 4550

Building 4550 stands 110 m tall and encloses a 22.5-m x 22.5-m test-bay area. Figure 12 shows an overall view of Building 4550. The Space Transportation System was tested in two test configurations. In the first, the Orbiter and the External Tank were suspended from cables within this building to model the free-free boundary condition during testing. The "mated" system was excited dynamically, and the modes of vibration and center of gravity of the structure were measured. In the second configuration, the system, consisting of the "mated" Orbiter-External Tank and two Solid Rocket Boosters (SRB), was supported at the SRB aft launch-pad attach points by hydrodynamic sup-

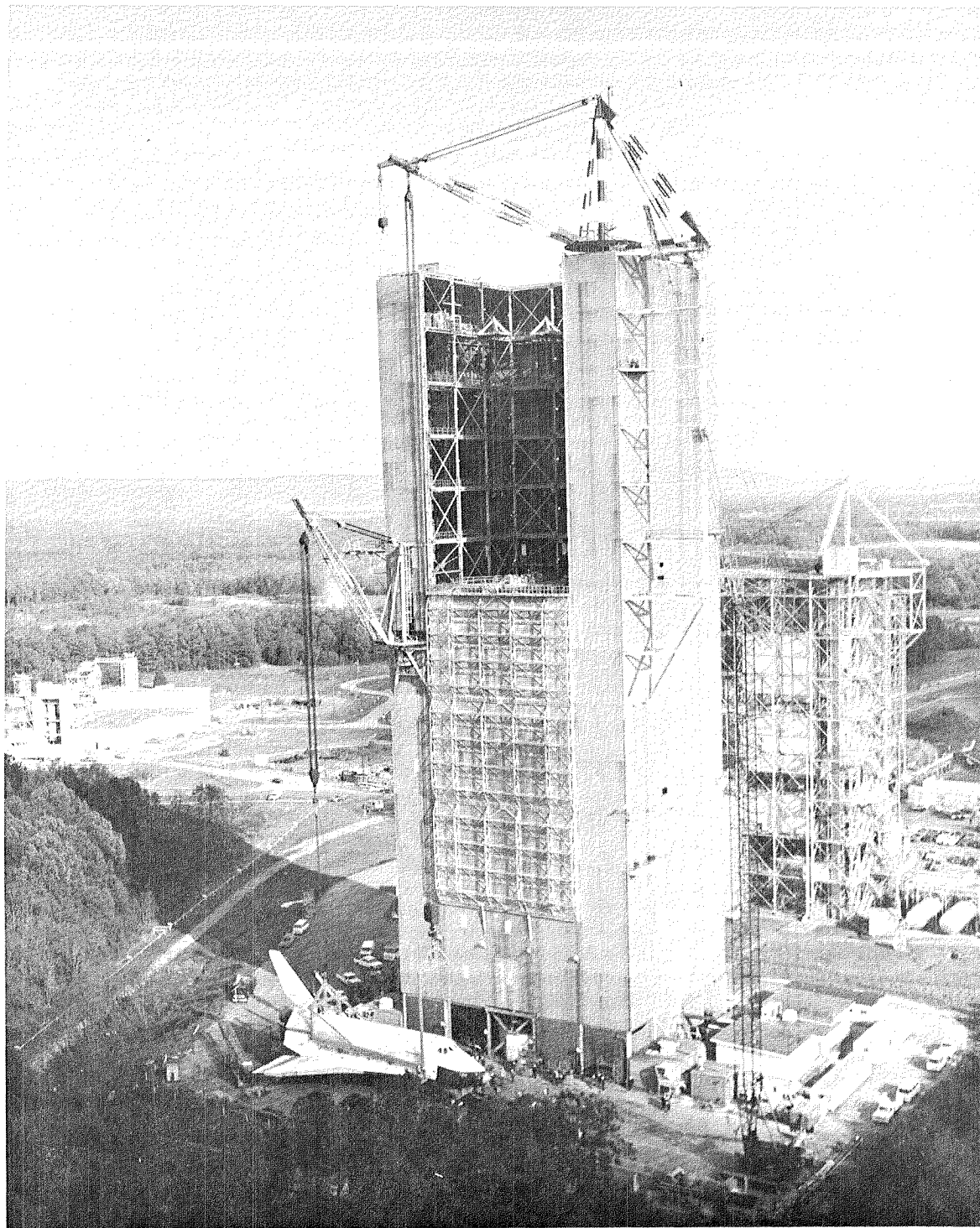

FIGURE 12 VERTICAL GROUND VIBRATION TEST FACILITY:  
OVERALL VIEW OF BUILDING 4550

ports and was subjected to a six-degree-of-freedom dynamic test program. Figure 13 shows a view of this second test configuration. A removable roof (22.5 m x 22.5 m in area) and two mounted derricks with 182-ton and 159-ton capacities were designed to facilitate maneuvering of massive test specimens to and from the building.

The foundation consists of a 2.4-m-thick reinforced concrete mat with a load capacity of 5,450 tons.

The technical specifications for the vertical ground vibration test facility (Building 4550) are as follows:

- Building:
  - outside dimensions - 30 m x 37 m x 110 m high
  - test bay areas - 22.5 m x 22.5 m
  - support offices - 7.3-m perimeter bays
  - personnel elevator and stairway - south side
  - mounted derricks - 182 tons, top; 159 tons, north side
  - removable roof - 22.5 m x 22.5 m
  - test article access door - 22.5 m x 44 m
  - vehicle access door - 7.3 m x 7.3 m
  - foundation load capability - 5,450 tons
  - hydrodynamic supports (six degrees of freedom for test article support) - 909-ton limit per support and 3,640-ton limit total
- Utilities:
  - electric service - 1,250 kVA
  - industrial pressurants - 35-MPa nitrogen and 24.5-MPa missile-grade air
  - industrial water - 0.56 MPa
  - deionized water - storage and transfer pump
  - shop air - 0.77 MPa
  - breathing air ducting - 20-ton A/C



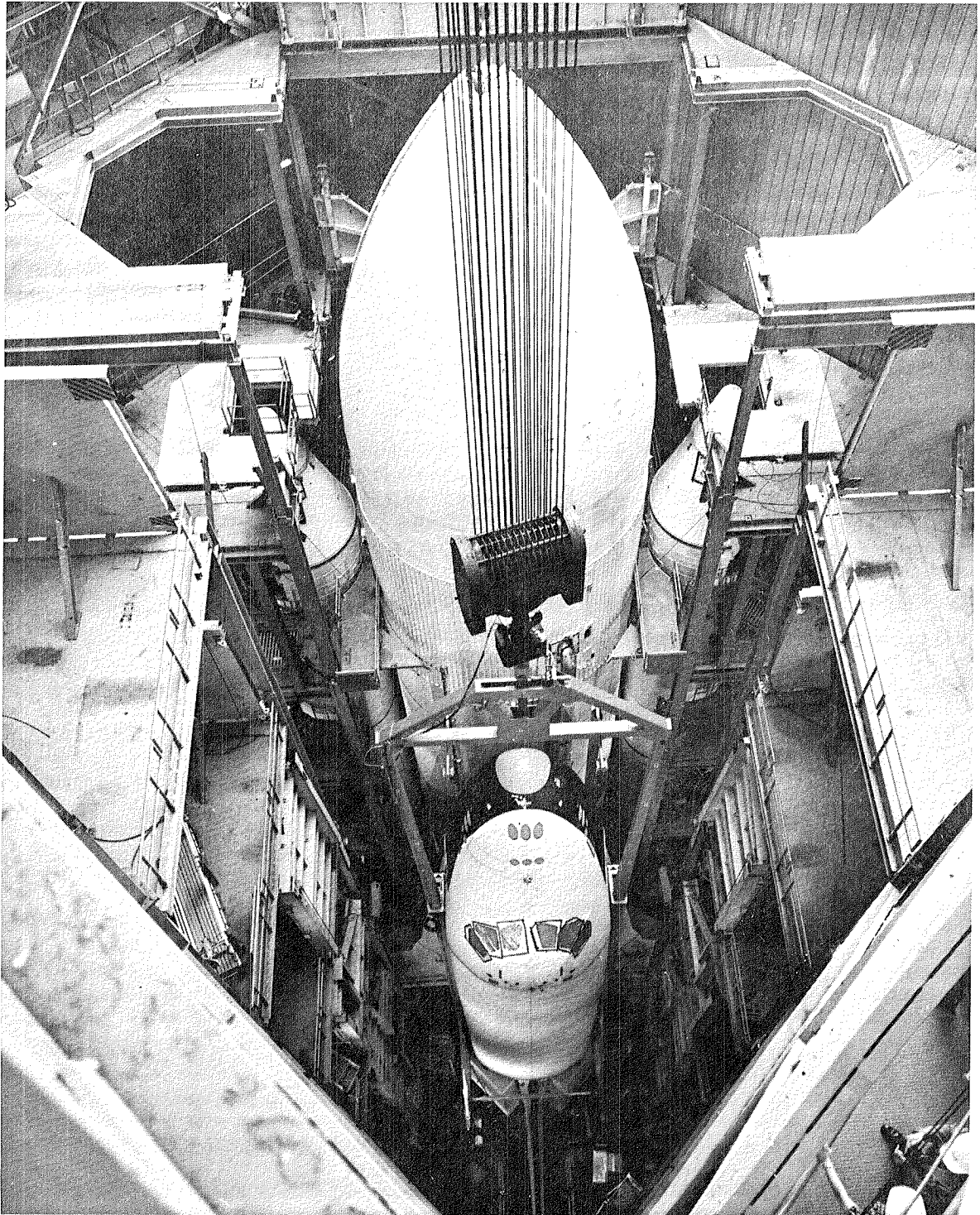

FIGURE 13 VERTICAL GROUND VIBRATION TEST FACILITY: INTERIOR VIEW OF BUILDING 4550 SHOWING SPACE TRANSPORTATION SYSTEM (SPACE SHUTTLE ORBITER, EXTERNAL TANK, AND TWO SOLID ROCKET BOOSTERS)

- Instrumentation and control (Building 4551 terminal):
    - digital recording
    - analog recording
    - oscillographs
    - event recorder
    - TV and motion picture controls
- } 600 channels

**STRUCTURAL TEST FACILITY FOR HAZARDOUS TESTS:  
BUILDING 4572**

The structural test building was specially designed and built for structural testing of the Solid Rocket Booster "Short Stack" Structural Test Article. The test building provides a load reaction structure capable of reacting multidirectional loads of up to 1,270 tons through the end walls and floor-embedded beams. The test building is equipped with a 9.1-ton bridge crane (two 4.5-ton hooks) and is serviced by a 41-ton gantry crane outside the building. The building has a six-panel removable roof for test article and test equipment insertion. An aerial view of Building 4572 with the roof removed is shown in Figure 14.

The annex building, which is located adjacent to the structural test building, provides for remote test control. It contains control, instrumentation, and pump rooms, as well as power distribution (4,160 kVA), office, and shop areas. The annex has a large-volume liquid storage capability for large hydrostatic tests.

The structural test building has the following technical specifications:

- Size:
  - building - 14.8 m x 46.3 m x 11 m high
  - clear test area - 12.5 m x 28.7 m x 9.8 m high
- Load reaction:
  - west wall - 3.6 m x 12.2 m x 8.8 m high, reinforced concrete with embedded girders
  - east wall - 2.1 m x 12.2 m x 8.7 m high, reinforced concrete with embedded steel load ring
  - floor - 1.5-m-thick reinforced concrete with WF10-60 to WF10-112 embedded beams

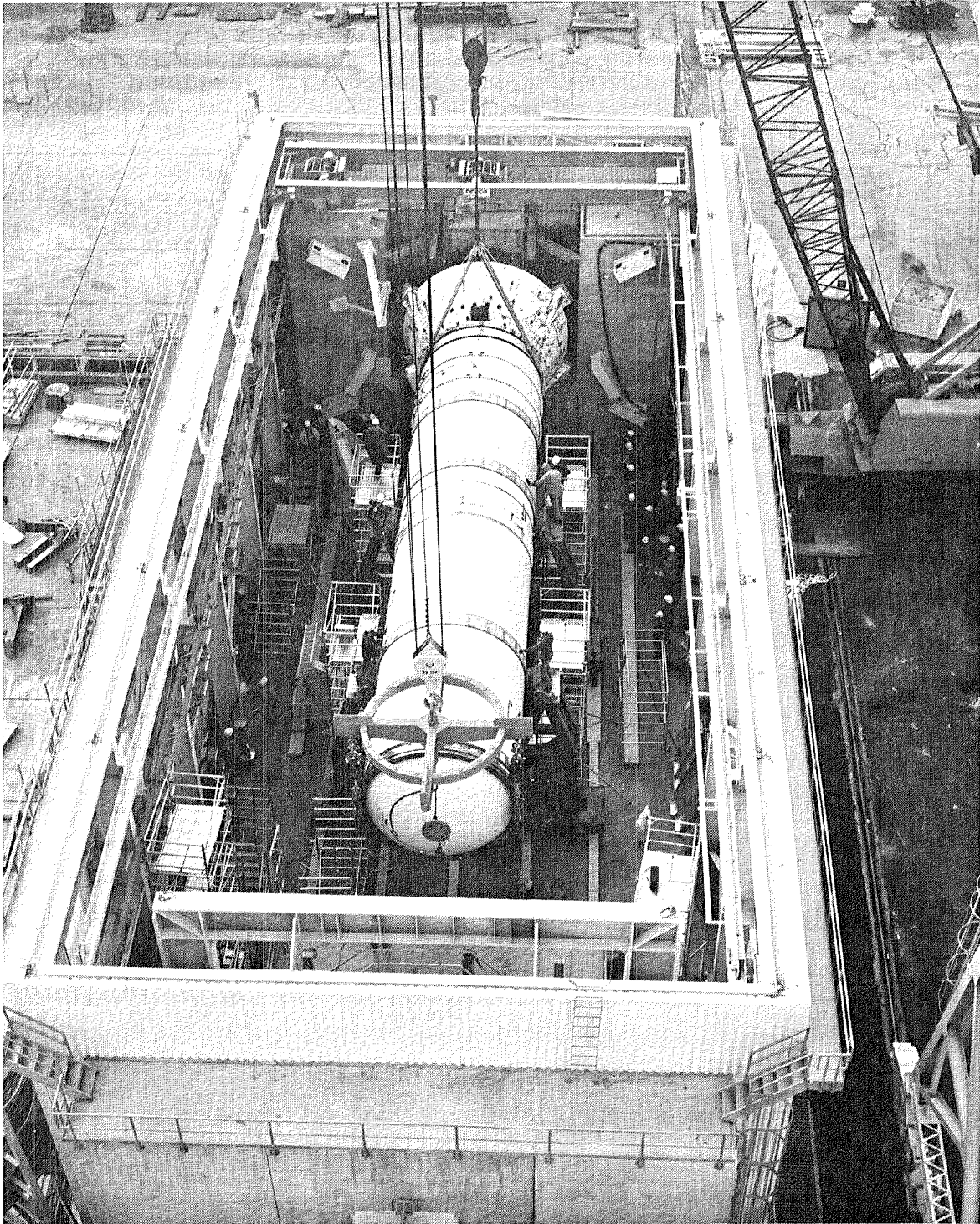

FIGURE 14 STRUCTURAL TEST FACILITY FOR HAZARDOUS TESTS: AERIAL VIEW OF BUILDING 4572 WITH ROOF REMOVED

-- test floor tiedown - WF10-60 to WF10-112 embedded beams

The technical specifications for the annex building are as follows:

- Instrumentation: STDAS
- High-pressure water: 1.4 MPa through 1,200-mm and 400-mm lines
- Liquid storage: 260,000 l, with oil pumps

#### NEUTRAL BUOYANCY SPACE SIMULATOR: BUILDING 4706

The neutral buoyancy space simulator is unique because of its size and support systems. A large water tank, 22.9 m in diameter and 12.2 m deep, is the heart of the simulator. The tank is supported on a floating slab foundation. Integrated into this tank are special systems for underwater audio and video links, pressure-suit environmental control, and emergency rescue and treatment. These systems provide life support for up to four pressure-suited subjects simultaneously. Figure 15 shows a cutaway view of the neutral buoyancy space simulator.

Weights or floats may be added to immersed objects to neutralize their buoyancy in the tank environment. In this way a zero-gravity condition is achieved relative to other objects in the simulator.

Additional systems include data acquisition and recording; underwater lighting; special underwater pneumatic and electrical power operations of motor, valves, controls, and indicators that are required for high fidelity; and functional engineering mock-ups and trainers.

A newly constructed and completely equipped test control center is used for directing, controlling, and monitoring the simulation activities. A trailer annex contains the operating crew dressing and shop area; however, a new building is currently under construction to house these facilities. Building 4705 contains fabrication and maintenance areas for electronic systems, mock-ups, and mechanical systems.

# NEUTRAL BUOYANCY SIMULATOR COMPLEX

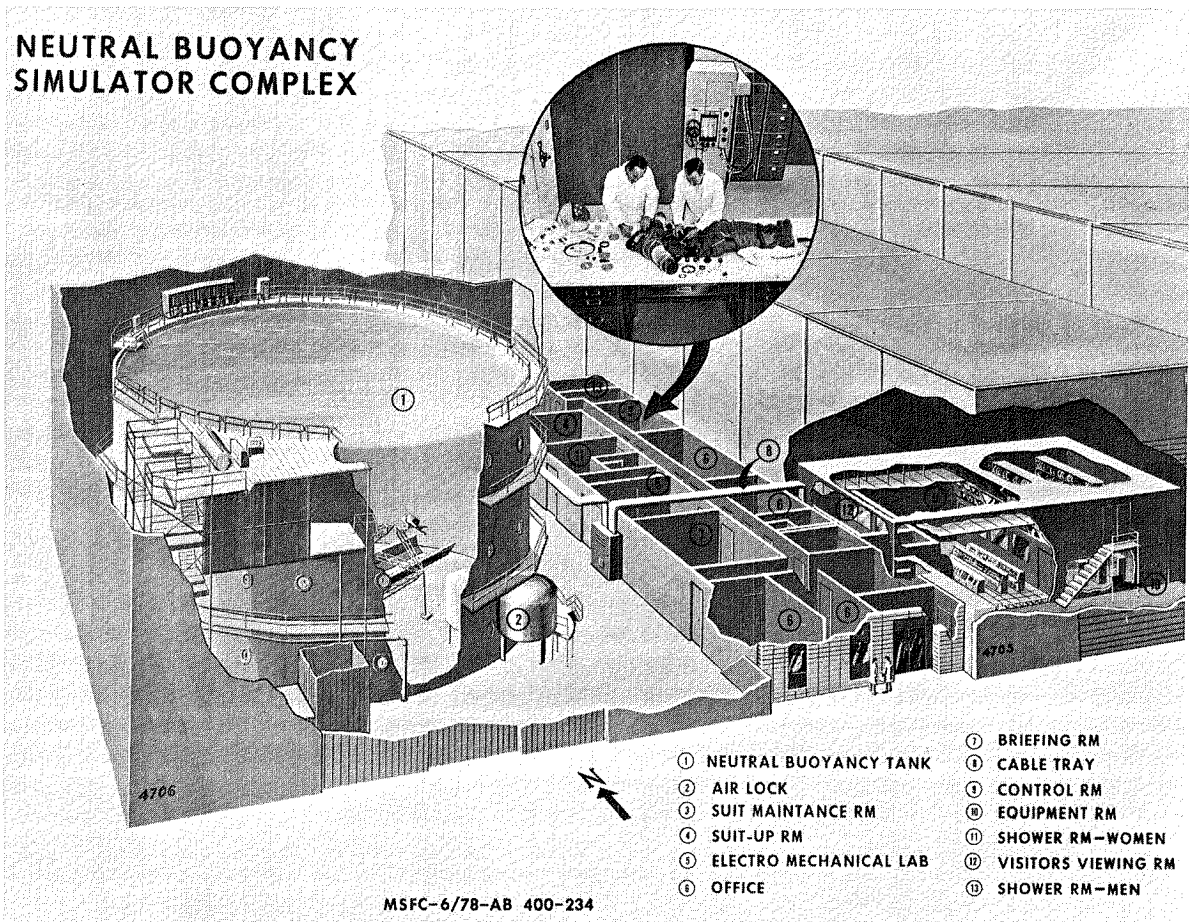

FIGURE 15 CUTAWAY VIEW OF NEUTRAL BUOYANCY SPACE SIMULATOR



The neutral buoyancy space simulator could be used as a facility to study dynamic fluid-structure interaction and soil-fluid-structure interaction. Reduced-scale models of offshore structures, including their foundations, could be installed within the large water tank. By mounting the available shakers on the structure, the systems could be excited dynamically, and the interactive response of the surrounding water, the foundation, and the structure could be measured.

This testing program is made feasible by the availability of the large water tank, the shakers, and the control and data acquisition systems that have been designed to function under water.

The technical specifications for the neutral buoyancy space simulator are as follows:

- Size:
  - diameter - 22.9 m
  - depth - 12.2 m
  - number of subjects that can be tested - 4
- Equipment handling:
  - 1-ton overhead hoist with 3.7-m hook height
  - 2-ton floating hoist
- Emergency systems:
  - recompression chamber - 3-man, double-lock
  - rescue bell - 11-m depth
- Communication systems:
  - intercom - 20 stations, 24 channels
  - test subject - 2-way via umbilical
- Video system:
  - TV cameras - 2 topside, 9 under water
  - monitors - about 40, various sizes
  - recorders - 3 color broadcast compatible
- Instrumentation system: 200 channels, tank/control room

## SIX-DEGREE-OF-FREEDOM SHAKING TABLE: BUILDING 4663

A six-degree-of-freedom shaking table (motion system), which has a considerable amount of travel in translation (1.2-m horizontal stroke limit) and rotation, is located in the high-bay area on the first floor of Building 4663. This unique shaking table has an area of approximately 5.2 m x 4 m and a payload capacity of 10.5 tons. Independent, yet simultaneous, motion is achieved for all six degrees of freedom by the operation of six hydraulic actuators arranged in three bipod pairs between the platform and the floor (see Figure 16). Hydraulic actuator length calculations for imparting required body-fixed motions to the platform are normally included as a part of the computer program for simulation studies. Digital and analog computers are interfaced to this motion system and are located in an adjacent room. The actuators are powered by a 14-MPa, 450-l/min hydraulic system. The performance capability of the system is summarized in Table 3. Acceleration performance depends on the equipment mass attached to the platform.

Typical position interrelations of the six-degree-of-freedom shaking table are illustrated in Figure 17.

Figures 18, 19, and 20 show the operational limits of the yaw, roll, and pitch rotational capabilities, respectively.

The control room for operating the motion system is located adjacent to the high-bay area. It is provided with a large window for viewing motion system excursions. A control console in the room contains monitoring instruments, motion system controls, audio intercom, TV monitors, and two eight-channel strip-chart recorders. A removable patchboard is provided for versatility in circuit connections to the crew station instruments and controls.

Applications of the six-degree-of-freedom shaking table have included evaluations of Lunar Roving Vehicle driving, manned Space Shuttle Booster concept, surface effect ship motion for the U.S. Navy, motion cue threshold detection, solar electric propulsion system docking structure dynamics, Skylab Reboost docking mechanism verification, and the Apollo Docking System.

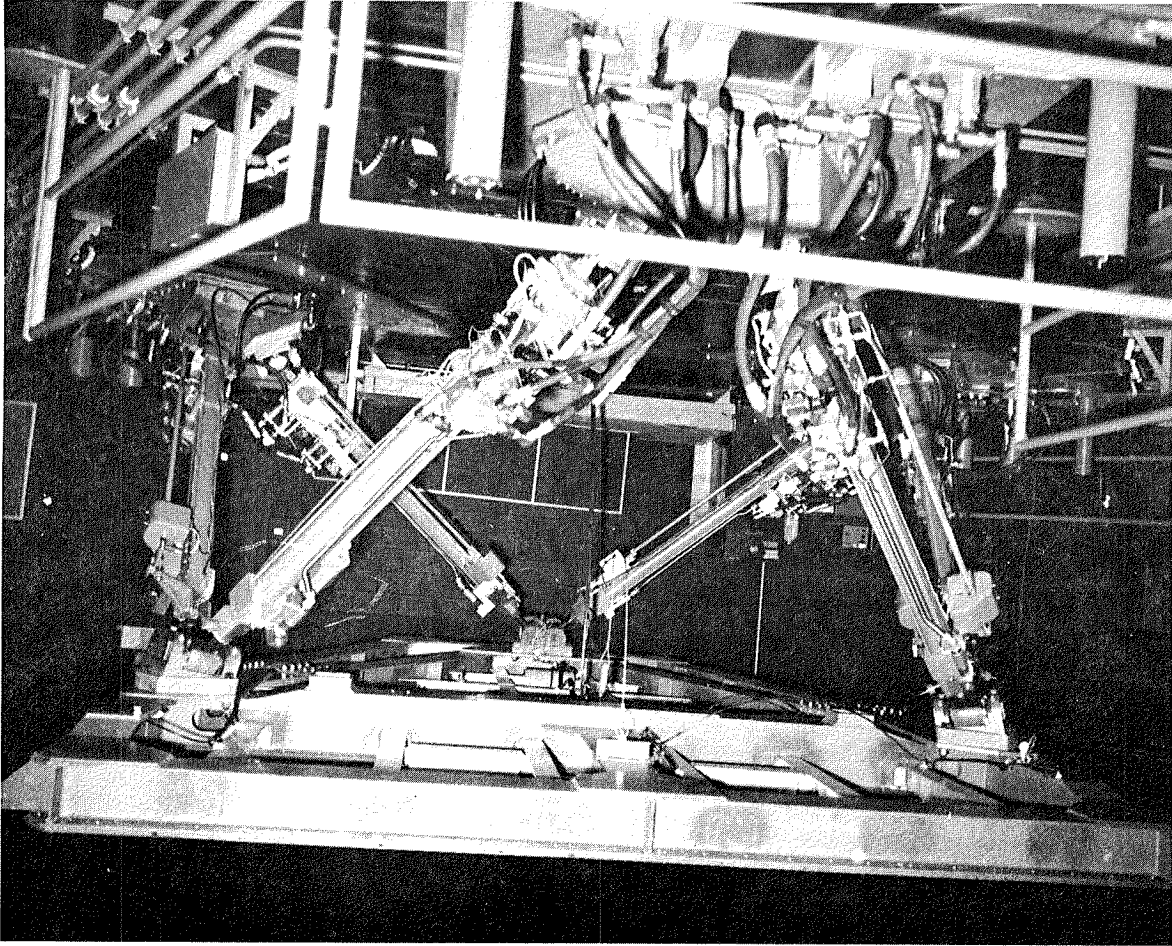

FIGURE 16 SIX-DEGREE-OF-FREEDOM SHAKING TABLE



TABLE 3  
PERFORMANCE OF SIX-DEGREE-OF-FREEDOM SHAKING TABLE

Motion	Position	Rate	Acceleration	
			No Load	10.5-Ton Load
Pitch	+30°, -20°	±15°/sec	±6.5 rad/sec <sup>2</sup>	±2 rad/sec <sup>2</sup>
Roll	±22°	±15°/sec	±7.0 rad/sec <sup>2</sup>	+1.6 } -2.0 } rad/sec <sup>2</sup>
Yaw	±32°	±15°/sec	±6.0 rad/sec <sup>2</sup>	±2.0 rad/sec <sup>2</sup>
Vertical	1.0 m up, 0.75 m down	±0.6 m/sec	±1.6g	±1.0g
Lateral	±1.2 m	±0.6 m/sec	±2.4g	±0.6g
Longitudinal	±1.2 m	±0.6 m/sec	±2.0g	±0.6g

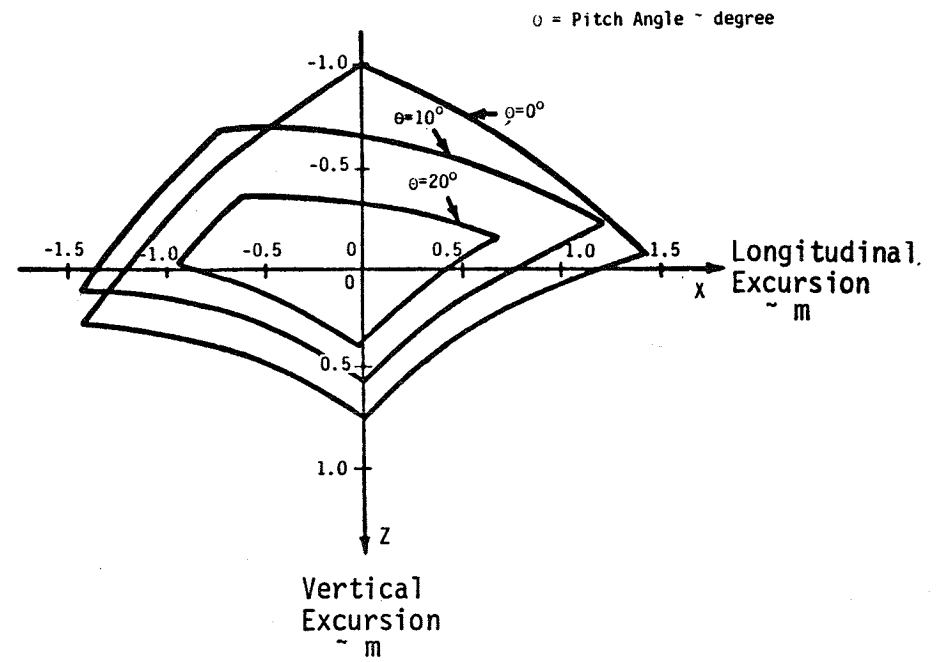
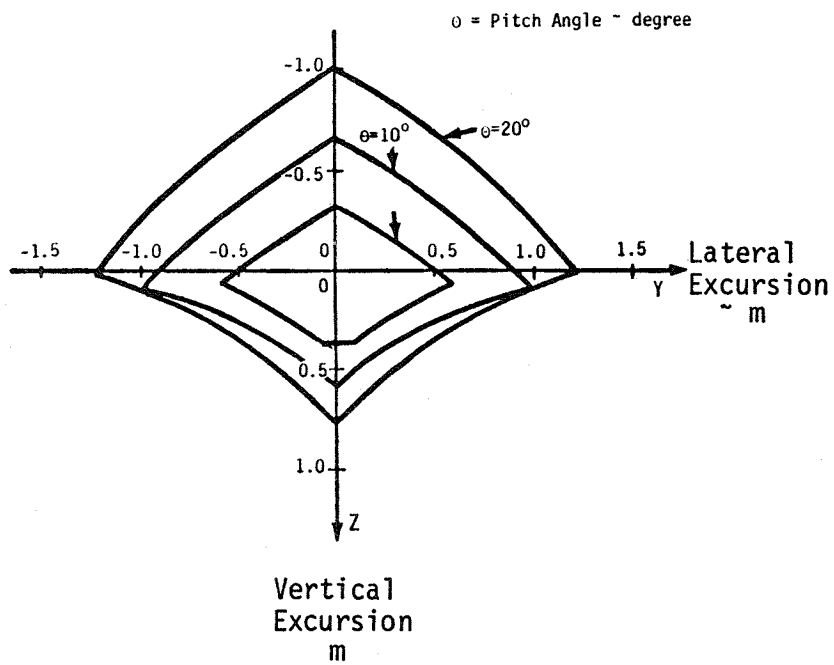

FIGURE 17. TYPICAL POSITION INTERRELATIONS OF SIX-DEGREE-OF-FREEDOM SHAKING TABLE

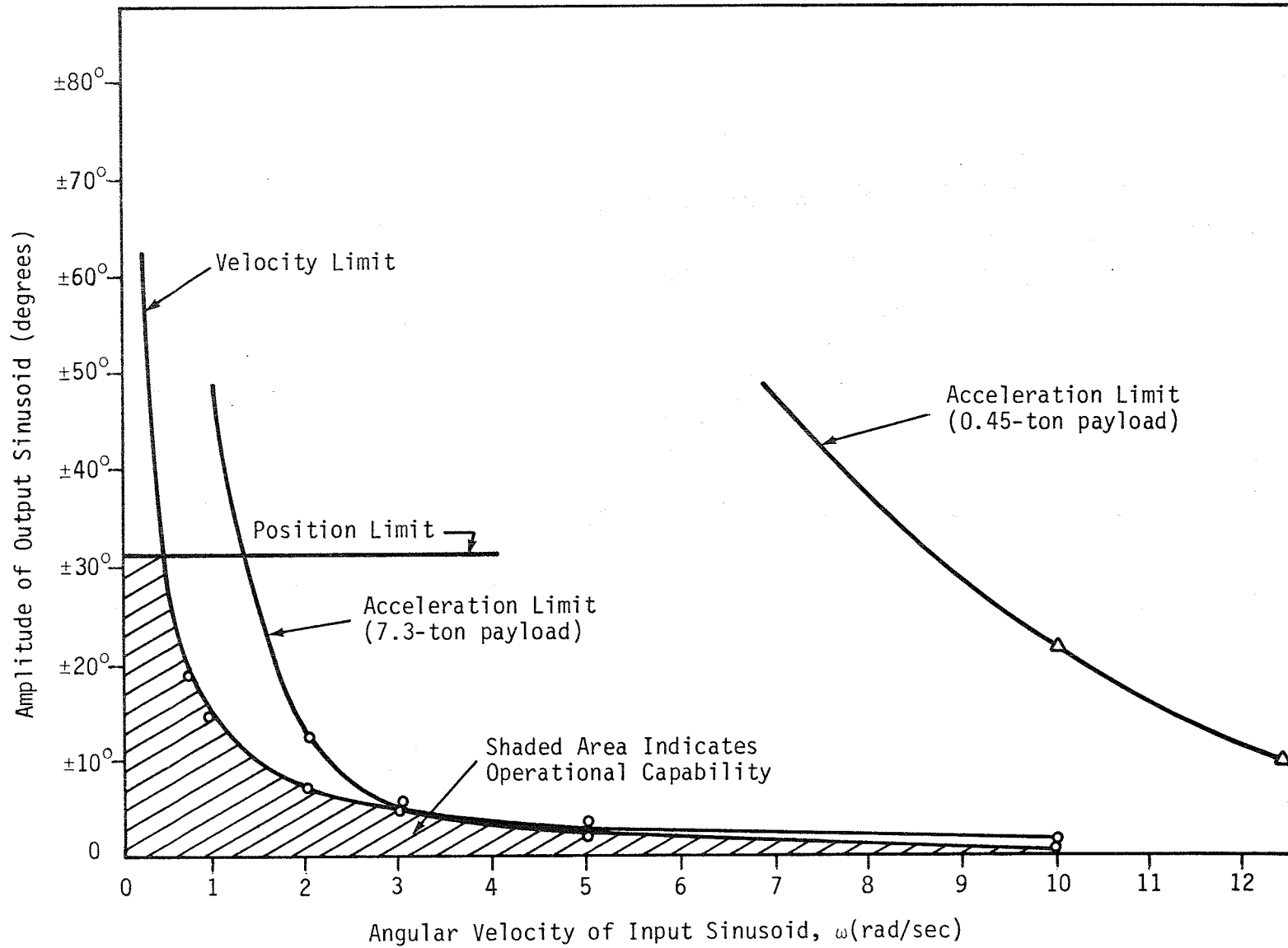

FIGURE 18 SIX-DEGREE-OF-FREEDOM SHAKING TABLE OPERATIONAL LIMITS: YAW

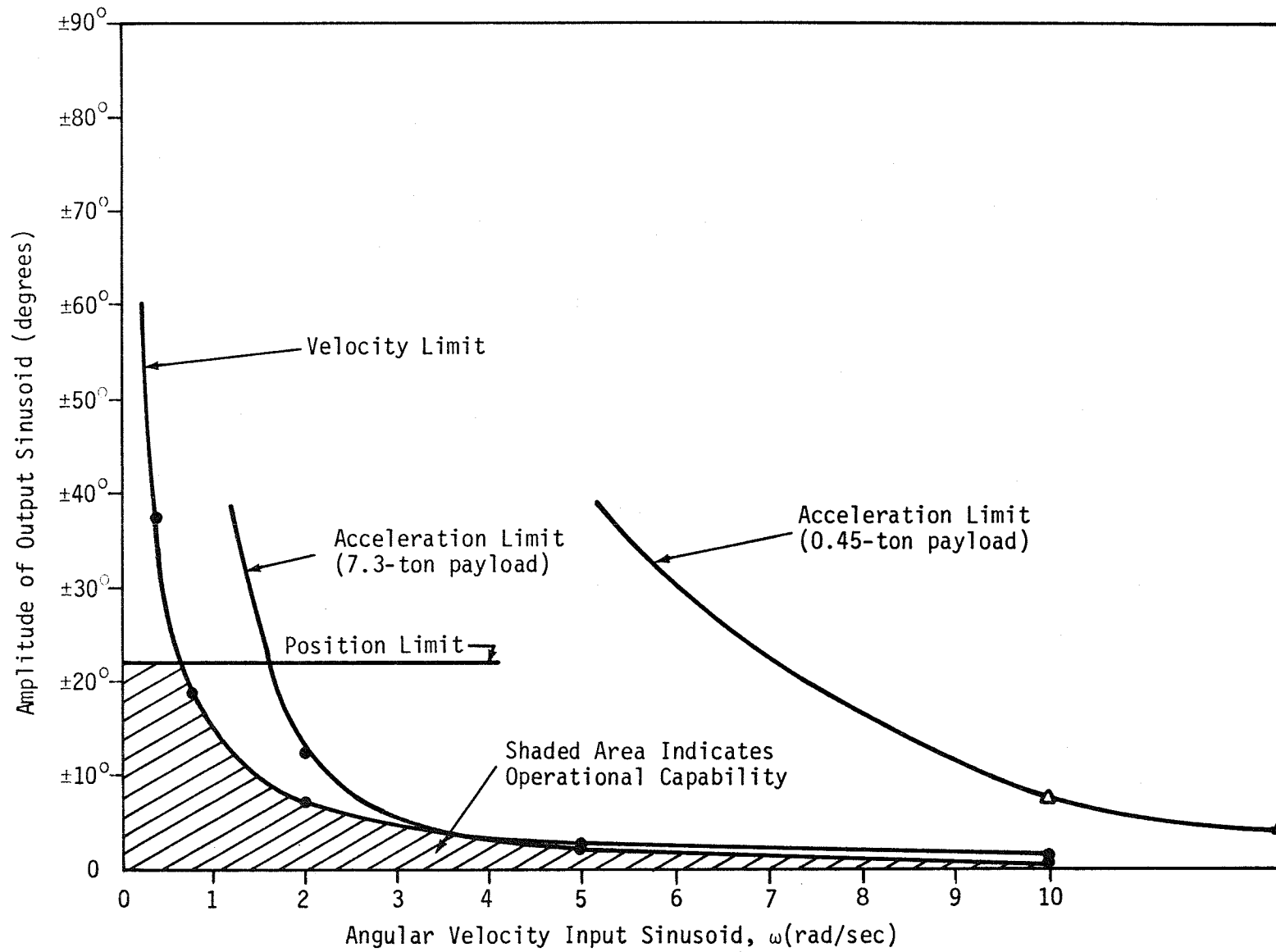

FIGURE 19 SIX-DEGREE-OF-FREEDOM SHAKING TABLE OPERATIONAL LIMITS: ROLL

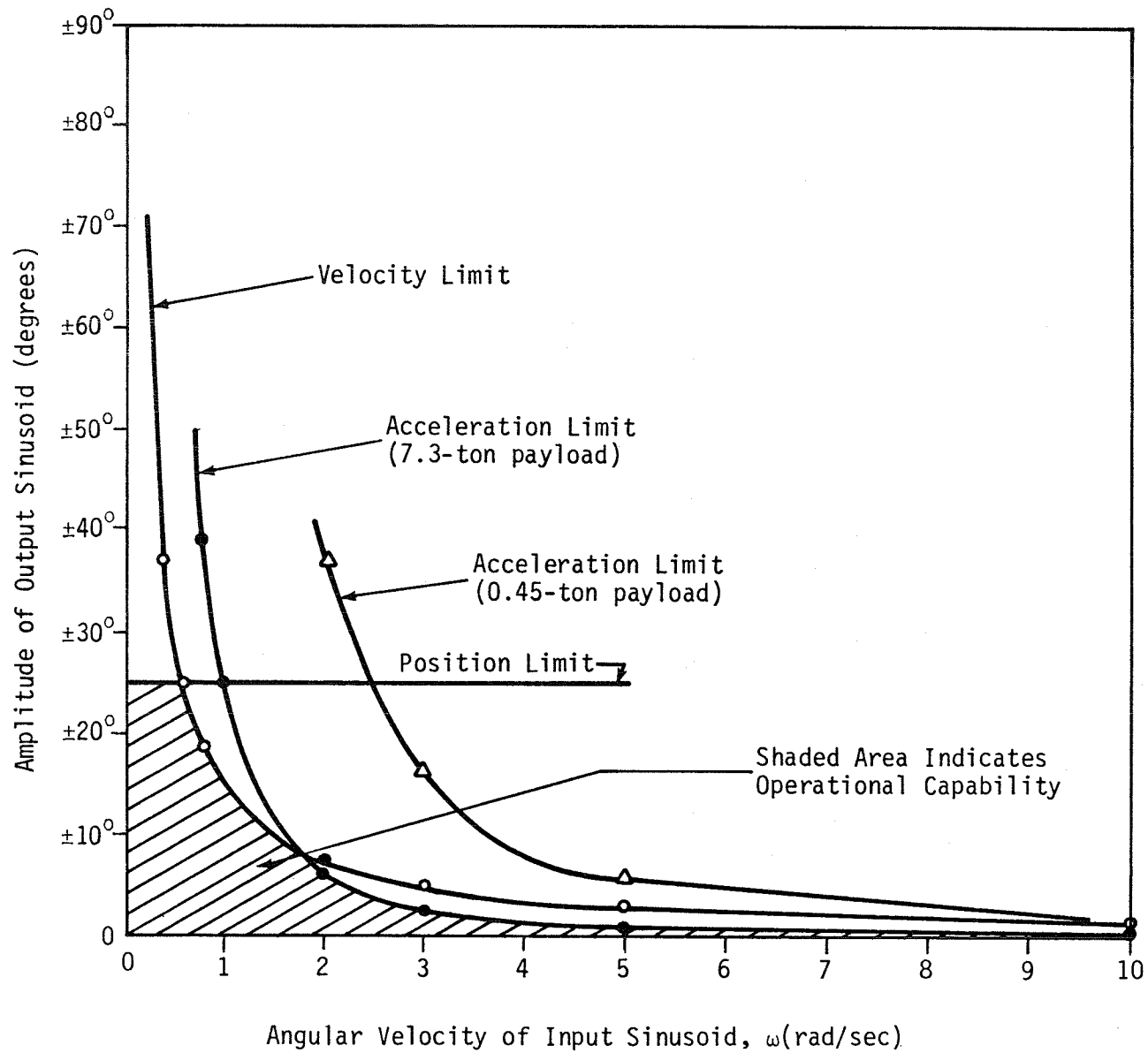

FIGURE 20 SIX-DEGREE-OF-FREEDOM SHAKING TABLE OPERATIONAL LIMITS: PITCH

## CENTRIFUGE: BUILDING 4487

The MSFC centrifuge has a 1.8-m radius to the center of gravity of the test specimen. The centrifuge arm can accommodate a payload or spacecraft component configuration that weighs up to 0.23 tons while rotating at a steady acceleration. A plan view and section of the facility are shown in Figure 21.

The centrifuge has two modes of operation: (1) steady-state acceleration and (2) vibration and acceleration. The first mode is capable of producing centrifugal forces of 100g on a 0.23-ton test specimen. The second mode includes two degrees of freedom -- longitudinal and lateral. The lateral motion is induced by attaching a mechanical vibrator to the test specimen. The second mode is capable of vibrating a 0.05-ton test specimen to 28g sine with a frequency range of 5 Hz to 2,000 Hz and to 20g random with a frequency range of 20 Hz to 2,000 Hz while subjecting it to a constant centrifugal force of 20g per unit mass of specimen.

The technical specifications for the first mode of operation, the steady acceleration mode, are as follows:

- Maximum specimen size: 0.91 m x 0.91 m x 0.76 m high
- Maximum specimen weight: 0.23 tons
- Maximum acceleration: 100g radial
- Slip rings at main spindle: 100 5-A low noise rings in addition to the rings needed for machine control equipment
- Radio frequency characteristics of slip rings at main spindle: 108 to 800 megacycles with loss factor of 3 dB maximum
- Television:
  - at machine center
  - resolution 1,000 lines vertical, 800 lines horizontal
  - monitor 425-mm minimum
  - turret lens, remotely controlled

The technical specifications for the second mode of operation, the vibration and acceleration mode, are as follows:

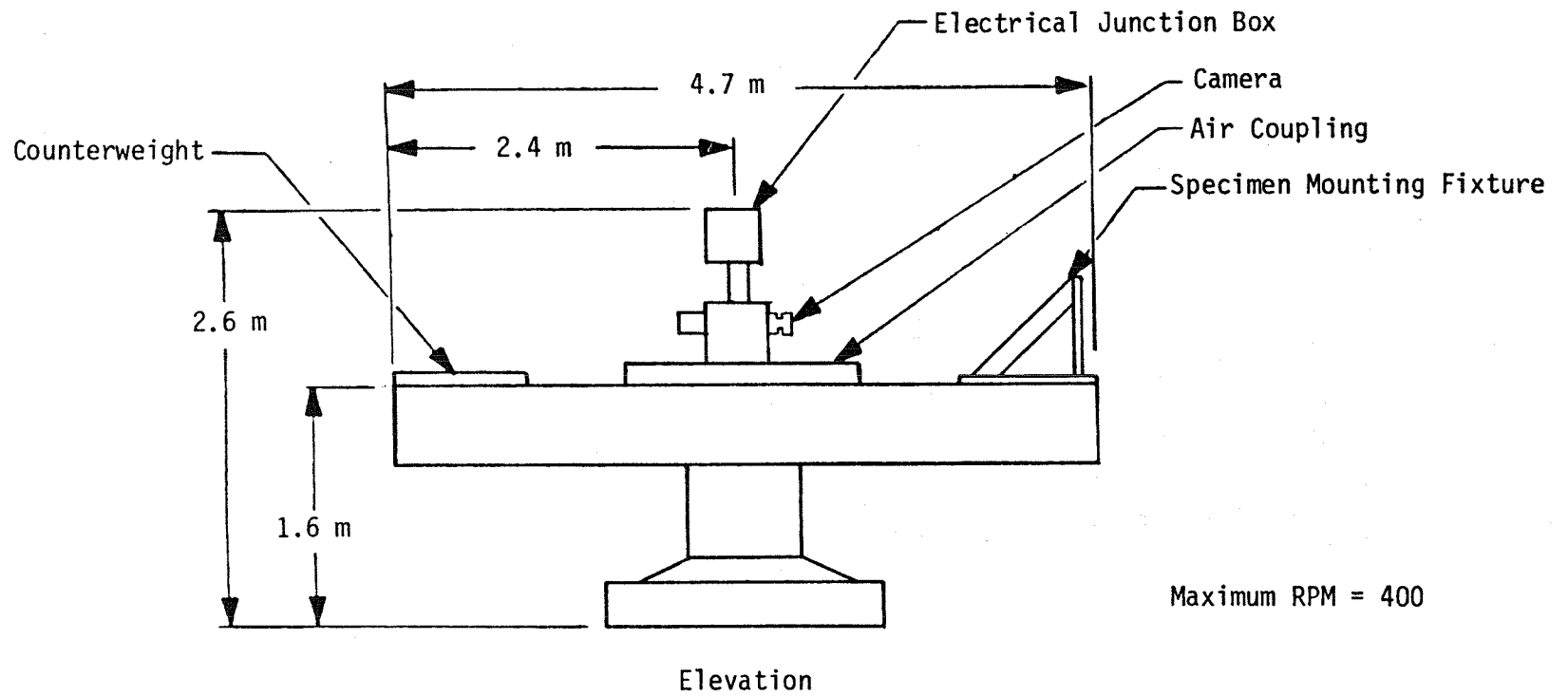
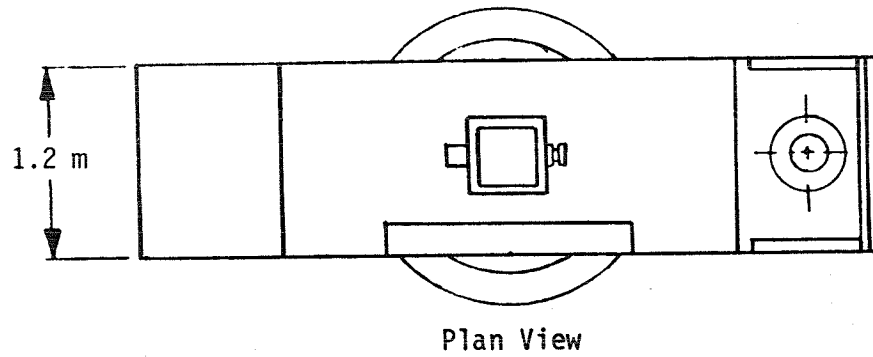

E-39

FIGURE 21 PLAN VIEW AND SECTION OF CENTRIFUGE

- Direction: vertical or radial
- Radius to center of gravity of specimen: 1.8 m
- Radial acceleration range during vibration: 0 to 20g
- Rated vibration force (sine vector): 1.81 tons
- Specimen mass and dynamic load limitations:
  - payload range at 10g, 0-to-peak sine vector:  
0 to 0.17 tons
  - payload range at 20g, 0-to-peak sine vector:  
0 to 0.079 tons
  - payload range at 100g, 0-to-peak sine vector:  
0 to 0.0068 tons
- Frequency range: 5 Hz to 2,000 Hz (sine); 20 Hz to 2,000 Hz (random); lower frequency limit of 5 Hz can be lowered further with existing solid-state amplifier
- Rated displacement: 25.4 mm peak-to-peak
- Rated velocity: 1,778 mm/sec
- Specimen platform size: 300-mm-diameter maximum
- Specimen height: 600-mm maximum
- Slip rings: same as first mode
- Radio frequency characteristics of slip rings at main spindle: same as first mode
- Television: same as first mode

Additional features are as follows:

- Constant-azimuth specimen orientation capability available under first mode of operation (steady-state acceleration only)
- Centrifuge system designed to accept expanded capability of testing specimens under vacuum in either mode of operation



## GEOTECHNICAL RESEARCH LABORATORY: BUILDING 4481

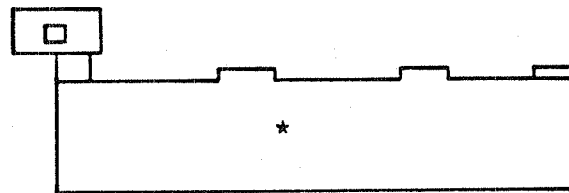

\*Rooms 313 and 313A

The Geotechnical Research Laboratory consists of a group of experimental systems that provide unique capabilities for basic and applied research on the mechanical behavior of granular and fine-grained, cohesive materials. The strength, compressibility, deformation characteristics, and elastic moduli of soils and rocks are measured in conjunction with studies on soil fabric and structure and the physicochemical interactions that take place in the solid and fluid phases of such multiphase (solid, liquid, gaseous) porous media under a variety of static, steady-state, and transient-dynamic, three-dimensional loading conditions. Figure 22 shows some of the experimental apparatus available.

Fundamental geotechnical research is vital to the solution of a broad range of problems related to earth and ocean physics, earth resources and environment, earthquake engineering, and other terrestrial applications programs. The research laboratory has supported principal investigator activities during the Apollo Program, wheel-soil interaction studies in support of the development and the mobility performance evaluation of the Lunar Roving Vehicle, and studies that have led to the development of other state-of-the-art mobility systems that are currently under consideration for post-Viking surface exploration of Mars. Currently, the laboratory is being utilized in support of development of Spacelab experiments related to the intrinsic mechanical properties and material behavior of multiphase porous media.

The following test apparatus are contained in the Geotechnical Research Laboratory:

- Major field sampling and ground-truth survey apparatus:
  - Acker drilling and sampling and sample recovery assembly (cores to 7 m in length)

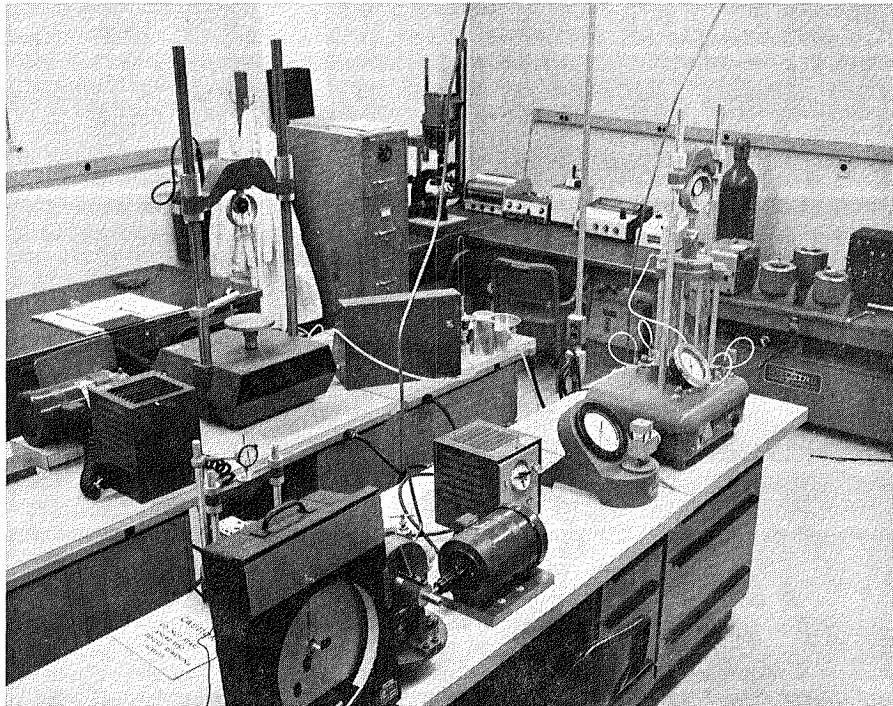
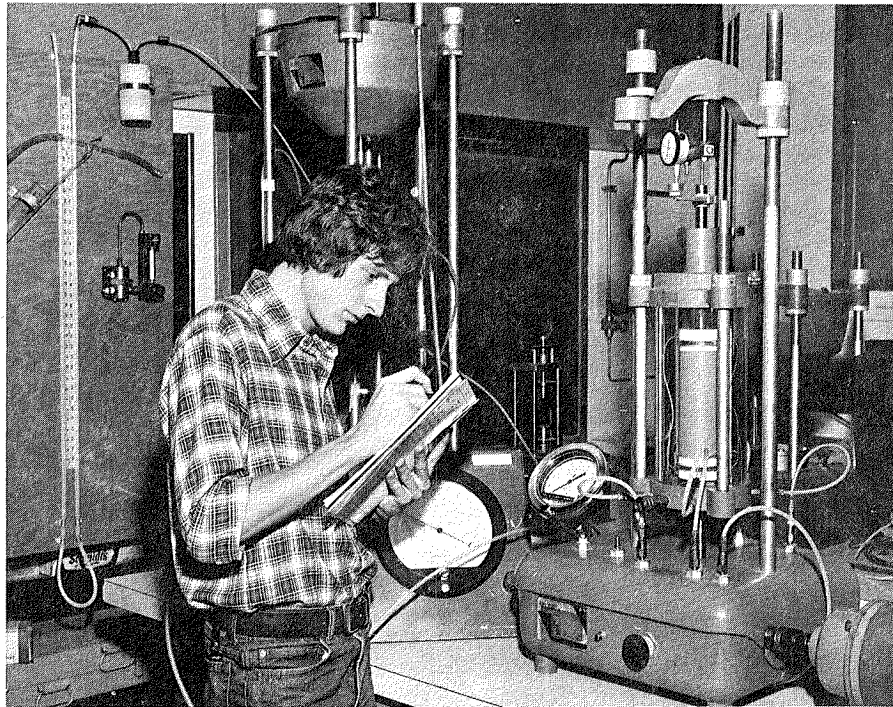

FIGURE 22 EXPERIMENTAL APPARATUS IN GEOTECHNICAL RESEARCH LABORATORY

- Troxler 1401 and 1603 soil density/moisture gauges employing gamma and neutron radiation techniques
- Terra Scout R-150 portable refraction seismograph
- Soiltest R-30 portable electrical resistivity meter
- a variety of portable soil-testing apparatus
- Major laboratory identification and classification apparatus:
  - apparatus for determining specific gravity, grain-size distribution, relative density, Atterberg limits, and moisture content of soil
  - Cenco L-12A gravity convection oven for soil samples
  - Ohaus 1000 electronic balance
  - Micro-Petralab, Model 1,106B thin sectioning unit
  - Leitz Ortholux light microscope for micro- and macro-photography
  - Coleman 21 flame photometer
  - Coleman Junior II spectrophotometer
  - Fisher 360 linear temperature programmer
  - Bausch and Lomb 240 stereomicroscope system
- Major soil and rock mechanical testing equipment:
  - Karrol Warner (KW) 530 and 541 strain- and stress-controlled triaxial compression systems
  - KW 545 and 567 unconfined compression systems
  - KW 570 direct shear apparatus
  - KW 354 consolidation apparatus
  - KW 53 pp and 53 pps pore-pressure gauges
  - Harvard miniature and Proctor compaction apparatus
  - unique and versatile wheel-soil interaction test system (accommodates 1/3- and 1/6-scale wheel models)
  - data acquisition system, including Hewlett Packard 9820A calculator system

## **APPENDIX F**

### **Structural Test and Data Acquisition System at NASA/MSFC**

# Structural Test and Data Acquisition System at NASA/MSFC

## 1. SYSTEM BACKGROUND AND OVERVIEW

The Structural Test and Data Acquisition System (STDAS) was developed for use in the Structures and Mechanics Laboratory at NASA/MSFC by Avco Information Systems of Huntsville, Alabama. Although the STDAS was designed to specifically meet the needs of the structural testing program for the Shuttle spacecraft, the system concept provides for a multitude of similar data acquisition applications.

The system will accommodate preparation and testing activity for two separate, simultaneous tests, with a total capacity of 6,000\* data channels. The number of data channels assigned to a given test is determined only by the test requirement, as long as the overall requirement does not exceed 6,000. To support a wide variety of test applications, each data channel can accommodate many types of passive transducers, such as strain gages, pressure sensors, load cells, and displacement sensors. Active transducers such as thermocouples, current shunts, and other voltage output devices can also be accommodated.

Data Selector Units (up to 2,000 channels per unit) can be positioned at remote test sites. These units are transportable and can be moved from site to site as test requirements dictate. Data from the remote units can be transmitted up to 3 miles via a serial data link over video lines to a central computer facility.

Accumulated data can be reduced and displayed while the test is in progress, enabling test operators and stress engineers to have maximum visibility with regard to the condition of the test article and the progress of the test. A variety of display techniques are employed to provide this continuous monitoring capability during the test as well as review of recorded data after the test is complete. Predicted and theoretical values for selected measurements can be presented and compared with accumulated data on the same display.

## 2. SUMMARY OF STDAS FUNCTIONAL SUBSYSTEMS

To provide the flexibility needed to accommodate a multitude of test configurations, the STDAS is divided into three functional subsystems. These subsystems are:

1. Static Input Unit (SIU) - 24 used
2. Data Selector Unit (DSU) - 3 used
3. Central Facility (CF) - 1 used (dual system)

A schematic of the interrelationship of the subsystems is given in Figure 1. The function and components of each of these subsystems are discussed in the following three sections. A more detailed description of the subsystems is given in *A Description of the Structural Test and Data Acquisition System (STDAS) for Testing of the Shuttle Vehicle* by Avco Electronics Division (November 1975; Revision B, June 1977).

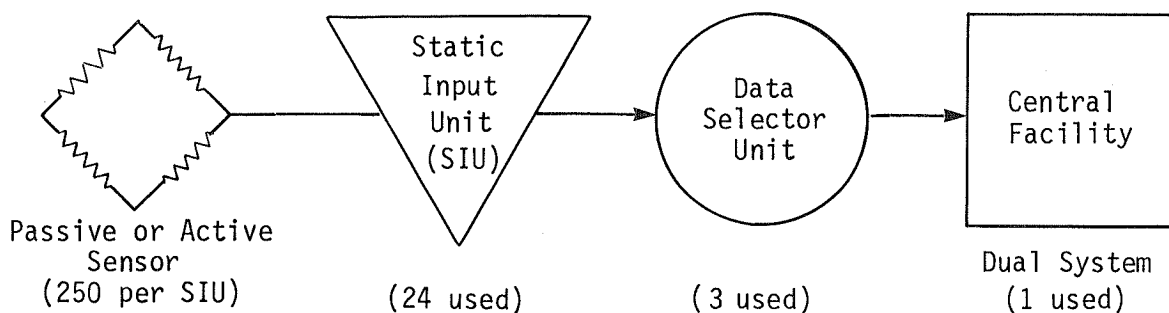

FIGURE 1 STRUCTURAL TEST AND DATA ACQUISITION SYSTEM (STDAS) FUNCTIONAL SUBSYSTEMS

### 3. STATIC INPUT UNIT (SIU)

Twenty-four SIUs supply the interface between the transducers and the data acquisition system. Each unit is a transportable subsystem that provides excitation, calibration, signal conditioning, and amplifier offset correction for as many as 250 transducer channels. Each channel can be configured to accommodate a wide spectrum of active or passive transducers by simply changing a plug-in module. The SIU scans the transducer signals at a fixed rate of 20 kilosamples/sec, digitizes the data, and transmits it via a high-speed, half-duplex serial data link to a DSU that is up to 1,600 ft away. The 24 SIUs can be distributed between two different tests in whatever proportion is required to accommodate the various data channel requirements. The number of SIUs that can be dedicated to a given test can vary from 1 to 24.

Each SIU offers the following features:

- preamplifier per channel with manually selectable gain range (X1, X16, X64)
- common transducer excitation power supplies (one per 32 channels)
- automatic gain-ranging or programmable gain at analog-to-digital converter (X1, X2, X4, X8, X16)
- computer for scan sequencing, averaging, and offset correction to reduce the burden on the DSU processor
- a transportable two-cabinet system with casters, lifting eyes, and forklift supports
- ability to reduce noise-induced errors by use of active 10-Hz filter in each channel
- high-common-mode rejection (120 db) from transducer input to digitized output
- $\pm 0.15\%$  system accuracy and 20-kHz scan frequency
- unattended remote operation
- separate galvo outputs
- current calibration technique for greater accuracy and lower cable cost

Each SIU contains the components and control devices shown in Figure 2.

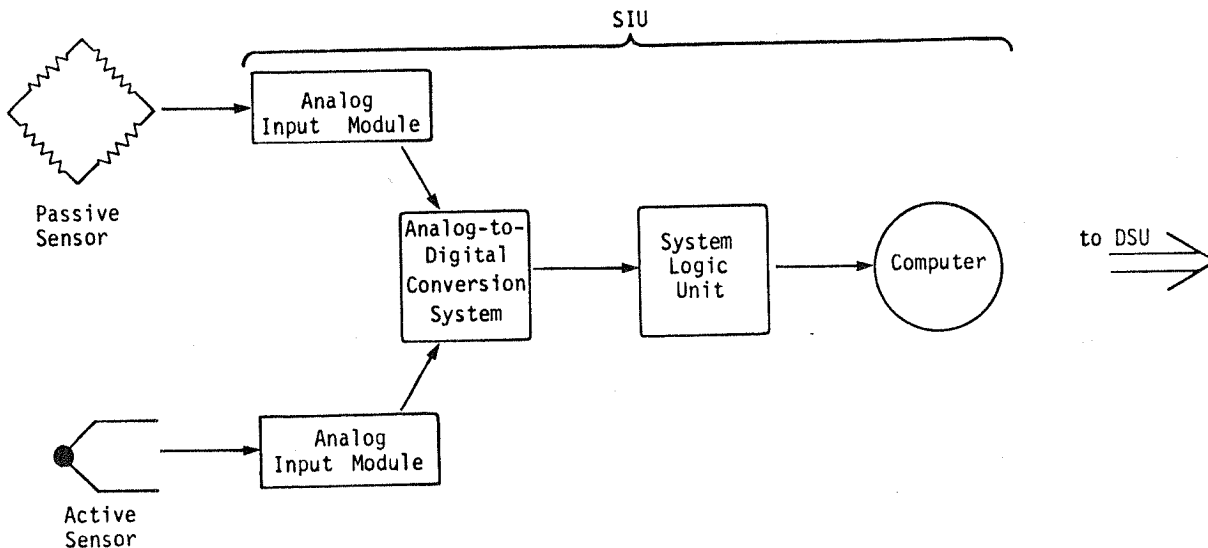

FIGURE 2 STATIC INPUT UNIT COMPONENTS

### SIU Subsystem Function

Each SIU is a transportable data acquisition system that provides transducer excitation, calibration, signal conditioning, amplification, multiplexing, digitizing, amplifier offset correction, and data averaging for up to 250 active and passive transducers. The SIU accepts and preamplifies the transducer's low-level signals with manually programmable amplifiers (one per channel) and further amplifies them with an automatic or computer-selected gain amplifier (one per SIU). The signals are then converted to binary data words that can be transmitted to the DSU via a high-speed, half-duplex serial transmission link up to 1,600 ft in length.

Data is digitized at the rate of 20 kilosamples/sec at the SIU. The maximum throughput rate between the SIU and DSU is 20 kilowords/sec for the averaged mode of data acquisition. In the averaged mode of operation, four samples are taken and averaged for each channel. The maximum sampling rate is 5 samples/sec for each channel when averaged data is being acquired.

The SIU has an overall three-sigma accuracy of  $\pm 0.15\%$  of full scale for eleven binary ranges from  $\pm 10$  MV to  $\pm 10.24$  V full scale. The SIU uses 12 bits and sign in an analog-to-digital converter for a resolution of  $\pm 0.024\%$  (or  $2.4 \mu\text{V}$  on the 10-MV range).



## SIU Subsystem Components

SIU Analog Input Module (AIM). The AIM provides the interconnection between the SIU-digitizing system and the transducer. The AIM consists of transducer signal conditioning, a differential preamplifier with a filtered output (10 Hz) to the analog-to-digital conversion system, and a galvo-buffer output where required. Signal conditioning consists of plug-in bridge completion, as well as voltage and transducer calibration circuits. Transducer excitation is provided by a common excitation power supply (SRC/Moxon) for every 32 AIMS; therefore, each SIU requires eight excitation power supplies. The AIM is rated at 10 V operating common mode and protected to 50 V common mode.

SIU Analog-to-Digital Conversion System (Preston Scientific). The multiplexed output of all 250 AIMS is applied to an automatic gain-ranging amplifier that amplifies each input channel's analog signal to the proper level for conversion to a binary number by the analog-to-digital (A/D) converter. This amplifier can change gains automatically (between samples) or may be programmed from the SIU computer while sampling at a 20-kHz rate. A gain code is transmitted to the DSU along with the output of the A/D converter. (Gains available are X1, X2, X4, X8, and X16.)

The multiplexer consists of 256 differential, field-effect-transistor (FET), switched channels located in the analog-to-digital conversion system chassis. The high-speed A/D converter codes each data sample into a sign and 12 binary bits for transmission along with the post amplifier gain through the data link to the DSU.

SIU Computer (Modular Computer Systems Corp.). The SIU computer (ModComp II/05 with a core memory of 8,000, 16-bit words) stores the 250-channel address and post-amplifier gain selection words. In addition, it provides the necessary control signals, data averaging, and amplifier offset correction for the data before it is transmitted to the DSU. The SIU computer is both hardware- and software-compatible with the DSU and CF computers.

The SIU computer initiates data transmission to a DSU over a half-duplex, serial transmission link at a burst rate of 62.5 kilowords/sec. Transmission distances of up to 1,600 ft can be utilized.

SIU Control Panel (Avco). Each SIU has a system control panel for manually selecting and displaying the data from a particular multiplexer channel. In addition, controls are provided to select the current or voltage calibration function of any channel. The system control panel is an integral part of the system logic unit.

SIU Programmable DC Voltage Standard (Electronic Development Corp.). A voltage source for use in voltage calibration of the system is provided. This unit is programmable and capable of providing calibration voltages of  $\pm 0.01\%$  accuracy for ranges of 100 MV and 10 V full scale.

#### SIU Environment

The SIU is capable of operating over a range of about 40°F to 75°F and 40% to 60% relative humidity while maintaining a system accuracy of  $\pm 0.15\%$  or better.

#### SIU Operation Description

During test operation, the SIU is a slave to the DSU in that all functions, such as acquiring data, calibrating the system, and performing statistical analysis, are accomplished under the command of the DSU. The operating program for control of the SIU is down-loaded from the DSU over the serial data link, and the program is initiated upon completion of the loading procedure. No manual intervention is required at the SIU to accomplish this.

The data link control gives the DSU the complete control of the SIU in the on-line mode of operation. In addition, each SIU has extensive manual control capability by means of the system control panel (described above) when the SIU is off-line from the DSU.

#### 4. DATA SELECTOR UNIT (DSU)

Four DSUs are provided to act as focal points for controlling data acquisition for two separate tests. Each DSU performs data reduction, limit checking, recording, and display of data obtained from up to eight SIUs, or 2,000 data channels, while it sends scan sequence data, calibration commands, and amplifier gain settings to each SIU. Also, as the data is being collected by the DSU, it is transmitted as far as three miles to the CF via a serial data link over video lines. Each test being monitored by the system must have at least one DSU assigned to it. Depending on the data channel requirements, as many as three DSUs can be assigned to a single test.

Each DSU offers the following features:

- interpretation and processing of operator commands
- formatting and displaying of data on video displays and a line printer
- formatting of raw data for recording on a magnetic tape unit
- alarm limit checking for high and low limits
- interfacing to the CF and eight SIUs
- engineering calculations
- transducer offset correction

The principal components and control devices of each DSU are shown in Figure 3.

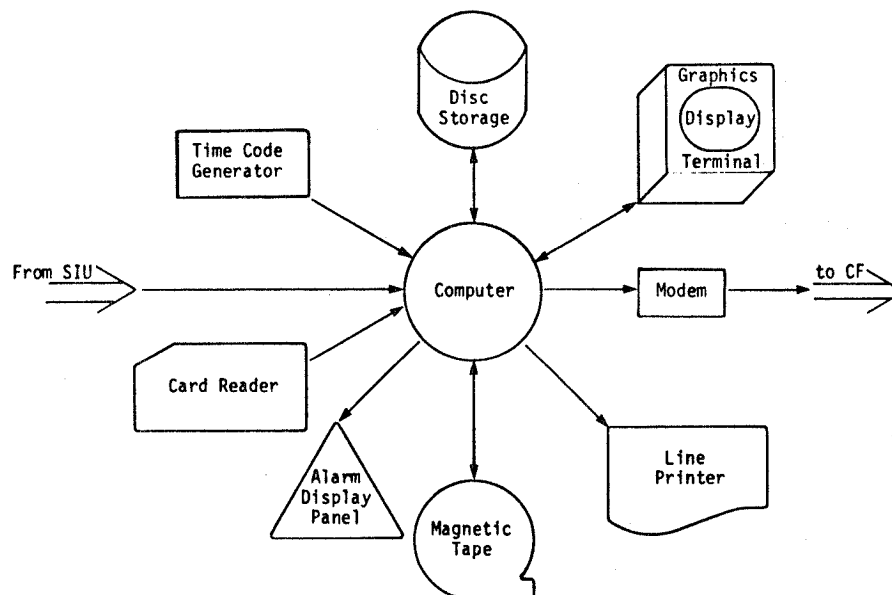

FIGURE 3 DATA SELECTOR UNIT COMPONENTS

### DSU Subsystem Function

Each of the four DSUs functions as a secondary computing subsystem in the STDAS distributive network. A DSU serves as a data concentrator for up to eight SIUs, performs validity and conversion analysis of acquired data, presents results of analyzed data on various output devices, records data on both temporary and permanent storage media, and completes transfer of the data to the CF.

As a data concentrator, the DSU receives data from each SIU in an averaged or unaveraged mode. In either mode, the total transfer rate into the DSU from the SIUs can not exceed 20 kilosamples/sec. This rate can be realized by one channel being sampled 20,000 times per second to 2,000 channels each being sampled 10 times per second. The system will accommodate virtually any combination of sampling rate and number of channels as long as the system constraint of 20 kilosamples/sec is not violated.

Once real-time data has been received by a DSU, it proceeds, under operator direction, to verify that the data is within the full-scale limits of the system and then to convert the data into engineering units.

Data converted into engineering units can subsequently be hard-copied by a line printer, presented for display on a graphic or annunciator display, and compared against a high-low threshold limit. If the limit is exceeded, a transfer to the alarm relay panel can be initiated.

Under operator direction, data can be routed to the system disc for temporary storage or to a magnetic tape unit for permanent storage. Data recorded on the system disc is used for updating system displays and for hard-copy output. Data recorded on magnetic tape provides a history of test specimen behavior.

### DSU Subsystem Components

DSU Magnetic Tape Storage (Wangco). The magnetic tape unit is a 1,600-bits/in., 9-track, 75 in./sec unit with a single controller at the DSU. The controller is capable of handling four tape drives; however, design of this system requires operation of only one drive. For future expansion, a second drive

could be added for additional storage capacity. The software system switches automatically from one drive to the other when an end-of-tape marker is sensed. These tape units are used for permanent or interim storage of data.

DSU Card Reader (Documation). The DSU has a 1,000 card/min card reader used for the preparation and input of data.

DSU Mass Storage - Disc Cartridge (Diablo). Each DSU contains a moving-head disc system with a removable cartridge that has a 1.28-million, 16-bit word capacity and is used for program and data storage.

DSU Graphic Display Subsystem (Hazeltine). Each DSU contains one dedicated cathode ray tube (CRT) with a keyboard to be used by the test conductor for controlling data acquisition and test monitoring. The subsystem contains the following hardware characteristics: 5 x 7 dot matrix character generator, 512 x 480 points graphic resolution, and hardware vector generation.

Three annunciator CRTs are furnished with each DSU, although each DSU has the capability to handle up to 12 annunciator CRTs with no performance degradation. These CRTs have alphanumeric capability only (7 x 9 dot matrix character generation), with a resolution of 256 x 240 points. Character height is a nominal 0.4 in. The diagonal measure of the screen is 17 in. Each CRT can display a maximum of 15 lines with 20 alphanumeric characters per line. CRTs may be located up to 200 ft from the DSU.

DSU Line Printer (Centronics). Each DSU has an impact printer for data printout. The print rate is a nominal 100 lines/min with a 64-character font and 132 column lines. The printer is operable up to 200 ft from the DSU.

DSU Time Code Generator (SRC/Moxon). The time code generator at each DSU provides date and time information that may be read by the computer. It also provides slow code outputs of 50 pps, 10 pps, 1 pps, 6 ppm, 1 ppm and fixed pulse rates of 1 pps, 10 pps, 100 pps, and 1,000 pps available for external use. This unit is used to provide time synchronization among the individual computers of the system and as the time identifier for all re-

corded data. The generator may be synchronized to the CF over a land line for accurate time correlation.

DSU Computer (Modular Computer Systems Corp.). The DSU includes a ModComp IV/25 computer with a core memory of 64,000, 16-bit words. It is the control center for the data system operation. A 30-character/sec operator's console, manufactured by GE, is used as the operator interface.

DSU Modem (Computer Transmission Corporation). Each DSU is interfaced through modems to the CF. These modems, operating in a half-duplex mode over wide-band video cables, allow data to be transferred between the two sites at a rate of 921,600 bits/sec.

DSU Alarm Relay Interface (Avco). An interface at the DSU provides control of alarm relays assignable to selected SIU channels. A single indicator and audible alarm are provided. These are activated when one alarm condition exists for any channel. The alarm display panel is operable up to 200 ft from the DSU.

#### DSU Operation Description

Functionally, the DSU is configured to support two primary modes of operation: pretest and test. The pretest mode is composed of an event trail (question, answer, and instruction procedure) to aid the operator with test definition. The test mode consists of real-time data acquisition, recording, and display of transducer measurements.

In the pretest mode the operator initiates operation of the following software functions:

- set-up
- display definition
- calibration
- statistical analysis

Set-up and display definition provide the operator with a capability to define both the hardware configuration and system performance parameters for

the test mode. Specifically, the operator is able to assign analog channels to a test, identify the scan sequence for these analog channels, identify the types of transducers associated with this test, input linearization data, define graphic subsystem displays, format line printer output, and identify pseudomeasurements. This information is legality-checked and formatted on magnetic tape for later input into the system as a prelude to test initiation.

During calibration, the SIU's analog system is voltage-calibrated to detect amplifier gain and conversion errors, and, additionally, transducers are current-calibrated to verify the integrity of the measuring device. Because balancing of transducers is not required, a zero reference data scan is obtained, converted to a voltage reading, and stored on disc for later use during the test mode.

The statistical analysis function performs a noise-level check by repetitive sampling of each data channel. The function pictorially represents the analyzed data as a normal distribution function, calculating a three-sigma deviation.

The end of the pretest mode is signified by the permanent recording of the data base constructed during this period and, if desired, by the routing of this same data to the CF. It should be noted that the pretest mode can be reentered, once data acquisition has begun, by placing the test mode in a "hold" state. At this time, the test conductor can modify the data base (system in pretest) and resume testing without a complete redefinition of the test.

Once the pretest mode has been satisfactorily completed, the operator can enter test mode. Data acquisition in the test mode can be initiated by operator command at random intervals, periodically time-initiated, or based on the magnitude of a repeatedly interrogated load or pressure channel. The amount of data sampled can vary from one scan of each channel, to continuous data sampling of each channel until commanded to stop, or to burst scanning where data is acquired continuously within time intervals.

As a further refinement of scan control, channels can be randomly assigned to any of four group scans. These groups can be commanded to scan independently of each other or they can be commanded to scan integrally.

When a scan is initiated, the DSU signals its SIUs to scan utilizing the scan sequence tables previously down-loaded. Upon receipt of a scan command, the SIU executes a scan and transfers a 250-word block of data to the DSU. The DSU collates, time tags, and blocks the scans from all SIUs it is controlling for transfer to the CF.

Commensurate with the routing of data to the CF, the DSU temporarily stores data on disc, or, if no data is being transmitted to the CF, the DSU stores data on magnetic tape. The operator may opt to make this data a part of the permanent record in the event of a specimen failure or malfunction. The magnetic tape subsystem can record data at the maximum DSU system throughput rate of 20 kilowords/sec. The disc recording rate varies according to the number of channels defined for this test and the scan rate.

Acquired data, in raw counts, is converted into engineering units using transformation equations. This data is then ready for display on either or all of the following devices:

- control CRT
- annunciator CRT
- line printer

The control CRT unit is used for plotting data acquired in real time and is automatically updated as subsequent data scans are received. An operator may choose to have this data plotted in any one of the following ways:

- measurement vs. %-load
- measurement vs. psi
- measurement vs. time
- measurement vs. scan
- measurement vs. measurement
- profile distribution



where measurement refers to strain, temperature, load, pressure displacement, voltage, level, flow, or stress.

The annunciator CRTs (total of 12 in the STDAS) can be distributed among the four DSUs in any combination, or all can be accommodated by a single DSU. Each annunciator CRT can display as many as 13 measurements, where each measurement contains a measurement identification number, engineering unit representation of the data, and units.

The annunciator CRTs are only capable of displaying alphanumerics, whereas the control CRT possesses keyboard input, alphanumeric display generation, and graphic plotting capability.

Operator-selected print output is routed to the DSU line printer automatically. Those measurements selected for line printer hard copy are displayed in a variety of formats. Measurements can be printed as stand-alone values, averaged, compared against a theoretical tolerance, or panted when they exceed an out-of-limits check.

In addition, each DSU contains a 96-channel high- and low-limit alarm system. Those measurements identified for alarm relay panel display are compared against the high and low engineering unit limits specified for that channel; if an out-of-limits condition occurs, a high or low light-indicator and audible-alarm signal is activated. When this condition occurs, the measurements are automatically displayed on an assigned area of the control CRT.

## 5. CENTRAL FACILITY (CF)

The CF is the focal point for all data collected from as many as four DSUs. All data is recorded on magnetic tape and is available for display on six line-printers, five graphic display units, and a printer-plotter. Three of the sophisticated, fast-response graphic displays provide for real-time evaluation by stress analysts. Also, in the event of a failure in a DSU test conductor's graphics terminal, one test can be controlled from the CF.

Since the CF consists of two central processors, considerable flexibility can be realized. A key feature is the ability to recover from peripheral failures without jeopardizing the successful completion of any testing in progress.

The principal components of the dual CF are shown in Figure 4.

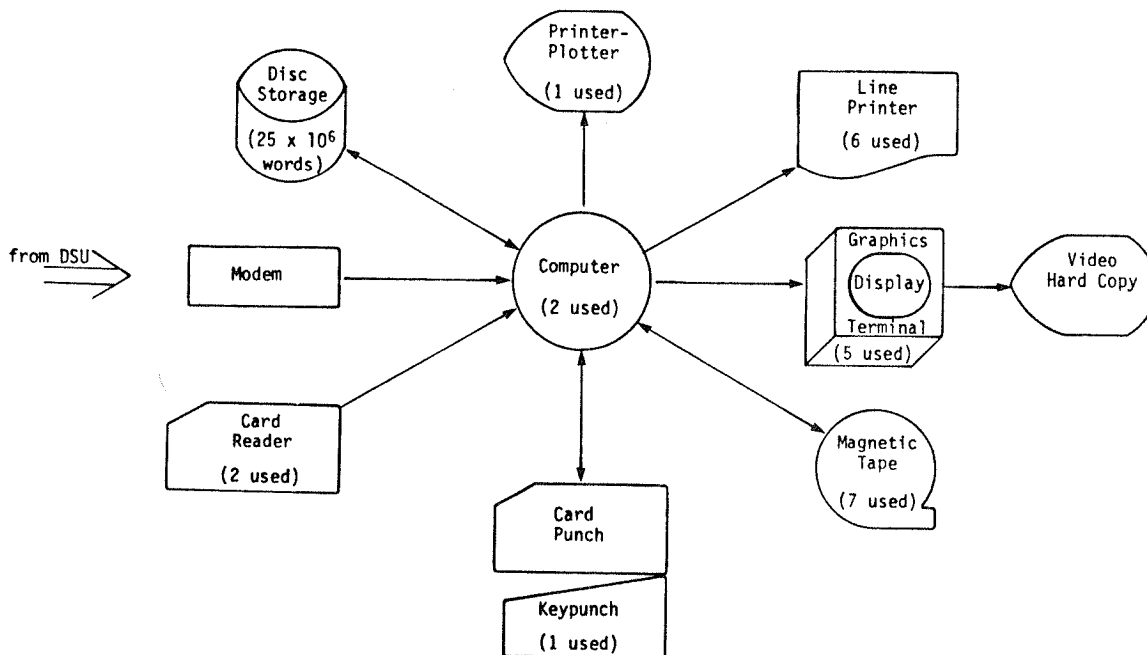

FIGURE 4 CENTRAL FACILITY COMPONENTS

### CF Subsystem Function

The relationship of the CF to the DSUs is similar to the relationship between the DSUs and the SIUs in that the CF serves as a data concentrator for up to four DSUs. The resultant data is stored on temporary and permanent mass storage media for future off-line reduction and playback. The CF also performs data conversion and presents the results on a variety of displays and printouts. Since the DSUs cannot communicate directly with each other, the CF becomes the essential link that ties the entire system together at a central point. Communication and control between DSUs is always accomplished via the CF, which may be located up to 3 miles away from any DSU.

As a concentrator, the CF receives data from each DSU in 2,000-word blocks and routes this data to the system disc and to magnetic tapes. The maximum data transfer rate into the CF is 40 kilosamples/sec and the maximum data transfer rate from any one DSU is 20 kilosamples/sec. Any combination of data transfer rates from the DSUs can be accommodated provided these constraints are not violated.

Once the data has been received, various measurements, selected by the test conductor, are converted to engineering units and displayed on the CRTs or listed on the line printers. Several different combinations of measurements may be displayed in alphanumeric or graphic form while other measurements are being listed.

Testing operations are normally controlled from a master DSU where the test conductor enters his commands via the CRT keyboard. If it is a single-DSU test configuration, the DSU executes commands independently of CF coordination. If it is a multi-DSU configuration, the commands are also sent to the CF where they are then routed to each slave DSU for execution. As an option, the test conductor may control the entire testing operation from the CF with all the DSUs involved operating as slaves. Simultaneous control from the CF and DSUs is not possible.

### CF Subsystem Components

CF Computer (Modular Computer Systems Corp.). The CF contains two ModComp IV/25 computers with a core memory of 64,000, 16-bit words. The CF has a

large number of computer peripherals. Some of these are dedicated to a particular computer, while others are switchable to either processor.

CF Dedicated Peripherals. The following peripherals are provided as a dedicated device to each processor.

- Card Reader (Documation) - The card reader is identical to the DSU unit described above.
- Card Punch/Key punch (Univac) - A nominal 35-cards/min on-line card punch is used for generating and duplicating card decks. It can also be used as an off-line keypunch and verifier.
- Console Device (General Electric) - A GE Terminet (keyboard and 30-character/sec printer) is provided as an operator control device for each computer.
- Time Code Generator (SRC/Moxon) - The CF time code generator provides date and time data on request to either processor through a dual-port interface. This unit also serves as the master reference to which all DSU time code generators may be synchronized. It, in turn, may be synchronized to an external interrange instrumentation group reference.

CF Switchable Peripherals. The following devices are switchable under manual control to either processor in order to dynamically configure the system to the work load or recover from failures.

- Mass Storage-Disc Packs (Information Storage Systems) - Two moving-head disc drives with removable disc packs are provided for program and data storage. Each disc has a capacity of 12.47-million words. These discs are manually switchable to either processor, but the software will not support more than one disc on a given processor.
- Line Printer (Data Printer Corporation) - Six impact-type printers with 600 lines/min average print speed, 64 character font, and 132 columns, are provided for hard copy display of data. These devices are switchable in pairs under manual control to either processor as work load dictates.
- Magnetic Tape Units (Wangco) - Seven magnetic tape drives, six of which are identical to those at the DSU, and four controllers are provided for data storage. Six drives are 9-track and record at 75 in./sec, 1,600 bits/in.; one is 7-track and records

at 75 in./sec, 556 to 800 bits/in. Each of the three pairs of 9-track drives and the 7-track drive can be switched under manual control to either processor as the work load dictates. All of the transports accommodate 2,400 ft tape reels.

- Printer/Plotter (Versatec) - One electro-static printer-plotter unit can be switched under manual control to either processor as work load dictates. Overall print rate is approximately 500 lines/min when printing only. Plot rate is approximately 1.2 in./sec.
- Graphics Display Subsystem (Hazeltine) - Five graphic display units, each of which includes a keyboard, are interfaced to the processors through a single, dual-port controller. The units provide the man-machine interface for operators and stress analysts. Additionally, four Tektronix hard-copy units are provided, three of which are dedicated to single CRT units, and one of which is shared by two CRT units. Three of the CRTs with hard-copy capability are physically located in the stress analyst (SA) area. These three units are assignable by software control to either of the processors as the work load dictates. The remaining two units are located in the CF computer room, and each is assigned to a processor. The CRTs have the following characteristics:
  - alphanumeric/vector, circle, and ellipse generation capability
  - 17-in. diagonal screen
  - 35 lines of 73 characters per line
  - 512 x 480 point plot capability
  - screen divisible into quadrants to display 4 independent plots
  - three shades of intensity
  - separate keyboard
  - hard-copy unit
- Modems (Computer Transmission Corporation) - Four modems (one communicating with each DSU), individually switchable under manual control to either processor, transmit and receive data over video lines. The modems operate at a data rate of 921,600 bits/sec and are identical to those used in the DSUs described above.

### CF Operation Description

Functionally, the CF is configured to support three primary modes of operation: pretest, test, and posttest. Pretest mode is used to build the data

base on the system disc. The data base contains all the information required to fully define and execute each measurement that is to be made; the conversion methods, if any, that are to be used; how and where the resultant data is to be displayed; and where it is to be stored for posttest reduction. Test mode consists of real-time data acquisition from the DSUs along with data conversion and display. Posttest mode is used to reduce the raw data acquired in test mode and to produce various CRT graphic displays, hard copy plots, and line-printer listings.

In pretest mode, the test conductor selects one of the following software functions from a menu displayed on the control CRT.

- set-up
- display definition
- calibration
- statistical analysis

Normally, each DSU involved with a test performs the pretest function locally, and, after satisfactory completion, the CF checks and merges these inputs into a final data base for use in test mode. Provisions have been made, however, for the entire pretest function to be performed at the CF and for the necessary portions of the data base to be sent to the appropriate DSU. Pretest mode is performed at the CF in the same manner as it is at the DSUs. This operation is explained in detail under DSU Operation Description.

In test mode, the CF accepts the data from each DSU involved with the test and stores it temporarily on the system disc and permanently on magnetic tape for posttest use.

The test conductor at the control CRT may assign any or all of three stress analyst CRTs to any test. The stress analyst may then request alphanumeric or graphic displays of various measurements. The control CRT also has this capability, but, unlike the control CRT at the DSU, all CRTs at the CF can provide four-quadrant graphic displays. Any of the measurements that can be displayed on the DSU control CRT can be presented as either a full-screen

or single-quadrant display on any CF CRT. In addition, the three-quadrant deflection distribution plot can be displayed. The control and stress analyst CRTs can also select measurements for line-printer output, similar to the DSU control CRT. Unlike the control CRT, the stress analyst stations have no control over the operation of the test.

When a test is being controlled from the CF, each DSU on that test operates in the slave mode with its control CRT and keyboard disabled. The alphanumeric displays on the annunciator CRTs are controlled from the control CRT at the CF.

In posttest mode, the raw data tape produced in test mode is read, converted to engineering units, and written back out on a second magnetic tape. This second tape is then used to provide various graphic displays, hard-copy printouts, hard-copy plots on the Versatec printer-plotter, and also the seven-track plot tape used by the III Model FR-80 plotting system currently installed at NASA. The control and stress analyst CRTs are used in the same manner as they were in test mode for defining displays and line printer output. The test conductor or stress analyst(s) can request a printout of any measurement(s) desired. Because of the size of the plot routines and the memory buffers required to drive the printer-plotter, posttest mode must have exclusive use of the processor in which it is running.

## **APPENDIX G**

### **Spacelab Configuration: Functional and Operational Capabilities**

#### **NOTICE**

The material in this appendix is a reprint  
of a joint publication by ESA and NASA



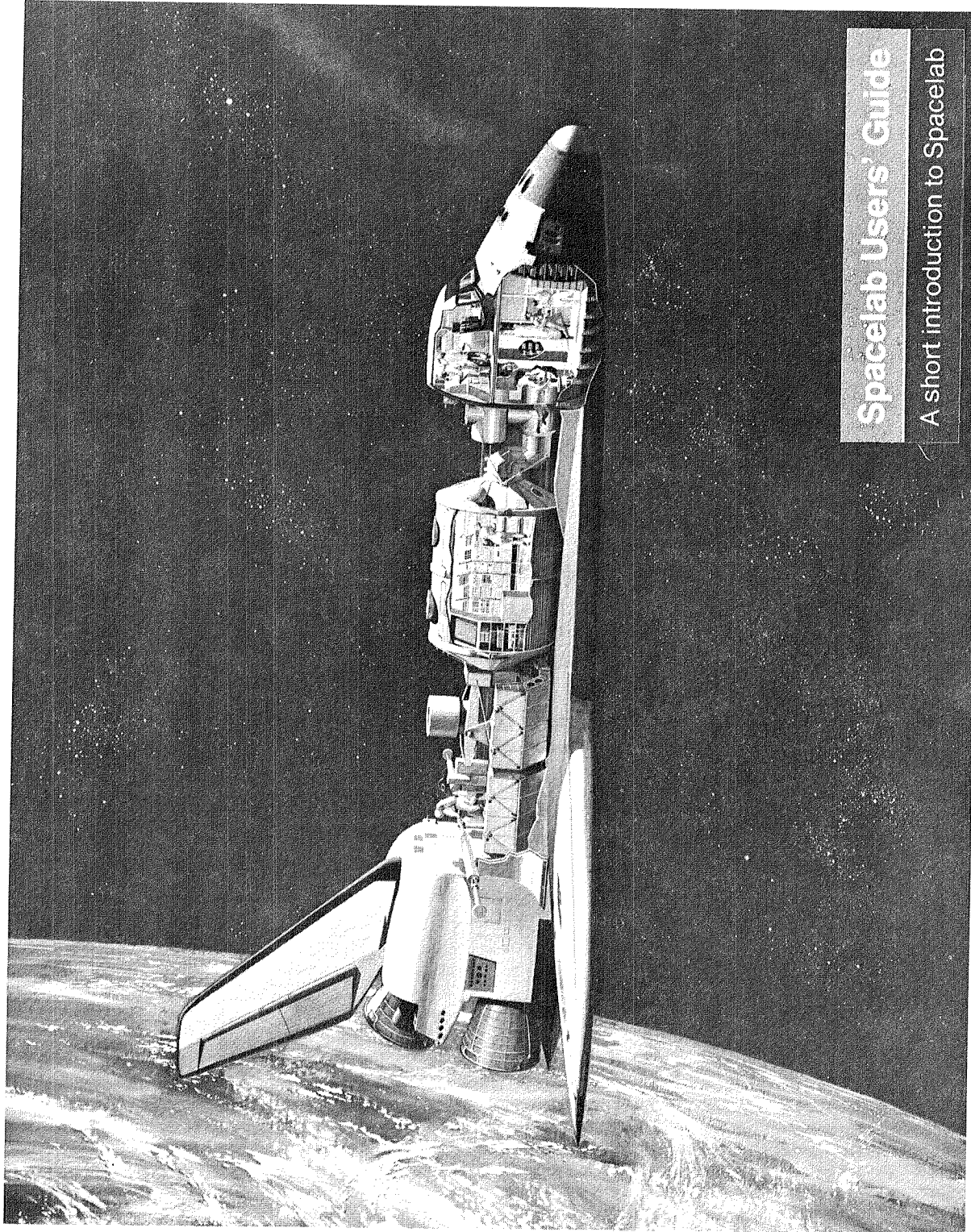

**Spacelab Users' Guide**

A short introduction to Spacelab

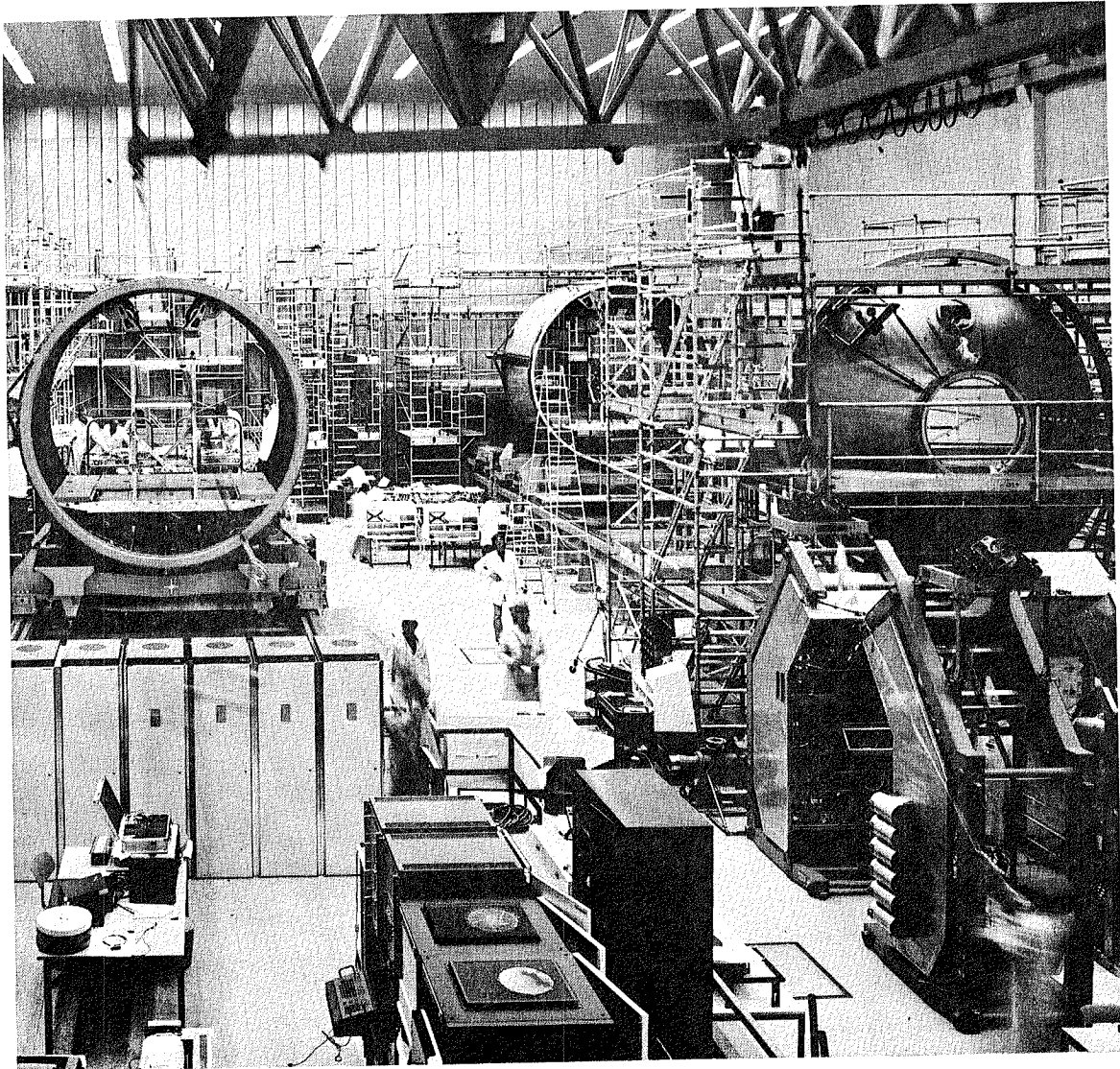

*Module shell elements, racks and subfloor  
of Engineering Model in Integration Hall,  
ERNO, Bremen.*

**esa SP-1001**

Issue no 2  
May 1979

## **Spacelab Users' Guide**

### A short introduction to Spacelab

#### **Contents**

Foreword  
Introduction  
Spacelab description  
Mission flexibility  
User services  
Spacelab utilisation  
Spacelab/payload operations  
Safety material control and reliability  
Schedule  
Experiment selection procedures  
User documentation

Published Jointly by:

**esa**

8-10, Rue Mario Nikis, 75738 Paris, France  
Tel.: 567 55 78. Telex: 202 746.

**NASA**

Washington, D.C. 20546, U.S.A.

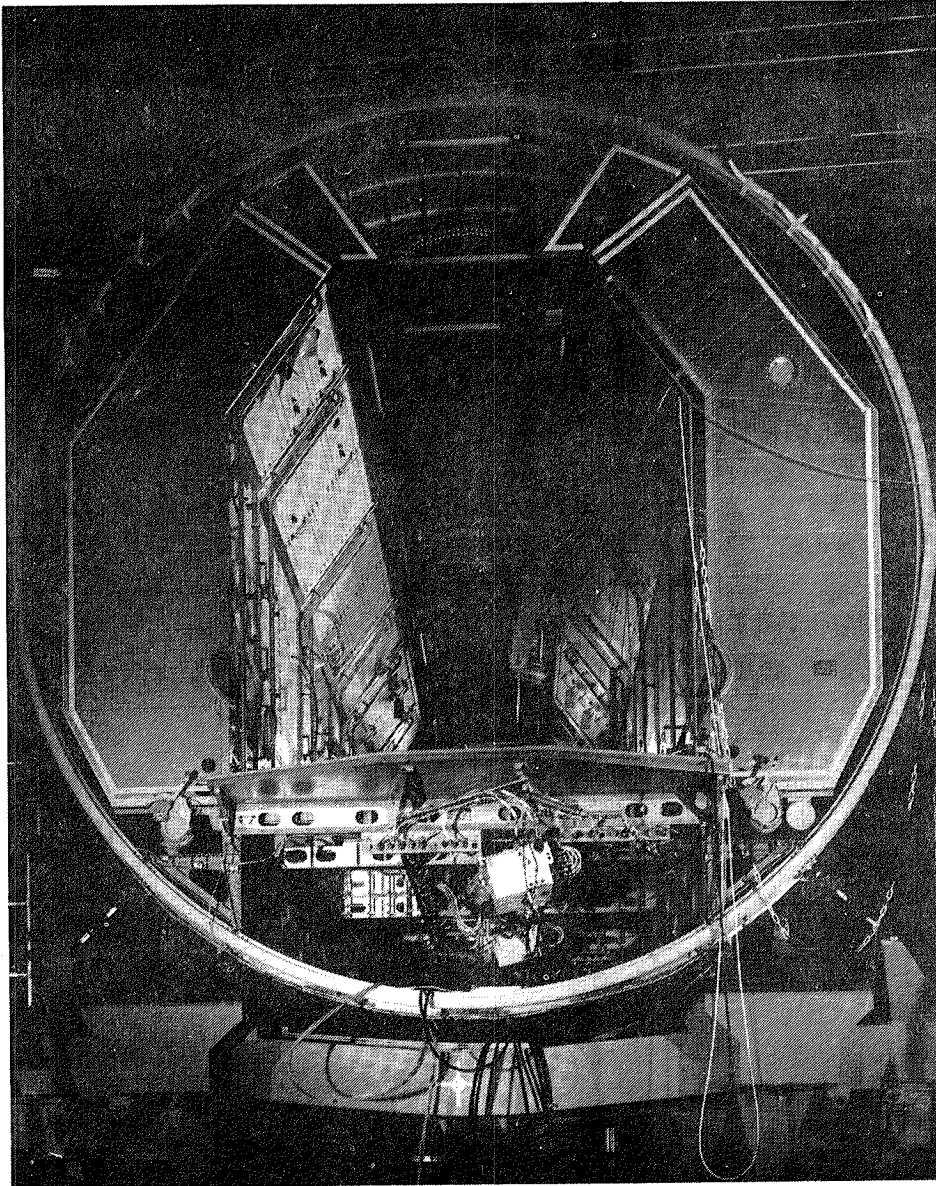

*Long module of Spacelab  
engineering model with integrated  
subsystems and experiment racks  
during testing.*

## Foreword

The purpose of this document is to introduce Spacelab to likely future users and to present its potential in the field of science, applications and technology. This orbital laboratory concept will be available throughout the 1980s. If you feel that you can use the facilities offered by Spacelab you are invited to contact

### In Europe

European Space Agency  
8-10 rue Mario Nikis  
75738 Paris 15  
France

### In the USA

National Aeronautics and  
Space Administration  
Washington DC 20546  
USA

### Approvals

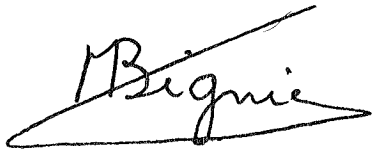

Michel Bignier  
Director of Spacelab Programme  
European Space Agency



Douglas R Lord  
Director, Spacelab Program  
National Aeronautics and  
Space Administration



## Introduction

Spacelab is an orbital facility that provides a pressurised, 'shirt-sleeve' laboratory (the module) and an unpressurised platform (the pallet), together with certain standard services. It is a reusable system. As part of the Space Transportation System (STS) it is transported to and from orbit in the cargo bay of the Space Shuttle Orbiter and remains there throughout the flight. Spacelab extends the Shuttle capability, and the Orbiter/Spacelab combination can be regarded as a short-stay space station which can remain in orbit initially for up to 12 days and eventually up to 30 days (the nominal mission duration is seven days). In orbit the experiments carried by Spacelab are operated by a team of up to four payload specialists who work in the laboratory but spend their off-duty time in the Orbiter cabin.

The purpose of Spacelab is to provide ready access to space for a broad spectrum of experimenters in many fields and from many nations. Low-cost techniques are envisaged for experiment development, integration and operation. The aim of this document is to provide a brief summary of Spacelab design characteristics and its potential for experimenters wishing to take advantage of the unique opportunities offered for space experimentation.

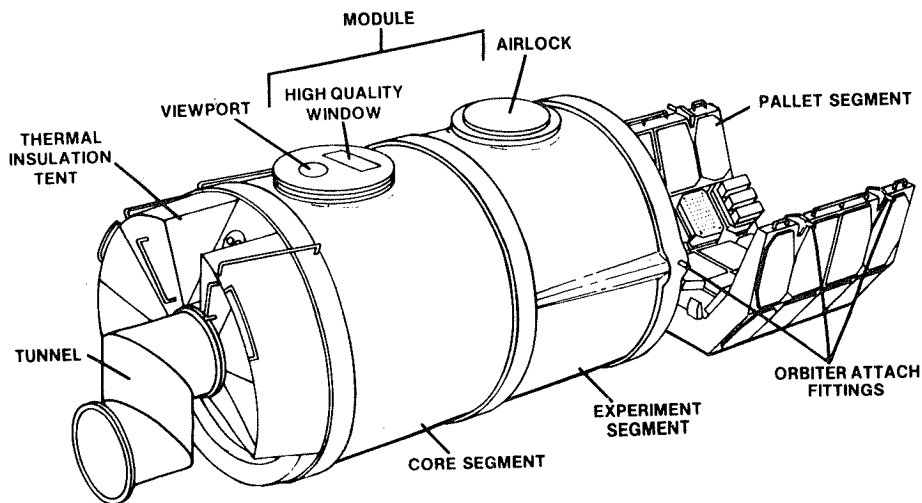

*Figure 1: Spacelab external design features*



## Spacelab description

The principal design features of Spacelab are shown in Figures 1 and 2. The module may be composed of one or two identical cylindrical shells (2.7 m long, 4.1 m in diameter) enclosed by two end cones. The pallet is composed of up to five segments, each 2.9 m long, of unpressurised structure. The module and pallet elements are firmly attached to the Orbiter.

The core segment contains the basic Spacelab subsystems but also has volume set aside for experiments. The experiment segment provides additional experiment space. The subsystems and experiment equipment are housed in standard 19 inch racks attached to the floor so that they can be removed during ground operations along with the associated floor elements. Equipment in the racks can be designed to be withdrawn during the orbital flight for ready access.

The pallet segments may be attached individually to the Orbiter or in continuous trains of up to three rigidly attached segments. When only pallets are to be flown, essential subsystems can be carried in an igloo which provides a pressurised and thermally controlled environment for them. Experiments

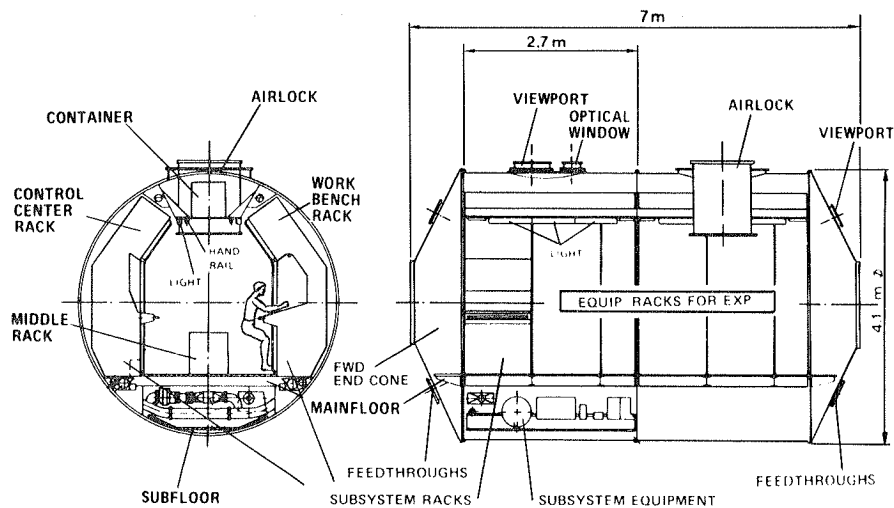
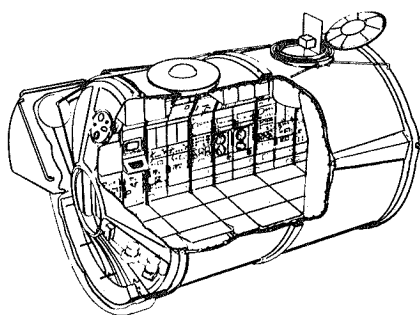

Figure 2. Sectional views of Spacelab module

mounted on the pallet can be controlled from the Spacelab module, the Orbiter cabin, or from the ground. Additionally, a manipulator arm controlled from the Orbiter for extra vehicular activity (EVA) by members of the Orbiter crew can be used for performing certain activities on experiments exposed directly to space.

For experiments requiring specific operating conditions, certain elements of the payload support equipment can be flown. These items are listed in Table 1 and some possible locations are indicated in Figures 1 and 2.



Spacelab module

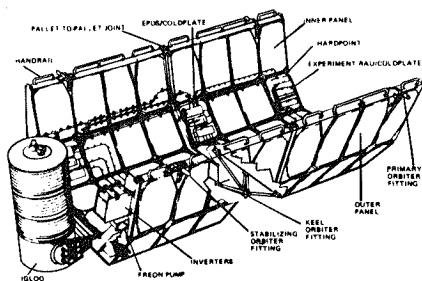

Spacelab pallet

Table 1 Payload support items

Airlock	One airlock (1 m diameter, 1 m long) available, to be used in top opening of experiment module; allows direct access to space from module. Supports up to 100 kg
High Quality Window	Skylab-type window permits observations from inside module for high-quality viewing in the visible and near-infrared parts of the spectrum; size 41 × 55 cm
Viewport	Two viewports (30 cm diameter) available, one in the aft end cone*, the other one in a top opening of the module
Experiment Vent Assembly*	Permits venting of gases from experiment chambers etc, located in the module
Feed-through*	Permits passage of lines (fluids, signals, etc) peculiar to experiments between module and pallet

\* always flown



Functional interfaces between the Orbiter, module and pallet are provided by suitable utility connections. Access to the module from the Orbiter cabin is by means of a tunnel. The latter is attached to the EVA adapter which in turn is linked to the Orbiter cabin itself. The variable length of the tunnel permits some freedom in placing the Spacelab elements in the cargo bay to provide better viewing conditions and/or to satisfy the centre-of-gravity constraints placed on Spacelab and its payload by the Orbiter.

A relatively mild environment is foreseen for Spacelab experiments. Some of the principal parameters are given in Table 2.

Table 2 Principal environment parameters

Parameter	Approximate values
Acceleration	Maximum 3 g linear acceleration during ascent and descent; typically $10^{-4}$ g on orbit
Vibration	145 dB acoustic noise in cargo bay (launch only); 136 dB acoustic noise inside module (launch only); typically 4 g RMS random vibration input to equipment in racks in the module
Thermal	<p>Inside the module: equipment cooling through forced air in the range 20 to 40°C, cabin air in the range 18 to 27°C (adjustable). One cold plate (10 to 40°C) and 4kW heat exchanger available</p> <p>On pallet: equipment cooling by cold plates with temperatures in the range 10 to 40°C</p>
Contamination	Arises from Orbiter, Spacelab and experiment equipment. Precautions will be taken in design to reduce level as far as practically possible. Dumps can be programmed

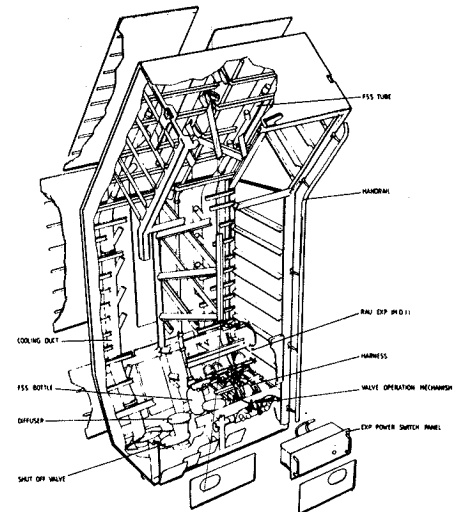

Essential elements of experiment double rack

## Mission flexibility

The Spacelab concept possesses considerable flexibility in its application to a variety of missions. This very important characteristic arises from two sources.

Firstly, the Space Shuttle flight parameters may be varied so that the orbit inclination, orbit altitude (200 to 900 km) and resulting ground coverage may be selected for mission compatibility. During the first few years of Shuttle operation, the East Coast launch site at Kennedy Space Center will be used so that the possible range of inclinations is 28.5 to 57°. Later, the West Coast site at Vandenberg will become available, thereby ensuring orbit inclinations up to 104°. Also the Orbiter orientation (all directions with an accuracy up to 0.5° per axis) and flight duration (initially up to 12, eventually up to 30 days) can be adjusted as required.

In the second place, Spacelab mission flexibility results from the modular approach adopted in the design. The module and pallet can be varied in size by selecting from the available Spacelab elements illustrated in Figure 3 in such a way that the resulting configuration fits the needs of the mission in question. Three basic configurations are apparent – module only, module plus pallet, pallet only. Further flexibility is introduced by the payload support equipment available. The subsystem elements are also modularised so that certain components (eg, cold plates, equipment racks, recorder) may be used or removed as required. This feature means that on a particular Spacelab flight, only those mission-dependent elements required by the experimenter are flown, permitting additional payload weight to be substituted for unnecessary equipment.

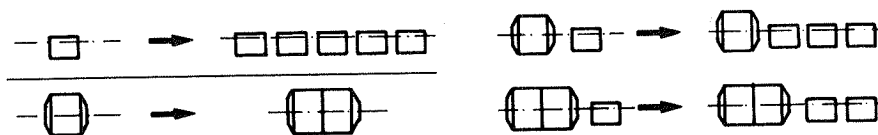

Figure 3: Spacelab configurations

## User services

The Orbiter/Spacelab subsystems provide basic services for running Spacelab itself and for the payload. These services are available to the experiments via standard interfaces and have been designed to ensure that near-laboratory-type equipment may be used in the module. The actual resources available to the payload are a function of the configuration being flown. Table 3 summarises the services provided in the case of four typical Spacelab configurations. It is the task of the mission planner to ensure that the sums of the requirements of all experiments in the payload do not exceed the total resources available. The services provided include the use of an instrument pointing subsystem (Figure 4).

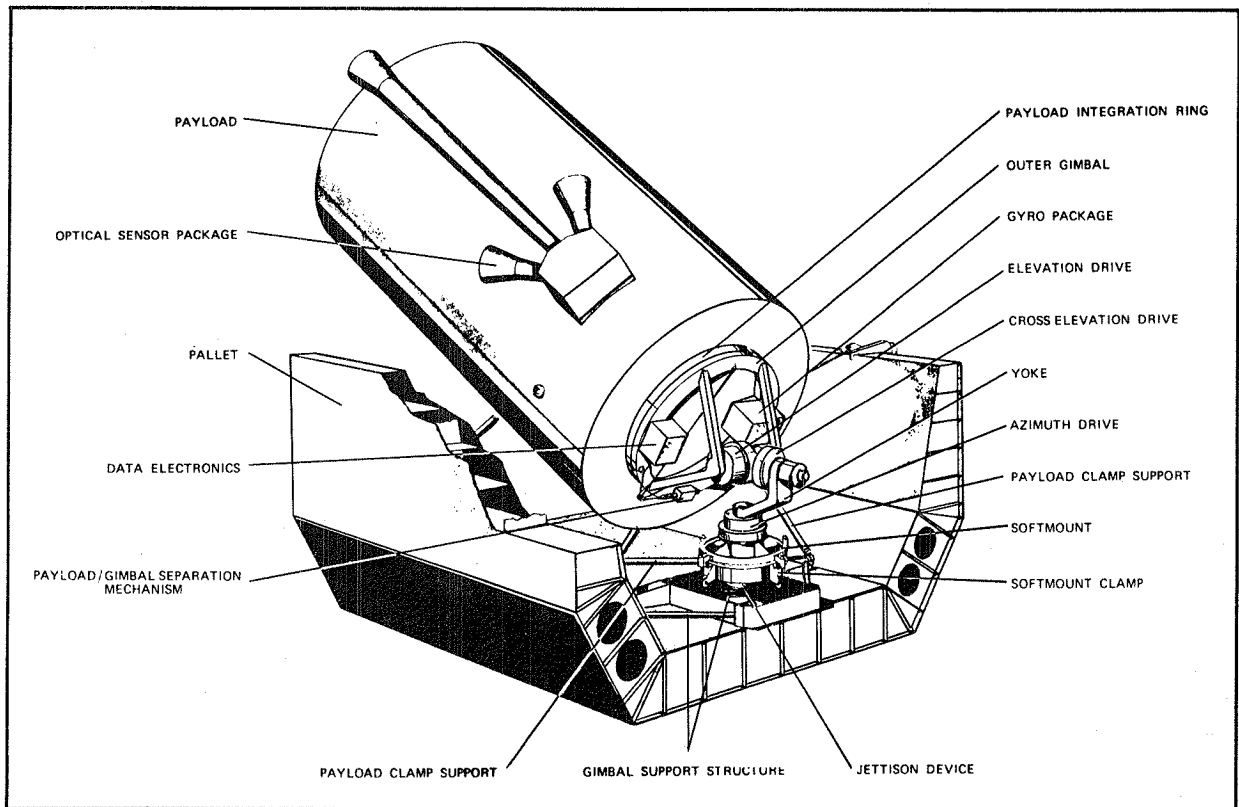

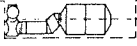

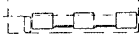

Figure 4: Instrument pointing subsystem

Table 3 Spacelab services for users

Spacelab configuration				
	Short module +9 m pallet	Long module	15 m pallet	Independently suspended pallet
Payload weight (kg) <sup>1</sup>	5000 - 6000	4800 - 6200	7700 - 8300	8800 - 9400
Volume for experiment equipment:				
Inside module (m <sup>3</sup> )	8	22	—	—
On pallet (m <sup>3</sup> )	100	—	160	100
Pallet mounting area (m <sup>2</sup> )	51	—	85	51
Electrical power (28 V DC 115/200 V at 400 Hz AC) <sup>2</sup> :				
Average (kW) <sup>1</sup>	2.5 - 4.0	2.5 - 4.5	4.5 - 5.5	4.5 - 5.5
Peak (kW) <sup>1</sup>	8	8	9	9
Energy (kWh) <sup>3</sup>	~ 250	~ 300	~ 550	~ 550
Experiment-support computer with central processing unit and data acquisition system	64 K core memory of 16 bit words, 350 000 operations per second, 15 K core available to users			
Data handling:				
Transmission through Orbiter	Up to 50 Mbps	Up to 50 Mbps	Up to 50 Mbps	Up to 50 Mbps
Storage digital data	Up to 30 Mbps	Up to 30 Mbps	Up to 1 Mbps	Up to 1 Mbps
	total of	total of	total of	total of
	3 × 10 <sup>10</sup> bits	3 × 10 <sup>10</sup> bits	3 × 10 <sup>9</sup> bits <sup>4</sup>	3 × 10 <sup>9</sup> bits <sup>4</sup>
Instrument pointing subsystem IPS	Mounted on pallet, will provide arc second pointing for payloads up to 3000 kg			

1 Depends on the amount of mission-dependent equipment flown

2 Depends on the power and energy consumed by mission-dependent equipment and the degree of usage by switchable subsystem equipment

3 Energy can be increased by the addition of payload-chargeable kits, each providing 840 kWh and weighing approximately 350 kg (at landing)

4 Using Orbiter Payload Recorder.

## Spacelab utilisation

Spacelab users will be drawn from the various disciplines of science, applications and technology. Investigations have shown that, at least, the following fields are likely to obtain benefits from the utilisation of Spacelab:

- high-energy astrophysics
- ultraviolet, optical, infrared and X-ray stellar, planetary and solar astronomy
- atmospheric, ionospheric (plasma) and magnetospheric physics
- life sciences (including biology, biomedicine, behaviour)
- remote earth-sensing (meteorology, land-use planning, resources, pollution control, etc)
- material sciences (eg, crystal growth, pure metals and alloys, composite materials) and fluid physics
- processing and manufacturing in space (eg, electrophoresis, high-strength materials)
- communications and navigation
- advanced technology in all disciplines.

These fields are cited as typical and additional areas that could benefit from using Spacelab will be identified as the programme matures. It is foreseen that Spacelab will play an important role in the various development phases of those disciplines, which include pure research, instrument R&D, experimental processes and the execution of operational programmes.

Spacelab provides a capability for two modes of experimentation – man-tended activities or automated observations. The choice of mode is left to the experimenters who may prefer to have an operator in attendance who can improve the overall efficiency of the planned experimentation and fully exploit unexpected events. On the other hand, automated operation of the equipment may be preferable.

In addition to the basic services provided by Spacelab, certain experiment facilities (eg, furnaces, telescopes, high-power lasers) will be available for

certain missions. These 'facilities' are not provided as part of the Spacelab Programme, but will be supplied from 'user' sources, and experimenters from a wide variety of disciplines may take advantage of them for exploring their particular problem areas. In this way it will be possible to attract users of Spacelab from all levels of the scientific and technical communities, be it small university groups or large government agencies. Thus, the participation of an experimenter in Spacelab activities may take four basic forms:

- by provision of a complete experiment unit, ie, facility plus detectors or samples;
- by supplying experiments for use with a common facility, eg, 'behind the focus' type experimentation;
- by provision of an independent experiment which does not utilise a facility; and
- by use of the data generated during a Spacelab mission without the provision of any equipment itself as in the case of certain earth-observation data.

In planning experiments that require attendance, it must be stressed that payload specialists who fly in Spacelab will be scientists and technicians rather than professional astronauts, and no rigorous, long-duration, pre-flight training is envisaged.

In some cases it may be desirable to involve the user community on the ground. This involvement can be achieved by communicating experiment data to the ground, in realtime, via the Tracking and Data Relay Satellite System. Conversely, commands may be transmitted from the ground to Spacelab.

Studies carried out by ESA and NASA have shown that realistic payloads can be planned for accommodation in Spacelab. Depending on the mission objectives, various configurations result. Typical results for six disciplines are illustrated in Figure 5.

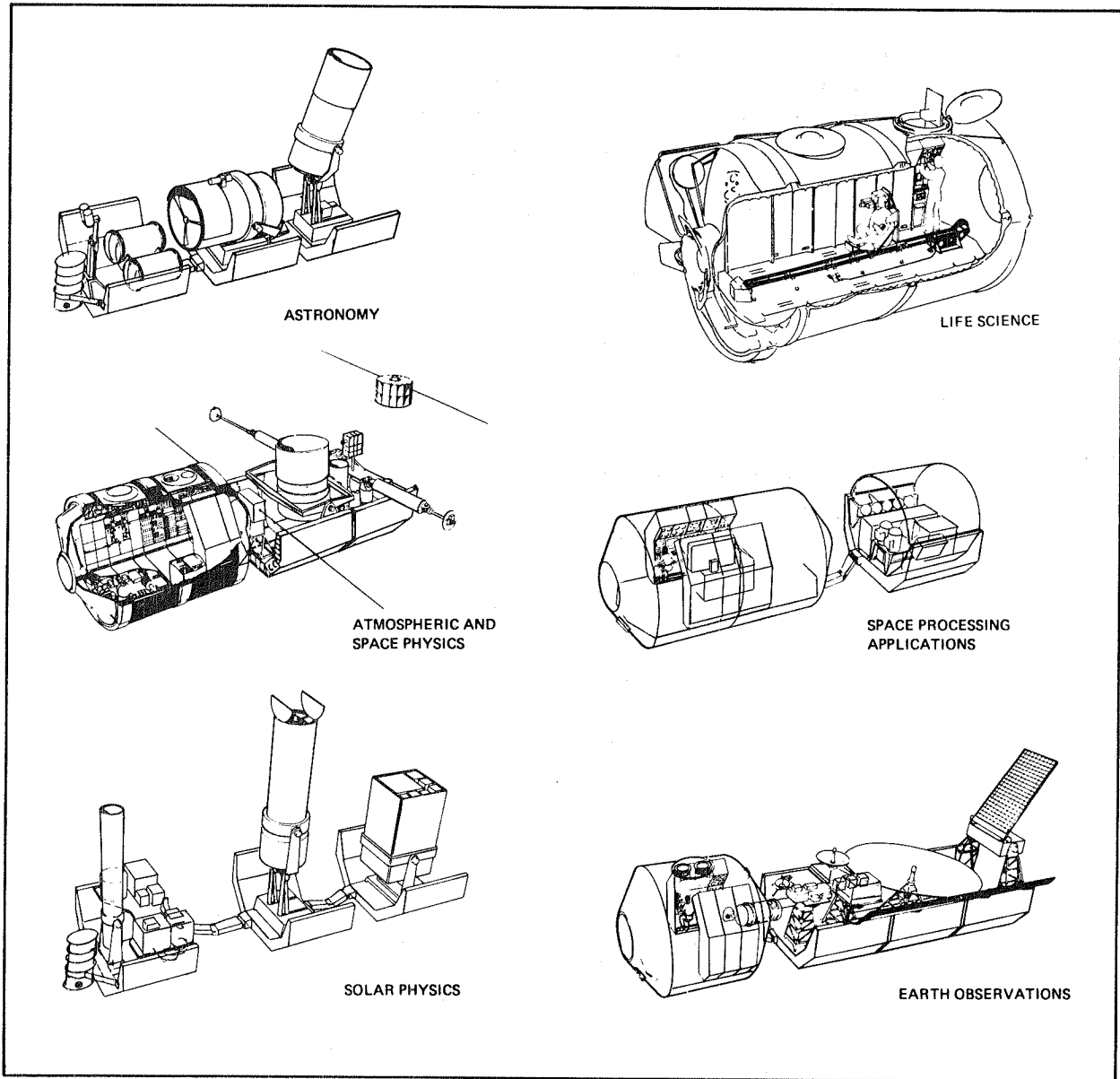

Figure 5: Spacelab configurations for various payloads

## Spacelab/payload operations

The schematic profile of Figure 6 represents the operational cycle of the Shuttle, Spacelab and its payload. The activities are repeated from flight to flight but with a different payload complement. The overall responsibility for these operations rests with NASA. Spacelabs and their payloads may be decoupled from the Shuttle turn-around cycle, thereby permitting more time for off-line payload preparation and integration.

It is intended that the experimenter be given an active role both on the ground and during the flight itself. The various phases envisaged for experiment integration are described as follows:

- Level IV: integration and checkout of experiment equipment with individual experiment mounting elements (eg, racks and pallet segments) – activities that will be possible at the user's home facility.
- Level III: combination, integration and checkout of all experiment mounting elements (eg, racks, rack sets and pallet segments) with experiment equipment already installed, and of experiment and Spacelab software, ie, payload integration normally carried out at Kennedy Space Center (KSC).
- Level II: integration and checkout of the combined experiment equipment and experiment mounting elements with the flight subsystem support elements (ie, core segment, igloo) and experiment segments when applicable – activities normally performed at KSC.
- Level I: integration and checkout of the Spacelab and its payload with the Shuttle Orbiter, including the necessary pre-installation testing with simulated interfaces – this procedure is carried out at the actual launch site.

The Level II integration procedure for module-located experiments is facilitated by the roll-out design concept adopted for Spacelab. The payload is contained in the rack and floor combination, which is literally rolled into the Spacelab shell by a roller-rail system.

Special organisations have been set up in Europe and the USA to ensure that the relevant integration phases are effectively executed. These organisations



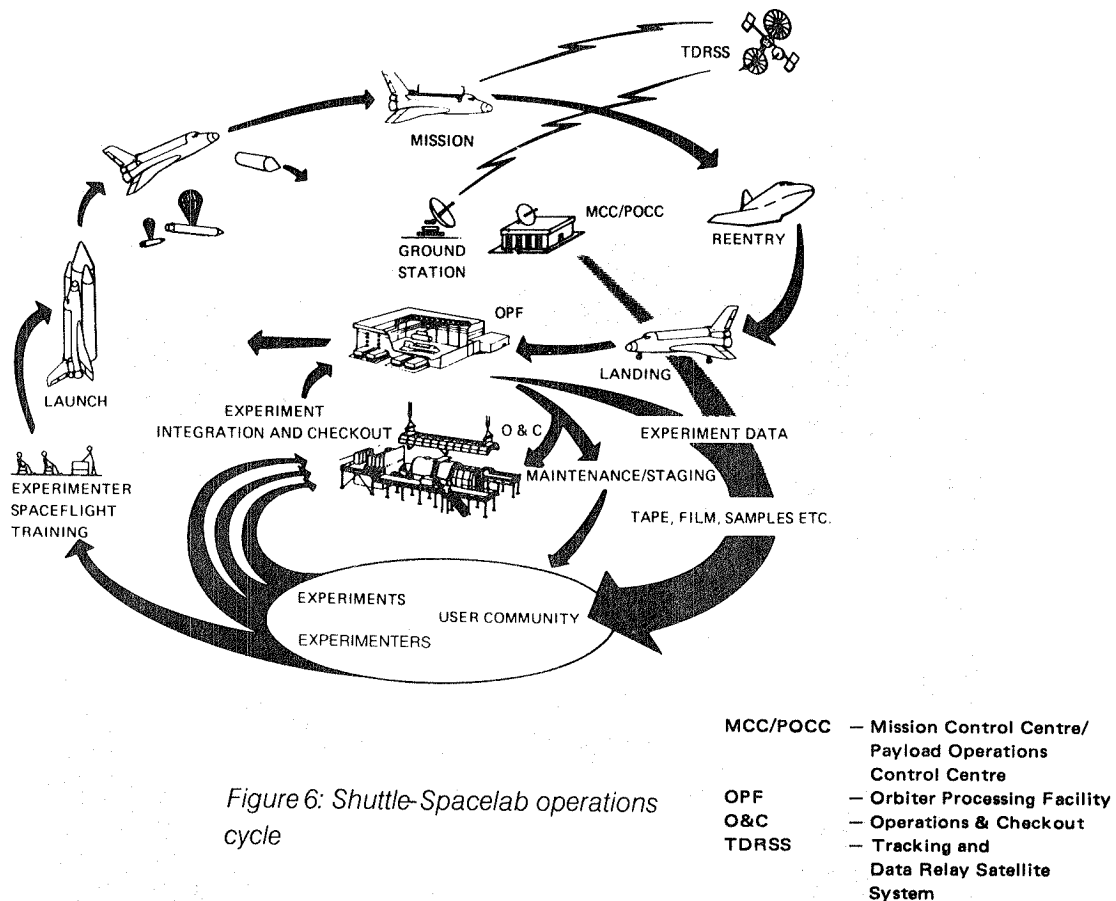
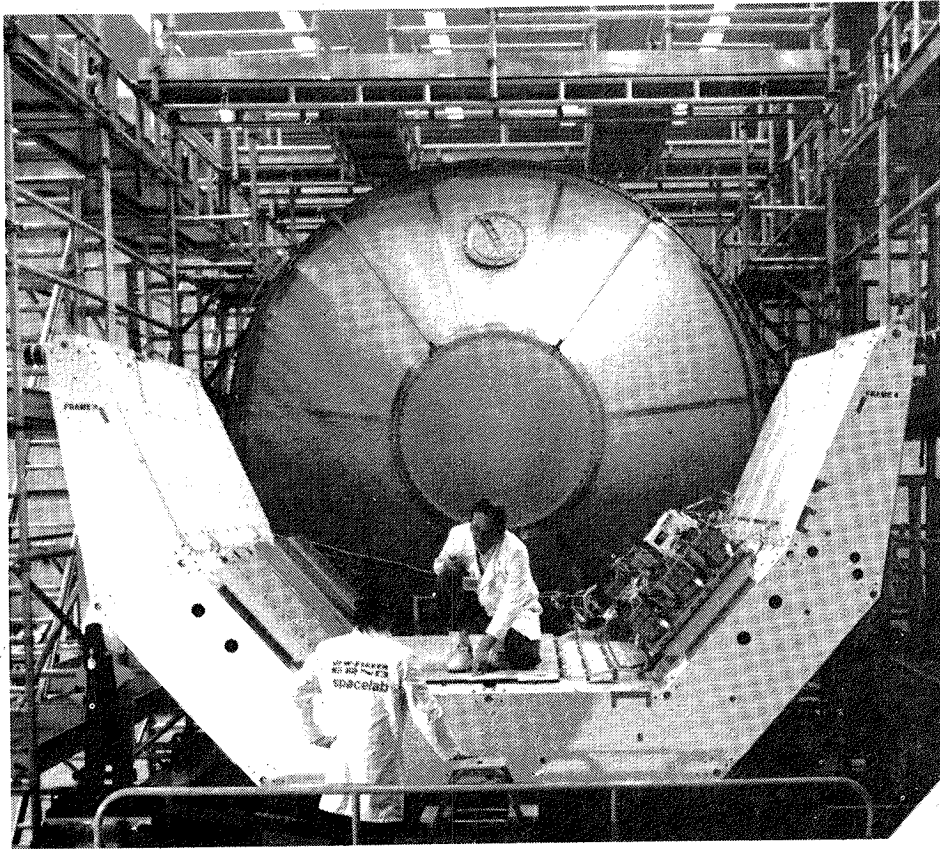

Figure 6: Shuttle-Spacelab operations cycle

also ensure that adequate support is given (including the necessary ground support equipment) to the experimenter during the equipment development phase.

During the flight, an Earth-bound experimenter can interface directly with on-board equipment, but this must be done via the Payload Operations Control Center in Houston, Texas. Stored data, specimens, and other results will be distributed to the experimenter as soon as possible after the Orbiter landing. The payload specialist for a particular mission could be selected and trained by the sponsoring user organisation, and may be drawn from the scientific and technical community having a specific interest in that mission. A training period of about one to two years is currently foreseen, and it will involve payload and Shuttle-environment familiarisation. Although the payload training may be



*Figure 7: Integrated Spacelab module and pallet (Engineering Model).*

carried out at a number of locations, the Shuttle-environment (flight) familiarisation will be conducted by NASA.

It is stressed that flying experiments on board Spacelab is envisaged as a low-cost activity. This philosophy applies equally to experiment development, payload integration, and flight transportation. In general, a minimum of documentation and compliance requirements will apply although basic safety constraints must be met. Transportation costs will be charged on a pro rata basis according to the demands placed on weight and volume.

## **Safety material control and reliability**

To keep the cost of experiments as low as possible the design requirements imposed on the user's equipment will be reduced in comparison with earlier manned space programme levels. Design aspects which affect only the reliability of an experiment and which ensure that it will meet its scientific and functional objectives will not be controlled by formal Shuttle/Spacelab constraints but will be left to the discretion of the user. Those design aspects, however, which ensure physical and functional compatibility between the experiment and the Shuttle/Spacelab and which minimise the risk of damage and/or hazardous conditions which could affect the safety of personnel or equipment will be subject to some formal constraints.

Constraints on experiment-produced noise and electromagnetic interference, for example, will be necessary to protect the crew and subsystems respectively, from hazardous levels. Also, certain payload structural elements may need to be designed to meet Orbiter loads.

Some material selection and control constraints will be necessary to protect the crew from fire and from contamination of the Orbiter or module atmosphere. For example, equipment mounted in the Orbiter, which is regarded as a safe haven for the crew in the event of hazardous conditions in the module, will be subject to strict material control. Equipment mounted in the module may incorporate 'off-the-shelf' hardware which can be subjected to an off-gassing screening test at black-box or higher level.

The Shuttle/Spacelab system itself will have basic safety provisions such as fire detection and suppression systems, face masks, etc. Additional safety features include the provision of abort and rescue capabilities.

## Schedule

The first flight of Spacelab is foreseen for late 1981. Subsequently, a mission model for Spacelab flight will be followed which reflects the user needs and the available funding. Existing models should not be regarded as a commitment, but will be used for planning and checking the associated ground-support equipment, software and procedures. Tentative estimates of Spacelab flight opportunities indicate that, starting at about five per year in the early 1980s, the launch rate may build up to about 20 per year in the mid-1980s. Higher rates can be achieved should the need arise. At present flights dedicated to both single and multi-disciplines are envisaged.

A fully functional engineering model will be available in the US from early-1980. This model will be used for the development of maintenance and refurbishment procedures and also for experiment integration verification, crew training and some mission simulation.

Experiment development times will depend on the type and complexity of the equipment involved, but, generally, experiment gestation times of months are foreseen (rather than the years normally associated with automated satellites). It is estimated that the time for the payload integration phases III through to I will not exceed about six months for the initial missions and about 30 days for later ones.

## Experiment selection procedures

Because of the nature of Spacelab missions, the procedure for the selection of experiments to achieve the mission objectives will vary from flight to flight. Hence, no hard and fast rules can be laid down. The use of Spacelab will be programmed by NASA and ESA, and planning projections (utilisation models) will be issued from time to time. Normally both agencies will select experiments from within their respective programmes and from proposals generated by the user community in answer to an Announcement of Opportunity (AO) based on the utilisation model.

Due to the different funding mechanisms, ESA and NASA procedures are not necessarily the same. Generally speaking, ESA assures flight if the experiments are technically acceptable and their funding from a national source is secured. In some cases, NASA provides funding for its chosen experiments. Once accepted for flight the experimenter becomes involved in its planning and implementation. Experiment proposals will always be considered on an unsolicited basis.

More details relating to how an experimenter may get on board Spacelab can be obtained by contacting ESA or NASA (addresses in Foreword).

## User documentation

A minimum of documentation is envisaged for the control of user equipment destined for use on Spacelab. Details of the interfaces to be satisfied between the experiment equipment and Spacelab may be found in the *Spacelab Payload Accommodation Handbook*, ESA SLP 2104. This document also contains a detailed description of the Spacelab system and subsystems, together with information on the environmental and operational requirements. This document is available from either ESA or NASA (see the Foreword for addresses).

For every Spacelab mission additional mission-specific documentation will be required. The basic documents are the Experiment Requirements Document (ERD), a document specifying actual experiment interfaces, eg, the Instrument Interface Agreement (IIA) used in the first Spacelab flight) and the Payload Integration Plan (PIP). The ERD is prepared by the experimenter and specifies the experiment support requirements, while the IIA-type document and the PIP are prepared by ESA/NASA. These latter documents represent agreement between the experimenter and ESA/NASA on experiment interfaces and between the payload and STS concerning integration responsibilities and related tasks respectively.

Additional information on the Space Shuttle Orbiter, Spacelab and other elements in the Space Transportation System is contained in the *Space Transportation System User Handbook* available from NASA or ESA.

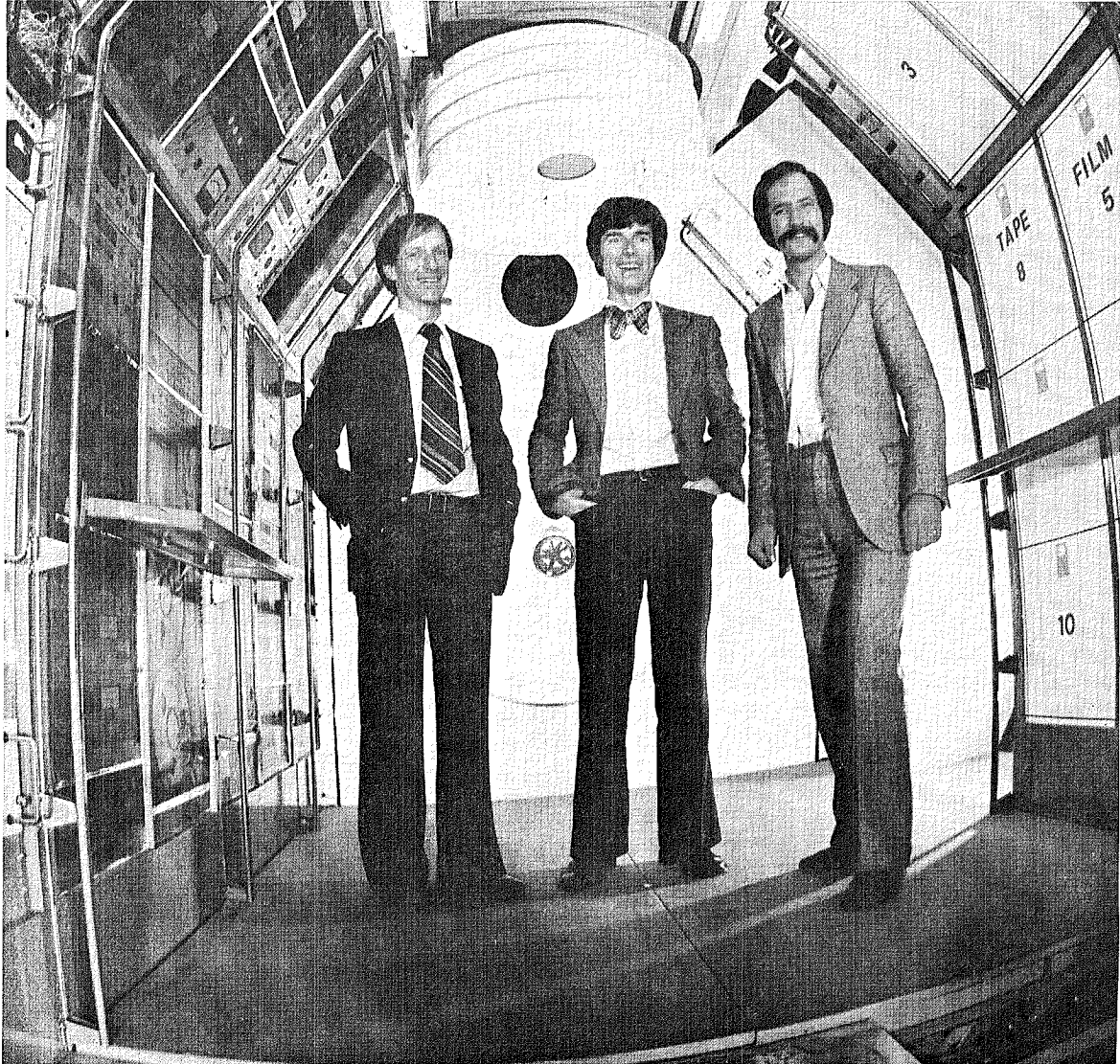

*European Payload Specialists in full size Spacelab model.*





**End of Document**